

## Planning and Preliminary Engineering Applications Guide to the Highway Capacity Manual

### DETAILS

---

259 pages | 8.5 x 11 | PAPERBACK

ISBN 978-0-309-37565-8 | DOI 10.17226/23632

### AUTHORS

---

Richard Dowling, Paul Ryus, Bastian Schroeder, Michael Kyte, Thomas Creasey, Nagui Roupail, Ali Hajbabaie, and Danica Rhoades; National Cooperative Highway Research Program; Transportation Research Board; National Academies of Sciences, Engineering, and Medicine

BUY THIS BOOK

FIND RELATED TITLES

### Visit the National Academies Press at [NAP.edu](http://NAP.edu) and login or register to get:

---

- Access to free PDF downloads of thousands of scientific reports
- 10% off the price of print titles
- Email or social media notifications of new titles related to your interests
- Special offers and discounts



Distribution, posting, or copying of this PDF is strictly prohibited without written permission of the National Academies Press. (Request Permission) Unless otherwise indicated, all materials in this PDF are copyrighted by the National Academy of Sciences.

NATIONAL COOPERATIVE HIGHWAY RESEARCH PROGRAM

---

---

**NCHRP REPORT 825**

---

---

**Planning and Preliminary  
Engineering Applications Guide  
to the Highway Capacity Manual**

**Richard Dowling**

**Paul Ryus**

**Bastian Schroeder**

**KITTELSON & ASSOCIATES, INC.**

Portland, Oregon

**Michael Kyte**

**UNIVERSITY OF IDAHO**

Moscow, Idaho

**F. Thomas Creasey**

**STANTEC**

Lexington, Kentucky

**Nagui Roupail**

**Ali Hajbabaie**

**ITRE AT N.C. STATE UNIVERSITY**

Raleigh, North Carolina

**Danica Rhoades**

**WRITE RHETORIC**

Boise, Idaho

*Subscriber Categories*

Planning and Forecasting

---

Research sponsored by the American Association of State Highway and Transportation Officials  
in cooperation with the Federal Highway Administration

---

**TRANSPORTATION RESEARCH BOARD**

WASHINGTON, D.C.

2016

[www.TRB.org](http://www.TRB.org)

## NATIONAL COOPERATIVE HIGHWAY RESEARCH PROGRAM

Systematic, well-designed research is the most effective way to solve many problems facing highway administrators and engineers. Often, highway problems are of local interest and can best be studied by highway departments individually or in cooperation with their state universities and others. However, the accelerating growth of highway transportation results in increasingly complex problems of wide interest to highway authorities. These problems are best studied through a coordinated program of cooperative research.

Recognizing this need, the leadership of the American Association of State Highway and Transportation Officials (AASHTO) in 1962 initiated an objective national highway research program using modern scientific techniques—the National Cooperative Highway Research Program (NCHRP). NCHRP is supported on a continuing basis by funds from participating member states of AASHTO and receives the full cooperation and support of the Federal Highway Administration, United States Department of Transportation.

The Transportation Research Board (TRB) of the National Academies of Sciences, Engineering, and Medicine was requested by AASHTO to administer the research program because of TRB's recognized objectivity and understanding of modern research practices. TRB is uniquely suited for this purpose for many reasons: TRB maintains an extensive committee structure from which authorities on any highway transportation subject may be drawn; TRB possesses avenues of communications and cooperation with federal, state, and local governmental agencies, universities, and industry; TRB's relationship to the Academies is an insurance of objectivity; and TRB maintains a full-time staff of specialists in highway transportation matters to bring the findings of research directly to those in a position to use them.

The program is developed on the basis of research needs identified by chief administrators and other staff of the highway and transportation departments and by committees of AASHTO. Topics of the highest merit are selected by the AASHTO Standing Committee on Research (SCOR), and each year SCOR's recommendations are proposed to the AASHTO Board of Directors and the Academies. Research projects to address these topics are defined by NCHRP, and qualified research agencies are selected from submitted proposals. Administration and surveillance of research contracts are the responsibilities of the Academies and TRB.

The needs for highway research are many, and NCHRP can make significant contributions to solving highway transportation problems of mutual concern to many responsible groups. The program, however, is intended to complement, rather than to substitute for or duplicate, other highway research programs.

## NCHRP REPORT 825

Project 07-22

ISSN 0077-5614

ISBN 978-0-309-37565-8

Library of Congress Control Number 2016950446

© 2016 National Academy of Sciences. All rights reserved.

### COPYRIGHT INFORMATION

Authors herein are responsible for the authenticity of their materials and for obtaining written permissions from publishers or persons who own the copyright to any previously published or copyrighted material used herein.

Cooperative Research Programs (CRP) grants permission to reproduce material in this publication for classroom and not-for-profit purposes. Permission is given with the understanding that none of the material will be used to imply TRB, AASHTO, FAA, FHWA, FMCSA, FRA, FTA, Office of the Assistant Secretary for Research and Technology, PHMSA, or TDC endorsement of a particular product, method, or practice. It is expected that those reproducing the material in this document for educational and not-for-profit uses will give appropriate acknowledgment of the source of any reprinted or reproduced material. For other uses of the material, request permission from CRP.

### NOTICE

The report was reviewed by the technical panel and accepted for publication according to procedures established and overseen by the Transportation Research Board and approved by the National Academies of Sciences, Engineering, and Medicine.

The opinions and conclusions expressed or implied in this report are those of the researchers who performed the research and are not necessarily those of the Transportation Research Board; the National Academies of Sciences, Engineering, and Medicine; or the program sponsors.

The Transportation Research Board; the National Academies of Sciences, Engineering, and Medicine; and the sponsors of the National Cooperative Highway Research Program do not endorse products or manufacturers. Trade or manufacturers' names appear herein solely because they are considered essential to the object of the report.

*Published reports of the*

### NATIONAL COOPERATIVE HIGHWAY RESEARCH PROGRAM

*are available from*

Transportation Research Board  
Business Office  
500 Fifth Street, NW  
Washington, DC 20001

*and can be ordered through the Internet by going to*

<http://www.national-academies.org>

*and then searching for TRB*

Printed in the United States of America

## *The National Academies of* SCIENCES • ENGINEERING • MEDICINE

The **National Academy of Sciences** was established in 1863 by an Act of Congress, signed by President Lincoln, as a private, non-governmental institution to advise the nation on issues related to science and technology. Members are elected by their peers for outstanding contributions to research. Dr. Marcia McNutt is president.

The **National Academy of Engineering** was established in 1964 under the charter of the National Academy of Sciences to bring the practices of engineering to advising the nation. Members are elected by their peers for extraordinary contributions to engineering. Dr. C. D. Mote, Jr., is president.

The **National Academy of Medicine** (formerly the Institute of Medicine) was established in 1970 under the charter of the National Academy of Sciences to advise the nation on medical and health issues. Members are elected by their peers for distinguished contributions to medicine and health. Dr. Victor J. Dzau is president.

The three Academies work together as the **National Academies of Sciences, Engineering, and Medicine** to provide independent, objective analysis and advice to the nation and conduct other activities to solve complex problems and inform public policy decisions. The Academies also encourage education and research, recognize outstanding contributions to knowledge, and increase public understanding in matters of science, engineering, and medicine.

Learn more about the National Academies of Sciences, Engineering, and Medicine at [www.national-academies.org](http://www.national-academies.org).

---

The **Transportation Research Board** is one of seven major programs of the National Academies of Sciences, Engineering, and Medicine. The mission of the Transportation Research Board is to increase the benefits that transportation contributes to society by providing leadership in transportation innovation and progress through research and information exchange, conducted within a setting that is objective, interdisciplinary, and multimodal. The Board's varied committees, task forces, and panels annually engage about 7,000 engineers, scientists, and other transportation researchers and practitioners from the public and private sectors and academia, all of whom contribute their expertise in the public interest. The program is supported by state transportation departments, federal agencies including the component administrations of the U.S. Department of Transportation, and other organizations and individuals interested in the development of transportation.

Learn more about the Transportation Research Board at [www.TRB.org](http://www.TRB.org).

# COOPERATIVE RESEARCH PROGRAMS

## **CRP STAFF FOR NCHRP REPORT 825**

**Christopher W. Jenks**, *Director, Cooperative Research Programs*

**Christopher Hedges**, *Manager, National Cooperative Highway Research Program*

**B. Ray Derr**, *Senior Program Officer*

**Charlotte Thomas**, *Senior Program Assistant*

**Eileen P. Delaney**, *Director of Publications*

**Maria Sabin Crawford**, *Editor*

## **NCHRP PROJECT 07-22 PANEL**

### **Field of Traffic—Area of Traffic Planning**

**Dirk B. Gross**, *Ohio DOT, Delaware, OH (Chair)*

**Douglas S. McLeod**, *Florida DOT, Tallahassee, FL*

**Robert W. Bryson**, *Milwaukee, WI*

**Brian G. Dunn**, *Oregon DOT, Salem, OR*

**Jessie X. Jones**, *Arkansas SHTD, Little Rock, AR*

**Subrat Mahapatra**, *Maryland State Highway Administration, Baltimore, MD*

**Erik O. Ruehr**, *VRPA Technologies, Inc., San Diego, CA*

**Tyrone Anthony Scorsone**, *Cambridge Systematics, Inc., Tallahassee, FL*

**F. Andrew Wolfe**, *SUNY IT, Utica, NY*

**Jeremy Raw**, *FHWA Liaison*

**Matthew Hardy**, *AASHTO Liaison*

**Richard A. Cunard**, *TRB Liaison*

  
FOREWORD

By **B. Ray Derr**

Staff Officer

Transportation Research Board

This guide will help planners apply the methodologies of the Highway Capacity Manual (HCM) 2016 Major Update to common planning and preliminary engineering analyses (including scenario planning and system performance monitoring). It shows how the HCM can interact with travel demand forecasting, mobile source emission, and simulation models and its application to multimodal analyses and oversaturated conditions. Three case studies (freeway master plan, arterial bus rapid transit analysis, and long-range transportation plan analysis) illustrate the techniques presented in the guide. In addition to providing a cost-effective and reliable approach to analysis, the guide provides a practical introduction to the detailed methodologies of the HCM.

---

*NCHRP Synthesis 427: Extent of Highway Capacity Manual Use in Planning* recommended the development of an applications guide to address the use of HCM procedures in planning and preliminary engineering applications such as corridor studies, roadway widening projects, and traffic impact analyses. Survey respondents for that synthesis study thought that an applications guide could increase the accuracy and reliability of planning study results. It would also enhance the value of the resources used in the development of the HCM by allowing its broader use.

Under NCHRP Project 07-22, Kittelson & Associates, Inc., analyzed each chapter of the HCM to identify material that could be profitably applied to planning and preliminary engineering analyses. They also conducted focus groups to build upon *NCHRP Synthesis 427* regarding the use of the HCM and other tools in planning and preliminary engineering applications. The research team then wrote the guide and refined it through workshops with public agencies.

When the NCHRP project began, the intent was to base the guide upon the 2010 HCM. NCHRP Project 03-115 was subsequently funded to provide a major update to the HCM, and this guide is based upon that update, released in 2016.



# CONTENTS

## PART 1 Overview

<b>3</b>	<b>A. Introduction</b>
3	1. Overview
3	2. Scope of the Guide
5	3. Target Audience
5	4. How to Use the Guide
6	5. The Hierarchy of Analysis Methods
<b>8</b>	<b>B. Medium-Level (Facility-Specific) Analyses</b>
8	1. Overview
8	2. Project Traffic and Environmental Impact Studies
10	3. Applications of Default Values
10	4. References
<b>11</b>	<b>C. High-Level Analyses</b>
11	1. Overview
11	2. Screening and Scoping Studies
12	3. Long- and Short-Range Areawide Transportation Planning
13	4. System Performance Monitoring
14	5. References
<b>15</b>	<b>D. Working with Traffic Demand Data</b>
15	1. Overview
15	2. Selecting an Analysis Hour
15	3. Converting Daily Volumes to Shorter Timeframes
18	4. Seasonal Adjustments to Traffic Volumes
18	5. Rounding Traffic Volumes
19	6. Differences Between Observed Volumes and Actual Demand
19	7. Constraining Demand for Upstream Bottleneck Metering
21	8. Generating Turning-Movement Volume Estimates from Link Volumes
28	9. References
<b>29</b>	<b>E. Predicting Intersection Traffic Control</b>
29	1. Overview
29	2. Manual on Uniform Traffic Control Devices
30	3. Graphical Method
32	4. References

<b>33</b>	<b>F. Default Values to Reduce Data Needs</b>
33	1. Overview
33	2. When to Consider Default Values
34	3. Sources of Default Values
34	4. Developing Local Default Values
35	5. References
<b>36</b>	<b>G. Service Volume Tables to Reduce Analysis Effort</b>
36	1. Overview
36	2. Description
36	3. When to Consider Service Volume Tables
37	4. Sources of Generalized Service Volume Tables
39	5. References

## **P A R T 2    Medium-Level Analysis Methods**

<b>43</b>	<b>H. Freeway Analyses</b>
43	1. Overview
43	2. Applications
44	3. Analysis Methods Overview
45	4. Scoping and Screening Method
47	5. Employing the HCM with Defaults
47	6. Simplified HCM Facility Method
56	7. Reliability
58	8. Adaptations for Advanced Freeway Management Practices
59	9. Multimodal Level of Service
59	10. Example
60	11. References
<b>61</b>	<b>I. Multilane Highways</b>
61	1. Overview
61	2. Applications
61	3. Analysis Methods Overview
62	4. Scoping and Screening Method
64	5. Section Analysis Using HCM with Defaults
65	6. Multilane Facility Analysis Method
68	7. Reliability
69	8. Multimodal LOS
69	9. Example
69	10. References
<b>70</b>	<b>J. Two-Lane Highways</b>
70	1. Overview
70	2. Applications
70	3. Analysis Methods Overview
71	4. Scoping and Screening
73	5. Section Analysis Using HCM with Defaults
75	6. Two-Lane Facility Analysis Method
79	7. Reliability
80	8. Multimodal LOS
80	9. Example
80	10. Reference



## **81 K. Urban Streets**

- 81 1. Overview
- 81 2. Applications
- 82 3. Analysis Methods Overview
- 83 4. Scoping and Screening
- 86 5. Employing the HCM Method with Defaults
- 86 6. Simplified HCM Segment Analysis Method
- 97 7. Reliability Analysis
- 97 8. Multimodal LOS
- 97 9. Example
- 98 10. References

## **99 L. Signalized Intersections**

- 99 1. Overview
- 99 2. Applications
- 99 3. Analysis Methods Overview
- 101 4. Simplified Method, Part 1: Volume-to-Capacity Ratio Calculation
- 108 5. Simplified Method, Part 2: Delay, LOS, and Queue Calculation
- 112 6. Worksheets
- 112 7. Reliability Analysis
- 114 8. Multimodal LOS
- 114 9. Example
- 114 10. Reference

## **115 M. STOP-controlled Intersections**

- 115 1. Overview
- 115 2. Applications
- 115 3. Analysis Methods Overview
- 116 4. Simplified HCM Method for All-Way STOP-controlled Intersections
- 118 5. Simplified HCM Method for Two-Way STOP-controlled Intersections
- 124 6. Level of Service Analysis (AWSC and TWSC)
- 125 7. Queuing Analysis (AWSC and TWSC)
- 125 8. Worksheets
- 127 9. Reliability Analysis
- 127 10. Multimodal LOS
- 127 11. Example
- 127 12. Reference

## **128 N. Roundabouts**

- 128 1. Overview
- 128 2. Applications
- 128 3. Analysis Methods Overview
- 128 4. Simplified HCM Method
- 134 5. Worksheets
- 134 6. Reliability Analysis
- 136 7. Multimodal LOS
- 136 8. Example
- 136 9. Reference

## **137 O. Pedestrians, Bicyclists, and Public Transit**

- 137 1. Overview
- 137 2. Freeways
- 138 3. Multilane and Two-Lane Highways

139	4. Urban Streets
158	5. Signalized Intersections
160	6. STOP-controlled Intersections
162	7. Roundabouts
162	8. Off-Street Pathways
165	9. References
<b>166</b>	<b>P. Truck Level of Service</b>
166	1. Overview
166	2. Truck Level of Service Index
168	3. Estimating Probability of On-Time Arrival from TTI
168	4. A Service-TTI Lookup Table for Truck LOS
170	5. References

## **P A R T 3 High-Level Analyses**

<b>173</b>	<b>Q. Corridor Quick Estimation Screenline Analysis</b>
173	1. Overview
173	2. Screening for Capacity and Multimodal LOS Hot Spots
174	3. Screening Alternatives for Capacity Impacts
<b>176</b>	<b>R. Areas and Systems</b>
176	1. Overview
176	2. Computational Tools
176	3. Data Needs
177	4. Estimation of Demand Model Inputs
183	5. Performance Measure Estimation
187	6. References
<b>188</b>	<b>S. Roadway System Monitoring</b>
188	1. Overview
188	2. Travel Time Datasets
188	3. Identification of Problem Spots Through the Travel Time Index
190	4. Identification of Multimodal Problem Spots
190	5. Diagnosis of Causes of Mobility Problems
191	6. References

## **P A R T 4 Case Studies**

<b>195</b>	<b>T. Case Study 1: Freeway Master Plan</b>
195	1. Overview
196	2. Example 1: Focusing the Study—Screening for Service Volume Problems
201	3. Example 2: Forecasting v/c Hot Spots
207	4. Example 3: Estimating Speed and Travel Time
210	5. Example 4: Predicting Unacceptable Motorized Vehicle LOS Hot Spots
211	6. Example 5: Estimating Queues
214	7. Example 6: Predicting Reliability Problems
217	8. Example 7: Comparison of Overcongested Alternatives
221	9. Reference

## **222 U. Case Study 2: Arterial BRT Analysis**

- 222 1. Overview
- 223 2. Example 1: Preliminary Screening with Service Volume Tables
- 225 3. Example 2: Computing Critical Intersection Volume-to-Capacity Ratios
- 230 4. Example 3: Calculation of Intersection v/c Ratio for Permitted Left Turns
- 234 5. Example 4: Estimating Auto and BRT Speeds
- 241 6. Example 5: Predicting Queue Hot Spots
- 242 7. Example 6: Pedestrian, Bicycle, and Transit LOS
- 251 8. References

## **252 V. Case Study 3: Long-Range Transportation Plan Analysis**

- 252 1. Overview
- 253 2. Example 1: Estimating Free-Flow Speeds and Capacities for Model Input
- 255 3. Example 2: HCM-based Volume–Delay Functions for Model Input
- 257 4. Example 3: Predicting Density, Queues, and Delay
- 258 5. Example 4: Predicting Reliability
- 259 6. Reference

---

Note: Photographs, figures, and tables in this report may have been converted from color to grayscale for printing. The electronic version of the report (posted on the web at [www.trb.org](http://www.trb.org)) retains the color versions.

  
**PART 1**

# Overview

The first three sections in Part 1 describe the different levels of planning and preliminary engineering analyses and the potential role of the HCM in supporting these analyses. These sections serve as gateways to the remainder of the Guide:

- A. Introduction
  - a. Scope of the Guide
  - b. Target audience
  - c. How to use the Guide
  - d. The hierarchy of analysis methods
- B. Medium-level (facility-specific) analyses
  - a. Project traffic and environmental impact studies
  - b. Applications of default values
- C. High-level analyses
  - a. Screening and scoping studies
  - b. Long- and short-range areawide transportation planning
  - c. System performance monitoring

The remaining four sections in Part 1 provide reference information applicable to many of the planning and preliminary engineering applications described in the Guide:

- D. Working with traffic demand data
  - a. Selecting an analysis hour
  - b. Converting daily volumes to shorter timeframes
  - c. Seasonal adjustments to traffic volumes
  - d. Rounding traffic volumes
  - e. Differences between observed volumes and actual demand
  - f. Constraining demand for upstream bottleneck metering
  - g. Generating turning-movement volume estimates from link volumes
- E. Predicting intersection traffic control
  - a. Manual on Uniform Traffic Control Devices
  - b. Graphical method
- F. Default values to reduce data needs
  - a. When to consider default values
  - b. Sources of default values
  - c. Developing local default values
- G. Service volume tables to reduce analysis effort
  - a. Description
  - b. When to consider service volume tables
  - c. Sources of generalized service volume tables



# A. Introduction

## 1. Overview

The *Highway Capacity Manual* (HCM) is commonly used by transportation agencies to evaluate the current or forecast operations of roadway facilities. Less well known is that the HCM can also be used to cost-effectively and reliably support agencies' planning, programming, and management decisions.

This *Planning and Preliminary Engineering Applications Guide to the HCM* ("Guide") is intended as a reference and educational resource on best practices for applying HCM methods to a variety of planning and preliminary engineering applications. It is designed to improve planning practice by identifying appropriate techniques for utilizing the HCM in planning and preliminary engineering analyses and to illustrate these techniques through the use of case studies. It is intended to be used by planners, engineers, and system analysts at various stages of the system management, operation, planning, and project development process.

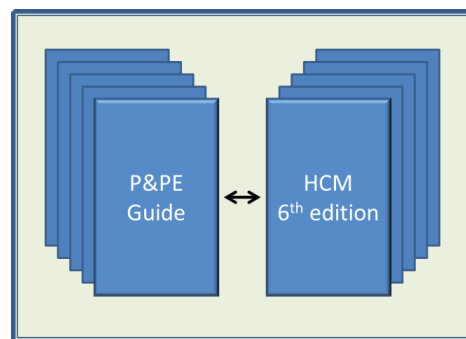

## 2. Scope of the Guide

### Definitions

The HCM defines planning analyses as those “generally directed toward broad issues such as initial problem identification (e.g., screening a large number of locations for potential operations deficiencies), long-range [needs] analyses, and regional and statewide [system] performance monitoring.” It defines preliminary engineering analyses as those supporting (1) planning decisions on roadway design concept and scope, (2) alternatives analyses, and (3) proposed system-wide policies.

### Applications

The Guide can support statewide and local application of HCM methods to planning and preliminary engineering evaluations of current and future traffic operations and multimodal level of service. Topics covered in the Guide include:

- The potential application of HCM and HCM-consistent methods to a broad spectrum of planning and preliminary engineering applications (including different stages of project planning and development, various study area sizes, under and over capacity conditions, and system performance monitoring);
- The appropriate use of default values when applying HCM methods, along with techniques for developing and using local default values;

## 4 Planning and Preliminary Engineering Applications Guide to the Highway Capacity Manual

- The coordinated use of the HCM with simulation models, travel demand forecasting models, mobile source emissions models, multimodal transportation analysis tools, and other planning tools;
- The ability to incorporate and test more factors in an analysis than traditional planning tools allow, by integrating HCM methods with existing tools; and
- The simplification of calculations to produce a more transparent, quicker evaluation and review process, while not sacrificing the accuracy of the conclusions that are drawn.

Similar to the HCM, the Guide describes methods for estimating a variety of multimodal transportation performance measures, including traffic speed, travel time, delay, density, and queues, as well as auto, truck, bus, bicycle, and pedestrian level of service (LOS). Unlike the HCM, the Guide focuses on methods appropriate for the amount and quality of data typically available to planning analyses, as well as the available computational resources.

The Guide is *not* intended to replace the HCM, nor to specify what constitutes good planning and preliminary engineering analysis. In many cases, current local practice may be superior to the guidance included in the Guide because local practices have been validated for local conditions (all of which cannot be reasonably anticipated in any single national guide).

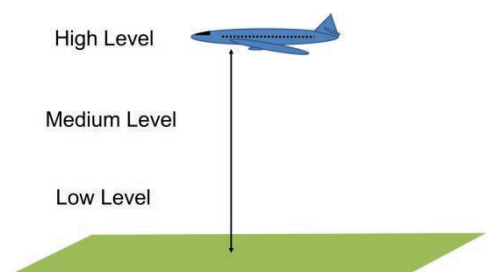

### Levels of Analysis

Planning and preliminary engineering covers a wide spectrum of possible levels of analysis. At the highest level (visualize a plane flying at high altitude), the area covered by the analysis is large, but the degree of detail (precision) for any particular segment of road is low. This is a typical characteristic of regional areawide studies, regional plans, statewide plans, and sketch planning and screening studies.

HCM analyses using a mix of default and measured inputs are examples of mid- or medium-level analysis. The area covered is significantly reduced, to that of a single roadway facility, segment, or intersection, but the degree of precision in the estimated performance is much improved. Even so, the performance estimates are still at a macroscopic level (i.e., the estimates describe traffic operations averaged over a period of time and do not consider individual vehicles in the traffic stream).

A microsimulation analysis provides an extremely low-level (highly focused but highly detailed) performance analysis. In general, the data and time requirements to conduct a low-level analysis, as well as the high precision of the results, are incompatible with the needs of a typical planning study. Consequently, this Guide focuses on high- and medium-level applications of the HCM to planning and preliminary engineering.

### Relationship of the Guide to the Project Life Cycle

Exhibit 1 illustrates that a roadway project goes through many stages from concept to construction to operation. Initially, the potential need for a project is identified through a long- or short-range areawide or corridor-based plan. These studies cover relatively large areas, and the level of precision for any given roadway element is relatively low. The Guide describes how to apply HCM methods in support of these types of plans.

Later, if selected for further development and if funding is available, a project will move into the project initiation and project clearance stages, and facility-specific project and environmental plans will be developed. These studies cover more focused areas and have a higher level of precision. Again, the Guide describes how to apply HCM methods in the development of these plans.

**Exhibit 1. Scope of the *Planning and Preliminary Engineering Applications Guide to the HCM*.**

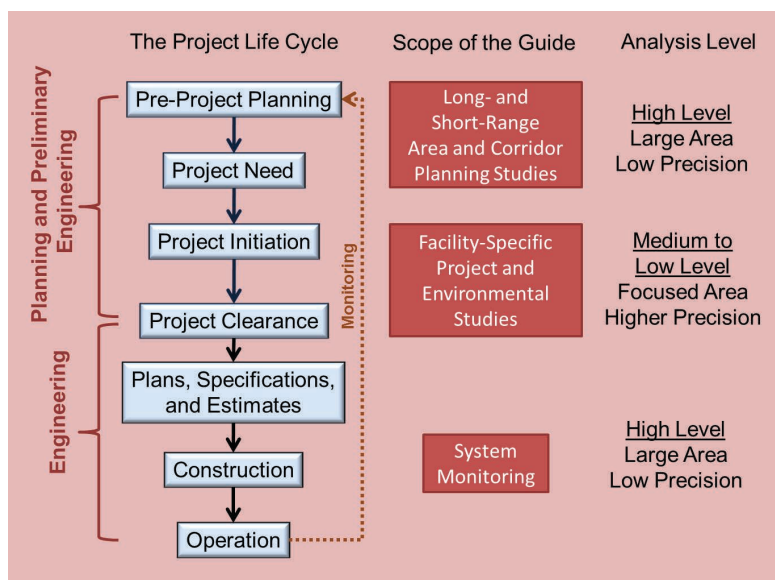

Once the project moves into final design, it moves out of the realm of planning and preliminary engineering. However, once the project is constructed and in operation, it becomes part of the overall transportation system and a subject for system performance monitoring. As performance monitoring covers large areas at low levels of precision, planning and preliminary engineering techniques for estimating roadway operations performance measures again become applicable.

### 3. Target Audience

The range of potential users for the Guide includes every technical professional involved in estimating the need for, and feasibility of, highway capacity, monitoring, management, and operations investments. This audience includes all current HCM users, plus planners and travel demand modelers who may not consider themselves HCM users but who have used pieces of the HCM in the past. University students in transportation planning and transportation engineering programs are also part of the target audience.

### 4. How to Use the Guide

The Guide is intended primarily as a resource for practitioners. As such, it is not intended to be read cover to cover. Instead, its organization is designed to help practitioners quickly find information on how to apply the HCM to a particular planning need. The Guide is divided into four parts:

- *Part 1, Overview*, describes typical planning and preliminary engineering analysis needs, identifies points where an HCM analysis can provide useful inputs to the analysis, and points the reader to the appropriate part of the Guide for guidance on how to apply, and adapt as necessary, HCM methods for use in the analysis. Part 1 also contains several sections that are cross-referenced throughout the Guide. These sections address: working with traffic demand data, predicting future intersection traffic control, using default values to reduce data needs, and using service volume tables to reduce computational effort.

## 6 Planning and Preliminary Engineering Applications Guide to the Highway Capacity Manual

- *Part 2, Medium-Level Analysis Methods*, presents guidance on applying and adapting HCM methods for medium-level planning analyses, those planning analyses that focus on a single facility and its component interchanges, intersections, and segments. The sections in Part 2 are organized according to the system elements (e.g., freeway facility, signalized intersection) used by the HCM and are cross-referenced from the HCM. These sections describe typical planning needs for these system elements and present simplified methods for calculating a variety of performance measures commonly used in planning and preliminary engineering studies.
- *Part 3, High-Level Analyses*, presents guidance on extending HCM methods for high-level planning analyses involving roadway corridors, large areas, and entire transportation systems. Part 3 also covers the use of service volume tables and volume-to-capacity ratios to quickly identify the needed geographic scope of an analysis.
- *Part 4, Case Studies*, illustrates the application of the HCM techniques described in the Part 2 and 3 sections to three types of studies: (1) a freeway master plan, (2) the development of bus rapid transit service on an urban street, and (3) a long-range countywide transportation plan.

To help distinguish cross-references within this Guide with cross-references to the HCM, the Guide is organized into lettered sections (e.g., Section A, Introduction) to distinguish them from the HCM's numbered chapters (e.g., Chapter 1, HCM User's Guide). Although having access to the latest edition of the HCM is certainly helpful for learning about the supporting research, theory, and computational details of HCM methods, in many cases the information needed to apply the HCM in a particular planning context is provided within the Guide itself.

## 5. The Hierarchy of Analysis Methods

In some cases the Guide provides one or more alternative methods that supplement the standard HCM method for estimating a particular performance measure. These alternative methods are designed to better balance the required analysis resources against the accuracy requirements of different levels of planning analysis. For example, at a high, sketch-planning level, or for regional demand modeling purposes, it may be satisfactory to estimate free-flow speeds (i.e., average vehicle speeds under low-volume conditions) for all facilities on the basis of the posted speed limits. For environmental clearance analyses of specific improvements to specific facilities (an example of a preliminary engineering analysis), it may be more appropriate to use the HCM methods for estimating free-flow speeds. Thus, the Guide may provide several methods for estimating performance measures and will provide advice on which level of planning or preliminary engineering analysis a given method is most suitable for, given the particular analysis objectives.

Generally, when one can measure a performance measure directly in the field, it is usually (but not always) better than estimating that measure indirectly using the methods in the HCM or this Guide. When conditions make it difficult to accurately measure performance in the field, then the Guide takes the perspective that an HCM analysis using field-measured inputs is most accurate, followed by an HCM analysis using a mix of default values and field-measured inputs, followed by the alternative analysis methods described in the Guide. The general hierarchy of methods is shown in Exhibit 2.

In general:

- Field measurement is most reliable if it can be done cost-effectively and accurately. Note that the resources required to directly measure performance in the field can vary widely, depending on the performance measure and the geographic and temporal scope of the measurement.
- Microsimulation modeling of performance is the next most accurate approach if adequate resources are invested in calibrating and validating the model.
- HCM estimates of performance using field-measured inputs are generally the next most accurate.



**Exhibit 2. Relative effort and precision of traffic performance estimation methods.**

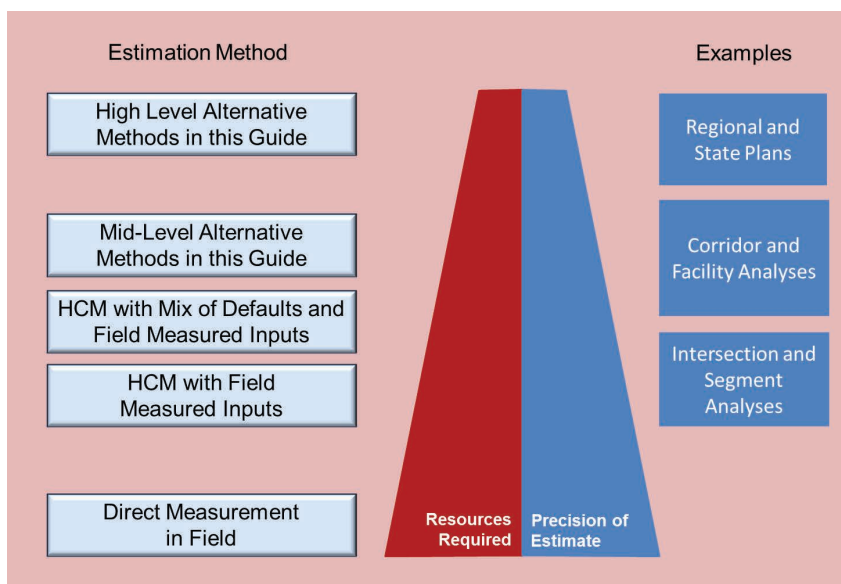

- HCM estimates of performance using a mix of default values and field-measured inputs are usually the next most accurate.
- Alternative planning methods described in the Guide for estimating performance will usually be the least accurate, but will be among the most cost-effective methods for obtaining estimates of existing and future performance.

It may be infeasible, or require a disproportionate amount of resources, to employ more detailed analysis approaches such as microsimulation. For example, the analyst may need to screen many possible scenarios or solutions (20, 30, or more at times) prior to conducting a more detailed simulation analysis. Even if the analyst has all of the data available to conduct a simulation analysis, it may not be practical or useful to use the microsimulation process for a screening-level analysis. In such circumstances, the more detailed analysis methods may not be practical for the initial analysis process. The analyst may use the higher level methods to screen and document the analysis of the initial alternatives and then apply the more detailed methods to the two or three scenarios that pass the initial screening process.



## B. Medium-Level (Facility-Specific) Analyses

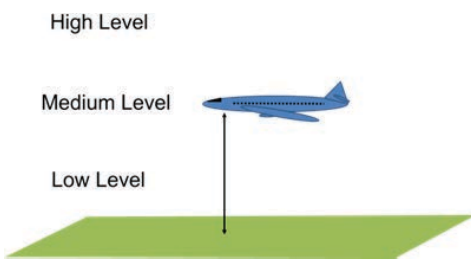

### 1. Overview

This section describes planning and preliminary engineering analyses that are performed at the medium level of analysis. This level of analysis typically focuses on a specific facility, or specific segments, interchanges, and intersections on that facility. Examples of these types of studies include preliminary or conceptual design studies to determine the number of required lanes and traffic, transit, and environmental impact studies required to obtain project approval and environmental clearance.

While the data requirements of this level of analysis can be relatively extensive, the HCM, the Guide, and other publications such as the *Transit Capacity and Quality of Service Manual* (Kittelson & Associates et al. 2013) provide default values for some of the required inputs to assist in a planning or preliminary engineering analysis.

### 2. Project Traffic and Environmental Impact Studies

A project traffic and environmental impact study focuses on predicting the impacts of one or more specific transportation improvement or land development projects. Examples of typical analysis guidelines for these types of studies include Oregon Department of Transportation (2005); CH2M Hill (2006); and Association of Environmental Professionals (2014).

#### Typical Project Impact and Alternatives Analysis Process

Typical project traffic and environmental impact analyses employ comparatively simple analysis techniques to add project-generated traffic onto existing or forecasted future traffic, and then evaluate the impacts on highway facility performance. The impact analysis may extend to other travel modes, such as trucks, buses, bicycles, and pedestrians, and may extend to include vehicle emissions analysis for air quality analyses, and a noise analysis. The objectives of these impact studies are to identify the project's performance impacts by travel mode, to determine whether those impacts are significant, to generate mitigation measures for those impacts, and to assess whether those mitigations can reduce the project impacts to a less-than-significant level.

#### Typical Tools Used In Project Impact and Alternatives Analysis

Traffic, transit, and environmental impact analyses typically employ relatively simple manual traffic forecasting techniques and invest most of their effort in employing HCM-type analysis tools for predicting the resulting highway performance for each travel mode (auto, truck, bus, bicycle, and pedestrian).

Microsimulation modeling may be employed for the operations analysis of more complex projects in which the interactions between queuing and operation performance are expected to be significant.

If a regional demand model is used to assist in the demand forecasting, then some of the methods described in Part 3 of the Guide on high-level methods (Section R, Areas and Systems) may be useful for improving the demand model forecasts used in the project impact analysis.

Air quality and noise analysis models may use the forecasted traffic volumes as inputs for estimating the project’s air and noise impacts.

### Basic Data Needs for Project Impact and Alternatives Analysis

The basic data needs for an impact analysis include:

- Project description
- Expected influence area for project impacts
- Existing and forecasted demands at key intersections, freeway mainline sections, and ramps
- Highway network data
  - Segments (length, facility type, lanes, geometric cross section)
  - Intersections (turn lanes, geometric cross-section, signal control settings)
- Transit data
  - Routes, frequencies, bus stop characteristics
- Bicycle and pedestrian data
  - Street and intersection cross-sections, bicycle, and pedestrian facility characteristics

### How the HCM Can Support Project Impact and Alternatives Analyses

The HCM can be used to support the project impact analysis tasks shown in Exhibit 3. This exhibit lists the sections of Parts 2 and 3 of the Guide where the specific methods are described.

**Exhibit 3. Project impact analysis task cross-reference table.**

Project Impact and Alternatives Analysis Task	Parts 2 and 3 Reference	Part 4 Case Studies
<b>Input to travel demand models (if used)</b>		
• Estimate highway capacities and free-flow speeds	Section R	Case Study 3.1
<b>Traffic assignment module within travel demand model (if used)</b>		
• Apply volume–delay functions for estimating congested speeds	Section R	Case Study 3.2
<b>Input to microsimulation model (if used)</b>		
• Estimate free-flow speeds	Sections H-N	None
<b>Microsimulation model validation and error checking (if used)</b>		
• Estimate capacity for error checking simulated bottlenecks	Sections H-N	None
<b>Project impact and alternatives analyses</b>		
• Estimate segment speeds for air quality and noise analyses	Sections H-N	Case Studies 1.3, 2.4
• Estimate auto intersection utilization (v/c ratios)	Sections H-N	Case Studies 2.2, 2.3
• Estimate delay	Sections H-N	Case Study 2.4
• Estimate queuing	Sections H-N	Case Studies 1.5, 2.5
• Interpret results	Sections H-N	Case Studies 1, 2
• Analyze travel time reliability	Sections H, K	Case Study 1.6
• Estimate multimodal quality of service for transit, bicycles, and pedestrians	Section O	Case Study 2.6
• Estimate truck LOS	Section P	None
<b>Corridor analyses</b>	Section Q	None

The exhibit then lists the Part 4 case studies where the applications of the methods to typical planning analyses are illustrated.

### 3. Applications of Default Values

Default values can be used for many traffic characteristics parameters (e.g., percentage heavy vehicles, peak hour factor) required in a typical HCM analysis. Other defaults may be used to characterize the facility's geometric design (e.g., lane widths, lateral clearances) when the analyst is confident that the facility generally meets (or will meet) agency standards.

Default values for less-critical inputs to HCM analyses are provided in each procedural chapter of the HCM. Additional values are provided in *NCHRP Report 599* (Zegeer et al. 2008). Both documents provide sensitivity analyses of the effects of different input values on the analysis results.

The Guide provides guidance on the selection and use of default values in Section F, Default Values to Reduce Data Needs. In addition, tables in the individual Part 2 and Part 3 sections of the Guide provide suggested default values for different system elements (e.g., areas, freeway facilities, signalized intersections).

### 4. References

- Association of Environmental Professionals. *California Environmental Quality Act, 2014 CEQA Statute and Guidelines*. Palm Desert, Calif., Jan. 2014.
- CH2M Hill. *Best Practices for Traffic Impact Studies*. Oregon Department of Transportation, Salem, June 2006.
- Kittelson & Associates, Inc.; Parsons Brinckerhoff; KFH Group, Inc.; Texas A&M Transportation Institute; and Arup. *TCRP Report 165: Transit Capacity and Quality of Service Manual*, 3rd ed. Transportation Research Board of the National Academies, Washington, D.C., 2013.
- Oregon Department of Transportation. *2005 Development Review Guidelines*. Salem, 2005.
- Zegeer, J. D., M. A. Vandehey, M. Blogg, K. Nguyen, and M. Ereti. *NCHRP Report 599: Default Values for Highway Capacity and Level of Service Analyses*. Transportation Research Board of the National Academies, Washington, D.C., 2008.



## C. High-Level Analyses

### 1. Overview

This section describes planning and preliminary engineering analyses that are performed at a high level of analysis. These analyses typically cover large areas and systems of facilities. These high-level analyses may also be performed as “screening analyses,” when one is attempting to determine what the geographic and temporal limits should be for a more detailed level of analysis.

Examples of these types of studies include long- and short-range regional transportation plan analyses and transportation system performance monitoring studies. These types of studies cover a large number of roadway miles for a given investment in data collection and analysis resources.

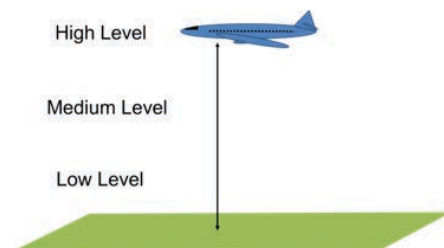

### 2. Screening and Scoping Studies

Scoping studies seek to quickly determine the geographic and temporal limits required for more detailed analyses. Alternative screening studies seek to quickly identify which improvement alternatives may be worthy of further consideration and analysis.

#### Role of the HCM in Screening and Scoping

The service volume tables in the HCM can be used to identify facilities, segments, and intersections not meeting (or not likely to meet) the agency’s LOS standards for autos, trucks, transit buses, bicyclists, and pedestrians. Tables of capacities by facility type can be constructed for local facility conditions using local defaults and the HCM procedures. These tables then can be used to quickly identify volume-to-capacity (v/c) problems for individual facilities, segments, and intersections, as well as to evaluate the reserve capacity available in a corridor. Improvement alternatives can be quickly compared based on their effect on facility or corridor v/c ratios to identify those alternatives delivering a target v/c ratio.

Exhibit 4 lists the specific tasks that can be supported by the HCM.

#### How to Use the Guide for Screening and Scoping

Exhibit 4 lists the sections of Parts 2 and 3 where the specific methods are described. This table then lists the Part 4 case studies where the applications of the methods to typical planning analyses are illustrated.

**Exhibit 4. Screening and scoping task cross-reference table.**

Screening and Scoping Task	Parts 2 and 3 References	Part 4 Case Studies
<b>Identify potential level of service (LOS) hot spots</b> <ul style="list-style-type: none"> <li>• Screen for auto LOS problems</li> <li>• Screen for truck LOS problems</li> <li>• Screen for transit, bicycle, and pedestrian LOS problems</li> </ul>	Sections H-N Section P Section O	Case Studies 1.4, 2.4 None Case Study 2.6
<b>Identify potential capacity problems: auto</b>	Sections H-N	Case Studies 1.1, 1.2, 2.1, 2.2, 2.3
<b>Preliminarily evaluate improvement alternatives</b> <ul style="list-style-type: none"> <li>• Auto improvements</li> <li>• Truck improvements</li> <li>• Transit, bicycle, and pedestrian improvements</li> </ul>	Sections H-N Sections H-N Section O	Case Study 1.7 None Case Study 2.6

### 3. Long- and Short-Range Areawide Transportation Planning

Long-range areawide transportation planning, specifically the production of state and regional long-range transportation plans (LRTPs), defines the vision for the region’s or state’s transportation systems and services for a 20-year or longer period. Short-range areawide planning focuses on just as large an area, but on a shorter time frame. “In metropolitan areas, the LRTP is the official multimodal transportation plan addressing no less than a 20-year planning horizon that is developed, adopted, and updated by the metropolitan planning organization (MPO) through the metropolitan transportation planning process (MTPP)” (Federal Highway Administration 2007).

#### Typical Areawide Planning Analysis Process

In the long-range transportation planning process, planners assess future investments on the basis of the performance of the freeways and streets that make up a regional transportation system. The performance of the system and its components is often estimated through a travel demand and analysis forecasting process. This process requires a variety of inputs and analytical methodologies, which the HCM can provide.

#### Typical Tools Used in the Areawide Planning Analysis

A combination of specialized travel demand models, geographic information systems (GIS), and spreadsheets are typically used when conducting analyses for LRTPs. The region to be modeled is divided into zones and highway and transit networks are coded. The GIS, in combination with a land-use model, is used to develop forecasts of socioeconomic activity (population, employment, etc.) for the region.

#### Basic Data Needs for Areawide Planning Analysis

Data needs are kept relatively simple (in terms of different types of data), but end up being massive in size because of the large areas often covered in regional transportation plans. The basic data needs for LRTPs include:

**Exhibit 5. Areawide planning analysis task cross-reference table.**

Areawide Planning Analysis Task	Part 3 Reference	Part 4 Case Study
<b>Input to travel demand models</b>		
<ul style="list-style-type: none"> <li>• Estimate highway segment capacities and free-flow speeds</li> </ul>	Section R	Case Study 3.1
<b>Traffic assignment module within the travel demand model</b>		
<ul style="list-style-type: none"> <li>• Apply volume–delay functions to estimate congested speeds</li> </ul>	Section R	Case Study 3.2
<b>Post-processing travel demand model outputs</b>		
<ul style="list-style-type: none"> <li>• Obtain more accurate speed estimates for air quality analyses</li> </ul>	Section R	Case Study 3.3
<ul style="list-style-type: none"> <li>• Spot auto volume-to-capacity and LOS hot spots (quick screening)</li> </ul>	Section R	Case Study 3.3
<ul style="list-style-type: none"> <li>• Estimate delay based on agency policy</li> </ul>	Section R	Case Study 3.3
<ul style="list-style-type: none"> <li>• Estimate queuing</li> </ul>	Section R	Case Study 3.3
<ul style="list-style-type: none"> <li>• Interpret results</li> </ul>	Section R	Case Study 3.3
<ul style="list-style-type: none"> <li>• Analyze travel time reliability</li> </ul>	Section R	Case Study 3.4
<ul style="list-style-type: none"> <li>• Estimate multimodal quality of service for autos, trucks, transit, bicycles, and pedestrians</li> </ul>	Section R	None
<b>Corridor analyses</b>	Section Q	None

- Socioeconomic data by traffic analysis zone (e.g., population, employment)
- Highway network data
  - Segments (e.g., length, facility type, lanes, capacity, free-flow speed)
  - Connectivity
- Transit network data
  - Segments, routes, frequencies, transfer points

### How the HCM Can Support Areawide Planning Analyses

The HCM can be used to support the LRTP planning analysis tasks shown in Exhibit 5. This exhibit lists the sections of Part 3 of the Guide where the specific methods are described. This exhibit then lists the Part 4 case studies where the applications of the methods to typical planning analyses are illustrated.

## 4. System Performance Monitoring

Highway system performance monitoring is the measurement of highway use and operating characteristics under existing conditions (Federal Highway Administration 2014a).

### Performance Monitoring Context

The Moving Ahead for Progress in the 21st Century Act (MAP-21) established a “performance and outcome based program for states to invest resources in projects that collectively will make progress toward the achievement of national goals” (Federal Highway Administration 2014b). MAP-21 requires the Federal Highway Administration to work with stakeholders to identify performance measures tied to seven goal areas for the federal-aid highway program:

- Safety,
- Infrastructure Maintenance,

**Exhibit 6. Performance monitoring task cross-reference table.**

Performance Monitoring Task	Part 3 Reference	Part 4 Case Study
<b>Estimate monitoring site capacities and free-flow speeds</b>	Section R4	Case Study 3.1
<b>For volume-only monitoring sites</b>		
• Estimate speeds	Section R5	Case Study 3.2
<b>For travel time-only monitoring segments</b>		
• Estimate congestion	Section S3	None
<b>Performance analyses</b>		
• Auto and truck VMT by LOS	Section R5	None
• Estimate delay	Section R5	Case Study 3.3
• Estimate queuing	Section R5	Case Study 3.3
• Analyze travel time reliability	Section R5	Case Study 3.4
• Estimate multimodal LOS for transit, bicycles, and pedestrians	Section R5	None
• Estimate truck LOS	Section R5	None

- Congestion Reduction,
- System Reliability Improvement,
- Freight Movement and Economic Vitality,
- Environmental Sustainability, and
- Reduced Project Delivery Delays.

Of these seven goal areas, the HCM can assist agencies in monitoring highway performance relevant to the three goal areas of Congestion Reduction, System Reliability Improvement, and Freight Movement.

### Role of the HCM in Performance Monitoring

The HCM can be used to compute the performance measures not directly monitored at a monitoring site. It can be used to spot data errors and inconsistencies. It can be used to impute missing performance data. Exhibit 6 lists the specific performance monitoring tasks that can be supported by the HCM.

### How to Use the Guide for Performance Monitoring

Exhibit 6 lists which methods are described in Sections R and S of the Guide. This table then lists the example problems in the Part 4 case studies where the applications of the methods to typical planning analyses are illustrated.

## 5. References

Federal Highway Administration. *The Transportation Planning Process Briefing Book: Key Issues for Transportation Decisionmakers, Officials, and Staff*. FHWA-HEP-07-039. Washington, D.C., 2007.

Federal Highway Administration. Highway Performance Monitoring System website. <https://www.fhwa.dot.gov/policyinformation/hpms.cfm>. Accessed September 2, 2014(a).

Federal Highway Administration. MAP-21 Performance Management Fact Sheet website. <https://www.fhwa.dot.gov/map21/factsheets/pm.cfm>. Accessed September 2, 2014(b).





## D. Working with Traffic Demand Data

### 1. Overview

The traffic demand data available for a planning or preliminary engineering analysis may require adjusting before it can be used with an HCM planning method. For example, annual average daily traffic (AADT) volumes may need to be converted to hourly volumes representative of the conditions of interest to the analysis (e.g., peak hour, peak season volumes). This section provides guidance on these types of demand volume adjustments.

The analyst should be aware that state and local traffic forecasting and analysis guidelines and policies often specify the methods that should be used to adjust demand volumes, as well as the analysis hour(s) that should be analyzed. It is important for planning and preliminary engineering analyses to follow these local guidelines, in part because any subsequent operational analyses will apply the same guidance. The goal is for the more detailed operations study to focus on the specific issues identified by the earlier, more-general planning study, and not to have to redo prior work because the wrong procedures were used. Therefore, *it is recommended that the analyst check whether state and local guidelines already exist prior to applying the guidance found in this section.*

*NCHRP Report 255* (Pedersen and Samdahl 1982) and *NCHRP Report 765* (CDM Smith et al. 2014) are good references on processing demand model forecasts for use in traffic analyses.

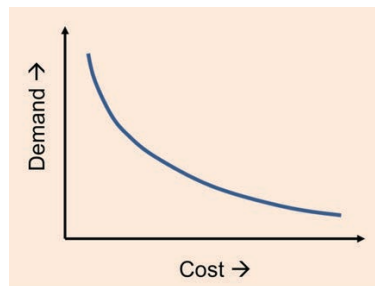

### 2. Selecting an Analysis Hour

One important decision when performing a traffic analysis is the selection of an analysis hour. This choice balances a transportation agency's desire to provide adequate operations during the large majority of hours of the year and its need to use its limited resources as efficiently as possible. AASHTO (2009) recommends the use of the 30th-highest hour of the year as a design hour, resulting in a few hours per year with (sometimes substantially) higher volumes, and many hours per year with lower volumes. Some agencies choose other analysis hours for cost-efficiency reasons; for example, Florida uses a combination of the 100th-highest hour (for areas under 50,000 population) and a typical weekday peak hour (for larger areas) (Florida DOT 2014). In some cases, the needs of the analysis may require using a non-weekday peak hour (e.g., special event planning, transportation planning for recreation areas). The choice of an analysis hour will affect the way traffic volumes may need to be adjusted for use with HCM methods.

### 3. Converting Daily Volumes to Shorter Timeframes

HCM methods work with hourly directional demand volumes as a starting point and typically analyze traffic flows during the peak 15 minutes of an analysis hour. Sometimes, however, the traffic demand volumes available for a planning analysis consist of AADTs. These must be

converted into peak hour directional flows. Three factors are used in this process: the *K*-factor (the proportion of AADT occurring during the analysis hour); the *D*-factor (the proportion of traffic in the peak direction during the analysis hour); and the peak hour factor (PHF, which converts design-hour volumes to the equivalent hourly flow that occurs during the peak 15 minutes).

In the case of “base-year” (existing) demands, the hourly and peak direction flows can often be directly measured. In the case of “future-year” demands (and base-year demands when demands could not be directly counted), it may be necessary to adopt peaking and directional factors to convert daily traffic forecasts to the required hourly demands by direction.

### K-Factor

The *K*-factor converts AADT to analysis hour volumes. It is the percentage of AADT occurring during the analysis hour. The selection of an appropriate *K*-factor is very important, as selecting a value that is too high can result in too many locations being identified as not meeting roadway operations standards (as the resulting estimated hourly volumes are too high), while selecting a value that is too low can result in some problem locations not being identified (because the estimated hourly volumes are too low). The former may result in unnecessary follow-up work and potentially too bleak a picture of future conditions, while the latter may result in potentially important problems going undetected.

For many rural and urban highways, the *K*-factor falls between 0.09 and 0.10, but it also can fall outside this range. For highways with strongly peaked demand, the *K*-factor may exceed 0.10. Conversely, for highways with consistent and heavy flows for many hours of the day, the *K*-factor is likely to be lower than 0.09. In general,

- The *K*-factor decreases as the AADT on a highway increases;
- The *K*-factor decreases as development density along a highway increases; and
- The highest *K*-factors occur on recreational facilities, followed by rural, suburban, and urban facilities, in descending order (HCM 2016).

In addition, the *K*-factor will be higher when a 30th-highest hour is chosen as the analysis hour ( $K_{30}$ ) than when the 50th- ( $K_{50}$ ) or 100th-highest hour ( $K_{100}$ ) is used. The *K*-factor should be determined, if possible, from local data for similar types of facilities with similar demand characteristics. Data from the automatic traffic recorders maintained by state DOTs and other transportation agencies are good sources for determining *K*-factors. Exhibit 7 presents illustrative  $K_{30}$  values, on the basis of average data from Washington State that demonstrate how *K*-factors decrease as AADT increases (HCM 2016). Exhibit 7 also shows standard *K*-factors specified by the Florida DOT (2013) for analyses of state highways.

Note that *K*-factors can and do change as traffic congestion changes. Thus, base-year and future-year *K*-factors may differ. *K*-factors may also vary between urban and rural areas. The analyst may

**Exhibit 7. Illustrative *K* values.**

Washington State DOT		Florida DOT	
AADT	Average $K_{30}$	Area Type	Standard <i>K</i> -Factor
0–2,500	0.151	Urbanized/Transitioning	0.090
2,500–5,000	0.136	Large Urbanized	0.080-0.090
5,000–10,000	0.118	Urban Freeway	0.105
10,000–20,000	0.116	Urban Highway	0.090
20,000–50,000	0.107	Urban Arterial	0.090
50,000–100,000	0.091	Rural Freeway	0.105
100,000–200,000	0.082	Rural Highway	0.095
>200,000	0.067	Rural Arterial	0.095

Sources: Washington State DOT (2008) in HCM (2016), Exhibit 3-11; Florida DOT (2013), p. 80.

**Exhibit 8. Illustrative *D*-factor values.**

Freeway Type	<i>D</i> -Factor
Rural–intercity	0.59
Rural–recreational and intercity	0.64
Suburban circumferential	0.52
Suburban radial	0.60
Urban radial	0.70
Intraurban	0.51

Source: 2007 Caltrans data in HCM (2016), Exhibit 3-12.

consider sensitivity analyses to address uncertainty in future-year *K*-factors. Toll facilities may have different *K*-factors than similar untolled facilities. Additional references on *K*-factors can be found in the literature (e.g., Dykstra et al. 2011).

### ***D*-Factor**

The *D*-factor represents the proportion of traffic in the peak direction on a roadway during the peak hour. Radial roadways into a city center and recreational and rural routes are often subject to strong directional imbalances during peak hours. In contrast, circumferential roadways and routes connecting major cities within a metropolitan area may have very balanced flows during peak periods. Exhibit 8 presents illustrative directional distributions derived from selected California freeways (HCM 2016).

Note that *D*-factors can and do change as traffic congestion changes. Thus, base and future-year *D*-factors may differ. The analyst may consider sensitivity analyses to address uncertainty in future-year *D*-factors.

### **Directional Design-Hour Volume**

The directional design-hour volume (DDHV) is the starting point for many HCM-based analyses. It can be calculated by multiplying the AADT by the *K*- and *D*-factors, as shown in Equation 1 (HCM 2016).

$$DDHV = AADT \times K \times D \quad \text{Equation 1}$$

where

*DDHV* = directional design-hour volume (veh/h),

*AADT* = annual average daily traffic (veh/day),

*K* = proportion of *AADT* occurring in the peak hour (decimal), and

*D* = proportion of peak hour traffic in the peak direction (decimal).

### **Peak Hour Factor**

Most HCM methods analyze conditions during the peak 15 minutes of the peak hour. Although this may seem to be a fairly short timeframe on which to base roadway design and control decisions, it should be kept in mind that the effects of roadway operations breaking down at a single location can last for much longer periods of time (potentially hours in larger metropolitan areas) and that the ripple effects of a breakdown can extend to other roadway segments and intersections. Therefore, the HCM analyzes the peak 15 minutes, to evaluate the worst 15-minute period within the analysis hour that can lead to facility breakdowns.

In the absence of direct measurements of peak 15-minute volumes (a common situation for planning analyses), a PHF is used to convert hourly demand volumes into an hourly flow

rate equivalent to the peak-15-minute volume being sustained for an entire hour. The PHF is calculated as shown in Equation 2, with the peak-15-minute flow rate calculated as shown in Equation 3 (HCM 2016).

$$PHF = \frac{V}{4 \times V_{15}} \quad \text{Equation 2}$$

$$v = \frac{V}{PHF} \quad \text{Equation 3}$$

where

$PHF$  = peak hour factor (decimal),

$V$  = hourly volume (veh/h),

$V_{15}$  = volume during the peak 15 min of the analysis hour (veh/15 min), and

$v$  = flow rate for a peak 15-min period (veh/h).

As with the  $K$ -factor, the selection of an appropriate PHF strongly influences the accuracy of the analysis results.

For high-level planning analyses it is often appropriate, given the amount of uncertainty in some of the inputs (e.g., demand), to evaluate average hourly conditions. In these cases, the PHF is set to 1.00. For medium-level preliminary engineering studies, it may be more appropriate to use either field-measured PHFs or the default PHFs suggested in the HCM or *NCHRP Report 599* (Zegeer et al. 2008).

#### 4. Seasonal Adjustments to Traffic Volumes

Seasonal adjustments to traffic volumes may be appropriate for roadways showing high “seasonality” in their demand. Sometimes when peak hour or peak-15-minute traffic counts are available for a planning or preliminary engineering analysis, the time of year when the counts were made may not correspond to the desired analysis hour. While it is preferable to avoid using counts where large seasonal adjustments are required, in cases when the available count falls outside the peak season, the count may need to be adjusted to represent analysis hour volumes.

The basic adjustment process is to factor the count by the ratio of (1) the average monthly volume for a month reflective of the analysis hour to (2) the average monthly volume during the month when the count was made. Data from the automatic traffic recorders maintained by state DOTs and other transportation agencies are good sources for average monthly traffic volumes. Alternatively, tables of monthly factors (the ratio of monthly average volume to AADT) for each month of the year for specific count stations or for particular types of facilities may be available from transportation agencies (again, based on automatic traffic recorder data). In these cases, a count can be factored by the ratio of the monthly factor for a month reflective of the analysis hour and the monthly factor for the month when the count was made.

#### 5. Rounding Traffic Volumes

The traffic volumes used for planning and preliminary analyses are often estimates. Therefore, to avoid giving the impression of a greater degree of accuracy than is warranted, AASHTO (2009) recommends rounding traffic volumes as follows:

- Volumes under 1,000 should be rounded to the nearest 10.
- Volumes between 1,000 and 9,999 should be rounded to the nearest 100.
- Volumes of 10,000 or more should be rounded to the nearest 1,000.

## 6. Differences Between Observed Volumes and Actual Demand

HCM methods typically require *demand volumes*: the traffic volume that would use a roadway during an analysis hour in the absence of any capacity constraints (i.e., bottlenecks). Field measurements of traffic volumes produce *observed volumes*: the traffic volume that is capable of using a roadway during an analysis hour. When demand is less than capacity (*undersaturated* flow) and no bottlenecks exist upstream, then the demand volume can be assumed to be equal to the observed volume. When demand exceeds capacity (*oversaturated* flow), then determining demand requires a count of the traffic joining the queue upstream of the bottleneck, as opposed to a count of traffic departing the bottleneck (Peduto et al. 1977). However, it may not be easy to determine how much of the traffic joining the queue is bound for the bottleneck location once the queue extends past the previous intersection or interchange (as some traffic may intend to exit the roadway at that point) (HCM 2016).

## 7. Constraining Demand for Upstream Bottleneck Metering

Transportation planning models produce demand volume estimates. However, when a model does not account for the metering effect of bottlenecks (i.e., is not capacity-constrained), it will produce estimates of demand downstream of a bottleneck that are higher than would actually be observed. This can result in HCM-based methods predicting LOS F for situations in which the traffic physically cannot arrive at the study area.

The following procedure, adapted from Appendix F of FHWA's *Guidelines for Applying Traffic Microsimulation Modeling Software* (Dowling et al. 2004) can be used in a post-processing analysis of demand model outputs to constrain demand forecasts for segments downstream of a bottleneck.

### Step 1: Identify Gateway Capacities

The analyst should first identify the capacities of the facility or facilities at the gateways delivering traffic to the study HCM facility, segment, intersection, or area. A gateway is defined as a point where traffic enters or leaves the study area. These gateways cannot physically feed traffic to the HCM facility at a higher rate than their capacity. Any forecasted demands greater than the inbound capacity of a gateway should be reduced to the inbound capacity of the gateway.

### Step 2: Estimate Excess Demand at Inbound Bottlenecks

If the forecasted hourly demand in the inbound direction at a gateway exceeds its capacity, the proportion of the demand that is in excess of the available hourly capacity should be computed:

$$P = \frac{D - C}{C} \quad \text{Equation 4}$$

where

- $P$  = proportion of excess demand (decimal),
- $D$  = forecasted demand (veh/h), and
- $C$  = estimated capacity (veh/h).

### Step 3: Reduce Forecasted Demand within HCM Study Area

The forecasted hourly demands for the facilities and segments within the HCM study area that are downstream from the bottleneck should also be reduced. However, the reduction must take into account the traffic entering and exiting the facility within the study area.

It is suggested that the forecasted downstream demands be reduced in proportion to the reduction in demand that can get through the gateway, assuming that the amount of reduction in the downstream flows is proportional to the reduction in demand at the bottleneck. If the analyst has superior information (such as an origin–destination [O-D] table), then the assumption of proportionality should be overridden by the superior information. The gateway-constrained downstream demands are then obtained by summing the constrained gateway, off-ramp, and on-ramp volumes between the gateway and the downstream segment.

$$D_c = D_u \times (1 - P) \tag{Equation 5}$$

where

- $D_c$  = constrained demand for a downstream off-ramp or exit point (veh/h),
- $D_u$  = unconstrained demand forecast (veh/h), and
- $P$  = proportion of excess demand (decimal).

Exhibit 9 illustrates how the proportional reduction procedure would be applied for a single inbound gateway constraint that reduces the peak hour demand from 5,000 veh/h to 4,000 veh/h.

Starting upstream of the gateway, there is an unconstrained demand for 5,000 veh/h. Because the gateway has a capacity of 4,000 veh/h, the downstream capacity-constrained demand is reduced from the unconstrained level of 5,000 veh/h to 4,000 veh/h. Thus, 1,000 vehicles are stored at the gateway during the peak hour. Because it is assumed that the stored vehicles are intended for downstream destinations in proportion to the exiting volumes at each off ramp and freeway mainline, the downstream volumes are reduced by the same percentage as the percentage reduction at the bottleneck (20 percent). A 20-percent reduction of the off-ramp volume results in a constrained demand of 800 veh/h.

The on-ramp volume is unaffected by the upstream gateway bottleneck, so its unconstrained demand is unchanged at 500 veh/h. The demand that enters the segment downstream of the interchange is equal to the constrained demand of 4,000 veh/h leaving the gateway bottleneck, minus the 800 veh/h leaving the freeway on the off ramp, plus 500 veh/h entering the freeway at the on ramp, which results in a constrained demand of 3,700 veh/h for the downstream segment.

**Exhibit 9. Capacity-constraining demands entering and within HCM study facility.**

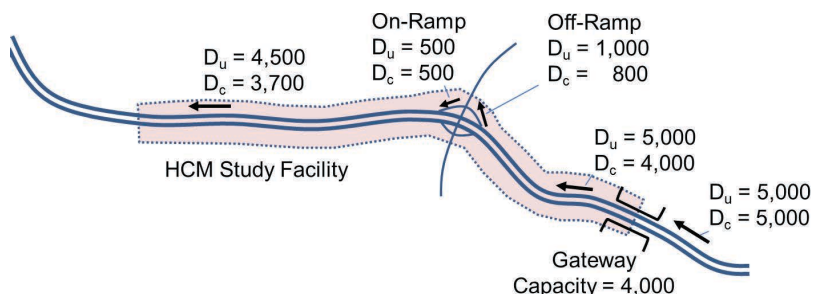

Notes:  $D_u$  = unconstrained demand,  $D_c$  = constrained demand.

#### Step 4: Caution When Working With Constrained Demands

The analyst should recompute the capacity-constrained demands for future scenarios that change one or more capacity constraints (such as adding a lane to a bottleneck). A scenario that eliminates a bottleneck may release demands that create new bottlenecks downstream. Once the constraint is changed in some way, the analyst should check downstream to see if the increase in volume is creating new bottlenecks.

A related hazard with using constrained demands in planning analyses is that unanticipated improvements in the coming years might release one or more constraints that were presumed to be in place for the planning analysis.

### 8. Generating Turning-Movement Volume Estimates from Link Volumes

The HCM's intersection analysis methods require turning-movement volumes. However, this information may not be available for planning and preliminary engineering analyses (e.g., when only link volume data are available, or when the turning movements produced by a transportation planning model are not considered to be reliable). In these cases, the following methods for estimating turning movements can be applied, originally documented in *NCHRP Report 255* (Pedersen and Samdahl 1982) and updated in *NCHRP Report 765* (CDM Smith et al. 2014). The analyst will need to manually check the results of these methods for reasonableness.

Procedures for estimating turning movements from travel model link volumes or intersection approach volumes are:

- Factoring procedures
  - Ratio method
  - Difference method
- Iterative procedures
  - Directional method
  - Non-directional method
- “T” intersection procedures
  - Directional method
  - Non-directional method

#### Factoring Procedures

Factoring procedures are used to estimate future turning movements based on the relationship between existing or base-year intersection turning-movement counts and base-year turning-movement assignments from a travel model. They require an accurate turning-movement count as a starting point. The assumption is that future-year turning movements will be similar to existing turning movements. Future-year turning movements can be predicted by comparing either relative ratios or differences between base-year and future-year travel model assignments.

##### *Ratio Method*

The ratio method produces a future-year turning-movement estimate by applying the ratio of the future-year model assignment and the base-year model assignment to the existing or base-year count. The method form is given by Equation 6:

$$FF_{Ti} = BC_i \times \left( \frac{FA_i}{BA_i} \right) \quad \text{Equation 6}$$

where

$FF_{ri}$  = future-year forecast volume for turning-movement  $i$  (veh/h),

$BC_i$  = base-year count for turning-movement  $i$  (veh/h),

$FA_i$  = future-year model assignment for turning-movement  $i$  (veh/h), and

$BA_i$  = base-year model assignment for turning-movement  $i$  (veh/h).

Turning-movement estimates or forecasts are computed individually and then summed to obtain approach volumes. Data needed to perform the procedure are the following:

- Base-year intersection turning-movement counts,
- Base-year traffic model turning-movement assignments, and
- Future-year traffic model turning-movement assignments.

In the following example, the count for a particular turning movement is 200 veh/h, the base-year travel model assignment for this movement is 260 veh/h, and the future-year travel model assignment is 500 veh/h. Applying the procedure yields the following future-year turning-movement forecast:

$$FF_{ri} = BC_i \times \left( \frac{FA_i}{BA_i} \right) = 200 \times \frac{500}{260} = 385 \text{ veh/h}$$

### *Difference Method*

The difference method produces a future-year turning-movement estimate by applying the relative difference between the base-year and future-year travel model assignment to the existing or base-year count. The method form is given by Equation 7:

$$FF_{di} = FA_i + (BC_i - BA_i) \tag{Equation 7}$$

where

$FF_{di}$  = future-year forecast volume for turning-movement  $i$  (veh/h),

$BC_i$  = base-year count for turning-movement  $i$  (veh/h),

$FA_i$  = future-year model assignment for turning-movement  $i$  (veh/h), and

$BA_i$  = base-year model assignment for turning-movement  $i$  (veh/h).

Turning-movement estimates or forecasts are computed individually and then summed to obtain approach volumes. Data needed to perform the procedure are the following:

- Base-year intersection turning-movement counts,
- Base-year traffic model turning-movement assignments, and
- Future-year traffic model turning-movement assignments.

Returning to the data from the previous example, where the count is 200 veh/h, the base-year travel model assignment for this movement is 260 veh/h, and the future-year travel model assignment is 500 veh/h, the future-year turning-movement forecast is computed as:

$$FF_{di} = FA_i + (BC_i - BA_i) = 500 + (200 - 260) = 440 \text{ veh/h}$$

### *Comparing the Results*

The ratio method produces a future turning-movement estimate of 385 veh/h, while the difference method, using the same data, produces an estimate of 440 veh/h. *NCHRP Report 255* (Pedersen and Samdahl 1982) recommends averaging the two to reduce the extremes, but averaging is not advised in *NCHRP Report 765* (CDM Smith et al. 2014). The belief is that averaging



will reduce the accuracy of one method or the other. Instead, advice is given that the analyst should evaluate the results from each method within the context of existing traffic volumes and turning-movement forecasts and then select a preferred method.

A fundamental assumption of both methods is that future turning movements will be of similar nature to existing turning movements. This assumption can be applied to land use, general development patterns, and resulting traffic patterns within the study area.

## Iterative Procedures

Iterative procedures are applied to produce either directional or non-directional (two-way) turning volumes; the typical application of this Guide will utilize directional turning movements. Iterative procedures are useful when it is important to preserve link entry and departure volumes. They require an initial estimate of turning percentages. Existing turning-movement counts are often used as the initial input, but an estimate of turning proportions can be used as well. Iterative procedures can use approach and departure link volumes directly, or they can be estimated by applying  $K$ - and  $D$ -factors to AADT or design-hour volumes.

### Directional Method

The directional method uses the initial estimate of turning movements, then alternatively balances approach (inflow) and departure (outflow) volumes in a turning-movement matrix until an acceptable level of convergence is reached. The future-year link volumes are fixed and the turning movements in the trip matrix are adjusted until they match the link volumes. The number of iterations required depends on the desired level of convergence and the difference between existing and future link volumes. Where large differences in link volumes occur (in an area where high growth is predicted, for example), several iterations may be required. Volumes normally converge within 6 to 10 iterations using this method.

The directional method consists of five steps, as described in *NCHRP Report 765* [CDM Smith et al. (2014) on pages 116–122]. The following notation is used:

- $n$  = number of intersection legs,
- $b$  = base-year,
- $f$  = future-year,
- $O$  = inflows (“from origin”),
- $D$  = outflows (“to destination”),
- $i$  = inflow (origin) link number,
- $j$  = outflow (destination) link number,
- $T$  = traffic volume,
- $P$  = estimated percentage of traffic flow (expressed in decimal form), and
- $*$  = adjusted value in each iteration.

The notation is combined to define the elements used in the method:

- $O_{ib}$  = base-year inflow to the intersection on link  $i$ ,
- $O_{if}$  = future-year inflow to the intersection on link  $i$ ,
- $D_{jb}$  = base-year outflow from the intersection on link  $j$ ,
- $D_{jf}$  = future-year outflow from the intersection on link  $j$ ,
- $T_{ijb}$  = base-year traffic flow entering through link  $i$  and departing through link  $j$ ,
- $T_{ijf}$  = future-year traffic flow entering through link  $i$  and departing through link  $j$ , and
- $P_{ijf}$  = future-year estimated turning-movement percentage (expressed in decimal form) of traffic flow entering through link  $i$  and departing through link  $j$ .

These elements are illustrated in Exhibit 10.

**Exhibit 10. Iterative method elements.**

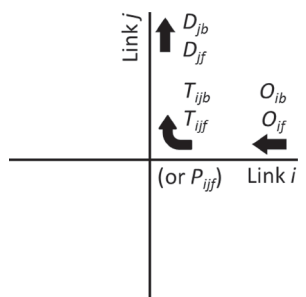

Source: *NCHRP Report 765* (CDM Smith et al. 2014), Figure 6-3.

**Exhibit 11. Turning-movement matrix structure.**

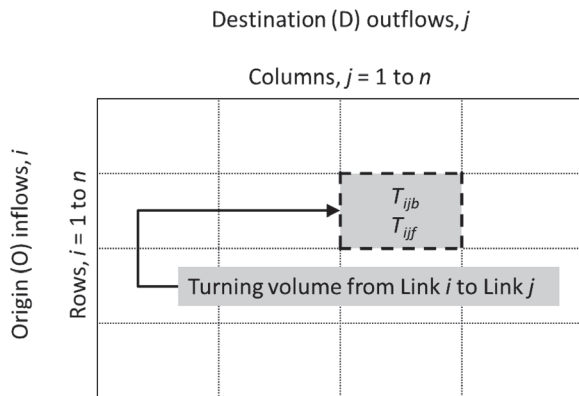

Source: NCHRP Report 765 (CDM Smith et al. 2014), Figure 6-4.

**Step 1: Turning-Movement Matrix Construction.** The first step in the process is to construct a turning-movement matrix. This is a square matrix, with one row and one column for each intersection leg, as shown in Exhibit 11. The inflows (approach volumes) are arranged in matrix rows and the outflows (departure volumes) are arranged in matrix columns. Each matrix cell represents the corresponding turning-movement “from link  $i$  to link  $j$ .” Unless U-turns are allowed, diagonal cells ( $i = j$ ) always will be zero.

An illustrative example of the intersection turning movements and corresponding matrix is shown in Exhibit 12. This example applies when base-year turning movements are known. When unknown, percentages are substituted for actual turning volumes and the corresponding matrix values are shown as a proportion. When percentages are used, all row totals of  $P_{ijf}$  must equal 1.0. Column totals will not equal 1.00 except by coincidence, but the sum of all columns (and the sum of all rows) should equal the total number of intersection legs. For example, for a four-legged intersection,  $\sum P_{rows} = \sum P_{columns} = 4 \times 1.00 = 4.00$ .

If initial turning movements are unknown, the turning volume movement matrix cells are populated by multiplying future link inflows ( $O_{ij}$ ) by the corresponding turning-movement percentage ( $P_{ijf}$ ), as shown in Equation 8:

$$T_{ijf}^* = O_{if} \times P_{ijf} \tag{Equation 8}$$

where all variables are as defined previously.

**Exhibit 12. Turning-movement matrix structure.**

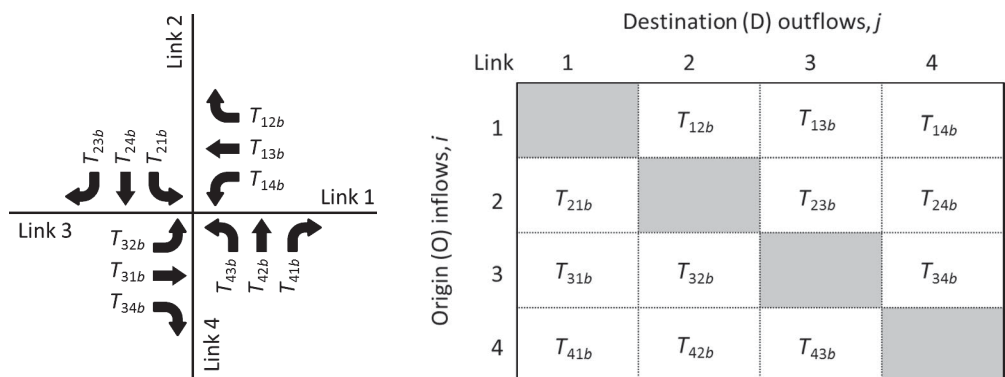

Source: NCHRP Report 765 (CDM Smith et al. 2014), Figure 6-5.

Exhibit 13 shows an example turning-movement matrix after the first step has been completed.

**Step 2: Perform First Row Iteration.** In the second step, base-year inflows  $O_{ib}$  are replaced with future-year inflows  $O_{if}$ . Each matrix cell is adjusted according to Equation 9:

$$T_{ijf}^* = \frac{O_{if}}{O_{ib}} T_{ijb} \tag{Equation 9}$$

where  $T_{ijf}^*$  is the adjusted future turning volume for this iteration.

A new matrix is constructed containing the future-year origin inflows (rows)  $O_{if}$ . New destination outflows (columns)  $D_{jf}^*$  are created by summing the adjusted turning movements  $T_{ijf}^*$  in each column  $j$ , as indicated by Equation 10:

$$D_{jf}^* = \sum_{i=1}^n T_{ijf}^* \tag{Equation 10}$$

Column totals  $D_{jf}^*$  from the adjusted turning-movement matrix are compared with the original column totals  $D_{jf}$  from the first step. If the difference between them is acceptable, then the method is complete and no further iterations are necessary. For most applications, a difference of  $\pm 10\%$  is acceptable. If the difference is greater than the desired limit, then further iterations are required.

**Step 3: Perform First Column Iteration.** In the third step, turning movements from the previous stage are adjusted further. The previous matrix is used, but the adjusted outflows  $D_{jf}^*$  are replaced with the original outflows  $D_{jf}$  (i.e., the outflow forecasts). Individual turning movements then are adjusted by the ratio of the original outflow forecasts to adjusted outflows as given by Equation 11:

$$T_{ijf,new} = \frac{D_{jf}}{D_{jf}^*} T_{ijf,old} \tag{Equation 11}$$

where

- $T_{ijf,old} = T_{ijf}^*$  matrix value from the previous step, and
- $T_{ijf,new} =$  Adjusted turning-movement matrix value  $T_{ijf}$  after this column iteration.

**Exhibit 13. Example turning-movement matrix and future link volumes.**

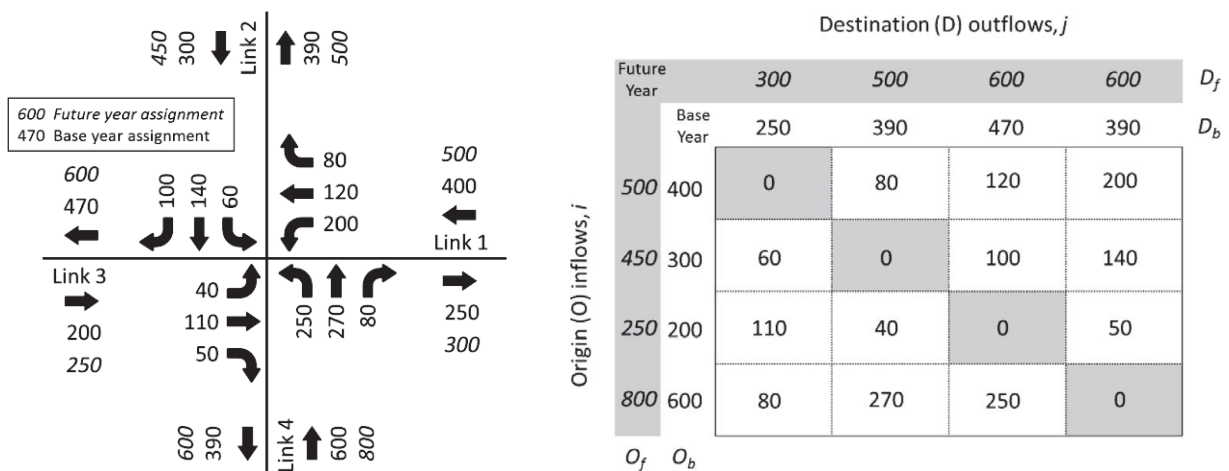

Source: NCHRP Report 765 (CDM Smith et al. 2014), Figure 6-6.

Should subsequent iterations be necessary, values of  $T_{ijf, \text{new}}$  created in this step become  $T_{ijf, \text{old}}$  in the next step.

A new matrix of adjusted turning movements  $T_{ijf, \text{new}}$  and future destination outflows (columns)  $D_{jf}$  is created. Adjusted row totals  $O_{if}^*$  are computed by summing  $T_{ijf, \text{new}}^*$  in each row, as shown in Equation 12:

$$O_{if}^* = \sum_{j=1}^n T_{ijf, \text{new}}^* \quad \text{Equation 12}$$

Similar to the previous step, adjusted row totals  $O_{if}^*$  are compared with original inflows  $O_{if}$ . If the difference between these two totals is acceptable using the same convergence criterion, then the method is done. If the discrepancy is greater, then further iterations will be necessary.

**Step 4: Repeat Row Iteration and Step 5: Repeat Column Iteration.** The fourth and fifth steps involve repeating the procedure. For row iterations (Step 2), new values for  $T_{ijf, \text{new}}^*$  are calculated, then  $D_{jf}^*$  is compared with  $D_{jf}$ . For column iterations, new values for  $T_{ijf, \text{new}}^*$  and  $O_{if}^*$  are computed, then  $O_{if}^*$  is compared with  $O_{if}$ .

Row and column iterations should be continued until acceptable differences between  $D_{jf}^*$  and  $D_{jf}$  and  $O_{if}^*$  and  $O_{if}$  are obtained. When those differences are deemed acceptable, values in the final matrix will be the estimated turning volumes.

Detailed documentation of the iterative directional method, including step-by-step iterations of an example, is provided in *NCHRP Report 765* (CDM Smith et al. 2014) and also in *NCHRP Report 255* (Pedersen and Samdahl 1982).

### *Non-Directional Method*

The non-directional method is intended for general planning purposes where non-directional (i.e., two-way) turning movements are desired. As HCM methods rely on directional volumes as inputs, this method is not applicable within the context of this Guide. The iterative non-directional method is fully documented in *NCHRP Report 765* (CDM Smith et al. 2014) and also in *NCHRP Report 255* (Pedersen and Samdahl 1982).

## **“T” Intersection Procedures**

Turning-movement estimates at three-legged or “T” intersections can be developed using simpler procedures than for four-legged-intersections.

### *Directional Method*

The directional method uses basic mathematical relationships among link volumes for estimating turning movements. To apply the method, one of the turning movements must be known or estimated, along with the approach and departure volumes for all three legs. If only two-way AADT volumes are known, hourly approach volumes can be estimated using appropriate *K*- and *D*-factors.

The directional method configuration and notation are shown in Exhibit 14. There are six potential scenarios where one of the turning movements is known or estimated. The computations for each scenario are shown in Exhibit 15.

**Exhibit 14. Directional method configuration and notation.**

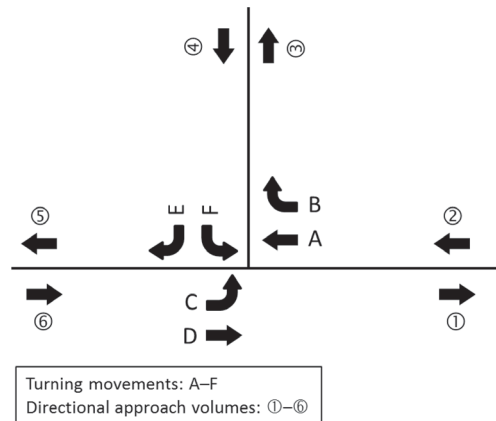

Source: *NCHRP Report 765* (CDM Smith et al. 2014), Figure 6-21.

**Exhibit 15. "T" intersection directional turning-movement computations.**

Known or Estimated Turning Volumes							
		A	B	C	D	E	F
Computed Turning Volumes	A		②-B	⑤-E	②-B	②-B	⑤-E
	B	②-A		②-A	③-C	③-C	②-A
	C	③-B	⑥-D		⑥-D	⑥-D	③-B
	D	⑥-C	①-F	⑥-C		①-F	⑥-C
	E	④-F	⑤-A	④-F	⑤-A		④-F
	F	①-D	④-E	①-D	④-E	④-E	

Source: *NCHRP Report 765* (CDM Smith et al. 2014), Table 6-6.

**Non-Directional Method**

The non-directional method is intended for general planning purposes where non-directional (i.e., two-way) turning movements are desired. As HCM methods rely on directional volumes as inputs, this method is not applicable within the context of the Guide. The iterative non-directional method is fully documented in *NCHRP Report 765* (CDM Smith et al. 2014) and *NCHRP Report 255* (Pedersen and Samdahl 1982).

Spreadsheet demonstrations of the methods for estimating turning movements from link volumes are included on the CD bound into *NCHRP Report 765*; an image file of the CD, which can be used to burn a CD containing the spreadsheets, is available at <http://www.trb.org/Publications/Blurbs/170900.aspx>.

**Florida DOT Method**

The Florida DOT uses a method originally described by Hauer et al. (1981). An initial estimate of the proportion of an approach's traffic turning right, turning left, or continuing straight can be provided by the user (for example, from existing turning movements), or the method can

create its own first-guess proportions from the approach volumes. Once the turning proportions have been specified, the method goes through a series of iterations, similar to the previously described iterative directional method, to develop the turning-movement estimates. As with the iterative method, the Florida DOT method is useful when it is desirable to preserve the link entry and exit volumes in the analysis. FDOT has developed the “TURNS5” spreadsheet ([http://teachamerica.com/tih/PDF/turns5-V02\\_XML.xls](http://teachamerica.com/tih/PDF/turns5-V02_XML.xls)) to assist analysts with implementing this method (Florida DOT 2014).

## 9. References

- American Association of State Highway and Transportation Officials. *AASHTO Guidelines for Traffic Data Programs*. Washington, D.C., 2009.
- CDM Smith, A. Horowitz, T. Creasey, R. Pendyala, and M. Chen. *NCHRP Report 765: Analytical Travel Forecasting Approaches for Project-Level Planning and Design*. Transportation Research Board of the National Academies, Washington, D.C., 2014.
- Dowling, R., A. Skabardonis, and V. Alexiadis. *Traffic Analysis Toolbox Volume III: Guidelines for Applying Traffic Microsimulation Modeling Software*. Report FHWA-HRT-04-040. Federal Highway Administration, Washington, D.C., June 2004.
- Dykstra, L., D. McLeod, and A. Piszczatoski. Standard K-Factors for Transportation Planning and Design. *ITE Journal*, Vol. 81, No. 11, Nov. 2011, pp. 20–25.
- Florida Department of Transportation. *Project Traffic Forecasting Handbook*. Tallahassee, 2014.
- Florida Department of Transportation. *2013 Quality/Level of Service Handbook*. Tallahassee, 2013.
- Hauer, E., E. Pagitsas, and B. T. Shin. Estimation of Turning Flows from Automatic Counts. In *Transportation Research Record 795*, Transportation Research Board, National Research Council, Washington, D.C., 1981, pp. 1–7.
- Highway Capacity Manual: A Guide to Multimodal Mobility Analysis*. 6th ed. Transportation Research Board, Washington, D.C., 2016.
- Pedersen, N. J., and D. R. Samdahl. *NCHRP Report 255: Highway Traffic Data for Urbanized Area Project Planning and Design*. Transportation Research Board, National Research Council, Washington, D.C., Dec. 1982.
- Pedutó, F., G. Cioffi, and R. Albertin. *Documentation of Selected Programs of the NYSDOT's Simulation System*. New York Department of Transportation, Albany, June 1977.
- Washington State Department of Transportation. *Peak Hour Report: Year 2007*. Transportation Data Office, Olympia, 2008.
- Zegeer, J. D., M. A. Vandehey, M. Blogg, K. Nguyen, and M. Ereti. *NCHRP Report 599: Default Values for Highway Capacity and Level of Service Analyses*. Transportation Research Board of the National Academies, Washington, D.C., 2008.



## E. Predicting Intersection Traffic Control

### 1. Overview

Analyzing the operation of an urban street using the HCM requires some knowledge of the type of traffic control used at the intersections along the street. When analyzing future conditions as part of a planning or preliminary engineering analysis, decisions may not have been made about the type of traffic control used at an intersection, or the purpose of the analysis may be to determine the type of traffic control that would likely be needed in the future under a particular analysis scenario. This section provides guidance on forecasting which type of traffic control may be needed at an intersection in the future, for use in preparing inputs to an HCM planning analysis.

The analyst should be aware that state and local policies may often specify the conditions under which particular types of intersection traffic control should or should not be considered. These policies supersede the guidance presented in this section.



### 2. Manual on Uniform Traffic Control Devices

FHWA's *Manual on Uniform Traffic Control Devices* (MUTCD 2009) provides warrants and criteria to help determine whether a traffic signal or all-way stop control may be justified at an intersection. Meeting one or more warrants does not automatically mean a particular type of traffic control is justified, but not meeting the warrants generally means that type of traffic control would not be justified. State supplements to the MUTCD, or state or local policies, may specify that certain warrants found in the MUTCD should not be used, and planning studies should respect those policies.

#### Determining 8th- and 4th-Highest Hour Volumes

The most commonly applied MUTCD warrants require the analyst to determine the 8th- or 4th-highest hour traffic volumes. The decision to install a traffic signal would normally be based on actual traffic counts, but when a planning or preliminary engineering analysis is being performed, future volumes are being estimated and typically exist only in the form of AADTs or peak hour volumes. Therefore, some other means is required to estimate what the 8th- or 4th-highest volume would be. Possible methods for doing so include the following, in order of preference:

- Calculate the ratio of 8th- (or 4th-) highest hour traffic volumes to peak hour traffic volumes using recent traffic counts from the intersection or a similar intersection.
- Calculate the ratio of 8th- (or 4th-) highest hour traffic volumes to peak hour traffic volumes using data from a permanent traffic recorder in the area.

- Apply a factor to the peak hour traffic volume. The specific factor will depend on how peaked the peak hour is. For example, when peak hour traffic represents 7.8% of AADT, the 4th-highest hour volume is approximately 90% of the peak hour volume, while the 8th-highest hour is approximately 80% of the peak hour volume (May 1990). On the other hand, when peak hour traffic represents 10.6% of AADT, the 4th-highest hour volume is approximately 67% of the peak hour volume, and the 8th-highest hour volume is approximately 55% of the peak hour volume (ITE 1982). In both cases, the 4th-highest volume represents approximately 7% of AADT, while the 8th-highest volume represents approximately 6% of AADT.

### Applying MUTCD Warrants

The basic information needed to apply the MUTCD warrants is listed in Exhibit 16.

Once the required data are available, the appropriate sections of the MUTCD are consulted to determine whether the traffic volumes would satisfy one or more warrants, given the other conditions (e.g., number of lanes, major street speed) existing at the intersection. These are:

- Section 4C.02 for the 8-hour traffic signal warrant,
- Section 4C.03 for the 4-hour traffic signal warrant, and
- Section 2B.07 for the all-way stop control criteria.

### 3. Graphical Method

As an alternative to evaluating the MUTCD traffic signal warrants, graphical methods can be used to predict the future intersection traffic control for use in a planning analysis. (MUTCD warrants, supplemented with state or local practice and engineering judgment, should always be used in making final decisions about intersection traffic control.) Graphical methods have the advantage of requiring fewer data than a signal warrant evaluation does, but have the disadvantage of employing built-in assumptions that may not be appropriate for a given location.

Exhibit 17 can be used to determine the likely future intersection traffic control, using only peak hour two-directional volumes for the major and minor streets and the directional distribution of volumes (50/50 or 67/33) as inputs. The signal warrant incorporated in the exhibit is the basic MUTCD eight-hour minimum hourly volume warrant for locations with populations of 10,000 or greater, major street speeds of 40 mph or less, and single-lane approaches. If other

**Exhibit 16. Required data for MUTCD warrant analysis.**

<b>8th-highest vehicular volume by approach (veh/h)</b>	•		•	6% of AADT
<b>Number of lanes on major street approach</b>	•	•		Must be provided
<b>Number of lanes on minor street approach</b>	•	•		Must be provided
<b>Major street speed (mph)</b>	•	•	•	Posted speed
<b>City population &lt; 10,000 (yes/no)</b>	•	•	•	Must be provided
<b>4th-highest vehicular volume by approach (veh/h)</b>		•		7% of AADT
<b>Peak hour minor street delay (s/veh)</b>			•	Must be provided; see Section N5 for guidance

Notes: See MUTCD Section 4C for definitions of the required input data and additional guidance.  
 8HR = 8-hour signal warrant, 4HR = 4-hour signal warrant, AWS = all-way stop warrant.



**Exhibit 17. Intersection control type by peak hour volume.**

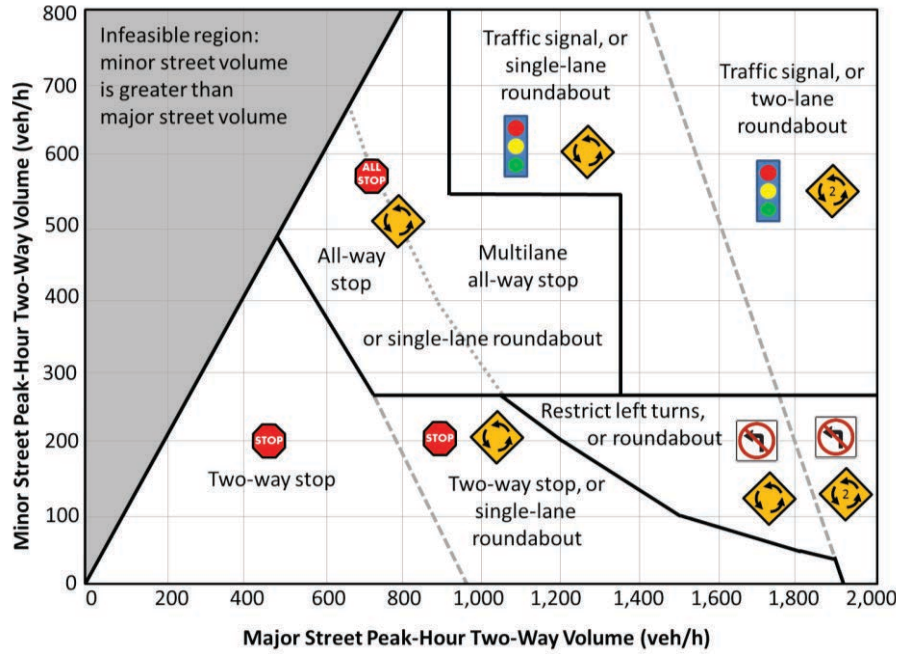

(a) 50/50 Volume Distribution on Each Street

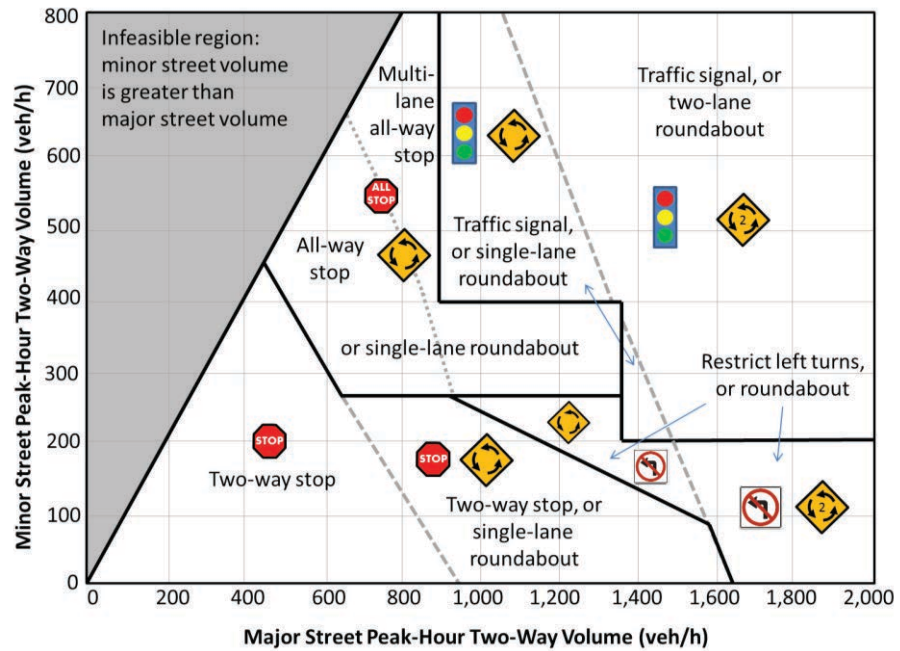

(b) 67/33 Volume Distribution on Each Street

Source: Calculated from MUTCD 8-hour signal warrant, MUTCD all-way STOP warrant, and HCM methods for roundabout capacity and STOP-controlled intersection delay.

Notes: Assumes eighth-highest-hour volumes = 55% of peak hour volumes, peak hour factor = 0.92, 10% left turns and 10% right turns on each approach, and a single lane on each approach as the base case. See text for an explanation of how boundaries between regions in the graphs were determined.

warrants or conditions are desired to be evaluated, then the MUTCD method described in Section E2 should be used instead.

As indicated in Exhibit 17, a roundabout is a potential option in many cases, in lieu of stop or traffic signal control. In deciding which option to use in the analysis, the analyst should consider local policies favoring or disfavoring roundabouts, as well as potential right-of-way or other constraints at the location. Chapter 3 of *NCHRP Report 672* (Rodegerdts et al. 2010) provides planning-level considerations for making choices between roundabouts and other forms of intersection control.

The upper boundary for two-way stop control in these graphs occurs when all-way stop warrants are met or when demand on the higher-volume minor street approach exceeds its capacity, whichever comes first. The lower boundary for a single-lane roundabout is set at the LOS C/D threshold of 25 seconds of average delay per vehicle for the higher-volume minor street approach; the upper boundary is set at 85% of the capacity of an entry to a single-lane roundabout. The boundary between single-lane and multilane all-way stop control is set at the HCM's LOS E/F threshold for a single-lane all-way stop intersection (HCM 2016).

The lower-right portion of the graphs includes the label "restrict left turns." In this region, major street volumes may be too high to provide sufficient capacity for side-street left turns, but side-street volumes are too low to meet all-way stop or traffic signal warrants. In this case, the side street might need to be restricted to right turns out only. (This region of the graphs may also indicate the need for access management measures for minor streets and driveways along an extended length of the major street.)

## 4. References

- Highway Capacity Manual: A Guide to Multimodal Mobility Analysis*. 6th ed. Transportation Research Board, Washington, D.C., 2016.
- Institute of Transportation Engineers. *Traffic and Transportation Engineering Handbook*. Washington, D.C., 1982.
- Manual on Uniform Traffic Control Devices. Federal Highway Administration, Washington, D.C., 2009.
- May, A. *Traffic Flow Fundamentals*. Prentice Hall Publishing, Englewood Cliffs, N.J., 1990.
- Rodegerdts, L., J. Bansen, C. Tiesler, J. Knudsen, E. Myers, M. Johnson, M. Moule, B. Persaud, C. Lyon, S. Hallmark, H. Isenbrands, R. B. Crown, B. Guichet, and A. O'Brien. *NCHRP Report 672: Roundabouts: An Informational Guide*. 2nd ed. Transportation Research Board of the National Academies, Washington, D.C., 2010.



## F. Default Values to Reduce Data Needs

### 1. Overview

Many HCM computational methods require a number of input parameters. For a detailed operations analysis, this can be an advantage, as the performance measure output by the method reflects many different factors that can influence the result. However, for planning and preliminary engineering analyses, the number of inputs can pose a challenge. The desired information may not yet be known, the level of effort required to gather the data may be out of proportion to the aims of the analysis, or a combination of these and other considerations can make it difficult to supply a particular input value.

One solution to applying HCM methods to planning and preliminary engineering analyses is to substitute *default values* for those inputs that cannot be measured directly. Using default values instead of field-measured values may introduce some error into the analysis results, but other data used for planning analyses (particularly forecast demand volumes) may have much greater uncertainties associated with their values and, consequently, much greater impact on the results. Furthermore, the goal of these types of analyses is not to make final decisions about roadway design and control elements, but rather to identify potential problems or to screen large numbers of alternatives; in these cases, precise results are neither required nor expected.

It is important to recognize that HCM input data have a hierarchy that varies according to the context of the planning and preliminary engineering application: There are applications where certain input data can be and must be measured. (These data are identified as “required inputs” in subsequent sections.) There are planning and preliminary engineering applications where certain input data can and should be estimated sensibly based on local and planned conditions; Section F4 addresses this situation. Finally, as discussed in Section F2, there are applications where certain data need not be measured and a general default value can be used instead. Parts 2 and 3 of the Guide provide simple default values for analysis situations where the analyst has deemed a locally measured value is not necessary.

This section provides guidance on applying default values to HCM methods and on developing local default values to use in place of the HCM’s national defaults.

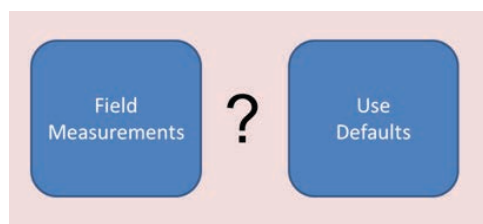

### 2. When to Consider Default Values

The decision to use a default value in place of a field-measured value should consider a number of factors, including:

- **The intended use of the analysis results.** In general, the less precisely that analysis results will be presented (e.g., under, near, or over capacity versus a particular LOS versus a specific travel speed estimate), the more amenable the analysis is to using default values, or tools based

on default values, such as service volume tables. Similarly, the farther away a final decision is (e.g., identifying potential problem areas for further analysis versus evaluating a set of alternatives versus making specific design decisions), the less potential exists for incorrect decisions to be drawn from the analysis results due to the use of a default value.

- **The scale of the analysis.** The larger the geographic scale of the analysis (i.e., the greater the number of locations that need to be analyzed), the greater the need to use default values due to the impracticality of collecting detailed data for so many locations.
- **The analysis year.** The farther out into the future that conditions are being forecast, the more likely that information will not be known with certainty (or at all), and the greater the need to apply default values.
- **The sensitivity of the analysis results to a particular input value.** Sections H through O of this Guide provide information about the sensitivity of analysis results to the inputs used by a given HCM operations method. Input parameters are characterized as having a low, moderate, or high degree of sensitivity, depending on whether a method's output changes by less than 10%, 10% to 20%, or more than 20%, respectively, when an input is varied over its reasonable range. The lower the result's sensitivity to a particular input, the more amenable that input is to being defaulted.
- **Ease of obtaining field or design data.** According to the HCM (2016), input parameters that are readily available to the analyst (e.g., facility type, area type, terrain type, facility length) should use actual values and not be defaulted.
- **Inputs essential to an analysis.** A few inputs to HCM methods, such as demand volumes and number of lanes, are characterized as "required inputs" and should not be defaulted. When the purpose of the analysis is to determine a specific value for a required input (e.g., the maximum volume for a given LOS), the HCM method is run iteratively, testing different values of the input until the desired condition is met.
- **Local policy.** State and local transportation agencies' traffic analysis guidelines may specify that particular inputs to HCM methods can or should not be defaulted.

### 3. Sources of Default Values

Once a decision has been made to use a default value for a particular methodological input, there are several potential sources for obtaining a default value. These are, in descending order of desirability according to the HCM (2000):

- **Measure a similar facility in the area.** This option is most applicable when facilities that have not yet been built are being analyzed and the scope of the analysis does not require measuring a large number of facilities.
- **Local policies and standards.** State and local transportation agencies' traffic forecasting guidelines may specify, or set limits on, default values to assume. Similarly, these agencies' roadway design standards will specify design values (e.g., lane widths) for new or upgraded roadways.
- **Local default values.** When available, local default values will tend to be closer to actual values than the HCM's national defaults. Heavy vehicle percentage, for example, has been shown to vary widely by state and facility type (Zegeer et al. 2008). The next subsection provides guidance on developing local default values.
- **HCM default values.** If none of the above options are feasible, then the HCM's national default values can be applied.

### 4. Developing Local Default Values

*This section is adapted from HCM (2016), Chapter 6, Appendix A.*

Local defaults provide input values for HCM methods that are typical of local conditions. They are developed by conducting field measurements in the geographic area where the values

will be applied, during the same time periods that will be used for analysis, typically weekday peak periods. For inputs related to traffic flow and demand, the peak 15-minute period is recommended as the basis for computing default values because this time period is most commonly used by the HCM's methodologies.

When an input parameter can significantly influence the analysis results, it is recommended that multiple default values be developed for different facility types, area types, or other factors as appropriate, as doing so can help reduce the range of observed values associated with a given default and thus the error inherent in applying the default. The *K*- and *D*-factors used to convert AADT volumes to directional analysis hour volumes are two such parameters. For urban streets, other sensitive parameters include peak hour factor, traffic signal density, and percent heavy vehicles. For freeways and highways, sensitive parameters include free-flow speed and peak hour factor.

## 5. References

- Highway Capacity Manual: A Guide to Multimodal Mobility Analysis*. 6th ed. Transportation Research Board, Washington, D.C., 2016.
- Highway Capacity Manual 2000*. Transportation Research Board, National Research Council, Washington, D.C., 2000.
- Zegeer, J. D., M. A. Vandehey, M. Blogg, K. Nguyen, and M. Ereti. *NCHRP Report 599: Default Values for Highway Capacity and Level of Service Analyses*. Transportation Research Board of the National Academies, Washington, D.C., 2008.



## G. Service Volume Tables to Reduce Analysis Effort

K-Factor	D-Factor	Four-Lane Freeways				Six-Lane Freeways			
		LOS B	LOS C	LOS D	LOS E	LOS B	LOS C	LOS D	LOS E
Level Terrain									
0.08	0.50	54.2	75.5	94.1	108.9	81.3	113.3	140.0	160.0
	0.55	49.3	68.7	85.5	99.0	73.9	103.0	128.0	144.0
	0.60	45.2	62.9	78.4	90.8	67.8	94.4	116.0	132.0
	0.65	41.7	58.1	72.4	83.8	62.6	87.2	108.0	124.0
0.09	0.50	48.2	67.1	83.6	96.8	72.3	100.7	124.0	140.0
	0.55	43.8	61.0	76.0	88.0	65.7	91.6	112.0	128.0
	0.60	40.2	56.0	69.7	80.7	60.2	83.9	104.0	120.0
	0.65	37.1	51.6	64.3	74.5	55.6	77.5	96.0	112.0
0.10	0.50	43.4	60.4	75.3	87.1	65.1	90.6	112.0	128.0
	0.55	39.4	54.9	68.4	79.2	59.1	82.4	104.0	120.0

### 1. Overview

One typical planning application of the HCM is to estimate the existing or future LOS of a large number of roadway links. For example, this activity might be performed as part of a screening evaluation (to identify links requiring more detailed analysis) or as part of an agency’s roadway system monitoring program. *Generalized service volume tables*, which estimate the maximum daily or hourly volume that a roadway can serve under an assumed set of conditions, can be useful tools for performing these types of evaluations. This section describes how service volume tables can be incorporated into a planning analysis to reduce the overall analysis effort.

### 2. Description

Service volume tables are look-up tables that estimate the maximum daily or hourly volume for a given LOS under a specific combination of conditions. For ease of use, generalized service volume tables require a minimum of user inputs—typically, key design parameters that have the greatest influence on a facility’s capacity and LOS, such as the number of lanes. Given these inputs, a user can then read the maximum volume (*service volume*) for a given LOS directly from the table and compare it with the actual or forecast volume for the facility. A volume greater than the service volume for the desired LOS indicates the need for further analysis (HCM 2016).

The area type (e.g., urban, rural) often serves as a proxy for many default values (for example, driver population, percentage heavy vehicles, peak hour factor). As such, the area type often has a significant effect on the service volumes.

It is unlikely that any given roadway’s characteristics will exactly match the default values used in creating the table. Therefore, conclusions drawn from the use of service volume tables should be considered to be, and presented as, rough approximations. In particular, generalized service volume tables should not be used to make final decisions about important roadway design features—this activity requires a full operational analysis. However, as long as the analyst recognizes and respects the limitations of this tool, generalized service volume tables can be a useful sketch-planning tool for developing quick estimates of LOS and capacity, especially for large numbers of facilities (HCM 2016).

### 3. When to Consider Service Volume Tables

The decision to use a service volume table should consider a number of factors, including:

- **The scale of the analysis.** The larger the geographic scale of the analysis (i.e., the greater the number of locations that need to be analyzed), the more applicable service volume tables become

due to the impracticality of collecting detailed data for so many locations. When a small number of locations is being analyzed, other analysis tools will likely provide more accurate results, as it becomes more feasible to collect data, apply less-generalized default values, or both. Nevertheless, service volume tables can be applied to smaller sets of locations when the outcome of the analysis does not require a higher level of accuracy.

- **The intended use of the analysis results.** Service volume tables are well-suited to analyses where the identification of a potential operational problem will lead to a follow-up, more detailed analysis using more accurate tools and input data. They are also well-suited to performance management applications involving LOS or capacity calculations (e.g., calculating the number of miles of state highway operating at LOS E or worse during peak periods). They are not suitable for making final decisions about roadway design or control elements, nor for making final assessments about the adequacy of a roadway to accommodate additional demand (such as might be done as part of a traffic impact study).
- **Availability of a suitable table.** The accuracy of the results from a generalized service volume table depends greatly on how well the default values used to generate the table match conditions on the roadway being analyzed. The next subsection discusses potential sources of service volume tables and their respective advantages and disadvantages. Assumptions common to any service volume table include: (1) uniform roadway cross-section, (2) uniform roadway demand, (3) no queue spillback (e.g., from a left-turn lane, from an off-ramp, from one freeway segment to another), and (4) traffic signal timing that adequately accommodates all turning movements (HCM 2016; Florida DOT 2013). The more that actual conditions vary from these assumptions, the less suitable a service volume table will be.
- **Local policy.** State and local transportation agencies' traffic analysis guidelines may specify that a particular service volume table should be used for particular types of analyses, or that service volume tables should not be used in particular circumstances.

The analyst should also be cautious when the estimated LOS is near or at LOS F. The actual operations of the intersection, segment, or facility fluctuate a great deal at the LOS E/F boundary. Consequently, service volume tables cannot be relied upon when approaching this boundary. More detailed analyses are required to better pinpoint the actual operations.

#### 4. Sources of Generalized Service Volume Tables

There are three main sources for generalized service volume tables, which are discussed in more detail in the remainder of this section:

1. The HCM's generalized service volume tables,
2. Florida DOT's generalized service volume tables, and
3. Local service volume tables.

##### HCM Generalized Service Volume Tables

The HCM (2016) provides generalized service volume tables for the following system elements:

- Basic freeway segments (Chapter 12, Exhibits 12-39 and 12-40),
- Multilane highways (Chapter 12, Exhibits 12-41 and 12-42),
- Two-lane highways (Chapter 15, Exhibit 15-46),
- Urban street facilities (Chapter 16, Exhibit 16-16), and
- Signalized intersections, as an illustration (Chapter 19, Exhibit 19-36).

The assumptions (e.g., default values) used to develop the tables are provided with each table and explained in the accompanying text in the HCM. The default values used to develop the tables are based on the HCM's national average values, which may be different from local conditions in the area being analyzed. In particular, the default values for percentage heavy vehicles, peak hour

factor, and free-flow speed are recommended to be compared to local conditions, if possible, when evaluating the suitability of the HCM tables for a particular analysis. For urban streets, through traffic  $g/C$  ratio (the percentage of time through traffic receives a green signal at a traffic light) and traffic signal spacing are additional parameters that are recommended to be compared to local conditions when possible.

Except for the signalized intersection table, all of the HCM's tables are daily tables (i.e., they present maximum AADTs for a given LOS) and the user must select appropriate  $K$ - (analysis hour) and  $D$ - (directional) factors that convert AADT to an analysis hour directional volume when applying the table. The signalized intersection table presents maximum hourly volumes for a given LOS; users can convert these to AADTs by applying  $K$ - and  $D$ -factors.

Other inputs required by the HCM tables are:

- Number of travel lanes,
- Terrain type (freeways and highways),
- Area type (freeways and multilane highways),
- Highway class (two-lane highways),
- Posted speed (urban streets), and
- $g/C$  ratio (signalized intersections).

### FDOT Generalized Service Volume Tables

The Florida DOT (FDOT) is one of the leading users of generalized service volume tables and has sponsored a considerable body of research related to them. FDOT's *Quality/Level of Service Handbook* (2013) describes the assumptions and methodological extensions used in developing the FDOT tables; the tables themselves also list the input values used to develop them.

The default values used by FDOT's tables are based on typical Florida values. In particular, the daily Florida tables apply default  $K$ - and  $D$ -factors for specific combinations of facility geometries (e.g., four-lane undivided arterials), ensuring consistent application of the tables across the state. As with the HCM tables, key default values that can significantly affect results should be compared to local conditions when possible. These include percentage heavy vehicles, peak hour factor, and free-flow speed; for urban streets, these also include through traffic  $g/C$  ratio, saturation flow rate, and traffic signal spacing. The FDOT tables assume level terrain.

Both daily and peak hour service volume tables are provided for the following facility types and travel modes:

- Signalized arterial streets,
- Freeways,
- Uninterrupted-flow highways (multilane and two-lane highways use the same table),
- Bicycles on urban streets,
- Pedestrians on urban streets, and
- Public transit buses on urban streets.

Input data required by these tables consist of:

- **Signalized arterials:** state or non-state roadway, number of lanes, posted speed, median type, presence of exclusive left- and right-turn lanes, and one- or two-way facility;
- **Freeways:** number of lanes, auxiliary lane presence, and ramp meter usage;
- **Uninterrupted-flow highways:** number of lanes, median type, presence of exclusive left-turn lanes, and (for two-lane highways only) passing lane percentage;
- **Bicycles:** percent of facility with a paved shoulder or bicycle lane (three categories corresponding to nearly all, more than half, less than half);



- **Pedestrians:** percent of facility with a sidewalk (same categories as for bicycles); and
- **Buses:** percent of facility with a sidewalk (two categories of “nearly all” and “all others”) and bus frequency.

Although FDOT uses the HCM as the starting point for the computations used to develop its tables, there are some important differences in the methodologies that mean that the FDOT tables will produce different results than a “pure” application of the HCM method. Key differences include:

- **Signalized arterials:** methodological extension for auxiliary lanes through intersections (i.e., extra through lanes on the approach and exit to an intersection), and use of arterial classes for determining LOS thresholds;
- **Freeways:** treatment of capacity reductions in interchange areas, maximum capacity values for different area types, and a methodological extension for ramp metering effects;
- **Uninterrupted-flow highways:** methodological extension for left-turn lane provision, and a different two-lane highway method than used by the HCM;
- **Bicycles and pedestrians:** slightly different computations than the HCM methods; and
- **Buses:** a method adapted from the *Transit Capacity and Quality of Service Manual (TCQSM)* 2nd Edition (Kittelson & Associates et al. 2003), while the HCM (2016) and the TCQSM 3rd Edition (Kittelson & Associates et al. 2013) use a different method that consider some of the same factors.

## Local Service Volume Tables

Developing local service volume tables is a way to address a key issue with applying service volume tables—namely, that the assumptions used to develop the tables may not necessarily match local conditions. In addition, local service volume tables can be developed that allow the user to vary other parameters than those used by the HCM or FDOT tables. The effort taken to develop local tables can pay off with the creation of an easy-to-apply set of service volume tables that produces reasonable results.

The HCM (2016) describes a method for developing local service volume tables in Appendix B of Chapter 6. The analyst needs to develop a default value for each input parameter used by the applicable HCM method. When the HCM method is particularly sensitive to a particular parameter, or when the range of local observed values varies greatly, a set of default values should be considered for that parameter. Section F of the Guide provides guidance on selecting appropriate default values. Once the default values are selected, the analyst uses a computational engine or HCM-implementing software to back-solve for the maximum volume associated with a particular LOS, using the analyst’s selected set of default values.

As an alternative, FDOT’s LOSPLAN planning software package provides table generators that build service volume tables from a set of user-specified input values (Florida DOT 2013). The user should be aware of the differences between the FDOT and HCM methods, highlighted above, before applying these service volume table generators.

## 5. References

- Florida Department of Transportation. *2013 Quality/Level of Service Handbook*. Tallahassee, 2013.
- Highway Capacity Manual: A Guide to Multimodal Mobility Analysis*. 6th ed. Transportation Research Board, Washington, D.C., 2016.
- Kittelson & Associates, Inc.; KFH Group, Inc.; Parsons Brinckerhoff Quade and Douglass, Inc.; and K. Hunter-Zaworski. *TCRP Report 100: Transit Capacity and Quality of Service Manual*, 2nd ed. Transportation Research Board of the National Academies, Washington, D.C., 2003.
- Kittelson & Associates, Inc.; Parsons Brinckerhoff; KFH Group, Inc.; Texas A&M Transportation Institute; and Arup. *TCRP Report 165: Transit Capacity and Quality of Service Manual*, 3rd ed. Transportation Research Board of the National Academies, Washington, D.C., 2013.



## PART 2

# Medium-Level Analysis Methods

The sections in Part 2 of the Guide describe medium-level analysis methods that work best when evaluating a single freeway, highway, or urban street facility and its component interchanges, segments, and intersections. The sections are organized according to the system elements (e.g., freeways, signalized intersections) used by the HCM, and include sections focusing on the analysis of non-automobile modes:

- H. Freeway analyses
- I. Multilane highways
- J. Two-lane highways
- K. Urban streets
- L. Signalized intersections
- M. STOP-controlled intersections
- N. Roundabouts
- O. Pedestrians, bicyclists, and public transit
- P. Truck level of service

Sections H–N have similar structures, to aid the reader in quickly finding information relevant to a particular analysis need. The typical contents of these sections include:

- System element definition and overview
- Potential applications for the methods presented in the section
- Summary of the types of methods presented in the section
- Scoping and screening method (e.g., using generalized service volume tables)
- Full HCM method with defaults
- Simplified version or versions of the full HCM method
- Travel time reliability estimation method (if available)
- Cross-references to multimodal performance measures provided in Sections O and P
- Cross-references to worked examples in the case studies in Part 4

Section O provides medium-level methods for estimating pedestrian, bicycle, and public transit performance measures and is organized by the system elements used in sections H–N. Section O also provides planning methods for off-street pedestrian and bicycle facilities. Section P describes a planning method for estimating truck LOS.



## H. Freeway Analyses

### 1. Overview

A freeway is a grade-separated highway with full control of access and two or more lanes in each direction dedicated to the exclusive use of motorized vehicles.

This section presents medium-level methods suitable for evaluating single freeway facilities or segments.

### 2. Applications

The methodologies presented in this section support the following planning and preliminary engineering applications:

- Development of a freeway corridor system management and improvement plan;
- Feasibility studies of:
  - Adding a high-occupancy vehicle (HOV), high-occupancy toll (HOT), or express lane (or converting an existing lane or shoulder lane to HOV, HOT, or toll operation);
  - Ramp metering; or
  - Managed lanes, including speed harmonization, temporary shoulder use, and other active transportation and demand management (ATDM) strategies;
- Interchange justification or modification studies (the freeway mainline portions of these studies); and
- Land development traffic impact studies.

The facility-specific procedures described here produce facility-specific performance results that can be aggregated into system performance measures for transportation systems plans. Section R, Areas and Systems, provides more cost-efficient methods for computing system performance measures.

HCM Chapter 25, Freeway Facilities: Supplemental, presents a model for predicting the performance of freeways with extended upgrades, significant volumes of trucks, or both (HCM 2016). This method is not addressed in this Guide and users should be cautious about using this section's planning methods to predict freeway performance for extended upgrades (i.e., upgrades of greater than 2% persisting for one mile or more).

The planning methods described in this section do not explicitly address freeway work zones, ATDM measures, and managed (e.g., toll) lanes. Further information on these topics can be found in HCM Chapter 10, Freeway Facilities Core Methodology.



### 3. Analysis Methods Overview

Freeway performance can be directly measured in the field or estimated in great detail using microsimulation. However, the resource requirements of these methods render them generally impractical for most planning and preliminary engineering applications.

The HCM provides a less resource-intensive approach to estimating freeway performance; however, it too is generally impractical to use for many planning and preliminary engineering analyses if 100 percent field-measured inputs are to be used.

This section presents two medium-level methods for evaluating freeway performance, plus a high-level screening and scoping method that can be used to focus the analysis on only those locations and time periods requiring investigation, as shown by the unshaded boxes in Exhibit 18.

The HCM’s segment and facility analysis methods, covered in HCM Chapters 10 to 14, provide a good basis for estimating freeway performance under many conditions. The basic segment analysis method is relatively simple to apply when defaults are used for some difficult-to-obtain inputs. Analysis of on-ramps and off-ramps (merge and diverge segments in HCM parlance) and weaving segments is a bit more challenging with a more complex set of equations, but the computational effort is simplified with software. The freeway facility method is the most challenging, requiring a great deal more data to cover the larger geographic area involved in a full facility analysis. In addition, several computations are iterative. Generally, specialized software is required to implement the HCM facility method.

Consequently, this section of the Guide presents a simplified HCM facility analysis method that reduces the overall number of computations and eliminates the dynamic segmentation and iterative computations. The simplified analysis method is designed to be easily programmable in a static spreadsheet without need for macros.

Because both the HCM method and the simplified method require a fair amount of data, this section also provides a high-level service volume and volume-to-capacity (v/c) ratio screening method for quickly identifying which portions of the freeway can be evaluated solely using the segment analysis methods and which portions will require a facility-level analysis to properly account for the spillover effects of congestion. The high-level method

**Exhibit 18. Analysis options for freeways.**

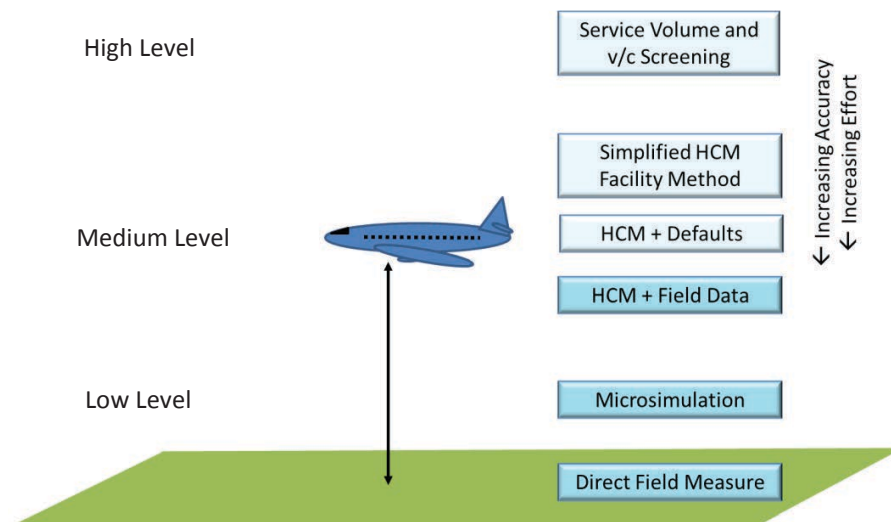

can also be used to quickly compare improvement alternatives according to the capacity they provide.

## 4. Scoping and Screening Method

### Generalized Service Volume Table

Whether or not a more detailed freeway facility analysis is needed can be determined by comparing the counted or forecasted peak hour or daily traffic volumes for the sections of the freeway between each on- and off-ramp to the values given in Exhibit 19. If all of the section volumes fall in the LOS E range or better, there will be no congestion spillover requiring a full facility analysis to better quantify the facility’s performance. One can then use the HCM segment analysis procedures with defaults for some of the inputs to evaluate the performance of each segment. (Note that “segments” have a special definition in the HCM, while “sections” are defined in this Guide by the freeway on- and off-ramps.)

The service volumes in Exhibit 19 can also be used to quickly determine the geographic and temporal extent of the freeway facility that will require analysis. If the counted or forecasted volumes for a section fall below the agency’s target LOS standard, then the section can be excluded from a more detailed analysis. If the volumes fall near or above the volume threshold for the agency’s target LOS, then the section may require more detailed analysis.

Any section that exceeds the capacity values in Exhibit 19 will have queuing that may impact upstream sections and reduce downstream demands. In such a situation, a full freeway facility analysis is required to ascertain the freeway’s performance. The facility analysis can be performed either using the HCM method with defaults, or the simplified HCM method, both of which are described later in this section.

The analyst may also use the capacities shown in Exhibit 19 to compute the peak hour, peak direction demand-to-capacity ratio for each segment under various improvement options. These options can then be quickly ranked according to their forecasted demand-to-capacity ratios for the critical sections of the freeway.

**Exhibit 19. Daily and peak hour service volume and capacity table for freeways.**

Area Type	Terrain	Peak Hour Peak Direction (veh/h/ln)			AADT (2-way veh/day/ln)		
		LOS A-C	LOS D	LOS E (capacity)	LOS A-C	LOS D	LOS E (capacity)
Urban	Level	1,550	1,890	2,150	14,400	17,500	19,900
Urban	Rolling	1,480	1,810	2,050	13,700	16,700	19,000
Rural	Level	1,460	1,770	2,010	12,100	14,800	16,800
Rural	Rolling	1,310	1,600	1,820	11,000	13,400	15,200

Source: Adapted from HCM (2016), Exhibit 12-39 and 12-40.

Notes: Entries are maximum vehicle volumes per lane that can be accommodated at stated LOS.

AADT = annual average daily traffic. AADT per lane is two-way AADT divided by the sum of lanes in both directions.

Urban area assumptions: Free-flow speed = 70 mph, 5% trucks, 0% buses, 0% RVs, peak hour factor = 0.94, 3 ramps/mi, 12-ft lanes, *K*-factor = 0.09, and *D*-factor = 0.60.

Rural area assumptions: Free-flow speed = 70 mph, 12% trucks, 0% buses, 0% RVs, peak hour factor = 0.94, 0.2 ramps/mi, capacity adjustment factor for driver population = 1.00, 12-ft lanes, 6-ft lateral clearance, *K*-factor = 0.10, and *D*-factor = 0.60.

Similar tables can be developed by adjusting input values to reflect other assumptions.

The *K*-factor is the ratio of weekday peak hour two-way traffic to AADT. The *D*-factor is the proportion of peak hour traffic in the peak direction.

### Estimating Freeway Service Volumes

The approximate maximum AADT (two-way) that can be accommodated by a freeway at a given LOS can be estimated from Exhibit 19. For example, an eight-lane freeway can carry between 120,000 (15,200 × 8 lanes) and 160,000 (19,900 × 8 lanes) AADT at LOS E, depending on its location (urban or rural) and the terrain type. Higher AADTs can be accommodated when the proportion of AADT occurring during the peak hour (i.e., *K*-factor) is lower, the proportion of traffic in the peak direction during the peak hour (i.e., *D*-factor) is lower, or both.

Single-lane managed lanes (e.g., HOV lanes, HOT lanes) have capacities between 1,500 and 1,800 vehicles per hour per lane (veh/h/ln) depending on the free-flow speed and the type of barrier or buffer (if any) separating the single managed lane from the other general purpose lanes. Dual managed lanes have capacities between 1,650 and 2,100 veh/h/ln (HCM 2016).

When local traffic data suggest that values different from the assumptions used in Exhibit 19 would be more appropriate, the analyst should modify the daily and hourly service volumes as follows:

$$DSV = DSV_0 \times \frac{f_{HV} \times CAF_p \times PHF}{K \times D} \times \frac{K_0 \times D_0}{f_{HV,0} \times CAF_{p,0} \times PHF_0} \tag{Equation 13}$$

where

- DSV* = daily service volume (veh/day/ln),
- DSV<sub>0</sub>* = initial daily service volume in Exhibit 19 (veh/day/ln),
- f<sub>HV</sub>*, *f<sub>HV,0</sub>* = desired and initial adjustment factors, respectively, for presence of heavy vehicles in the traffic stream,
- CAF<sub>p</sub>*, *CAF<sub>p,0</sub>* = desired and initial capacity adjustment factors, respectively, for unfamiliar driver populations,
- PHF*, *PHF<sub>0</sub>* = desired and initial peak hour factors, respectively,
- K*, *K<sub>0</sub>* = desired and initial proportions, respectively, of daily traffic occurring during the peak hour, and
- D*, *D<sub>0</sub>* = desired and initial proportions, respectively, of traffic in the peak direction during the peak hour.

Equation 13 can also be used to modify the peak hour, peak direction service volumes if the initial peak hour service volumes from Exhibit 19 are used instead of the daily values.

The heavy vehicle adjustment factor *f<sub>HV</sub>* used in the service volume table is computed using the following adaptation of HCM Equation 12-10 (HCM 2016):

$$f_{HV} = \frac{1}{1 + P_{HV} \times (E_{HV} - 1)} \tag{Equation 14}$$

where

- f<sub>HV</sub>* = heavy vehicle adjustment factor (decimal),
- P<sub>HV</sub>* = percentage heavy vehicles (decimal), and
- E<sub>HV</sub>* = heavy vehicle equivalence from Exhibit 20.

For convenience, all heavy vehicles are assigned a single passenger car equivalent (PCE) value from Exhibit 20 below.

Daily service volumes should be rounded down to the nearest hundred vehicles, given the many default values used in their computation. Peak hour, peak direction service volumes should be rounded down to the nearest ten vehicles.

**Exhibit 20. Heavy vehicle equivalence values for freeways.**

Terrain Type	<i>E<sub>HV</sub></i>
Level	2.0
Rolling	3.0
Mountainous	5.0

Source: Adapted and extrapolated from HCM (2016), Exhibit 12-25.

**Exhibit 21. Required data for HCM freeway analysis.**

Input Data (units)	Performance Measure						Default Value
	FFS	Cap	Spd	LOS	Que	Rel	
Lane widths and right side lateral clearance (ft)	•	•	•	•	•	•	12-ft lanes 10-ft lateral clearance
Ramp density (per mile)	•	•	•	•	•	•	Must be provided
Percentage heavy vehicles (%)		•	•	•	•	•	12% (rural), 5% (urban)
Terrain type/specific grade		•	•	•	•	•	Must be provided
Number of directional lanes		•	•	•	•	•	Must be provided
Peak hour factor (decimal)		•	•	•	•	•	0.94
Driver population factor (decimal)		•	•	•	•	•	1.00 (i.e., familiar drivers)
Segment length (mi)			•	•	•	•	Must be provided
Directional demand (veh/h)			•	•	•	•	Must be provided
Variability of demand						•	Must be provided
Incident and crash frequencies						•	Must be provided
Severe weather frequencies						•	Must be provided
Work zone frequencies						•	Must be provided

Notes: FFS = free-flow speed (mph), Cap = capacity (veh/h/ln), Spd = speed (mph), LOS = level of service (A–F), Que = queue (veh), and Rel = travel time reliability (several measures).

If a service volume table is used to determine LOS, the data requirements consist of AADT; *K*-factor (proportion of daily traffic occurring in the peak hour); *D*-factor (proportion of peak hour traffic in the peak direction); and number of lanes.

## 5. Employing the HCM with Defaults

The HCM divides the freeway facility into various uniform segments that may be analyzed to determine capacity and LOS. HCM Chapter 10, Freeway Facilities Core Methodology, provides more details on how each segment type is defined. Exhibit 21 lists the data needed to evaluate the full range of performance measures for freeway facility and segment analysis. Individual performance measures may require only a subset of these inputs.

Free-flow speed estimation using the HCM requires the following information about the facility’s geometry: lane widths, right side lateral clearance, and the number of ramps per mile.

Capacity (in terms of vehicles per hour) requires the free-flow speed plus additional data on heavy vehicles, terrain type, number of lanes, peak hour factor (the ratio of the average hourly flow to the peak 15-minute flow rate), and the driver population (i.e., familiar or unfamiliar drivers).

Once free-flow speed and capacity have been calculated, then speed, LOS, and queue lengths can be estimated if additional information about segment lengths and the directional demand (vehicles per hour) is available.

Travel time reliability analysis requires the same data required to estimate speeds plus information on the variability of demand; the severity, frequencies and durations of incidents; the frequency of severe weather conditions; and the frequencies of work zones by number of lanes closed by duration.

## 6. Simplified HCM Facility Method

The simplified HCM facility method for freeways focuses on facility-level analysis and section-level analysis. A section is defined as extending from ramp gore point to ramp gore point, avoiding the need to subdivide the section into 1,500-foot-long HCM merge and diverge areas. A section may combine several HCM segments. For example, a section extending between an

**Exhibit 22. Relationship of HCM segments to simplified method sections.**

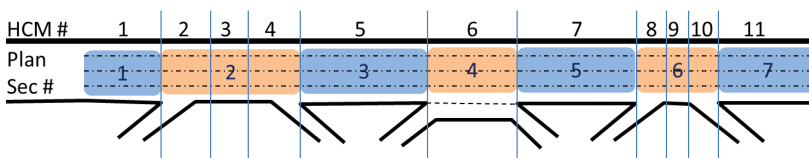

on-ramp and an off-ramp may be composed of three HCM segments: a merge segment, a basic or weave segment, and a diverge segment.

### Defining Sections for the Simplified Method

Input variables are characterized as global or section inputs. Planning analysis sections are defined to occur between points where either demand or capacity changes. For example, if a lane drop exists between an on- and off-ramp, that length will involve two sections (because the reduced number of lanes reduces the capacity of the section). But for a three-segment sequence of merge area, basic segment, and diverge area, the simplified method defines a single section. Significant grade changes (i.e., involving grades steeper than 2%) also should be considered for separate sections.

For example, the facility shown in Exhibit 22 with eleven HCM segments would be transformed into seven planning sections for use with the simplified method.

### Data Requirements

The data needs for the simplified freeway facility analysis method, shown Exhibit 23, are similar to those of the HCM method listed in Exhibit 21. The differences are that the simplified method uses posted speed limits to estimate the free-flow speed, and the travel time reliability analysis requires only the crash rate for the facility.

Global inputs include information about the facility of interest. Those are applied to all sections across all analysis periods. They include free-flow speed, peak hour factor, percentage heavy vehicles (%HV), *K*-factor, and a traffic growth factor (if used to obtain forecasts).

**Exhibit 23. Required data for simplified freeway facility analysis.**

Input Data (units)	Performance Measure						Default Value
	FFS	Cap	Spd	LOS	Que	Rel	
Posted speed limit (mph)	•	•	•	•	•	•	Must be provided
Percentage heavy vehicles (%)		•	•	•	•	•	12% (rural), 5% (urban)
Terrain type/specific grade		•	•	•	•	•	Must be provided
Number of directional lanes		•	•	•	•	•	Must be provided
Peak hour factor (decimal)		•	•	•	•	•	0.94
Driver population factor (decimal)		•	•	•	•	•	1.00
Segment length (mi)			•	•	•	•	Must be provided
Directional demand (veh/h)			•	•	•	•	Must be provided
Average crash rate						•	Must be provided

Notes: FFS = free-flow speed (mph), Cap = capacity (veh/h/ln), Spd = speed (mph), LOS = level of service (A–F), Que = queue (veh), and Rel = travel time reliability (several measures).

If a service volume table is used to determine LOS, the data requirements consist of AADT, *K*-factor (proportion of daily traffic occurring in the peak hour), *D*-factor (proportion of peak hour traffic in the peak direction), and number of lanes.



## Estimating Inputs

This subsection describes procedures for estimating the free-flow speed, the section type, and the section capacities.

### Identifying Freeway Section Types

The following definitions are used to split the freeway mainline into its component sections:

- A *basic freeway section* is a section of freeway with a constant demand and capacity, without the presence of on-ramps or off-ramps.
- A *freeway ramp section* is a section of freeway with an on-ramp, off-ramp, or both, but without the presence of an auxiliary lane connecting two ramps.
- A *freeway weaving section* occurs wherever an on-ramp is followed by an off-ramp, *and the two are connected by an auxiliary lane*.

### Estimating Free-Flow Speed

Free-flow speed is the average traffic speed under low-flow conditions. The most-accurate method for estimating segment free-flow speeds is to measure it in the field during low-flow conditions (under 800 veh/h/ln, after considering the effects of heavy vehicles and peaking within the peak hour). In urban environments, traffic sensors may be available to allow the estimation of free-flow speeds; however, this is not usually practical for planning applications. HCM Equation 12-2 (HCM 2016) can be used to estimate free-flow speeds based on the facility’s geometric characteristics:

$$FFS = 75.4 - f_{LW} - f_{RLC} - 3.22 \times TRD^{0.84} \quad \text{Equation 15}$$

where

$FFS$  = free-flow speed (mph),

$f_{LW}$  = adjustment for lane width (mph) = 0.0 for 12-ft or wider lanes, 1.9 for 11-ft lanes, or 6.6 for 10-ft lanes (see HCM Exhibit 12-20),

$f_{RLC}$  = adjustment for right side lateral clearance (mph), ranges from 0.0 for 6-ft lateral clearance to 3.0 for 1-ft clearance with 2 directional lanes (see HCM Exhibit 12-21), and

$TRD$  = total ramp density (ramps/mi) = number of on- and off-ramps in one direction for 3 miles upstream and 3 miles downstream, divided by 6 miles.

An alternative approach is to assume the free-flow speed is equal to the posted speed limit plus an adjustment reflecting local driving behavior. HCM Exhibit 10-7 (HCM 2016) suggests adding 5 mph to the posted speed limit.

All of these approaches for estimating free-flow speed assume all vehicles have the same posted speed limit. Should the posted speed limit for trucks or other vehicle classes be lower than that for other vehicle types, then the analyst will have to apply some judgment based on local experience when employing the above methods to estimate free-flow speed.

### Estimating Section Capacities

Free-flow speed and percent heavy vehicles are used to calculate section capacity using the following equation:

$$c_i = \frac{(2,200 + 10 \times (\min(70, S_{FFS}) - 50))}{1 + \%HV/100} \times CAF \quad \text{Equation 16}$$

where

- $C_i$  = capacity of section  $i$  (veh/h/ln),
- $S_{FFS}$  = free-flow speed (mph),
- %HV = percent of heavy vehicles (decimal), with heavy vehicles consisting of trucks with more than four tires, buses, and recreational vehicles (see Exhibit 23 for suggested default values), and
- CAF = capacity adjustment factor, described below, that calibrates the basic section capacity to account for the influences of ramps, weaves, unfamiliar driver populations, and other factors.

Equation 16 is fully consistent with the HCM speed–flow models. Section inputs include section type (basic, weave, or ramp); section length in miles; number of lanes; and directional AADT. This information, together with the global inputs, is used to calculate free-flow travel rate (the inverse of free-flow speed); capacity adjustment factors (CAFs) for weave and ramp sections; adjusted lane capacity (the product of base capacity and CAF); and section capacity (the product of adjusted lane capacity and number of lanes).

### *Mainline Entry and On-Ramp Capacity Constraint*

The estimated hourly mainline entry demands should be compared to the estimated capacity for the mainline entry. If the mainline entry hourly demands exceed the estimated mainline entry capacity, the hourly demands should be set equal to the mainline entry capacity for the purposes of the freeway analysis. The mainline entry capacity is computed using Equation 16.

Similarly, the hourly on-ramp demands should be compared to the estimated on-ramp capacities and any demand in excess of the hourly capacity should be reduced to the hourly capacity. HCM Exhibit 14-12 (HCM 2016) provides nominal on-ramp capacities that can be used in determining the capacity constraint. These capacities are in terms of passenger car equivalents and vary by the ramp free-flow speed. For planning purposes, a nominal value of 2,000 vehicles per hour per lane can be used as an on-ramp capacity. Note that this capacity may exceed that of the ramp merge point with the freeway mainline.

Off-ramp demands may exceed an off-ramp’s capacity, in which case excess demand would be queued on the off-ramp and potentially the freeway. This effect is not accounted for in the simplified method. The existence of this condition indicates the need for a more detailed analysis.

### *Assigning Section Demands*

Daily or peak hour demands are required for each freeway segment. These demands are then converted to 15-minute demands for each section, with unserved demand from a prior 15-minute period being carried over to the following 15-minute period.

The demand level for each section is determined from entering demand, exiting demand, and carry-over demand from a previous analysis period (in the case of over capacity operations). The demand-to-capacity ratio is then calculated, along with the delay rate, as discussed later. For each section and time period, the method further estimates travel rate, travel time, density per lane, and segment queue length. Section inflow and outflow during each of the four 15-minute time periods during the peak hour (i.e.,  $t = 1$  to 4) is computed as follows:

$$q_{i,t} = \begin{cases} AADT_i \times k \times f_{gf} & t = 1,3 \\ AADT_i \times k \times \left( \frac{1}{PHF} \right) \times f_{gf} & t = 2 \\ AADT_i \times k \times \left( 2 - \frac{1}{PHF} \right) \times f_{gf} & t = 4 \end{cases} \quad \text{Equation 17}$$

where

- $q_{i,t}$  = in- or outflow for section  $i$  during analysis period  $t$  (veh/h),
- $AADT_i$  = average annual daily traffic for section  $i$  (veh/day),
- $k$  =  $K$ -factor (decimal) = proportion of daily traffic during the peak hour,
- $PHF$  = peak hour factor (decimal), and
- $f_{gf}$  = growth factor to forecast future demands.

Equation 17 assumes (1) the peak 15-minute flow rate will occur during the second 15-minute period within the peak hour, (2) the first and third 15-minute periods will have average flow rates for the peak hour, and (3) the final 15-minute period within the peak hour will have a lower flow rate to ensure that all four 15-minute periods add up to the total peak hour flow, as shown in Exhibit 24.

The demand level  $d_{i,t}$  in section  $i$  at time  $t$  is computed as the demand level in section  $i - 1$  plus the inflow at section  $i$  at time  $t$  minus the outflow at the same section at time  $t$ , plus any carry-over demand  $d'_{i,t-1}$  in section  $i$  during the previous time interval  $t - 1$ . The relationship is as follows:

$$d_{i,t} = d_{i-1,t} + (q_{i,t})_{in} - (q_{i,t})_{out} + d'_{i,t-1} \tag{Equation 18}$$

The carry-over demand  $d'_{i,t-1}$  at section  $i$  at time  $t$  is the difference between the section demand and capacity as follows, where all variables are as defined previously:

$$d'_{i,t} = \max(d_{i,t} - c_i, 0) \tag{Equation 19}$$

The carry-over demand is also used as an indication of the presence of a queue on the section. Note that queues are considered to be vertical, and are not carried to an upstream link. Section queue length is estimated by dividing the difference in lane demand and capacity by its density. It essentially provides an estimate for how long the queue would spillback at the given density, assuming a fixed number of lanes upstream of the bottleneck.

### Estimating Section Volume-to-Capacity Ratios

The section volume-to-capacity ratios are computed using the section demands and capacities previously computed.

### Off-Ramp Volume-to-Capacity Ratio Check

There may be cases where capacity constraints on the off-ramp, such as the capacity of the intersection approach at the foot of the off-ramp, may result in lower throughput than predicted. In such a situation, the excess demand may queue up on the off-ramp and eventually back up

**Exhibit 24. Allocation of peak hour demand to 15-minute periods.**

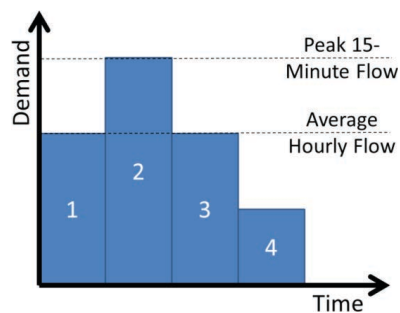

onto the freeway, affecting mainline operations. The complexity of such a situation goes beyond typical planning analysis and may require microsimulation to adequately assess the severity of the problem and its impacts on freeway mainline operations.

### Speed

Section speeds are estimated based on delay rate curves. The estimated delay is added to the estimated travel time at free-flow speed to obtain the travel time with congestion effects. The congested travel time is divided into the section length to obtain the average speed.

#### Estimating Section Delay Rates for Basic Sections

In the following, details for the delay rate estimation are presented for basic sections without the influence of on-ramps or off-ramps. That discussion is followed by recommended adjustments for merge, diverge, and weaving sections.

The procedure estimates delay rate per unit distance as a function of the section’s demand-to-capacity ratio. The delay rate is calculated as the difference between actual and free-flow travel time per unit distance. The calculation of the delay rate needs to be performed separately for undersaturated and oversaturated flow conditions.

**Undersaturated Flow Conditions.** For undersaturated flow conditions, the HCM’s speed–flow model for basic freeway segments is used to estimate delay rates. This model, shown in Equation 20 and Exhibit 25, is a polynomial function fitted to the HCM speed–flow curves. The parameter  $E$  is related to the breakpoint in the HCM speed–flow curves, that is, the demand at which travel speeds begin to decline from the free-flow speed.

$$\Delta_{RU_{i,t}} = \begin{cases} 0 & \frac{d_{i,t}}{c_i} < E \\ A \left( \frac{d_{i,t}}{c_i} \right)^3 + B \left( \frac{d_{i,t}}{c_i} \right)^2 + C \left( \frac{d_{i,t}}{c_i} \right) + D E & \frac{d_{i,t}}{c_i} \leq 1.00 \end{cases} \quad \text{Equation 20}$$

where

- $\Delta_{RU_{i,t}}$  = delay rate for undersaturated section  $i$  at time  $t$  (s/mi),
- $d_{i,t}$  = demand for section  $i$  at time  $t$  (veh/h),
- $c_i$  = section capacity (veh/h), and
- $A, B, C, D, E$  = equation parameters from Exhibit 25.

For each FFS, the sole input to the regression model is the demand-to-capacity ratio.

**Oversaturated Flow Conditions.** For oversaturated flow conditions, the undersaturated model is first applied with a demand-to-capacity ratio of 1.00. An additional oversaturated delay

**Exhibit 25. Values for the parameters of Equation 20.**

FFS (mph)	A	B	C	D	E
75	68.99	-77.97	34.04	-5.82	0.44
70	71.24	-85.48	35.58	-5.44	0.52
65	92.45	-127.33	56.34	-8.00	0.62
60	121.35	-184.84	83.21	-9.33	0.72
55	156.43	-248.99	99.20	-0.12	0.82

rate is approximated assuming uniform arrivals and departures at a freeway bottleneck. This oversaturation delay rate is calculated using the following equation:

$$\overline{\Delta_{RO_{i,t}}} = \frac{T}{2L_i} \left( \frac{d_{i,t}}{c_i} - 1 \right) \quad \text{Equation 21}$$

where

- $\overline{\Delta_{RO_{i,t}}}$  = additional average delay rate due to oversaturation for section  $i$  at time  $t$  (s/mi),
- $T$  = analysis period duration (s), typically 900 s,
- $L_i$  = length of section  $i$  (mi),
- $d_{i,t}$  = demand for section  $i$  at time  $t$  (veh/h), and
- $c_i$  = section capacity (veh/h).

**Section Travel Time.** After determining the delay rate, the section travel rate is determined by adding the delay rate(s) to the travel rate under free-flow conditions. The section travel time is then computed by multiplying the travel rate and the section length, as shown in Equation 22.

$$T_{i,t} = \frac{3,600L_i}{FFS_i} + L_i (\Delta_{RU_{i,t}} + \overline{\Delta_{RO_{i,t}}}) \quad \text{Equation 22}$$

where

- $T_{i,t}$  = travel time for section  $i$  at time  $t$  (s),
- $L_i$  = length of section  $i$  (mi);
- $FFS_i$  = free-flow speed of section  $i$  (mph),
- $\Delta_{RU_{i,t}}$  = delay rate for undersaturated section  $i$  at time  $t$  (s/mi), and
- $\overline{\Delta_{RO_{i,t}}}$  = additional average delay rate due to oversaturation for section  $i$  at time  $t$  (s/mi).

### Adjustments for Weaving Sections

As mentioned above, the basic approach applies the speed–flow model for basic freeway segments to estimate a freeway section’s delay rate and travel speed. When applied to weaving sections, a capacity adjustment factor is required to account for the generally lower capacity in weaving sections compared to basic sections. With this adjusted capacity, the basic section planning method can be applied to weaving sections. The model is as follows:

$$CAF_{\text{weave}} = 0.884 - 0.0752V_r + 0.0000243L_s \leq 1.00 \quad \text{Equation 23}$$

where

- $CAF_{\text{weave}}$  = capacity adjustment factor used for a weaving section (decimal),
- $V_r$  = ratio of weaving demand flow rate to total demand flow rate in the weaving section (decimal), and
- $L_s$  = weaving section length (ft).

For a planning analysis, demand data for specific movements (e.g., freeway-to-ramp, ramp-to-ramp) may not be available. In these cases, it can be conservatively estimated that ramp-to-ramp demand is zero, and that the volume ratio  $V_r$  is the total on- and off-ramp demand divided by the sum of the (unconstrained) mainline demand entering the section and the on-ramp demand.

### Adjustments for Merge and Diverge Sections

**Merge Sections.** Similar to weaving sections, a capacity adjustment factor  $CAF_{\text{merge}}$  is used to generate an equivalent merge section capacity that would yield speeds equivalent to a

basic section speed. In the absence of local data, a value of 0.95 is recommended for  $CAF_{\text{merge}}$  regardless of the merge configuration. However, a user-supplied CAF can also be used and is recommended for a merge segment with known capacity constraints and congestion impacts.

**Diverge Sections.** For diverge segments, an average  $CAF_{\text{diverge}}$  value of 0.97 is recommended. Again, user-specific calibration of this factor is encouraged.

**Ramp Section Capacity Calculation.** The overall capacity of ramp sections is determined from a length-weighted average of the capacity of the merge, basic, and diverge segments within a given section. Note that the effective length of merge and diverge segments are 1,500 feet each in the HCM. If the section is shorter than 3,000 feet, the length of the basic freeway segment is considered to be zero and the length of the merge and diverge segments is assumed to each be equal to half the section length.

### Computing Speed

The procedure determines the travel rate  $TR_{i,t}$  at section  $i$  at time  $t$  by adding the associated travel rate under free-flow conditions  $TR_{FFS}$  and the delay rate  $\overline{\Delta_{R_{i,t}}}$ . It then calculates travel time  $TT_{i,t}$  by multiplying the travel rate by the section rate  $L_i$ :

$$TR_{i,t} = \overline{\Delta_{R_{i,t}}} + TR_{FFS} \quad \text{Equation 24}$$

$$TT_{i,t} = TR_{i,t} \times L_i \quad \text{Equation 25}$$

The average speed  $S_{i,t}$  in section  $i$  at time  $t$  is found as follows:

$$S_{i,t} = \frac{L_i}{TT_{i,t}} \quad \text{Equation 26}$$

### Level of Service

To calculate level of service (LOS), the facility-wide average density is first computed and then the LOS letter is determined from a look-up table.

The density  $D_{i,t}$  of section  $i$  at time  $t$  is found by dividing the section demand  $d_{i,t}$  by its speed  $S_{i,t}$  as follows:

$$D_{i,t} = \frac{d_{i,t}}{S_{i,t}} \quad \text{Equation 27}$$

This mixed vehicle density is converted to units of passenger cars using Equation 28 and Equation 29:

$$D_{PC} = \frac{D}{PHF \times f_{HV}} \quad \text{Equation 28}$$

$$f_{HV} = \frac{1}{1 + P_t(E_{HV} - 1)} \quad \text{Equation 29}$$

where

- $D$  = mixed vehicle density (veh/mi/ln),
- $D_{PC}$  = passenger car density (pc/mi/ln),
- $PHF$  = peak hour factor (decimal),
- $f_{HV}$  = heavy vehicle factor (decimal),
- $P_t$  = percent heavy vehicles (decimal), and
- $E_{HV}$  = passenger car equivalent for heavy vehicles (pc).

Recommended default values for peak hour factor and percent heavy vehicles are provided in Exhibit 23. Default values for  $E_{HV}$  are 2.0 for level terrain and 3.0 for rolling terrain. If specific values for grade, grade length, percent heavy vehicles, and the proportion of single-unit trucks to tractor-trailers are known, HCM Exhibits 12-26 through 12-28 provide more precise values for  $E_{HV}$ .

A weighted average, by lanes and length, of the section densities is used to obtain the average density for the facility.

$$D_F = \frac{\sum D_i \times L_i \times N_i}{\sum L_i \times N_i} \tag{Equation 30}$$

where

- $D_F$  = average passenger car density for the facility (pc/mi/ln),
- $D_i$  = passenger car density for section  $i$  (pc/mi/ln),
- $L_i$  = length of section  $i$  (mi), and
- $N_i$  = number of lanes in segment  $i$  (ln).

The facility and segment passenger car densities are entered into Exhibit 26 to obtain the level of service.

### Queues

A segment is considered to be in 100% queue if its estimated density is greater than 45 passenger car equivalents per mile per lane (pc/mi/ln).

For segments with densities below 45 pc/mi/ln, but demand-to-capacity ratios greater than 1.00, the section queue length is estimated by dividing the difference in lane demand and capacity by its density. It essentially provides an estimate for how long the queue would spillback at the given density, assuming a fixed number of lanes upstream of the bottleneck.

**Exhibit 26. Level of service criteria for freeway facilities.**

Level of Service	Urban/Suburban Freeway	Rural Freeway
	Average Facility or Section Density (pc/mi/ln)	Average Facility or Section Density (pc/mi/ln)
<b>A</b>	≤ 11	≤ 6
<b>B</b>	>11–18	>6–14
<b>C</b>	>18–26	>14–22
<b>D</b>	>26–35	>22–29
<b>E</b>	>35–45	>29–39
<b>F</b>	>45 or any section has $d/c > 1.00$	>39 or any section has $d/c > 1.00$

Source: Adapted from HCM Exhibit 10-6.

Note:  $d/c$  = demand-to-capacity ratio.

$$QL_{i,t} = \frac{\max(d_{i,t} - c_i, 0)}{D_{i,i}} \tag{Equation 31}$$

where

- $QL_{i,t}$  = queue length in segment  $i$  at time  $t$  (veh),
- $d_{i,t}$  = demand on segment  $i$  at time  $t$  (veh/h),
- $c_i$  = capacity of segment  $i$  (veh/h), and
- $D_{i,t}$  = density on segment  $i$  at time  $t$  (veh/mi/ln).

## 7. Reliability

The travel time on a facility will vary from hour to hour, day to day, and season to season of the year, depending on fluctuations in demand, weather, incidents, and work zones. Travel time reliability measures are an attempt to characterize this distribution of travel times for a selected period (often the non-holiday, weekday a.m. or p.m. peak period) of a year in some way meaningful to the analyst, the agency’s objectives, and the general public. Exhibit 27 shows two measures (the 95th percentile travel time index and the percent of trips less than 45 mph) out of many possible measures for characterizing the travel time distribution and communicating travel time reliability to decision-makers and the public. The agency and the analyst may choose other measures or other thresholds (such as the 85th percentile travel time index) for characterizing reliability. (The travel time index is the ratio of the actual or average travel time, depending on the context, to the travel time at free-flow speed.)

The HCM (2016) provides a relatively data- and computationally intensive method for evaluating freeway reliability. The Florida DOT has also developed a reliability analysis procedure (Elefteriadou et al. 2012). Both methods provide defaults for many of the required inputs, but both require custom software to apply. As alternatives, this section describes how the HCM method can be applied with default values and presents a simplified method for estimating the two performance measures shown in Exhibit 27.

**Exhibit 27. Two measures for characterizing travel time reliability.**

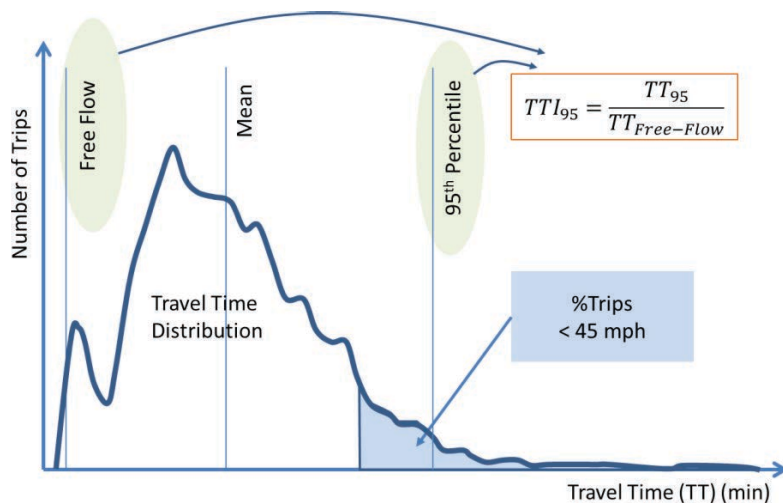



**Exhibit 28. Input data needs for HCM travel time reliability analysis of freeways.**

Data Category	Description	Defaults
<b>Time Periods</b>	Study period, reliability reporting period	Must be selected by the analyst
<b>Demand Patterns</b>	Day-of-week by month-of-year demand factors	Urban: HCM Exhibit 11-18 Rural: HCM Exhibit 11-19
<b>Weather</b>	Probabilities of various intensities of rain, snow, cold, and low visibility by month	Determined by nearest city; specific values provided in the HCM Volume 4 Technical Reference Library
<b>Incidents</b>	Crash rate, incident-to-crash ratio, incident type probability, average incident duration by type	Crash rate: must be provided Incident-to-crash ratio: 4.9 Others: HCM Exhibit 11-22
<b>Work Zones and Special Events</b>	Changes to base conditions (e.g., demand, number of lanes), schedule for occurrence	Optional inputs
<b>Nearest City</b>	Main city in nearest metropolitan area	Required to look up weather defaults
<b>Traffic Counts</b>	Demand multiplier for demand represented in base dataset	Must be provided; equals 1.00 when demands represent AADT

Source: Adapted from HCM (2016), Exhibit 11-10.

Notes: The study period is the portion of the day (e.g., 5 a.m. to 10 a.m.) in which travel time reliability will be evaluated. The reliability reporting period is the specific set of days (e.g., all non-holiday weekdays in a year) for which travel time reliability will be evaluated.

AADT = annual average daily traffic.

### HCM Method Using Defaults

The HCM method for estimating travel time reliability is described in HCM Chapter 11. Exhibit 28 lists the required inputs and identifies which ones have default values available in the HCM.

### Simplified Method

The following equations can be used to estimate freeway facility travel time reliability (Economic Development Research Group et al. 2014, Cambridge Systematics 2014, Elefteriadou et al. 2012). First, the average annual travel time rate (hours per mile), including incident effects, is computed:

$$TTI_m = 1 + FFS \times (RDR + IDR) \tag{Equation 32}$$

$$RDR = \frac{1}{S} - \frac{1}{FFS} \tag{Equation 33}$$

$$IDR = [0.020 - (N - 2) \times 0.003] \times X^{12} \quad X \leq 1.00 \tag{Equation 34}$$

where

- $TTI_m$  = average annual mean travel time index (unitless),
- $FFS$  = free-flow speed (mph),
- $RDR$  = recurring delay rate (h/mi),
- $IDR$  = incident delay rate (h/mi),
- $S$  = peak hour speed (mph),
- $N$  = number of lanes in one direction ( $N = 2$  to  $4$ ), and
- $X$  = peak hour volume-to-capacity ratio (decimal).

Values of  $X$  greater than 1.00 should be capped at 1.00, and values of  $N$  greater than 4 should be capped at 4, for use in Equation 34. Also note that Equation 34 does not explicitly account for differences in significant weather events between facilities and regions.

Next, the 95th percentile travel time index  $TTI_{95}$  and percent of trips traveling under 45 mph  $PT_{45}$  can be computed from the average annual travel time index  $TTI_m$  according to the following equations.

$$TTI_{95} = 1 + 3.67 \times \ln(TTI_m) \quad \text{Equation 35}$$

$$PT_{45} = 1 - \exp[-1.5115 \times (TTI_m - 1)] \quad \text{Equation 36}$$

## 8. Adaptations for Advanced Freeway Management Practices

Although much remains unsettled as to the precise impacts of advanced freeway management practices on freeway capacities and speeds, there is some research on some practices that can be summarized here.

### Active Transportation and Demand Management (ATDM)

HCM Chapter 37, ATDM: Supplemental, provides a general introduction to ATDM strategies and their likely effects on capacity, speed, and travel time reliability.

### Ramp Metering

Ramp metering can result in more efficient merging at the ramp merge. Zhang and Levinson (2010) suggest that ramp metering can increase freeway mainline bottleneck capacity by 2% to 3% by smoothing out demand surges. Additional information on the capacity and performance analysis of dynamic ramp metering can be found in HCM Chapter 37, Section 4.

### HOV and HOT Lanes

Single-lane high-occupancy vehicle (HOV) and high-occupancy toll (HOT) lanes restrict the ability of vehicles in those lanes to pass each other. Thus, capacities are somewhat lower in these situations than they are for the equivalent mixed flow lanes on the freeway, depending on how the HOV or HOT lane is separated from the rest of the lanes on the freeway. *NCHRP Web-only Document 191* (Wang et al. 2012) suggests that capacities on the order of 1,600 to 1,700 vehicles per hour per lane may be appropriate for single HOV and HOT lanes. Section 4 of HCM Chapter 10, Freeway Facilities Core Methodology, provides additional information on the capacity and performance analysis of managed lanes (e.g., HOV and HOT lanes) on freeways.

### Temporary Shoulder Use

Temporary shoulder use opens the shoulder lane to traffic for limited periods each day. Tentative data suggest that the capacity and speed on a temporary shoulder lane are lower than for the adjacent full-time lanes.

### Work Zones

Section 4 of HCM Chapter 10 provides information on the capacity and performance analysis of work zones on freeways.

## Speed Harmonization

Variable speed limit and speed harmonization installations are intended to give drivers advance notice of downstream slowing and to provide recommended speeds for upstream drivers to reduce the shockwaves on freeways. These installations are intended to improve safety and reduce the effects of primary incidents on freeway operations. The magnitudes of these effects depend on the specifics of the installations. At the time of writing, this topic was the subject of FHWA research and it was not clear what the precise effects would be.

## Autonomous and Connected Vehicles

Autonomous, automated, and connected vehicles have the potential to increase or decrease freeway capacities and speeds, depending on the specifics of their implementation. These vehicles may increase reliability by reducing collisions. At the time of writing, this topic was the subject of FHWA research and it was not clear what the precise effects would be.

## 9. Multimodal Level of Service

The HCM does not provide level of service (LOS) measures for trucks, transit, bicycles, and pedestrians on a freeway facility. This section describes alternatives, where applicable.

### Truck LOS

Truck level of service is defined in *NCFRP Report 31* (Dowling et al. 2014) as a measure of the quality of service provided by a facility for truck hauling of freight, as perceived by shippers and carriers. It is measured in terms of the percentage of ideal conditions achieved by the facility for truck operations. Section P of the Guide describes how to calculate truck LOS for freeway facilities.

### Transit LOS

The HCM does not provide a transit LOS measure for freeways. In general, buses will experience the same conditions as other vehicles in the general purpose or managed lanes (where applicable) and could be assigned the same LOS as for motorized vehicle traffic generally. Alternatively, where buses stop along the freeway facility to serve passengers, the transit LOS measure for urban streets described in Section 4 of the Guide could be applied to the stops along the freeway facility, with appropriate adjustments to the assumed average passenger trip length and baseline travel time rate, and considering the pedestrian LOS of the access route to the stop.

### Bicycle and Pedestrian LOS

Bicycle and pedestrian LOS are not generally applicable to freeways because access is usually limited to motor vehicles. Where a multilane path is provided within the freeway right-of-way, its LOS can be estimated using the procedure described in Section O8 of this Guide.

## 10. Example

An example application of the simplified freeway facility method is provided in Case Study 1 in Section T of the Guide.

## 11. References

- Cambridge Systematics, Inc. *IDAS User's Manual*, Table B.2.14. <http://idas.camsys.com/documentation.htm>, accessed August 14, 2014.
- Dowling, R., G. List, B. Yang, E. Witzke, and A. Flannery. *NCFRP Report 31: Incorporating Truck Analysis into the Highway Capacity Manual*. Transportation Research Board of the National Academies, Washington, D.C., 2014.
- Economic Development Research Group, Inc.; Cambridge Systematics, Inc.; ICF International; Texas A&M Transportation Institute; and Weris, Inc. *Development of Tools for Assessing Wider Economic Benefits of Transportation*. SHRP 2 Report S2-C11-RW-1. Transportation Research Board of the National Academies, Washington, D.C., 2014.
- Elefteriadou, L., C. Lu, Z. Li, X. Wang, and L. Jin. *Multimodal and Corridor Applications of Travel Time Reliability*. Final Report, FDOT Contract BDK77 977-10. University of Florida, Gainesville, March 30, 2012.
- Highway Capacity Manual: A Guide to Multimodal Mobility Analysis*. 6th ed. Transportation Research Board, Washington, D.C., 2016.
- Wang, Y., X. Liu, N. Roupail, B. Schroeder, Y. Yin, and L. Bloomberg. *NCHRP Web-Only Document 191: Analysis of Managed Lanes on Freeway Facilities*. Transportation Research Board of the National Academies, Washington, D.C., Aug. 2012. [http://onlinepubs.trb.org/onlinepubs/nchrp/nchrp\\_w191.pdf](http://onlinepubs.trb.org/onlinepubs/nchrp/nchrp_w191.pdf).
- Zhang, L., and D. Levinson. Ramp Metering and Freeway Bottleneck Capacity. *Transportation Research Part A*, Vol. 44. Elsevier Ltd., New York, 2010, pp. 218–235.



# I. Multilane Highways

## 1. Overview

Multilane highways are roadways with a minimum of two lanes in each direction, with traffic signals, roundabouts, or intersections where highway traffic stops (if any) must be spaced more than 2 miles apart. They have either no access control or partial control of access.

This section presents medium-level methods for evaluating single multilane highway sections and facilities.

## 2. Applications

The procedures in this section are designed to support the following planning and preliminary engineering analyses:

- Developing a highway corridor improvement plan,
- Assessing the impact on facility operations of changing or adding more intersection controls, and
- Preparing traffic impact studies for land development.

## 3. Analysis Methods Overview

The HCM provides a method for estimating the performance of multilane highway sections between intersections. It does not provide a method for evaluating multilane highway facilities that combines the operations of uninterrupted-flow sections with the operations of signalized intersections, STOP-controlled intersections, or roundabouts located intermittently along the highway.

This section presents three analysis methods for planning and preliminary engineering applications, as indicated by the unshaded boxes in Exhibit 29:

1. A high-level screening and scoping method that can be used to focus the analysis on only those locations and time periods requiring investigation;
2. The HCM medium-level method for evaluating multilane highway section performance using defaults; and
3. A medium-level procedure for combining intersection and section performance into an estimate of overall multilane facility performance.



**Exhibit 29. Analysis options for multilane highways.**

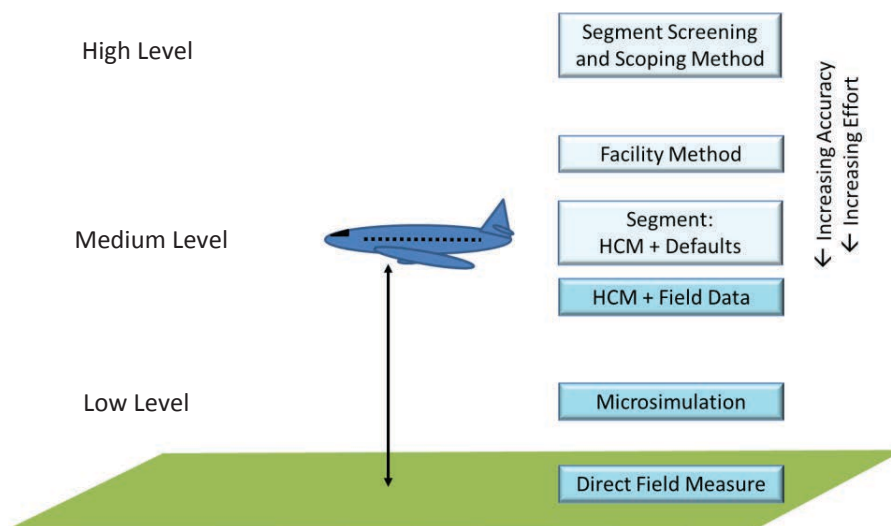

## 4. Scoping and Screening Method

### Generalized Service Volume Table

Whether or not a more detailed multilane highway analysis is needed can be determined by comparing the counted or forecasted peak hour or daily traffic volumes for the sections of the highway between each major intersection to the values given in Exhibit 30. If all of the section volumes fall in the LOS E range or better, there will be no congestion spillover requiring a full facility analysis to better quantify the performance of the facility. One can then use the HCM multilane highway section analysis procedures, with defaults for some of the inputs, to evaluate the performance of each section.

The service volumes in Exhibit 30 can also be used to quickly determine the geographic and temporal extent of the multilane highway that will require analysis. If the counted or fore-

**Exhibit 30. Daily and peak hour service volume and capacity table for multilane highway sections.**

Area Type	Terrain	Peak Hour Peak Direction (veh/h/ln)			AADT (2-way veh/day/ln)		
		LOS A-C	LOS D	LOS E (capacity)	LOS A-C	LOS D	LOS E (capacity)
Urban	Level	1,360	1,700	1,940	12,600	15,700	17,900
Urban	Rolling	1,270	1,580	1,800	11,800	14,600	16,700
Rural	Level	1,220	1,520	1,730	10,200	12,600	14,400
Rural	Rolling	1,100	1,370	1,560	9,200	11,400	13,000

Notes: Entries are maximum vehicle volumes per lane that can be accommodated at stated level of service (LOS).

AADT = annual average daily traffic. AADT per lane is two-way AADT divided by the sum of lanes in both directions.

Urban area assumptions: Free-flow speed = 60 mph, 8% trucks, 0% buses, 0% RVs, peak hour factor = 0.95, capacity adjustment factor for driver population = 1.00, K-factor = 0.09, D-factor = 0.60.

Rural area assumptions: Free-flow speed = 60 mph, 12% trucks, 0% buses, 0% RVs, peak hour factor = 0.88, capacity adjustment factor for driver population = 1.00, K-factor = 0.10; D-factor = 0.60.

Similar tables can be developed by adjusting input values to reflect other assumptions.

The K-factor is the ratio of weekday peak hour two-way traffic to AADT. The D-factor is the proportion of peak hour traffic in the peak direction.

casted volumes for a section fall below the agency's target LOS standard, then the section can be excluded from a more detailed analysis.

Any section that exceeds the capacity values in Exhibit 30 will have queuing that may impact upstream sections and reduce downstream demands. In such a situation, a full facility analysis is required to ascertain the highway's performance. At present, the HCM does not provide such an analysis procedure, so the analyst would have to resort to microsimulation or some other system analysis approach.

The analyst may also use the capacities in Exhibit 30 to compute the peak hour, peak direction demand-to-capacity ratio for each section under various improvement options. The options can then be quickly ranked according to their forecasted demand-to-capacity ratios for the critical sections of the highway.

### Estimating Multilane Highway Service Volumes

The approximate maximum annual average daily traffic (AADT) (two-way) that can be accommodated by a multilane highway at a given level of service can be estimated from Exhibit 30. For example, a four-lane highway (two lanes in each direction) can carry between 49,600 ( $12,400 \times 4$  lanes) and 65,600 ( $16,400 \times 4$  lanes) AADT at LOS E, depending on its location (urban or rural) and the terrain type. Higher AADTs can be accommodated at lower  $K$ - (peak hour proportion) and  $D$ - (directional proportion) factors. Note that the values in this simple example are shown to the nearest hundred but the final result should be considered accurate to the nearest thousand.

A multilane highway in an urban setting delivers between 85% and 90% of the capacity per lane as an urban freeway. A rural multilane highway delivers 95% to 98% of the capacity per lane as a rural freeway.

When local traffic data suggests that other values for the assumptions than those noted in Exhibit 30 would be more appropriate, the analyst should modify the daily and hourly service volumes using this equation:

$$DSV = DSV_0 \times \frac{f_{HV} \times CAF_p \times PHF}{K \times D} \times \frac{K_0 \times D_0}{f_{HV,0} \times CAF_{p,0} \times PHF_0} \quad \text{Equation 37}$$

where

$DSV$  = daily service volume (veh/day/ln),

$DSV_0$  = initial daily service volume in Exhibit 30 (veh/day/ln),

$f_{HV}, f_{HV,0}$  = desired and initial adjustment factors, respectively, for presence of heavy vehicles in the traffic stream,

$CAF_p, CAF_{p,0}$  = desired and initial capacity adjustment factors, respectively, for unfamiliar driver populations,

$PHF, PHF_0$  = desired and initial peak hour factors, respectively,

$K, K_0$  = desired and initial proportions, respectively, of daily traffic occurring during the peak hour, and

$D, D_0$  = desired and initial proportions, respectively, of traffic in the peak direction during the peak hour.

The same equation can be used to modify the peak hour, peak direction service volumes if the initial peak hour service volumes from Exhibit 30 are used instead of the daily values.

The heavy vehicle adjustment factor  $f_{HV}$  used in the service volume table is computed using the following adaptation of HCM Equation 12-10 (HCM 2016):

$$f_{HV} = \frac{1}{1 + P_{HV} \times (E_{HV} - 1)} \quad \text{Equation 38}$$

**Exhibit 31. Heavy vehicle equivalence values for multilane highways.**

Terrain Type	$E_{HV}$
Level	2.0
Rolling	3.0
Mountainous	5.0

Source: Adapted and extrapolated from HCM (2016), Exhibit 12-25.

where

- $f_{HV}$  = heavy vehicle adjustment factor (decimal),
- $P_{HV}$  = percentage heavy vehicles (decimal), and
- $E_{HV}$  = heavy vehicle equivalence from Exhibit 31.

For convenience, all heavy vehicles are assigned a single PCE value from Exhibit 31.

Daily service volumes should be rounded to the nearest hundred vehicles, given the many default values used in their computation. Peak hour, peak direction service volumes should be rounded to the nearest ten vehicles.

**5. Section Analysis Using HCM with Defaults**

HCM Chapter 12, Basic Freeway and Multilane Highway Segments, describes the method for evaluating the capacity, speed, density, and LOS for multilane highway sections without major intersections (i.e., intersections that slow down or stop through traffic on the mainline).

**Data Requirements**

Exhibit 32 lists the data needed to evaluate the full range of performance measures for HCM multilane highway section analysis and for the multilane facility analysis method described in this section.

To evaluate multilane highway sections at a facility level, all of the HCM section-level data listed in Exhibit 32 are required (including section length), plus the intersection-level data for each of the intersection or interchange types found along the multilane facility.

**Section Free-Flow Speeds**

The free-flow speed, representing the speed drivers would choose based only on the highway’s horizontal and vertical alignment, is a critical input for calculating most multilane highway performance measures.

**Exhibit 32. Required data for multilane highway section analysis.**

Input Data (units)	For HCM Section	For Facility Method	Default Value
Hourly directional volume (veh/h)	•	•	Must be provided
Number of directional lanes	•	•	Must be provided
Terrain type (level, rolling, etc.)	•	•	Must be provided*
Lane width (ft)	•	•	12
Total lateral clearance (ft)	•	•	12
Access points/mile	•	•	8 (rural), 16 (low-density suburban), 25 (high-density suburban)
Free-flow speed (mph)	•	•	Must be provided
Percentage heavy vehicles (%)	•	•	10 (rural), 5 (suburban)**
Peak hour factor (decimal)	•	•	0.88 (rural), 0.95 (suburban)
Section length (mi)		•	Must be provided
Intersection performance data		•	Must be provided

Notes: See HCM Chapter 12 for definitions of the required input data.

\*Heavy vehicle impacts on traffic flow on long (≥1 mi) and steep (>4%) grades with relatively few (<5%) trucks can be significantly more severe than the default value for mountainous terrain would indicate. Consideration should be given to developing specific passenger car equivalent values for mountainous sections where these conditions are met.

\*\*HCM Chapter 26, Section 2, provides state-specific default values.



The most-accurate method for estimating free-flow speed is to measure it in the field under low-flow (less than 1,000 vehicles per hour per lane) conditions. The free-flow speed would be the average of the observed spot speeds under those low-flow conditions.

The second-best method is to estimate the free-flow speed using the method provided in the HCM.

The third-best method to estimate the free-flow speed is to use the posted speed limit plus an adjustment deemed appropriate by the analyst (for example: posted speed limit plus 5 mph). The result should be rounded to the nearest 5 mph. Should the posted speed limit for trucks or other vehicle classes be lower than that for other vehicle types, then the analyst will have to apply some judgment based on local experience to estimate the free-flow speed.

## Section Capacities

The capacity of a multilane highway section depends upon its free-flow speed, the peak hour factor, and the effect of heavy vehicles. The HCM also offers a capacity adjustment factor for driver population that adjusts capacity downward, but planning analyses often assume that drivers are familiar with the highway and, thus, no capacity adjustment is made for the driver population.

## 6. Multilane Facility Analysis Method

The multilane highway facility analysis combines the performance estimates produced by the HCM multilane highway section analysis method with the performance results for any controlled intersections on the facility. A controlled intersection is one where the mainline through traffic is required to stop or slow down, such as at a traffic signal, an all-way stop, or a roundabout (see Exhibit 33). A stretch of highway between two controlling intersections may be split into multiple highway sections where there are significant changes in the capacity of the highway (usually caused by changes in the grade, alignment, or number of lanes).

### Estimation of Facility Free-Flow Speed

The facility free-flow speed may be estimated three ways. In order of decreasing accuracy, these are:

- *Field measurement.* The free-flow speed may be directly measured in the field at flow rates below 1,000 vehicles per hour per lane, when measured at least one-half mile from a major intersection (i.e., an intersection where a traffic signal, STOP sign, or roundabout requires mainline traffic to slow down or stop). The *Manual of Transportation Engineering Studies* (Schroeder et al. 2010) describes spot speed measurement techniques.
- *HCM estimation method.* The HCM multilane highway section method may be used to estimate the free-flow speed. This method is likely to be less accurate than field measurement, but it requires fewer resources.
- *Estimate from posted speed.* The free-flow speed may be estimated as the posted or statutory speed limit plus an adjustment that the analyst judges to be appropriate, often 5 to 7 mph. This method is likely to be the least accurate of the three approaches, but it requires the least

**Exhibit 33. Controlled intersections and sections on highway facility.**

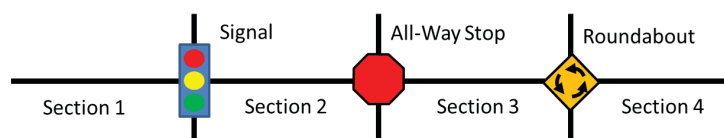

resources and the accuracy is likely to be sufficient for most planning and preliminary engineering applications.

### Level of Service

The HCM does not define LOS at a facility level for multilane highways. However, the multilane highway analysis method described in HCM Chapter 12 can be used to estimate the LOS of the uninterrupted-flow sections between major intersections, while the appropriate HCM method for signalized intersections (Chapter 19), all-way stops (Chapter 21), or roundabouts (Chapter 22) can be used to estimate the LOS of the major intersections. The worst case results can be reported for sections and major intersections.

### Volume-to-Capacity Ratio

The volume-to-capacity ratios are examined for each section and major intersection along the facility. If it is desired to convey a single value to decisionmakers then the highest volume-to-capacity ratio should be reported for the facility.

#### *Highway Sections*

The capacities shown in Exhibit 30 may be used to estimate section capacities between controlled intersections. The more detailed HCM section analysis methods with defaults may be used for a more precise estimate.

#### *Controlled Intersections*

The intersection through movement capacities are estimated using the HCM and the procedures described later in this Guide in Sections L (signalized intersections), M (STOP-controlled intersections), and N (roundabouts).

### Average Travel Speed and Travel Time

The total travel time for the facility is computed by summing the section travel times and the intersection delays to mainline through movements. The average speed for the facility is obtained by dividing the length of the facility by the total travel time.

#### *Highway Sections*

Average travel speed is computed by the HCM method for individual sections. The average travel time for a section (excluding any intersection delays) is calculated as the section length divided by the estimated average section speed:

$$TT_{\text{section}} = \frac{L_{\text{section}}}{S_{\text{section}}} \times 3,600 \quad \text{Equation 39}$$

where

- $TT_{\text{section}}$  = average section travel time (s),
- $L_{\text{section}}$  = section length, including the downstream intersection (mi),
- $S_{\text{section}}$  = average section travel speed (mph), and
- 3,600 = number of seconds in an hour (s/h).

The following equation, adapted from HCM Equation 12-1 and Exhibit 12-6, can be used to estimate average section travel speed. The percent base capacity in the equation is used to convert capacities from vehicles per hour per lane into passenger car equivalents.

**Exhibit 34. Parameters for multilane highway speed estimation.**

Free-Flow Speed (mph)	<i>a</i>	<i>b</i>
70	0.37	6.9
65	0.27	7.3
60	0.23	7.5
55	0.18	7.7
50	0.13	8.1
45	0.07	8.9

Note: This equation produces speed estimates for multilane highways within 2 mph of the HCM-estimated speed for *v/c* ratios ≤ 1.00.

$$S_{\text{section}} = \frac{FFS_{\text{section}}}{1 + a \times (v/c)^b} \tag{Equation 40}$$

where

$S_{\text{section}}$  = average section travel speed (mph),  
 $FFS_{\text{section}}$  = section free-flow speed (mph), and  
 $a, b$  = parameters as given in Exhibit 34.

### Facilities

For facility analyses, the effects of intersection delays at intersections need to be accounted for. The average travel time along a multilane highway facility is estimated by adding intersection delays for through traffic to the estimated section travel times. The average travel speed for through traffic on the facility is then determined by dividing the total travel time into the facility length.

$$TT_{\text{facility}} = \sum_i TT_i + \sum_i d_{i,thru} \tag{Equation 41}$$

$$S_{\text{facility}} = \frac{L_{\text{facility}}}{TT_{\text{facility}}} \times 3,600 \tag{Equation 42}$$

where

$TT_{\text{facility}}$  = average facility travel time (s),  
 $TT_i$  = average section travel time for section *i* (s),  
 $d_{i,thru}$  = average through-vehicle intersection control delay at the intersection at the downstream end of section *i* (s),  
 $S_{\text{facility}}$  = average through-vehicle facility travel speed (mph),  
 $L_{\text{facility}}$  = facility length (mi), and  
 3,600 = number of seconds in an hour (s/h).

### Vehicle-Hours of Delay

Vehicle-hours of delay are calculated by comparing the travel time at an analyst-defined target travel speed to the average travel time, and multiplying by the number of through vehicles. The HCM defines the target travel speed as the free-flow speed. However, some agencies use the speed limit as the basis for calculating delay, while others choose a *threshold* or *policy speed* that the agency considers to be its minimum desirable operating speed.

$$TT_{\text{target,section}} = \frac{L_{\text{section}}}{S_{\text{target,section}}} \times 3,600 \quad \text{Equation 43}$$

$$VHD_{\text{section}} = \frac{(TT_{\text{section}} + d_{\text{thru}} - TT_{\text{target,section}}) \times V_{\text{section,thru}}}{3,600} \geq 0 \quad \text{Equation 44}$$

$$VHD_{\text{facility}} = \sum_i VHD_i \quad \text{Equation 45}$$

where

$TT_{\text{target,section}}$  = target travel time for a section (s),

$L_{\text{section}}$  = section length, including the downstream intersection (mi),

$S_{\text{target,section}}$  = target travel speed for the section (mph),

3,600 = number of seconds in an hour (s/h),

$VHD_{\text{section}}$  = vehicle-hours of delay to through vehicles in a section (veh-h),

$TT_{\text{section}}$  = average section travel time (s),

$d_{\text{thru}}$  = average through-vehicle intersection control delay at the intersection at the downstream end of the section (s),

$V_{\text{section,thru}}$  = vehicle directional demand volume for the section (veh),

$VHD_{\text{facility}}$  = vehicle-hours of delay to through vehicles on the facility (veh-h), and

$VHD_i$  = vehicle-hours of delay to through vehicles in section  $i$  (veh-h).

### Person-Hours of Delay

Person-hours of delay for a section or facility is the corresponding vehicle-hours of delay, multiplied by an assumed average vehicle occupancy.

### Density

Section density is computed according to the following equation, adapted from HCM Equation 12-11:

$$D_{\text{section}} = \frac{(V_{\text{section}}/N)}{S_{\text{section}}} \quad \text{Equation 46}$$

where

$D_{\text{section}}$  = section density (pc/mi/ln),

$V_{\text{section}}$  = vehicle directional demand volume for the section (veh),

$N$  = number of directional lanes (ln),

$S_{\text{section}}$  = average section travel speed (mph).

### Queuing

A section is considered 100% in queue if its density exceeds 45 pc/mi/ln (the density at capacity given in HCM Exhibit 12-6). Queues are meaningful on multilane highways only at the specific bottlenecks causing the queues. Thus queues are estimated and reported by bottleneck (for example, using the appropriate intersection queuing estimation method).

## 7. Reliability

There is currently no method in the HCM or in the literature for estimating the reliability of rural or urban multilane highways.

## 8. Multimodal LOS

### Bicycle LOS

The HCM provides a bicycle LOS measure for multilane highways. For details, see Section O3 in this Guide.

### Pedestrian LOS

The HCM does not provide a pedestrian LOS measure for multilane highways. However, the pedestrian LOS measure for urban streets (see Section O4) was developed in part using data from urban multilane highways and can be applied to facilities whose characteristics are within the range of those used to develop the model (in particular, posted speeds of 50 mph or less).

### Transit LOS

The HCM does not provide a transit LOS measure for multilane highways. However, similar to freeways, if bus service exists along the highway and makes stops to serve passengers, the transit LOS measure for urban streets described in Section O4 of the Guide could be applied to the stops along the multilane highway, with appropriate adjustments to the assumed average passenger trip length and baseline travel time rate.

### Truck LOS

The truck LOS estimation procedure described in Section P can be used to estimate truck LOS for multilane highways.

## 9. Example

Preparation of an example problem was deferred to a future edition of the Guide.

## 10. References

- Highway Capacity Manual: A Guide to Multimodal Mobility Analysis*. 6th ed. Transportation Research Board, Washington, D.C., 2016.
- Schroeder, B. J., C. M. Cunningham, D. J. Findley, J. E. Hummer, and R. S. Foyle. *Manual of Transportation Engineering Studies*, 2nd ed. Institute of Transportation Engineers, Washington, D.C., 2010.



## J. Two-Lane Highways



### 1. Overview

Two-lane highways have one lane for the use of traffic in each direction. The principal characteristic that separates the traffic performance of two-lane highways from other uninterrupted-flow facilities is that passing maneuvers may be allowed to take place in the opposing lane of traffic. Passing maneuvers are limited by the availability of gaps in the opposing traffic stream and by the availability of sufficient sight distance for a driver to discern the approach of an opposing vehicle safely. As demand flows and geometric restrictions increase, opportunities to pass decrease. This creates platoons within the traffic stream, with trailing vehicles subject to additional delay because of the inability to pass the lead vehicles.

Because passing capacity decreases as passing demand increases, two-lane highways exhibit a unique characteristic: operating quality often decreases precipitously as demand flow increases, and operations can become “unacceptable” at relatively low volume-to-capacity ratios. For this reason, few two-lane highways ever operate at flow rates approaching capacity; in most cases, poor operating quality has led to improvements or reconstruction long before capacity demand is reached.

Two-lane highways have no access control or partial control of access. Traffic signals, roundabouts, or STOP signs controlling highway traffic may be found along two-lane highways but must be spaced at least 2 miles apart if the roadway is to be considered a two-lane highway for the purposes of the analysis methods presented in this section.

### 2. Applications

The procedures in this section are designed to support the following planning and preliminary engineering analyses:

- Developing a highway corridor improvement plan,
- Assessing the impacts on facility performance of changing or adding intersection controls,
- Preparing feasibility studies of truck climbing lanes and passing lanes, and
- Conducting traffic impact studies for land development.

### 3. Analysis Methods Overview

The HCM provides a method for estimating the performance of two-lane highway sections between intersections. It does not provide a method or LOS measures for evaluating two-lane high-

**Exhibit 35. Analysis options for two-lane highways.**

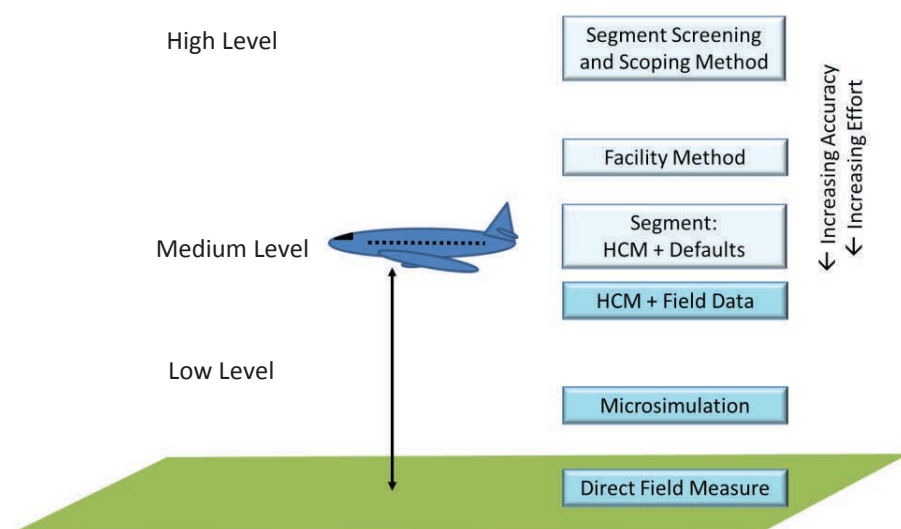

way facilities, combining the operations of sections with signalized intersections, STOP-controlled intersections, or roundabouts.

This chapter presents three analysis methods for planning and preliminary engineering applications, as indicated by the unshaded boxes in Exhibit 35:

1. A high-level screening and scoping method that can be used to focus the analysis on only those locations and time periods requiring investigation,
2. The HCM medium-level method for evaluating two-lane highway section performance using defaults, and
3. A medium-level procedure for combining intersection and section performance to estimate overall two-lane highway facility performance.

## 4. Scoping and Screening

### Generalized Service Volume Table

Whether or not a more detailed two-lane highway analysis is needed can be determined by comparing the counted or forecasted peak hour or daily traffic volumes for the sections of the highway between major intersections (i.e., intersections where highway traffic must stop or slow due to a traffic signal or other form of traffic control) to the values given in Exhibit 36. If all of the section volumes fall in the LOS E range or better, there will be no congestion spillover requiring a full facility analysis to better quantify the performance of the facility. One can then use the HCM two-lane highway section analysis procedures with defaults for some of the inputs to evaluate the performance of each section.

The service volumes in Exhibit 36 can also be used to quickly determine the geographic and temporal extent of the two-lane highway that will require analysis. If the counted or forecasted volumes for a section fall below the agency’s target LOS standard, then the section can be excluded from a more detailed analysis.

Any section that exceeds the capacity values in Exhibit 36 will have queuing that may impact upstream sections and reduce downstream demands. In such a situation, a full facility analysis

**Exhibit 36. Daily and peak hour service volume and capacity table for two-lane highway sections.**

Highway Type	Terrain	Peak Hour Peak Direction (veh/h)			AADT (2-way veh/day)		
		LOS A-C	LOS D	LOS E (capacity)	LOS A-C	LOS D	LOS E (capacity)
Class I	Level	440	750	1,490	7,300	12,500	24,900
Class I	Rolling	340	690	1,450	5,600	11,500	24,100
Class II	Rolling	430	790	1,490	7,100	13,100	24,900

Source: Adapted from HCM (2016), Exhibit 15-5.

Notes: AADT = annual average daily traffic, LOS = level of service.

Entries are maximum vehicle volumes that can be accommodated at the stated LOS.

Class I highways are highways where motorists expect to travel at relatively high speeds. Class II highways are highways where motorists do not necessarily expect to travel at high speed (e.g., access routes to Class I highways, scenic and recreational highways).

Assumed values for Class I—level: base free-flow speed = 65 mph and 20% no-passing zones.

Assumed values for Class I—rolling: base free-flow speed = 60 mph and 40% no-passing zones.

Assumed values for Class II—rolling: base free-flow speed = 50 mph and 60% no-passing zones.

The *K*-factor (ratio of weekday peak hour two-way traffic to AADT) is assumed to be 0.10 for all classes.

The *D*-factor (proportion of peak hour traffic in the peak direction) is assumed to be 0.60 for all classes.

The peak hour factor is assumed to be 0.88 for all classes.

Values can be adjusted for other assumptions.

is required to ascertain the performance of the highway. At present, the HCM does not provide such an analysis procedure, so the analyst would have to resort to microsimulation or some other system analysis approach.

The analyst may also use the capacities in Exhibit 36 to compute the peak hour, peak direction demand/capacity ratio for each section under various improvement options. The options can then be quickly ranked according to their forecasted demand/capacity ratios for the critical sections of the highway.

### Estimating Two-Lane Highway Service Volumes

The approximate maximum two-way annual average daily traffic (AADT) that can be accommodated by a two-lane highway at a given LOS can be estimated from Exhibit 36. For example, a two-lane highway can carry between 24,100 and 24,900 AADT at LOS E, depending on its class and the terrain type. Higher AADTs can be accommodated at lower *K*- (peak hour proportion) and *D*- (directional proportion) factors.

When local traffic data suggest that other values for the assumptions than those noted in Exhibit 36 would be more appropriate, the analyst should modify the daily and hourly service volumes using the following equation:

$$DSV = DSV_0 \times \frac{f_{HV} \times PHF}{K \times D} \times \frac{K_0 \times D_0}{f_{HV,0} \times PHF_0} \tag{Equation 47}$$

where

*DSV* = daily service volume (veh/day/ln),

*DSV*<sub>0</sub> = initial daily service volume in Exhibit 30 (veh/day/ln),



$f_{HV}, f_{HV,0}$  = desired and initial adjustment factors, respectively, for presence of heavy vehicles in the traffic stream,

$PHF, PHF_0$  = desired and initial peak hour factors, respectively,

$K, K_0$  = desired and initial proportions, respectively, of daily traffic occurring during the peak hour, and

$D, D_0$  = desired and initial proportions, respectively, of traffic in the peak direction during the peak hour.

The same equation can be used to modify the peak hour, peak direction service volumes if the initial peak hour service volumes from Exhibit 36 are used instead of the daily values.

The heavy vehicle adjustment factor  $f_{HV}$  used in the service volume table is computed using the following adaptation of HCM Equation 15-4 (HCM 2016):

$$f_{HV} = \frac{1}{1 + P_{HV} \times (E_{HV} - 1)} \tag{Equation 48}$$

where

$f_{HV}$  = heavy vehicle adjustment factor (decimal),

$P_{HV}$  = percentage heavy vehicles (decimal), and

$E_{HV}$  = heavy vehicle equivalence from Exhibit 37.

For convenience, all heavy vehicles are assigned a single PCE value from Exhibit 37 above.

Daily service volumes should be rounded to the nearest hundred vehicles, given the many default values used in their computation. Peak hour, peak direction service volumes should be rounded to the nearest ten vehicles.

## 5. Section Analysis Using HCM with Defaults

HCM Chapter 15, Two-Lane Highways, describes the method for evaluating the capacity, speed, density, and LOS for two-lane highway sections without major intersections (intersections that slow down or stop through traffic on the mainline).

### HCM Highway Classes

Two-lane highway sections are divided into three classes for the purpose of LOS analysis (HCM 2016):

- *Class I two-lane highways* are highways where motorists expect to travel at relatively high speeds. Two-lane highways that are major intercity routes, primary connectors of major traffic generators, daily commuter routes, or major links in state or national highway networks are generally assigned to Class I. These facilities serve mostly long-distance trips or provide the connections between facilities that serve long-distance trips.
- *Class II two-lane highways* are highways where motorists do not necessarily expect to travel at high speeds. Two-lane highways functioning as access routes to Class I facilities, serving as scenic or recreational routes (and not as primary arterials), or passing through rugged terrain (where high-speed operation would be impossible) are assigned to Class II. Class II facilities most often serve relatively short trips, the beginning or ending portions of longer trips, or trips for which sightseeing plays a significant role.
- *Class III two-lane highways* are highways serving moderately developed areas. They may be portions of a Class I or Class II highway that pass through small towns or developed

### Exhibit 37. Heavy vehicle equivalence values for two-lane highways.

Terrain Type	$E_{HV}$
Level	1.1
Rolling	1.5
Mountainous	3.0

Source: Adapted and extrapolated from HCM (2016), Exhibit 15-11.

recreational areas. On such sections, local traffic often mixes with through traffic, and the density of unsignalized roadside access points is noticeably higher than in a purely rural area. Class III highways may also be longer sections passing through more spread-out recreational areas, also with increased roadside densities. Such sections are often accompanied by reduced speed limits that reflect the higher activity level.

## Data Requirements

Exhibit 38 lists the data needed to evaluate the full range of performance measures for HCM two-lane highway section analyses and for the two-lane facility analysis method described later. To evaluate two-lane highways at a facility level, all of the HCM section-level data listed in Exhibit 38 are required, plus the intersection data for the two-lane facility.

## Section LOS

Section-level LOS is an output of the HCM method; step-by-step calculation details are provided in HCM Chapter 15. The HCM section method starts by estimating the free-flow speed based on the geometry of the section and the characteristics of the traffic demands (percent heavy vehicles). The average travel speed is then estimated, followed by the percent time-spent-following. Finally, the LOS and capacity are estimated.

Exhibit 39 presents the automobile LOS criteria for two-lane highway sections for each highway class. The HCM does not define LOS at a facility level for two-lane highways.

**Exhibit 38. Required data for two-lane highway section analysis.**

Input Data (units)	For HCM Section	For Facility Method	Default Value
Hourly two-directional volume (veh/h)	•	•	Must be provided
Directional split (%)	•	•	60/40
Locations and lengths of passing lanes	•	•	Must be provided
Terrain type (level, rolling, mountainous)	•	•	Must be provided*
Highway class (I, II, III)	•	•	Must be provided
Lane width (ft)	•	•	12
Shoulder width (ft)	•	•	6
Percentage no-passing zones (%)	•	•	Level terrain: 20%, rolling: 40%, more extreme: 80%
Access point density, one side (accesses/mi)	•	•	Classes I and II: 8 per mile, Class III: 16 per mile
Base free-flow speed (mph)	•	•	Speed limit + 10 mph
Percentage heavy vehicles (%)	•	•	6**
Peak hour factor (decimal)	•	•	0.88
Section length (mi)	•	•	Must be provided
Intersection performance data		•	Must be provided

Notes: See HCM Chapter 15 for definitions of the required input data.

\*Heavy vehicle impacts on traffic flow on long ( $\geq 1$  mi) and steep ( $>4\%$ ) grades with relatively few ( $<5\%$ ) trucks can be significantly more severe than the default value for mountainous terrain would indicate. Consideration should be given to developing specific passenger car equivalent values for mountainous sections where these conditions are met.

\*\*HCM Chapter 26 provides state-specific default values.

**Exhibit 39. Automobile LOS for two-lane highway sections.**

LOS	Class I Highways		Class II Highways	Class III Highways
	ATS (mph)	PTSF (%)	PTSF (%)	PFFS (%)
A	>55	≤35	≤40	>91.7
B	>50–55	>35–50	>40–55	>83.3–91.7
C	>45–50	>50–65	>55–70	>75.0–83.3
D	>40–45	>65–80	>70–85	>66.7–75.0
E	≤40	>80	>85	≤66.7
F	Demand > capacity			

Source: Adapted from HCM (2016), Exhibit 15-3.

Notes: ATS = average travel speed (excluding intersection delays) (mph), PTSF = percent time-spent-following (%), PFFS = percent of free-flow speed away from signalized or other controlling intersections (e.g., roundabouts and all-way stops) (%).

## 6. Two-Lane Facility Analysis Method

The two-lane highway facility analysis combines the performance estimates produced by the HCM two-lane highway section analysis method with the performance results for any controlled intersections along the facility. A controlled intersection is one where mainline through traffic is required to stop or slow down, such as at a traffic signal, an all-way stop, or a roundabout (see Exhibit 40). A stretch of highway between two controlling intersections may be split into multiple highway sections where there are significant changes in the capacity of the highway (usually caused by changes in the grade or alignment).

### Facility Free-Flow Speed

The facility free-flow speed may be estimated three ways:

- The most accurate approach is to directly measure speeds under low-flow conditions in the field. The field-measured speeds must still be adjusted following the guidance provided in HCM Chapter 15. (It is difficult to find low enough volumes in the field for direct measurement, so the HCM adjustments are required.)
- The next most accurate approach is to use the method in HCM Chapter 15 to estimate the free-flow speed. This method is likely to be less accurate than field measurement, but it requires fewer resources.
- Finally, the free-flow speed may be estimated as the posted or statutory speed limit plus an adjustment that the analyst judges to be appropriate. For two-lane highways, the HCM recommends an upward adjustment of 10 mph (see HCM Exhibit 15-5). This method is likely to be the least accurate of the three approaches, but it requires the least resources and the accuracy is likely to be sufficient for most planning and preliminary engineering applications.

**Exhibit 40. Controlled intersections and sections on highway facility.**

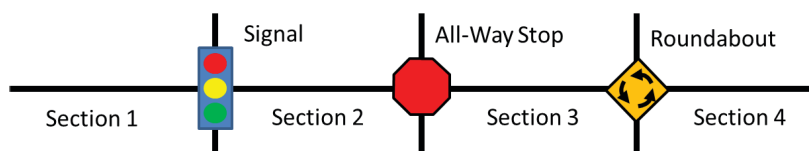

All of these approaches for estimating free-flow speed assume all vehicles have the same posted speed limit. Should the posted speed limit for trucks or other vehicle classes be lower than that for other vehicle types, the analyst will have to apply some judgment based on local experience when employing the above methods to estimate free-flow speed.

### Level of Service

The HCM does not define LOS at a facility level for two-lane highways. However, the two-lane highway section analysis method described in HCM Chapter 15 can be used to estimate the LOS of the sections between controlled intersections, while the appropriate HCM method for signalized intersections (Chapter 19), all-way stops (Chapter 21), or roundabouts (Chapter 22) can be used to estimate the LOS of the controlled intersections. The worst case results can be reported for sections and controlled intersections.

### Volume-to-Capacity Ratio

The volume-to-capacity ratios are examined for each section and controlled intersection along the facility. If it is desired to convey a single value to decision-makers, then the highest volume-to-capacity ratio should be reported for the facility.

#### *Highway Sections*

The capacities shown in Exhibit 36 may be used to estimate section capacities between controlled intersections. The more detailed HCM section analysis methods with defaults may be used for a more precise estimate.

#### *Controlled Intersections*

The intersection through movement capacities are estimated using the HCM and the procedures described in later in this Guide.

### Average Travel Speed and Average Travel Time

The total travel time for the facility is computed by summing the section travel times and the intersection delays to mainline through movements. The average speed for the facility is obtained by dividing the length of the facility by the total travel time.

#### *Highway Sections*

Average travel speed is computed by the HCM method for individual sections. The average travel time for a section (excluding any intersection delays) is calculated as the section length divided by the section speed:

$$TT_{\text{section}} = \frac{L_{\text{section}}}{S_{\text{section}}} \times 3,600 \quad \text{Equation 49}$$

where

$$\begin{aligned} TT_{\text{section}} &= \text{average section travel time (s),} \\ L_{\text{section}} &= \text{section length, including the downstream intersection (mi),} \\ S_{\text{section}} &= \text{average section travel speed (mph), and} \\ 3,600 &= \text{number of seconds in an hour (s/h).} \end{aligned}$$

**Exhibit 41. No-passing adjustment factor (mph) for two-lane highway speed estimation.**

Free-Flow Speed (mph)	200 veh/h < Opposing Volume < 500 veh/h			All Other Opposing Volumes
	0% No-Passing	50% No-Passing	100% No-Passing	
60	2	3	4	1
55	2	3	4	1
50	1	2	4	1
45	1	2	4	1

Source: Adapted from HCM (2016), Exhibit 15-15.

Equation 50 is used to estimate average speed without the effects of passing lanes. The estimated free-flow speed should include the effects of narrow lane widths, restricted right side lateral clearance, and access point density (see HCM Chapter 15 for details). The heavy vehicle factor  $f_{HV}$  in the equation is used to convert capacities from vehicles per hour to passenger car equivalents.

$$S_{base} = FFS - 0.00776 \left( \frac{v_d + v_o}{PHF \times f_{HV}} \right) - f_{NP} \tag{Equation 50}$$

where

- $S_{base}$  = average speed in portions of the section not influenced by passing lanes (mph),
- $FFS$  = free-flow speed (mph),
- $v_d$  = volume in the subject direction (veh/h),
- $v_o$  = volume in the opposite direction (veh/h),
- $PHF$  = peak hour factor (decimal),
- $f_{HV}$  = heavy vehicle adjustment factor (decimal) from Equation 48, and
- $f_{NP}$  = no-passing adjustment factor (mph) from Exhibit 41.

If no-passing lanes are provided in the section, the average section speed  $S_{section}$  equals  $S_{base}$ . Otherwise, one additional step calculates the average section speed as the length-weighted average of the average speed within passing lanes, the average speed in the passing lanes' downstream influence areas, and the average speed in the remainder of the section.

Average speeds are 8 to 11 percent higher where passing lanes exist, relative to the base speed calculated in Equation 50. In addition, passing lanes provide some speed benefit for up to 1.7 miles beyond the end of the passing lane (HCM 2016).

$$S_{section} = \begin{cases} S_{base} N_{pl} = 0 \\ \frac{S_{base} [(f_{pl} \times L_{pl}) + (0.5 f_{pl} \times L_{de}) + L_{mpl}]}{L_{section}} N_{pl} > 0 \end{cases} \tag{Equation 51}$$

where

- $S_{section}$  = average section speed (mph),
- $S_{base}$  = average speed in portions of the section not influenced by passing lanes (mph),
- $N_{pl}$  = number of passing lanes in the section in the analysis direction,
- $f_{pl}$  = speed adjustment factor for passing lanes (decimal) from Exhibit 42,
- $L_{pl}$  = total length of passing lanes in the section (mi),
- $L_{de}$  = total length of passing lane downstream effect in the section (mi),

**Exhibit 42. Speed adjustment factor for passing lanes.**

Directional Volume (veh/h)	$f_{pl}$
≤150	1.08
151–250	1.09
251–550	1.10
>550	1.11

Source: Adapted and extrapolated from HCM (2016), Exhibit 15-28.

$L_{npl}$  = total length of the section not influenced by passing lanes (mi), and  
 $L_{section}$  = total section length (mi).

The maximum value of  $L_{dc}$  is 1.7 miles per passing lane, but this length should be reduced when either a new passing lane begins or the end of the section is reached within 1.7 miles of the end of a passing lane. The total length of the section not influenced by passing lanes  $L_{npl}$  is then  $L_{section}$  minus  $L_{pl}$  minus  $L_{dc}$ , with a minimum value of zero.

### Facilities

For facility analyses, the effects of intersection delays at intersections need to be accounted for. The average travel time along a two-lane highway facility is estimated by adding intersection delays for through traffic to the estimated section travel times. The average travel speed for through traffic on the facility is then determined by dividing the total travel time into the facility length.

$$TT_{\text{facility}} = \sum_i TT_i + \sum_i d_{i,\text{thru}} \quad \text{Equation 52}$$

$$S_{\text{facility}} = \frac{L_{\text{facility}}}{TT_{\text{facility}}} \times 3,600 \quad \text{Equation 53}$$

where

$TT_{\text{facility}}$  = average facility travel time (s),  
 $TT_i$  = average section travel time for section  $i$  (s),  
 $d_{i,\text{thru}}$  = average through-vehicle intersection control delay at the intersection at the downstream end of section  $i$  (s),  
 $S_{\text{facility}}$  = average through-vehicle facility travel speed (mph),  
 $L_{\text{facility}}$  = facility length (mi), and  
 3,600 = number of seconds in an hour (s/h).

### Vehicle-Hours of Delay

Vehicle-hours of delay are calculated by comparing the travel time at an analyst-defined target travel speed to the average travel time, and multiplying by the number of through vehicles. The HCM defines the target travel speed as the free-flow speed. However, some agencies use the speed limit as the basis for calculating delay, while others choose a *threshold* or *policy speed* that the agency considers to be its minimum desirable operating speed.

$$TT_{\text{target,section}} = \frac{L_{\text{section}}}{S_{\text{target,section}}} \times 3,600 \quad \text{Equation 54}$$

$$VHD_{\text{section}} = \frac{(TT_{\text{section}} + d_{\text{thru}} - TT_{\text{target,section}}) \times V_{\text{section,thru}}}{3,600} \geq 0 \quad \text{Equation 55}$$

$$VHD_{\text{facility}} = \sum_i VHD_i \quad \text{Equation 56}$$

where

$TT_{\text{target,section}}$  = target travel time for a section (s),  
 $L_{\text{section}}$  = section length, including the downstream intersection (mi),  
 $S_{\text{target,section}}$  = target travel speed for the section (mph),  
 3,600 = number of seconds in an hour (s/h),

- $VHD_{\text{section}}$  = vehicle-hours of delay to through vehicles in a section (veh-h),  
 $TT_{\text{section}}$  = average section travel time (s),  
 $d_{\text{thru}}$  = average through-vehicle intersection control delay at the intersection at the downstream end of the section (s),  
 $V_{\text{section,thru}}$  = vehicle directional demand volume for the through section (veh),  
 $VHD_{\text{facility}}$  = vehicle-hours of delay to through vehicles on the facility (veh-h), and  
 $VHD_i$  = vehicle-hours of delay to through vehicles in section  $i$  (veh-h).

## Person-Hours of Delay

Person-hours of delay for a section or facility is the corresponding vehicle-hours of delay, multiplied by an assumed average vehicle occupancy.

## Density

Section density is computed according to the following equation, adapted from HCM Equation 12-11:

$$D_{\text{section}} = \frac{V_{\text{section}}}{S_{\text{section}} \times \left( 1 + \frac{L_{pl}}{L_{\text{section}}} \right)} \quad \text{Equation 57}$$

where

- $D_{\text{section}}$  = section density (pc/mi/ln),  
 $V_{\text{section}}$  = vehicle directional demand volume for the section (veh),  
 $S_{\text{section}}$  = average section travel speed (mph),  
 $L_{pl}$  = total length of passing lanes in the section (mi), and  
 $L_{\text{section}}$  = section length, including the downstream intersection (mi).

The  $1 + (L_{pl}/L_{\text{section}})$  term in Equation 57 reduces the density according to the proportion of passing lanes (i.e., two lanes of travel in the analysis direction) in the section.

## Queuing

Queues are meaningful on two-lane highways only at the specific bottlenecks causing the queues. Thus queues are estimated and reported by bottleneck (for example, using the appropriate intersection queuing estimation method). Note that the HCM does not provide methods for evaluating nonintersection bottlenecks that may occur on two-lane highways where large midsection demand surges or significant changes in geometry (e.g., lane drops, grade changes) might create a bottleneck.

## Percent Time-Spent-Following

Percent time-spent-following is used in determining LOS for Class I and Class II two-lane highways. To estimate this measure, the procedures described in HCM Chapter 15 should be used.

## 7. Reliability

There is no method in the HCM or in the literature for estimating the reliability of rural two-lane highways.

## **8. Multimodal LOS**

### **Bicycle LOS**

The HCM provides a bicycle LOS measure for two-lane highways. For details, see Section O3 in this Guide.

### **Pedestrian LOS**

The HCM does not provide a pedestrian LOS measure for two-lane highways.

### **Transit LOS**

The HCM does not provide a transit LOS measure for multilane highways. However, similar to freeways and multilane highways, if bus service exists along the highway and makes stops to serve passengers, the transit LOS measure for urban streets described in Section O4 of the Guide could be applied to the stops along the two-lane highway, with appropriate adjustments to the assumed average passenger trip length and baseline travel time rate.

### **Truck LOS**

The truck LOS estimation procedure described in Section P can be used to estimate truck LOS for two-lane highways.

## **9. Example**

Preparation of an example problem was deferred to a future edition of the Guide.

## **10. Reference**

*Highway Capacity Manual: A Guide to Multimodal Mobility Analysis*. 6th ed. Transportation Research Board, Washington, D.C., 2016.





## K. Urban Streets

### 1. Overview

Any street or roadway with signalized intersections, STOP-controlled intersections, or roundabouts that are spaced no farther than 2 miles apart can be evaluated using the HCM methodology for urban streets and the procedures described in this section.

The planning methods for urban streets focus on facility-level analysis, segment-level analysis, and intersection-level analysis. Facility-level performance is estimated by summing the segment (between intersections) and intersection performance results.

Interchange ramp terminals are a special case of intersection at the foot of freeway on- and off-ramps. They are addressed in HCM Chapter 23. The uneven nature of lane demands and the tight spacing between signals within a freeway interchange result in conditions that are not typical of an urban street.

An urban street segment is a segment of roadway bounded by controlled intersections at either end that require the street's traffic to slow or stop. An urban street facility is a set of contiguous urban street segments. The control delay at the downstream intersection defining a segment is included in the segment travel time. Exhibit 43 shows the relationship between an urban street facility, an urban street segment, and an intersection, as well as the segment travel time and intersection control delay.

The exhibit shows only one direction of a typical bi-directional urban street analysis.



### 2. Applications

The procedures in this chapter are designed to support the following planning and preliminary engineering analyses:

- Development of an urban street corridor improvement plan
- Feasibility studies of
  - Road diets,
  - Complete streets,
  - Capacity improvements,
  - Signal timing improvements,
  - Transit priority timing, and
- Land development traffic impact studies.

**Exhibit 43. Relationships between urban street facility, urban street segments, and intersections.**

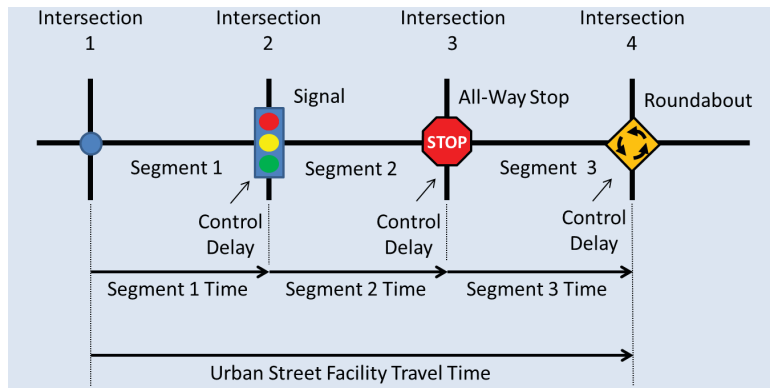

### 3. Analysis Methods Overview

Urban street performance can be directly measured in the field or it can be estimated in great detail using microsimulation. However, the resource requirements of both of these methods render them generally impractical for most planning and preliminary engineering applications.

The HCM provides a less resource-intensive approach to estimating urban street performance; however, it also is generally impractical to use the HCM with 100% field-measured inputs for many planning and preliminary engineering analyses.

As shown by the unshaded boxes in Exhibit 44, this section presents two medium-level methods for evaluating urban street performance, as well as a high-level screening and scoping method that can be used to focus the analysis on only those locations and time periods requiring investigation.

The HCM facility, segment, and intersection analysis methods (covered in HCM Chapters 16 to 23) provide a good basis for estimating urban street performance under many conditions. However, these methods are complex and specialized software is required to implement them. Consequently, a simplified HCM facility analysis method is presented in this section to reduce the number of computations and to enable programming of the method in a static spreadsheet, without requiring writing macros to implement it.

**Exhibit 44. Analysis options for urban streets.**

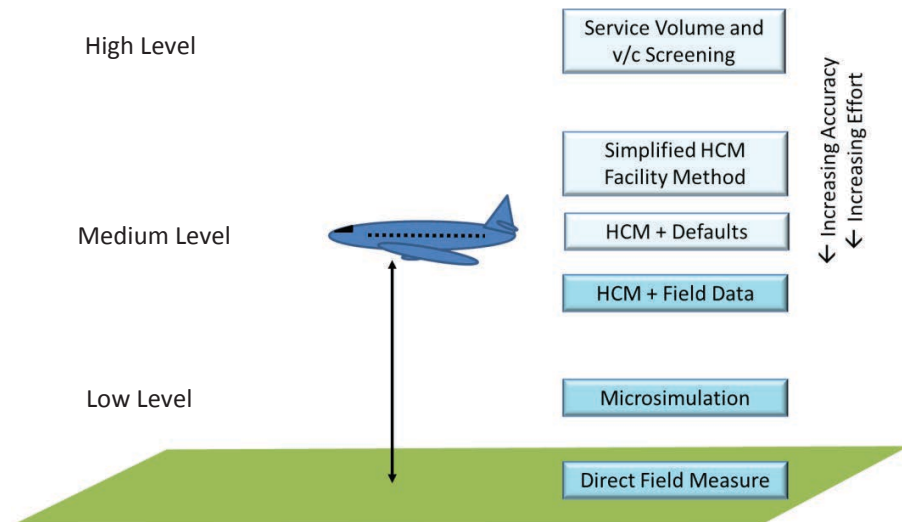

Because all of these methods still require a fair amount of data and computations, this chapter also provides a high-level service volume and volume-to-capacity ratio screening method for quickly identifying which portions of the street will require more detailed analysis (to properly account for the spillover effects of congestion), and to quickly compare improvement alternatives according to the capacity they provide.

## 4. Scoping and Screening

### Generalized Service Volume Tables

Whether or not a more detailed urban street facility analysis is needed can be determined by comparing the counted or forecasted daily or peak hour traffic volumes for the urban street segments between each controlled intersection to the values given the service volume tables presented later in this subsection. If all of the segment volumes fall in the LOS E range or better, there will not be congestion spillover requiring a full facility analysis to better quantify the facility's performance. One can then use the HCM intersection and segment analysis procedures with defaults for some of the inputs to evaluate the performance of each segment and intersection.

The service volumes can also be used to quickly determine the geographic and temporal extent of the urban street facility that will require analysis. If the counted or forecasted volumes for a segment fall within the agency's target LOS standard, then the segment and its associated downstream intersection can be excluded from a more detailed analysis.

#### *HCM Daily Service Volume Table*

HCM Exhibit 16-16 (adapted below as Exhibit 45) provides approximate maximum two-way AADT volumes that can be accommodated by an urban street at a given LOS for two posted speed limits under very specific assumptions of signal timing, signal spacing, access point (unsignalized driveway) spacing, and access point volumes. The service volumes are highly sensitive to the selected assumptions.

#### *Alternative Daily and Peak Hour Service Volume Table*

Exhibit 46 provides maximum service volumes (both two-way AADT and peak hour peak direction) that can be accommodated by an urban street under differing assumptions regarding signal timing, signal spacing, and facility length. The values in this table are expressed on a per-lane basis. For example, a six-lane urban street (three lanes each direction) can carry between 52,200 ( $8,700 \times 6$  lanes) and 81,600 AADT ( $13,600 \times 6$  lanes) at LOS E, depending on the posted speed limit, signal spacing, and traffic signal cycle length. The LOS E service volume is generally also the through capacity at the critical signal on the facility; however, in some situations (as noted in the chart), this volume may be lower than the capacity.

### Intersection Volume-to-Capacity Ratio Checks

The problem with screening at the facility level is that it is possible for the service volume check to show LOS E for the facility when the capacity of one or more intersections along the street has already been exceeded. This condition is especially likely when the signals are widely spaced (i.e., more than one-quarter mile apart). Thus, an intersection volume-to-capacity ( $v/c$ ) ratio check is recommended to supplement the overall facility service volume screening.

The intersection  $v/c$  ratios are computed and screened using the methods described in the intersection sections of this Guide (Section L for signalized intersections, Section M for STOP-controlled intersections, and Section N for roundabouts). The  $v/c$  ratios may be used for study

**Exhibit 45. HCM daily service volume and capacity table for urban streets.**

K-Factor	D-Factor	Two-Lane Streets			Four-Lane Streets			Six-Lane Streets		
		LOS C	LOS D	LOS E	LOS C	LOS D	LOS E	LOS C	LOS D	LOS E
<b>Posted Speed Limit = 30 mph</b>										
0.09	0.55	1,700	11,800	17,800	2,200	24,700	35,800	2,600	38,700	54,000
0.09	0.60	1,600	10,800	16,400	2,000	22,700	32,800	2,400	35,600	49,500
0.10	0.55	1,600	10,700	16,100	2,000	22,300	32,200	2,400	34,900	48,600
0.10	0.60	1,400	9,800	14,700	1,800	20,400	29,500	2,200	32,000	44,500
0.11	0.55	1,400	9,700	14,600	1,800	20,300	29,300	2,100	31,700	44,100
0.11	0.60	1,300	8,900	13,400	1,700	18,600	26,900	2,000	29,100	40,500
<b>Posted Speed Limit = 45 mph</b>										
0.09	0.55	7,700	15,900	18,300	16,500	33,600	36,800	25,400	51,700	55,300
0.09	0.60	7,100	14,500	16,800	15,100	30,800	33,700	23,400	47,400	50,700
0.10	0.55	7,000	14,300	16,500	14,900	30,200	33,100	23,000	46,500	49,700
0.10	0.60	6,400	13,100	15,100	13,600	27,700	30,300	21,000	42,700	45,600
0.11	0.55	6,300	13,000	15,000	13,500	27,500	30,100	20,900	42,300	45,200
0.11	0.60	5,800	11,900	13,800	12,400	25,200	27,600	19,100	38,800	41,500

Source: Adapted from HCM (2016), Exhibit 16-16.

Notes: Entries are maximum vehicle volumes per lane that can be accommodated at stated LOS.

AADT = annual average daily traffic. AADT per lane is two-way AADT divided by the sum of lanes in both directions.

This table is built on the following assumptions:

- No roundabouts or all-way STOP-controlled intersections along the facility.
- No on-street parking and no restrictive median.
- Coordinated, semi-actuated traffic signals, with some progression provided in the analysis direction (i.e., arrival type 4).
- 120-second traffic signal cycle lengths, protected left-turn phases provided for the major street, and the weighted average  $g/C$  ratio (i.e., ratio of effective green time for the through movement in the analysis direction to the cycle length) = 0.45.
- Exclusive left-turn lanes with adequate queue storage are provided at traffic signals and no exclusive right-turn lanes are provided.
- 2-mile facility length.
- At each traffic signal, 10% of traffic on the major street turns left and 10% turns right.
- Peak hour factor = 0.92 and the base saturation flow rate = 1,900 pc/h/ln.
- Additional assumptions for 30-mph facilities: signal spacing = 1,050 ft and 20 access points/mi.
- Additional assumptions for 45-mph facilities: signal spacing = 1,500 ft and 10 access points/mi.

scoping purposes to identify those intersections requiring more detailed analysis. They may also be used to quickly screen capacity-related improvement alternatives.

Any segment that exceeds the capacity of the downstream intersection will have queuing that may impact upstream segments and reduce downstream demands. In such a situation, a full urban street facility analysis using a method capable of accurately identifying queue spillbacks is required to ascertain the performance of the urban street. The facility analysis can be performed using the HCM method with defaults, described later in this section. In cases of severe congestion, a microsimulation analysis may be required to accurately assess queue spillback effects.

The analyst may also use the intersection demand-to-capacity ( $d/c$ ) ratios for each segment to quickly screen various capacity improvement options. Exhibit 47 shows the planning capacities per through lane that may be used to screen for signalized intersection capacity problems. The options can then be quickly ranked according to their forecasted  $d/c$  ratios for the critical segments of the urban street.

**Exhibit 46. Daily and peak hour service volume and capacity table for four-lane urban streets.**

Speed Limit (mph)	Signal Spacing (ft)	Cycle Length (s)	Peak Hour Peak Direction (veh/h/ln)			AADT (2-way veh/day/ln)		
			LOS C	LOS D	LOS E (capacity)	LOS C	LOS D	LOS E (capacity)
25	660	90	630	840	940	5,800	7,800	8,700
25	1,320	120	1,000	1,100	1,100	9,300	10,200	10,200
35	1,320	120	820	1,040	1,100	7,600	9,600	10,200
35	2,640	180	1,300	1,360	1,460	12,000	12,600	13,500
45	1,320	180	630	1,180	1,300*	5,800	10,900	12,000*
45	2,640	180	1,220	1,320	1,400*	11,300	12,200	13,000*
55	2,640	180	1,240	1,320	1,380*	11,500	12,200	12,800*
55	5,280	180	1,340	1,430	1,470	12,400	13,200	13,600
55	10,560	180	1,470	1,470	1,470	13,600	13,600	13,600

Notes: \*The LOS F speed threshold is reached before the through movement volume-to-capacity (v/c) ratio reaches 1.00. In all other cases, the v/c ratio limit of 1.00 for LOS F controls.

Entries are maximum vehicle volumes per lane that can be accommodated at stated LOS.

AADT = annual average daily traffic. AADT per lane is two-way AADT divided by the sum of lanes in both directions.

This table is built on the following assumptions:

- Four-lane facility (two lanes in each direction).
- No roundabouts or all-way STOP-controlled intersections along the facility.
- No on-street parking and no restrictive median.
- Coordinated, semi-actuated traffic signals, with some progression provided in the analysis direction (i.e., arrival type 4).
- Protected left-turn phases provided for the major street, and the weighted average g/C ratio (i.e., ratio of effective green time for the through movement in the analysis direction to the cycle length) = 0.45.
- Exclusive left-turn lanes with adequate queue storage are provided at traffic signals and no exclusive right-turn lanes are provided.
- At each traffic signal, 10% of traffic on the major street turns left and 10% turns right.
- Peak hour factor = 1.00 and base saturation flow rate = 1,900 pc/h/ln.
- The facility is exactly two segments long with exactly three signals, so a facility with 1,320 feet (0.25 mile) between signals is 2,640 feet long.
- Two access points between each traffic signal, regardless of signal spacing. Each access point has two lanes in and two lanes out, with a peak hour volume of 180 veh/h turning into each driveway and 180 veh/h turning out of each driveway.
- K-factor (ratio of weekday peak hour two-way traffic to AADT) = 0.09 and D-factor (proportion of peak hour traffic in the peak direction) = 0.60. For other K- and D- values, multiply AADTs by the assumed factor values (i.e., 0.09 and 0.60) and divide by the desired values.

**Exhibit 47. Signal approach through movement capacities per lane.**

Saturation Flow Rate (veh/h/ln)	Through Movement g/C		
	0.40	0.45	0.50
1,500	600	675	750
1,600	640	720	800
1,700	680	765	850
1,800	720	810	900
1,900	760	855	950

Notes: Entries are through vehicles per hour per through lane.

If exclusive turn lanes are present on the signal approach, then the total approach volumes used to screen for capacity problems should be reduced by the number of turning vehicles. A default value of 20% turns (10% lefts, 10% rights) may be used if both exclusive left- and right-turn lanes are present.

Saturation flow rates, in vehicles per hour of green per lane, are effective rates after adjustments for heavy vehicles, turns, peak hour factor, and other factors affecting saturation flow.

g/C = ratio of effective green time to traffic signal cycle length.

## Sensitivity of Predicted Urban Street Speeds

Analysts should be aware of the following sensitivities of the HCM urban street estimation method:

- The HCM-predicted average speeds under low-flow conditions may be higher or lower than the posted speed limit, depending on the posted speed limit and the signal spacing.
- For through movement v/c ratios below 1.00, average speeds are much more sensitive to changes in v/c ratios than are freeways and highways. For freeways and multilane highways, the speed–flow curve is relatively flat until the v/c ratio at the bottleneck exceeds 1.00. For urban streets, the speed–flow curve drops comparatively rapidly with increasing v/c ratios, even when the v/c ratio is significantly below 1.00.
- As demand increases on an urban street (but is still below a v/c of 1.00), there comes a point in the HCM method where the additional through traffic on the urban street at the unsignalized driveways (access points) can be significantly delayed by the driveways, thereby significantly reducing the predicted speed.
- The HCM-estimated speed ceases to be sensitive to increases in demand once the v/c ratios on the upstream signal approaches feeding the downstream link reach 1.00. Further increases in demand are stored on the upstream signal approaches. The HCM speed estimation method for urban streets does not currently add in the delay to vehicles stored on the upstream signal approaches. For this reason, the HCM arterial method cannot be currently relied upon for speed prediction when the demands on the upstream signal approaches exceed a v/c of 1.00.

## 5. Employing the HCM Method with Defaults

The HCM facility analysis method is described in HCM Chapter 16 and draws from the segment analysis method in HCM Chapter 18. Urban street reliability analysis is described in HCM Chapter 17. Exhibit 48 lists the data needed to evaluate the full range of performance measures for planning-level urban street analysis. Individual performance measures may require only a subset of these inputs.

The estimation of free-flow speeds using the HCM Chapter 17 method requires information on the posted speed limit, median type, presence of a curb, the number of access points per mile, the number of through lanes, and signal spacing.

Urban street capacity, which is determined by the through capacities of the controlled intersections, requires intersection control data, intersection demands, intersection lane geometry, and the analysis period length.

Average speed, motorized vehicle LOS, and multimodal LOS require the intersection capacities and free-flow speed plus additional data on segment lengths, demands, and lanes.

Queues are estimated based on the intersection control, demand, and geometric data.

Reliability analysis requires all the data required to estimate average speed, plus additional information on demand variability, incident frequencies and duration, weather, and work zones.

## 6. Simplified HCM Segment Analysis Method

This simplified urban street segment analysis method assumes that the segments between intersections have no access points between the intersection boundaries and that there are no turning movements at the intersection. All intersections are assumed to be signalized. The method does not consider the effects of a median. Exhibit 49 provides a flow diagram showing the analysis steps for the method.

**Exhibit 48. Required data for urban street analysis with the HCM.**

Input Data (units)	Performance Measures							Default Values
	FFS	Cap	Spd	LOS	MMLOS	Que	Rel	
Posted speed limit (mph)	•		•	•	•		•	Must be provided
Median type	•		•	•	•		•	Must be provided
Curb presence	•		•	•	•		•	Must be provided
Access points per mile	•		•	•	•		•	HCM Exhibit 18-7
Number of through lanes		•	•	•	•	•	•	Must be provided
Segment length (mi)			•	•	•	•	•	Must be provided
Directional demand (veh/h)			•	•	•	•	•	Must be provided
Percentage trucks (%)			•	•	•	•	•	3%
Intersection control data		•	•	•	•	•	•	See Section L, M, or N
Intersection demands		•	•	•	•	•	•	See Section L, M, or N
Intersection geometry		•	•	•	•	•	•	See Section L, M, or N
Analysis period length (h)		•	•	•	•	•	•	0.25 h
Seasonal demand variation							•	HCM Exhibits 17-5 through 17-7
Crash rate (crashes/yr)							•	Must be provided
Incident frequency, duration							•	HCM Exhibits 17-9 through 17-12
Local weather history							•	HCM Volume 4
Work zone probability							•	Optional

Notes: See appropriate sections in text for definitions of the required input data.

Data required for intersection analysis is not shown here. See Section L (signalized intersections),

M (stop-controlled intersections), or N (roundabouts) as appropriate.

FFS = free-flow speed (default = speed limit plus 5 mph), Cap = capacity (veh/h/ln), Spd = average speed (mph), LOS = auto level of service, MMLOS = multimodal LOS (pedestrian, bicycle, transit), Que = queue (vehicles), and Rel = travel time reliability (multiple measures).

**Exhibit 49. Simplified urban street segment analysis method steps.**

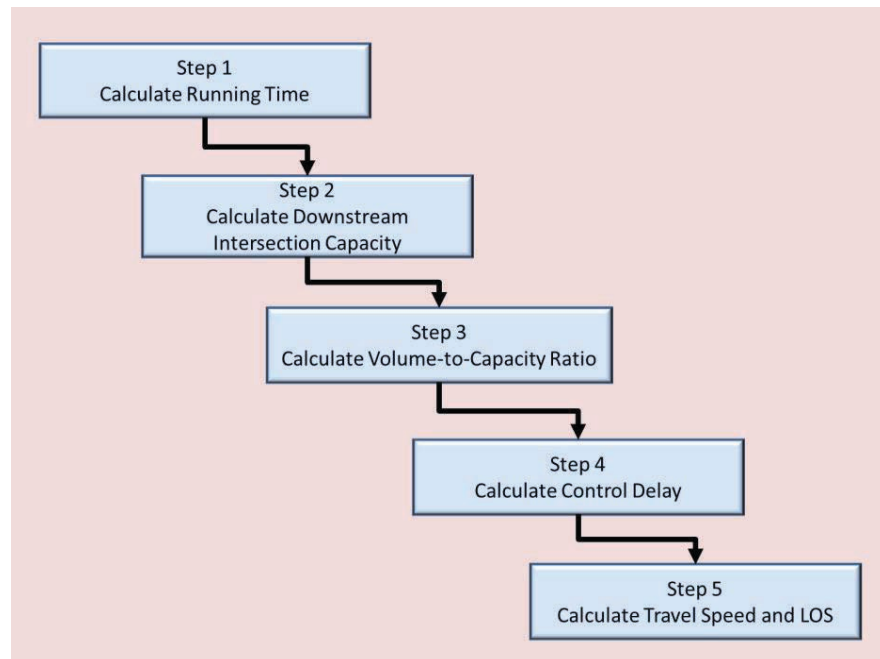

## Input Requirements

The method requires data for four input parameters:

1. The through movement volume along the segment  $v_m$  (veh/h),
2. The number of through lanes on the segment  $N_{TH}$ ,
3. The segment length  $L$  (ft), and
4. The posted speed limit  $S_{pl}$  (mph).

Default values are assumed for five other input parameters:

- Through movement saturation flow rate  $s = 1,900$  veh/h/ln,
- Effective green ratio  $g/C = 0.45$ ,
- Traffic signal cycle length  $C = 120$  s,
- Progression quality along the segment = average, and
- Analysis period duration  $T = 0.25$  h.

As a default, the cycle length is assumed to be 120 seconds and the  $g/C$  ratio is assumed to be 0.45. The latter value assumes that the green time is evenly divided between the north–south and east–west intersection approaches and that lost time accounts for ten percent of the cycle length. The analyst can and should override these defaults based on local knowledge (such as coordination plans). The quality of progression is assumed to be *average* (random arrivals), but the analyst can also select *good* (if there is some degree of coordination between the two signalized intersections) or *poor* (if there is poor coordination between the intersections).

### Step 1: Calculate Running Time

The running time  $t_R$  is calculated as follows:

$$t_R = \frac{3,600 \times L}{5,280 \times (S_{pl} + UserAdj)} \quad \text{Equation 58}$$

where

- $t_R$  = running time excluding intersection delays (s),
- $S_{pl}$  = posted speed limit (mph),
- $UserAdj$  = user-selected adjustment (mph) to reflect the difference between the facility's posted speed limit and the free-flow speed (default = 5 mph), and
- $L$  = segment length (ft).

The default value for  $UserAdj$  assumes that the facility's free-flow speed between controlled intersections is 5 mph greater than the posted speed limit. The analyst may wish to choose an alternative assumption to better reflect local conditions.

### Step 2: Calculate the Capacity of the Downstream Intersection

The capacity of the downstream intersection is calculated as follows:

$$c = g/C \times N_{TH} \times s \quad \text{Equation 59}$$

where

- $c$  = capacity of the downstream intersection (veh/h),
- $g/C$  = effective green ratio for the through movement (default = 0.45) (unitless),



$N_{TH}$  = number of through lanes, and  
 $s$  = saturation flow rate for the through movement (veh/h/ln).

### Step 3: Calculate the Volume-to-Capacity Ratio

The volume-to-capacity ratio for the through movement  $X$  is calculated as follows:

$$X = \frac{v_m}{c} \quad \text{Equation 60}$$

where

$X$  = volume-to-capacity ratio for the through movement (unitless),  
 $v_m$  = through movement volume along the segment (veh/h), and  
 $c$  = capacity of the downstream intersection (veh/h).

### Step 4: Calculate the Control Delay

The control delay  $d$  in seconds per vehicle is determined either from the signalized intersection planning method (see Sections L5) or calculated as described herein.

The uniform delay  $d_1$  is calculated using Equation 61.

$$d_1 = \frac{0.5C(1-g/C)^2}{1 - [\min(1, X)(g/C)]} \quad \text{Equation 61}$$

where

$d_1$  = uniform delay for through vehicles (s/veh),  
 $C$  = traffic signal cycle length (s),  
 $g/C$  = effective green ratio for the through movement (unitless), and  
 $X$  = volume-to-capacity ratio for the through movement (unitless).

The incremental delay  $d_2$  is calculated as follows:

$$d_2 = 225 \left[ (X - 1) + \sqrt{(X - 1)^2 + \frac{16X}{cN_{TH}}} \right] \quad \text{Equation 62}$$

where

$d_2$  = incremental delay for through vehicles (s/veh),  
 $X$  = volume-to-capacity ratio for the through movement (unitless),  
 $c$  = capacity of the downstream intersection (veh/h), and  
 $N_{TH}$  = number of through lanes.

The average control delay  $d$  for through vehicles is calculated using Equation 63.

$$d = d_1PF + d_2 \quad \text{Equation 63}$$

where

$d$  = average control delay for through vehicles (s/veh),  
 $d_1$  = uniform delay for through vehicles (s/veh),  
 $PF$  = progression factor reflecting the quality of signal progression (unitless) from Exhibit 50, and  
 $d_2$  = incremental delay for through vehicles (s/veh).

**Exhibit 50. Progression factor.**

Progression Quality	Progression Factor (PF)
<b>Good</b> (some degree of coordination between the two signalized intersections)	0.70
<b>Average</b> (random arrivals)	1.00
<b>Poor</b> (poor coordination between the intersections)	1.25

**Step 5: Calculate the Average Travel Speed and Determine Level of Service**

The average travel time on the segment  $T_T$  is calculated using Equation 64.

$$T_T = t_R + d \tag{Equation 64}$$

where

- $T_T$  = average through movement travel time (s),
- $t_R$  = running time (s), and
- $d$  = average control delay for through vehicles (s/veh).

The average travel speed on the segment  $S_{T,seg}$  is calculated using Equation 65.

$$S_{T,seg} = \frac{3,600 \times L}{5,280 \times T_T} \tag{Equation 65}$$

where

- $S_{T,Seg}$  = average travel speed for the through movement (mph),
- $L$  = segment length (ft), and
- $T_T$  = average through movement travel time (s).

A spreadsheet-based computational engine has been developed for use in computing each of the data elements. Worksheets for completing the calculations are provided in Exhibit 51.

Once the average speed is estimated, the level of service is looked up in Exhibit 52.

**Extension to Oversaturated Conditions**

Cases in which demand exceeds capacity are common in urban street networks, particularly when considering future planning scenarios. This condition is considered to be sustained when demand exceeds capacity over an entire analysis period, not just for one or two signal cycles. The condition is illustrated in Exhibit 53, where the arrival volume  $v_1$  during the analysis period  $t_1$  exceeds the capacity  $c$  for the downstream intersection approach. During the second analysis period  $t_2$  the arrival volume  $v_2$  is sufficiently low such that the queue that formed during  $t_1$  clears before the end of  $t_2$ . The area between the demand line and the capacity line represents the overflow delay experienced by all vehicles arriving during these two analysis periods. Each of the two analysis periods shown in Exhibit 53 represents a number of signal cycles.

In contrast, the delay resulting from the failure of an individual cycle (“the occasional overflow queue at the end of the green interval”) is accounted for by the  $d_2$  term of the delay equation for signalized intersections and urban street segments. This condition is illustrated in Exhibit 54 where a queue exists for two cycles, but clears in the third cycle. The non-zero slope of the departure

**Exhibit 51. Simplified urban street method worksheets.**

Simplified Urban Street Method, Input Data Worksheet		
Input Data	Direction 1 (EB/NB)	Direction 2 (WB/SB)
Through movement volume $v_m$ (veh/h)		
Number of through lanes $N_{TH}$		
Segment length $L$ (ft)		
Posted speed limit $S_{pl}$ (mph)		
Through move saturation flow rate $s$ (veh/h/ln) (default = 1,900)		
Effective green ratio $g/C$ (default = 0.45)		
Cycle length $C$ (s) (default = 120)		
Progression quality (good, average, poor) (default = average)		
Analysis period $T$ (h) (default = 0.25)		
Simplified Urban Street Method, Calculation Worksheet		
Step 1. Running Time	Direction 1 (EB/NB)	Direction 2 (WB/SB)
Running time (s): $t_R = \frac{3,600 \times L}{5,280 \times (S_{pl} + UserAdj)}$		
Step 2. Capacity	Direction 1 (EB/NB)	Direction 2 (WB/SB)
Capacity (veh/h): $c = g/C \times N_{TH} \times s$		
Step 3. Volume-to-Capacity Ratio	Direction 1 (EB/NB)	Direction 2 (WB/SB)
Volume-to-capacity ratio: $X = \frac{v_m}{c}$		
Step 4. Control Delay	Direction 1 (EB/NB)	Direction 2 (WB/SB)
Uniform delay (s): $d_1 = \frac{0.5C(1-g/C)^2}{1 - [\min(1, X)(g/C)]}$		
Incremental delay (s): $d_2 = 225 \left[ (X - 1) + \sqrt{(X - 1)^2 + \frac{16X}{cN_{TH}}} \right]$		
Progression factor $PF$ : 0.70 (good), 1.00 (average), 1.25 (poor)		
Control delay (s): $d = d_1 PF + d_2$		
Step 5. Average Travel Speed	Direction 1 (EB/NB)	Direction 2 (WB/SB)
Travel time (s): $T_T = t_R + d$		
Travel speed (mph): $S_{T,seg} = \frac{3,600 \times L}{5,280 \times T_T}$		

Note: EB = eastbound, NB = northbound, WB = westbound, SB = southbound.

**Exhibit 52. Urban street LOS average speed thresholds.**

LOS	Base Free-Flow Speed (mph)						
	55	50	45	40	35	30	25
A	>44	>40	>36	>32	>28	>24	>20
B	>37	>34	>30	>27	>23	>20	>17
C	>28	>25	>23	>20	>18	>15	>13
D	>22	>20	>18	>16	>14	>12	>10
E	>17	>15	>14	>12	>11	>9	>8
F	≤17	≤15	≤14	≤12	≤11	≤9	≤8

or any  $v/c > 1.0$

Source: HCM (2016), Exhibit 16-3.

Notes: Entries are minimum average travel speeds (mph) for a given LOS.

The base free-flow speed is estimated as described in HCM Chapter 18, page 18-28, or can be approximated by adding 5 mph (or other appropriate adjustment) to the posted speed limit.

$v/c$  = volume-to-capacity ratio for the through movement in the analysis direction at the boundary intersection.

**Exhibit 53. Overflow delay when demand exceeds capacity over the analysis period.**

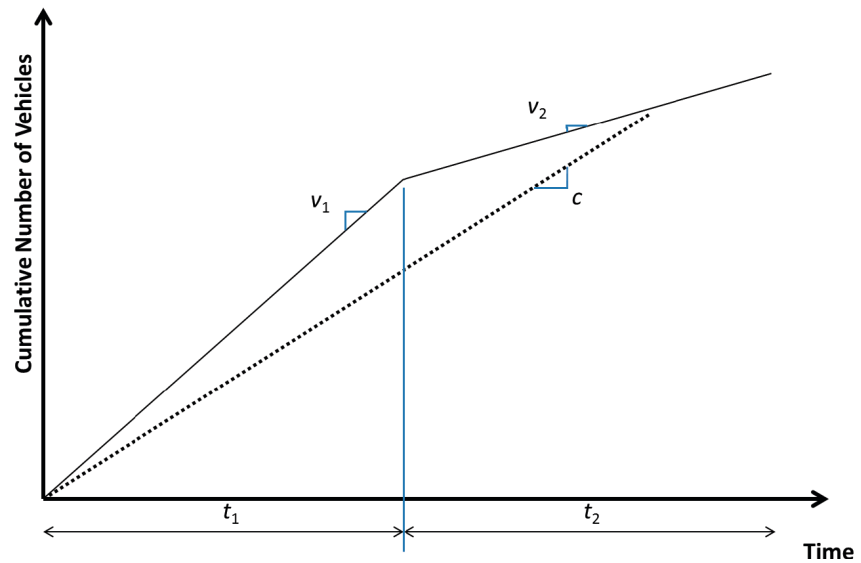

line during the green interval is equal to the saturation flow rate. The slope of the capacity line is the product of the saturation flow rate and the green ratio. The condition shown in Exhibit 54 is not considered to be sustained oversaturation and is therefore not addressed by the method described in this section.

*Overview of the Method*

The urban street segment planning method for oversaturated conditions predicts the overflow delay that results when the demand volume on an urban street segment exceeds its capacity. The method also predicts the  $v/c$  ratio for the first analysis period. The method considers only the

**Exhibit 54. Delay resulting when demand is less than capacity over the analysis period.**

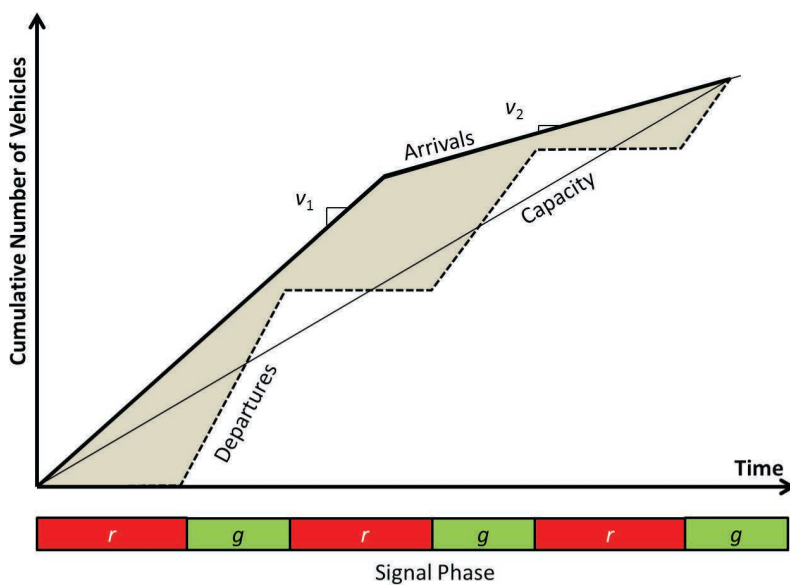

through traffic on the segment. The method considers a queue that may exist at the beginning of the analysis period, the queue that exists at the end of the analysis period, and the time that it takes for this queue to clear during a second analysis period. The framework for determining the effect of oversaturation in the urban street segment is shown in Exhibit 55.

### Limitations of the Method

The method does not consider mid-section movements or turning movements at the downstream intersection. The method does not consider the operational impacts of the queue spillback that result from the oversaturated conditions. The method can be used to analyze oversaturated conditions that result from demand exceeding capacity during several analysis periods. However, during the final analysis period, the demand must be such that the queue clears during this period.

### Input Data Requirements

The input data requirements for the method include the following nine parameters:

- Arrival volumes  $v_1$  and  $v_2$  (veh/h) for the through movement at the downstream intersection during analysis period 1 (the period of oversaturation) and analysis period 2 (the period when the queue clears);
- Analysis period duration  $T$  (h);
- Segment length  $L$  (ft);
- Initial queue  $Q_0$  (veh) existing at the beginning of analysis period 1 for the through movement at the downstream intersection;
- Number of through lanes in the segment  $N_{TH}$ ;
- Saturation flow rate  $s$  for the downstream signalized intersection (veh/h/ln); and
- Cycle length  $C$  (s) and effective green ratio  $g/C$  at the downstream signalized intersection.

Default values are assumed for four of these parameters:

- $T = 0.25$  h,
- $s = 1,900$  veh/h/ln,
- $C = 120$  s, and
- $g/C = 0.45$ .

### Computational Steps

The planning method for urban street segments during periods of oversaturation is a simplified version of the operational analysis method for urban street segments for oversaturated

**Exhibit 55. Oversaturated urban street segment planning method analysis framework.**

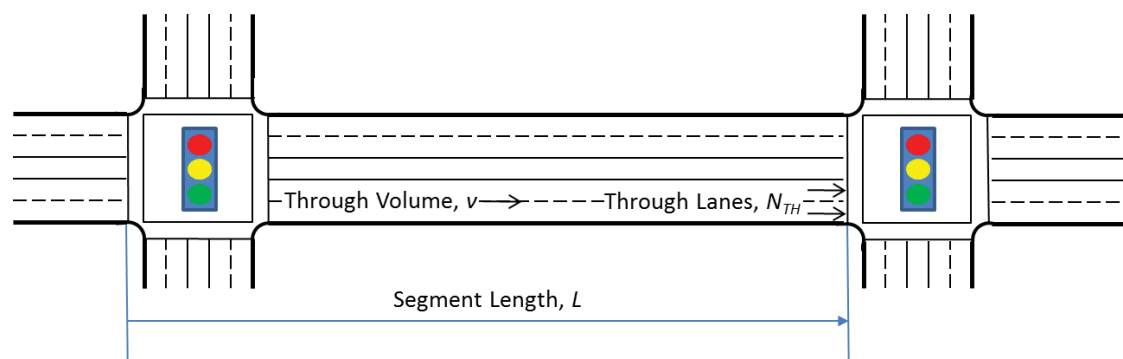

conditions described in HCM Chapter 30. The method includes nine steps, shown in Exhibit 56 and described below.

**Step 1: Calculate Queue Storage Capacity**

The queue storage capacity  $Q_{cap}$  is the number of vehicles that can be stored in the segment, assuming an average vehicle length of 25 ft. The queue storage capacity is calculated as follows:

$$Q_{cap} = \frac{N_{TH}L}{25} \tag{Equation 66}$$

where

- $Q_{cap}$  = queue storage capacity (veh),
- $N_{TH}$  = number of through lanes in the subject direction, and
- $L$  = segment length (ft).

**Step 2: Calculate Available Queue Storage**

This step calculates the available queue storage  $Q_a$  in the segment during analysis period 1 after accounting for any initial queue  $Q_0$  that is present at the beginning of the analysis period. The available queue storage is calculated using Equation 67.

$$Q_a = Q_{cap} - Q_0 \tag{Equation 67}$$

where

- $Q_a$  = available queue storage capacity (veh) during analysis period 1,
- $Q_{cap}$  = queue storage capacity (veh), and
- $Q_0$  = initial queue (veh) at the beginning of analysis period 1.

**Exhibit 56. Urban street segment planning method, oversaturated conditions.**

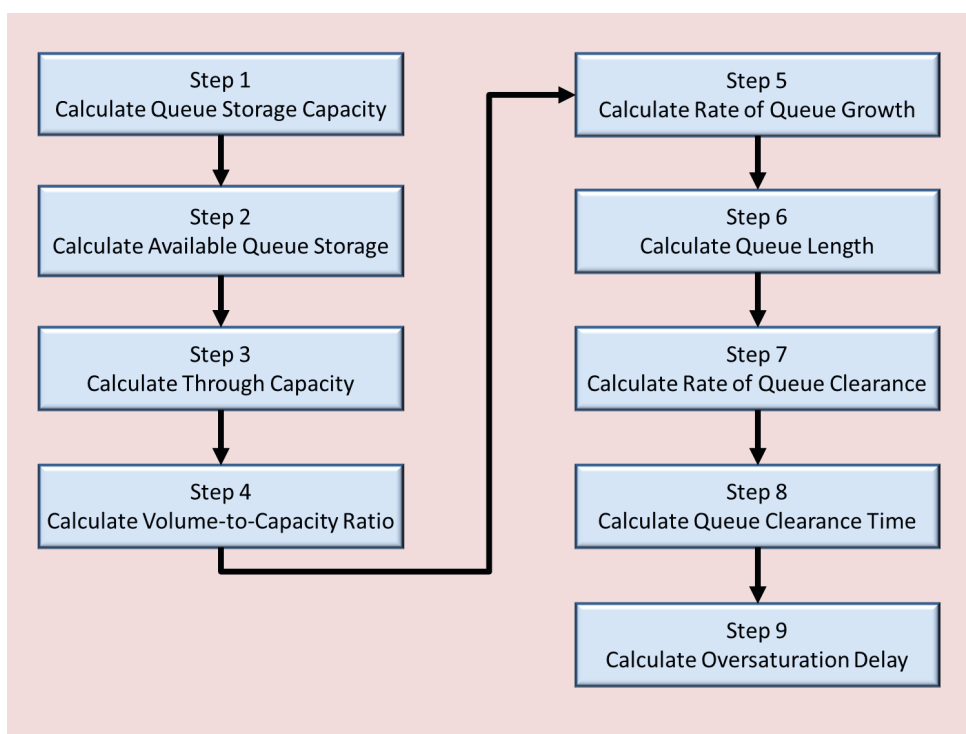

The available queue storage  $Q_a$  is compared to the estimated maximum queue (computed later) to identify queue overflow problems.

### Step 3: Calculate Through Movement Capacity

Equation 68 is used to calculate the capacity of the through movement  $c_{TH}$  at the downstream signalized intersection.

$$c_{TH} = N_{TH}s \left( \frac{g}{C} \right) \quad \text{Equation 68}$$

where

- $c_{TH}$  = through movement capacity at the downstream signal (veh/h),
- $s$  = saturation flow rate for the through movement (veh/h),
- $g$  = effective green time for the through movement (s), and
- $C$  = traffic signal cycle length (s).

### Step 4: Calculate Volume-to-Capacity Ratio

The volume-to-capacity ratio  $X$  for the segment during analysis period 1 is calculated as follows:

$$X = \frac{v_1}{c_{TH}} \quad \text{Equation 69}$$

where

- $X$  = volume-to-capacity ratio for the through movement (unitless),
- $v_1$  = arrival volume (veh/h) during analysis period 1, and
- $c_{TH}$  = through movement capacity at the downstream signal (veh/h).

### Step 5: Calculate Rate of Queue Growth

This step calculates the rate of queue growth  $r_{qg}$  during analysis period 1. If the through movement arrival volume  $v_1$  is less than the capacity, no queue forms and this method is not needed. Equation 70 is used to calculate the rate of queue growth.

$$r_{qg} = v_1 - c_{TH} \geq 0.0 \quad \text{Equation 70}$$

where

- $r_{qg}$  = rate of queue growth (veh/h) during analysis period 1,
- $v_1$  = arrival volume (veh/h) during analysis period 1, and
- $c_{TH}$  = through movement capacity at the downstream signal (veh/h).

### Step 6: Calculate Queue Length

The length of the queue  $Q_{max}$  at the end of analysis period 1 is determined as follows:

$$Q_{max} = r_{qg}t_1 \quad \text{Equation 71}$$

where

- $Q_{max}$  = queue length (veh) at the end of analysis period 1,
- $r_{qg}$  = rate of queue growth (veh/h) during analysis period 1, and
- $t_1$  = duration of analysis period 1 (h).

### Step 7: Calculate Queue Clearance Rate

The rate of queue clearance  $r_{qc}$  during analysis period 2 is calculated as follows:

$$r_{qc} = c_{TH} - v_2 \quad \text{Equation 72}$$

where

$r_{qc}$  = rate of queue clearance (veh/h) during analysis period 2,  
 $c_{TH}$  = through movement capacity at the downstream signal (veh/h), and  
 $v_2$  = arrival volume (veh/h) during analysis period 2.

### Step 8: Calculate Queue Clearance Time

The time for the queue to clear depends on the length of the queue at the end of analysis period 1, the arrival volume during analysis period 2, and the capacity of the through movement for the downstream intersection. If the queue does not clear before the end of analysis period 2, the volumes during subsequent analysis periods must be considered and the queue clearance time calculation must be modified to account for this result. The queue clearance time  $t_c$  is calculated using Equation 73.

$$t_c = \frac{r_{qg}t_1}{r_{qc}} = \frac{Q_{max}}{c_{TH} - v_2} \quad \text{Equation 73}$$

where

$t_c$  = queue clearance time (h),  
 $r_{qg}$  = rate of queue growth (veh/h) during analysis period 1,  
 $t_1$  = duration of analysis period 1 (h),  
 $r_{qc}$  = rate of queue clearance (veh/h) during analysis period 2,  
 $Q_{max}$  = queue length (veh) at the end of analysis period 1,  
 $c_{TH}$  = through movement capacity at the downstream signal (veh/h), and  
 $v_2$  = arrival volume (veh/h) during analysis period 2.

### Step 9: Calculate Oversaturated Delay

The final step calculates the delay resulting from oversaturation  $d_{sat}$ . Exhibit 57 shows the queue accumulation polygon for oversaturated conditions in which a queue grows during analysis period 1 and clears during analysis period 2. The area of the polygon that is formed by these conditions is the delay resulting from the oversaturated conditions. The average delay per vehicle is calculated as follows:

$$d_{sat} = \frac{0.5(Q_{max} - Q_0)t_1 + 0.5t_c Q_{max}}{v_1 t_1 + v_2 t_c} \quad \text{Equation 74}$$

where

$d_{sat}$  = delay resulting from oversaturation (s/veh),  
 $Q_{max}$  = queue length at the end of analysis period 1 (veh),  
 $Q_0$  = initial queue (veh) at the beginning of analysis period 1,  
 $t_1$  = duration of analysis period 1 (h),  
 $t_c$  = queue clearance time (h),  
 $v_1$  = arrival volume (veh/h) during analysis period 1, and  
 $v_2$  = arrival volume (veh/h) during analysis period 2.



**Exhibit 57. Queue accumulation polygon for oversaturated conditions.**

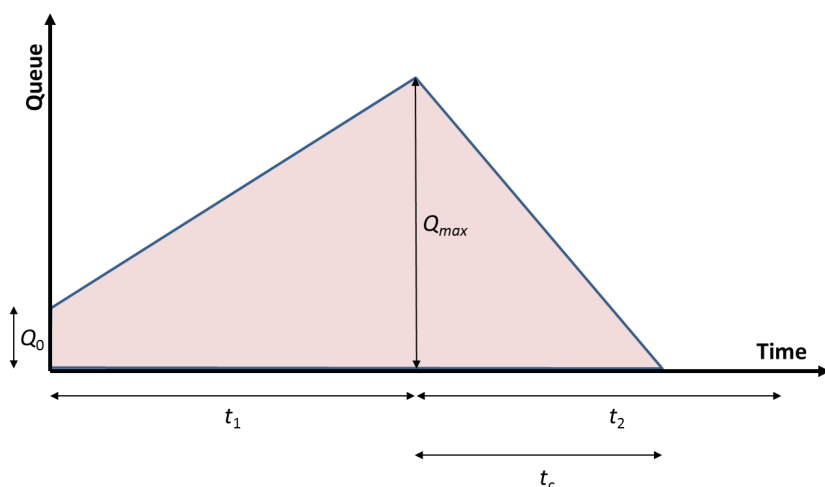

### Computational Tools

A spreadsheet has been developed for use in calculating each of the data elements. A worksheet for completing the calculations is provided as Exhibit 58.

## 7. Reliability Analysis

HCM Chapter 17 describes a method for estimating urban street reliability that is sensitive to demand variations, weather, incidents, and work zones. The Florida DOT has also developed a method for estimating reliability for urban streets (Elefteriadou et al. 2013). Both methods are data- and computationally intensive, requiring custom software to implement. As such, neither method is readily adaptable to a planning and preliminary application that could be programmed in a simple, static spreadsheet. Analysts wishing to perform a reliability analysis of urban streets should consult these sources.

## 8. Multimodal LOS

### Bicycle, Pedestrian, and Transit LOS

The HCM provides methods for evaluating bicycle, pedestrian, and transit LOS on urban streets, which are described in Section O4.

### Truck LOS

The HCM does not provide a truck LOS method. However, the truck LOS estimation procedure described in Section P can be used to estimate truck LOS for urban streets.

## 9. Example

Case Study 2 (Section U) provides an example application of the screening and simplified analysis methods described in this section.

**Exhibit 58. Oversaturated urban street segment planning method worksheet.**

Oversaturated Urban Street Segment Planning Method, Input Data Worksheet	
<b>Input Data</b>	
Arrival volume, time period 1 $v_1$ (veh/h)	
Arrival volume, time period 2 $v_2$ (veh/h)	
Analysis period duration $T$ (h)	
Segment length $L$ (ft)	
Initial queue $Q_0$ (veh)	
Number of through lanes $N_{TH}$	
Through movement saturation flow rate $s$ (veh/h/ln)	
Effective green ratio $g/C$	
Cycle length $C$ (s)	
Oversaturated Urban Street Segment Planning Method, Calculation Worksheet	
<b>Step 1: Queue Storage Capacity (veh)</b>	
$Q_{cap} = \frac{N_{TH}L}{25}$	
<b>Step 2: Available Queue Storage (veh)</b>	
$Q_a = Q_{cap} - Q_0$	
<b>Step 3: Capacity of Through Movement (veh/h)</b>	
$c_{TH} = N_{TH}s \left(\frac{g}{C}\right)$	
<b>Step 4: Volume-to-Capacity Ratio</b>	
$X = \frac{v_1}{c_{TH}}$	
<b>Step 5: Rate of Queue Growth (veh/h)</b>	
$r_{qg} = v_1 - c_{TH} \geq 0.0$	
<b>Step 6: Length of Queue (veh)</b>	
$Q_{max} = r_{qg}t_1$	
<b>Step 7: Rate of Queue Clearance (veh/h)</b>	
$r_{qc} = c_{TH} - v_2$	
<b>Step 8: Time of Queue Clearance (h)</b>	
$t_c = \frac{r_{qg}t_1}{r_{qc}} = \frac{Q_{max}}{c_{TH} - v_2}$	
<b>Step 9: Oversaturation Delay (s)</b>	
$d_{sat} = \frac{0.5(Q_{max} - Q_0)t_1 + 0.5t_c Q_{max}}{v_1t_1 + v_2t_c}$	

## 10. References

- Eleftheriadou, L., Z. Li, and L. Jin. *Modeling, Implementation, and Validation of Arterial Travel Time Reliability*. Final Report, FDOT Contract BDK77 977-20, University of Florida, Gainesville, Nov. 30, 2013.
- Highway Capacity Manual: A Guide to Multimodal Mobility Analysis*. 6th ed. Transportation Research Board, Washington, D.C., 2016.



# L. Signalized Intersections

## 1. Overview

A signalized intersection is an intersection or midblock crosswalk where some or all conflicting movements are controlled by a traffic signal. The procedures presented here can also be adapted to the analysis of freeway ramp meters and traffic signals used to meter traffic flow into a roundabout.

Signalized interchange ramp terminals are a special case of signalized intersections at the foot of freeway on- and off-ramps. They are addressed in HCM Chapter 23. The uneven nature of lane demands and the tight spacing between signals within a freeway interchange result in conditions that are not typical of an urban street.

HCM Chapter 23 also presents methods for analyzing signalized *alternative intersections*, where one or more movements are rerouted to secondary intersections. To the extent that movements of interest to a planning analysis are not diverted (e.g., through movements on an arterial street), the planning-level procedures in this section can be used. The analysis of movements that are diverted requires a more detailed analysis, such as the methods described in HCM Chapter 23.

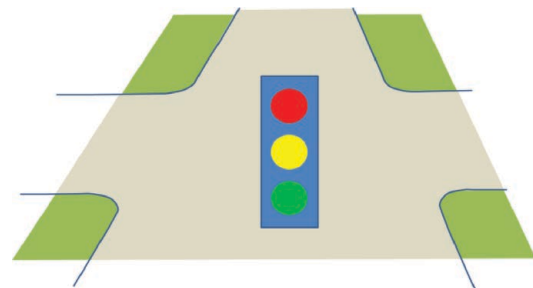

## 2. Applications

The procedures in this section are designed to support the following planning and preliminary engineering analyses:

- Feasibility studies of
  - Intersection improvements, and
  - Signal timing improvements, and
- Land development traffic impact studies.

## 3. Analysis Methods Overview

Intersection performance can be directly measured in the field or it can be estimated in great detail using microsimulation. The resource requirements of both of these methods render them generally impractical for most planning and preliminary engineering applications.

HCM Chapter 19 provides a much less resource-intensive approach to estimating intersection performance; however, it is generally impractical to use the HCM methods with 100 percent field-measured inputs for many planning and preliminary engineering analyses.

**Exhibit 59. Analysis options for signalized intersections.**

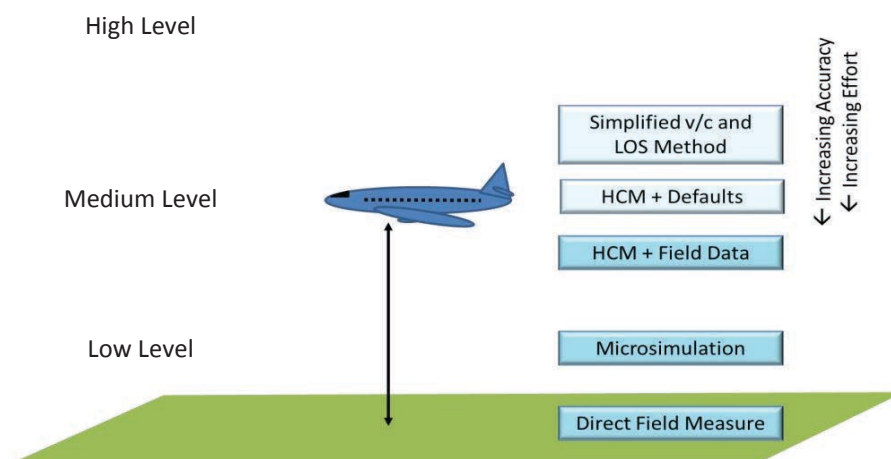

Employing the HCM method with defaults identified in HCM Chapter 19 reduces the data requirements, but still requires specialized software to implement the complex computations.

As indicated by the unshaded boxes in Exhibit 59, this section presents a medium-level method for evaluating signalized intersections, portions of which can be used to perform a high-level screening and scoping analysis to focus the planning and preliminary engineering analysis on only those intersections and time periods requiring investigation. This simplified volume-to-capacity (*v/c*) ratio and level of service (LOS) method can be easily programmed in a static spreadsheet without requiring knowledge of macros.

Exhibit 60 lists the input data required for conducting a planning analysis for signalized intersections. The analyst is required to specify values for two of the parameters, the volume for each movement and the number of lanes (and the turn designation for each) on each approach. If only approach volumes are known, one of the methods described in Section D8 can be used to generate turning-movement volumes. Default values can be assumed for the other seven input parameters, or the analyst can specify the parameter values if they are known.

**Exhibit 60. Required data for signalized intersection analysis.**

Input Data (units)	Performance Measure					Default Value
	Cap	Del	LOS	MMLOS	Que	
Number of turn lanes	•	•	•	•	•	Must be provided
Other geometry	•	•	•	•	•	HCM Exhibit 19-11
Signal timing	•	•	•	•	•	HCM Exhibits 19-11 and 19-17
Peak hour factor (decimal)	•	•	•		•	0.90 (total entering volume <1,000 veh/h), 0.92 (otherwise)
Percentage heavy vehicles (%)	•	•	•	•	•	3%
Parking activity	•	•	•	•	•	None
Pedestrian activity	•	•	•	•	•	None
Volumes by movement (veh/h)		•	•	•	•	Must be provided
Analysis period length (h)		•	•		•	0.25 h

Notes: See the text for definitions of the required input data.

Cap = capacity (veh/h/ln), Del = delay (s), LOS = auto level of service, MMLOS = multimodal LOS (bicycle, pedestrian, transit), Que = queue (veh).

“Other geometry” data include lane widths, bus stops, and pedestrian crossings.

“Signal timing” data include cycle length, effective green time, lost time, progression, and phasing.

Parking activity at the intersection is characterized as either allowed or prohibited (default). Pedestrian activity is characterized as follows:

- None (default)
- Low – 50 pedestrians per hour
- Medium – 200 pedestrians per hour
- High – 400 pedestrians per hour
- Very High – 800 pedestrians per hour

#### 4. Simplified Method, Part 1: Volume-to-Capacity Ratio Calculation

Whether an intersection requires more detailed analysis can be determined quickly by estimating its volume-to-capacity ( $v/c$ ) ratio. These ratios can also be used to quickly compare different capacity improvement alternatives and select the more cost-effective alternatives for further analysis.

A critical movement analysis is used to predict the critical  $v/c$  ratio of the intersection and make an assessment of the sufficiency of the intersection to accommodate the forecasted peak hour traffic volumes. Exhibit 61 shows that five steps are used to assess the sufficiency of intersection capacity based on the  $v/c$  ratio.

##### Step 1: Determine the Left-Turn Phasing

The left-turn phasing can be permitted, protected, protected plus permitted, or split.

- *Permitted phasing* allows left-turn movements to proceed when gaps in traffic permit.
- *Protected phasing* provides a left-turn arrow that allows left turns to proceed without conflicts.
- *Protected plus permitted* phasing provides both a protected and a permitted phase.

**Exhibit 61. Intersection capacity sufficiency analysis steps.**

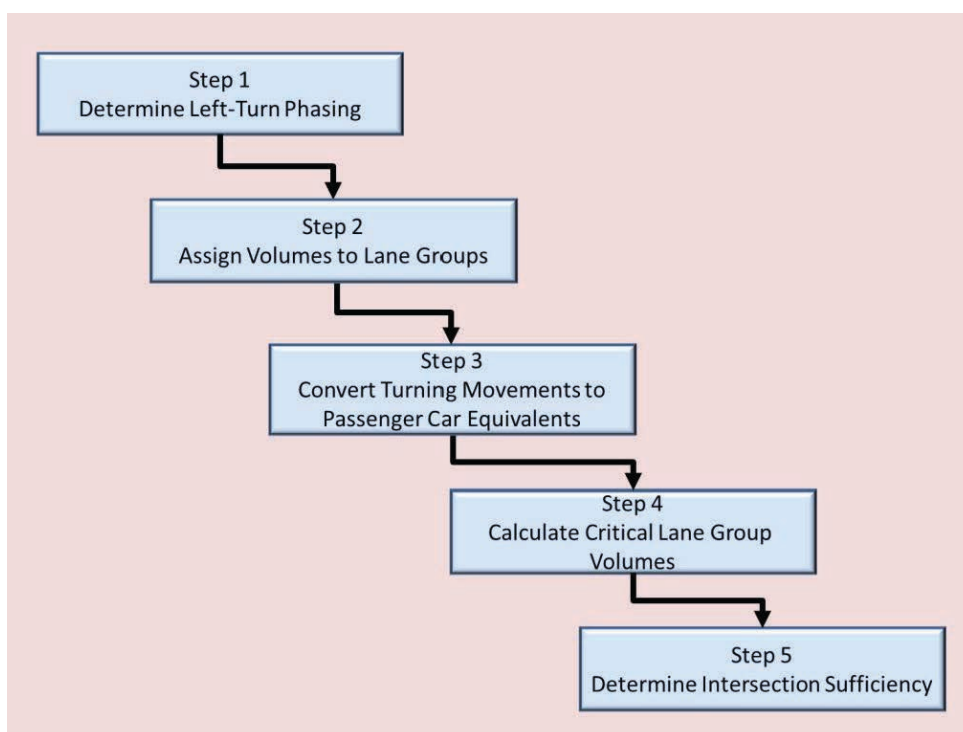

- *Split phasing* means that all movements on an approach, including the left turns, proceed at the same time with no opposing movements.

The analyst can select one of these four phasing types if the phasing is known. If it is not known, the computational procedure will determine the left-turn phasing. The method will select protected left-turn phasing if any of the following three conditions are met; otherwise, permitted left-turn phasing will be selected:

- Left-turn volume exceeds 240 veh/h;
- The product of the left-turn volume and the opposing through volume exceeds a given threshold (50,000 if there is one opposing through lane, 90,000 if there are two opposing through lanes, and 110,000 if there are three or more opposing through lanes); or
- The number of left-turn lanes exceeds one.

If both opposing approaches have exclusive left-turn lanes, and one of those meets the above thresholds for left-turn protection, then both approaches will have left-turn protection.

## Step 2: Identify Lane Groups

A lane group is a lane or set of lanes designated for separate analysis. All traffic movements for a given approach (i.e., left, through, and right) must be assigned to a lane group. A lane group can consist of one or more lanes. There are two guidelines for assigning traffic movements to lane groups:

1. When a traffic movement uses only an exclusive lane(s), it is analyzed as an exclusive lane group.
2. When two or more traffic movements share a lane, all lanes which convey those traffic movements are analyzed as a mixed lane group.

When a right-turn movement is shared with a through movement, it is considered to be a part of the through movement lane group. When a right-turn movement is shared with a left-turn movement (such as at a T-intersection), it is considered to be a part of the left-turn movement lane group.

Lane groups should first be checked to determine if a de facto turn lane exists. A de facto turn lane occurs on approaches with multilane lane groups where either a left- or right-turn movement is shared with a through movement, but that lane is only used by turning vehicles. This occurs in situations where the turning movements are high, there are significant impedances for the turning movements, or both. In these situations, de facto turn lanes should be analyzed as exclusive turn lanes and all through movements should be assumed to occur from the through-only lane(s).

In cases where there are multiple turn lanes and one lane is shared with a through movement, that combination of lanes should be treated as a single-lane group and all the lanes should be associated with the through lane group. For approaches at a T-intersection where there are only left- and right-turn movements and multiple lanes, and one of the lanes is shared, the analyst has the option of coding all lanes as either the right-turn lane group or the left-turn lane group.

## Step 3: Convert Turning Movements to Through Passenger Car Equivalents

This step converts turning movements to through passenger car equivalents, considering the effect of heavy vehicles, variations in traffic flow during the hour, the impact of opposing through vehicles on permitted left-turning vehicles, the impact of pedestrians on right-turning vehicles, lane utilization, and the impact of parking maneuvers on through and right-turning vehicles.

**Step 3a: Heavy Vehicle Adjustment**

The adjustment for heavy vehicles  $E_{HVadj}$  is calculated using Equation 75.

$$E_{HVadj} = 1 + P_{HV} (E_{HV} - 1) \tag{Equation 75}$$

where

- $E_{HVadj}$  = heavy vehicle adjustment factor (unitless),
- $P_{HV}$  = proportion of heavy vehicles in the movement (decimal), and
- $E_{HV}$  = passenger car equivalent for heavy vehicles in the movement (default = 2.0).

**Step 3b: Peak Hour Factor Adjustment**

The adjustment for variation in flow during the peak hour is calculated using Equation 76.

$$E_{PHF} = \frac{1}{PHF} \tag{Equation 76}$$

where

- $E_{PHF}$  = flow variation adjustment factor (unitless), and
- $PHF$  = peak hour factor (unitless, ranges from 0.25 to 1.00, default = 0.92).

**Step 3c: Turn Impedance Adjustment**

The turn impedance adjustment factors  $E_{LT}$  and  $E_{RT}$  adjust for impedances experienced by left- and right-turning vehicles, respectively. Left-turning vehicles served by permitted left-turn phasing must find acceptable gaps in the opposing through traffic stream to complete their turns. Left-turning vehicles served by protected left-turn phasing also flow more slowly than through vehicles. The methods used to determine  $E_{LT}$  and  $E_{RT}$  depend on the signal phasing used for the turns. Through vehicles do not experience the impedances that turning vehicles do, so the flows for these movements are not adjusted.

**Permitted Left-Turn Phasing.** The values for  $E_{LT}$  for permitted left turns are given in Exhibit 62.

**Protected and Split Left-Turn Phasing.** If the left turn is protected, or uses split phasing, then  $E_{LT} = 1.05$  regardless of volume.

**Protected-Permitted Left-Turn Phasing.** Equation 77 is used to calculate  $E_{LT}$  when protected-permitted phasing is used. The signal timing must be known or estimated by the analyst. Note that the effective green time for the first portion of the protected-permitted phase includes the yellow interval between the two portions.

**Exhibit 62. Left-turn impedance adjustment factor  $E_{LT}$  values for permitted left turns.**

Opposing Through and Right-Turn Volumes (veh/h)	$E_{LT}$
<200	1.10
200–599	2.00
600–799	3.00
800–999	4.00
≥1,000	5.00

$$E_{LT} = \frac{(E_{LT,prot} g_{LT,prot})(E_{LT,perm} g_{LT,perm})}{g_{LT,prot} + g_{LT,perm}} \tag{Equation 77}$$

where

- $E_{LT}$  = left-turn impedance adjustment factor (unitless),
- $E_{LT,prot}$  = left-turn impedance adjustment factor for the protected portion of the left-turn phase (unitless) = 1.05,
- $E_{LT,perm}$  = left-turn impedance adjustment factor for the permitted portion of the left-turn phase (unitless),
- $g_{LT,prot}$  = effective green time for the protected portion of the left-turn phase (s), and
- $g_{LT,perm}$  = effective green time for the permitted portion of the left-turn phase (s).

**Permitted Right-Turn Phasing.** Right-turning vehicles are sometimes impeded by pedestrians. The values for  $E_{RT}$  for permitted right turns are given in Exhibit 63.

**Protected and Split Right-Turn Phasing.** When protected right turns are provided, the  $E_{RT}$  value for “none or low” pedestrian activity in Exhibit 63 (1.2) should be used.

**Step 3d: Parking Adjustment Factor**

The parking adjustment factor  $E_p$  is a function of the presence of on-street parking and applies to through and right-turn volumes. Values for  $E_p$  are given in Exhibit 64.

**Step 3e: Lane Utilization Factor**

The lane utilization factor  $E_{LU}$  recognizes the volume imbalance between lanes when there are two or more lanes on an approach. Values for this factor are given in Exhibit 65.

**Step 3f: Adjustment Factor for Other Effects**

The analyst may wish to incorporate the saturation flow rate effects of work zones (if any), mid-segment lane blockage, and sustained spillback from downstream segment in a comprehensive volume adjustment factor for other effects  $E_{other}$ . The analyst should consult the HCM for

**Exhibit 63. Right-turn impedance adjustment factor  $E_{RT}$  values for permitted right turns.**

Pedestrian Activity	$E_{RT}$
None or low	1.20
Medium	1.30
High	1.50
Very high	2.10

**Exhibit 64. Parking adjustment factor  $E_p$ .**

Parking Activity	Number of Lanes in Lane Group	$E_p$
No parking lane	All	1.00
	1	1.20
	2	1.10
Adjacent parking	2	1.10
	3	1.05



**Exhibit 65. Lane utilization factor  $E_{LU}$ .**

Lane Group Movements	No. of Lanes in Lane Group	$E_{LU}$
Through or shared	1	1.00
	2	1.05
	≥3	1.10
Exclusive LT	1	1.00
	≥2	1.03
Exclusive RT	1	1.00
	≥2	1.13

guidance on the magnitude of these other effects on saturation flow rates. The default value for  $E_{other}$  is 1.00 (i.e., no other effects).

**Step 3g: Through Passenger Car Equivalent Flow Rate**

The through passenger car equivalent flow rate  $v_{adj}$  is calculated using Equation 78, applying the adjustment factors determined in Steps 3a through 3f.

$$v_{adj} = VE_{HVadj}E_{PHF}E_{LT}E_{RT}E_pE_{LU}E_{other} \tag{Equation 78}$$

where

- $v_{adj}$  = through passenger car equivalent flow rate (through passenger cars per hour, tpc/h),
- $V$  = turning-movement volume (veh/h),
- $E_{HVadj}$  = heavy vehicle adjustment factor (unitless),
- $E_{PHF}$  = flow variation adjustment factor (unitless),
- $E_{LT}$  = left-turn impedance adjustment factor (unitless),
- $E_{RT}$  = right-turn impedance adjustment factor (unitless),
- $E_p$  = parking adjustment factor (unitless),
- $E_{LU}$  = lane utilization adjustment factor (unitless), and
- $E_{other}$  = adjustment factor to account for other conditions determined by the analyst (unitless).

**Step 3h: Equivalent Per-Lane Flow Rate**

Finally, the equivalent per-lane flow rate  $v_i$  for a given lane group  $i$  is calculated using Equation 79.

$$v_i = \frac{v_{adj,i}}{N_i} \tag{Equation 79}$$

where

- $v_i$  = equivalent per-lane flow rate for lane group  $i$  (tpc/h/ln),
- $v_{adj,i}$  = through passenger car equivalent flow rate for lane group  $i$  (tpc/h), and
- $N_i$  = number of lanes within lane group  $i$ , accounting for de facto lanes.

**Step 4: Calculate Critical Lane Group Volumes**

Critical lane groups represent the combination of conflicting lane groups from opposing approaches that have the highest total demand. These critical lanes groups thus dictate the amount of green time required during each phase as well as the total cycle length required for the intersection. The movements and phasing for the north–south and east–west approaches are

assessed independently. The combination of movements that make up the critical movements are different for protected and permitted left-turn phasing, and for split phasing.

#### Step 4a: Identify Critical Movements

**Protected Left-Turn Phasing.** When opposing approaches use protected left-turn phasing, the critical lane group volumes will be the maximum of the two sums of the left-turn lane volume and the opposing through (or shared through) lane volume, or right-turn lane volume if that is greater. For the east–west approaches, the critical lane group volume  $V_{c,EW}$  is calculated using Equation 80.

$$v_{c,EW} = \max \begin{cases} v_{EBLT} + \max(v_{WBTH}, v_{WBRT}) \\ v_{WBLT} + \max(v_{EBTH}, v_{EBRT}) \end{cases} \quad \text{Equation 80}$$

where

$V_{c,EW}$  = critical east–west lane group volume (tpc/h/ln),  
 $v_{EBLT}$  = equivalent flow rate for the eastbound left-turn lane group (tpc/h/ln),  
 $v_{EBTH}$  = equivalent flow rate for the eastbound through lane group (tpc/h/ln),  
 $v_{EBRT}$  = equivalent flow rate for the eastbound right-turn lane group (tpc/h/ln),  
 $v_{WBLT}$  = equivalent flow rate for the westbound left-turn lane group (tpc/h/ln),  
 $v_{WBTH}$  = equivalent flow rate for the westbound through lane group (tpc/h/ln), and  
 $v_{WBRT}$  = equivalent flow rate for the westbound right-turn lane group (tpc/h/ln).

Similarly for the north–south approaches, the critical volume  $V_{c,NS}$  is calculated using Equation 81.

$$v_{c,NS} = \max \begin{cases} v_{NBLT} + \max(v_{SBTH}, v_{SBRH}) \\ v_{SBLT} + \max(v_{NBTH}, v_{NBRH}) \end{cases} \quad \text{Equation 81}$$

where

$V_{c,NS}$  = critical north–south lane group volume (tpc/h/ln),  
 $v_{NBLT}$  = equivalent flow rate for the northbound left-turn lane group (tpc/h/ln),  
 $v_{NBTH}$  = equivalent flow rate for the northbound through lane group (tpc/h/ln),  
 $v_{NBRH}$  = equivalent flow rate for the northbound right-turn lane group (tpc/h/ln),  
 $v_{SBLT}$  = equivalent flow rate for the southbound left-turn lane group (tpc/h/ln),  
 $v_{SBTH}$  = equivalent flow rate for the southbound through lane group (tpc/h/ln), and  
 $v_{SBRH}$  = equivalent flow rate for the southbound right-turn lane group (tpc/h/ln).

**Permitted Left-Turn Phasing.** When opposing approaches use permitted phasing, the critical lane group volume will be the highest lane group volume of all lane groups for a pair of approaches. For the east–west approaches, the critical volume  $V_{c,EW}$  is calculated using Equation 82, while the critical volume for the north–south approaches  $V_{c,NS}$  is calculated using Equation 83.

$$v_{c,EW} = \max(v_{EBLT}, v_{EBTH}, v_{EBRT}, v_{WBLT}, v_{WBTH}, v_{WBRT}) \quad \text{Equation 82}$$

$$v_{c,NS} = \max(v_{NBLT}, v_{NBTH}, v_{NBRH}, v_{SBLT}, v_{SBTH}, v_{SBRH}) \quad \text{Equation 83}$$

where all variables are as defined previously.

**Split Phasing.** When opposing approaches use split phasing (where only one approach is served during the phase), the critical lane group volume will be the highest lane group volume

of all lane groups for that approach. For the east–west approaches, the critical volume  $V_{c,EW}$  will be the sum of:

$$V_{c,EW} = \max(v_{EBLT}, v_{EBTH}, v_{EBRT}) + \max(v_{WBLT}, v_{WBTH}, v_{WBRT}) \quad \text{Equation 84}$$

where all variables are as defined previously. Similarly, for the north–south approaches with split phasing, the critical volume  $V_{c,NS}$  will be the sum of:

$$V_{c,NS} = \max(v_{NBLT}, v_{NBTH}, v_{NBRT}) + \max(v_{SBLT}, v_{SBTH}, v_{SBRT}) \quad \text{Equation 85}$$

where all variables are as defined previously.

**Protected-Permitted Left-Turn Phasing.** The signal timing must be known or estimated by the analyst, which would have been done as part of Step 3c. To find the critical lane group volumes, the equivalent through-car volume in the left lane during the protected portion of the phase is found using Equation 86 by splitting the total demand in proportion to the length of the protected portion of the phase to the overall protected-permitted phase.

$$V_{LT,prot} = V_{LT} \left( \frac{g_{LT,prot}}{g_{LT,prot} + g_{LT,perm}} \right) \quad \text{Equation 86}$$

where

- $V_{LT,prot}$  = left-turn demand during the protected portion of the phase (tpc/h/ln),
- $V_{LT}$  = overall left-turn demand during the left-turn phase (tpc/h/ln),
- $g_{LT,prot}$  = effective green time for the protected portion of the left-turn phase (s), and
- $g_{LT,perm}$  = effective green time for the permitted portion of the left-turn phase (s).

The critical lane volumes are then found using only the protected portion of the compound phase. The critical lane group volume is the highest total of a through lane volume and its opposing protected left-turn volume. The remainder of the methodology does not change. In the delay module (optional Step 7), the overall left-turn demand  $V_{LT}$  is used to find delay.

#### **Step 4b: Calculate the Sum of the Critical Lane Volumes**

The sum of the critical lane volumes  $V_c$  is calculated using Equation 87.

$$V_c = V_{c,EW} + V_{c,NS} \quad \text{Equation 87}$$

where

- $V_c$  = critical intersection volume (tpc/h/ln),
- $V_{c,EW}$  = critical east–west volume (tpc/h/ln), and
- $V_{c,NS}$  = critical north–south volume (tpc/h/ln).

### **Step 5: Determine Intersection Sufficiency**

#### **Step 5a: Calculate the Critical Volume-to-Capacity Ratio**

The critical volume-to-capacity ratio  $X_c$  is calculated using Equation 88.

$$X_c = \frac{V_c}{C_i} \quad \text{Equation 88}$$

**Exhibit 66. Intersection sufficiency.**

$X_c$	Description	Capacity Assessment
<0.85	All demand is able to be accommodated; delays are low to moderate.	Under
0.85–0.98	Demand for critical lane groups near capacity and some movements require more than one cycle to clear the intersection; all demand is able to be processed at the end of the analysis period; delays are moderate to high.	Near
>0.98	Demand for critical movements is just able to be accommodated within a cycle but more oftentimes requires multiple cycles to clear the intersection; delays are high and queues are long.	Over

where

$X_c$  = critical volume-to-capacity ratio (unitless),

$V_c$  = critical intersection volume (tpc/h/ln), and

$c_i$  = intersection capacity (tpc/h/ln).

Intersection capacity is the maximum per-lane through movement flow rate that can be accommodated by the intersection, accounting for lost time. A value of 1,650 tpc/h/ln can be used as a default if local data are not known. This value reflects a saturation flow rate of 1,900 tpc/h/ln, a lost time of 4 seconds per critical phase, and a cycle length of 30 seconds per critical phase. A value of 1,500 tpc/h/ln may be used for signalized intersection capacity in smaller urban areas (under 250,000 population). Higher values may be appropriate for suburban or rural signals with high-speed approaches ( $\geq 45$  mph).

**Step 5b: Assess the Intersection Sufficiency**

The final step of the  $v/c$  analysis is to assess the sufficiency of the intersection to accommodate a given demand level. Exhibit 66 provides the assessment of intersection sufficiency (under, near, or over) based on the critical volume-to-capacity ratio.

## 5. Simplified Method, Part 2: Delay, LOS, and Queue Calculation

Part 2 of the method includes four steps and produces estimates of delay, LOS, and queue. It applies the results from Part 1. The steps are shown in Exhibit 67 and are described herein.

**Step 6: Calculate Capacity**
**Step 6a: Calculate Cycle Length**

The traffic signal cycle length  $C$  is assumed to be 30 seconds per critical phase. The analyst can use another value based on local practice or conditions.

$$C = 30n$$

Equation 89

where

$C$  = traffic signal cycle length (s), and

$n$  = number of critical phases.

**Exhibit 67. Signalized intersection planning method, part 2.**

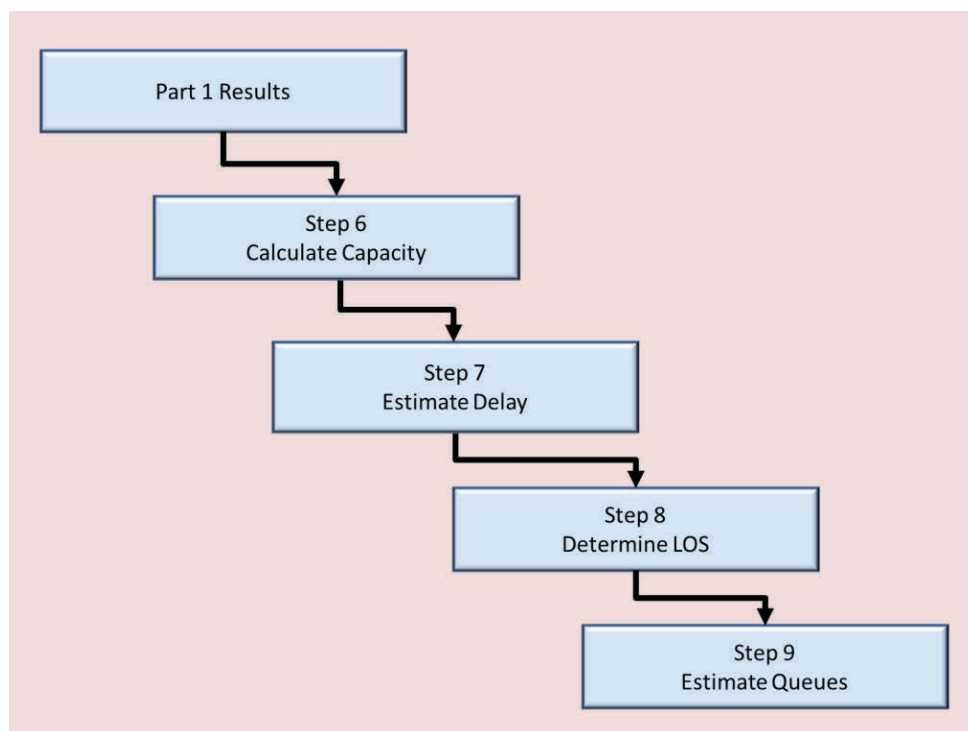

**Step 6b: Calculate the Total Effective Green Time**

The total effective green time  $g_{TOT}$  available during the cycle is calculated using Equation 90.

$$g_{TOT} = C - L \tag{Equation 90}$$

where

- $g_{tot}$  = total effective green time (s),
- $C$  = traffic signal cycle length (s), and
- $L$  = lost time per cycle (s) (default = 4 seconds per critical phase).

The total effective green time is then allocated to each critical phase in proportion to the critical lane group volume for that movement using Equation 91:

$$g_i = g_{TOT} \left( \frac{V_{ci}}{V_c} \right) \tag{Equation 91}$$

where

- $g_i$  = effective green time for phase  $i$  (s),
- $g_{tot}$  = total effective green time (s),
- $V_{ci}$  = critical lane group volume for phase  $i$  (tpc/h/ln), and
- $V_c$  = critical intersection volume (tpc/h/ln).

For the non-critical phase (and the movements served by these phases), the effective green time is set equal to the green time for the phase on the opposing approach that serves the same directional movement. The green time for each phase should be reviewed against policy

requirements and other considerations such as the minimum green time and the time required for pedestrians to cross the approach. All green time and cycle length calculations should be adjusted to meet minimum requirements for all users.

### Step 6c: Calculate Capacity and Volume-to-Capacity Ratio

The capacity  $c_i$  and volume-to-capacity ratio  $X_i$  for each lane group  $i$  are calculated using Equation 92 and Equation 93.

$$c_i = \text{BaseSat} \left( \frac{g_i}{C} \right) \quad \text{Equation 92}$$

$$x_i = \frac{v_i}{c_i} \quad \text{Equation 93}$$

where

- $c_i$  = capacity of lane group  $i$  (tpc/h/ln),
- $v_i$  = volume for lane group  $i$  (tpc/h/ln),
- $\text{BaseSat}$  = 1,900 for large urban areas (over 250,000 population) and 1,750 otherwise (pc/h/ln),
- $g_i$  = effective green time for lane group  $i$  (s), and
- $C$  = traffic signal cycle length (s).

For the intersection as a whole, the critical degree of saturation  $X_c$  is calculated using Equation 94 and Equation 95.

$$X_c = \frac{\sum_{i=1}^n v_{ci}}{c_{\text{SUM}}} \quad \text{Equation 94}$$

$$c_{\text{SUM}} = 1,900 \left( \frac{\sum_{i=1}^n g_{ci}}{C} \right) \quad \text{Equation 95}$$

where

- $X_c$  = critical degree of saturation (unitless),
- $v_{ci}$  = volume for critical phase  $i$  (tpc/h/ln),
- $c_{\text{SUM}}$  = intersection capacity (tpc/h/ln),
- $g_{ci}$  = effective green time for critical phase  $i$  (s), and
- $C$  = traffic signal cycle length (s).

### Step 7: Estimate Delay

The control delay for each lane group  $d_i$  is calculated using Equation 96.

$$d_i = d_1 PF + d_2 + d_{\text{unsig}} \quad \text{Equation 96}$$

where

- $d_i$  = control delay for lane group  $i$  (s/veh),
- $d_1$  = uniform delay (s/veh),
- $PF$  = progression adjustment factor (unitless),
- $d_2$  = incremental delay (s/veh), and
- $d_{\text{unsig}}$  = analyst-provided estimate of unsignalized movement delay, if any (s/veh).

**Exhibit 68. Progression adjustment factor.**

Progression Quality	Progression Factor <i>PF</i>
<b>Good</b> (some degree of coordination between the two signalized intersections)	0.70
<b>Average</b> (random arrivals)	1.00
<b>Poor</b> (poor coordination between the intersections)	1.25

The unsignalized movement delay  $d_{unsig}$  is the average delay (if any) for turns at the intersection that are not controlled by a signal head. This delay is usually zero but may be non-zero for situations such as a STOP-controlled channelized right-turn lane. It may also be non-zero for alternative intersection concepts, such as Michigan U-turns and others.

The uniform delay  $d_1$  is calculated using Equation 97.

$$d_1 = \frac{0.5C(1 - g/C)^2}{1 - [\min(1, X)(g/C)]} \tag{Equation 97}$$

where

- $d_1$  = lane group uniform delay (s/veh),
- $C$  = traffic signal cycle length (s),
- $g/C$  = lane group effective green ratio (unitless), and
- $X$  = lane group volume-to-capacity ratio (unitless).

The progression factor *PF* is given in Exhibit 68 and is selected based on the quality of progression from an upstream signalized intersection. Possible values for the progression factor are 0.70 if the quality of progression is good and 1.25 if the quality is poor. The default value is 1.00 if progression is average, indicating that vehicles arrive in a random manner.

The incremental delay  $d_2$  is calculated as follows:

$$d_2 = 225 \left[ (X - 1) + \sqrt{(X - 1)^2 + \frac{16X}{c}} \right] \tag{Equation 98}$$

where

- $d_2$  = lane group incremental delay (s/veh),
- $X$  = lane group volume-to-capacity ratio (unitless), and
- $c$  = lane group capacity (tpc/h/ln).

**Step 8: Determine LOS**

The LOS for each lane group or for the intersection as a whole is given in Exhibit 69 on the basis of average control delay. Note that if the volume-to-capacity ratio exceeds 1.0, then the LOS will be F regardless of the control delay.

**Step 9: Estimate Queues**

The deterministic average queue for each lane group (i.e., the average queue at the end of red) is determined by dividing the average uniform delay for that lane group by the capacity for that lane group.

**Exhibit 69. Level of service for signalized intersections.**

Control Delay (s/veh)	LOS
≤10	A
>10–20	B
>20–35	C
>35–55	D
>55–80	E
>80 or $X > 1.00$	F

Source: Adapted from HCM (2016), Exhibit 19-8.

Note:  $X$  = volume-to-capacity ratio.

$$Q = \frac{d_1 \times c}{3,600} \tag{Equation 99}$$

where

- Q = deterministic average queue for the lane group (tpc/l<sub>n</sub>),
- d<sub>1</sub> = uniform delay for the lane group (s), and
- c = per-lane capacity of the lane group (tpc/h/l<sub>n</sub>).

The deterministic average queue for the lane group does not take into account random bunching of traffic arrivals within the analysis period. The deterministic average queue may be multiplied by 2.0 (approximately the ratio of the 95th percentile to the mean for a Poisson process) to obtain an approximation of the 95th percentile longest queue likely to be observed during a traffic signal cycle.

Equation 99 only applies when the lane group operates under capacity, and, on average, the queue is able to fully dissipate each cycle. When a lane group operates over capacity, the difference between the lane group demand and the lane group capacity, divided by the number of lanes in the lane group, provides the number of vehicles per lane not served (i.e., in queue) at the end of the analysis hour.

## 6. Worksheets

The worksheets provided as Exhibit 70 through Exhibit 73 illustrate how the computations might be laid out in a spreadsheet.

## 7. Reliability Analysis

The HCM 2016 does not provide a method for estimating the variability of delay at a signal-controlled intersection. The analyst might perform a sensitivity analysis by repeating the planning computations using the 25th percentile and 75th percentile highest demands of the year and the 25th percentile and 75th percentile highest capacities of the year (taking into account incidents) and report the results in a table such as shown in Exhibit 74.

**Exhibit 70. Signalized intersection planning method (Part 1), input worksheet.**

Signalized Intersection Planning Method (Part 1), Inputs												
	NB			SB			EB			WB		
	LT	TH	RT	LT	TH	RT	LT	TH	RT	LT	TH	RT
Volume												
Lanes												
PHF												
% HV												
Parking activity												
Ped activity												
LT phasing												

Notes: NB = northbound, SB = southbound, EB = eastbound, WB = westbound, LT = left turn, TH = through, RT = right turn, PHF = peak hour factor, and HV = heavy vehicles.



**Exhibit 71. Signalized intersection planning method (Part 1), calculations worksheet.**

Signalized Intersection Planning Method (Part 1), Calculations												
	NB			SB			EB			WB		
	LT	TH	RT	LT	TH	RT	LT	TH	RT	LT	TH	RT
<b>Step 1: Determine the Left-Turn Phasing</b>												
Check #1												
Check #2												
Check #3												
LT phasing												
<b>Step 2: Assign Volumes to Lane Groups</b>												
$V_i$												
<b>Step 3: Convert Turning Movements to Passenger Car Equivalents</b>												
$E_{HVadj}$												
$E_{PHF}$												
$E_{LT}$												
$E_{RT}$												
$E_P$												
$E_{LU}$												
$V_{adj}$												
<b>Step 4: Calculate Critical Lane Groups</b>												
$VC_{EW}$												
$VC_{NS}$												
$V_c$												
<b>Step 5: Determine Intersection Sufficiency</b>												
$v_c/c_i$												
Intersection sufficiency												

Notes: NB = northbound, SB = southbound, EB = eastbound, WB = westbound, LT = left turn, TH = through, RT = right turn.

**Exhibit 72. Signalized intersection planning method (Part 2), calculations worksheet.**

Signalized Intersection Planning Method (Part 2), Calculations												
	NB			SB			EB			WB		
	LT	TH	RT	LT	TH	RT	LT	TH	RT	LT	TH	RT
<b>Step 6: Calculate Capacity</b>												
$C$												
$L$												
$g_{TOT}$												
$v_{ci}$												
$v_c$												
$g_i$												
$c_i$												
$X_{ij}$												
$C_{SUM}$												
$X_c$												
<b>Steps 7 and 8: Estimate Delay and Level of Service</b>												
$d_1$												
$d_2$												
$PF$												
$d$												
LOS												
$d$ (int.)												
LOS (int.)												

Notes: NB = northbound, SB = southbound, EB = eastbound, WB = westbound, LT = left turn, TH = through, RT = right turn, int. = intersection.

**Exhibit 73. Signalized intersection planning method, protected-permitted left-turn worksheet.**

Signalized Intersection Planning Method, Protected-Permitted Left-Turn Worksheet				
	NB	SB	EB	WB
$g_{LTPT}$				
$g_{LTPM}$				
$E_{LTPT}$				
$E_{LTPM}$				
$E_{LTC}$				
$V_{LTTOT}$				
$V_{LTPT}$				

Notes: NB = northbound, SB = southbound, EB = eastbound, WB = westbound.

**Exhibit 74. Example sensitivity analysis table for signalized intersection reliability.**

Capacity (veh/h)	Percentile Demand (veh/h)		
	25th	Median (50th)	75th
25th percentile			
50th percentile (median)			
75th percentile			

Note: Table is intentionally blank. Entries would be average delays in seconds per vehicle.

## 8. Multimodal LOS

### Bicycle and Pedestrian LOS

Procedures for evaluating bicycle and pedestrian LOS at signalized intersections are provided in Section O5.

### Transit LOS (No Method Available)

The HCM does not provide procedures for assessing transit LOS at signalized intersections. Instead, transit LOS is measured at the urban segment and facility levels, with the measure incorporating the effects of traffic signal delay on overall transit speed.

### Truck LOS (No Method Available)

The HCM does not provide a truck LOS measure for signalized intersections.

## 9. Example

Case Study 2 (Section U in the Guide) provides an example application of the screening and simplified analysis methods described in this section.

## 10. Reference

*Highway Capacity Manual: A Guide to Multimodal Mobility Analysis*. 6th ed. Transportation Research Board, Washington, D.C., 2016.



# M. STOP-controlled Intersections

## 1. Overview

STOP-controlled intersections may be all-way STOP-controlled or partially STOP-controlled. A two-way STOP intersection is an example of a partially STOP-controlled intersection. Neither the HCM nor this Guide provides a method for intersections that falls between two-way and all-way STOP control (e.g., four-legged intersections where three legs are STOP-controlled).

A two-way STOP-controlled (TWSC) intersection is an intersection in which the movements on one street (the *minor street*) are controlled by STOP signs, while the movements on the other street (the *major street*) are not STOP-controlled. An all-way STOP-controlled intersection (AWSC) intersection is one where all movements are STOP-controlled.

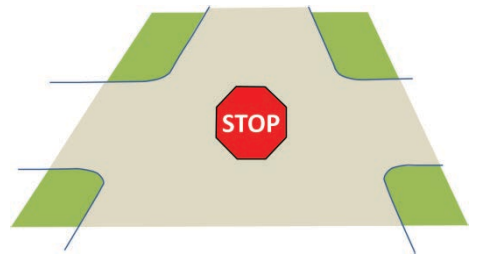

## 2. Applications

The procedures in this section are designed to support the following planning and preliminary engineering analyses:

- Feasibility studies of intersection improvements, and
- Land development traffic impact studies.

## 3. Analysis Methods Overview

Intersection performance can be directly measured in the field or it can be estimated in great detail using microsimulation. However the resource requirements of both of these methods render them generally impractical for most planning and preliminary engineering applications.

HCM Chapters 20 and 21 provide a much less resource-intensive approach to estimating intersection performance; however, it is generally impractical to use the HCM methods with 100 percent field-measured inputs for many planning and preliminary engineering analyses. Employing the HCM methods with the defaults identified in HCM Chapters 20 and 21 reduces the data requirements, but still requires specialized software to implement the complex computations.

This section presents a simplified HCM medium-level method for evaluating all-way and two-way STOP-controlled intersections, as indicated by the unshaded boxes in Exhibit 75. The data needs, assumptions, and limitations of each analysis approach are described as part of the procedures for each approach.

**Exhibit 75. Analysis options for STOP-controlled intersections.**

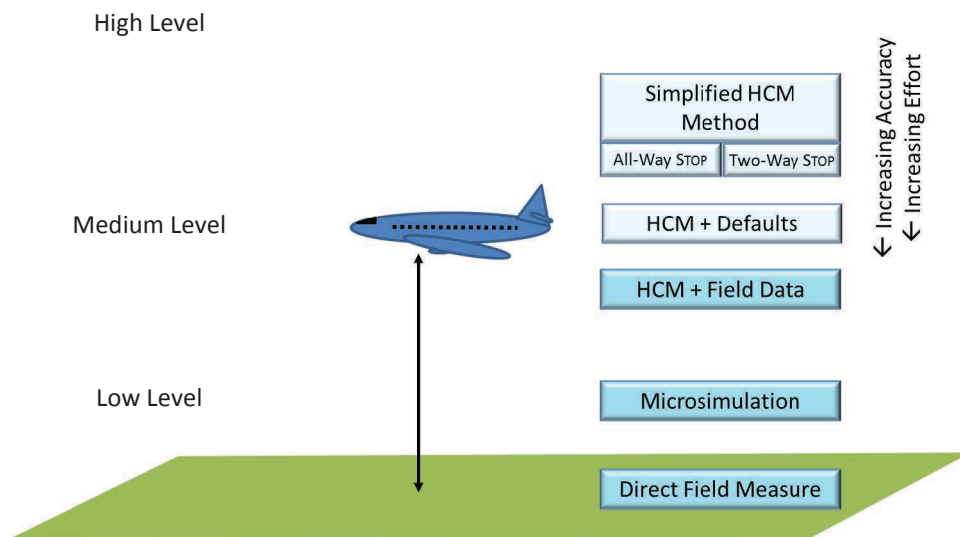

#### 4. Simplified HCM Method for All-Way STOP-controlled Intersections

An AWSC intersection is an intersection in which all movements are STOP-controlled. The operational analysis method for AWSC intersections, described in HCM Chapter 21, uses an iterative approach to calculate the delay on one approach of the intersection, based on the flow rate on that approach and the flow rates on the other approaches. The method is complex enough to require a computational engine to produce the predictions of delay for even the most basic conditions.

The planning method for AWSC intersections is based on the HCM operational analysis method. The method predicts the delay for each intersection approach and for the intersection. Because of the computational complexity of the operational analysis method, the planning method is presented in a series of figures from which the analyst can determine the approach delay and the intersection delay based on the volumes of the two intersecting streets and the number of lanes on each approach.

#### Assumptions, Limitations, and Input Requirements

The following assumptions are made in applying the planning method for AWSC intersections:

- There are no pedestrians at the intersection,
- There are one or two lanes on each approach,
- Opposite approaches (e.g., north and south) have the same number of lanes, and
- Turning movements account for 20 percent of the traffic on each approach.

The AWSC intersection planning method requires two inputs. The analyst is required to specify values for the volume for each movement (in vehicles per hour) and the number of lanes on each approach.

#### Volume-to-Capacity Ratio Estimation

For the purposes of computing approximate volume-to-capacity ratios for the intersection, Exhibit 76 can be used. The capacity available to any single approach depends on how much capacity is consumed by the other approaches.

**Exhibit 76. Total entering capacity for AWSC intersections.**

Number of Lanes		Total Entering Capacity, All Approaches (veh/h)
Street 1 Approach	Street 2 Approach	
1	1	1,200
1	2	1,500
2	2	1,800

Source: Adapted from HCM (2016), Equation 21-14.

Note: Assumes average adjusted headways of 3 seconds for single-lane approaches, and two-lane approaches increase capacity by 50%.

### Delay Estimation

The delay on each approach of an AWSC intersection is estimated by entering the Street 1 (subject approach) approach volume and the higher of the Street 2 (cross street) approach volumes in Exhibit 77 for a single-lane approach, or by using Exhibit 78 for an approach with two or more lanes. The delay for the Street 1 volume is then read on the graph's y-axis.

The average intersection delay is then computed by taking a weighted average of the approach delays.

$$d = \frac{\sum v_i \times d_i}{\sum v_i} \tag{Equation 100}$$

where

- $d$  = average intersection delay (s/veh),
- $v_i$  = volume on approach  $i$  (veh/h), and
- $d_i$  = delay on approach  $i$  (s/veh).

**Exhibit 77. AWSC intersection planning method, street 1 delay, 20% turns, one-lane approaches.**

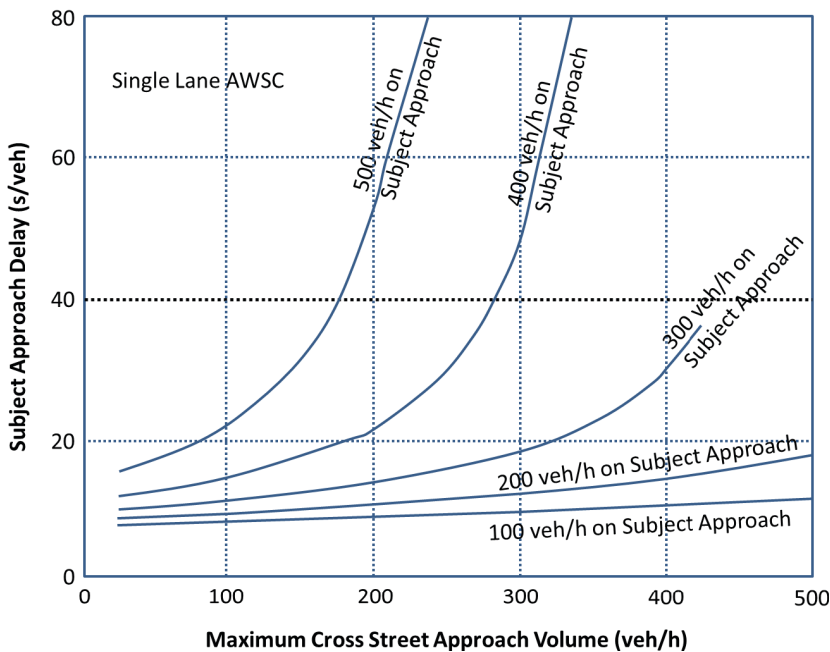

**Exhibit 78. AWSC intersection planning method, street 1 delay, 20% turns, two-lane approaches.**

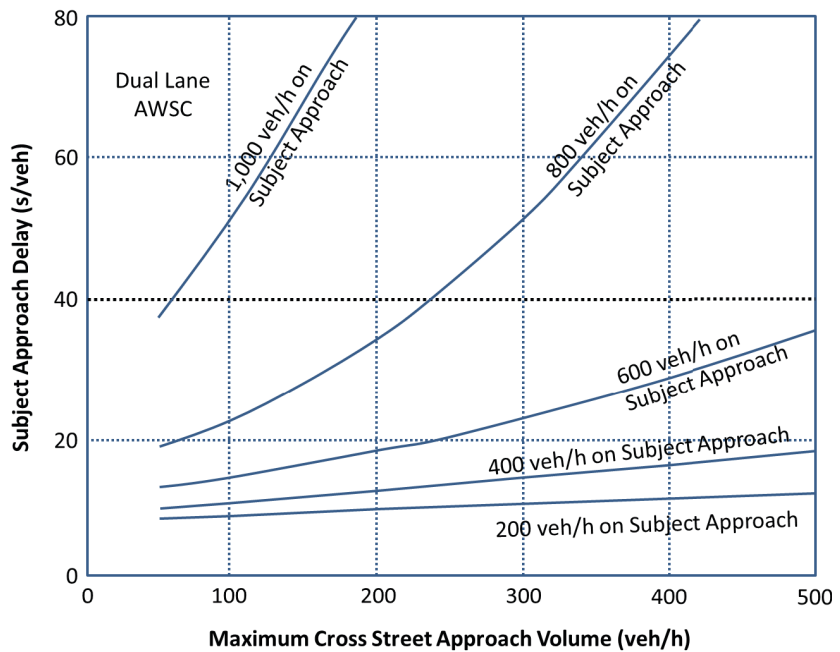

## 5. Simplified HCM Method for Two-Way Stop-controlled Intersections

A TWSC intersection is an intersection where the movements on one street (the *minor street*) are controlled by STOP signs, while the movements on the other street (the *major street*) are not STOP-controlled. The planning method for TWSC intersections is based on the operational analysis method described in HCM Chapter 20.

The TWSC intersection planning method predicts the capacity and delay for all minor-stream movements at a TWSC intersection. The method estimates the capacity of a minor-stream movement based on the conflicting flows of higher-priority traffic streams, and the critical headway and follow-up headway of the minor traffic stream.

### Assumptions, Limitations, and Data Requirements

The planning method for TWSC intersections has the following assumptions and limitations:

- No pedestrians at the intersection;
- No median on the major street;
- Left turns and through movements must be made in one step;
- Random vehicle arrivals on the major street, with no platooning from upstream traffic signals;
- Exclusive left-turn lane(s) provided on the major street;
- No short right-turn lanes are provided; and
- No U-turns occur.

The TWSC intersection planning method requires four inputs:

- Demand volumes  $V_i$  (veh/h) for each movement;
- Proportion of heavy vehicles  $P_{HV}$  for each movement;
- Number of lanes (and the turn designation for each) on each approach; and

- Intersection peak hour factor *PHF* for the intersection, either supplied by the analyst or assuming a default value of 0.92.

If only approach volumes are known, one of the methods described in Section D8 can be used to generate demand volumes by movement.

### Capacity Estimation

The method uses eight steps to estimate capacity, as shown in Exhibit 79 and described herein.

#### Step 1: Determine and Label Movements and Priorities

Movements and priorities are determined and labeled using the numbering scheme from Exhibit 80. The movements are ranked according to the following priorities:

- Rank 1 movements are the major street through movements (movements 2 and 5) and major street right turns (3 and 6),
- Rank 2 movements are the major street left turns (1 and 4) and the minor street right turns (9 and 12),
- Rank 3 movements are the minor street through movements (8 and 11), and
- Rank 4 movements are the minor street left turns (7 and 10).

#### Step 2: Convert Movement Demand to Flow Rates

Movement demand volumes are converted to flow rates using Equation 101.

$$v_i = \frac{V_i}{PHF} \tag{Equation 101}$$

where

- $v_i$  = demand flow rate for movement *i* (veh/h)
- $V_i$  = demand volume for movement *i* (veh/h), and
- $PHF$  = peak hour factor (decimal, default = 0.92).

**Exhibit 79. TWSC intersection planning method, computational steps.**

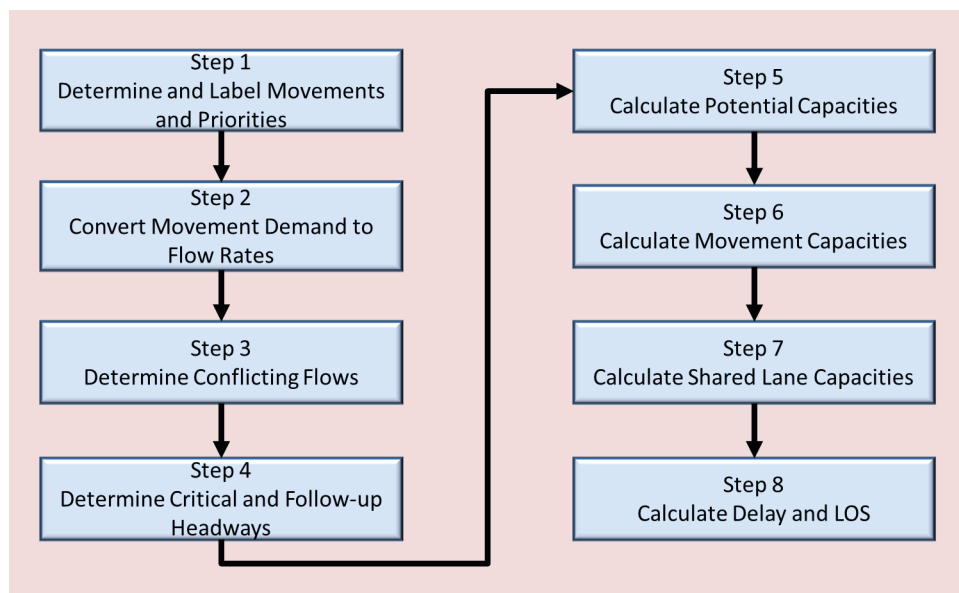

**Exhibit 80. Turning-movement numbering for TWSC intersections.**

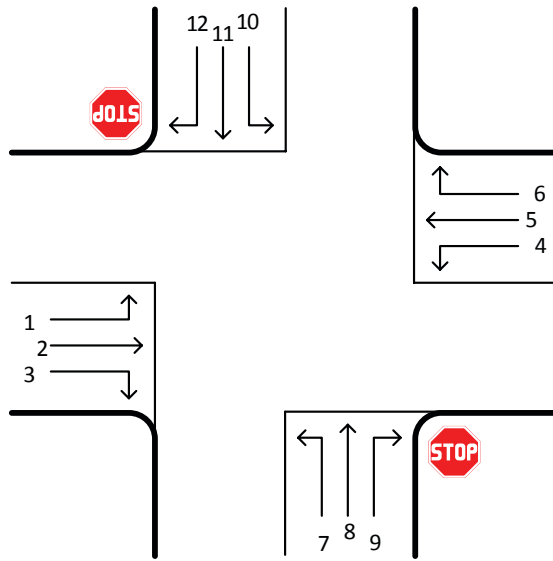

**Step 3: Determine Conflicting Flows**

Each non-rank 1 movement faces a unique set of conflicting flows through which the movement must maneuver. For example, a minor street through movement conflicts with one higher ranked movement (its opposing major street left-turn movement) while the minor street left turn conflicts with up to three higher ranked movements (the major street left turns, the opposing minor street through movement, and the opposing minor street right turns). The conflicting flows  $v_{c,x}$  for each movement are calculated using the equations herein. The demand flow rates  $v_i$ , where  $i$  ranges from 1 to 12 as shown in Exhibit 80, are the independent variables in these equations.

Conflicting flows for the major street left turns (movements 1 and 4) are calculated using Equation 102 and Equation 103:

$$v_{c,1} = v_5 + v_6 \tag{Equation 102}$$

$$v_{c,4} = v_2 + v_3 \tag{Equation 103}$$

where

$v_{c,1}, v_{c,4}$  = conflicting flow rates for movements 1 and 4, respectively (veh/h), and  
 $v_2, v_3, v_5, v_6$  = demand flow rates for movements 2, 3, 5, and 6, respectively (veh/h).

Conflicting flows for the minor street right turns (movements 9 and 12) are calculated using Equation 104 through Equation 107, depending on the number of lanes on the major street:

Two-lane major streets:  $v_{c,9} = v_2 + 0.5v_3$  Equation 104

$$v_{c,12} = v_5 + 0.5v_6 \tag{Equation 105}$$

Four- and six-lane major streets:  $v_{c,9} = 0.5v_2 + 0.5v_3$  Equation 106

$$v_{c,12} = 0.5v_5 + 0.5v_6 \tag{Equation 107}$$



where

$v_{c,9}, v_{c,12}$  = conflicting flow rates for movements 9 and 12, respectively (veh/h), and  
 $v_2, v_3, v_5, v_6$  = demand flow rates for movements 2, 3, 5, and 6, respectively (veh/h).

Conflicting flows for the minor street through movements (8 and 11) are calculated using Equation 108 and Equation 109:

$$v_{c,8} = 2v_1 + v_2 + 0.5v_3 + 2v_4 + v_5 + v_6 \quad \text{Equation 108}$$

$$v_{c,11} = 2v_4 + v_5 + 0.5v_6 + 2v_1 + v_2 + v_3 \quad \text{Equation 109}$$

where

$v_{c,8}, v_{c,11}$  = conflicting flow rates for movements 8 and 11, respectively (veh/h); and  
 $v_1, v_2, v_3, v_4, v_5, v_6$  = demand flow rates for movements 1, 2, 3, 4, 5, and 6, respectively (veh/h).

Conflicting flows for the minor street left turns (movements 7 and 10) are calculated using Equation 110 through Equation 115, depending on the number of lanes on the major street:

Two-lane major streets:  $v_{c,7} = 2v_1 + v_2 + 0.5v_3 + 2v_4 + v_5 + 0.5v_6 + 0.5v_{12} + 0.5v_{11}$  Equation 110

$$v_{c,10} = 2v_4 + v_5 + 0.5v_6 + 2v_1 + v_2 + 0.5v_3 + 0.5v_9 + 0.5v_8 \quad \text{Equation 111}$$

Four-lane major streets:  $v_{c,7} = 2v_1 + v_2 + 0.5v_3 + 2v_4 + 0.5v_5 + 0.5v_{11}$  Equation 112

$$v_{c,10} = 2v_4 + v_5 + 0.5v_6 + 2v_1 + 0.5v_2 + 0.5v_8 \quad \text{Equation 113}$$

Six-lane major streets:  $v_{c,7} = 2v_1 + v_2 + 0.5v_3 + 2v_4 + 0.4v_5 + 0.5v_{11}$  Equation 114

$$v_{c,10} = 2v_4 + v_5 + 0.5v_6 + 2v_1 + 0.4v_2 + 0.5v_8 \quad \text{Equation 115}$$

where

$v_{c,7}, v_{c,10}$  = conflicting flow rates for movements 7 and 10, respectively (veh/h); and

$v_1, v_2, v_3, v_4, v_5, v_6, v_8, v_9, v_{11}, v_{12}$  = demand flow rates for movements 1, 2, 3, 4, 5, 6, 8, 9, 11, and 12, respectively (veh/h).

**Step 4: Determine Critical and Follow-up Headways**

The critical headway  $t_{c,x}$  is calculated for each movement  $x$  as follows:

$$t_{c,x} = t_{c,base} + t_{c,HV}P_{HV} \quad \text{Equation 116}$$

where

- $t_{c,x}$  = critical headway for movement  $x$  (s),
- $t_{c,base}$  = base critical headway from Exhibit 81 (s),
- $t_{c,HV}$  = heavy vehicle adjustment factor (s) = 1.0 for major streets with one lane in each direction and 2.0 for major streets with two or three lanes in each direction, and
- $P_{HV}$  = proportion of heavy vehicles for movement (decimal).

**Exhibit 81. Base critical headways.**

Vehicle Movement	Number of Lanes on Major Street		
	2	4	6
Major street left turn (1, 4)	4.1	4.1	5.3
Minor street right turn (9, 12)	6.2	6.9	7.1
Minor street through movement (8, 11)	6.5	6.5	6.5
Minor street left turn (7, 10)	7.1	7.5	6.4

The follow-up headway  $t_{f,x}$  for each movement  $x$  is calculated using Equation 117.

$$t_{f,x} = t_{f,\text{base}} + t_{f,HV} P_{HV} \quad \text{Equation 117}$$

where

- $t_{f,x}$  = follow-up headway for movement  $x$  (s),
- $t_{f,\text{base}}$  = base follow-up headway from Exhibit 82 (s),
- $t_{f,HV}$  = heavy vehicle adjustment factor = 0.9 for major streets with one lane in each direction and 1.0 for major streets with two or three lanes in each direction, and
- $P_{HV}$  = proportion of heavy vehicles for movement (decimal).

**Step 5: Calculate Potential Capacities**

The potential capacity  $c_{p,x}$  for movement  $x$  is calculated using Equation 118.

$$c_{p,x} = v_{c,x} \frac{e^{-v_{c,x} t_{c,x}/3,600}}{1 - e^{-v_{c,x} t_{f,x}/3,600}} \quad \text{Equation 118}$$

where

- $c_{p,x}$  = potential capacity for movement  $x$  (veh/h),
- $v_{c,x}$  = conflicting flow rate for movement  $x$  (veh/h),
- $t_{c,x}$  = critical headway for movement  $x$  (s), and
- $t_{f,x}$  = follow-up headway for movement  $x$  (s).

**Step 6: Calculate Movement Capacities**

The movement capacities  $c_{m,j}$  for the Rank 2 movements  $j$  (major street left turns, movements 1 and 4, and minor street right turns, movements 9 and 12) are calculated using Equation 119.

$$c_{m,j} = c_{p,j} \quad \text{Equation 119}$$

**Exhibit 82. Base follow-up headways.**

Vehicle Movement	Number of Lanes on Major Street		
	2	4	6
Major street left turn (1, 4)	2.2	2.2	3.1
Minor street right turn (9, 12)	3.3	3.3	3.9
Minor street through movement (8, 11)	4.0	4.0	4.0
Minor street left turn (7, 10)	3.5	3.5	3.8

where

$c_{m,j}$  = movement capacity for Rank 2 movements  $j$  ( $j = 1, 4, 9,$  or  $12$ ), and

$c_{p,j}$  = potential capacity for Rank 2 movements  $j$ .

The movement capacities  $c_{m,k}$  for the Rank 3 movements  $k$  (minor street through movements 8 and 11) are calculated using Equation 120 and Equation 121.

$$c_{m,8} = c_{p,8} \left( 1 - \frac{v_1}{c_{m,1}} \right) \left( 1 - \frac{v_4}{c_{m,4}} \right) \quad \text{Equation 120}$$

$$c_{m,11} = c_{p,11} \left( 1 - \frac{v_1}{c_{m,1}} \right) \left( 1 - \frac{v_4}{c_{m,4}} \right) \quad \text{Equation 121}$$

where

$c_{m,1}, c_{m,4}, c_{m,8}, c_{m,11}$  = movement capacity for movements 1, 4, 8, and 11, respectively (veh/h),

$c_{p,8}, c_{p,11}$  = potential capacity for movements 8 and 11, respectively (veh/h), and

$v_1, v_4$  = demand flow rates for movements 1 and 4, respectively (veh/h).

The movement capacities  $c_{m,l}$  for the Rank 4 movements 7 and 10 (minor street left turns) are calculated using Equation 122 through Equation 126.

$$c_{m,7} = (c_{p,7})(p')(p_{0,12}) \quad \text{Equation 122}$$

$$c_{m,10} = (c_{p,10})(p')(p_{0,9}) \quad \text{Equation 123}$$

$$p_{0,i} = 1 - \frac{v_i}{c_{m,i}} \quad \text{Equation 124}$$

$$p' = 0.65 p'' - \frac{p''}{p'' + 3} + 0.6 \sqrt{p''} \quad \text{Equation 125}$$

$$p'' = \begin{cases} p_{0,1} p_{0,4} p_{0,11} & \text{(movement 7)} \\ p_{0,1} p_{0,4} p_{0,8} & \text{(movement 10)} \end{cases} \quad \text{Equation 126}$$

where

$c_{m,i}$  = movement capacity for movement  $i$  (veh/h),

$c_{p,7}, c_{p,10}$  = potential capacity for movements 7 and 10, respectively (veh/h),

$p_{0,i}$  = probability of a queue-free state for movement  $i$  (decimal),

$v_i$  = demand flow rate for movement  $i$  (veh/h), and

$p', p''$  = adjustments to the impedance created by higher-ranked movements (decimal).

### Step 7: Calculate Shared Lane Capacities

The shared lane capacities  $c_{SH}$  (veh/h) of the two minor street approaches are calculated as follows:

$$c_{SH} = \frac{\sum_y v_y}{\sum_y \frac{v_y}{c_{m,y}}} \quad \text{Equation 127}$$

where

- $c_{SH}$  = shared lane capacity of a minor street approach (veh/h),
- $v_y$  = demand flow rate of movement  $y$  in the subject shared lane (veh/h), and
- $c_{m,y}$  = movement capacity of movement  $y$  in the subject shared lane (veh/h).

### Step 8: Calculate Delay Estimation

The average control delay  $d$  for a movement is calculated using Equation 128.

$$d = \frac{3,600}{c_{m,x}} + 900T \left[ \frac{v_x}{c_{m,x}} - 1 + \sqrt{\left( \frac{v_x}{c_{m,x}} - 1 \right)^2 + \frac{\left( \frac{3,600}{c_{m,x}} \right) \left( \frac{v_x}{c_{m,x}} \right)}{450T}} \right] + 5 \quad \text{Equation 128}$$

where

- $d$  = average control delay (s/veh),
- $v_x$  = demand flow rate for movement  $x$  (veh/h),
- $c_{m,x}$  = movement capacity of movement  $x$  (veh/h), and
- $T$  = analysis time period (h), default = 0.25.

The average control delay for all vehicles on an approach  $d_A$  is calculated using Equation 129.

$$d_A = \frac{d_r v_r + d_t v_t + d_l v_l}{v_r + v_t + v_l} \quad \text{Equation 129}$$

where

- $d_A$  = average control delay for the approach (s/veh),
- $d_r, d_t, d_l$  = control delay for the right-turn, through, and left-turn movements on the approach, respectively (s/veh), and
- $v_r, v_t, v_l$  = demand flow rate of the right-turn, through, and left-turn movements on the approach, respectively (veh/h).

The average intersection control delay  $d_I$  is calculated using Equation 130.

$$d_I = \frac{d_{A,1} v_{A,1} + d_{A,2} v_{A,2} + d_{A,3} v_{A,3} + d_{A,4} v_{A,4}}{v_{A,1} + v_{A,2} + v_{A,3} + v_{A,4}} \quad \text{Equation 130}$$

where

- $d_I$  = average control delay for the intersection (s/veh),
- $d_{A,x}$  = average control delay for approach  $x$  (s/veh), and
- $v_{A,x}$  = demand flow rate for approach  $x$  (s/veh).

## 6. Level of Service Analysis (AWSC and TWSC)

The LOS ranges for STOP-controlled intersections are given in Exhibit 83 on the basis of control delay. Note that if the volume-to-capacity ratio exceeds 1.00, the LOS will be F regardless of the control delay.

**Exhibit 83. Level of service: STOP-controlled intersections.**

Control Delay (s/veh)	Volume-to-Capacity Ratio, $X$	
	$X \leq 1.0$	$X > 1.0$
$\leq 10$	A	F
$> 10-15$	B	F
$> 15-25$	C	F
$> 25-35$	D	F
$> 35-50$	E	F
$> 50$	F	F

Source: Adapted from HCM (2016), Exhibit 20-2.

## 7. Queuing Analysis (AWSC and TWSC)

The deterministic average queue for each STOP-controlled approach at an intersection is determined by dividing the approaches' average delay by its capacity:

$$Q_A = 3,600 \frac{d_A}{c_{SH}} \tag{Equation 131}$$

where

- $Q_A$  = deterministic average queue on approach (veh),
- $d_A$  = average approach delay (s/veh), and
- $c_{SH}$  = shared lane capacity of a minor street approach (veh/h).

The deterministic average queue does not take into account the bunching of vehicle arrivals within the analysis period. An approximate estimate of the stochastic 95th percentile queue can be obtained by multiplying the deterministic average queue by 2.0 (the approximate ratio of the 95th percentile to the mean for a Poisson process).

For approaches with multiple lanes, the queue per lane can be estimated by dividing by the number of lanes and applying an uneven lane usage adjustment factor to the result.

$$QPL = \frac{Q \times LU}{N} \tag{Equation 132}$$

where

- $QPL$  = queue per lane (veh/ln),
- $Q$  = queue (veh),
- $LU$  = adjustment factor for uneven lane utilization (unitless), default = 1.10, and
- $N$  = number of lanes on the approach (ln).

## 8. Worksheets

The worksheets shown in Exhibit 84 through Exhibit 86 illustrate how the computations might be laid out in a spreadsheet and can be used to organize manual calculations, as desired.

**Exhibit 84. AWSC intersection delay computation worksheet.**

All-Way STOP Control (AWSC) Intersection Planning Method Worksheet												
Approach	NB			SB			EB			WB		
Turning movement	LT	TH	RT	LT	TH	RT	LT	TH	RT	LT	TH	RT
Volume												
Lanes												
Delay												
Delay												

Notes: NB = northbound, SB = southbound, EB = eastbound, WB = westbound, LT = left turn, TH = through, RT = right turn.

**Exhibit 85. TWSC input data worksheet.**

Two-Way STOP Control (TWSC) Intersection Planning Method, Input Data Worksheet													
Movement	1	2	3	4	5	6	7	8	9	10	11	12	
Demand volume, $V_i$													
Lanes													
Peak hour factor $PHF$													
Flow rate, $v_i$													
Proportion of heavy vehicles, $P_{HV}$													

**Exhibit 86. TWSC capacity and delay computation worksheet.**

Two-Way STOP Control (TWSC) Intersection Planning Method, Capacity and Delay Worksheet									
Movements	1	3	7	8	9	10	11	12	
Flow rate, $v_i$									
Conflicting flows, $v_c$									
Critical headway, $t_c$									
Follow-up headway, $t_f$									
Potential capacity, $c_{p,x}$									
Movement capacity, $c_{m,l}$									
Control delay, $d$									
Approach control delay, $d_A$									
Intersection control delay, $d_i$									

**Exhibit 87. Example sensitivity analysis table for intersection reliability.**

Capacity (veh/h)	Percentile Demand (veh/h)		
	25th	Median (50th)	75th
25th percentile			
50th percentile (median)			
75th percentile			

Note: Table is intentionally blank. Entries would be average delays in seconds per vehicle.

## 9. Reliability Analysis

The HCM does not provide a method for estimating the variability of delay at an intersection. The analyst might perform a sensitivity analysis by repeating the planning computations using the 25th percentile and 75th percentile demands of the year and the 25th percentile and 75th percentile capacities of the year (taking into account incidents) and report the results in a table such as shown in Exhibit 87.

## 10. Multimodal LOS

The HCM does not provide bicycle, pedestrian, transit, or truck LOS measures for STOP-controlled intersections.

## 11. Example

Preparation of an example problem was deferred to a future edition of the Guide.

## 12. Reference

*Highway Capacity Manual: A Guide to Multimodal Mobility Analysis*. 6th ed. Transportation Research Board, Washington, D.C., 2016.



## N. Roundabouts

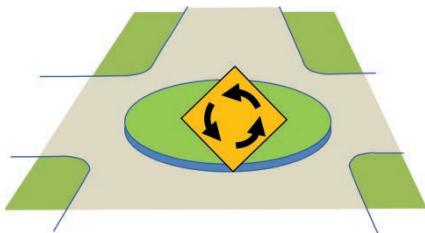

### 1. Overview

A roundabout is a circular intersection in which vehicles within the circulatory roadway have the right-of-way. Movements entering the roundabout must yield to traffic already circulating. The planning method for roundabouts is based on the operational analysis method described in HCM Chapter 22.

### 2. Applications

The procedures in this chapter are designed to support the following planning and preliminary engineering analyses:

- Feasibility studies of intersection improvements, and
- Land development traffic impact studies.

### 3. Analysis Methods Overview

Intersection performance can be directly measured in the field or it can be estimated in great detail using microsimulation. However, the resource requirements of both of these methods render them generally impractical for most planning and preliminary engineering applications. HCM Chapter 22 provides a much less resource-intensive approach to estimating intersection performance; however, it is generally impractical for many planning and preliminary engineering analyses to use the HCM methods with 100 percent field-measured inputs. Employing the HCM methods with the defaults identified in HCM Chapter 22 reduces the data requirements but still requires specialized software to implement the complex computations.

As indicated by the unshaded boxes in Exhibit 88, this chapter presents a simplified HCM medium-level method for evaluating roundabouts.

### 4. Simplified HCM Method

The roundabout planning analysis approach predicts the capacity and delay for each roundabout approach, as well as the delay for the intersection. The planning method is a simplification of the HCM operational analysis method.



**Exhibit 88. Analysis options for roundabouts.**

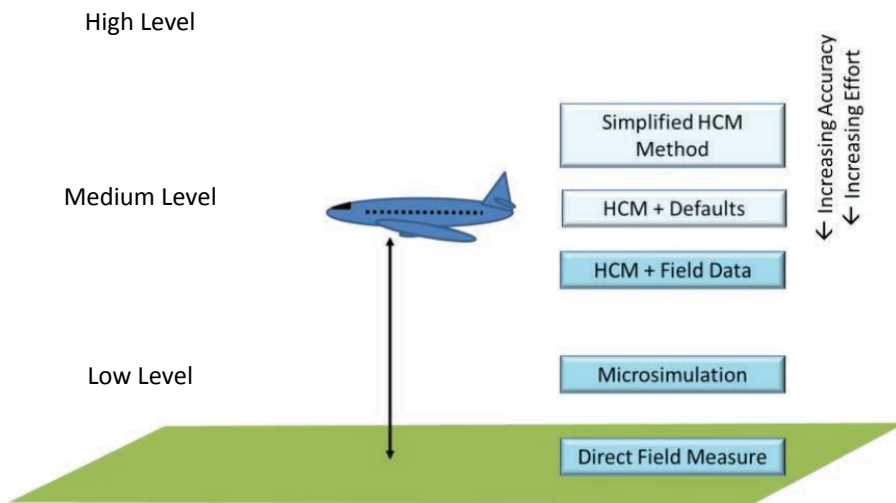

### Data Needs, Assumptions, and Limitations

The following assumptions and limitations apply to the simplified HCM planning method for roundabouts:

- No pedestrians,
- No bypass lanes, and
- No more than two lanes within the roundabout and on any entry.

The planning method for roundabouts requires four inputs:

- The volume for each movement,
- The number of lanes on each approach,
- The peak hour factor (default = 0.92), and
- The proportion of heavy vehicles for each movement (default = 3%).

### Volume-to-Capacity Ratio Estimation

The roundabout planning method includes eight steps to ultimately estimate delay, as shown in Exhibit 89 and described herein. The first seven steps are used to obtain the volume-to-capacity ratios.

#### Step 1: Estimate Flow Rates from Demands

Movement demand volumes are converted to flow rates using Equation 133.

$$v_i = \frac{V_i}{PHF} \tag{Equation 133}$$

where

- $v_i$  = demand flow rate for movement  $i$  (veh/h),
- $V_i$  = demand volume for movement  $i$  (veh/h), and
- $PHF$  = peak hour factor (decimal), default = 0.92.

If only approach volumes are known, one of the methods described in Section D8 can be used to generate turning-movement volumes.

**Exhibit 89. Planning method for roundabouts.**

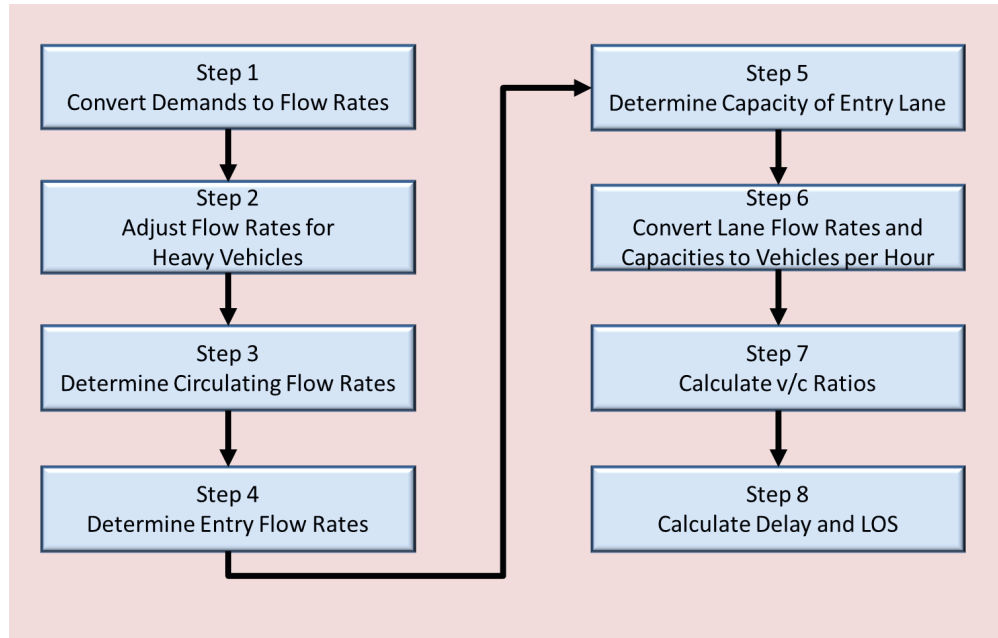

**Step 2: Heavy Vehicle Adjustment**

Demand flow rates in vehicles per hour are adjusted for the presence of heavy vehicles using Equation 134 and Equation 135, producing adjusted flow rates in passenger cars per hour (pc/h).

$$v_{i,pce} = \frac{v_i}{f_{HV}} \tag{Equation 134}$$

$$f_{HV} = \frac{1}{1 + P_T} \tag{Equation 135}$$

where

- $v_{i,pce}$  = adjusted flow rate for movement  $i$  (pc/h),
- $v_i$  = demand flow rate for movement  $i$  (veh/h),
- $f_{HV}$  = heavy vehicle adjustment factor (decimal), and
- $P_T$  = proportion of heavy vehicles for movement  $i$  (decimal).

**Step 3: Determine Circulating Flow Rates**

The circulating flow rates  $v_{c,xx,pce}$  are calculated for each approach direction  $xx$  of the roundabout using Equation 136 through Equation 139.

$$v_{c,NB,pce} = v_{WBU,pce} + v_{SBL,pce} + v_{SBU,pce} + v_{EBT,pce} + v_{EBL,pce} + v_{EBU,pce} \tag{Equation 136}$$

$$v_{c,SB,pce} = v_{EBU,pce} + v_{NBL,pce} + v_{NBU,pce} + v_{WBT,pce} + v_{WBL,pce} + v_{WBU,pce} \tag{Equation 137}$$

$$v_{c,EB,pce} = v_{NBU,pce} + v_{WBL,pce} + v_{WBU,pce} + v_{SBT,pce} + v_{SBL,pce} + v_{SBU,pce} \tag{Equation 138}$$

$$v_{c,WB,pce} = v_{SBU,pce} + v_{EBL,pce} + v_{EBU,pce} + v_{NBT,pce} + v_{NBL,pce} + v_{NBU,pce} \tag{Equation 139}$$

where

- $v_{c,xx,pce}$  = circulating flow rate opposing approach direction  $xx$  (pc/h), where  $xx$  = NB (northbound), SB (southbound), EB (eastbound), or WB (westbound), and
- $v_{xy,pce}$  = adjusted flow rate for turning-movement  $y$  from approach direction  $xx$  (pc/h), where  $y$  = U (U-turn), L (left turn), or T (through movement).

**Step 4: Determine Entry Flow Rates by Lane**

For single-lane entries, the entry flow rate is the sum of all movement flow rates using that entry. For two-lane entries, the following procedure may be used to assign flows to each lane:

1. If only one lane is available for a given movement, the flow for that movement is assigned only to that lane.
2. The remaining flows are assumed to be distributed across the two lanes, subject to the constraints imposed by any designated or de facto lane assignments and any observed or estimated lane utilization imbalances.

Five generalized multilane cases may be analyzed with this procedure. For cases in which a movement may use more than one lane, a check should first be made to determine what the assumed lane configuration may be. This may differ from the designated lane assignment based on the specific turning-movement patterns being analyzed. These assumed lane assignments are given in Exhibit 90. For intersections with a different number of legs on each approach, the analyst should exercise reasonable judgment in assigning volumes to each lane.

On the basis of the assumed lane assignment for the entry and the lane utilization effect described above, flow rates can be assigned to each lane by using the formulas given in Exhibit 91.

**Step 5: Determine Capacity of Entry Lane**

The entry lane capacity  $c_{e,pce}$  is determined on the basis of the number of entry and conflicting lanes, using the appropriate equation given in Exhibit 92.

**Step 6: Convert Lane Flow Rates and Capacities to Vehicles per Hour**

The flow rates and capacities by lane, in passenger cars per hour, are converted back into vehicles per hour using Equation 140 and Equation 141.

$$v_j = v_{j,pce} f_{HV} \tag{Equation 140}$$

**Exhibit 90. Assumed (de facto) lane assignments.**

Designated Lane Assignment	Assumed Lane Assignment
<b>LT, TR</b>	If $v_U + v_L > v_T + v_{R,e}$ : L, TR (de facto left-turn lane)
	If $v_{R,e} > v_U + v_L + v_T$ : LT, R (de facto right-turn lane)
	Else LT, TR
<b>L, LTR</b>	If $v_T + v_{R,e} > v_U + v_L$ : L, TR (de facto through-right lane)
	Else L, LTR
<b>LTR, R</b>	If $v_U + v_L + v_T > v_{R,e}$ : LT, R (de facto left-through lane)
	Else LTR, R

Notes:  $v_U, v_L, v_T, v_{R,e}$  are, respectively, the U-turn, left-turn, through, and nonbypass right-turn flow rates (pc/h) using a given entry.

L = left, LT = left-through, TR = through-right, LTR = left-through-right, and R = right.

**Exhibit 91. Flow rate assignments for two-lane entries.**

Assumed Lane Assignment	Flow Rate Assignment (pc/h)	
	Left Lane	Right Lane
L, TR	$v_U + v_L$	$v_T + v_{R,e}$
LT, R	$v_U + v_L + v_T$	$v_{R,e}$
LT, TR	$(\%LL)v_e$	$(\%RL)v_e$
L, LTR	$(\%LL)v_e$	$(\%RL)v_e$
LTR, R	$(\%LL)v_e$	$(\%RL)v_e$

Notes:  $v_U, v_L, v_T, v_{R,e}$  are, respectively, the U-turn, left-turn, through, and nonbypass right-turn flow rates (pc/h) using a given entry, and  $v_e$  is the total entry flow (pc/h).

L = left, LT = left-through, TR = through-right, LTR = left-through-right, and R = right.

$\%RL$  = percentage of entry traffic using the right lane and  $\%LL$  = percentage of entry traffic using the left lane, with  $\%RL + \%LL = 1$ .

$$c_j = c_{j,pce} f_{HV} \tag{Equation 141}$$

where

- $v_j$  = demand flow rate for lane  $j$  (veh/h),
- $v_{j,pce}$  = adjusted flow rate for lane  $j$  (pc/h),
- $f_{HV}$  = heavy vehicle adjustment factor (decimal) from Equation 135,
- $c_j$  = capacity of lane  $j$  (veh/h), and
- $c_{j,pce}$  = capacity of lane  $j$  (pc/h).

**Step 7: Calculate Volume-to-Capacity Ratios**

The volume-to-capacity ratio  $x_j$  for each lane  $j$  is calculated using Equation 142.

$$x_j = \frac{v_j}{c_j} \tag{Equation 142}$$

where

- $v_j$  = demand flow rate of the subject lane  $j$  (veh/h), and
- $c_j$  = capacity of the subject lane  $j$  (veh/h).

**Step 8: Calculate Delay Estimation**

If average control delay is desired to be computed, the volume-to-capacity ratio results from Step 7 are carried forward into Step 8.

**Exhibit 92. Capacity equations for roundabouts.**

Entry Lanes	Conflicting Lanes	Capacity Equation
1	1	$c_{e,pce} = 1,130e^{-0.003v_{c,pce}}$
2	1	Both lanes: $c_{e,pce} = 1,130e^{-0.003v_{c,pce}}$
1	2	$c_{e,pce} = 1,130e^{-0.007v_{c,pce}}$
2	2	Right lane: $c_{e,pce} = 1,130e^{-0.007v_{c,pce}}$ Left lane: $c_{e,pce} = 1,130e^{-0.0075v_{c,pce}}$

Note:  $c_{e,pce}$  = entry lane capacity (pc/h) and  $v_{c,pce}$  = conflicting flow rate for the entry (pc/h).

**Step 8a: Calculate Average Control Delay per Entry Lane.** The average control delay  $d$  for each entry lane is calculated using Equation 143.

$$d = \frac{3,600}{c} + 900T \left[ x - 1 + \sqrt{(x-1)^2 + \frac{\left(\frac{3,600}{c_{m,x}}\right)x}{450T}} \right] + 5(\min[x, 1]) \quad \text{Equation 143}$$

where

- $d$  = average control delay of the subject lane (s/veh),
- $c$  = capacity of the subject lane (veh/h),
- $T$  = analysis period duration (h) (default = 0.25 h),
- $x$  = volume-to-capacity ratio of the subject lane, and
- $c_{m,x}$  = movement capacity of movement  $x$  in the subject lane.

**Step 8b: Calculate Average Control Delay per Approach.** For a single-lane entry, the average control delay for the approach  $d_{\text{approach}}$  is the same as the average control delay for the approach's entry lane. For two-lane entries, the average control delay for the approach is calculated using Equation 144.

$$d_{\text{approach}} = \frac{d_{LL}v_{LL} + d_{RL}v_{RL}}{v_{LL} + v_{RL}} \quad \text{Equation 144}$$

where

- $d_{\text{approach}}$  = average control delay for the approach (s/veh),
- $d_{LL}$  = average control delay for the left lane (s/veh),
- $v_{LL}$  = demand flow rate in the left lane (veh/h),
- $d_{RL}$  = average control delay for the right lane (s/veh), and
- $v_{RL}$  = demand flow rate in the right lane (veh/h).

**Step 8c: Calculate Intersection Average Control Delay.** The average control delay for the intersection  $d_{\text{intersection}}$  is calculated using Equation 145.

$$d_{\text{intersection}} = \frac{\sum d_i v_i}{\sum v_i} \quad \text{Equation 145}$$

where

- $d_{\text{intersection}}$  = average control delay for the intersection (s/veh),
- $d_i$  = average control delay for approach  $i$  (s/veh), and
- $v_i$  = demand flow rate for approach  $i$  (veh/h).

## Level of Service Analysis

The LOS ranges for motor vehicles are given in Exhibit 93, in the basis of control delay. Note that if the volume-to-capacity ratio exceeds one, the LOS will be F regardless of the control delay.

## Queuing Analysis

The deterministic average queue  $Q$  for each approach at an intersection is determined by dividing the average delay for that approach by the capacity for that approach.

**Exhibit 93. Level of service, roundabouts.**

Control Delay (s/veh)	Volume-to-Capacity Ratio, $X$	
	$X \leq 1.0$	$X > 1.0$
$\leq 10$	A	F
$>10-15$	B	F
$>15-25$	C	F
$>25-35$	D	F
$>35-50$	E	F
$>50$	F	F

Source: Adapted from HCM (2016), Exhibit 22-8.

$$Q_A = 3,600 \frac{d}{c} \quad \text{Equation 146}$$

where

$Q_A$  = deterministic average queue on approach (veh),  
 $d$  = average control delay on approach (s/veh), and  
 $c$  = capacity of approach (veh/h).

The deterministic average queue does not take into account the bunching of vehicle arrivals within the analysis period. An approximate estimate of the stochastic 95th percentile queue can be obtained by multiplying the deterministic average queue by 2.0 (the approximate ratio of the 95th percentile to the mean for a Poisson process).

For approaches with multiple lanes, the queue per lane can be estimated by dividing by the number of lanes and applying an uneven lane usage adjustment factor to the result.

$$QPL = \frac{Q \times LU}{N} \quad \text{Equation 147}$$

where

$QPL$  = queue per lane (veh/ln),  
 $Q$  = queue (veh),  
 $LU$  = adjustment factor for uneven lane utilization (unitless), default = 1.10, and  
 $N$  = number of lanes on the approach (ln).

## 5. Worksheets

The worksheets provided in Exhibit 94 and Exhibit 95 illustrate how the computations might be laid out in a spreadsheet and can be used to organize manual calculations, as desired.

## 6. Reliability Analysis

The HCM does not provide a method for estimating the variability of delay at an intersection. The analyst might perform a sensitivity analysis by repeating the planning computations using the 25th percentile and 75th percentile demands during the year and the 25th percentile and 75th percentile capacities during the year (taking into account incidents) and report the results in a table such as shown in Exhibit 96.

**Exhibit 94. Roundabout input worksheet.**

Roundabouts Planning Method, Input Worksheet												
Approach	NB			SB			EB			WB		
Turning-movement	LT	TH	RT	LT	TH	RT	LT	TH	RT	LT	TH	RT
Demand volume, $V_i$												
Lanes												
Peak hour factor												
Demand flow rate, $v_i$												

Notes: NB = northbound, SB = southbound, EB = eastbound, WB = westbound, LT = left turn, TH = through, RT = right turn.

**Exhibit 95. Roundabout volume-to-capacity ratio and delay computation worksheet.**

Roundabouts Planning Method, Volume Adjustments												
Approach	NB			SB			EB			WB		
Turning-movement	LT	TH	RT	LT	TH	RT	LT	TH	RT	LT	TH	RT
Demand flow rate, $v_i$												
Heavy vehicle adjustment factor, $f_{HV}$												
Adjusted flow rate, $v_{i,pce}$												
Circulating flow rates, $v_{xx,pce}$												
	NB Lane 1	NB Lane 2		SB Lane 1	SB Lane 2		EB Lane 1	EB Lane 2		WB Lane 1	WB Lane 2	
Entry flow rates by lane, $v_j$												
Capacity of entry lane, $c_j$												
Volume-to-capacity ratio, $x_j$												
Lane control delay, $d$												
Approach control delay, $d_{approach}$												
Interstion control delay, $d_{intersection}$												

Notes: NB = northbound, SB = southbound, EB = eastbound, WB = westbound, LT = left turn, TH = through, RT = right turn.

**Exhibit 96. Example sensitivity analysis table for intersection reliability.**

Capacity (veh/h)	Percentile Demand (veh/h)		
	25th	Median (50th)	75th
25th percentile			
50th percentile (median)			
75th percentile			

Note: Table is intentionally blank. Entries would be average delays in seconds per vehicle.

## **7. Multimodal LOS**

The HCM does not provide bicycle, pedestrian, transit, or truck LOS measures for roundabouts.

## **8. Example**

Preparation of an example problem was deferred to a future edition of the Guide.

## **9. Reference**

*Highway Capacity Manual: A Guide to Multimodal Mobility Analysis*. 6th ed. Transportation Research Board, Washington, D.C., 2016.





# O. Pedestrians, Bicyclists, and Public Transit

## 1. Overview

In addition to providing performance measures and computational methods for the motorized vehicle mode, the HCM also provides a variety of measures for pedestrians and bicycles on various types of on- and off-street facilities. The HCM also provides a transit LOS measure for evaluating on-street public transit service in a multimodal context. A sister publication, the *Transit Capacity and Quality of Service Manual* (TCQSM) (Kittelson & Associates et al. 2013), provides a variety of performance measures, computational methods, and spreadsheet tools to evaluate the capacity, speed, reliability, and quality of service of on- and off-street transit service.



The HCM's pedestrian and bicycle performance measures focus on (1) the impacts of other facility users on pedestrians and bicyclists and (2) facility design and operation features under the control of a transportation agency. However, some analyses may also be interested in the effects of urban design on pedestrians' and bicyclists' potential comfort and enjoyment while using a facility. In those cases, additional measures, such as the Walkability Index (Hall 2010) or the Bicycle Environment Quality Index (San Francisco Department of Public Health 2009), could be appropriate.

This section is organized by HCM system element, providing guidance on applying the HCM and TCQSM's pedestrian, bicycle, and transit methods to a planning and preliminary engineering study. As research has not yet been conducted to quantify the pedestrian and bicycle experience for all types of HCM system elements, not every mode is addressed in every subsection below.

## 2. Freeways

### Pedestrians and Bicycles

In most cases, pedestrians and bicycles are prohibited on freeways; therefore, the operations and quality of service of these modes on freeways is not assessed. In some cases, a multiple-use path is provided within the freeway facility, with a barrier separating non-motorized and motorized traffic. In these situations, the pedestrian and bicycle facility should be analyzed as an off-street pathway (see Section O8). In situations where bicycles are allowed on freeway shoulders, the HCM provides no guidance on evaluating performance. It is not recommended to use the HCM's multi-lane highway method for bicycles to evaluate bicycle quality of service on freeway shoulders, as the method was developed from urban street and suburban multilane highway data and has not been calibrated to freeway environments.

## Transit

Buses operating on freeways in level terrain will generally operate at the same speed as other vehicular traffic, although buses designed to primarily operate on urban streets may not have the power to travel at higher freeway speeds (e.g., over 55 mph). In addition, buses designed to primarily operate on urban streets may have poor performance on steep grades—particularly when fully loaded with passengers—and are recommended to be evaluated as a truck in these cases. Buses designed for freeway travel (i.e., motor coaches designed for long-distance trips) generally do not experience these issues.

When bus routes stop along a freeway facility (e.g., at a stop or station in the freeway median or within a freeway interchange), the TCQSM can be consulted for guidance on estimating the delay associated with each stop. The TCQSM can also be consulted for performance measures for rail transit operating within a freeway right-of-way.

In general, buses operating on freeway facilities will experience the same conditions as other vehicles in the general purpose or managed lanes (where applicable) and could be assigned the same LOS as for motorized vehicle traffic generally. Alternatively, where buses stop along the freeway facility to serve passengers, the transit LOS measure for urban streets described in Section O4 could be applied to the stops along the freeway facility, with appropriate adjustments to the assumed average passenger trip length and baseline travel time rate, and considering the pedestrian LOS of the access route to the stop.

## 3. Multilane and Two-Lane Highways

### Pedestrians

When pedestrian facilities exist along a multilane highway (e.g., a sidewalk along a multilane highway in a suburban area), the facility can be analyzed as an urban street pedestrian facility (see Section O4). However, if the pedestrian facility is separated from a multilane or two-lane highway by a barrier, or is generally located more than 35 feet away from the travel lanes, it should be analyzed as an off-street facility (see Section O8). Lower-speed two-lane highways (posted speeds of 45 mph or less) can be evaluated using the urban street pedestrian method (Section O4), whether or not a sidewalk exists. However, the HCM's urban street pedestrian method is not calibrated for, and not recommended for use with, higher speed two-lane highways or multilane highways lacking sidewalks or sidepaths.

### Bicycles

HCM Chapter 15 provides a method for evaluating bicyclist perceptions of quality of service along multilane and two-lane highways. The method generates a bicycle LOS score, which can be translated into a bicycle LOS letter or used on its own. Exhibit 97 lists the required data for this method and provides suggested default values.

Of the inputs listed in Exhibit 97, the LOS result is highly sensitive to shoulder width and heavy vehicle percentage and is somewhat sensitive to lane width and pavement condition (particularly very poor pavement).

The calculation of the bicycle LOS score is readily performed by hand, following the steps given in HCM Chapter 15, or can be easily set up in a spreadsheet.

## Transit

The guidance presented above for transit operating on freeways (Section O2) is also applicable to multilane and two-lane highways.

**Exhibit 97. Required data for multilane and two-lane highway bicycle analysis.**

Input Data (units)	Default Value
Speed limit (mph)	Must be provided
Directional automobile demand (veh/h)*	Must be provided
Number of directional lanes	1 (two-lane highway), 2 (multilane highway)
Lane width (ft)*	12
Shoulder width (ft)*	6
Pavement condition rating (FHWA 5-point scale)	3.5 (good)
Percentage heavy vehicles (decimal)*	0.06**
Peak hour factor (decimal)*	0.88
Percent of segment with occupied on-highway parking	0.00

Notes: See HCM Chapter 15 for definitions of the required input data.

\*Also used by the multilane or two-lane highway LOS methods for motorized vehicles.

\*\*HCM Chapter 26 provides state-specific default values.

## 4. Urban Streets

### Pedestrians

The HCM provides three pedestrian performance measures for urban street segments and facilities: space (reflecting the density of pedestrians on a sidewalk); speed (reflecting intersection delays); and a pedestrian LOS score (reflecting pedestrian comfort with the walking environment).

Exhibit 98 lists the data required for these measures and provides suggested default values.

Calculating the pedestrian LOS score requires a number of inputs. Most of these can be defaulted, and the ones that cannot be defaulted are used by the urban street motorized vehicle LOS method. Given that different pedestrian design standards are typically used for different combinations of roadway functional classifications and area types, it is recommended that analysts develop sets of default values covering the most common combinations for their study area, based on typical local conditions or design standards.

Pedestrian space and speed are sensitive to *effective sidewalk width*, representing the portion of the sidewalk that is actually used by pedestrians. Common effective width reductions are 1.5 feet adjacent to the curb and 2.0 feet adjacent to a building face; Exhibits 24-8 and 24-9 in HCM Chapter 24, Off-Street Pedestrian and Bicycle Facilities, provide effective width reductions for many other types of objects (e.g., street trees, street light poles, bus stop shelters, café tables). The effective width used for analysis purposes should be based on the narrowest point of the sidewalk from an effective width standpoint. As the types of objects that create effective width reductions will vary depending on the sidewalk design (e.g., use of landscape buffers, street tree presence) and the adjacent land uses, it is recommended that analysts develop a set of local effective width default values that cover the most common situations.

The HCM provides a pedestrian LOS score (and associated LOS letter) for urban street *links* (between signalized intersections), *segments* (a link plus the downstream intersection), and *facilities* (multiple contiguous segments) that relates to pedestrian perceptions of quality of service for each element. The pedestrian LOS score uses the same scale as related bicycle and transit LOS scores for urban streets, and a related urban street automobile traveler perception score, which allows for multimodal analyses in which the relative quality of service of each travel mode can be evaluated and compared. At present, at a facility level, the HCM methodology only evaluates signalized urban streets, and not streets with all-way stops, roundabouts, or interchanges. However, the link methodology can be used to evaluate pedestrian facilities along any urban street section between intersections.

**Exhibit 98. Required data for urban street pedestrian analysis.**

Input Data (units)	For SPC	For SPD	For PLOS	Default Value
Sidewalk width (ft)	•	•	•	12 (CBD), 5 (other)
Effective sidewalk width (ft)	•	•		8.5 (CBD), 3.5 (other)
Bi-directional pedestrian volume (ped/h)	•	•		Must be provided
Free-flow pedestrian speed (ft/s)	•	•	•	4.4
Segment length (ft)*		•	•	Must be provided
Signalized intersection delay walking along street (s)*		•	•	See Section O5 or use 12 (CBD), 30 (suburban)
Signalized intersection delay crossing street (s)*			•	See Section O5 or use 12 (CBD), 50 (suburban)
Outside lane width (ft)*			•	12
Bicycle lane width (ft)			•	0
Shoulder/parking lane width (ft)			•	1.5 (curb and gutter only) 8 (parking lane provided)
Percentage of segment with occupied on-street parking (decimal)			•	0.00 (no parking lane) 0.50 (parking lane provided)
Street trees or other barriers (yes/no)**			•	No
Landscape buffer width (ft)			•	0 (CBD), 6 (other)
Curb presence (yes/no)			•	Yes
Median type (divided/undivided)			•	Undivided
Number of travel lanes*			•	Must be provided
Directional vehicle volume (veh/h)*			•	Must be provided
Vehicle running speed (mph)*			•	See Section K6 or use the posted speed
Intersection pedestrian LOS score (unitless)			•	Calculated, see Section O5
Average distance to nearest signal (ft)			•	One-third the segment length

Notes: See HCM Chapter 18 for definitions of the required input data.

SPC = space, SPD = speed, PLOS = pedestrian level of service, CBD = central business district.

\*Input data used by or calculation output from the HCM urban street motorized vehicle LOS method.

\*\*Street trees, bollards, or other similar vertical barriers 3 feet or more tall, or a continuous barrier at least 3 feet tall.

As noted above, the pedestrian LOS methodology requires a number of input values, but most of these can be defaulted, particularly when local default values have been established for different combinations of roadway functional class and area type. The calculations can be performed by hand or (preferably when large numbers of segments will be evaluated) incorporated into a spreadsheet.

Equations in HCM Chapter 18, Urban Street Segments, are used to calculate a link LOS score. This score can be converted to a LOS letter and reported by itself, if the purpose of the analysis is to evaluate the pedestrian environment between intersections. Otherwise, the analyst can proceed to calculate a segment LOS score.

The segment LOS score combines the link LOS score and the signalized intersection LOS score (see Section O5), weighting the two scores by the relative amounts of time that pedestrians experience each element. It is calculated using HCM Equation 18-39. A roadway crossing difficulty factor also enters into this equation. This factor incorporates the lesser of the delays pedestrians experience when (1) trying to cross the street at an unsignalized midblock location (if legal), or (2) walking to the nearest traffic signal, crossing the street, and walking back on the other side of the street. The segment LOS score can be converted to a LOS letter and reported by itself (using HCM Exhibit 18-2), if the purpose of the analysis is to evaluate the pedestrian environment

along a street segment, including intersection and street crossing effects. Otherwise, the analyst can proceed to calculate a facility LOS score.

The facility LOS score is calculated similarly to the segment LOS score, weighting the LOS scores of the individual links and signalized intersections that form the facility by the relative amounts of time that pedestrians experience each element. It is calculated using Equation 16-7 in HCM Chapter 16, Urban Street Facilities.

**Planning Procedure for Estimating Pedestrian LOS**

When pedestrian crowding and delays at signals are not a concern, then this procedure (adapted from the HCM segment method) can be used to quickly evaluate the pedestrian LOS for stretches of urban streets between signalized intersections. Signalized intersection effects, pedestrian density, and midblock roadway crossing difficulty are not considered in this procedure. For high pedestrian volume locations (over 1,000 pedestrians per hour), the HCM procedure for evaluating pedestrian space should be used.

The pedestrian segment LOS is determined by the perceived separation between pedestrians and vehicle traffic:

- Higher traffic speeds and higher traffic volumes reduce the perceived separation,
- Physical barriers and parked cars between motorized vehicle traffic and the pedestrians increase the perceived separation, and
- Sidewalks wider than 10 feet do not further increase the perceived separation.

The segment pedestrian LOS is calculated as follows:

$$\begin{aligned}
 PLOS = & -1.2276 \times \ln([f_{LV} \times W_T] + [0.5 \times W_1] + [0.5 \times \%OSP] + [f_B \times W_B] + [f_{SW} \times W_S]) \\
 & + \frac{0.0091V}{4N} + (0.0004 \times SPD^2) + 6.0468
 \end{aligned}$$

Equation 148

where

- $PLOS$  = pedestrian level of service score for a segment (unitless),
- $\ln$  = natural logarithm,
- $f_{LV}$  = low volume factor (unitless) = 1.00 if  $V > 160$  veh/h and  $(2.00 - 0.005V)$  otherwise,
- $W_T$  = distance from the inner edge of the outside lane to the curb (ft) (see Exhibit 99),
- $W_1$  = distance from the outer edge of the outside lane to the curb (ft) (see Exhibit 99),

**Exhibit 99. Measurement of widths for pedestrian LOS analysis.**

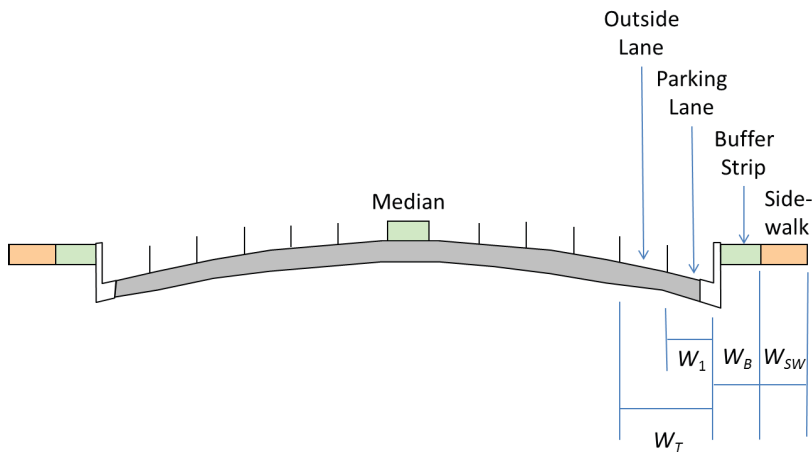

- $\%OSP$  = percent of segment with occupied on-street parking (percent),
- $f_B$  = buffer area coefficient (unitless) = 5.37 if a barrier is provided and 1.00 otherwise,
- $W_B$  = buffer width (ft), the distance between the curb and sidewalk (see Exhibit 99),
- $f_{sw}$  = sidewalk presence coefficient (unitless) =  $6 - 0.3W_s$ ,
- $W_s$  = sidewalk width (ft) (see Exhibit 99), with a maximum allowed value of 10 ft,
- $V$  = directional volume of vehicles in the direction closest to pedestrians (veh/h),
- $N$  = number of through lanes of traffic in the direction closest to pedestrians, and
- $SPD$  = average vehicle speed between intersections (excluding stops) (mph).

Vertical objects at least 3 feet tall, such as street trees, bollards, or concrete barriers, that are sufficiently dense to be perceived as a barrier are treated as barriers for the purposes of determining the buffer area coefficient  $f_b$ .

The furnishings zone portion of a sidewalk (e.g., the area with street furniture, planters, and tree wells), such as often found in central business districts with wide sidewalks, is treated as part of the buffer strip width  $W_B$ . In these cases, the portion of the sidewalk allocated to pedestrian circulation would be used to determine the sidewalk width  $W_{sw}$ .

The pedestrian LOS method has not been designed or tested for application to rural highways and other roads where a sidewalk is not present and the traffic volumes are low but the speeds are high.

The PLOS score value is converted into a LOS letter using Exhibit 100.

### Special Cases

This section gives guidance on the analysis of special cases.

**Treatment of Sections with Significant Grades.** The pedestrian LOS equations are designed for essentially flat grades (grades of under 2% of any length). For steeper grades, the analyst should consider applying an adjustment to the LOS estimation procedure to account for the negative impact of both upgrades and downgrades on pedestrian quality of service. This adjustment probably should be sensitive both to the steepness of the grade and its length. However, research available at the time this Guide was produced did not provide a basis for computing such an adjustment. The precise adjustment is left to the discretion of the analyst.

**Pedestrian LOS and ADA Compliance.** The Americans with Disabilities Act (ADA) sets various accessibility requirements for public facilities, including sidewalks on public streets. The United States Access Board ([www.access-board.gov](http://www.access-board.gov)) has developed specific accessibility guidelines that apply to sidewalks and pedestrian paths.

Because pedestrian LOS is defined to reflect the average perceptions of the public, it is not designed to specifically reflect the perspectives of any particular subgroup of the public. Thus, the analyst

**Exhibit 100. Level of service, pedestrians on urban streets.**

PLOS Score	LOS
≤1.50	A
>1.50–2.50	B
>2.50–3.50	C
>3.50–4.50	D
>4.50–5.50	E
>5.50	F

Source: Adapted from HCM (2016), Exhibit 18-2.

should use caution if applying the pedestrian LOS methodology to facilities that are not ADA compliant. Pedestrian LOS is not designed to reflect ADA compliance or non-compliance, and therefore should not be considered a substitute for an ADA compliance assessment of a pedestrian facility.

**Treatment of Street Sections with a Parallel Multiuse Path.** Pedestrian LOS for urban streets applies to sidewalks and sidepaths located within 35 feet of the street (i.e., the distance within which research has demonstrated that vehicular traffic influences pedestrians' perceptions of quality of service). When a pedestrian pathway is located parallel to the street, but more than 35 feet from the street, it should be evaluated as an off-street pathway (see Section 08).

**Treatment of Streets with Sidewalk on Only One Side.** The pedestrian LOS analysis for both sides of the street proceeds normally. On one side, the sidewalk is evaluated. On the other side, the pedestrian LOS is evaluated using a sidewalk width of 0 feet.

**Treatment of Discontinuous Sidewalks.** Segments with relatively long gaps (over 100 feet) in the sidewalk should be split into sub-segments and the LOS for each evaluated separately.

The pedestrian LOS methodology is not designed to take into account the impact of short gaps in sidewalk (under 100 feet). Until such a methodology becomes available, short gaps may be neglected in the pedestrian LOS calculation. However, the analyst should report the fact that there are gaps in the sidewalk in addition to reporting the LOS grade.

**Treatment of One-Way Traffic Streets.** The pedestrian LOS analysis proceeds normally for both sides of the street, even when it is one-way. Note, however, that the lane and shoulder width for the left-hand lane are used for the sidewalk on the left-hand side of the street.

**Treatment of Streets with Pedestrian Prohibitions or Sidewalk Closures.** If pedestrians are prohibited from walking along the street by local ordinance or a permanent sidewalk closure, then the pedestrian LOS is F. No pedestrian LOS computations are performed.

**Treatment of Streets with Frontage Roads.** In some cases a jurisdiction will provide frontage roads to an urban street. There will usually be no sidewalks along the urban street, but there will be sidewalks along the outside edge of each frontage road.

If the analyst has information indicating that pedestrians walk along the urban street without the sidewalks, then the pedestrian LOS analysis should be performed for the urban street. If the analyst has information indicating that pedestrians walk exclusively along the frontage roads, then the pedestrian LOS analysis should be performed for the frontage roads.

**Treatment of Pedestrian Overcrossings.** The pedestrian LOS methodology is not designed to account for pedestrian bridges, either across the urban street or along the urban street.

**Treatment of Railroad Crossings.** The pedestrian LOS methodology is not designed to account for the impacts on pedestrian LOS of railroad crossings with frequent train traffic.

**Treatment of Unpaved Paths/Sidewalks.** The pedestrian LOS methodology is not designed to account for unpaved paths in the urban street right-of-way. The analyst should use local knowledge about the climate and the seasonal walkability of unpaved surfaces to determine whether an unpaved surface can be considered as almost as good as a paved sidewalk for the purpose of the pedestrian LOS computation. Otherwise the unpaved path should be considered the same as no sidewalk for the purpose of pedestrian LOS computation.

**Treatment of Major Driveways.** The HCM pedestrian LOS method and the planning procedure presented here are not designed to address the impacts of high-volume driveways on the pedestrian experience.

## Bicycles

The HCM provides two bicycle performance measures for urban street segments and facilities: average travel speed (reflecting intersection delays) and a bicycle LOS score (reflecting bicyclist comfort with the bicycling environment). Exhibit 101 lists the data required for these measures and provides suggested default values.

As can be seen in Exhibit 101, calculating the bicycle LOS score requires a number of inputs. Most of these can be defaulted, and the ones that cannot be defaulted are used by the urban street motorized vehicle or pedestrian LOS methods. Given that different bicycle design standards are typically used for different combinations of roadway functional classifications and area types, it is recommended that analysts develop sets of default values covering the most common combinations for their study area, based on typical local conditions or design standards.

### Bicycle LOS Score

The HCM provides a bicycle LOS score (and associated LOS letter) for urban street *links* (between signalized intersections), *segments* (a link plus the downstream intersection), and *facilities* (multiple contiguous segments) that relates to bicyclist perceptions of quality of service for each element. The bicycle LOS score uses the same scale as related pedestrian and transit LOS scores, and a related urban street automobile traveler perception score, which allows for multimodal analyses in which the relative quality of service of each travel mode can be evaluated and compared. At present, at a facility level, the HCM methodology only evaluates signalized urban streets and not streets with all-way stops, roundabouts, or interchanges. However, the link methodology can be used to evaluate bicycle facilities along any urban street section between intersections.

**Exhibit 101. Required data for urban street bicycle analysis.**

Input Data (units)	For SPD	For BLOS	Default Value
Bicycle running speed (mph)	•		12
Signalized intersection delay (s)	•	•	See Section O5 or use 10 (CBD), 22 (suburban)
Segment length (ft)*	•	•	Must be provided
Bicycle lane width (ft)**		•	5 (if provided)
Outside lane width (ft)**		•	12
Shoulder/parking lane width (ft)**		•	0 (curb and gutter only) 8 (parking lane provided)
Percentage of segment with occupied on-street parking (percent)**		•	0 (no parking lane) 50 (parking lane provided)
Pavement condition rating (1–5)		•	3.5 (good)
Curb presence (yes/no)**		•	Yes
Median type (divided/undivided)**		•	Undivided
Number of travel lanes*		•	Must be provided
Directional vehicle volume (veh/h)*		•	Must be provided
Vehicle running speed (mph)*		•	See Section K6 or use the posted speed
Percentage heavy vehicles (%)*		•	3%
Access points on the right side (points/mi)		•	17 (urban arterial), 10.5 (suburban arterial), 30.5 (urban collector), 24 (suburban collector)
Intersection bicycle LOS score (unitless)		•	Calculated, see Section O5

Notes: See HCM Chapter 18 for definitions of the required input data.

SPD = speed, BLOS = bicycle level of service, CBD = central business district.

\*Input data used by or calculation output from the HCM urban street motorized vehicle LOS method.

\*\*Input data used by the HCM urban street pedestrian LOS method.



As noted, the bicycle LOS methodology requires a number of input values, but most of these can be defaulted, particularly when local default values have been established for different combinations of roadway functional class and area type. The calculations can be performed by hand or (preferably when large numbers of segments will be evaluated) incorporated into a spreadsheet.

Equations 18-41 through 18-44 in HCM Chapter 18, Urban Street Segments, are used to calculate a link LOS score. This score can be converted to a LOS letter and reported by itself, if the purpose of the analysis is to evaluate the bicycling environment between intersections. Otherwise, the analyst can proceed to calculate a segment LOS score.

The segment LOS score combines the link LOS score and the signalized intersection LOS score (see Section O5), weighting the two scores by the relative amounts of time that bicyclists experience each element. It is calculated using HCM Equation 18-46. The number of access points per mile on the right side of the road (e.g., driveways, unsignalized cross-streets) also enters into this equation as a factor that causes discomfort to bicyclists. The segment LOS score can be converted to a LOS letter and reported by itself (using HCM Exhibit 18-3), if the purpose of the analysis is to evaluate the bicycling environment along a street segment, including intersection and access point effects. Otherwise, the analyst can proceed to calculate a facility LOS score.

The facility LOS score is calculated similarly to the segment LOS score, weighting the LOS scores of the individual links and signalized intersections that form the facility by the relative amounts of time that bicyclists experience each element. It is calculated using Equation 16-10 in HCM Chapter 16, Urban Street Facilities.

### Planning Procedure for Evaluating Bicycle LOS

If bicyclist perceptions of signalized intersections are not a significant concern, the following planning method (adapting the HCM segment LOS method) can be used to quickly assess bicycle LOS for a street. The segment bicycle LOS is calculated according to the following equation:

$$\begin{aligned}
 BLOS = & 0.507 \times \ln\left(\frac{V}{4N}\right) + (0.199 \times f_s \times [1 + 0.1038HV]^2) \\
 & + \left(7.066 \times \left[\frac{1}{PC}\right]^2\right) - (0.005 \times W_e^2) + 0.760
 \end{aligned}
 \tag{Equation 149}$$

where

- $BLOS$  = bicycle level of service score for a segment (unitless),
- $\ln$  = natural logarithm,
- $V$  = directional volume of vehicles in the direction closest to bicyclists (veh/h),
- $N$  = number of through lanes of traffic in the direction closest to bicyclists,
- $f_s$  = effective speed factor (unitless) =  $(1.1199 \times \ln[S - 20] + 0.8103)$ ,
- $HV$  = proportion of heavy vehicles in the motorized vehicle volume (%),
- $PC$  = pavement condition rating, using FHWA's five-point scale (1 = poor, 5 = excellent),
- $W_e$  = average effective width of the outside through lane (ft) =  $W_v - (0.1 \times \%OSP)$  if  $W_l < 4$  and  $W_v + W_l - (0.2 \times \%OSP)$  otherwise, with a minimum value of 0,
- $W_v$  = effective width of the outside through lane as a function of traffic volume (ft) =  $W_T$  if  $V > 160$  veh/h or the street is divided, and  $W_T \times (2 - 0.005V)$  otherwise,
- $\%OSP$  = percent of segment with occupied on-street parking (percent),
- $W_l$  = width of the bicycle lane and paved shoulder (ft); a parking lane can only be counted as shoulder if 0% occupied (see Exhibit 102) and the gutter width is not included, and

**Exhibit 102. Widths used in bicycle LOS analysis.**

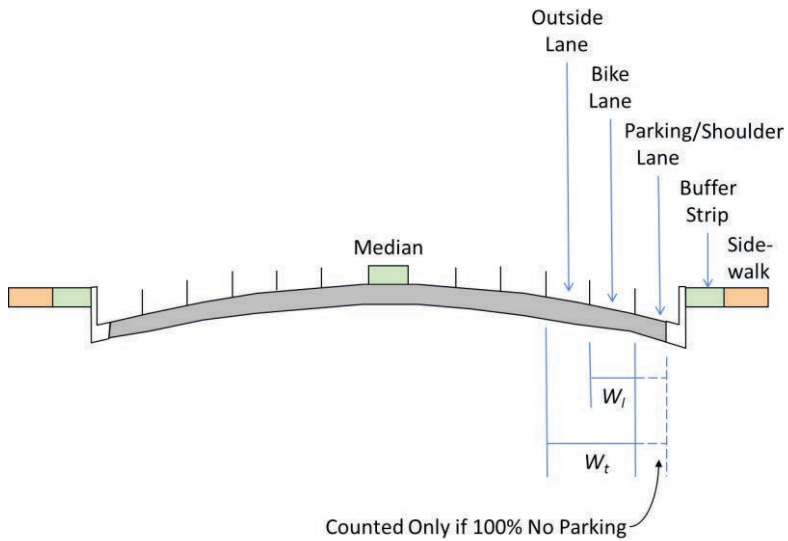

$W_T$  = width of the outside through lane, bicycle lane if present, and paved shoulder if present (ft); a parking lane can only be counted as shoulder if 0% occupied (see Exhibit 102) and the gutter width is not included.

If the traffic volume  $V$  is less than 200 veh/h, the value of  $HV$  must be less than or equal to 50% to avoid unrealistically poor LOS results for the combination of low volume and high percentage of heavy vehicles.

Note that this method does not account for bicycle-to-bicycle interference and should not be used where bicycle flows are expected to be high enough that significant bicycle-to-bicycle interference occurs.

The bicycle LOS score is converted into a letter using Exhibit 103.

**Simplifications from the HCM**

The HCM method for estimating bicycle level of service for urban streets is documented in HCM Chapters 16 (Urban Street Facilities), 18 (Urban Street Segments), and 19 (Signalized Intersections). This Guide makes the following simplifications to the HCM method to improve its utility for planning applications:

- Intersection analysis and facility analysis are excluded,
- Estimation of bicycle speeds and delays is excluded,

**Exhibit 103. Level of service, bicycles on urban streets.**

BLOS Score	LOS
≤1.50	A
>1.50–2.50	B
>2.50–3.50	C
>3.50–4.50	D
>4.50–5.50	E
>5.50	F

Source: Adapted from HCM (2016), Exhibit 18-3.

- Bicycle link LOS is used to characterize the segment (intersection plus link), and
- No provision is made for characterizing overall facility bicycle LOS.

For these features, the analyst must apply the HCM method as described in the HCM, applying default values as needed.

### *Special Cases*

This section explains the evaluation of bicycle LOS for special cases.

**Treatment of Sections with Significant Grades.** The bicycle LOS equations are designed for essentially flat grades (grades of under 2% of any length). For steeper grades, the analyst should consider applying an adjustment to the LOS estimation procedure to account for the negative impact of both upgrades and downgrades on bicycle LOS. This adjustment probably should be sensitive both to the steepness of the grade and its length. However, research available at the time of production of this Guide did not provide a basis for computing such an adjustment. It is left to the discretion of the analyst.

**Treatment of Sections with Parallel Multiuse Path.** The bicycle LOS is computed separately for bicycles using the street and for bicycles using the parallel path. The bicycle LOS for the path is computed using the off-street path procedures described in Section O8.

**Treatment of Bus Lanes, Bus Streets, and High Bus Volumes.** The bicycle LOS methodology is not designed to adequately represent bicyclist perceptions of quality of service when they are operating on streets with frequent bus service with bus stops requiring bicyclists to move left to pass stopped buses. The analyst may choose to impose a weighting factor on the bus volume to better reflect the greater impact of the stopping buses on bicyclist LOS. The weighting factor would be at the analyst's discretion.

**Treatment of Railroad Crossings and In-Street Tracks.** The LOS methodology is not designed to account for the impacts of railroad crossings and the presence of tracks in the street (which may constitute a crash risk for bicyclists traveling parallel to the tracks) on bicycle LOS. The analyst may choose to adjust the pavement condition factor to a lower value to reflect the impacts of parallel in-pavement tracks and railroad crossings on bicycle LOS.

## **Transit**

The HCM provides a transit LOS score for urban streets that reflects passenger comfort as they walk to a bus stop, wait for a bus, and ride on the bus. In addition, the TCQSM (Kittelson & Associates et al. 2013) provides the most up-to-date methods for calculating bus capacities and estimating average bus speeds on urban streets. Exhibit 104 lists the data required for these measures and suggests default values.

The HCM's transit LOS measure can be used to evaluate fixed-route transit service (e.g., bus, streetcar) that operates on the street and makes periodic stops to serve passengers. The TCQSM (Kittelson & Associates et al. 2013) can be used to evaluate the quality of service provided by other transit modes that travel within, above, or below the street right-of-way.

### *Bus Capacity*

Bus capacity on an urban street is usually controlled by the capacity of the bus stops to accept and discharge buses. Bus capacity reflects the number of buses per hour that can serve the critical bus stop along a facility, at a desired level of reliability. The critical bus stop is typically the bus stop with the highest dwell time (i.e., serves the greatest number of passengers),

**Exhibit 104. Required data for urban street transit analysis.**

Input Data (units)	For CAP	For SPD	For TLOS	Default Value
Dwell time at critical stop (s)	•	•	○	60 (CBD, major transfer point), 30 (urban), 15 (suburban)
Average dwell time along facility (s)		•	○	45 (CBD), 20 (urban), 15 (suburban)
Coefficient of variation of dwell times (decimal)	•	•	○	0.60
Through traffic <i>g/C</i> ratio at critical stop (decimal)*	•	•	○	0.45 (CBD), 0.35 (other)
Curb lane <i>v/c</i> ratio at critical stop's intersection* (decimal)	•	•	○	Must be provided
Busiest stop location (online/offline)	•	•	○	Offline
Clearance time at critical stop (s)	•	•	○	10 (online stop, queue jump), 14 (far-side/midblock offline stop), 25 (near-side offline stop)
Number of loading areas at critical stop	•	•	○	1
Design failure rate (%)	•	•	○	10% (CBD), 2.5% (other), 25% (when calculating speed)
Bus frequency (bus/h)		•	•	Must be provided
Average bus stop spacing (stops/mi)		•	○	8 (CBD), 6 (urban), 4 (suburban)
Posted speed limit (mph)*		•	○	Must be provided
Average bus acceleration rate (ft/s <sup>2</sup> )		•	○	3.4
Average bus deceleration rate (ft/s <sup>2</sup> )		•	○	4.0
Bus lane type (4 categories)		•	○	Mixed traffic
Traffic signal progression (3 categories)		•	○	Typical
Average passenger load factor (p/seat)			•	Must be provided
Average excess wait time (min)			•	3
Percentage of stops with shelter (%)			•	25%
Percentage of stops with bench (%)			•	25%
Average passenger trip length (mi)			•	3.7
Pedestrian LOS score (decimal)**			•	Must be provided

Notes: See the TCQSM for definitions of the required input data.

CAP = capacity, SPD = speed, TLOS = transit level of service, CBD = central business district.

○ = required input if bus speeds are not already known (e.g., when evaluating future conditions).

\*Input data used by or calculation output from the HCM urban street automobile LOS method.

\*\*Calculation output from the HCM pedestrian LOS method.

but a lower-passenger-volume stop with short green times for buses or that experiences high right-turning traffic volumes can also be the critical stop. Bus capacity is calculated using Equation 150 and Equation 151, adapted from the TCQSM:

$$B = N_{el} f_{ib} \frac{3,600(g/C)}{t_c + t_d(g/C) + Zc_v t_d} \tag{Equation 150}$$

$$f_{ib} = 1 - f_i \left( \frac{v_{cl}}{c_{cl}} \right) \tag{Equation 151}$$

where

*B* = bus capacity (bus/h),

*N<sub>el</sub>* = number of effective loading areas at a bus stop, from Exhibit 105,

*f<sub>ib</sub>* = traffic blockage adjustment factor (decimal),

3,600 = number of seconds in 1 hour,

**Exhibit 105. Efficiency of multiple loading areas at bus stops.**

Number of Physical Loading Areas	Bus Stop Type	
	Online	Offline
1	1.00	1.00
2	1.75	1.85
3	2.45	2.60
4	2.65	3.25
5	2.75	3.75

Source: Adapted from TCQSM (Kittelson & Associates et al., 2013), Exhibit 6-63.

Note: Values are numbers of effective loading areas for a given number of physical loading areas.

$g/C$  = ratio of effective green time to total traffic signal cycle length (decimal),

$t_c$  = clearance time (s),

$t_d$  = average (mean) dwell time (s),

$Z$  = standard normal variable corresponding to a desired failure rate, from Exhibit 106,

$c_v$  = coefficient of variation of dwell times (decimal),

$f_l$  = bus stop location factor (decimal), from Exhibit 107,

$v_{cd}$  = curb lane traffic volume at intersection (veh/h), and

$c_{cd}$  = curb lane capacity at intersection (veh/h).

When more than one bus can use the critical bus stop at a time (i.e., more than one *loading area* is provided), the bus stop’s capacity will be greater than if only one loading area was provided. Exhibit 105 gives the number of effective loading areas for a given number of physical loading areas, for both online stops (buses stop in the travel lane) and offline stops (buses stop out of the travel lane).

Exhibit 106 provides values for  $Z$ , the standard normal variable, for different design *failure rates*—the percentage of time that a bus should arrive at a bus stop only to have to wait for other buses to finish serving their passengers before space opens up for the arriving bus to enter the stop. Capacity is maximized when a queue of buses exists to move into a bus stop as soon as other buses leave, but this situation causes significant bus delays and schedule reliability problems. Therefore, a lower design rate is normally used as an input for determining a design capacity, balancing capacity with operational reliability. However, the TCQSM’s method for estimating

**Exhibit 106. Values of  $Z$  associated with given failure rates.**

Design Failure Rate	$Z$
1.0%	2.330
2.5%	1.960
5.0%	1.645
7.5%	1.440
10.0%	1.280
15.0%	1.040
20.0%	0.840
25.0%	0.675

Source: Adapted from TCQSM (Kittelson & Associates et al., 2013), Exhibit 6-56.

**Exhibit 107. Bus stop location factor  $f_l$  values.**

Bus Stop Location	Bus Freedom to Maneuver		
	Buses Restricted to Right Lane	Buses Can Use Adjacent Lane	Right Turns Prohibited or Dual Bus Lanes
Near-side of intersection	1.0	0.9	0.0
Middle of the block	0.9	0.7	0.0
Far-side of intersection	0.8	0.5	0.0

Source: Adapted from TCQSM (Kittelson & Associates et al., 2013), Exhibit 6-66.

bus speed is calibrated to maximum capacity and therefore uses a 25% (maximum practical) failure rate in its calculation.

The location of the critical bus stop relative to the nearest intersection and the ability of buses to avoid right-turning traffic also influence capacity. Exhibit 107 gives values for the bus stop location factor  $f_l$  used in Equation 151.

The curb lane capacity can be estimated using the procedure given in Section L4 or estimated from Exhibit 108, for a given combination of  $g/C$  ratio (effective green time divided by the traffic signal cycle length) and conflicting pedestrian volume for right turns.

### Bus Speed

Two options are provided for planning-level estimates of bus speeds along urban streets:

1. If only a planning estimate of bus speeds is desired, then Option 1 can be followed. This option requires less data and is faster to calculate. It accounts for traffic and traffic signal delays in a generalized way.
2. If it is desired to estimate both automobile and bus speeds, then Option 2 can be followed. This option applies the same basic method used for automobiles, but makes adjustments to reflect (a) overlapping signal delay time and bus dwell time to serve passengers, (b) bus delays waiting to re-enter the traffic stream, and (c) bus congestion at bus stops when more than half of the facility’s bus capacity is being used.

**Option 1: Generalized Bus Speed Method.** This option is based on the TCQSM’s bus speed estimation method. In this option, bus speeds are calculated in four steps. First, an unimpeded

**Exhibit 108. Approximate curb lane capacities.**

Conflicting Pedestrian Volume (ped/h)	$g/C$ Ratio for Curb Lane					
	0.35	0.40	0.45	0.50	0.55	0.60
0	510	580	650	730	800	870
100	440	510	580	650	730	800
200	360	440	510	580	650	730
400	220	290	360	440	510	580
600	70	150	220	290	360	440
800	*	*	70	150	220	290
1,000	*	*	*	*	70	150

Source: HCM (2016), based on  $1,450 \times (g/C) \times [1 - (\text{pedestrian volume} \times (g/C) / 2,000)]$  with PHF = 1.

Note: \*Vehicles can only turn at the end of green, assume one or two per traffic signal cycle. Values shown are for CBD locations, multiply by 1.1 for other locations.

bus travel time rate, in minutes per mile, is calculated for the condition in which a bus moves along a street without traffic or traffic signal delays, with the only source of delay being stops to serve passengers. Second, additional delays due to traffic and traffic signals are estimated. Third, the bus travel time rate is converted to an equivalent speed. Finally, the speed is reduced to reflect the effects of bus congestion.

**Step 1: Unimpeded Bus Travel Time Rate.** The unimpeded bus travel time rate is based on the posted speed, the number of stops per mile, the average dwell time per stop, and typical bus acceleration and deceleration rates. It is based on the delay experienced with each bus stop (deceleration, dwell time, and acceleration) and the time spent traveling at the bus's running speed (typically the posted speed) between stops. It is calculated using Equation 152 through Equation 157:

$$t_u = \frac{t_{rs} + N_s(t_{dt} + t_{acc} + t_{dec})}{60} \quad \text{Equation 152}$$

$$t_{rs} = \frac{L_{rs}}{1.47v_{run}} \quad \text{Equation 153}$$

$$L_{rs} = 5,280 - N_s L_{ad} \geq 0 \quad \text{Equation 154}$$

$$L_{ad} = 0.5at_{acc}^2 + 0.5dt_{dec}^2 \quad \text{Equation 155}$$

$$t_{acc} = \frac{1.47v_{run}}{a} \quad \text{Equation 156}$$

$$t_{dec} = \frac{1.47v_{run}}{d} \quad \text{Equation 157}$$

where

$t_u$  = unimpeded running time rate (min/mi),

$t_{rs}$  = time spent at running speed (s/mi),

$N_s$  = average stop spacing (stops/mi),

$t_{dt}$  = average dwell time of all stops within the section (s/stop),

$t_{acc}$  = acceleration time per stop (s/stop),

$t_{dec}$  = deceleration time per stop (s/stop),

60 = number of seconds per minute,

$L_{rs}$  = distance traveled at running speed per mile (ft/mile),

1.47 = conversion factor (5,280 ft/mi/3,600 s/h),

$v_{run}$  = bus running speed on the facility (typically the posted speed) (mph),

$L_{ad}$  = distance traveled at less than running speed per stop (ft/stop),

$a$  = average bus acceleration rate to running speed (ft/s<sup>2</sup>), and

$d$  = average bus deceleration rate from running speed (ft/s<sup>2</sup>).

If the calculated length traveled at running speed in Equation 155 is less than zero, the bus cannot accelerate to the input running speed before it must begin decelerating to the next stop. In this case, the calculation sequence must be performed again with a lower running speed selected. The maximum speed that can be reached before the bus has to begin decelerating again can be computed using Equation 158 and Equation 159; however, the analyst may wish to choose a lower speed to reflect that bus drivers will typically cruise at a constant speed for some distance between stops, rather than decelerating immediately after accelerating.

$$t_{acc,dc} = \sqrt{\frac{5,280/N_s}{0.5a + \frac{a^2}{d}}} \tag{Equation 158}$$

$$v_{max} = \frac{a \times t_{acc,dc}}{1.47} \tag{Equation 159}$$

where

- $t_{acc,dc}$  = distance-constrained acceleration time (s),
- $N_s$  = average stop spacing (stops/mi),
- $a$  = bus acceleration rate (ft/s<sup>2</sup>),
- $d$  = bus deceleration rate (ft/s<sup>2</sup>), and
- $v_{max}$  = maximum speed achievable between stops (mph).

**Step 2: Additional Bus Travel Time Delays.** Next, additional bus travel time delays  $t_l$  (in minutes per mile) are estimated directly from Exhibit 109, using the bus facility type, traffic signal progression quality, and area type as inputs.

**Step 3: Base Bus Speed.** The unimpeded bus travel time rate from Step 1 and the additional bus travel time delays from Step 2 are added together to obtain a base bus travel time rate  $t_r$ , which is then converted into a base bus speed  $S_b$ :

$$t_r = t_u + t_l \tag{Equation 160}$$

$$S_b = \frac{60}{t_r} \tag{Equation 161}$$

where

- $t_r$  = base bus running time rate (min/mi),
- $t_u$  = unimpeded running time rate (min/mi),
- $t_l$  = additional running time losses (min/mi),
- 60 = number of minutes in an hour, and
- $S_b$  = base bus speed (mph).

**Step 4: Average Bus Speed.** When at least half of a facility’s maximum bus capacity is scheduled, bus congestion at bus stops reduces bus speeds below the base speed calculated in Step 3. The amount of this speed reduction is given by the bus–bus interference factor  $f_{bb}$ , which can be

**Exhibit 109. Estimated bus running time losses on urban streets  $t_l$  (min/mi).**

Condition	Bus Lane	Bus Lane, No Right Turns	Bus Lane With Right-Turn Delays	Bus Lanes Blocked by Traffic	Mixed Traffic Flow
<b>CENTRAL BUSINESS DISTRICT</b>					
<b>Typical</b>		1.2	2.0	2.5–3.0	3.0
<b>Signals set for buses</b>		0.6	1.4		
<b>Signals more frequent than bus stops</b>		1.75	2.75	3.25	3.75
<b>ARTERIAL ROADWAYS OUTSIDE THE CBD</b>					
<b>Typical</b>	0.7				1.0

Source: Adapted from TCQSM (Kittelson & Associates et al., 2013), Exhibit 6-73.



**Exhibit 110. Bus–bus interference factor values.**

Bus Volume–to– Maximum Capacity Ratio	Bus–Bus Interference Factor
<0.5	1.00
0.5	0.97
0.6	0.94
0.7	0.89
0.8	0.81
0.9	0.69
1.0	0.52
1.1	0.35

Source: TCQSM (Kittelson & Associates et al., 2013), Exhibit 6-75.

estimated from Exhibit 110. The input to this exhibit is the bus volume–to–maximum capacity ratio, where maximum bus capacity is estimated by using a 25% failure rate in Exhibit 106 when determining the value of the standard normal variable  $Z$  used in the bus capacity equation (Equation 150). Under typical conditions and if bus stops can only serve one bus at a time (i.e., one loading area per stop), at least 10–15 buses per hour need to be scheduled before bus speeds are affected.

Equation 162 is used to estimate the average bus speed on the urban street facility.

$$S_{bus} = S_b f_{bb} \tag{Equation 162}$$

where

- $S_{bus}$  = average bus speed along facility (mph),
- $S_b$  = base bus speed (mph), and
- $f_{bb}$  = bus–bus interference factor (decimal).

**Option 2: Modified Auto Speed Method.** This option modifies the auto speed estimation method for urban street segments with signalized intersections (see Section K6) to reflect additional delays experienced by buses and to account for potentially overlapping traffic signal delay and dwell time delay.

The auto equation for estimating segment travel time is modified as follows for buses:

$$T_{i,bus} = \frac{5,280 FFS}{3,600 L_i} + d + d_{mb} + d_{bs} \tag{Equation 163}$$

where

- $T_{i,bus}$  = base bus travel time for segment  $i$  (s),
- $FFS$  = midblock free-flow speed (mph),
- 5,280 = number of feet per mile,
- 3,600 = number of seconds per hour,
- $L_i$  = distance from upstream intersection stop bar to downstream intersection stop bar for segment  $i$  (ft),
- $d$  = average control delay (s),
- $d_{mb}$  = midblock bottleneck delay (if any) (s), and
- $d_{bs}$  = total bus stop delay in the segment (s).

Total bus stop delay in the segment is calculated as follows:

$$d_{bs} = N_s (t_{dt} + t_{acc} + t_{dec} + t_{re}) \quad \text{Equation 164}$$

where

$$\begin{aligned} d_{bs} &= \text{total bus stop delay in the segment (s),} \\ N_s &= \text{number of bus stops in the segment (stops),} \\ t_{dt} &= \text{average dwell time per stop (s/stop),} \\ t_{acc} &= \text{bus acceleration time per stop (s/stop),} \\ t_{dec} &= \text{bus deceleration time per stop (s/stop),} \\ t_{re} &= \text{average re-entry delay per stop (s/stop) = } t_{cl} - 10, \text{ and} \\ t_{cl} &= \text{average clearance time per stop (s/stop).} \end{aligned}$$

When applying Equation 164, the number of bus stops in the segment includes all mid-block stops and any bus stop associated with the downstream intersection (even if far-side and technically located in the next segment). Similarly, any bus stop associated with the upstream intersection is excluded from the count of bus stops.

Average bus speed in the segment is calculated as follows:

$$S_{i,bus} = \frac{3,600 L_i}{5,280 T_{i,bus}} f_{bb} \quad \text{Equation 165}$$

where

$$\begin{aligned} S_{i,bus} &= \text{average bus speed for segment } i \text{ including all delays (mph),} \\ L_i &= \text{distance from upstream intersection stop bar to downstream intersection stop bar for} \\ &\quad \text{segment } i \text{ (ft),} \\ T_{i,bus} &= \text{base bus travel time for segment } i \text{ (s), and} \\ f_{bb} &= \text{bus–bus interference factor (decimal) from Exhibit 110.} \end{aligned}$$

Average facility bus speed is calculated as follows:

$$S_{bus} = \frac{3,600 \sum L_i}{5,280 \sum T_{i,bus}} \quad \text{Equation 166}$$

where

$$\begin{aligned} S_{bus} &= \text{average bus speed along facility (mph),} \\ L_i &= \text{distance from upstream intersection stop bar to downstream intersection stop bar for} \\ &\quad \text{segment } i \text{ (ft),} \\ 5,280 &= \text{number of feet per mile,} \\ 3,600 &= \text{number of seconds per hour,} \\ T_{i,bus} &= \text{base bus travel time for segment } i \text{ (s).} \end{aligned}$$

### Transit LOS Score

The HCM provides a transit LOS score (and associated LOS letter) for urban street *segments* (a link plus the downstream intersection) and *facilities* (multiple contiguous segments). The segment score relates to transit passengers' experiences walking to or from bus stops in the segment, waiting for buses at bus stops in the segment, and riding on buses within the segment. The transit LOS score uses the same scale as related pedestrian and bicycle LOS scores, and a related auto traveler perception score, allowing for multimodal analyses in which the relative quality of service of each travel mode can be evaluated and compared to each other. The calculations

can be performed by hand or (preferably when large numbers of segments will be evaluated) incorporated into a spreadsheet.

HCM Equations 18-56 through 18-63 are used to calculate a link LOS score. This score can be converted to a LOS letter and reported by itself (using HCM Exhibit 18-3), if the purpose of the analysis is to evaluate transit conditions within a segment. Otherwise, a facility score is calculated by weighting the LOS scores of the individual segments that form the facility by the relative length of each segment. It is calculated using HCM Equation 16-13.

The transit LOS score is particularly sensitive to the bus frequency provided as an input, and is somewhat sensitive to the average bus speed and passenger load factor provided as inputs.

The HCM transit LOS score computations can be applied without change using defaults as needed. Alternatively, the transit LOS score computation steps shown below provide a few simplifications on the HCM procedure for planning applications.

$$TLOS = 6.0 - (1.50 \times s_{w-r}) + (0.15 \times PLOS) \tag{Equation 167}$$

where

- $TLOS$  = transit LOS score (unitless),
- $s_{w-r}$  = transit wait and ride score (unitless), and
- $PLOS$  = pedestrian LOS score (unitless).

The computed transit LOS score is converted to an LOS letter using the equivalencies given in Exhibit 111.

**Pedestrian LOS Estimation.** The pedestrian LOS score for the urban street is estimated using the pedestrian LOS model described earlier in this section. Better PLOS values (i.e., LOS A-C) improve the TLOS score relative to what it would be if only transit factors were considered, while worse PLOS values (i.e., LOS D-F) reduce the TLOS score.

**Transit Wait-Ride Score Estimation.** The transit wait-ride score is a function of a bus headway factor  $f_h$  that reflects the multiplicative change in ridership along a route at a given headway, relative to the ridership at 60-minute headways, and a perceived travel time factor  $f_{ptt}$  that reflects the multiplicative change in ridership along a route at a given perceived travel time rate (PTTR), relative to the ridership at a baseline travel time rate (BTTR). The suggested baseline travel time rate is 4 min/mi (15 mph), except in the central business districts of metropolitan areas with over 5 million population, in which case it is 6 min/mi (10 mph). (These values can be adjusted by the analyst to reflect local passenger expectations of travel speeds.) Equation 168 shows the calculation of the transit wait-ride score.

**Exhibit 111. Level of service, transit on urban streets.**

TLOS Score	LOS
≤2.00	A
>2.00–2.75	B
>2.75–3.50	C
>3.50–4.25	D
>4.25–5.00	E
>5.00	F

Source: Adapted from HCM (2016), Exhibit 18-3.

$$s_{w-r} = f_h \times f_{ptt} \quad \text{Equation 168}$$

where

$s_{w-r}$  = transit wait-ride score (unitless),  
 $f_h$  = headway factor (unitless), and  
 $f_{ptt}$  = perceived travel time factor (unitless).

The headway factor calculation incorporates assumed ridership elasticities that relate the percentage change in ridership to the percentage change in bus headways. Only the buses and bus routes that actually stop to pick up or drop off passengers within the study section of the street should be included in determining the average bus headway on the street. Express bus service without at least one bus stop on the street would be excluded. Equation 169 is used to calculate the headway factor.

$$f_h = 4 \times \exp(-0.0239h) \quad \text{Equation 169}$$

where

$f_h$  = headway factor (unitless), and  
 $h$  = average number of minutes between buses.

**Perceived Travel Time Factor.** The perceived travel time factor calculation incorporates assumed ridership elasticities that relate the percentage change in ridership to the percentage change in the perceived travel time rate. The perceived travel time rate, in turn, is a function of actual bus speeds (travel time rates) and factors that have been found to make the time spent waiting for or riding on the bus seem longer than the actual time. These factors include late bus arrivals; provision of shelters, benches, or both at bus stops; and crowding on board the bus. The perceived travel time factor is calculated using Equation 170 through Equation 172.

$$f_{ptt} = \frac{[(e-1)BTTR - (e+1)PTTR]}{[(e-1)PTTR - (e+1)BTTR]} \quad \text{Equation 170}$$

$$PTTR = (a_1 \times IVTTR) + (a_2 \times EWTR) - ATR \quad \text{Equation 171}$$

$$IVTTR = \frac{60}{S_{bus}} \quad \text{Equation 172}$$

where

$f_{ptt}$  = perceived travel time factor (unitless),  
 $e$  = ridership elasticity with respect to changes in the travel time rate (unitless), default = -0.40,  
 $BTTR$  = baseline travel time rate (min/mi), default = 6 for the central business district of metropolitan areas with populations of 5 million or greater, and 4 otherwise,  
 $PTTR$  = perceived travel time rate (min/mi),  
 $a_1$  = travel time perception coefficient for passenger load (unitless) = 1.00 when 80% or fewer of seats are occupied, 1.19 when all seats are occupied, and 1.42 with a standing load equal to 25% of the seating capacity; HCM Equation 18-59 can also be used,  
 $IVTTR$  = in-vehicle travel time rate (min/mi),  
 $a_2$  = travel time perception coefficient for excess wait time (unitless), default = 2.0,  
 $EWTR$  = excess wait time rate (min/mi) = (average wait for buses beyond the scheduled arrival time)/(average passenger trip length), default = 0.8, and

$ATR = \text{amenity time rate (min/mi)} = (\text{perceived wait time reduction due to bus stop amenities}) / (\text{average passenger trip length})$ ; default = 0.1 (bench provided), 0.3 (shelter only), and 0.4 (shelter and bench).

When field measurement of average bus speeds along the street is not feasible, the in-vehicle travel time rate can be estimated from the bus schedule as the travel time between timepoints on either side of the study section, divided by the on-street distance between the timepoints. The bus speed estimation procedure presented earlier can also be used.

The excess wait time is the average difference between the scheduled and actual arrival times for buses at the timepoint prior to the study section. For example, if buses arrive 3 minutes behind schedule on average at the timepoint, the excess wait time is 3 minutes. An early arrival at the timepoint without a corresponding early departure is treated as 0 minutes of excess wait time, but an early arrival combined with an early departure is counted as being one headway late.

**Special Cases.** This section gives guidance on the analysis of special cases.

**Gaps in Transit Service.** The portions of street where there is no transit service should be split into their own segments for the purpose of transit LOS analysis (if not already split for other reasons). The transit LOS should be set at F for these segments. The rest of the transit LOS analysis proceeds normally, with the overall transit LOS being a length-weighted average including the segments with no transit service.

**No Through Transit Service for the Full Length of the Study Facility.** The TLOS score is measured on a segment-by-segment basis and reflects in part actions that a roadway agency can take to improve bus speeds. It also reflects the amount of bus service provided within a given segment. It can be compared on a segment-by-segment basis to the LOS scores available for other travel modes, reflecting the quality of service provided within that segment. In this respect, it does not measure origin–destination service quality for transit passengers. Therefore, by default, no adjustment is made to the score if passengers would need to transfer from one route to another to make a complete trip through the study facility.

However, if the analyst is interested in measuring origin–destination service quality along a facility, one option would be to calculate the TLOS score as described above, but (1) double the assumed average trip length to reflect the linked (i.e., involving a transfer) trip, and (2) add a perceived transfer time rate equal to the average transfer time multiplied by a perceived waiting time factor (suggested default = 2) and divided by the average trip length.

**Single-Direction Transit Service on a Two-Way Street.** The direction of travel for which there is no transit service is assigned transit LOS F. The other direction of travel is evaluated normally.

**Bus Lanes and Bus Streets.** The methodologies are not specifically designed to handle bus streets and bus lanes, but with some judicious adjustments, they can be adapted to these special situations.

In the case of bus streets, the auto LOS is, by definition, LOS F (since autos cannot access this street). The transit, bicycle, and pedestrian LOS are computed normally, with transit vehicles being the only motorized vehicles on the street.

In the case of bus lanes, the auto, transit, bicycle, and pedestrian LOS analyses proceed normally. The only difference is that only transit vehicles (and carpools, if allowed) are assigned to the bus lane.

### Simplifications from the HCM

The HCM method for estimating transit level of service for urban streets is documented in HCM Chapters 16 (Urban Street Facilities), 18 (Urban Street Segments), and 19 (Signalized Intersections). The transit LOS method presented above makes the following simplifications to the HCM method to improve its utility for planning applications:

- Bus running speeds are based solely on bus acceleration and deceleration characteristics rather than on motor vehicle running speeds (which are discounted in the HCM for midblock interference along the street segment).
- Bus stop delay is not adjusted for the location of the bus stop (e.g., near-side or far-side).
- Bus stop re-entry delay is not computed.
- Default values are provided for the  $a_1$  passenger load travel time perception factor in lieu of the HCM equation that uses the exact passenger load as an input.
- A default value of 3 minutes excess wait time was used in lieu of computing it from on-time arrival statistics.

To take full advantage of these features the analyst must apply the HCM method as described in HCM Chapter 18, applying defaults as needed.

## 5. Signalized Intersections

### Pedestrians

The HCM provides two pedestrian performance measures suitable for planning analyses of signalized intersections: average pedestrian delay and a pedestrian LOS score that reflects pedestrian comfort while crossing an intersection. Exhibit 112 lists the data required for these mea-

**Exhibit 112. Required data for signalized intersection pedestrian analysis.**

Input Data (units)	Used By		Default Value
	DEL	PLOS	
Traffic signal cycle length (s)*	•	•	60 (CBD), 120 (suburban)
Major street walk time (s)	•	•	See Section L or use 19 (CBD), 31 (suburban), 7 (minimum)
Minor street walk time (s)	•	•	See Section L or use 19 (CBD), 7 (suburban), 7 (minimum)
Number of lanes crossed on minor street crosswalk*		•	Must be provided
Number of channelizing islands crossed on minor street crosswalk		•	0
15-minute volume on major street (veh)*		•	Must be provided
Number of major street through lanes in the direction of travel*		•	Must be provided
Mid-block 85th percentile speed on major street (mph)		•	Posted speed limit
Right-turn on red flow rate over the minor street crosswalk (veh/h)		•	0 (right turns on red prohibited) Must be provided (otherwise)
Permitted left-turn volume over the minor street crosswalk (veh/h)		•	0 (protected left-turn phasing) 10% of through 15-minute volume (permitted left-turn phasing) 5% of through 15-minute volume (protected-permitted left-turn phasing)

Notes: See HCM Chapter 19 for definitions of the required input data.

DEL = delay, PLOS = pedestrian level of service, CBD = central business district.

\*Input data used by or calculation output from the HCM urban street automobile LOS method.

asures and provides suggested default values. The HCM also provides calculation methods for assessing intersection corner circulation area and crosswalk circulation area, but these typically require more detailed data than would be available for a planning analysis.

### Pedestrian Delay

Average pedestrian delay for a given signalized crosswalk is calculated as follows:

$$d_p = \frac{(C - g_{walk})^2}{2C} \tag{Equation 173}$$

where

- $d_p$  = average pedestrian delay (s),
- $C$  = cycle length (s), and
- $g_{walk}$  = effective walk time for the crosswalk (s).

### Pedestrian LOS Score

The HCM provides a method (Equations 19-71 through 19-76 in Chapter 19, Signalized Intersections) for calculating a pedestrian LOS score (and associated LOS letter using HCM Exhibit 19-9) for signalized intersections. This score can be used on its own or integrated into the urban street pedestrian LOS procedures. Most of the method’s inputs are required by the auto LOS method for signalized intersections or can be defaulted. An exception is the right-turn-on-red flow rate over the crosswalk being analyzed. The LOS score is sensitive to this input and a wide range of values are possible. The HCM recommends developing local default values for this variable for use in planning analyses.

## Bicycles

The HCM provides two bicycle performance measures for signalized intersections: average bicycle delay and a bicycle LOS score that reflects bicyclist comfort while crossing an intersection. Exhibit 113 lists the data required for these measures and provides suggested default values.

**Exhibit 113. Required data for signalized intersection bicycle analysis.**

Input Data (units)	Used By		Default Value
	DEL	BLOS	
Traffic signal cycle length (s)*	•		60 (CBD), 120 (suburban)
Effective green time for bicycles (s)	•		Effective green time for parallel through automobile traffic*
15-minute bicycle flow rate (bicycles/h)	•		Must be provided
15-minute automobile flow rate (veh/h)*		•	Must be provided
Cross street width (ft)		•	Must be provided
Bicycle lane width (ft)		•	5 (if provided)
Outside lane width (ft)*		•	12
Shoulder/parking lane width (ft)		•	1.5 (curb and gutter only) 8 (parking lane provided)
Percentage of intersection approach and departure with occupied on-street parking (decimal)		•	0.00 (no parking lane) 0.50 (parking lane provided)
Number of parallel through lanes (shared or exclusive)*		•	Must be provided

Notes: See HCM Chapter 19 for definitions of the required input data.

DEL = delay, BLOS = bicycle level of service, CBD = central business district.

\*Input data used by or calculation output from the HCM urban street automobile LOS method.

**Bicycle Delay**

When bicyclists share the lane with automobile traffic, bicyclist delay is the same as automobile delay and can be calculated using Equation 97 (see Section L5). When bicyclists have their own lane, bicycle delay is calculated as follows:

$$d_b = \frac{0.5C(1 - g_b/C)^2}{1 - \min\left[\frac{v_{bic}}{c_b}, 1.0\right] \frac{g_b}{C}} \tag{Equation 174}$$

$$c_b = s_b \frac{g_b}{C} \tag{Equation 175}$$

where

- $d_b$  = average bicycle delay (s),
- $g_b$  = effective green time for the bicycle lane (s),
- $C$  = cycle length (s),
- $v_{bic}$  = bicycle flow rate (bicycles/h),
- $c_b$  = bicycle lane capacity (bicycles/h), and
- $s_b$  = bicycle lane saturation flow rate (bicycles/h) = 2,000.

**Bicycle LOS Score**

The HCM provides a method (Equations 19-79 through 19-82) for calculating a bicycle LOS score (and associated LOS letter using HCM Exhibit 19-9) for signalized intersections. This score can be used on its own or integrated into the urban street bicycle LOS procedures. Most of the method’s inputs are required by the auto LOS method for signalized intersections or can be defaulted.

**Transit**

The HCM does not provide a transit LOS score for signalized intersections; the impacts of signalized intersections on bus speeds are incorporated into the segment and facility LOS scores (see Section O4).

**6. STOP-CONTROLLED INTERSECTIONS**

**Pedestrians**

*Two-Way Stops and Midblock Crossings*

The HCM 2016 provides a method for estimating pedestrian delay crossing the major street at two-way STOP-controlled intersections and at midblock crosswalks. Exhibit 114 lists the required data.

**Exhibit 114. Required data for two-way STOP-controlled intersection pedestrian delay calculation.**

Input Data (units)	Default Value
Crosswalk length (ft)	Must be provided
Average pedestrian walking speed (ft/s)	3.5
Pedestrian start-up time and end clearance time (s)	3
Number of through lanes crossed	Must be provided
Vehicle flow rate during the peak 15 min (veh/s)	Must be provided; note the units of veh/s

Note: See HCM Chapter 20 for definitions of the required input data.



When a pedestrian refuge area is available in the street median, pedestrians can cross the street in two stages. In this case, delay should be calculated separately for each stage of the crossing and totaled to determine the overall delay.

First, pedestrian delay is calculated for the scenario in which motorists do not yield to pedestrians (i.e., pedestrians must wait for a suitable gap in traffic). This calculation neglects the additional delay that occurs when pedestrian crossing volumes are high enough that pedestrian platoons form (i.e., some pedestrians have to wait for the pedestrians ahead of them to step off the curb before they can enter the crosswalk). The following equations are used:

$$t_c = \frac{L}{S_p} + t_s \quad \text{Equation 176}$$

$$P_b = 1 - e^{-\frac{t_c v}{N_L}} \quad \text{Equation 177}$$

$$P_d = 1 - (1 - P_b)^{N_L} \quad \text{Equation 178}$$

$$d_g = \frac{1}{v}(e^{vt_c} - vt_c - 1) \quad \text{Equation 179}$$

$$d_{gd} = \frac{d_g}{P_d} \quad \text{Equation 180}$$

where

- $t_c$  = critical headway for a single pedestrian (s),
- $S_p$  = average pedestrian walking speed (ft/s),
- $L$  = crosswalk length (ft),
- $t_s$  = pedestrian start-up time and end clearance time (s),
- $P_b$  = probability of a blocked lane (i.e., an approaching vehicle at the time the pedestrian arrives at the crosswalk that prevents an immediate crossing),
- $P_d$  = probability of a delayed crossing,
- $N_L$  = number of through lanes crossed,
- $v$  = vehicular flow rate (veh/s),
- $d_g$  = average pedestrian gap delay (s), and
- $d_{gd}$  = average gap delay for pedestrians who incur nonzero delay.

When motorists yield to pedestrians, pedestrian delay is reduced. The average pedestrian delay in this scenario is calculated as follows:

$$d_p = \sum_{i=1}^n h(i - 0.5)P(Y_i) + \left( P_d - \sum_{i=1}^n P(Y_i) \right) d_{gd} \quad \text{Equation 181}$$

where

- $d_p$  = average pedestrian delay (s),
- $i$  = sequence of vehicle arrivals after the pedestrian arrives at the crosswalk,
- $n$  = average number of vehicle arrivals before an adequate gap is available =  $\text{Int}(d_{gd}/h)$ ,
- $h$  = average vehicle headway for each through lane (s),
- $P_d$  = probability of a delayed crossing,
- $P(Y_i)$  = probability that motorist  $i$  yields to the pedestrian, from Exhibit 115, and
- $d_{gd}$  = average gap delay for pedestrians who incur nonzero delay.

The motorist yielding rate  $M_y$  is an input to the equations in Exhibit 115, and all other variables in the exhibit are as defined previously. Yielding rates for a selection of pedestrian crossing treatments are given in Exhibit 20-24 in HCM Chapter 20, Two-Way STOP-controlled Intersections. Alternatively, local values can be developed from field observations.

**Exhibit 115. Equations for calculating probability of vehicles yielding to a crossing pedestrian.**

Lanes Crossed	Probability of Vehicle <i>i</i> Yielding	
1	$P(Y_i) = P_d M_y (1 - M_y)^{i-1}$	Equation 182
2	$P(Y_i) = \left[ P_d - \sum_{j=0}^{i-1} P(Y_j) \right] \left[ \frac{(2P_b[1 - P_b]M_y) + (P_b^2 M_y^2)}{P_d} \right]$	Equation 183
3	$P(Y_i) = \left[ P_d - \sum_{j=0}^{i-1} P(Y_j) \right] \left[ \frac{P_b^3 M_y^3 + 3P_b^2(1 - P_b)M_y^2 + 3P_b(1 - P_b)^2 M_y}{P_d} \right]$	Equation 184
4	$P(Y_i) = \left[ P_d - \sum_{j=0}^{i-1} P(Y_j) \right] \times \left[ \frac{P_b^4 M_y^4 + 4P_b^3(1 - P_b)M_y^3 + 6P_b^2(1 - P_b)^2 M_y^2 + 4P_b(1 - P_b)^3 M_y}{P_d} \right]$	Equation 185

### All-Way Stops

The HCM 2016 provides a qualitative discussion of contributors to pedestrian delay at all-way STOP-controlled intersections. However, the research base does not exist to provide a calculation method.

### Bicycles

The HCM 2016 provides qualitative discussions of bicycle delay at two-way and all-way STOP-controlled intersections. However, the research base does not exist to provide calculation methods.

### Transit

Buses will experience the same amount of control delay as other motor vehicles at these intersections.

## 7. Roundabouts

Pedestrian delay at roundabouts can be estimated using the methods for two-way STOP-controlled intersections (see Section O6). The HCM provides no quantitative method for estimating bicycle delay, although it can be expected to be similar to vehicular delay, if bicyclists circulate as vehicles, or to pedestrian delay, if bicyclists dismount and use the crosswalks. Buses will experience the same amount of control delay as other motor vehicles.

## 8. Off-Street Pathways

The HCM 2016 provides LOS measures for three combinations of modes and facility types:

- Pedestrians on an exclusive off-street pedestrian facility,
- Pedestrians on a shared-use path, and
- Bicyclists on an exclusive or shared off-street facility.

Exhibit 116 lists the required data for analyzing each of these situations.

**Exhibit 116. Required data for off-street pathway analysis.**

Input Data (units)	Used By			Default Value
	PEX	PSH	BIKE	
Facility width (ft)	•		•	Must be provided
Effective facility width (ft)	•			Same as facility width
Pedestrian volume (ped/h)	•			Must be provided
Bicycle volume (bicycles/h)		•		Must be provided
Total path volume (p/h)			•	Must be provided
Bicycle mode split (%)			•	55% of path volume
Pedestrian mode split (%)			•	20% of path volume
Runner mode split (%)			•	10% of path volume
Inline skater mode split (%)			•	10% of path volume
Child bicyclist mode split (%)			•	5% of path volume
Peak hour factor (decimal)	•	•	•	0.85
Directional volume split (decimal)		•	•	0.50
Average pedestrian speed (ft/min)	•			300
Average pedestrian speed (mph)		•	•	3.4
Average bicycle speed (mph)		•	•	12.8
Average runner speed (mph)			•	6.5
Average inline skater speed (mph)			•	10.1
Average child bicyclist speed (mph)			•	7.9
SD of pedestrian speed (mph)			•	0.6
SD of bicycle speed (mph)			•	3.4
SD of runner speed (mph)			•	1.2
SD of inline skater speed (mph)			•	2.7
SD of child bicyclist speed (mph)			•	1.9
Segment length (mi)			•	Must be provided
Walkway grade ≤ 5% (yes/no)	•			Yes
Pedestrian flow type (random/platooned)	•			Random
Centerline stripe presence (yes/no)			•	No

Source: Default values from Hummer et al. (2006), except for effective facility width.

Notes: See HCM Chapter 24 for definitions of the required input data.

PEX = pedestrian LOS on an exclusive path, PSH = pedestrian LOS on a shared path, BIKE = bicycle LOS on all types of off-street pathways, SD = standard deviation.

### Pedestrians on an Exclusive Off-Street Facility

Pedestrian LOS on an exclusive facility is based on the average space available to pedestrians. It is calculated using the following three equations:

$$v_{15} = \frac{v_h}{4 \times PHF} \tag{Equation 186}$$

$$v_p = \frac{v_{15}}{15 \times W_E} \tag{Equation 187}$$

$$A_p = \frac{S_p}{v_p} \tag{Equation 188}$$

where

- $v_{15}$  = pedestrian flow rate during peak 15 min (p/h),
- $v_h$  = pedestrian demand during analysis hour (p/h),
- $PHF$  = peak hour factor,
- $v_p$  = pedestrian flow per unit width (p/ft/min),
- $W_E$  = effective facility width (ft),

$A_p$  = average pedestrian space (ft<sup>2</sup>/p), and  
 $S_p$  = average pedestrian speed (ft/min).

Average pedestrian space is converted into an LOS letter using Exhibit 24-1 (for random pedestrian flow) or Exhibit 24-2 (when pedestrian platoons form) in HCM Chapter 24, Off-Street Pedestrian and Bicycle Facilities. HCM Exhibit 24-18 can be used to estimate the reduction in average pedestrian speed that occurs when walkway grades exceed 5%. The LOS result is highly sensitive to the average pedestrian speed provided as an input.

### Pedestrians on a Shared Off-Street Facility

Pedestrian LOS on a shared off-street facility is based on the number of times per hour an average pedestrian meets or is passed by bicyclists using the path. The weighted number of meeting and passing events is calculated as follows:

$$F_p = \frac{Q_{sb}}{PHF} \left( 1 - \frac{S_p}{S_b} \right) \quad \text{Equation 189}$$

$$F_m = \frac{Q_{ob}}{PHF} \left( 1 + \frac{S_p}{S_b} \right) \quad \text{Equation 190}$$

$$F = (F_p + 0.5F_m) \quad \text{Equation 191}$$

where

$F_p$  = number of passing events (events/h),  
 $F_m$  = number of meeting events (events/h),  
 $Q_{sb}$  = bicycle demand in same direction (bicycles/h),  
 $Q_{ob}$  = bicycle demand in opposing direction (bicycles/h),  
 $PHF$  = peak hour factor,  
 $S_p$  = mean pedestrian speed on path (mph),  
 $S_b$  = mean bicycle speed on path (mph), and  
 $F$  = weighted total events on path (events/h).

The weighted total events  $F$  is converted into an LOS letter using HCM Exhibit 24-4. The LOS result is sensitive to the peak hour factor provided as an input.

### Bicyclists on an Off-Street Facility

Bicycle LOS on all types of off-street facilities is based on a bicycle LOS score that considers:

- The average number of times per minute a bicyclist meets or is overtaken by other path users,
- The path width,
- The presence or absence of a centerline stripe, and
- The average number of times per minute a bicyclist is delayed in passing another path user (for example, because an oncoming path user is in the way).

At a minimum, total path width and the total number of hourly path users must be provided, although results will be more accurate if the actual mode split of path users (bicyclists, pedestrians, runners, inline skaters, and child bicyclists) is known or can be defaulted using local values. The bicycle LOS score is particularly sensitive to the bicycle mode split, the peak hour factor, and the directional distribution provided as inputs, and somewhat sensitive to whether or not a centerline stripe is present. HCM Exhibit 24-5 is used to convert the bicycle LOS score into an LOS letter.

The calculation process requires a large number of computations, and the use of a computational engine is recommended. The FHWA project (Hummer et al. 2006) that developed the method developed an engine, which can be downloaded from <http://www.fhwa.dot.gov/publications/research/safety/pedbike/05138/SharedUsePathsTLOSCalculator.xls>. The FHWA computational engine applies the peak hour factor in a different order in the computational sequence than the HCM implementation of the method does. However, any difference between the two methods is negligible for planning purposes.

## 9. References

- Hall, R. A. HPE's Walkability Index—Quantifying the Pedestrian Experience. *Compendium of Technical Papers*, ITE 2010 Technical Conference and Exhibit, Savannah, Ga., March 2010.
- Highway Capacity Manual: A Guide to Multimodal Mobility Analysis*. 6th ed. Transportation Research Board, Washington, D.C., 2016.
- Hummer, J. E., N. M. Roupail, J. L. Toole, R. S. Patten, R. J. Schneider, J. S. Green, R. G. Hughes, and S. J. Fain. *Evaluation of Safety, Design, and Operation of Shared-Use Paths—Final Report*. Report FHWA-HRT-05-137. Federal Highway Administration, Washington, D.C., July 2006.
- Kittelson & Associates, Inc., Parsons Brinckerhoff, KFH Group, Inc., Texas A&M Transportation Institute, and Arup. *TCRP Report 165: Transit Capacity and Quality of Service Manual*, 3rd Edition. Transportation Research Board of the National Academies, Washington, D.C., 2013.
- San Francisco Department of Public Health. *Bicycle Environmental Quality Index (BEQI) Draft Report*. San Francisco, Calif., June 2009.



## P. Truck Level of Service



### 1. Overview

The HCM does not provide a truck LOS measure. However, *NCFRP Report 31* (Dowling et al. 2014) does provide a truck LOS measure, which is presented in this section.

### 2. Truck Level of Service Index

Truck LOS is defined as a measure of the quality of service provided by a facility for truck hauling of freight as perceived by shippers and carriers. It is measured in terms of the percentage of ideal conditions achieved by the facility for truck operations. A logistic function is used to compute the percentage of ideal conditions achieved by the facility for truck operations.

$$\%TLOS = \frac{1}{(1 + 0.10e^{-200U(x)})} \quad \text{Equation 192}$$

where

$\%TLOS$  = truck LOS index as a percentage of ideal conditions (decimal),  
 $U(x)$  = truck utility function, and  
 $e$  = exponential function.

Ideal conditions are defined as a facility usable by trucks with legal size and weight loads, with no at-grade railroad crossings, that provides reliable truck travel at truck free-flow speeds, at low cost (i.e., no tolls).

Reliable performance is defined as 100% probability of on-time arrival for the truck. A facility is considered to deliver 100% probability of on-time arrival as long as its travel time index for trucks falls below 1.33 for uninterrupted-flow facilities (i.e., freeways and highways) and 3.33 for interrupted-flow facilities (i.e., streets and highways with signals, roundabouts, or stop control no more than 2 miles apart). (These values are approximately the automobile LOS E/F thresholds for these facility types.) The truck travel time index is the ratio of the truck free-flow speed to the actual truck speed.

Truck free-flow speed is defined as the maximum sustainable speed that an average truck can achieve under low traffic flow conditions given the prevailing grades, exclusive of intersection delays.

### Truck Utility Function

A truck utility function is used for computing the truck LOS index.

$$U(x) = A \times (POTA - 1) + B \times (TTI - 1) + C \times (Toll/mi) + D \times (TFI - 1) \quad \text{Equation 193}$$

where

$U(x)$  = utility of facility for truck shipments,

$A$  = weighting parameter for reliability, sensitive to shipping distance =  $5 / ASL$ ,

$ASL$  = average shipment length (mi) = 200 mi (lower 48 states), 280 mi (Alaska), and 30 mi (Hawaii),

$B$  = weighting parameter for shipment time, sensitive to free-flow speed =  $-0.32 / FFS$ ,  
 $FFS$  = free-flow speed,

$C$  = weighting parameter for shipment cost =  $-0.01$ ,

$D$  = weighting parameter for the facility's truck friendliness = 0.03,

$POTA$  = probability of on-time arrival = 1 if the mixed flow (autos and trucks) travel time index is  $\leq 1.33$  (freeways and highways) or  $\leq 3.33$  (urban streets),

$TTI$  = truck travel time index for the study period, the ratio of truck free-flow speed to actual truck speed,

$Toll/mi$  = truck toll rate (dollars per mile), a truck volume-weighted average for all truck types, and

$TFI$  = truck friendliness index, where 1.00 = no constraints or obstacles to legal truck load and vehicle usage of facility and 0.00 = no trucks can use the facility.

The truck friendliness index for a facility can be reduced below 1.00 at an agency's discretion to reflect the effects of restrictions on truck load, length, width, height, turning radius, or a combination of these (Dowling et al. 2014). The utility function is weighted so that truck friendliness indices of 0.60 or less will always result in LOS F, regardless of a facility's speed or reliability.

Note that the utility function is designed to work with data on the truck's experience: probability of on-time arrival for the truck shipment, the travel time index for trucks, tolls paid by trucks, and the truck friendliness index. For many of these data, the HCM and this Guide provide methods only for estimating mixed flow (auto and truck) speeds and reliability. Until truck specific performance estimation procedures become available, the analyst must decide if the mixed flow results produced by the HCM and this Guide are applicable to trucks, and whether or not to apply an adjustment to the mixed flow performance to obtain truck specific performance for the purposes of estimating truck LOS.

### Truck LOS Thresholds

The truck LOS index is the ratio of the utility for actual conditions over the utility for ideal conditions. The truck LOS index is converted into an equivalent letter grade based on its freight facility class, according to the thresholds given in Exhibit 117. The thresholds for a given letter grade are higher for the higher class facilities.

MAP-21, the Moving Ahead for Progress in the 21st Century Act, requires the Department of Transportation to establish a national freight network to assist states in strategically directing resources toward improved movement of freight on highways (Federal Register 2013). At the

**Exhibit 117. Truck LOS thresholds by truck LOS index and freight facility class.**

LOS	Class I (Primary Freight Facility)	Class II (Secondary Facility)	Class III (Tertiary Facility)
A	≥90%	≥85%	≥80%
B	≥80%	≥75%	≥70%
C	≥70%	≥65%	≥60%
D	≥60%	≥55%	≥50%
E	≥50%	≥45%	≥40%
F	<50%	<45%	<40%

**Exhibit 118. Facility freight classification system.**

Facility Class	Description	Suggested Criteria	Examples
<b>Class I</b>	Highway facility critical to the inter-regional or within region movement of goods.	<ul style="list-style-type: none"> <li>Facility carries a high volume of goods by truck (by tonnage or by value).</li> <li>Trucks may account for a high volume or percentage of AADT compared to other facilities in the region.</li> </ul>	Interstate freeway, inter-regional rural principal arterial.
<b>Class II</b>	Highway facility of secondary importance to goods movement within or between regions.	<ul style="list-style-type: none"> <li>Facility carries lesser volumes of goods (by tonnage or value).</li> <li>Trucks account for a lesser volume or percentage of AADT.</li> </ul>	Urban principal arterial, connector to major intermodal facilities (maritime port, intermodal rail terminal, airports).
<b>Class III</b>	Highway facility of tertiary importance to goods movement within or between regions.	<ul style="list-style-type: none"> <li>Connectors to significant single origins/destinations of goods, such as major manufacturing facilities, sources of raw materials (mines, oil, etc.).</li> <li>Connectors to truck service facilities and terminals.</li> </ul>	Access roads to mines, energy production facilities, factories, truck stops, truck terminals.

Note: AADT = annual average daily traffic.

time of writing, guidelines on establishing freight facility classes had not yet been developed. Until these guidelines are set, Exhibit 118 provides a tentative three-class system that employs some of the general criteria outlined in MAP-21 for classifying highway facilities by their relative importance to the regional and national economy.

**3. Estimating Probability of On-Time Arrival from TTI**

If the cumulative distribution of travel time indices for the facility is available, it is a simple matter for the analyst to read the probability of on-time arrival for any selected on-time arrival threshold (for example, the threshold might be defined as 1.33 times the free-flow travel time).

If only the median (50th percentile) and 95th percentile travel time index (TTI) are available to the analyst, then the probability of on-time arrival (POTA) can be estimated through extrapolation. Straight-line extrapolation is used if the 95th percentile TTI is  $\leq 1.33$  (freeways) or  $\leq 3.33$  (urban streets); otherwise, the value is determined by interpolating between the 50th and 95th percentile TTIs.

For example, if one is evaluating the probability of on-time arrival for a freeway, the selected target TTI is 1.33 (for mixed auto and truck traffic). That is the threshold above which the freeway is congested (i.e., speeds are below the speed at capacity). If the 50% TTI is 1.10 and the 95% TTI is 5.00, then the probability of on-time arrival is 53%, computed as follows:

$$POTA = 50\% + (95\% - 50\%) \times \frac{(1.33 - 1.10)}{(5.00 - 1.10)} \tag{Equation 194}$$

**4. A Service-TTI Lookup Table for Truck LOS**

The estimation of truck level of service can be expedited by estimating the average peak hour mixed auto and truck speed. After making an adjustment to the mixed traffic speed to get the truck speed, one can apply Equation 192 to estimate the 95th percentile peak hour speed for trucks. From this information, plus other assumed defaults, one can then construct a “Service-TTI” look-up table.

$$TTI_{95} = 1 + 3.67 \times \ln(TTI_m) \tag{Equation 195}$$



The average peak hour truck TTI is estimated from the peak hour auto speed by applying a local adjustment factor  $f_{LA}$  to reflect local driving characteristics. This factor might apply, for example, if the truck speed limit is set lower than the auto speed limit and trucks comply with the lower limit, or where extended upgrades reduce truck speeds significantly below auto speeds. Otherwise, a default value of 1.00 can be used for  $f_{LA}$ .

$$TTI(\text{truck}) = TTI(\text{mixed}) \times f_{LA} \tag{Equation 196}$$

where

$TTI(\text{truck})$  = truck travel time index,

$TTI(\text{mixed})$  = ratio of the free-flow speed to the actual speed for mixed auto and truck traffic, and

$f_{LA}$  = the local adjustment factor to account for local truck driving behavior (decimal).

The analyst enters Exhibit 119 for the appropriate facility type and (for urban streets only) free-flow speed using the computed truck TTI for average peak hour conditions. Interpolation in the table is allowed. The table shows the estimated 95th percentile TTI, the

**Exhibit 119. Truck TTI level of service look-up table.**

Facility Type	Truck TTI	95% TTI	POTA	Utility	%TLOS	Freight Facility Class			
						Class I	Class II	Class III	
Freeways and Rural Highways	1.05	1.18	99.83%	0.000	90.39%	A	A	A	
	1.10	1.35	93.77%	-0.002	86.81%	B	A	A	
	1.15	1.51	81.16%	-0.006	76.86%	C	B	B	
	1.20	1.67	69.34%	-0.009	63.56%	D	D	C	
	1.25	1.82	60.20%	-0.011	51.15%	E	E	D	
	1.30	1.96	53.33%	-0.013	41.31%	F	F	E	
	1.35	2.10	48.04%	-0.015	33.88%	F	F	F	
	1.40	2.23	43.86%	-0.016	28.27%	F	F	F	
Signalized Urban Streets	FFS = 55 mph	1.20	1.67	100.00%	-0.001	88.79%	B	A	A
		1.40	2.23	99.89%	-0.002	86.20%	B	A	A
		1.60	2.72	98.93%	-0.004	82.51%	B	B	A
		1.80	3.16	96.51%	-0.006	76.80%	C	B	B
		2.00	3.54	92.67%	-0.008	68.40%	D	C	C
		2.20	3.89	87.70%	-0.010	57.23%	E	D	D
		2.40	4.21	81.91%	-0.013	44.25%	F	F	E
	FFS = 45 mph	1.20	1.67	100.00%	-0.001	88.27%	B	A	A
		1.40	2.23	99.89%	-0.003	84.92%	B	A	A
		1.60	2.72	98.93%	-0.005	80.15%	B	B	A
		1.80	3.16	96.51%	-0.007	72.91%	C	C	B
		2.00	3.54	92.67%	-0.009	62.57%	D	D	C
		2.20	3.89	87.70%	-0.012	49.53%	F	E	E
		2.40	4.21	81.91%	-0.014	35.60%	F	F	F
FFS = 35 mph	1.20	1.67	100.00%	-0.002	87.40%	B	A	A	
	1.40	2.23	99.89%	-0.004	82.72%	B	B	A	
	1.60	2.72	98.93%	-0.006	75.99%	C	B	B	
	1.80	3.16	96.51%	-0.008	66.04%	D	C	C	
	2.00	3.54	92.67%	-0.011	52.68%	E	E	D	
	2.20	3.89	87.70%	-0.014	37.60%	F	F	F	
	2.40	4.21	81.91%	-0.017	23.83%	F	F	F	

Notes: TTI = travel time index, the ratio of the free-flow speed to the actual speed; POTA = probability on-time arrival; %TLOS = truck LOS index as a percentage of ideal conditions; and FFS = free-flow speed.

estimated probability of on-time arrival (POTA), the estimated utility for trucks, and the %TLOS index. The LOS letter is then read directly from the table for the appropriate freight facility class.

## 5. References

- Dowling, R., G. List, B. Yang, E. Witzke, and A. Flannery. *NCFRP Report 31: Incorporating Truck Analysis into the Highway Capacity Manual*. Transportation Research Board of the National Academies, Washington, D.C., 2014.
- Federal Register. Establishment of the National Freight Network. 78 FR 8686, Feb. 6, 2013.



## PART 3

# High-Level Analyses

The sections in Part 3 of the Guide describe high-level analysis methods that work best when evaluating highway systems at an areawide level. These methods enable the analyst to cover large geographic areas with hundreds of miles of highways very efficiently. The methods presented here can be applied to monitoring existing system performance and to forecasting future performance. Part 3 includes the following content:

- Q. Corridor quick estimation screenline analyses
  - a. Screening for capacity and multimodal LOS hot spots
  - b. Screening alternatives for capacity impacts
- R. Areas and systems
  - a. Computational tools
  - b. Data needs
  - c. Estimation of demand model inputs
  - d. Performance measure estimation
- S. Roadway system monitoring
  - a. Travel time datasets
  - b. Identification of problem spots through the travel time index
  - c. Identification of multimodal problem spots
  - d. Diagnosis of causes of mobility problems



# Q. Corridor Quick Estimation Screenline Analysis

## 1. Overview

Transportation planners assess future investments in a corridor based on the performance of the freeways and streets that make up the corridor transportation system. The performance of the corridor system and its components are often estimated through a travel demand and analysis forecasting process combined with either a microscopic or macroscopic traffic operations model. This process requires a variety of inputs and outputs which the HCM can provide, including capacity, queues, delay, travel speeds, and level of service (LOS). The consistency of default values used across facilities in a corridor should be considered when conducting a corridor analysis.

This section presents a high-level quick estimation method for quickly assessing available corridor capacity. More detailed corridor analyses would employ the high-level methods described next in Section R, or they would employ the medium-level methods described earlier in Part 2.



## 2. Screening for Capacity and Multimodal LOS Hot Spots

For the purposes of quickly screening the corridor for multimodal LOS problem (hot) spots, one can divide the corridor into a set of screenlines where the demands are checked against HCM service volume tables for auto, transit, bicycle, and pedestrian LOS, as illustrated in Exhibit 120.

The screenlines are located by the analyst at key points, particularly choke points in the corridor. For example, in Exhibit 120, Screenlines 1 and 6 are located at key choke points in the corridor with the fewest parallel facilities available to carry traffic. The other screenlines are located at spots where corridor demand may significantly change from section to section (often between freeway interchanges).

The forecasted AADT for each freeway or major surface-street crossing the screenline is compared to the values in the appropriate service volume table for the auto mode to assess whether a facility is likely to operate at a level of service acceptable to the agency. For the non-auto modes, it is necessary to perform specific analyses of the conditions present at the screenline.

Note that the use of screenlines for modal analysis will not catch *intersection* problem spots, so key intersections should be checked as well. The screenline analysis may indicate sections of

**Exhibit 120. Example corridor screenlines.**

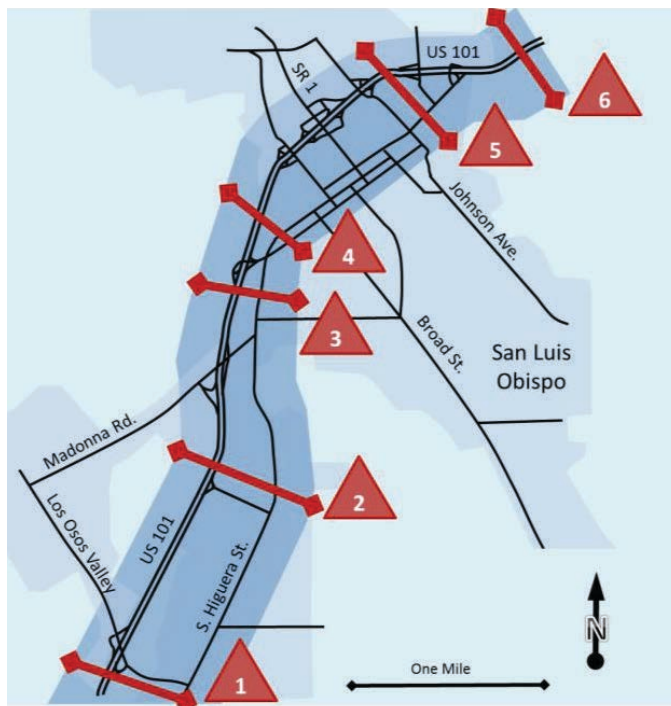

the corridor where high vehicle volumes suggest that the intersections should be checked for potential LOS problems.

Exhibit 121 illustrates a set of corridor screenline checks for the freeway and arterial corridor shown in Exhibit 120.

### 3. Screening Alternatives for Capacity Impacts

A similar screening approach can be used to assess the relative effects of various capacity improvement alternatives on screenline demand-to-capacity ratios and multimodal LOS. Exhibit 122 illustrates such an analysis for the option of adding auxiliary lanes between the two freeway interchanges at screenline #3. The first table shows the before condition. The second table shows the after condition.

In this case, the auxiliary lanes were estimated to increase capacity by 5% (the proportion of traffic on the freeway using the on-ramp and the off-ramp which would be likely to take advantage of the auxiliary lane). The increased capacity will also allow some traffic that currently used the arterial to shift to the freeway. This diversion is estimated to shift about 5% of arterial traffic to the freeway (increasing freeway traffic by 2%). The result is that the auxiliary lanes are estimated to improve the freeway v/c ratio from 105% to 102%, and the arterial v/c ratio from 57% to 54% at Screenline #3.

Note that because the effects being estimated are in the 2% to 5% range, the effects are not rounded to the nearest 100 vehicles per day.

**Exhibit 121. Example corridor screenline volume-to-capacity ratio and LOS checks.**

Screenline	AADT per Lane		Mixed Flow v/c Screening			Multimodal LOS Screening				
	Freeway	Arterial	Freeway	Arterial	Corridor	Freeway		Arterial		
						Auto	Auto	Transit	Bike	Ped
1	16,500	3,300	83%	24%	59%	LOS D	LOS C	LOS F	LOS D	LOS E
2	16,100	4,800	81%	36%	63%	LOS D	LOS C	LOS F	LOS D	LOS E
3	20,900	7,700	105%	57%	86%	LOS F	LOS D	LOS D	LOS E	LOS D
4	16,600	7,600	83%	56%	72%	LOS D	LOS D	LOS D	LOS E	LOS D
5	17,300	3,500	87%	26%	62%	LOS D	LOS C	LOS F	LOS D	LOS E
6	13,900	N/A	70%	N/A	70%	LOS C	N/A	N/A	N/A	N/A

Notes: N/A = not applicable (arterial not present).

Freeway capacity assumed to be 19,900 AADT/lane per Exhibit 19 in Section H4.

Arterial capacity assumed to be 13,500 AADT/lane per Exhibit 46 in Section K4.

Transit, bicycle, and pedestrian LOS would be computed at the screenlines following the defaults given in Section O4 and the procedures given in HCM Chapter 18, Urban Street Segments.

Transit LOS is F at Screenlines 1, 2, and 5 because no transit service is provided outside the city limits.

Bicycle LOS is D outside the city (Screenlines 1, 2, and 5) due to the provision of paved shoulders with no parking. Inside the city, higher traffic volumes and on-street parking contribute to LOS E conditions.

Pedestrian LOS is E outside the city due to the lack of a sidewalk and buffer from traffic. Sidewalks and the presence of on-street parking contribute to LOS D conditions at Screenlines 3 and 4.

**Exhibit 122. Screenline volume-to-capacity analysis of auxiliary lanes.**

Screenline	Demand (AADT/ln)		Capacity (AADT/ln)		Volume-to-Capacity Ratio		
	Freeway	Arterial	Freeway	Arterial	Freeway	Arterial	Corridor
<b>Before</b>							
1	16,500	3,300	19,900	13,500	83%	24%	59%
2	16,100	4,800	19,900	13,500	81%	36%	63%
3	20,900	7,700	19,900	13,500	105%	57%	86%
4	16,600	7,600	19,900	13,500	83%	56%	72%
5	17,300	3,500	19,900	13,500	87%	26%	62%
6	13,900	N/A	19,900	N/A	70%	N/A	70%
<b>After</b>							
1	16,500	3,300	19,900	13,500	83%	24%	59%
2	16,100	4,800	19,900	13,500	81%	36%	63%
3	21,318	7,282	20,895	13,500	102%	54%	83%
4	16,600	7,600	19,900	13,500	83%	56%	72%
5	17,300	3,500	19,900	13,500	87%	26%	62%
6	13,900	N/A	19,900	N/A	70%	N/A	70%

Note: N/A = not applicable (arterial not present).



## R. Areas and Systems

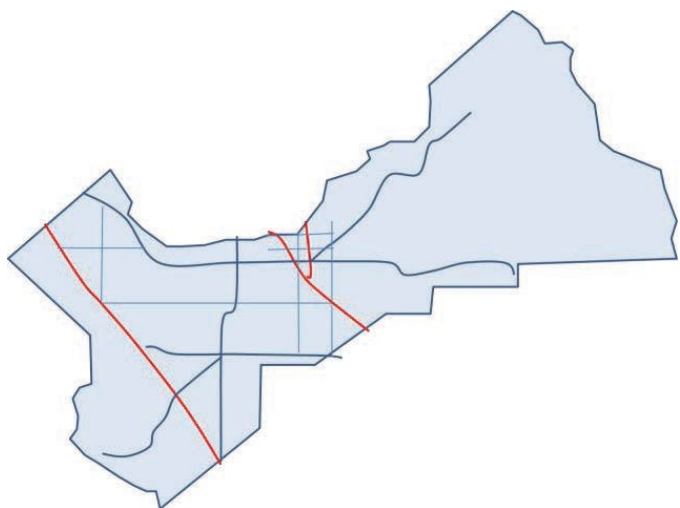

### 1. Overview

Transportation planners assess future investments based on the performance of the freeways and streets that make up a regional transportation system. The performance of the system and its components are often estimated through a travel demand and analysis forecasting process. This process requires a variety of inputs which the HCM can provide, including prediction of travel speeds.

The procedure is performed for all of the highway subsystems in five steps.

1. The necessary input data are assembled,
2. The free-flow speed of the links is computed,
3. The capacity of each link is computed,
4. The mean link speeds are computed, and
5. The travel time and other performance measures are computed for all the links and summed for each subsystem.

Look-up tables of capacity and free-flow speed defaults can be used to shortcut two of the steps (Steps 2 and 3), but poor choice of capacities, free-flow speeds, or both can significantly reduce the accuracy of the speeds estimated using this procedure. In addition, the consistency of default values applied to the facilities of the same area type (e.g., urban, rural) within the study area should be considered.

### 2. Computational Tools

Planning analyses of multimodal transportation systems in large areas are best performed in a travel demand modeling environment, which can equilibrate the forecasted demands between facilities and modes based on the forecasted performance. The guidance provided here is on the use of HCM procedures to generate the key performance analysis inputs required by typical demand models. These procedures are generally performed manually with spreadsheet assistance to facilitate and document the calculations.

### 3. Data Needs

Exhibit 123 lists the required input for the analysis of areawide systems of facilities. Individual performance measures may require only a subset of these inputs.

**Exhibit 123. Required roadway segment data for area and roadway systems analysis.**

Input Data (units)	Required to Estimate					Default Value
	FFS	Cap	Spd	Que	Rel	
Facility type	•	•	•	•	•	Defaults by area and facility type
Segment design geometry	•	•	•	•	•	Defaults by area and facility type
Terrain type		•	•	•	•	Must be provided
Percentage heavy vehicles (%)		•	•	•	•	10% (rural), 5% (urban)
Peak hour factor (decimal)		•	•	•	•	0.88 (rural), 0.95 (urban)
CAF for driver pop. (decimal)		•	•	•	•	1.00
Number of directional lanes		•	•	•	•	Must be provided
Segment length (mi)			•	•	•	Must be provided
Directional demand (veh/h)			•	•	•	Output of travel model

Notes: FFS = free-flow speed (mph), Cap = Capacity (veh/h/ln), Spd = Speed (mph), Que = Queue (veh), Rel = travel time reliability.

Facility type = freeway, arterial by control type (e.g., signal, roundabout), multilane highway, or two-lane rural highway.

Segment design geometry varies by facility type but often includes average lane widths, shoulder widths, and access point density.

Terrain type = level, rolling, mountainous.

CAF for driver pop. = capacity adjustment factor for driver population, used to reduce capacities due to unfamiliar drivers.

## 4. Estimation of Demand Model Inputs

The HCM can support the estimation of two key demand model inputs related to the highway network: the free-flow speed of a link and its capacity.

### Free-Flow Speed Estimation

The free-flow speed of a facility is defined as the space mean speed of traffic when volumes are so light that they have negligible effect on speed. Free-flow speed excludes intersection control delay. Options for estimating free-flow speed include the following:

- The best technique for estimating free-flow speed is to measure it in the field under light traffic conditions. Such observations can be obtained for highways on the National Highway System ([http://www.fhwa.dot.gov/planning/national\\_highway\\_system/](http://www.fhwa.dot.gov/planning/national_highway_system/)) from travel time reliability databases such as the National Performance Management Research Data Set ([http://www.ops.fhwa.dot.gov/freight/freight\\_analysis/perform\\_meas/vpds/npmrdsfaqs.htm](http://www.ops.fhwa.dot.gov/freight/freight_analysis/perform_meas/vpds/npmrdsfaqs.htm)). Commercial datasets of travel times and speeds may also be available. One caution is that free-flow speeds must be measured during low-flow conditions when sample sizes may not be large.
- When and where direct observations of free-flow speeds are not available, or are difficult to obtain, the next-best technique is to use the procedures defined in the HCM to estimate the free-flow speeds. Locally developed look-up tables of HCM-estimated free-flow speeds can be generated using default inputs by facility type and area type to automate the process.
- If posted speed limits are available, the posted speed limit may be adjusted by the analyst to estimate the free-flow speed. One approach is to assume the free-flow speed is 5 miles per hour greater than the posted speed limit.

#### Freeway Subsystem

The free-flow speeds for all freeway subsystem links (weaving, merge, diverge, and basic segments for general purpose lanes, and their equivalents for managed lanes) can be measured in the field or estimated using the procedures described in HCM Chapter 12, Basic Freeway and



Multilane Highway Segments (see HCM Equation 12-1). The procedures require information on lane widths, lateral clearances, number of lanes, and interchange spacing. Default values for lane widths and lateral clearance are provided in HCM Exhibit 12-18.

**Rural Highway Subsystem**

The free-flow speeds for two-lane and multilane highway links can be measured in the field or estimated using the procedures described in HCM Chapter 15, Two-Lane Highways (HCM Equation 15-2), and Chapter 12, Basic Freeway and Multilane Highway Segments (HCM Equation 12-1), respectively. The procedures require information on lane widths, lateral clearances, number of lanes, median type, and access point density. Default values for missing data are provided in HCM Exhibit 15-5 for two-lane highways and HCM Exhibit 12-18 for multilane highways.

**Arterial/Collector Urban Street Subsystem**

The free-flow speed for arterial and collector streets can be measured in the field, or estimated using the procedures described in HCM Chapter 18, Urban Street Segments. Default values are provided in HCM Exhibit 18-5. Note that the HCM also defines a “base free-flow speed” (HCM Equation 18-3) which must be converted to “free-flow speed” (HCM Equation 18-5) before it can be used in planning analyses.

**Creating a Look-up Table of Free-Flow Speed Defaults**

The analyst may wish to develop a look-up table of free-flow speeds based upon local surveys and the functional class and the area type in which a link is located in order to simplify the estimation of free-flow speeds. Depending upon local conditions, the analyst may wish to classify links by area type (e.g., downtown, urban, suburban, rural); terrain type (i.e., level, rolling, mountainous); and frontage development types (e.g., commercial, residential, undeveloped). An illustrative example is provided as Exhibit 124.

The accuracy of the speed estimation procedure is highly dependent on the accuracy of the free-flow speed and capacity used in the computations. Great care should be taken in the

**Exhibit 124. Illustrative look-up table of free-flow speed defaults.**

Facility Type	Area Type	Default Free-Flow Speed (mph)
Freeway	Downtown	55
	Urban	60
	Suburban	65
	Rural	70
Arterial	Downtown	25
	Urban	35
	Suburban	45
	Rural	55
Collector	Downtown	25
	Urban	30
	Suburban	35
	Rural	40

Note: Facility types, area types, and default speed values are illustrative. Where the analyst has ready access to link-specific posted speed limits, the method of adding a fixed adjustment (such as 5 mph) to the posted speed limit may be appropriate. Other categories and values may be more appropriate for a particular study area.

creation of local look-up tables so that they accurately reflect the free-flow speeds present in the locality.

### Capacity Estimation

Unlike travel demand models, where a roadway link represents all intersections and segments within the specified length of roadway, the HCM deals with segments (between intersections) and intersections separately, before combining them into a facility analysis. The discussion herein, therefore, combines the separate HCM segment and intersection procedures for estimating capacity into a single “mini-facility” approach able to accommodate the combined effects of segment and intersection capacity on the total link capacity.

In general, a link’s capacity will be determined for demand modeling purposes by the intersection or segment with the lowest through capacity within that link. Options for estimating link capacity include:

- The best technique for estimating capacity is to measure it in the field at the bottleneck.
- Field measurements of capacity are often not feasible, so the next-best technique is to employ the HCM’s procedures. The HCM’s capacities are computed in terms of passenger cars per hour and must be converted to mixed vehicle capacities. This conversion is needed to allow the use of actual vehicular demand values in the queuing and delay calculation steps, rather than passenger car equivalents. The conversion is performed by applying the HCM’s recommended demand adjustment factors to the passenger car capacity. The following equations for freeways, multilane highways, two-lane rural roads, and arterials illustrate the application of the demand adjustment factors to the passenger car capacity.

#### Freeway Subsystem

The following equation, adapted from HCM Equation 12-9 to yield capacity adjustment rather than volume adjustment, is used to compute the mixed vehicle capacity of a freeway link at its critical point. The critical point is the point on the link with the lowest throughput capacity.

$$c = PCCap \times N \times f_{nv} \times PHF \times CAF \tag{Equation 197}$$

where

$c$  = capacity (veh/h),

$PCCap$  = HCM passenger car capacity from Exhibit 125 (pc/h/ln),

$N$  = number of through lanes, ignoring auxiliary and “exit only” lanes,

$f_{nv}$  = heavy vehicle adjustment factor from Equation 14 (freeways) or Equation 38 (multilane highways),

**Exhibit 125. HCM passenger car capacities (pc/h/ln) for freeway general purpose lanes.**

Free-Flow Speed (mph)	Freeway Section Type		
	Basic	Ramp	Weaving
75	2,400	2,400	2,160
70	2,400	2,400	2,160
65	2,350	2,350	2,115
60	2,300	2,300	2,070
55	2,250	2,250	2,025

Source: HCM (2016), Exhibit 12-4.

Note: Table entries are passenger car capacities (pc/h/ln).

**Exhibit 126. HCM passenger car capacities (pc/h/ln) for freeway managed lanes.**

Free-Flow Speed (mph)	Managed Lane Separation Type				
	Continuous Access	Buffer 1	Buffer 2	Barrier 1	Barrier 2
75	1,800	1,700	1,850	1,750	2,100
70	1,750	1,650	1,800	1,700	2,050
65	1,700	1,600	1,750	1,650	2,000
60	1,650	1,550	1,700	1,600	1,950
55	1,600	1,500	1,650	1,550	1,900

Source: HCM (2016), Exhibit 12-11.

Notes: Table entries are passenger car capacities (pc/h/ln).

Continuous access separation allows vehicles to enter or leave the managed lane at any point.

Buffer types separate the managed lane(s) from the general purpose lanes by paint stripes; vehicles can only enter or leave the managed lane(s) at designated points. Buffer 1 provides one managed lane and Buffer 2 provides two managed lanes.

Barrier types separate the managed lane(s) from the general purpose lanes by physical barriers; vehicles can only enter or leave the managed lane(s) at designated points. Barrier 1 provides one managed lane and Barrier 2 provides two managed lanes.

*PHF* = peak hour factor, and

*CAF* = capacity adjustment factor (locally developed and applied to match field measurements of capacity, when available), default is 1.00.

Exhibit 125 provides HCM passenger car capacities for the general purpose lanes within different types of freeway sections. The passenger car capacities are reduced 10% for weaving sections. Exhibit 126 provides HCM passenger car capacities for managed lanes (e.g., carpool or high-occupancy toll lanes) on the basis of the form of separation between the managed and general purpose lanes.

HCM Chapter 12 provides procedures for determining the adjustment factors used in Equation 197. Exhibit 21 in this Guide (Section H5) provides suggested default values for the adjustment factors.

### Rural Multilane Highways

Equation 197 for freeways is also used to compute the mixed vehicle capacity of a multilane highway (i.e., a highway where the traffic signal spacing exceeds 2 miles). Different HCM passenger car capacities are used for multilane highways and the adjustment factors may take on different values. Exhibit 32 in this Guide (Section I5) provides default adjustment factor values that can be used with Equation 197. Exhibit 127 provides the HCM’s passenger car capacities for multilane highways.

**Exhibit 127. HCM passenger car capacities for rural multilane highways.**

Free-Flow Speed (mph)	HCM Passenger Car Capacity (pc/h/ln)
70	2,300
65	2,300
60	2,200
55	2,100
50	2,000
45	1,900

Source: HCM (2016), Exhibit 12-4.

### Rural Two-Lane Highways and Roads

Equation 198 (adapted from HCM Equation 15-3) is used to compute the mixed vehicle capacity in one direction of a two-lane road (one lane each direction) that has traffic signals (or other intersection control such as all-way stops or roundabouts that slow down through movements) spaced more than 2 miles apart.

$$c = PCCap \times f_{hv} \times f_g \times PHF \quad \text{Equation 198}$$

where

$c$  = capacity (veh/h),

$PCCap$  = HCM passenger car capacity = 1,600 for a single direction (pc/h/ln),

$f_g$  = grade adjustment factor for average travel speed (unitless),

$f_{hv}$  = heavy vehicle adjustment factor for average travel speed (unitless) from Equation 48,  
and

$PHF$  = peak hour factor.

Exhibit 38 in this Guide (Section J5) provides suggested default values for percentage of heavy vehicles and peak hour factor. HCM Exhibit 15-9 (grade adjustment factor) and HCM Equation 15-4 (heavy vehicle adjustment factor) are used to compute these factors. To reduce computational effort, the analyst may apply the HCM's adjustment factors for average travel speed, rather than perform a second computation of the adjustments using the HCM's adjustment factors for percent time-spent-following.

### Urban Arterial and Collector Streets

The capacity of an urban arterial or collector street link with multiple choke points (signals, all-way stops, lane drops, roundabouts, etc.) is determined by examining the through movement capacity at each choke point on the arterial link. The choke point with the lowest through capacity determines the overall capacity of the arterial link for demand modeling and high-level planning analysis purposes. (The term "link," as commonly used in demand modeling, refers to a collection of road segments and intersections that are together represented in the model by a single free-flow speed and capacity, and for which the demand model produces a single estimate of demand and average speed.)

Equation 199, adapted for peak hour factor and signal timing adjustments from HCM Equation 19-8, is used to compute the through capacity of one direction of travel at a signal.

$$c = S_o \times N \times f_w \times f_{hvg} \times f_p \times f_{bb} \times f_a \times f_{LU} \times f_{LT} \times f_{RT} \times f_{Lpb} \times f_{Rpb} \times f_{wz} \times f_{ms} \times f_{sp} \times PHF \times (g/C) \quad \text{Equation 199}$$

where

$c$  = capacity (veh/h),

$S_o$  = base saturation flow rate (pc/h/ln) = 1,900 for metropolitan areas with populations of 250,000 or greater and 1,750 otherwise,

$N$  = Number of Lanes in the lane group,

$f_w$  = adjustment factor for lane width (decimal),

$f_{hvg}$  = adjustment factor for combined effect of grade and heavy vehicles in the traffic stream (decimal),

$f_p$  = adjustment factor for existence of a parking lane and parking activity adjacent to lane group (decimal),

$f_{bb}$  = adjustment factor for blocking effect of local buses that stop within intersection area (decimal),  
 $f_a$  = adjustment factor for area type (decimal),  
 $f_{LU}$  = adjustment factor for lane utilization (decimal),  
 $f_{LT}$  = adjustment factor for left-turn vehicle presence in a lane group (decimal),  
 $f_{RT}$  = adjustment factor for right-turn vehicle presence in a lane group (decimal),  
 $f_{Lpb}$  = pedestrian–bicycle adjustment factor for left-turn groups (decimal),  
 $f_{Rpb}$  = pedestrian–bicycle adjustment factor for right-turn groups (decimal),  
 $f_{wz}$  = adjustment factor for work zone at intersection (decimal),  
 $f_{ms}$  = adjustment factor for downstream lane blockage (decimal),  
 $f_{sp}$  = adjustment factor for sustained spillback (decimal),  
 $PHF$  = peak hour factor (decimal), and  
 $g/C$  = ratio of effective green time per cycle.

Exhibit 19-11 in HCM Chapter 19, Signalized Intersections, provides suggested default values for the inputs needed to compute the saturation flow adjustment factors for signalized intersections. For arterials where all-way stops or roundabouts control the link capacity, the procedures in HCM Chapters 21 or 22, respectively, should be used to estimate the through movement capacity at each intersection.

### Capacity Look-up Table

*The accuracy of the speed estimates produced by a demand model are highly dependent on the accuracy of the estimated capacity for the facility.* Consequently, it is recommended that the analyst use capacities that are specific to each link whenever possible. However, it is recognized that this link-specific approach is not feasible when evaluating thousands of links in a metropolitan area. The analyst may select sets of default values for the various capacity adjustment factors that vary by functional class (e.g., freeway, highway, arterial, collector, local), area type (e.g., downtown, urban, suburban, rural), terrain type (i.e., level, rolling, mountainous), and other conditions. These default values may be substituted into the above capacity equations to develop a set of look-up tables of link capacities that vary by functional class, area type, general terrain, and number of lanes.

The effects of the heavy vehicle, constrained geometry, peaking, and other factors generally reduce the base capacity (expressed in terms of passenger cars per hour per lane) by 10% to 20%. The 10% reduction is typical of facilities on level terrain that meet agency design standards, carry modest volumes of heavy vehicles (5% or less), and have typical peak hour factors in the range of 92% to 97%. The 20% reduction is typical of facilities with geometric constraints, relatively high heavy vehicle use, or higher demand peaking.

The saturation flow rates for signalized arterials must be first discounted by the  $g/C$  ratio (percent green time) for the through lanes on the arterial. Research in Florida (Florida DOT 2013) suggests that  $g/C$  ratios of 41% are a practical maximum for suburban arterials with left-turn phases and typical left-turn volumes at major intersections. Higher values may be achieved for the mainline through lanes at intersections without left-turn phases, on one-way streets, and at intersections of major streets with a minor cross street. Other values can be (and should be) selected based on local experience.

Exhibit 128 illustrates the construction of a per-lane capacity look-up table from which the analyst can select capacity values from the 90% and 80% columns depending on the analyst's general assessment of facility conditions. Unique situations may warrant greater capacity reductions than shown in this illustrative table.

**Exhibit 128. Illustrative per-lane capacity look-up table.**

Functional Class	Area or Facility Type	Free-Flow Speed (mph)	Assumed <i>g/C</i>	HCM Capacity (pc/h/ln)	90% HCM Capacity (veh/h/ln)	80% HCM Capacity (veh/h/ln)
Freeway	Downtown	55	N/A	2,250	2,000	1,800
	Urban	60	N/A	2,300	2,100	1,800
	Suburban	65	N/A	2,350	2,100	1,900
	Rural	70	N/A	2,400	2,200	1,900
Arterial	Downtown	25	0.45	860	800	700
	Urban	35	0.45	860	800	700
	Suburban	45	0.41	780	700	600
	Rural Multilane	55	N/A	2,100	1,900	1,700
	Rural Two-lane	55	N/A	1,600	1,400	1,300
Collector	Downtown	25	0.41	780	700	600
	Urban	30	0.41	780	700	600
	Suburban	35	0.37	700	600	600
	Rural Multilane	45	N/A	1,900	1,700	1,500
	Rural Two-lane	45	N/A	1,600	1,400	1,300

Notes: N/A = not applicable.

The 90% and 80% HCM capacity values incorporate 10% or 20% reductions, respectively, from the HCM capacity value, as well as a conversion from passenger car capacity (pc/h/ln) to mixed vehicle capacity (veh/h/ln).

The 90% HCM capacity column is used where the effects of substandard geometry, heavy vehicles, and demand peaking are expected to be negligible to minor. The 80% column is used where these factors are expected to have greater effects on capacity.

Table prepared for a metropolitan area with a population greater than 250,000. Downtown, urban, and suburban arterial and collector values would be reduced by 8% for a smaller metropolitan or urban area.

Downtown, urban, and suburban arterial and collector values can be adjusted for different *g/C* assumptions by the proportion of the analyst's *g/C* value to the value shown in the table.

Categories and values are illustrative. Other categories and values may be more appropriate.

## 5. Performance Measure Estimation

Performance measure estimation is accomplished mostly within the travel demand model environment. This section focuses on the use of HCM procedures to estimate the roadway-related performance, plus two performance measures not typically produced by travel demand models: queuing and reliability. The discussion is split between the estimation of auto-related performance measures and multimodal performance measures (truck, transit, bicycle, and pedestrian).

### Auto-Related Performance Measures

#### *Demand-to-Capacity Ratio*

The demand-to-capacity ratio for each link is typically output by the travel demand model, based on the analyst's input capacity.

#### *Average Travel Speed and Average Travel Time*

The mean vehicle speed for through trips on a link is computed by the travel demand model during a traffic assignment process using either a speed-flow equation or a more-sophisticated approach that combines link delay with an estimate of mode delay.

**Demand Models That Compute Mode Delay.** If mode delay is used by the demand model, the following equation is used to compute average link speed, including mode delay.

$$S = \frac{L}{R + \frac{D}{3,600}} \quad \text{Equation 200}$$

where

- $S$  = mean link speed (mph),
- $L$  = link length (mi),
- $R$  = link travel time (h), and
- $D$  = mode delay for link (s).

The mode delay  $D$  is computed only for the traffic signal or STOP- or YIELD-controlled intersection at the end of the link (all other intersection related delays that occur in the middle of the link are incorporated in the link travel time calculation). The mode delay procedures described in Section L5 (signalized intersections), M5 (STOP-controlled intersections), or N4 (roundabouts) can be used. The calculation requires information on all of the intersection approaches at the mode so that the mean approach delay for each link feeding the intersection can be computed.

**Demand Models that Do Not Compute Mode Delay.** If the available travel demand model software package is unable to compute mode delay, the delay can be approximated by using the mode approach capacity rather than the link capacity in the computation of travel time  $T$ . In this situation, the mode delay is set to zero in Equation 200.

When a model does not model mode delay separately, it is necessary to include the intersection control delay with zero volume in the link's estimated free-flow speed. This diverges from the HCM practice of excluding intersection control delay from the free-flow speed for urban streets.

The following equation, commonly called the BPR or Bureau of Public Roads equation (Cambridge Systematics 2010), can be used to quickly estimate approximate link travel times.

$$T = T_0(1 + Ax^B) \quad \text{Equation 201}$$

where

- $T$  = link travel time (h),
- $T_0$  = link travel time at low near-zero volumes (h),
- $A$  = ratio of speed at capacity to free-flow speed, minus one (standard value = 0.15),
- $B$  = parameter that affects the rate at which speed drops (standard value = 4.0), and
- $x$  = the link demand-to-capacity ratio (unitless).

The calibration parameter  $A$  is selected so that the travel time equation will predict the mean speed of traffic when demand is equal to capacity. Substituting  $x = 1.00$  in the travel time equation and solving for  $A$  yields:

$$A = \frac{S_f}{S_c} - 1 \quad \text{Equation 202}$$

where

- $A$  = BPR speed at capacity calibration parameter,
- $S_c$  = mean speed at capacity (mph), and
- $S_f$  = mean free-flow speed (mph).

The calibration parameter  $B$  is selected to predict the approximate delay when demand exceeds capacity for a target range of demand-to-capacity ratios (generally in the range of 1.7 to 1.9).

The BPR curve (Equation 201) estimates the proportional increase in travel time at a given demand-to-capacity ratio. As speed and travel time are inversely related, a given proportional increase in travel time produces an identical proportional decrease in speed (i.e., doubling the travel time from free-flow conditions implies halving the speed). Therefore, Equation 201 is modified as shown in Equation 203 to work with free-flow speed as an input. Equation 203 is entered with the free-flow speed  $S_0$  (in mph) and the  $A$  and  $B$  parameters defined previously, and the link speed  $S$  (in mph) is computed.

$$S = S_0 / (1 + Ax^B) \tag{Equation 203}$$

Exhibit 129 shows recommended capacities, speeds at capacity, and values of the  $A$  and  $B$  parameters that were selected to reproduce the travel times at capacity predicted by the HCM’s analysis procedures.

It is important to note that there are many other speed–flow functions besides the BPR curve that can be and are used in demand modeling to predict the impacts of changes in demand on traffic speeds. These other functions may have properties superior to that of the BPR for the planner’s needs. Presentation, discussion, and demonstration of these other potential speed–flow functions are beyond the scope of this Guide.

### Vehicle-Hours and Person-Hours of Delay

Vehicle-hours and person-hours of delay are typically output by the travel demand model using thresholds specified by the analyst. Vehicle-hours and person-hours of travel time may be compared to an agency specified minimum speed goal for each link. The speed goal may be the link free-flow speed, or some other value.

### Level of Service

The HCM provides LOS measures for road segments, freeway segments, and intersections. LOS measures are also provided for freeway facilities and urban street facilities, but they are

**Exhibit 129. Recommended speed–flow equation parameters.**

Facility Type	Area Type	Free-Flow Speed (mph)	Capacity (veh/ln)	HCM Base Speed at Capacity (mph)	BPR A Parameter	BPR B Parameter
Freeway	Downtown*	55	1,800	50.0	0.10	7
	Urban	60	1,800	51.1	0.17	7
	Suburban	65	1,900	52.2	0.24	7
	Rural	70	1,900	53.3	0.31	7
Principal Highway	Rural Multilane	55	1,700	46.7	0.18	8
	Rural Two-lane	55	1,300	42.5	0.29	8
Minor Highway	Rural Multilane	45	1,500	42.2	0.07	9
	Rural Two-lane	45	1,300	32.5	0.38	9
Arterial	Downtown	25	700	6.7	2.71	3
	Urban	35	700	11.0	2.19	2
	Suburban	45	600	11.4	2.95	2
Collector	Downtown	25	600	6.7	2.71	3
	Urban	30	600	10.4	1.89	3
	Suburban	35	600	11.0	2.19	3

Note: \*The speeds and capacities shown here for downtown freeways may not be appropriate for more modern central business district and downtown areas.



**Exhibit 130. Illustrative system LOS report—typical weekday peak period.**

Area Type	Facility Type	Mode	LOS A-C	LOS D	LOS E	LOS F	Total
Urban	Freeways	Auto	7%	24%	38%	31%	100%
		Truck	4%	20%	38%	38%	100%
	Nonfreeway	Auto	16%	34%	34%	16%	100%
		Truck	5%	22%	38%	34%	99%
		Transit	10%	29%	38%	24%	101%
		Bicycle	12%	31%	37%	21%	101%
Pedestrian	31%	38%	24%	7%	100%		

Note: Values and categories are illustrative. Other area types, facility types, and modes may be appropriate.

applicable to only those individual facility types and begin to lose their meaning (masking out problem spots within the facility) when applied to facilities more than 10 miles in length.

Aggregate performance measures, such as vehicle-miles or person-miles traveled (VMT or PMT), vehicle-hours or person-hours traveled (VHT or PHT), and vehicle-hours or person-hours of delay (VHD or PHD) are generally the best basis for comparing future system performance to existing conditions or to future investment alternatives. However, it is often difficult to convey the significance or meaning of numerical results to the general public or decisionmakers.

Analysts may use A–F levels of service to try to convey the degree of acceptability of the performance results; however, one should use care when simplifying numerical results to a few letter grades. Rather than reporting a single letter grade for the entire system or mode of travel, area-wide or system-wide LOS reports should report the distribution of the segment and intersection LOS results, weighted by the VHT or PHT experiencing each specific segment and intersection LOS.

The link LOS is computed from the travel demand model’s link output by facility type and intersection control type. Service volume tables may be used to estimate link LOS.

The analyst may then choose to report the percentage of daily VHT experiencing each LOS by mode within the system. Further value can be gained by breaking down the road system results by facility type and area type. Exhibit 130 shows an illustrative system LOS report. Exhibit 131 shows how the system report for non-freeway facilities might be displayed in a dashboard format.

Note that at this point, the focus has been on results for a single average weekday with fair weather and no incidents, such as is typically produced by a travel demand model analysis. The reliability of that result under varying incident and weather conditions over the course of the year is addressed by post-processing the model’s single-day results, as described below.

**Exhibit 131. Illustrative system LOS dashboard—typical weekday peak period.**

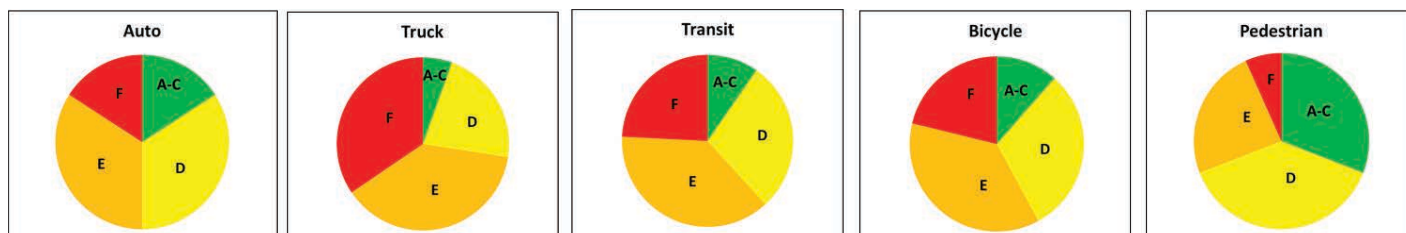

Note: Values and categories are illustrative. Other formats and modes may be appropriate.

### *Density*

Density can be computed for each roadway link by dividing the demand model's predicted directional volume in vehicles per hour per through lane by the demand model's predicted average link speed in miles per hour. The result is average number of vehicles per mile per through lane per hour.

### *Queuing*

Total system vehicle-hours in queue can be estimated. First, the predicted demand for a link is multiplied by the link's average travel time to obtain VHT. If the predicted link directional  $v/c$  ratio is greater than 1.00, or the average link speed is estimated to be below the speed at capacity, then the link is assumed to be in queue and the link's VHT is added to the tally of system vehicle-hours in queue (VHQ). Note that the queue may exceed the link's length. Demand models do not typically propagate queues upstream of the bottleneck link.

If intersection delay is not included in the estimate of average link travel times and speeds, then the intersection delay for the approach specific to the link is multiplied by the approach volume on the link and added to the estimated VHQ for the link.

### *Travel Time Reliability*

The travel time reliability for the freeways in the study area can be estimated using the procedures described in Section H7. These procedures produce the 95th percentile highest travel time index (TTI) and the percent of trips under 45 miles per hour for each freeway link. The procedure is illustrated in Case Study 3, Long-Range Transportation Plan Analysis (Section V).

## **Truck LOS**

Truck level of service can be estimated using the procedures described in Section P.

## **Transit, Bicycle, and Pedestrian LOS**

The level of service for bus transit, bicycles, and pedestrians can be estimated using the procedures described in Section O.

## **6. References**

- Cambridge Systematics, Inc. *Travel Model Validation and Reasonableness Checking Manual*, 2nd ed. Report FHWA-HEP-10-042. Federal Highway Administration, Washington, D.C., Sept. 24, 2010.
- Florida Department of Transportation. *2013 Florida Quality/Level of Service Handbook*. Systems Planning Office, Tallahassee, 2013.
- Highway Capacity Manual: A Guide to Multimodal Mobility Analysis*. 6th ed. Transportation Research Board, Washington, D.C., 2016.

# S. Roadway System Monitoring

2014 Roadway Performance Summary

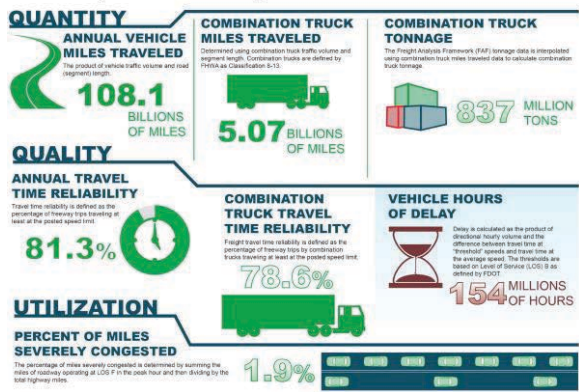

Source: Florida DOT (2015).

## 1. Overview

Transportation planners monitor the performance of the freeways and streets that make up a regional transportation system in order to identify problem spots and to assess the impacts of previous investments in transportation operations and capacity improvements. The performance of the system and its components are measured using recently available archived data on roadway travel times. The value of this monitoring process can be significantly enhanced through the use of various HCM relationships to identify and diagnose the causes of travel time reliability and capacity problems.

## 2. Travel Time Datasets

The methods described in this section assume that an agency has access to archived average travel times by road segment by time of day, similar to the National Performance Management Research Data Set (NPMRDS) (FHWA 2015). In the NPMRDS, each travel time observation is the average travel time for all vehicles on a traffic message channel (TMC) segment over a minute period. TMC segments are generally defined between driver navigation decision points on the network (e.g., between ramp gore points on a freeway or between intersections on an urban street) (ITS America 2010).

## 3. Identification of Problem Spots Through the Travel Time Index

The ratio of the actual travel time to the free-flow travel time, the travel time index (TTI), is a useful indicator of congestion problem spots (and times of day when congestion is present) on the roadway network.

### Estimation of Free-Flow Travel Time

The free-flow travel time is obtained from the archives by finding the 95th percentile travel time in the archives for the selected TMC segment.

Alternatively, the free-flow travel time may be estimated from the posted speed limit (with an analyst-selected adjustment, such as 5 mph, if appropriate) for the TMC segment. The analyst may choose to apply an adjustment to the posted speed limit to reflect local compliance with

the speed limit. The TMC segment length divided by the adjusted posted speed limit gives the free-flow travel time.

$$TT_{FF} = TT_{95} \text{ or } \frac{60 \times L}{PSL + UserAdj} \quad \text{Equation 204}$$

where

$TT_{FF}$  = free-flow travel time (min),

$TT_{95}$  = 95th percentile highest observed travel time (min),

$L$  = TMC segment length (mi),

$PSL$  = posted speed limit (mph), and

$UserAdj$  = user adjustment (mph) to account for local differences between the posted speed limit and the free-flow speed, and effects of intersection controls (if any) on maximum travel speeds under free-flow conditions.

### Computation of TTI

The TTI for a TMC segment is the ratio of the observed travel time to the free-flow travel time.

$$TTI = \frac{TT}{TT_{FF}} \quad \text{Equation 205}$$

where

$TTI$  = travel time index (unitless),

$TT$  = observed travel time (min), and

$TT_{FF}$  = free-flow travel time (min).

The TTI for a specific percentile condition (such as the 95th highest hour of the year) is computed using the travel time for the specific percentile condition. Thus, if the 95th percentile highest TTI is desired, the 95th percentile travel time is used in the computation.

### Identification of Congestion Problems

The identification of congestion problems consists of determining whether the TTI falls above a limit indicative of demands greater than capacity. It is possible to apply the planning methods described in the earlier chapters to identify the values of TTI when demand is likely to exceed capacity. This limit varies by facility type.

A table of free-flow speeds and speeds at capacity, such as illustrated in Exhibit 129 in Section R5, can be constructed based on assumed default free-flow speeds by functional class, facility type, and area type. The TTI threshold above which congestion (defined as demand greater than capacity) is present is then computed by dividing the speed at capacity into the free-flow speed. Exhibit 132 shows an example of such a table that can be used for congestion monitoring purposes.

From this table one can construct some general rules for interpreting TTIs. For uninterrupted-flow segments (freeways, rural multilane highways, and rural two-lane highways):

- If the observed TTI is 1.40 or greater, there is a high probability that the demand for the segment exceeds its capacity and the segment is congested.
- If the TTI is 1.05 or less, there is a high probability that the demand is less than capacity and the segment is uncongested.

**Exhibit 132. Illustrative TTI thresholds for monitoring congestion.**

Facility Type	Area Type	Free-Flow Speed (mph)	Capacity (veh/h/ln)	HCM Base Speed at Capacity (mph)	TTI at Capacity
Freeway	Downtown	55	1,800	50.0	1.10
	Urban	60	1,800	51.1	1.17
	Suburban	65	1,900	52.2	1.24
	Rural	70	1,900	53.3	1.31
Principal Highway	Rural Multilane	55	1,700	46.7	1.18
	Rural Two-lane	55	1,300	42.5	1.29
Minor Highway	Rural Multilane	45	1,500	42.2	1.07
	Rural Two-lane	45	1,300	32.5	1.38
Arterial	Downtown	25	700	6.7	3.71
	Urban	35	700	11.0	3.19
	Suburban	45	600	11.4	3.95
Collector	Downtown	25	600	6.7	3.71
	Urban	30	600	10.4	2.89
	Suburban	35	600	11.0	3.19

Note: Values in this table are illustrative and may not be applicable to a specific jurisdiction.

- If the TTI falls between 1.05 and 1.40, then it is uncertain whether the link is over capacity or not. Further information on the facility’s speed at capacity is needed to make a determination.

For interrupted-flow streets (i.e., streets with traffic signals, all-way STOP-controlled intersections, and roundabouts), a TTI of 1.30 may be indicative of intersection delays rather than any controlled intersection exceeding its capacity. Therefore, in the case of interrupted-flow segments:

- If the TTI is 4.00 or greater, there is a high probability that the demand for the segment exceeds its capacity and the segment is congested.
- If the TTI is 2.50 or less, there is a high probability that the demand is less than capacity and the segment is uncongested.
- If the TTI falls between 2.50 and 4.00, then it is uncertain whether the link is over capacity or not. Further information on the facility speed at capacity is needed to make a determination.

#### 4. Identification of Multimodal Problem Spots

Motor vehicle travel times are not a suitable indicator of bicycle and pedestrian problem spots. Motor vehicle volumes and speeds must be monitored in the context of the physical design of the bicycle and pedestrian travel ways to identify non-motorized-vehicle problem spots.

For transit, the motor vehicle TTI can be used as an indicator of likely transit problem spots, in the absence of exclusive lanes for transit.

For trucks, both the motor vehicle (auto plus truck) TTI and the truck specific TTI are inputs to the calculation of truck LOS (see Section P).

#### 5. Diagnosis of Causes of Mobility Problems

Once auto, truck, transit, bicycle, or pedestrian mobility problems are identified, the causes of the problems can be diagnosed through the planning application of the HCM as described in Part 2 of this Guide. Diagnosis will generally require some additional information beyond the travel times, such as volumes, geometry, and signal controls.

## 6. References

- Federal Highway Administration. *National Performance Management Research Data Set: Technical Frequently Asked Questions*. [http://www.ops.fhwa.dot.gov/freight/freight\\_analysis/perform\\_meas/vpds/npmrdsfaqs.htm](http://www.ops.fhwa.dot.gov/freight/freight_analysis/perform_meas/vpds/npmrdsfaqs.htm). Accessed April 11, 2015.
- Florida Department of Transportation. *Florida Multimodal Mobility Performance Measures Source Book*. Transportation Statistics Office, Tallahassee, 2015.
- ITS America, North American Traffic Working Group. *Traffic Information Benchmarking Guidelines*. Version 1.0. Washington, D.C., April 22, 2010.



## PART 4

# Case Studies

This part presents three case studies illustrating the application of the HCM to typical planning and preliminary engineering studies.

### Case Study 1: Freeway Master Plan

- Overview
- Example 1: focusing the study—screening for service volume problems
- Example 2: forecasting v/c hot spots
- Example 3: estimating speed and travel time
- Example 4: predicting unacceptable motorized vehicle LOS hot spots
- Example 5: estimating queues
- Example 6: predicting reliability problems
- Example 7: comparison of overcongested alternatives

### Case Study 2: Arterial BRT Analysis

- Overview
- Example 1: preliminary screening with service volume tables
- Example 2: computing critical intersection v/c ratios
- Example 3: calculation of intersection v/c ratio for permitted left turns
- Example 4: estimating auto and BRT speeds
- Example 5: predicting queue hot spots
- Example 6: pedestrian, bicycle, and transit LOS

### Case Study 3: Long-Range Transportation Plan Analysis

- Overview
- Example 1: estimating free-flow speeds and capacities for model input
- Example 2: HCM-based volume–delay functions for model input
- Example 3: Predicting density, queues, and delay
- Example 4: Predicting reliability



## T. Case Study 1: Freeway Master Plan

### 1. Overview

The case study site is the 70-mile-long stretch of U.S. 101 within San Luis Obispo County along the central California coast (Exhibit 133). Most of U.S. 101 within the county is a freeway, but there are also sections of multilane highway where access to the highway is provided by unsignalized intersections instead of by interchanges. A screening method is used to identify focus sections for more detailed analysis, as HCM freeway and highway facility analyses should be limited in length to approximately 15 miles (the distance that can be traveled in about 15 minutes).



### Terminology

This case study adopts the following terminology to carry the case study from the very high-level screening analysis to the more detailed HCM segment analysis:

- *Supersection*: Subdivisions of U.S. 101 with consistent broad characteristics (e.g., freeway versus highway, urban versus rural) extending for a number of miles.
- *Section*: Subdivisions of a supersection for more detailed planning application analysis.
- *Segments*: HCM analysis segments (e.g., basic freeway, basic multilane highway, weaving, merge, diverge); each section consists of multiple segments.

### Planning Objective

The agency's planning objective is to develop a Corridor Mobility Master Plan to identify current and future mobility problems in the corridor, and to establish capital project priorities along the corridor. The corridor plan study area includes freeway interchanges, adjacent frontage roads, and access points for non-motorized transportation.

### Background

U.S. 101 is a four-lane freeway throughout the region, with the exceptions of a six-lane segment with a 7% grade over the 1,522-foot-high Cuesta Grade, just north of the City of San Luis Obispo (California Department of Transportation 2002), and several rural multilane highway segments where unsignalized intersections rather than interchanges provide access to the highway. The majority of the freeway is located in rural areas; however, it passes through five urban areas within the county (Paso Robles, Atascadero, San Luis Obispo, Pismo Beach, and Arroyo Grande).

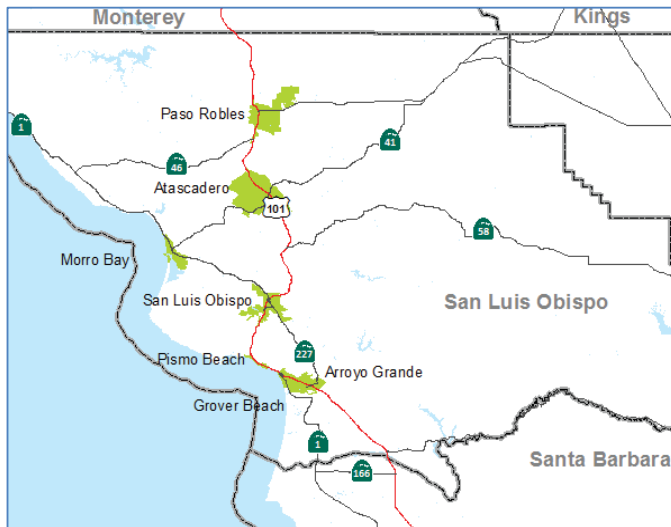

**Exhibit 133. Case study 1: study area.**

U.S. 101 carries between 20,000 and 74,000 AADT, depending on location. Truck traffic accounts for 8% to 10% of AADT. Trucks with five or more axles account for 50% to 55% of the observed truck volumes on the roadway. Recurring congestion occurs on short stretches that operate at LOS E or worse during the afternoon peak hour between San Luis Obispo and Pismo Beach.

### Example Problems Worked in this Case Study

The planning problems illustrated in this case study focus on the identification of future auto mobility problem spots. The specific worked examples are:

- Example 1: Focusing the Study—Screening for Service Volume Problems
- Example 2: Forecasting v/c Hot Spots
- Example 3: Estimating Speed and Travel Time
- Example 4: Predicting Unacceptable Motorized Vehicle LOS Hot Spots
- Example 5: Estimating Queues
- Example 6: Predicting Reliability Problems
- Example 7: Comparison of Overcongested Alternatives

These planning problems illustrate:

- The development, selection, and application of defaults for use in facility-level planning analyses of freeways and multilane highways;
- The identification of capacity bottlenecks and the prediction of queues in the study corridor;
- The computation of reliability for the freeway; and
- A volume-to-capacity ratio approach for comparing the performance of two alternatives, neither of which is able to completely eliminate congestion.

## 2. Example 1: Focusing the Study—Screening for Service Volume Problems

### Approach

The 70-mile facility will be split into supersections based on the facility's general characteristics (e.g., freeway versus highway, urban versus rural). As described in Section H4 of the Guide for freeways and Section I4 for multilane highways, service volume tables will be used to evaluate each supersection.

**Exhibit 134. Case study 1:  
flowchart for example 1.**

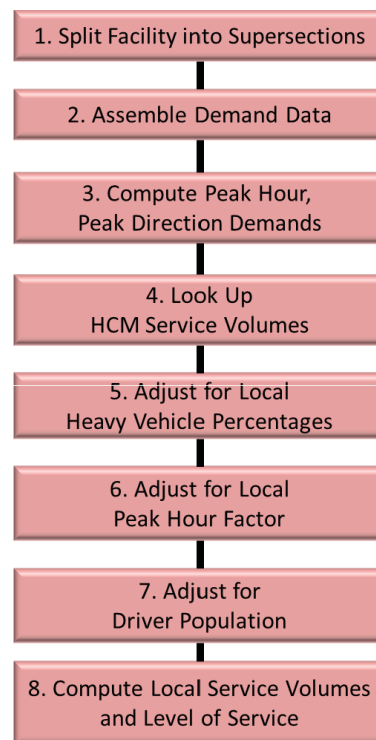

In this case, it will turn out that the traffic flow and geometric characteristics of the supersections generally correspond well with the defaults assumed in the construction of the HCM's generalized daily service volume tables in HCM Chapter 12, Basic Freeway and Multilane Highway Segments (HCM Exhibits 12-39 through 12-42). To use these tables, one merely compares a supersection's AADT to the value in the table for the appropriate  $K$ - (ratio of peak to daily traffic) and  $D$ - (directional) factors.

However, this example problem will also illustrate how to adjust the HCM's values for unique local circumstances. Therefore, the HCM's daily service volumes will be converted to the equivalent peak hour, peak direction flow rates per lane for use in screening individual supersections.

A flowchart for the analysis is shown in Exhibit 134.

### Step 1: Split Facility into Supersections

The facility is split into supersections where the facility type (controlled-access freeway or multilane highway), the general development intensity of the area (urban or rural), and the general terrain (level, rolling, or mountainous) are fairly constant within the supersection. There is no length limit for a supersection.

The terrain type is determined as follows:

- If the supersection has short grades (under 1 mile) of 2% or less, it is considered as passing through "level" terrain.
- If the supersection has short grades such that heavy vehicles are significantly slowed, but are not at their crawl speed (generally grades under 1 mile in length and 4% or less), then it can be considered as passing through "rolling" terrain.
- Supersections with longer or steeper grades that cause heavy vehicles to operate at their crawl speeds are designated as "mountainous."

**Exhibit 135. Case study 1: freeway supersections for screening.**



This process results in the 70-mile facility being split into nine supersections (A–I), as illustrated in Exhibit 135.

**Step 2: Assemble Demand Data**

The minimum demand data required to use a freeway or multilane highway service volume table, as described in Guide Sections H4 and I4, respectively, are the bi-directional AADT and *K*- (ratio of peak hour to daily traffic) and *D*- (directional proportion) ratios. Additional data used to evaluate the suitability of a service volume table for a particular analysis and, if necessary, to adjust the table’s values are the percent heavy vehicles, peak hour factor (PHF), and a capacity adjustment for unfamiliar drivers.

The bi-directional AADT is assembled for each supersection using data from the state DOT’s traffic monitoring program. If the AADT varies significantly (i.e., more than 25%) within a supersection, the analyst should consider splitting the supersection and evaluating each of its parts separately.

*K*-factors are obtained from local data in this case, but if not available, default values of 0.09 (urban) and 0.10 (rural) could be used from Exhibit 19 (freeway service volume table) and Exhibit 30 (multilane highway service volume table). Similarly, *D*-factors are obtained from local data in this case, but these exhibits provide a default value of 0.60 for use when local data are not available.

Except for supersection A, where another study was recently conducted, percent heavy vehicles and peak hour factors are not immediately available. Default values of 5% heavy vehicles (urban freeways and multilane highways), 10% heavy vehicles (rural multilane highways), and 12% heavy vehicles (rural freeways) are obtained instead from Exhibit 21 (freeway required data) and

Exhibit 32 (multilane highway required data). Similarly, default PHFs of 0.95 (urban multilane highways), 0.94 (freeways), and 0.88 (rural multilane highways) are applied to the supersections lacking PHF data. Finally, a default capacity adjustment factor (CAF) for driver population (i.e., familiarity with the facility) of 1.00 is applied in urban areas and 0.85 in rural areas.

The demand and other input data for this example problem are shown in rows 1–13 of Exhibit 136.

**Exhibit 136. Case study 1: screening analysis results.**

Row	Supersection	A	B	C	D	E	F	G	H	I
<b>Input Data</b>										
1	Limits: From	County L	Arroyo G	Avila Bc	Los Osos	SLO Ct N	Atasc S	Templ	Paso S	Paso N
2	Limits: To	Arroyo G	Avila Bch	Los Osos	SLO Ct N	Atasca S	Templ	Paso S	Paso N	County L
3	Length (mi)	12.4	8.4	4.8	4.7	13.1	8.2	4.9	2.9	10.6
4	Through lanes, 2 directions	4	4	4	4	6	4	4	4	4
5	Facility type	Highway	Freeway	Freeway	Freeway	Highway	Freeway	Freeway	Freeway	Highway
6	Area type	Urban	Urban	Rural	Urban	Rural	Urban	Urban	Urban	Rural
7	Terrain type	Level	Level	Level	Level	Mountain	Level	Level	Level	Level
8	AADT (2-Dir)	57,600	63,500	70,100	55,800	44,500	58,700	58,800	32,400	19,500
9	K-factor	0.09	0.08	0.08	0.09	0.09	0.09	0.09	0.09	0.08
10	D-factor	0.52	0.60	0.57	0.55	0.61	0.51	0.58	0.51	0.57
11	% heavy vehicles	10%	5%	12%	5%	12%	5%	5%	5%	12%
12	PHF	0.90	0.95	0.88	0.95	0.88	0.95	0.95	0.95	0.88
13	CAF	1.00	1.00	0.85	1.00	0.85	1.00	1.00	1.00	0.85
<b>Demand</b>										
14	Peak direction, veh/h/ln	1,350	1,520	1,600	1,380	810	1,350	1,530	740	440
<b>Initial HCM Service Volumes</b>										
15	HCM LOS C	1,360	1,550	1,460	1,550	1,220	1,550	1,550	1,550	1,220
16	HCM LOS D	1,700	1,890	1,770	1,890	1,520	1,890	1,890	1,890	1,520
17	HCM LOS E	1,940	2,150	2,010	2,150	1,730	2,150	2,150	2,150	1,730
<b>Adjust for Heavy Vehicles</b>										
18	$f_{HV}$ , HCM	0.926	0.952	0.893	0.952	0.893	0.952	0.952	0.952	0.893
19	$E_T$ , local	2.00	2.00	2.00	2.00	5.00	2.00	2.00	2.00	2.00
20	$f_{HV}$ , local	0.909	0.952	0.893	0.952	0.676	0.952	0.952	0.952	0.893
21	Heavy vehicle adjustment	0.982	1.000	1.000	1.000	0.757	1.000	1.000	1.000	1.000
<b>Adjust for PHF</b>										
22	HCM default PHF	0.95	0.95	0.88	0.95	0.88	0.95	0.95	0.95	0.88
23	Actual PHF	0.90	0.95	0.88	0.95	0.88	0.95	0.95	0.95	0.88
24	PHF adjustment	0.947	1.000	1.000	1.000	1.000	1.000	1.000	1.000	1.000
<b>Adjust for CAF</b>										
25	HCM Default CAF	1.00	1.00	1.00	1.00	1.00	1.00	1.00	1.00	1.00
26	Actual CAF	1.00	1.00	0.85	1.00	0.85	1.00	1.00	1.00	0.85
27	CAF adjustment	1.050	1.000	0.850	1.000	0.850	1.000	1.000	1.000	0.850
<b>Cumulative HCM service volume adjustment</b>										
28	Cumulative HCM service volume adjustment	0.930	1.000	0.850	1.000	0.643	1.000	1.000	1.000	0.850
29	Local LOS A service volume	0	0	0	0	0	0	0	0	0
30	Local LOS C service volume	1,260	1,550	1,240	1,550	780	1,550	1,550	1,550	1,040
31	Local LOS D service volume	1,580	1,890	1,500	1,890	980	1,890	1,890	1,890	1,290
32	Local LOS E service volume	1,800	2,150	1,710	2,150	1,110	2,150	2,150	2,150	1,470
33	<b>LOS</b>	D	A-C	E	A-C	D	A-C	A-C	A-C	A-C

Notes: AADT = average annual daily traffic volume in both directions.

K-factor = proportion of daily traffic occurring in the peak hour of the day.

D-factor = proportion of traffic in the peak direction during the peak hour of the day.

CAF = capacity adjustment factor for unfamiliar driver population.

PHF = peak hour factor.

$E_T$  = passenger car equivalent of heavy vehicle traffic stream.

$f_{HV}$  = adjustment factor for presence of heavy vehicles in traffic stream.

### Step 3: Compute Peak Hour, Peak Direction Demands

Each supersection's bi-directional AADT is multiplied by the supersection's  $K$ - and  $D$ -factors. The result is the supersection's peak hour demand in the peak direction, shown in row 14 of Exhibit 136.

### Step 4: Look-Up HCM Service Volumes

The analyst obtains the HCM maximum directional hourly service volumes LOS C, D, and E from Exhibit 19 (freeways) and Exhibit 30 (multilane highways). The unadjusted values for level terrain are shown in rows 15, 16, and 17, respectively, of Exhibit 136. The service volumes will be adjusted as needed for rolling or mountainous terrain in the next step.

### Step 5: Adjust for Local Heavy Vehicle Percentages

The service volumes obtained in the previous step are adjusted for heavy vehicle percentage values that differ from those used to generate the service volume table (in this case, subsection A, which is a multilane highway). The heavy vehicle adjustment factor  $f_{HV}$  for multilane highways is calculated using Equation 38. For supersection A, the percent heavy vehicles is 10% (0.10), the terrain is level, and the passenger car equivalency of one heavy vehicle on a multilane highway, according to Exhibit 31, is 2.0:

$$f_{HV} = \frac{1}{1 + P_{HV} \times (E_{HV} - 1)} = \frac{1}{1 + 0.10 \times (2.0 - 1)} = 0.909$$

The  $f_{HV}$  value used to create the service volume table, which assumed 5% heavy vehicles, is 0.952. Therefore, the HCM service volumes for supersection A will be multiplied by  $0.909 / 0.952 = 0.955$  in a later step to account for the differing heavy vehicle percentage. Rows 18–21 of Exhibit 136 show the calculation results for all supersections.

### Step 6: Adjust for Local Peak Hour Factors

The ratio of the local PHF and the PHF value used by the service volume table is calculated and will be used in a later step as a local adjustment to the table's service volumes. For supersection A, the local PHF is 0.90, the table's PHF is 0.95 (from Exhibit 136), and the ratio of the two is  $0.90/0.95 = 0.947$ . Rows 22–24 of Exhibit 136 show the calculation results for all supersections.

### Step 7: Adjust for Driver Population

Similar to the two previous steps, the ratio of the local CAF to the CAF used by the service volume table is calculated and used later as a local adjustment to the table's service volumes. In this case, a local CAF of 0.85 was applied to the rural sections (assuming non-regular drivers on this major route connecting northern and southern California) and 1.00 in the urban sections (assuming a high proportion of the traffic consists of commuters during the peak hour), while the service volume tables make no adjustment for driver population (i.e., CAF = 1.00). In the rural sections, the ratio is calculated as  $0.85 / 1.00 = 0.850$ . Rows 25–27 of Exhibit 136 show the calculation results for all supersections.

### Step 8: Compute Local Service Volumes and LOS

This step multiplies the adjustment factors calculated by Steps 5–7 (Row 28 of Exhibit 136). It then applies the combined adjustment factor to the HCM service volumes to arrive at a local

service volume for each supersection (Rows 29–32). Finally, the demands from Step 3 are compared to the local service volumes to obtain LOS (Row 33 Exhibit 136).

For example, for supersection A, the local heavy vehicle adjustment 0.955 is multiplied by the local PHF adjustment of 0.947 and the local driver population adjustment of 1.000 to arrive at a combined adjustment of 0.904. The HCM service volumes of 1,360, 1,700, and 1,940 veh/h/ln for LOS C, D, and E, respectively, are multiplied by 0.904 and rounded down to the nearest 10 to obtain local service volumes of 1,220, 1,530, and 1,750 respectively. The peak hour, peak direction demand in this supersection is 1,350 veh/h/ln, which is greater than 1,220 but less than or equal to 1,530 and therefore falls into the LOS D range.

## Comments

This screening analysis finds that three supersections (A, C, and E) have an estimated LOS of D or E. Consequently, these supersections are recommended to be analyzed in greater detail. The remainder of this case study will focus on one of these supersections, C, a 4.8-mile stretch of rural freeway that operates at an estimated LOS E.

## 3. Example 2: Forecasting v/c Hot Spots

### Approach

In Example 1, the 70-mile U.S. 101 in San Luis Obispo County, California, was screened for potential deficiencies that should be the focus of a more detailed planning analysis. This screening found that the 4.8-mile supersection between Avila Beach Road and Los Osos Valley Road (Exhibit 137) operates at an estimated LOS E. The focus of Example 2, therefore, is to identify problem areas within this supersection using a volume-to-capacity hot spot analysis. This analysis focuses on the southbound direction of U.S.101 during the weekday p.m. peak hour, which the screening analysis found was the most critical.

This example follows the simplified HCM method described in Section H6 of the Guide to gather the required data for a capacity analysis, divide the supersection into sections based on where traffic demands or capacity change, compute each section's free-flow speed, and finally estimate capacity and the corresponding v/c ratio for each section.

### Step 1: Defining Freeway Sections

Supersection C is split into freeway sections following the guidance in Section H6 of the Guide. Freeway section boundaries are defined to occur at points where either freeway demand or capacity changes (in other words, at all ramp merges, diverges, lane adds, and lane drops). Significant grade changes (to greater than 2% grades) should also be considered for separate sections.

In this case, there are no lane drops or significant grade changes, so the supersection is divided into the seven sections shown in the upper half of Exhibit 138 on the basis of the location of on-ramps and off-ramps. The even-numbered sections are identified as “ramp” sections because they start with an on-ramp and end with an off-ramp and because no auxiliary lanes connect the ramps. The odd-numbered sections are identified as basic sections with no ramp merge or weave effects.

### Step 2: Determine Data Requirements

The input data needed to evaluate v/c hot spots are shown in the left column of Exhibit 138. The global inputs include information for free-flow speed, peak hour factor (PHF), percent heavy vehicles, and *K*-factor. Future conditions analyses might also require a global growth factor.

**Exhibit 137. Case study 1: map of supersection C.**

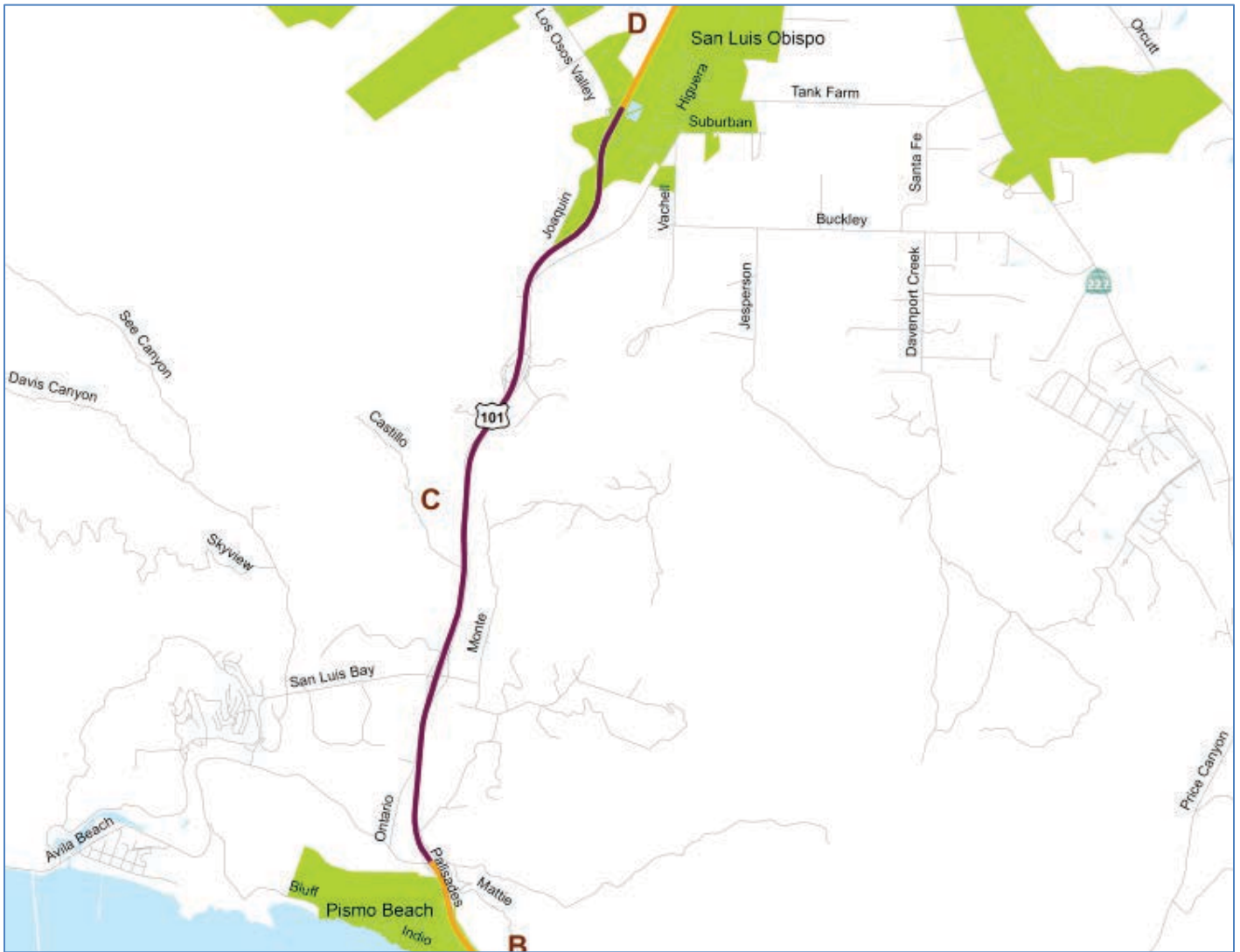

**Exhibit 138. Case study 1: segmentation and input data for supersection C (southbound).**

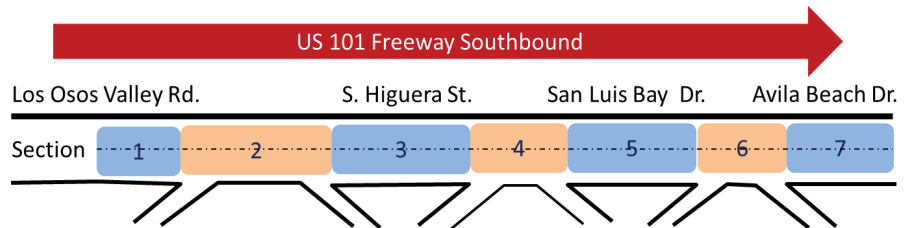

Section	C-1	C-2	C-3	C-4	C-5	C-6	C-7
<b>Section type</b>	Basic	Ramps	Basic	Ramps	Basic	Ramps	Basic
<b>Length (mi)</b>	0.05	1.65	0.24	1.51	0.37	0.81	0.18
<b>Lanes</b>	2	2	2	2	2	2	2
<b>Mainline AADT</b>	41,700						
<b>On-ramp AADT</b>		8,600		6,100		1,400	
<b>Off-ramp AADT</b>		500		4,600		1,400	
<b>K-factor</b>				0.08			
<b>% heavy vehicles</b>				6%			
<b>Free-flow speed</b>				65 mph			
<b>PHF</b>				0.92			

Section-specific inputs consist of segment type, segment length, number of directional lanes, and directional demand AADT. The analyst must provide daily demands for the first mainline freeway section and for all on- and off-ramps.

For this example, AADTs are obtained from the same traffic monitoring data source used for the screening analysis in Example 1. Because a smaller facility length is now being studied, it is also feasible to calculate a specific *K*-factor, heavy vehicle percentage, and peak hour factor, using data from a nearby permanent traffic counting station maintained by the state DOT. The free-flow speed is estimated on the basis of the speed limit. Because the freeway has a 65-mph speed limit for automobiles and a 55-mph speed limit for trucks and vehicles towing trailers, in the analyst’s judgment, a free-flow speed of 65 mph is most appropriate, rather than one greater than the automobile speed limit.

### Step 3: Estimate Section Capacities

The capacity of each individual section is calculated using Equation 16. This equation uses the free-flow speed and percent heavy vehicles as inputs. In addition, a capacity adjustment factor (CAF) can be applied to account for unfamiliar driver populations and the generally lower capacities of ramp merges and diverges. From Example 1, familiar driver populations were assumed for urban freeway sections (i.e., no adjustment was made for driver population). Based on the guidance in Section H6 of the Guide, a CAF of 0.95 is recommended for merges (i.e., on-ramps), with 0.97 recommended for diverges (i.e., off-ramps). As planning sections, rather than HCM segments, are being evaluated in this example, the smaller of the two CAFs (0.95) will control the capacity of a ramps section. Then, for freeway section C-2:

$$c_{C-2} = \frac{(2,200 + 10 \times (\min(70, S_{FFS}) - 50))}{1 + \%HV/100} \times CAF$$

$$c_{C-2} = \frac{(2,200 + 10 \times (\min(70, 65) - 50))}{1 + 6/100} \times 0.95$$

$$c_{C2} = 2,106 \text{ veh/h/ln}$$

The resulting capacity estimates for all sections are shown in Exhibit 139.

### Step 4: Convert AADTs to 15-Minute Flow Rates

In this step, AADTs are converted to peak 15-minute flow rates by applying the *K*-factor, the PHF, and (for future conditions analyses) a growth factor, as shown in Equation 17. For freeway section C-1 during the peak 15 minutes (assumed to be the second 15-minute interval within the peak hour), the calculation is as follows:

$$q_{C-1,2} = AADT_i \times k \times \left( \frac{1}{PHF} \right) \times f_{gf} = 41,700 \times 0.08 \times \left( \frac{1}{0.92} \right) \times 1.00 = 3,626 \text{ veh/h}$$

**Exhibit 139. Case study 1: peak hour section capacities for supersection C (southbound).**

Section	C-1	C-2	C-3	C-4	C-5	C-6	C-7
<b>Section type</b>	Basic	Ramps	Basic	Ramps	Basic	Ramps	Basic
<b>CAF</b>	1.00	0.95	1.00	0.95	1.00	0.95	1.00
<b>Per-lane capacity (veh/h/ln)</b>	2,217	2,106	2,217	2,106	2,217	2,106	2,217
<b>Number of directional lanes</b>	2	2	2	2	2	2	2
<b>Section capacity (veh/h)</b>	4,434	4,212	4,434	4,212	4,434	4,212	4,434



**Exhibit 140. Case study 1: peak flow rate calculations for sections in supersection C (southbound).**

Section	C-1	C-2	C-3	C-4	C-5	C-6	C-7
<b>Section type</b>	Basic	Ramps	Basic	Ramps	Basic	Ramps	Basic
<b>Mainline demand (veh/h)</b>	3,626						
<b>On-ramp demand (veh/h)</b>		748		530		122	
<b>Off-ramp demand (veh/h)</b>		43		400		122	

Equation 17 also assumes that the first and third 15-minute intervals within the peak hour will have average flow rates for the peak hour, while the last 15-minute interval will have a lower-than-average flow rate such that the sum of the demands of the four intervals will equal the total hourly demand. The demands for other intervals within the peak hour need to be calculated when performance measures such as duration of congestion or queue length are to be computed, as demand that cannot be served in one 15-minute interval must be carried over to the next interval. For the purposes of this example—determining hot spots where demand exceeds capacity—evaluating only the peak 15 minutes of the peak hour is sufficient. However, Step 8 will demonstrate the calculations for the full peak hour.

Exhibit 140 shows the results of the flow rate calculations for the mainline volume entering supersection C and for each of the ramps within the section, for the peak 15 minutes.

Before proceeding, these flow rates should be checked for any potential capacity constraints, following the Guide’s recommendations in Section H6. The mainline demand flow rate entering freeway section C-1, 3,626 veh/h, is less than the section capacity of 4,434 veh/h calculated in Step 3. The ramp flow rates are all less than the nominal capacity of 2,000 veh/h for a single-lane ramp stated in Section H6. Therefore, no constraints exist and these flow rates are carried forward to Step 5.

**Step 5: Assign Demands to Freeway Sections**

The demand in a given freeway section is computed as shown in Equation 18. Because unconstrained demands have been provided, the discharge rate is temporarily set to zero in Equation 18 for the purposes of creating initial demand estimates. Therefore, the demand entering a section is the demand served by the preceding section plus the section’s on-ramp demand.

The demand departing a section is the entering demand served minus the proportion of the off-ramp demand that can be served (i.e., can reach the off-ramp). If a section’s demand is less than or equal to the section’s capacity, then all of the off-ramp demand can be served. Otherwise, the off-ramp demand is reduced in proportion to the entering demand that is served.

The unserved demand in a section is carried over to the next time period (a step not required for evaluating v/c hot spots, but which will be demonstrated in Step 8).

For example, the demand entering section C-2 is the demand served by (i.e., departing) section C-1 (3,626 veh/h, from Exhibit 140) plus the on-ramp demand in section C-2 (748 veh/h), which totals 4,374 veh/h. Because section C-2’s capacity, as calculated in Step 5, is 4,212 veh/h, not all of this demand can be served, and the excess (162 veh/h) is carried over to the next time period. The demand served past the on-ramp is the section’s capacity 4,212 veh/h, and the proportion of the demand that is served is  $(4,212 / 4,374)$  or 0.963. Therefore, the off-ramp demand of 43 veh/h is reduced to  $(43 \times 0.963) = 41$  veh/h, as not all of the off-ramp demand can reach the ramp. The remaining demand,  $4,212 - 41 = 4,171$  veh/h is able to depart freeway section C-2 and become demand into section C-3.

**Exhibit 141. Case study 1: section demands for supersection C (southbound).**

Section	C-1	C-2	C-3	C-4	C-5	C-6	C-7
<b>Section type</b>	Basic	Ramps	Basic	Ramps	Basic	Ramps	Basic
<b>Mainline demand (veh/h)</b>	3,626						
<b>On-ramp demand (veh/h)</b>		748		530		122	
<b>Off-ramp demand (veh/h)</b>		43		400		122	
<b>Section entering demand (veh/h)</b>	3,626	<b>4,374</b>	4,171	<b>4,701</b>	3,854	3,976	3,854
<b>Section capacity (veh/h)</b>	4,434	4,212	4,434	4,212	4,434	4,212	4,434
<b>Proportion demand served</b>	1.000	0.963	1.000	0.896	1.000	1.000	1.000
<b>Off-ramp demand served (veh/h)</b>		41		358		122	
<b>Mainline exiting demand served (veh/h)</b>	3,626	4,171	4,171	3,854	3,854	3,854	3,854

Note: Values in **bold** indicate demands exceeding capacity, where downstream demand is constrained.

Exhibit 141 presents the calculations for all sections. Section entering demands shown in bold represent demands that exceed a section's capacity.

### Step 6: Compute d/c Ratios

In this step, the analyst calculates the demand-to-capacity (d/c) ratio for each section, which is simply the section entering demand divided by the section capacity. Exhibit 142 presents the calculation results.

### Step 7: Interpret d/c Results

In this step, potentially congested freeway sections are identified by examining which sections have d/c ratios greater than 1.00. The analysis indicates that sections C-2 and C-4 operate over capacity during the weekday p.m. peak hour. All other sections are expected to operate under capacity. Note, however, that if additional capacity was to be provided only in sections C-2 and C-4, other sections downstream of these sections might not be able to accommodate the additional demand served by sections C-2 and C-4. Diagnosing these potential hidden bottlenecks is discussed in Example 7.

### Step 8: Peak Hour Analysis

This step extends the analysis to the full p.m. peak hour. Although not needed to identify capacity problems, it is needed to calculate other performance measures that are demonstrated

**Exhibit 142. Case study 1: demand-to-capacity ratios for supersection C (southbound).**

Section	C-1	C-2	C-3	C-4	C-5	C-6	C-7
<b>Section type</b>	Basic	Ramps	Basic	Ramps	Basic	Ramps	Basic
<b>Section entering demand (veh/h)</b>	3,626	4,374	4,171	4,701	3,854	3,976	3,854
<b>Section capacity (veh/h)</b>	4,434	4,212	4,434	4,212	4,434	4,212	4,434
<b>Demand-to-capacity ratio</b>	0.82	1.04	0.94	1.12	0.87	0.94	0.87

**Exhibit 143. Case study 1: section demands for supersection C (southbound, time period 1).**

Section	C-1	C-2	C-3	C-4	C-5	C-6	C-7
<b>Section type</b>	Basic	Ramps	Basic	Ramps	Basic	Ramps	Basic
<b>Mainline demand (veh/h)</b>	3,336						
<b>On-ramp demand (veh/h)</b>		688		488		112	
<b>Off-ramp demand (veh/h)</b>		40		368		112	
<b>Section entering demand (veh/h)</b>	3,336	4,024	3,984	<b>4,472</b>	3,865	3,977	3,865
<b>Section capacity (veh/h)</b>	4,434	4,212	4,434	4,212	4,434	4,212	4,434
<b>Proportion demand served</b>	1.000	1.000	1.000	0.942	1.000	1.000	1.000
<b>Off-ramp demand served (veh/h)</b>		40		347		112	
<b>Mainline exiting demand served (veh/h)</b>	3,336	3,984	3,984	3,865	3,865	3,865	3,865
<b>Carryover demand to time period 2 (veh/h)</b>	0	0	0	260	0	0	0

Note: Values in **bold** indicate demands exceeding capacity, where downstream demand is constrained.

in subsequent examples. Steps 4–6 are repeated for each 15-minute interval within the peak hour, with any unserved demand in a section carried over into the next interval. Exhibit 143 through Exhibit 146 show the calculation results.

Note that the excess demand in freeway section C-4 cannot be cleared within the first hour of the analysis. A second hour of analysis should be performed using the same procedures (as demonstrated in Step 7) until no carryover demand remains. For simplicity's sake, however, this case study will show the results only for the first hour of analysis.

One potential way to present the facility results is to create a contour diagram similar to Exhibit 147 that shows the d/c ratio for each section for each time period, to visually detect potential bottleneck locations on the study facility.

**Exhibit 144. Case study 1: section demands for supersection C (southbound, time period 2).**

Section	C-1	C-2	C-3	C-4	C-5	C-6	C-7
<b>Section type</b>	Basic	Ramps	Basic	Ramps	Basic	Ramps	Basic
<b>Mainline demand (veh/h)</b>	3,626						
<b>Carryover demand from time period 1 (veh/h)</b>	0	0	0	260	0	0	0
<b>On-ramp demand (veh/h)</b>		748		530		122	
<b>Off-ramp demand (veh/h)</b>		43		400		122	
<b>Section entering demand (veh/h)</b>	3,626	<b>4,374</b>	4,171	<b>4,961</b>	3,872	3,994	3,872
<b>Section capacity (veh/h)</b>	4,434	4,212	4,434	4,212	4,434	4,212	4,434
<b>Proportion demand served</b>	1.000	0.963	1.000	0.849	1.000	1.000	1.000
<b>Off-ramp demand served (veh/h)</b>		41		340		122	
<b>Mainline exiting demand served (veh/h)</b>	3,626	4,171	4,171	3,872	3,872	3,872	3,872
<b>Carryover demand to time period 3 (veh/h)</b>	0	162	0	749	0	0	0

Note: Values in **bold** indicate demands exceeding capacity, where downstream demand is constrained.

**Exhibit 145. Case study 1: section demands for supersection C (southbound, time period 3).**

Section	C-1	C-2	C-3	C-4	C-5	C-6	C-7
<b>Section type</b>	Basic	Ramps	Basic	Ramps	Basic	Ramps	Basic
<b>Mainline demand (veh/h)</b>	3,336						
<b>Carryover demand from time period 2 (veh/h)</b>	0	162	0	749	0	0	0
<b>On-ramp demand (veh/h)</b>		688		488		112	
<b>Off-ramp demand (veh/h)</b>		40		368		112	
<b>Section entering demand (veh/h)</b>	3,336	4,186	4,146	<b>5,383</b>	3,924	4,036	3,924
<b>Section capacity (veh/h)</b>	4,434	4,212	4,434	4,212	4,434	4,212	4,434
<b>Proportion demand served</b>	1.000	1.000	1.000	0.782	1.000	1.000	1.000
<b>Off-ramp demand served (veh/h)</b>		40		288		112	
<b>Mainline exiting demand served (veh/h)</b>	3,336	4,146	4,146	3,924	3,924	3,924	3,924
<b>Carryover demand to time period 4 (veh/h)</b>	0	0	0	1,171	0	0	0

Note: Values in **bold** indicate demands exceeding capacity, where downstream demand is constrained.

## 4. Example 3: Estimating Speed and Travel Time

### Approach

In the previous examples, the freeway was screened for potentially deficient facility supersections (Example 1). The identified critical supersection (C) was then further evaluated for capacity hot spots during the weekday p.m. peak period (Example 2). In this example problem, speed and travel time will be estimated for all individual sections within supersection C.

Speeds will be estimated for each section for each 15-minute interval on the basis of delay rates, following the process described in Section H6 of the Guide. The estimated delay for a given

**Exhibit 146. Case study 1: section demands for supersection C (southbound, time period 4).**

Section	C-1	C-2	C-3	C-4	C-5	C-6	C-7
<b>Section type</b>	Basic	Ramps	Basic	Ramps	Basic	Ramps	Basic
<b>Mainline demand (veh/h)</b>	3,046						
<b>Carryover demand from time period 3 (veh/h)</b>	0	0	0	1,171	0	0	0
<b>On-ramp demand (veh/h)</b>		628		446		102	
<b>Off-ramp demand (veh/h)</b>		37		336		102	
<b>Section entering demand (veh/h)</b>	3,046	3,674	3,637	<b>5,254</b>	3,943	4,045	3,943
<b>Section capacity (veh/h)</b>	4,434	4,212	4,434	4,212	4,434	4,212	4,434
<b>Proportion demand served</b>	1.000	1.000	1.000	0.802	1.000	1.000	1.000
<b>Off-ramp demand served (veh/h)</b>		37		269		102	
<b>Mainline exiting demand served (veh/h)</b>	3,046	3,637	3,637	3,943	3,943	3,943	3,943
<b>Carryover demand to time period 5 (veh/h)</b>	0	0	0	1,042	0	0	0

Note: Values in **bold** indicate demands exceeding capacity, where downstream demand is constrained.

**Exhibit 147. Case study 1: d/c contour diagram for supersection C (southbound, p.m. peak hour).**

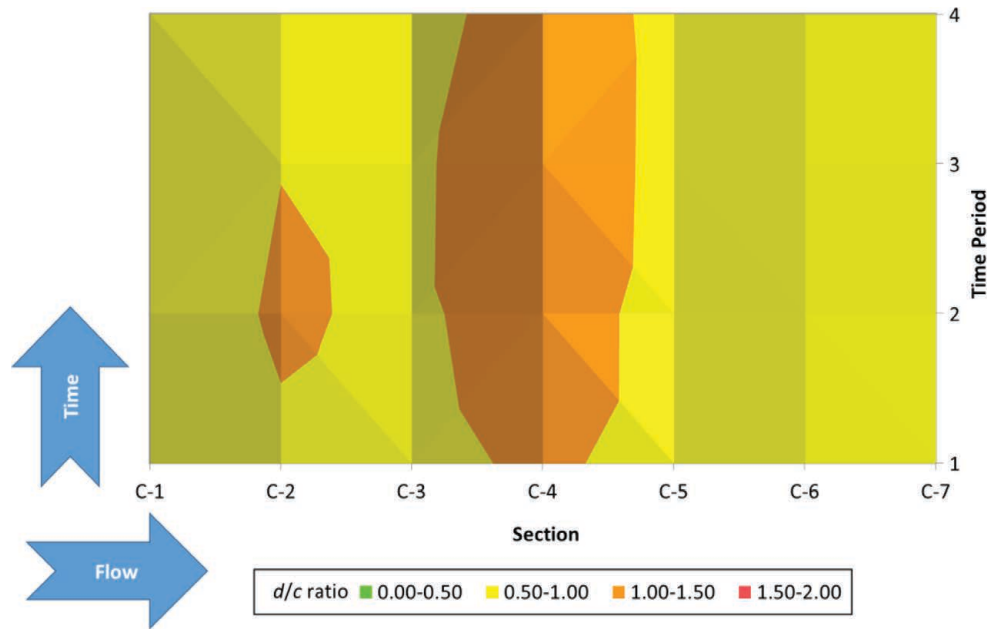

section will be added to the section’s travel time at free-flow speed to reflect congestion effects. Delay rates are computed separately for undersaturated ( $d/c \leq 1.00$ ) and oversaturated ( $d/c > 1.00$ ) conditions. Travel times are computed from the delay rates. Finally, speeds are computed using each section’s travel time and length.

**Step 1: Estimate Section Speeds**

Freeway section delay rates are estimated using Equation 20 (for  $d/c$  ratios  $\leq 1.05$ ) or Equation 21 (otherwise) from Section H6 of the Guide. Both equations require only the  $d/c$  ratio as an input.

For freeway section C-3 in time period 1, Exhibit 143 shows that the section demand is 3,984 veh/h, while the section capacity is 4,434 veh/h, which gives a  $d/c$  ratio of 0.899. As this ratio is less than 1, Equation 20 is used.

$$\Delta_{RU_{it}} = \begin{cases} 0 \frac{d_{i,t}}{c_i} < E \\ A \left( \frac{d_{i,t}}{c_i} \right)^3 + B \left( \frac{d_{i,t}}{c_i} \right)^2 + C \left( \frac{d_{i,t}}{c_i} \right) + D E \leq \frac{d_{i,t}}{c_i} \leq 1.00 \end{cases}$$

Values for the parameters A, B, C, D, and E are provided in Exhibit 25. For a freeway with a free-flow speed of 65 mph, these values are 92.45, -127.33, 56.34, -8.00, and 0.62, respectively. As the section’s  $d/c$  ratio is greater than 0.62, delay will occur in the section and the second part of the equation is applied as follows:

$$\Delta_{RU_{C-3}} = 92.45(0.899)^3 - 127.33(0.899)^2 + 56.34(0.899) - 8.00 = 6.9 \text{ s/mi}$$

As this freeway section is undersaturated, there is no additional oversaturated delay (i.e.,  $\Delta_{RO_{it}} = 0$ ). The average travel time for freeway section C-3 in time period 1 is then given by Equation 22:

$$T_{C-3,1} = \frac{3,600L_{C-3}}{FFS_{C-3}} + L_{C-3}(\Delta_{RU_{C-3,1}} + \overline{\Delta_{RO_{C-3,1}}}) = \frac{3,600 \times 0.24}{65} + 0.24(6.9 + 0) = 14.9 \text{ s}$$

This travel time can then be converted into a speed as follows:  $(3,600 \text{ s/h}) / (14.9 \text{ s}) \times (0.24 \text{ mi}) = 58.0 \text{ mph}$ .

For freeway section C-4 in time period 1, Exhibit 143 shows that the section demand is 4,472 veh/h, while the section capacity is 4,212 veh/h, which gives a d/c ratio of 1.062. As this ratio is greater than 1, both Equation 20 and Equation 21 are used. First, Equation 20 is applied with a d/c ratio of 1.00:

$$\Delta_{RU_{C-4,1}} = 92.45(1)^3 - 127.33(1)^2 + 56.34(1) - 8.00 = 13.5 \text{ s/mi}$$

Note that this value results for any oversaturated freeway section with a free-flow speed of 65 mph. Next, Equation 21 is applied to determine the additional oversaturated delay:

$$\overline{\Delta_{RO_{C-4,1}}} = \frac{900}{2 \times 1.51}(1.062 - 1) = 18.5 \text{ s/mi}$$

Equation 22 gives the average travel time for the section:

$$T_{C-4,1} = \frac{3,600L_{C-4}}{FFS_{C-4}} + L_{C-4}(\Delta_{RU_{C-4,1}} + \overline{\Delta_{RO_{C-4,1}}}) = \frac{3,600 \times 1.51}{65} + 1.51(13.5 + 18.5) = 131.9 \text{ s}$$

Finally, the average travel time is converted into a speed as follows:  $(3,600 \text{ s/h}) / (131.9 \text{ s}) \times (1.51 \text{ mi}) = 41.2 \text{ mph}$ . Exhibit 148 provides results for all sections and time periods.

**Exhibit 148. Case study 1: p.m. peak hour section speeds for supersection C (southbound).**

Section	C-1	C-2	C-3	C-4	C-5	C-6	C7
<b>Section type</b>	Basic	Ramps	Basic	Ramps	Basic	Ramps	Basic
<b>Length (mi)</b>	0.05	1.65	0.24	1.51	0.37	0.81	0.18
<b>Time Period 1</b>							
<b>Undersat. delay rate (s/mi)</b>	1.7	10.2	6.9	13.5	5.6	9.5	5.6
<b>Oversat. delay rate (s/mi)</b>	0	0	0	18.4	0	0	0
<b>Travel time (s)</b>	2.9	108.3	14.9	131.7	22.6	52.6	11.0
<b>Speed (mph)</b>	62.1	54.8	58.0	41.3	58.9	55.4	58.9
<b>Time Period 2</b>							
<b>Undersat. delay rate (s/mi)</b>	3.5	13.5	9.3	13.5	5.7	9.8	5.7
<b>Oversat. delay rate (s/mi)</b>	0	10.4	0	53.0	0	0	0
<b>Travel time (s)</b>	2.9	130.9	15.5	184.0	22.6	52.8	11.0
<b>Speed (mph)</b>	62.1	45.4	55.7	29.5	58.9	55.2	58.9
<b>Time Period 3</b>							
<b>Undersat. delay rate (s/mi)</b>	1.7	13.0	8.9	13.5	6.2	10.4	6.2
<b>Oversat. delay rate (s/mi)</b>	0	0	0	82.8	0	0	0
<b>Travel time (s)</b>	2.9	112.8	15.4	229.1	22.8	53.3	11.1
<b>Speed (mph)</b>	62.1	52.7	56.1	23.7	58.4	54.7	58.4
<b>Time Period 4</b>							
<b>Undersat. delay rate (s/mi)</b>	0.6	5.6	3.6	13.5	6.4	10.6	6.4
<b>Oversat. delay rate (s/mi)</b>	0	0	0	73.7	0	0	0
<b>Travel time (s)</b>	2.8	100.7	14.1	215.3	22.9	53.4	11.1
<b>Speed (mph)</b>	64.3	59.0	61.3	25.2	58.2	54.6	58.4

Note: undersat. = undersaturated, oversat. = oversaturated.

**Exhibit 149. Case study 1: speed contour diagram for supersection C (southbound, p.m. peak hour).**

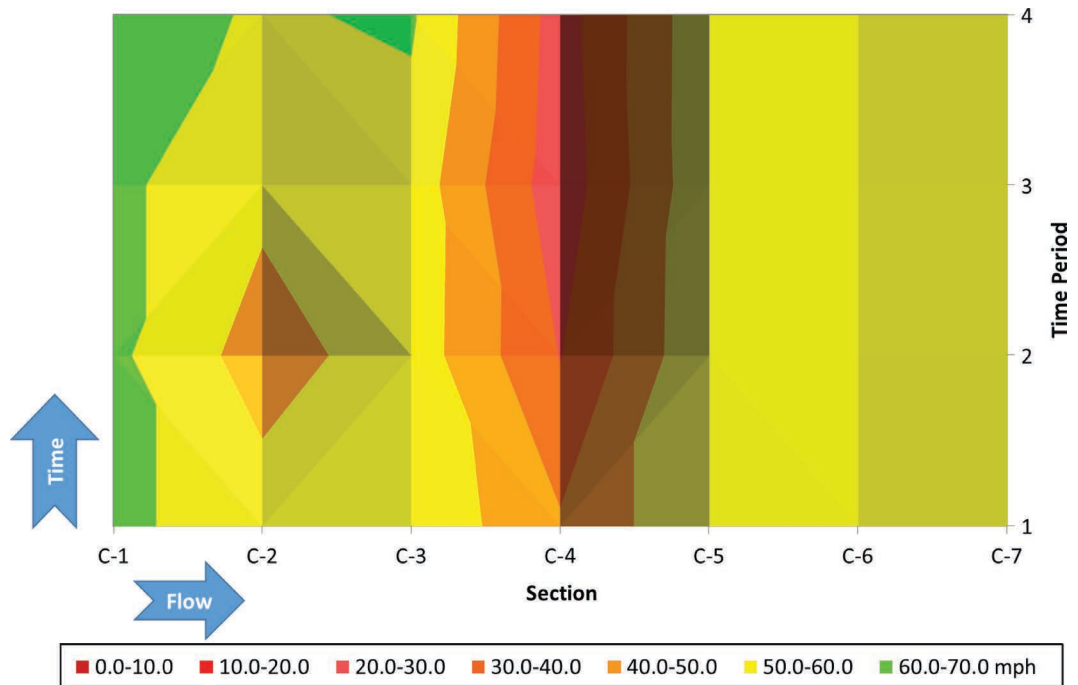

**Step 2: Interpreting Speed Results**

The computed average speeds can be used to generate a contour diagram similar to the one shown in Exhibit 149 for spotting a speed range that indicates section congestion. By the visual method, the analyst will be able to determine which sections experience low speeds, and for how long. Exhibit 149 indicates a bottleneck in freeway section C-4, as speeds are expected to drop to less than 30 mph during the analysis period. In addition, note that low speeds at the end of the hour indicate that queuing persists beyond the end of the peak hour in section C-4. This result suggests the need to continue the analysis for another hour to adequately capture the congestion occurring on the facility. For simplicity’s sake, however, this example only shows the first hour of analysis.

**5. Example 4: Predicting Unacceptable Motorized Vehicle LOS Hot Spots**

**Approach**

In the previous examples, the freeway was screened for potentially deficient facility supersections (Example 1). The identified critical supersection (C) was then further evaluated for capacity hot spots during the weekday p.m. peak period (Example 2). Next, speed and travel time were estimated for all individual sections within supersection C (Example 3). In this example, vehicular density and motorized vehicle LOS will be determined for supersection C, following the process described in Section H6 of the Guide.

**Step 1: Compute Density**

The density of vehicles in each section, in vehicles per mile, is computed by dividing the section’s demand served by its average speed, as given by Equation 27. For example, for freeway

section C-4 in time period 1, the demand served is 4,212 veh/h (Exhibit 143), the average speed is 41.3 mph (Exhibit 148), and the vehicular density is therefore

$$D_{C-4,1} = \frac{d_{C-4,1}}{S_{C-4,1}} = \frac{4,212}{41.3} = 102.0 \text{ veh/mi}$$

As the section has two lanes in the study direction, the density is 51.0 veh/mi/ln when expressed on a per-lane basis.

Because the HCM expresses density in units of passenger cars per mile per lane for the purpose of determining motorized vehicle LOS, Equation 28 is used to make the conversion from vehicles to passenger cars. The section's peak hour factor is the same as its parent supersection C, which was found in Example 2 (0.92). Also from Example 2, supersection C is level (i.e., the heavy vehicle equivalency factor is 2.0 from Exhibit 20) and the percentage of heavy vehicles is 6%. Then:

$$f_{HV} = \frac{1}{1 + P_{HV} \times (E_{HV} - 1)} = \frac{1}{1 + 0.06 \times (2.0 - 1)} = 0.943$$

$$D_{PC} = \frac{D}{PHF \times f_{HV}} = \frac{51.0}{0.92 \times 0.943} = 58.8 \text{ pc/mi/ln}$$

## Step 2: Determine LOS

The section's computed density is used to look-up the LOS by facility type (freeway or highway) and area type (urban or rural). As supersection C is a rural freeway, the right-hand column of Exhibit 26 is used. In the case of section C-4 during the first time period, the section's volume-to-capacity exceeds 1.00, so the LOS is automatically F regardless of the density. In the case of section C-2 during the third time period, the section's volume-to-capacity ratio is less than 1.00, but the density of 45.8 pc/mi/ln exceeds the LOS F threshold of 39 pc/mi/ln for rural freeways, so this section is assigned LOS F during this time period. Exhibit 150 summarizes the results for all sections and time periods.

## Step 3: Interpreting LOS Results

At this stage, an analyst would have all basic performance measures identified for all individual sections of supersection C. It is estimated that freeway sections C-2 and C-4 would experience congested conditions during the weekday p.m. peak hour, based on their LOS F results. The sections with worse LOS operations are typically indicated by high  $d/c$  ratios, low speeds, and high travel time delay, as illustrated in the previous examples. As was the case for  $d/c$  ratios and speeds, a contour diagram similar to Exhibit 151 can be developed to visually illustrate the extent and duration of poor LOS conditions.

The diagram indicates LOS problems in freeway sections C-2 and C-4. LOS F conditions in section C-2 are contained within the peak hour, but the LOS F conditions in section C-4 persist for the entire peak hour. In an actual study, it would be recommended that the analysis be extended earlier and later in the afternoon to better account for all of the congestion associated with the bottleneck in section C-4.

## 6. Example 5: Estimating Queues

### Approach

In the previous examples, the freeway was screened for potentially deficient facility supersections (Example 1). The identified critical supersection (C) was then further evaluated for capacity hot



**Exhibit 150. Case study 1: p.m. peak hour section densities and LOS for supersection C (southbound).**

Section	C-1	C-2	C-3	C-4	C-5	C-6	C-7
<b>Section type</b>	Basic	Ramps	Basic	Ramps	Basic	Ramps	Basic
<b>Number of lanes</b>	2	2	2	2	2	2	2
<b>Time Period 1</b>							
<b>Served demand (veh/h)</b>	3,336	4,024	3,984	4,212	3,865	3,977	3,865
<b>Speed (mph)</b>	62.1	54.8	58.0	41.3	58.9	55.4	58.9
<b>Density (veh/mi/ln)</b>	26.9	36.7	34.4	51.0	32.8	35.9	32.8
<b>Density (pc/mi/ln)</b>	31.0	42.3	39.6	58.8	37.8	41.3	37.8
<b>LOS</b>	D	E	E	F	E	E	E
<b>Time Period 2</b>							
<b>Served demand (veh/h)</b>	3,626	4,212	4,171	4,212	3,872	3,994	3,872
<b>Speed (mph)</b>	62.1	45.4	55.7	29.5	58.9	55.2	58.9
<b>Density (veh/mi/ln)</b>	29.2	46.4	37.4	71.3	32.8	36.2	32.9
<b>Density (pc/mi/ln)</b>	33.7	53.5	43.1	82.2	37.9	41.7	37.9
<b>LOS</b>	D	F	E	F	E	E	E
<b>Time Period 3</b>							
<b>Served demand (veh/h)</b>	3,336	4,186	4,146	4,212	3,924	4,036	3,924
<b>Speed (mph)</b>	62.1	52.7	56.1	23.7	58.4	54.7	58.4
<b>Density (veh/mi/ln)</b>	26.9	39.7	36.9	88.8	33.6	36.9	33.6
<b>Density (pc/mi/ln)</b>	31.0	45.8	42.6	102.3	38.7	42.5	38.7
<b>LOS</b>	D	F	E	F	E	E	E
<b>Time Period 4</b>							
<b>Served demand (veh/h)</b>	3,046	3,674	3,637	4,212	3,943	4,045	3,943
<b>Speed (mph)</b>	64.3	59.0	61.3	25.2	58.2	54.6	58.4
<b>Density (veh/mi/ln)</b>	23.7	31.1	29.7	83.4	33.9	37.0	33.8
<b>Density (pc/mi/ln)</b>	27.3	35.9	34.2	96.1	39.1	42.7	38.9
<b>LOS</b>	D	E	D	F	E	E	E

**Exhibit 151. Case study 1: LOS contour diagram for supersection C (southbound, p.m. peak hour).**

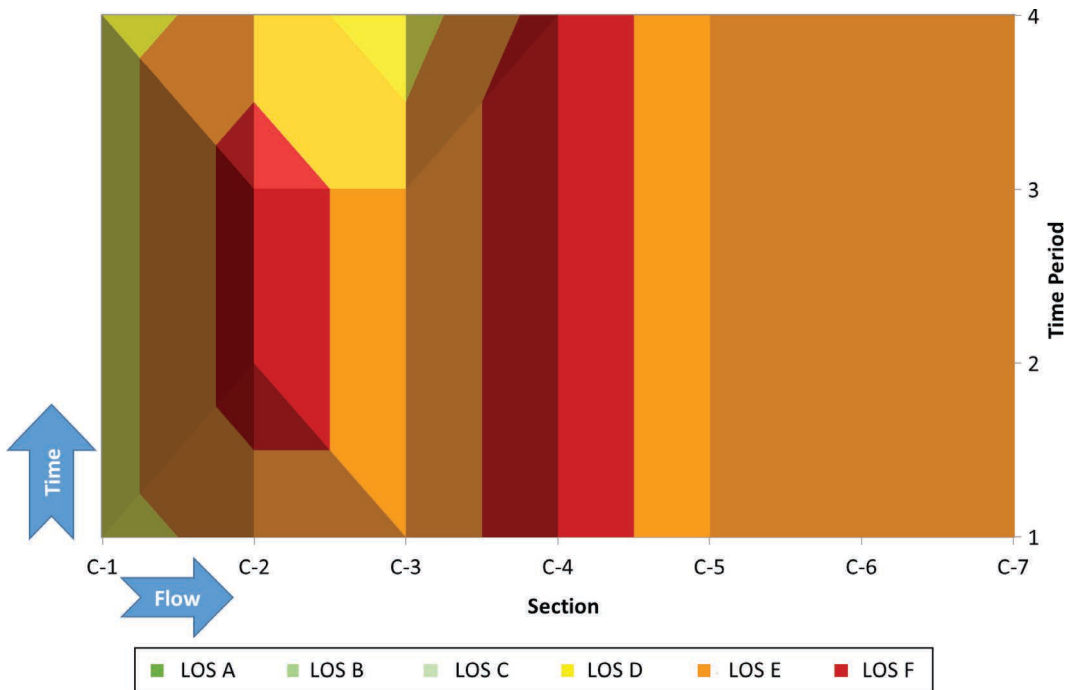

spots during the weekday p.m. peak period (Example 2). Next, speed and travel time were estimated for all individual sections within supersection C (Example 3). Most recently, vehicular density and motorized vehicle LOS were determined for supersection C (Example 4).

In this example, queue lengths will be estimated for individual freeway sections experiencing queuing during the weekday p.m. peak hour, following the approach described in Section H6 of the Guide. A queue typically occurs on sections when the demand is greater than the freeway section capacity. A section is considered to be 100% queued if the queue length (at the estimated queue density) exceeds the available lane-miles of storage in that section.

### Step 1: Queue Estimation

Equation 31 is used to estimate queuing. The freeway sections where demand exceeds capacity during at least one time period during the weekday p.m. peak hour were determined in Example 2 to be sections C-2 and C-4. All of the information needed to estimate queue length—demand, capacity, and density—have been determined in previous examples. For example, for section C-4 during the first time period, the demand is 4,472 veh/h while the capacity is 4,212 veh/h (Example 2), and the section density is 51.0 veh/mi/ln (Example 4). Then:

$$QL_{C-4,1} = \frac{\max(d_{C-4,1} - c_{C4}, 0)}{D_{C-4,1}} = \frac{\max(4,472 - 4,212, 0)}{51.0} = 51.0 \text{ mi}$$

As section C-4 has two lanes, the queue is 2.55 miles long. As the section is only 1.51 miles long, an additional 1.04 miles of queue is unserved, and the section is considered to be 100% in queue.

Exhibit 152 provides queuing results for all of supersection C during the weekday p.m. peak hour.

**Exhibit 152. Case study 1: p.m. peak hour queue lengths for supersection C (southbound).**

Section	C-1	C-2	C-3	C-4	C-5	C-6	C-7
<b>Section type</b>	Basic	Ramps	Basic	Ramps	Basic	Ramps	Basic
<b>Number of lanes</b>	2	2	2	2	2	2	2
<b>Section length (mi)</b>	0.05	1.65	0.24	1.51	0.37	0.81	0.18
<b>Capacity (veh/h)</b>	4,434	4,212	4,434	4,212	4,434	4,212	4,434
<b>Time Period 1</b>							
<b>Demand (veh/h)</b>	3,336	4,024	3,984	4,472	3,865	3,977	3,865
<b>Density (veh/mi/ln)</b>	26.9	36.7	34.4	51.0	32.8	35.9	32.8
<b>Queue length (mi)</b>				2.55			
<b>Percent queue</b>				100%			
<b>Time Period 2</b>							
<b>Demand (veh/h)</b>	3,626	4,374	4,171	4,961	3,872	3,994	3,872
<b>Density (veh/mi/ln)</b>	29.2	46.4	37.4	71.3	32.8	36.2	32.9
<b>Queue length (mi)</b>		1.74		5.26			
<b>Percent queue</b>		100%		100%			
<b>Time Period 3</b>							
<b>Demand (veh/h)</b>	3,336	4,186	4,146	5,383	3,924	4,036	3,924
<b>Density (veh/mi/ln)</b>	26.9	39.7	36.9	88.8	33.6	36.9	33.6
<b>Queue length (mi)</b>				6.60			
<b>Percent queue</b>				100%			
<b>Time Period 4</b>							
<b>Demand (veh/h)</b>	3,046	3,674	3,637	5,254	3,943	4,045	3,943
<b>Density (veh/mi/ln)</b>	23.7	31.1	29.7	83.4	33.9	37.0	33.8
<b>Queue length (mi)</b>				6.25			
<b>Percent queue</b>				100%			

## Step 2: Interpreting the Results

The planning-level freeway facility method does not contain a queue propagation algorithm, which explains why freeway sections C-2 and C-4 have queue lengths exceeding the section length. As such, the measure of “percent segment queued” is only meaningful up to 100%. The analyst is encouraged to perform a more detailed operational analysis for facilities with significant queuing impacts.

## 7. Example 6: Predicting Reliability Problems

### Approach

Previously, the freeway was screened for potentially deficient facility supersections (Example 1). The identified critical supersection (C) was then further evaluated for capacity hot spots during the weekday p.m. peak period (Example 2). Later, speed and travel time (Example 3), vehicular density and motorized vehicle LOS (Example 4), and queue lengths (Example 5) were estimated for individual sections within supersection C.

In this example, freeway reliability will be evaluated as described in Section H7 of the Guide. Two performance measures will be calculated: the 95th percentile travel time index and the percent of trips traveling under 45 mph. The method requires the following data, which were assembled or calculated in previous examples: section lengths, number of through lanes, demand served, capacities, and travel times.

### Step 1: Compute Vehicle-Miles Traveled

For each section and 15-minute time period, the mainline demand served is obtained from Example 2 and multiplied by the section length and the time period length to obtain the VMT. For example, for freeway section C-1 in time period 1, the mainline demand served is 3,336 veh/h, the section length is 0.05 miles, and the time period length is 0.25 hours. The VMT is then  $3,336 \times 0.05 \times 0.25 = 42$  veh-mi. Exhibit 153 shows the calculation results for all sections and time periods.

### Step 2: Compute Vehicle-Hours Traveled

For each section and 15-minute time period, the section travel time is obtained from Example 3 and multiplied by the mainline demand served and time period length to obtain the VHT. For example, for freeway section C-1 in time period 1, the mainline demand served is 3,336 veh/h, the section travel time is 2.9 seconds, and the time period length is 0.25 hours. The VHT is  $3,336 \times (2.9 \text{ s} / 3,600 \text{ s/h}) \times 0.25 \text{ h} = 0.67$  veh-h. Exhibit 153 shows the calculation results for all sections and time periods.

### Step 3: Compute Average Facility Speed for the Peak Hour

The section VMTs and VHTs are summed over the sections and the 15-minute time periods to obtain the grand totals for the facility (i.e., supersection C) for the weekday p.m. peak hour: 19,519 VMT and 464.3 VHT. Dividing the VHT into the VMT yields an average facility speed for the hour of 42.0 mph.

### Step 4: Compute Maximum Facility Demand-to-Capacity Ratio

The maximum d/c ratio observed over all sections and 15-minute time periods is obtained from Example 2. It occurs in section C-4 during time period 3, where the demand is 5,383 veh/h, compared to a capacity of 4,212 veh/h, corresponding to a d/c ratio of 1.28.

**Exhibit 153. Case study 1: p.m. peak hour VMT and VHT for supersection C (southbound).**

Section	C-1	C-2	C-3	C-4	C-5	C-6	C-7
<b>Section type</b>	Basic	Ramps	Basic	Ramps	Basic	Ramps	Basic
<b>Number of lanes</b>	2	2	2	2	2	2	2
<b>Section length (mi)</b>	0.05	1.65	0.24	1.51	0.37	0.81	0.18
<b>Time Period 1</b>							
<b>Served demand (veh/h)</b>	3,336	4,024	3,984	4,212	3,865	3,977	3,865
<b>VMT</b>	42	1,660	239	1,590	358	805	174
<b>Travel time (s)</b>	2.9	108.3	14.9	131.7	22.6	52.6	11.0
<b>VHT</b>	0.67	30.26	4.12	38.52	6.07	14.53	2.95
<b>Time Period 2</b>							
<b>Served demand (veh/h)</b>	3,626	4,212	4,171	4,212	3,872	3,994	3,872
<b>VMT</b>	45	1,737	250	1,590	358	809	174
<b>Travel time (s)</b>	2.9	130.9	15.5	183.8	22.4	52.0	10.9
<b>VHT</b>	0.73	38.29	4.49	53.76	6.02	14.42	2.93
<b>Time Period 3</b>							
<b>Served demand (veh/h)</b>	3,336	4,186	4,146	4,212	3,924	4,036	3,924
<b>VMT</b>	42	1,727	249	1,590	363	817	177
<b>Travel time (s)</b>	2.9	112.8	15.4	228.8	22.5	52.3	10.9
<b>VHT</b>	0.67	32.79	4.43	66.92	6.13	14.66	2.97
<b>Time Period 4</b>							
<b>Served demand (veh/h)</b>	3,046	3,674	3,637	4,212	3,943	4,045	3,943
<b>VMT</b>	38	1,516	218	1,590	365	819	177
<b>Travel time (s)</b>	2.8	100.7	14.1	215.1	22.6	52.6	11.0
<b>VHT</b>	0.59	25.69	3.56	62.92	6.19	14.78	3.01

**Step 5: Compute the Recurring Delay Rate**

The recurring delay rate for the facility is computed using Equation 33, found in Section H7 of the Guide.

$$RDR = \frac{1}{S} - \frac{1}{FFS} = \frac{1}{42.0} - \frac{1}{65} = 0.0084 \text{ h/mi}$$

Although this equation is likely to be most accurate at the facility level, it is also applied at the section level in this example to identify which sections are the biggest contributors to the facility’s reliability problems on the facility. The results are shown in Exhibit 154.

**Step 6: Compute the Incident Delay Rate**

The incident-caused delay rate for the facility is computed using Equation 34. Note that the volume-to-capacity ratio *X* used in the equation is capped at 1.00 when demand on the critical

**Exhibit 154. Case study 1: recurring delay rates for supersection C (southbound, p.m. peak hour).**

Section	C-1	C-2	C-3	C-4	C-5	C-6	C-7
<b>Section type</b>	Basic	Ramps	Basic	Ramps	Basic	Ramps	Basic
<b>Recurring delay rate (h/mi)</b>	0.0006	0.0035	0.0019	0.0181	0.0017	0.0028	0.0017

**Exhibit 155. Case study 1: incident delay rates for supersection C (southbound, p.m. peak hour).**

Section	C-1	C-2	C-3	C-4	C-5	C-6	C-7
<b>Section type</b>	Basic	Ramps	Basic	Ramps	Basic	Ramps	Basic
<b>Maximum <math>d/c</math> ratio</b>	0.82	1.04	0.94	1.28	0.89	0.96	0.89
<b>Incident delay rate (h/mi)</b>	0.0018	0.0200	0.0095	0.0200	0.0049	0.0123	0.0049

section within the facility exceeds capacity. The number of lanes is limited to 2, 3, or 4. For the facility:

$$IDR = [0.020 - (N - 2) \times 0.003] \times X^{12} = [0.020 - (2 - 2) \times 0.003] \times 1^{12} = 0.020 \text{ h/mi}$$

Although the equation is likely to be most accurate at the facility level, it is also applied at the section level in this example to identify which sections are the biggest contributors to the reliability problems on the facility. The results are shown in Exhibit 155.

**Step 7: Compute the Mean Travel Time Index**

The mean travel time index for the facility is computed using Equation 32. It is the ratio of the mean annual peak hour travel time (with incidents) to the travel time under free-flow conditions. The calculation for the facility is as follows:

$$TTI_m = 1 + FFS \times (RDR + IDR) = 1 + 65 \times (0.0084 + 0.0200) = 2.85$$

This result indicates that, on average, travel through supersection C during the weekday p.m. hour takes 2.85 times as long as under free-flow conditions, implying an average annual peak hour speed of  $65 / 2.85 = 22.8$  mph.

Although the mean travel time equation is likely to be most accurate at the facility level, it is also applied at the section level in this example to identify which sections are the biggest contributors to the reliability problems on the facility. The results are shown in Exhibit 156. Freeway sections C-2 and C-4 appear to be the greatest contributors to the peak hour reliability problems on the facility.

**Step 8: Compute the 95th Percentile Travel Time Index**

The 95th percentile travel time index for the facility is computed using Equation 35.

$$TTI_{95} = 1 + 3.67 \times \ln(TTI_m) = 1 + 3.67 \times \ln(2.85) = 4.84$$

The result of 4.84 implies that travel speeds through subsection C fall below 13.4 mph during 5% of the peak hours during the year.

**Exhibit 156. Case study 1: mean travel time index values for supersection C (southbound).**

Section	C-1	C-2	C-3	C-4	C-5	C-6	C-7
<b>Section type</b>	Basic	Ramps	Basic	Ramps	Basic	Ramps	Basic
<b>Recurring delay rate (h/mi)</b>	0.0006	0.0035	0.0019	0.0181	0.0017	0.0028	0.0017
<b>Incident delay rate (h/mi)</b>	0.0018	0.0200	0.0095	0.0200	0.0049	0.0123	0.0049
<b>Mean travel time index</b>	1.16	2.55	1.75	3.57	1.43	1.98	1.43

### Step 9: Compute Percent Trips Under 45 mph

The percent of peak hour trips over the year that travel at average speeds below 45 mph for the facility is computed using Equation 36.

$$PT_{45} = 1 - \exp[-1.5115 \times (TTI_m - 1)] = 1 - \exp[-1.5115 \times (2.85 - 1)] = 0.94$$

Approximately 94% of the peak hour trips in supersection C are completed at average speeds below 45 mph, which is to be expected when the average annual speed is 42.1 mph for recurring congestion (i.e., without incidents).

## 8. Example 7: Comparison of Overcongested Alternatives

### Approach

Previous examples demonstrated planning-level calculations of a variety of performance measures for supersection C, which showed that two sections of this facility, C-2 and C-4, operated poorly. This example illustrates how one might compare the performance effects of alternative mitigation measures, none of which completely eliminate congestion. In this case, the agency is choosing between two alternatives—doing nothing or adding a lane—neither of which is able to change LOS F conditions to any better than LOS F. This example shows how to numerically compare the improvement to the before condition and determine whether there is a net improvement in freeway operations, even though the facility will still operate at LOS F. This example also demonstrates that addressing capacity problems at one bottleneck may reveal other hidden bottlenecks downstream.

To analyze and compare the effects of the two alternatives, this example returns to Example 2, which identified v/c hot spots along the facility. The data and analysis results for the “Do Nothing” alternative are retrieved directly from Example 2, while the Example 2 calculations are repeated for the “Add Lane” alternative, but adding an auxiliary lane in freeway section C-4 to relieve the bottleneck.

### Analysis

The results for the “Do Nothing” alternative are obtained from Exhibit 143 through Exhibit 146 and summarized in Exhibit 157. The results for the “Add Lane” alternative are calculated as described herein and summarized in Exhibit 158.

In the “Add Lane” alternative, freeway section C-4 is modified by adding an auxiliary lane between the on-ramp and off-ramp. This transforms the section from a ramps section into a weave section, which requires the calculation of a new capacity adjustment factor. Equation 23, located in Section H6 of the Guide, is used to calculate this factor. As no information is available about specific movements (e.g., ramp-to-ramp demands) within the weaving section, the guidance from Section H6 of the Guide is followed to assume zero ramp-to-ramp demand, so that the volume ratio  $V_r$  is the sum of the on- and off-ramp volumes, divided by the sum of the mainline entering volume and the on-ramp volume. For freeway section C-4 during time period 1, using data from Exhibit 143 in Example 2, the on-ramp demand flow rate is 488 veh/h, the off-ramp demand flow rate is 368 veh/h, and the mainline entering flow rate is 3,984 veh/h. Then:

$$V_r = \frac{488 + 368}{3,984 + 488} = 0.191$$

**Exhibit 157. Case study 1: d/c results for the “do nothing” alternative.**

Section	C-1	C-2	C-3	C-4	C-5	C-6	C-7
<b>Section type</b>	Basic	Ramps	Basic	Ramps	Basic	Ramps	Basic
<b>Section capacity (veh/h)</b>	4,434	4,212	4,434	4,212	4,434	4,212	4,434
<b>Time Period 1</b>							
<b>Mainline demand (veh/h)</b>	3,336						
<b>On-ramp demand (veh/h)</b>		688		488		112	
<b>Off-ramp demand (veh/h)</b>		40		368		112	
<b>Entering demand (veh/h)</b>	3,336	4,024	3,984	4,472	3,865	3,977	3,865
<b>d/c ratio</b>	0.75	0.96	0.90	1.06	0.87	0.94	0.87
<b>Mainline vol. served (veh/h)</b>	3,336	3,984	3,984	3,865	3,865	3,865	3,865
<b>Time Period 2</b>							
<b>Mainline demand (veh/h)</b>	3,626						
<b>Carryover demand (veh/h)</b>	0	0	0	260	0	0	0
<b>On-ramp demand (veh/h)</b>		748		530		122	
<b>Off-ramp demand (veh/h)</b>		43		400		122	
<b>Entering demand (veh/h)</b>	3,626	4,374	4,171	4,961	3,872	3,994	3,872
<b>d/c ratio</b>	0.82	1.04	0.94	1.18	0.87	0.95	0.87
<b>Mainline vol. served (veh/h)</b>	3,626	4,171	4,171	3,872	3,872	3,872	3,872
<b>Time Period 3</b>							
<b>Mainline demand (veh/h)</b>	3,336						
<b>Carryover demand (veh/h)</b>	0	162	0	749	0	0	0
<b>On-ramp demand (veh/h)</b>		688		488		112	
<b>Off-ramp demand (veh/h)</b>		40		368		112	
<b>Entering demand (veh/h)</b>	3,336	4,186	4,146	5,383	3,924	4,036	3,924
<b>d/c ratio</b>	0.75	0.99	0.94	1.28	0.88	0.96	0.88
<b>Mainline vol. served (veh/h)</b>	3,336	4,146	4,146	3,924	3,924	4,036	3,924
<b>Time Period 4</b>							
<b>Mainline demand (veh/h)</b>	3,046						
<b>Carryover demand (veh/h)</b>	0	0	0	1,169	0	0	0
<b>On-ramp demand (veh/h)</b>		628		446		102	
<b>Off-ramp demand (veh/h)</b>		37		336		102	
<b>Entering demand (veh/h)</b>	3,046	3,674	3,637	5,252	3,943	4,045	3,943
<b>d/c ratio</b>	0.69	0.87	0.82	1.25	0.89	0.96	0.89
<b>Mainline vol. served (veh/h)</b>	3,046	3,637	3,637	3,943	3,943	4,045	3,943
<b>Full Hour</b>							
<b>Section demand (veh/h)</b>	3,336	4,024	3,984	4,472	3,865	3,977	3,865
<b>Demand served (veh/h)</b>	3,336	4,024	3,984	4,212	3,865	3,977	3,865
<b>Average d/c ratio</b>	0.75	0.96	0.90	1.19	0.88	0.95	0.88
<b>Maximum d/c ratio</b>	0.82	1.04	0.94	1.28	0.89	0.96	0.89

Note: vol. = volume.

**Exhibit 158. Case study 1: d/c results for the “add lane” alternative.**

Section	C-1	C-2	C-3	C-4	C-5	C-6	C-7
<b>Section type</b>	Basic	Ramps	Basic	Weave	Basic	Ramps	Basic
<b>Section capacity (veh/h)</b>	4,434	4,212	4,434	6,651	4,434	4,212	4,434
<b>Time Period 1</b>							
<b>Mainline demand (veh/h)</b>	3,336						
<b>On-ramp demand (veh/h)</b>		688		488		112	
<b>Off-ramp demand (veh/h)</b>		40		368		112	
<b>Entering demand (veh/h)</b>	3,336	4,024	3,984	4,472	4,104	4,216	4,100
<b>d/c ratio</b>	0.75	0.96	0.90	0.71	0.93	1.00	0.92
<b>Mainline vol. served (veh/h)</b>	3,336	3,984	3,984	4,104	4,104	4,100	4,100
<b>Time Period 2</b>							
<b>Mainline demand (veh/h)</b>	3,626						
<b>Carryover demand (veh/h)</b>	0	0	0	0	0	4	0
<b>On-ramp demand (veh/h)</b>		748		530		122	
<b>Off-ramp demand (veh/h)</b>		43		400		122	
<b>Entering demand (veh/h)</b>	3,626	4,374	4,171	4,701	4,301	4,427	4,096
<b>d/c ratio</b>	0.82	1.04	0.94	0.74	0.97	1.05	0.92
<b>Mainline vol. served (veh/h)</b>	3,626	4,171	4,171	4,701	4,301	4,096	4,096
<b>Time Period 3</b>							
<b>Mainline demand (veh/h)</b>	3,336						
<b>Carryover demand (veh/h)</b>	0	162	0	0	0	213	0
<b>On-ramp demand (veh/h)</b>		688		488		112	
<b>Off-ramp demand (veh/h)</b>		40		368		112	
<b>Entering demand (veh/h)</b>	3,336	4,186	4,146	4,634	4,266	4,593	4,109
<b>d/c ratio</b>	0.75	0.99	0.94	0.73	0.96	1.09	0.93
<b>Mainline vol. served (veh/h)</b>	3,336	4,146	4,146	4,266	4,266	4,109	4,109
<b>Time Period 4</b>							
<b>Mainline demand (veh/h)</b>	3,046						
<b>Carryover demand (veh/h)</b>	0	0	0	0	0	379	0
<b>On-ramp demand (veh/h)</b>		628		446		102	
<b>Off-ramp demand (veh/h)</b>		37		336		102	
<b>Entering demand (veh/h)</b>	3,046	3,674	3,638	4,083	3,747	4,230	4,110
<b>d/c ratio</b>	0.69	0.87	0.82	0.65	0.85	1.00	0.93
<b>Mainline vol. served (veh/h)</b>	3,046	3,638	3,638	3,747	3,747	4,110	4,110
<b>Full Hour</b>							
<b>Section demand (veh/h)</b>	3,336	4,024	3,984	4,472	4,104	4,216	4,100
<b>Demand served (veh/h)</b>	3,336	4,024	3,984	4,472	4,104	4,212	4,100
<b>Average d/c ratio</b>	0.75	0.96	0.90	0.71	0.93	1.04	0.93
<b>Maximum d/c ratio</b>	0.82	1.04	0.94	0.74	0.97	1.09	0.93

Note: vol. = volume.



**Exhibit 159. Case study 1: comparison of average d/c ratios.**

Scenario	C-1	C-2	C-3	C-4	C-5	C-6	C-7
Do Nothing	0.75	0.96	0.90	1.19	0.88	0.95	0.88
Add Lane	0.75	0.96	0.90	0.71	0.93	1.04	0.93

$$CAF_{weave} = 0.884 - 0.0752V_r + 0.0000243L_s \leq 1.00$$

$$CAF_{weave} = 0.884 - 0.0752(0.191) + 0.0000243(1.51 \text{ mi} \times 5,280 \text{ ft/mi}) = 1.06 \Rightarrow 1.00$$

The capacity of freeway section C-4 during time period 1 is determined from Equation 16:

$$c_{C-4} = \frac{(2,200 + 10 \times (\min(70, S_{FFS}) - 50))}{1 + \%HV/100} \times CAF$$

$$c_{C-4} = \frac{(2,200 + 10 \times (\min(70, 65) - 50))}{1 + 6/100} \times 1.00$$

$$c_{C-4} = 2,217 \text{ veh/h/ln}$$

Because the relative proportions of weaving and non-weaving volumes may vary during the peak hour, the volume ratio, the CAF, and ultimately the section capacity may also vary in each time period. However, in this case, the weaving section is long enough that  $CAF_{weave}$  exceeds 1.00 in all time periods and therefore is constrained to 1.00 in all time periods, with the result that section C-4’s capacity is the same in all time periods.

**Interpretation**

Exhibit 159 provides a side-by-side comparison of the average peak hour d/c ratios for each section for the two alternatives. Adding a lane to freeway section C-4 has no effect on the upstream sections C-1, C-2, and C-3; significantly improves the d/c ratio for Section C-4; and significantly worsens the d/c ratios for the downstream sections C-5, C-6, and C-7.

It is hard to say which alternative is better until one computes the volume- and distance-weighted average d/c ratio for the facility under each alternative. The section demands are multiplied by the section lengths to get VMT demanded. The section capacities are multiplied by the section lengths to get VMT of capacity. The result is an average d/c ratio of 1.01 for the Do Nothing alternative, and 0.86 for the Add Lane alternative. Therefore, Add Lane is the more-effective alternative.

Using an average d/c ratio can give the mistaken impression that somehow the Add Lane alternative has solved the freeway’s congestion problems on the freeway. Examination of Exhibit 159, however, shows that this is clearly not the case. Congestion on a freeway facility is driven by its critical bottleneck; therefore, it is better to compare the worst case d/c ratios on the facility under each alternative. Exhibit 160 shows such a comparison.

**Exhibit 160. Case study 1: comparison of maximum d/c ratios.**

Scenario	C-1	C-2	C-3	C-4	C-5	C-6	C-7
Do Nothing	0.82	1.04	0.94	1.28	0.89	0.96	0.89
Add Lane	0.82	1.04	0.94	0.74	0.97	1.09	0.93

**Exhibit 161. Case study 1: comparison of freeway performance for the two alternatives.**

	Time Period				Full Hour
	1	2	3	4	
<b>Do Nothing Alternative</b>					
Facility travel time (min)	5.7	7.0	7.5	7.0	6.9
Space mean speed (mph)	50.3	41.3	38.7	41.2	42.0
Facility density (veh/mi/ln)	53.2	66.3	70.7	64.1	63.6
Total queue length (mi)	2.6	7.0	6.6	6.3	5.6
Facility LOS	F	F	F	F	F
Maximum d/c ratio on facility	1.06	1.18	1.28	1.25	1.19
<b>Add Lane Alternative</b>					
Facility travel time (min)	5.0	5.8	5.8	4.9	5.4
Space mean speed (mph)	57.3	49.5	49.6	59.1	53.6
Facility density (veh/mi/ln)	48.1	57.6	57.1	43.6	51.6
Total queue length (mi)	0.1	3.6	2.7	0.2	1.7
Facility LOS	F	F	F	F	F
Maximum d/c ratio on facility	1.00	1.05	1.09	1.00	1.09

Notes: The total travel time for the hour is the volume-weighted average of the 15-minute time periods.  
 The space mean speed for the hour is the inverse of the average total travel time.  
 The density and queue length for the hour are simple averages of the 15-minute values.  
 The facility LOS and the maximum d/c ratio for the hour are the worst of the 15-minute periods.

Again, the results are ambivalent until one compares the worst case d/c ratio under each alternative. The worst case d/c ratio for the Do Nothing alternative is 1.28 in freeway section C-4. The worst case d/c ratio for the Add Lane alternative is 1.09 in section C-6. Again, Add Lane is the more-effective alternative.

These conclusions are confirmed by computing and comparing the freeway performance measures under each alternative following the procedures illustrated in the previous example problems. The results are shown in Exhibit 161.

## 9. Reference

California Department of Transportation. *Caltrans Journal*, Vol. 2, Issue 6, May–June 2002.



## U. Case Study 2: Arterial BRT Analysis



### 1. Overview

This case study addresses the implementation of a 14.4-mile bus rapid transit (BRT) line connecting Berkeley, Oakland, and San Leandro, California, on Telegraph Avenue and International Blvd. The proposed route and study area are shown in Exhibit 162. There are a total of 110 signalized and 19 stop-controlled intersections along the proposed BRT route. A screening method will be used to identify the focus sections for more-intense analysis.

### Planning Objective

The agency's planning objective is to identify the traffic, transit, pedestrian, and bicycle impacts of the proposed BRT project.

### Background

The BRT route will run primarily on Telegraph Avenue and International Blvd.:

- Telegraph Avenue is a 4-lane divided and undivided arterial, with posted speed limits of 25 to 30 mph, with curbside parallel parking and continuous sidewalks on both sides.
- International Blvd. has similar geometric, speed limit, parking, and sidewalk characteristics as Telegraph Avenue (AC Transit 2012).
- Peak hour directional through volumes on both streets range from 400 to 1,000 vehicles per hour.
- Eight intersections on the project alignment regularly experience peak hour LOS E/F conditions (before project implementation).

The BRT project includes bus priority at traffic signals, exclusive bus-only lanes, and elimination of some through lanes and left turns. Curbside parking is generally retained between BRT stations. Curbside parking is lost at most BRT stations.

### Example Problems Worked in this Case Study

The planning problems to be illustrated by worked examples are:

- Example 1: Preliminary Screening with Service Volume Tables
- Example 2: Computing Critical Intersection Volume-to-Capacity Ratios
- Example 3: Calculating Intersection v/c Ratios with Permitted Left Turns

**Exhibit 162. Case study 2: study area.**

- Example 4: Estimating Auto and BRT Speeds
- Example 5: Predicting Queue Hot Spots
- Example 6: Pedestrian, Bicycle, and Transit LOS

The HCM does not currently address the analysis of truck LOS for urban streets, so truck LOS analysis is excluded from this case study.

## 2. Example 1: Preliminary Screening with Service Volume Tables

### Approach

To reduce the resources required to evaluate the environmental impacts of the proposed BRT project, the 14-mile route length will be split into supersections where traffic demands, roadway geometry, and signal timing are relatively similar. HCM service volume tables will then be used to screen the average LOS for these supersections, as described in Section K4 of the Guide. Next, motorized vehicle LOS will be assessed after removing one through lane in each direction and dedicating the space exclusively to BRT. Supersections with LOS in the E/F range will be selected for more detailed analyses in subsequent example problems within this case study.

### Step 1: Divide the BRT Route into Supersections

The BRT route is divided into supersections on the basis of a significant change in:

- Posted speed limit,
- Number of through lanes,
- Median presence, or
- Traffic demand (such as a major trip generator).

The resulting 10 supersections are listed in Exhibit 163.

**Exhibit 163. Case study 2: analysis supersections.**

Super-section	Street	Limits	Length (mi)	Peak Volume (1-dir.)	Speed Limit (mph)	No. of Lanes (1-dir.)	Median
A	Telegraph Ave.	Dwight to Woolsey	0.84	910	25	2	No
B	Telegraph Ave.	Woolsey to SR 24	0.80	1,010	30	2	No
C	Telegraph Ave.	SR 24 to 45th	0.60	910	30	2	TWLTL
D	Telegraph Ave.	45th to Broadway	2.01	890	25	2	TWLTL
E	International Blvd.	Lake Merritt to 23rd	1.58	420	30	2	No
F	International Blvd.	23rd to 35th	0.87	550	25	2	No
G	International Blvd.	35th to High	0.51	660	25	2	TWLTL
H	International Blvd.	High to Hegenberger	1.78	560	30	2	TWLTL
I	International Blvd.	Hegenberger to 98th	1.37	610	30	2	TWLTL
J	International Blvd.	98th to Dutton	1.06	460	30	2	TWLTL

Notes: TWLTL = two-way left-turn lane, dir. = direction.

Several sections of other streets along the BRT route have been left out of the example for the sake of clarity. The same screening approach would be applied to these sections as well.

Several sections of other streets along the BRT route have been left out of the example for clarity's sake. The same screening approach would be applied to these sections as well.

**Step 2: Obtain AADT Estimates for Supersections**

In this example, AADT volumes are not available for each supersection, but peak hour counts are available, as are data from a few permanent traffic recorders located on other arterial streets. These traffic recorders indicate that typical peak hour traffic in the area is approximately 10% of the daily traffic and that 55% of peak hour traffic travels in the peak direction. Therefore, supersection AADTs are estimated by dividing the peak hour volume of the most heavily traveled portion of each supersection by 0.10 and 0.55. The resulting AADTs are shown in Exhibit 164.

**Step 3: Select Service Volumes for Supersections**

Because this is a preliminary screening process to identify which sections of the BRT route require additional analysis, it is recommended that the analyst select a conservatively good

**Exhibit 164. Case study 2: service volume screening results.**

Super-section	Street	Limits	AADT	Before BRT		After BRT	
				Through Lanes (2-dir.)	LOS D Service Volume	Through Lanes (2-dir.)	LOS D Service Volume
A	Telegraph Ave.	Dwight to Woolsey	16,550	4	22,300	2	<b>10,700</b>
B	Telegraph Ave.	Woolsey to SR 24	18,360	4	22,300	2	<b>10,700</b>
C	Telegraph Ave.	SR 24 to 45th	16,550	4	22,300	2	<b>10,700</b>
D	Telegraph Ave.	45th to Broadway	16,180	4	22,300	2	<b>10,700</b>
E	International Blvd.	Lake Merritt to 23rd	7,640	4	22,300	2	10,700
F	International Blvd.	23rd to 35th	10,000	4	22,300	2	10,700
G	International Blvd.	35th to High	12,000	4	22,300	2	<b>10,700</b>
H	International Blvd.	High to Hegenberger	10,180	4	22,300	2	10,700
I	International Blvd.	Hegenberger to 98th	11,090	4	22,300	2	<b>10,700</b>
J	International Blvd.	98th to Dutton	8,360	4	22,300	2	10,700

Notes: AADT = annual average daily traffic, dir. = direction.

Service volumes in **bold** indicate supersections where operations are estimated to be worse than LOS D.

LOS for the screening. In this case the agency's policy is to maintain LOS E for motorized vehicles, so for screening purposes, the service volume threshold for motorized vehicle LOS D will be used.

Exhibit 45 in Section K4 of the Guide is used for the screening. As this service volume table only provides two choices of posted speeds (30 and 45 mph), the section for a 30-mph posted speed is used for supersections with posted speeds of both 25 and 30 mph, as 30 mph is closer to 25 mph than 45 mph. The LOS D service volume for "Before BRT" (i.e., existing) conditions is then read from the LOS D column for four-lane streets (i.e., two through lanes in each direction), using the previously determined *K*-factor of 0.10 and *D*-factor of 0.55.

The process is repeated for the "After BRT" conditions, except that only one through lane will be provided for general traffic once the exclusive BRT lane is constructed. Therefore, the LOS D column for two-lane streets (i.e., one through lane in each direction) is used to determine the "After BRT" service volume. The results of the evaluation are shown in Exhibit 164.

#### **Step 4: Identify Supersections for Further Analysis**

The AADTs are compared to the service volumes to identify those supersections requiring further analysis. Six supersections (A, B, C, D, G, and I) are retained for further analysis, and four are dropped from further analysis.

#### **Interpretation of Results**

The screening analysis shows that all supersections currently have spare capacity, and that for four of them, the dedication of one through lane in each direction to BRT would not reduce the auto LOS below D. For the six other supersections, the screening analysis suggests that there may be some capacity problems requiring more-detailed evaluation.

The remaining examples in this case study will focus on just one of the supersections: the stretch of Telegraph Avenue between State Route 24 and 45th Street, supersection C.

### **3. Example 2: Computing Critical Intersection Volume-to-Capacity Ratios**

#### **Approach**

Example 1 divided the study corridor into 10 supersections for screening and found that six supersections were likely to experience LOS E or F operations following the dedication of one travel lane in each direction to BRT. This example will focus on one of these supersections and will evaluate which intersections within the supersection will likely experience LOS problems if the number of through lanes is reduced, following the process described in Section L4 of the Guide.

Usually, the signalized intersections on an urban street will be its critical capacity choke points. Therefore, this example will examine peak hour intersection *v/c* ratios at these intersections to determine which ones should be evaluated in more detail. Should there be some other capacity choke point (such as a lane drop, a narrow bridge or tunnel, a major shopping center driveway, or a major grade change) then those choke points should be checked as well. Exhibit 165 provides lane configurations and peak hour turning-movement volumes for the major signalized intersections within supersection C.

**Exhibit 165. Case study 2: intersection lane configurations and turning-movement volumes.**

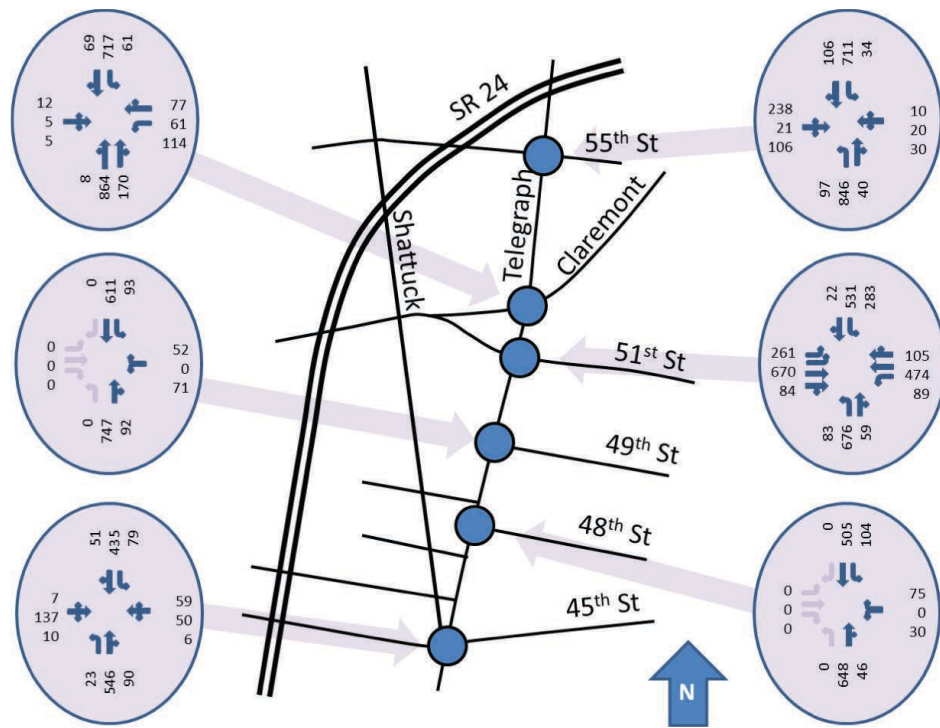

**Step 0: Assemble Data**

The turning-movement volumes and lane configurations for the six major intersections in supersection C were shown in Exhibit 165. According to Exhibit 60 in Section L3 of the Guide, the following additional data are required to evaluate capacity:

- Peak hour factor,
- Percent heavy vehicles,
- Parking activity, and
- Pedestrian activity.

For the intersection of Telegraph and 51st Street, the traffic counts used to develop the turning-movement volumes are also used to identify the values for peak hour factor (0.92) and percent heavy vehicles (5%), and to characterize the pedestrian activity at the intersection as “Medium.” The analyst’s knowledge is used to determine that parking is allowed on 51st Street, but will not be allowed on Telegraph Avenue following construction of the exclusive BRT lane. The remainder of this example will show the computations for this intersection. Computations for the other intersections are similar.

**Step 1: Determine Left-Turn Phasing**

The future left-turn phasing is not known. Therefore, the process for selecting left-turn phasing described in Section L4 of the Guide will be used. Protected left-turn phasing is selected if any of the following three conditions are met; otherwise, permitted left-turn phasing is selected:

- Left-turn volume exceeds 240 veh/h;
- The product of the left-turn volume and the opposing through volume exceeds a given threshold (50,000 if there is one opposing through lane, 90,000 if there are two opposing through lanes, and 110,000 if there are three or more opposing through lanes); or
- The number of left-turn lanes exceeds one.

If an approach has an exclusive left-turn lane, and its opposing approach meets at least one condition for protected left-turn phasing, then it will also be assumed to have protected left-turn phasing.

Exhibit 166 shows the results of these checks. In this case, the southbound and eastbound approaches met one or more of the conditions for protected left-turn phasing. Because their opposing approaches (northbound and westbound, respectively) have exclusive left-turn lanes, the opposing approaches are also assumed to have protected left turns.

### Step 2: Identify Lane Groups

The turn volumes are assigned to lane groups according the criteria given in Section L4 of the Guide:

1. When a traffic movement uses only an exclusive lane(s), it is analyzed as an exclusive lane group.
2. When two or more traffic movements share a lane, all lanes which convey those traffic movements are analyzed as a mixed lane group.

By these criteria, all left-turn movements at this intersection are assigned to exclusive lane groups, while all through and right-turn movements are assigned to mixed lane groups. Multiple-lane mixed lane groups also need to be examined to determine whether a de facto turn lane exists, due to a high volume of turning traffic relative to through traffic. As shown in Exhibit 167, only the westbound and eastbound approaches have mixed lane groups with two or more lanes. The right-turn volumes on these approaches are small relative to the through volumes; no de facto turn lanes exist, and the original assignment of a mixed lane group is retained.

**Exhibit 166. Case study 2: protected left-turn checks for Telegraph Avenue/51st Street.**

		Approach			
		NB	SB	WB	EB
<b>Check 1</b>	<b>Left-turn volume (veh/h)</b>	83	283	89	261
	<b>Is the left-turn volume &gt; 240 veh/h?</b>	No	Yes	No	Yes
<b>Check 2</b>	<b>Opposing through volume (veh/h)</b>	531	676	670	474
	<b>Left-turn volume × opposing volume</b>	44,073	191,308	59,630	123,714
	<b>Number of opposing through lanes</b>	1	1	2	2
	<b>Threshold for Check 2</b>	50,000	50,000	90,000	90,000
	<b>Is product &gt; threshold?</b>	No	Yes	No	Yes
<b>Check 3</b>	<b>Left-turn lanes</b>	1	1	1	2
	<b>Is there more than 1 left-turn lane?</b>	No	No	No	Yes
<b>Check 4</b>	<b>Is there an exclusive left-turn lane?</b>	Yes	Yes	Yes	Yes
	<b>Does the opposite approach meet Check 1, 2, or 3?</b>	Yes	No	Yes	No
<b>Result</b>	<b>Protected left-turn phase?</b>	Yes	Yes	Yes	Yes

Note: NB = northbound, SB = southbound, WB = westbound, EB = eastbound.



**Exhibit 167. Case study 2: lane group determination for Telegraph Avenue/51st street.**

	Northbound			Southbound			Westbound			Eastbound		
	L	T	R	L	T	R	L	T	R	L	T	R
Peak hour volume (veh/h)	83	676	59	283	531	22	89	474	105	261	670	84
Number of lanes	1	1		1	1		1	2		2	2	
De facto exclusive lane?								No			No	
Lane group type	Ex.	Mixed		Ex.	Mixed		Ex.	Mixed		Ex.	Mixed	

Note: L = left, T = through, R = right, Ex. = Exclusive.

### Step 3: Convert Turning Movements to Through Passenger Car Equivalents

This step converts turning movements to through passenger car equivalents, considering the effect of heavy vehicles, variations in traffic flow during the hour, the impact of opposing through vehicles on permitted left-turning vehicles, the impact of pedestrians on right-turning vehicles, lane utilization, and the impact of parking maneuvers on through and right-turning vehicles.

#### Step 3a: Heavy Vehicle Adjustment

The adjustment for heavy vehicles  $E_{HVadj}$  is calculated using Equation 75.

$$E_{HVadj} = 1 + P_{HV} (E_{HV} - 1) = 1 + 0.05(2 - 1) = 1.05$$

#### Step 3b: Peak Hour Factor Adjustment

The adjustment for variation in flow during the peak hour is calculated using Equation 76.

$$E_{PHF} = \frac{1}{PHF} = \frac{1}{0.92} = 1.09$$

#### Step 3c: Turn Impedance Adjustment

The turn impedance adjustment factors  $E_{LT}$  and  $E_{RT}$  adjust for impedances experienced by left- and right-turning vehicles, respectively. For protected left turns (the situation on all four intersection approaches),  $E_{LT} = 1.05$  regardless of volume. For permitted right turns (the typical situation), Exhibit 63 is used to determine the value of  $E_{RT}$ . For a “Medium” level of pedestrian activity,  $E_{RT} = 1.30$ .

#### Step 3d: Parking Adjustment Factor

The parking adjustment factor  $E_p$  is determined from Exhibit 64. For exclusive left-turn lanes and all movements on Telegraph Avenue, where no adjacent on-street parking is provided,  $E_p = 1.00$ . For the eastbound and westbound through lane groups on 51st Street, which each have two lanes and adjacent parking,  $E_p = 1.10$ .

#### Step 3e: Lane Utilization Factor

The lane utilization factor  $E_{LU}$  is determined from Exhibit 65. For the northbound, southbound, and westbound exclusive left-turn lanes,  $E_{LU} = 1.00$ , as only one left-turn lane is provided. Two exclusive lanes are provided for the eastbound left turn; therefore, its  $E_{LU} = 1.03$ . In the northbound and southbound directions, one shared through–right lane is provided, with

**Exhibit 168. Case study 2: through passenger car equivalents for Telegraph Avenue/51st street.**

	Northbound			Southbound			Westbound			Eastbound		
	L	T	R	L	T	R	L	T	R	L	T	R
<b>Movement volume (veh/h)</b>	83	676	59	283	531	22	89	474	105	261	670	84
<b>Heavy vehicle adj., <math>E_{HVadj}</math></b>	1.05	1.05	1.05	1.05	1.05	1.05	1.05	1.05	1.05	1.05	1.05	1.05
<b>PHF adj., <math>E_{PHF}</math></b>	1.09	1.09	1.09	1.09	1.09	1.09	1.09	1.09	1.09	1.09	1.09	1.09
<b>Left-turn impedance adj., <math>E_{LT}</math></b>	1.05	1.00	1.00	1.05	1.00	1.00	1.05	1.00	1.00	1.05	1.00	1.00
<b>Right-turn impedance adj., <math>E_{RT}</math></b>	1.00	1.00	1.30	1.00	1.00	1.30	1.00	1.00	1.30	1.00	1.00	1.30
<b>Parking adj., <math>E_p</math></b>	1.00	1.00	1.00	1.00	1.00	1.00	1.00	1.10	1.10	1.00	1.10	1.10
<b>Lane utilization adj., <math>E_{LU}</math></b>	1.00	1.00	1.00	1.00	1.00	1.00	1.00	1.05	1.05	1.03	1.05	1.05
<b>Other effects adj., <math>E_{other}</math></b>	1.00	1.00	1.00	1.00	1.00	1.00	1.00	1.00	1.00	1.00	1.00	1.00
<b>Equivalent flow rate (tpc/h)</b>	100	774	88	340	608	33	107	627	180	323	886	144
<b>Number of lanes</b>	1		1	1		1	1		2	2		2
<b>Lane group type</b>	Ex.	Mixed		Ex.	Mixed		Ex.	Mixed		Ex.	Mixed	
<b>Lane group flow rate (tpc/h)</b>	100	862		340	641		107	807		323	1,030	
<b>Equivalent flow rate (tpc/h/ln)</b>	100	862		340	641		107	404		323	515	

Note: L = left, T = through, R = right, adj. = adjustment, PHF = peak hour factor, Ex. = Exclusive.

$E_{LU} = 1.00$ . In the eastbound and westbound directions, two through or shared lanes are provided, with  $E_{LU} = 1.05$ .

**Step 3f: Adjustment Factor for Other Effects**

In the absence of information on other effects,  $E_{other}$  is set to the default 1.00.

**Step 3g: Through Passenger Car Equivalent Flow Rate**

The through passenger car equivalent flow rate  $v_{adj}$  is calculated using Equation 78. For the northbound left-turn, the calculation is as follows:

$$v_{adj,NBLT} = VE_{HVadj}E_{PHF}E_{LT}E_{RT}E_pE_{LU}E_{other}$$

$$v_{adj,NBLT} = (83)(1.05)(1.09)(1.05)(1.00)(1.00)(1.00)(1.00) = 100 \text{ tpc/h}$$

**Step 3h: Equivalent Per-Lane Flow Rate**

Finally, the equivalent per-lane flow rate  $v_i$  for a given lane group  $i$  is calculated using Equation 79. For the northbound left-turn, which operates in a single lane, the calculation is:

$$v_{NBLT} = \frac{v_{adj,NBLT}}{N_{NBLT}} = \frac{100}{1} = 100 \text{ tpc/h/ln}$$

Exhibit 168 shows the computation results for all lane groups.

**Step 4: Calculate Critical Lane Group Volumes**

**Step 4a: Identify Critical Movements**

When opposing approaches use protected left-turn phasing, as is the case at this intersection, Equation 80 and Equation 81 are used to determine the critical lane group volumes in the east–west and north–south directions, respectively.

$$v_{c,EW} = \max \left\{ \begin{array}{l} v_{EBLT} + \max(v_{WBTH}, v_{WBRT}) \\ v_{WBTL} + \max(v_{EBTH}, v_{EBRT}) \end{array} \right\} = \max \left\{ \begin{array}{l} 323 + 404 \\ 107 + 515 \end{array} \right\} = \max \left\{ \begin{array}{l} 727 \\ 622 \end{array} \right\} = 727 \text{ tpc/h/ln}$$

Similarly for the north–south approaches, the critical volume  $V_{c,NS}$  is calculated using Equation 81.

$$v_{c,NS} = \max \left\{ \begin{array}{l} v_{NBLT} + \max(v_{SBTH}, v_{SBRH}) \\ v_{SBLT} + \max(v_{NBTH}, v_{NBRH}) \end{array} \right\} = \max \left\{ \begin{array}{l} 100 + 641 \\ 340 + 862 \end{array} \right\} = \max \left\{ \begin{array}{l} 741 \\ 1,202 \end{array} \right\} = 1,202 \text{ tpc/h/ln}$$

The critical lane group volumes for the intersection of Telegraph Avenue and 51st Street are: northbound through (862 tpc/h/ln); southbound left (340 tpc/h/ln); eastbound left (323 tpc/h/ln); and westbound through (404 tpc/h/ln).

#### *Step 4b: Calculate the Sum of the Critical Lane Group Volumes*

The sum of the critical lane group volumes is calculated using Equation 87.

$$V_c = v_{c,EW} + v_{c,NS} = 727 + 1,202 = 1,929 \text{ tpc/h/ln}$$

### **Step 5: Compute Intersection Volume-to-Capacity Ratio**

The intersection v/c ratio is computed using Equation 88. The capacity is assumed to be the default 1,650 tpc/h/ln suggested in Section L4 of the Guide.

$$X_c = \frac{V_c}{c_i} = \frac{1,929}{1,650} = 1.17$$

Applying the guidance provided in Exhibit 66, it is determined that the intersection will likely operate over capacity with the proposed lane geometry. The demands are likely to exceed the intersection's capacity under most feasible signal timing plans.

### **Interpretation of v/c Results for the Entire Facility**

An analysis of all six major intersections within supersection C found that Telegraph Avenue/51st Street is the only intersection where the predicted v/c ratio is expected to be over capacity following implementation of the BRT project (results for other intersections are presented in Example 4).

It is concluded that the Telegraph Avenue/51st Street intersection will likely have insufficient auto capacity under the proposed lane geometry with the BRT project in place. Consequently, a more detailed analysis using more site-specific data and fewer default values is recommended for the intersection, using actual or planned signal timings to compute delays and queues with the BRT project in place.

## **4. Example 3: Calculation of Intersection v/c Ratio for Permitted Left Turns**

### **Approach**

Example 2 showed the v/c ratio computations for an intersection with all protected left-turn phases. This example shows the computations for an intersection with all permitted left-turn phases, the intersection of Telegraph Avenue and Claremont Avenue. This example follows the process described in Section L4 of the Guide and uses the same steps as in Example 2.

## Step 0: Assemble Data

The turning-movement volumes and lane configurations for this intersection were shown in Exhibit 165 in Example 2. According to Exhibit 60 in Section L3 of the Guide, the following additional data are required to evaluate capacity:

- Peak hour factor,
- Percent heavy vehicles,
- Parking activity, and
- Pedestrian activity.

For the intersection of Telegraph Avenue and Claremont Avenue, the traffic counts used to develop the turning-movement volumes are also used to identify the values for peak hour factor (0.92) and percent heavy vehicles (5%), and to characterize the pedestrian activity at the intersection as “Medium.” The analyst’s knowledge is used to determine that parking is allowed on Claremont Avenue, but will not be allowed on Telegraph Avenue following construction of the exclusive BRT lane.

## Step 1: Determine Left-Turn Phasing

The future left-turn phasing is not known. Therefore, the process for selecting left-turn phasing described in Section L4 of the Guide will be used. Protected left-turn phasing is selected if any of the following three conditions are met; otherwise, permitted left-turn phasing is selected:

- Left-turn volume exceeds 240 veh/h;
- The product of the left-turn volume and the opposing through volume exceeds a given threshold (50,000 if there is one opposing through lane, 90,000 if there are two opposing through lanes, and 110,000 if there are three or more opposing through lanes); or
- The number of left-turn lanes exceeds one.

If an approach has an exclusive left-turn lane, and its opposing approach meets at least one condition for protected left-turn phasing, then it will also be assumed to have protected left-turn phasing.

Exhibit 169 shows the results of these checks. In this case, none of the approaches met one or more of the conditions for protected left-turn phasing. Therefore, permitted left-turn phasing will be assumed for all approaches.

## Step 2: Identify Lane Groups

The turn volumes are assigned to lane groups according to the criteria given in Section L4 of the Guide:

1. When a traffic movement uses only an exclusive lane(s), it is analyzed as an exclusive lane group.
2. When two or more traffic movements share a lane, all lanes which convey those traffic movements are analyzed as a mixed lane group.

By these criteria, the southbound and westbound left-turn movements at this intersection are assigned to exclusive lanes. All other movements are assigned to mixed lane groups. Multiple-lane mixed lane groups also need to be examined to determine whether a de facto turn lane exists, due to a high volume of turning traffic relative to through traffic. As shown in Exhibit 170, only the northbound approach has a mixed lane group with multiple lanes. In this case, both the

**Exhibit 169. Case study 2: protected left-turn checks for Telegraph Avenue/Claremont Avenue.**

		Approach			
		NB	SB	WB	EB
<b>Check 1</b>	<b>Left-turn volume (veh/h)</b>	8	61	114	12
	<b>Is the left-turn volume &gt; 240 veh/h?</b>	No	No	No	No
<b>Check 2</b>	<b>Opposing through volume (veh/h)</b>	717	864	5	61
	<b>Left-turn volume × opposing volume</b>	5,736	52,704	570	732
	<b>Number of opposing through lanes</b>	1	2	1	1
	<b>Threshold for Check 2</b>	50,000	90,000	50,000	50,000
	<b>Is product &gt; threshold?</b>	No	No	No	No
<b>Check 3</b>	<b>Left-turn lanes</b>	1	1	1	1
	<b>Is there more than 1 left-turn lane?</b>	No	No	No	No
<b>Check 4</b>	<b>Is there an exclusive left-turn lane?</b>	No	Yes	Yes	No
	<b>Does the opposite approach meet Check 1, 2, or 3?</b>	No	No	No	No
<b>Result</b>	<b>Protected left-turn phase?</b>	No	No	No	No

Note: NB = northbound, SB = southbound, WB = westbound, EB = eastbound.

**Exhibit 170. Case study 2: lane group determination for Telegraph Avenue/Claremont Avenue.**

	Northbound			Southbound			Westbound			Eastbound		
	L	T	R	L	T	R	L	T	R	L	T	R
<b>Peak hour volume (veh/h)</b>	8	864	170	61	717	69	114	61	77	12	5	5
<b>Number of lanes</b>	2			1	1		1	1		1		
<b>De facto exclusive lane?</b>	No											
<b>Lane group type</b>	Mixed			Ex.	Mixed		Ex.	Mixed		Mixed		

Note: L = left, T = through, R = right, Ex. = Exclusive.

right-turn and left-turn volumes on the approach are small relative to the through volume, so no de facto turn lanes exist and the original assignment of a mixed lane group is retained.

**Step 3: Convert Turning Movements to Passenger Car Equivalents**

This step converts turning movements to through passenger car equivalents, considering the effect of heavy vehicles, variations in traffic flow during the hour, the impact of opposing through vehicles on permitted left-turning vehicles, the impact of pedestrians on right-turning vehicles, lane utilization, and the impact of parking maneuvers on through and right-turning vehicles.

**Step 3a: Heavy Vehicle Adjustment**

The adjustment for heavy vehicles  $E_{HVadj}$  is calculated using Equation 75.

$$E_{HVadj} = 1 + P_{HV}(E_{HV} - 1) = 1 + 0.05(2 - 1) = 1.05$$

**Step 3b: Peak Hour Factor Adjustment**

The adjustment for variation in flow during the peak hour is calculated using Equation 76.

$$E_{PHF} = \frac{1}{PHF} = \frac{1}{0.92} = 1.09$$

**Step 3c: Turn Impedance Adjustment**

The turn impedance adjustment factors  $E_{LT}$  and  $E_{RT}$  adjust for impedances experienced by left- and right-turning vehicles, respectively.

All left turns are permitted movements and therefore the left-turn adjustment factor will take on significantly higher values than in Example 2. Exhibit 62 is used to determine the value for permitted left turns, using the sum of the opposing through and right-turn volumes. For the northbound left turn, the sum of the southbound through and right-turn volumes is 786 veh/h and therefore  $E_{LT} = 3.00$  for the northbound left-turn. Similarly,  $E_{LT}$  values for the southbound, westbound, and eastbound left turns are 5.00, 1.10, and 1.10, respectively.

For permitted right turns (the typical situation), Exhibit 63 is used to determine the value of  $E_{RT}$ . For a “Medium” level of pedestrian activity,  $E_{RT} = 1.30$ .

**Step 3d: Parking Adjustment Factor**

The parking adjustment factor  $E_p$  is determined from Exhibit 64. For exclusive left-turn lanes and all movements on Telegraph Avenue, where no adjacent on-street parking is provided,  $E_p = 1.00$ . For the eastbound and westbound through lane groups on Claremont Avenue, which each have one lane and adjacent parking,  $E_p = 1.20$ .

**Step 3e: Lane Utilization Factor**

The lane utilization factor  $E_{LU}$  is determined from Exhibit 65. For the southbound and westbound exclusive left-turn lanes,  $E_{LU} = 1.00$ , as only one left-turn lane is provided. The northbound approach provides two shared lanes, with  $E_{LU} = 1.05$ . All other movements occur in single shared lanes, with  $E_{LU} = 1.00$ .

**Step 3f: Adjustment Factor for Other Effects**

In the absence of information on other effects,  $E_{\text{other}}$  is set to the default 1.00.

**Step 3g: Through Passenger Car Equivalent Flow Rate**

The through passenger car equivalent flow rate  $v_{adj}$  is calculated using Equation 78. For the southbound left turn, the calculation is as follows:

$$v_{adj,SBLT} = VE_{HVadj}E_{PHF}E_{LT}E_{RT}E_pE_{LU}E_{\text{other}}$$

$$v_{adj,SBLT} = (61)(1.05)(1.09)(5.00)(1.00)(1.00)(1.00)(1.00) = 349 \text{ tpc/h}$$

**Step 3h: Equivalent Per-Lane Flow Rate**

Finally, the equivalent per-lane flow rate  $v_i$  for a given lane group  $i$  is calculated using Equation 79. For the southbound left turn, which operates in a single lane, the calculation is:

$$v_{SBLT} = \frac{v_{adj,SBLT}}{N_{SBLT}} = \frac{349}{1} = 349 \text{ tpc/h/ln}$$

Exhibit 171 shows the computation results for all lane groups.

**Step 4: Calculate Critical Lane Group Volumes****Step 4a: Identify Critical Movements**

When opposing approaches use permitted phasing, as is the case at this intersection, the critical lane volume will be the highest lane volume of all lane groups for a pair of approaches. For the

**Exhibit 171. Case study 2: through passenger car equivalent calculations.**

	Northbound			Southbound			Westbound			Eastbound		
	L	T	R	L	T	R	L	T	R	L	T	R
<b>Movement volume (veh/h)</b>	8	864	170	61	717	69	114	61	77	12	5	5
<b>Heavy vehicle adj., <math>E_{HVadj}</math></b>	1.05	1.05	1.05	1.05	1.05	1.05	1.05	1.05	1.05	1.05	1.05	1.05
<b>PHF adj., <math>E_{PHF}</math></b>	1.09	1.09	1.09	1.09	1.09	1.09	1.09	1.09	1.09	1.09	1.09	1.09
<b>Left-turn impedance adj., <math>E_{LT}</math></b>	3.00	1.00	1.00	5.00	1.00	1.00	1.10	1.00	1.00	1.10	1.00	1.00
<b>Right-turn impedance adj., <math>E_{RT}</math></b>	1.00	1.00	1.30	1.00	1.00	1.30	1.00	1.00	1.30	1.00	1.00	1.30
<b>Parking adj., <math>E_p</math></b>	1.00	1.00	1.00	1.00	1.00	1.00	1.00	1.20	1.20	1.00	1.20	1.20
<b>Lane utilization adj., <math>E_{LU}</math></b>	1.05	1.05	1.05	1.00	1.00	1.00	1.00	1.00	1.00	1.00	1.00	1.00
<b>Other effects adj., <math>E_{other}</math></b>	1.00	1.00	1.00	1.00	1.00	1.00	1.00	1.00	1.00	1.00	1.00	1.00
<b>Equivalent flow rate (tpc/h)</b>	29	1,038	266	349	821	103	144	84	137	15	7	9
<b>Number of lanes</b>	2		1	1			1	1		1		
<b>Lane group type</b>	Mixed		Ex.	Mixed			Ex.	Mixed		Mixed		
<b>Lane group flow rate (tpc/h)</b>	1,333		349	924			144	221		31		
<b>Equivalent flow rate (tpc/h/ln)</b>	667		349	924			144	221		31		

Note: L = left, T = through, R = right, adj. = adjustment, PHF = peak hour factor, Ex. = Exclusive.

east–west approaches, the critical volume  $V_{c,EW}$  is calculated using Equation 82, while the critical volume for the north–south approaches  $V_{c,NS}$  is calculated using Equation 83.

$$V_{c,EW} = \max(V_{EBLT}, V_{EBTH}, V_{EBRT}, V_{WBTL}, V_{WBTH}, V_{WBRT}) = \max(0, 31, 0, 144, 221, 0) = 221 \text{ tpc/h/ln}$$

$$V_{c,NS} = \max(V_{NBLT}, V_{NBTH}, V_{NBRT}, V_{SBLT}, V_{SBTH}, V_{SBR}) = \max(0, 667, 0, 349, 924, 0) = 924 \text{ tpc/h/ln}$$

The critical lane group volumes for the intersection of Telegraph Avenue and Claremont Avenue are southbound through (924 tpc/h/ln) and westbound through (221 tpc/h/ln).

**Step 4b: Calculate the Sum of the Critical Lane Group Volumes**

The sum of the critical lane group volumes is calculated using Equation 87.

$$V_c = v_{c,EW} + v_{c,NS} = 221 + 924 = 1,145 \text{ tpc/h/ln}$$

**Step 5: Compute Intersection Volume-to-Capacity Ratio**

The intersection  $v/c$  ratio is computed using Equation 88. The capacity is assumed to be the default 1,650 tpc/h/ln suggested in Section L4 of the Guide.

$$X_c = \frac{V_c}{c_i} = \frac{1,145}{1,650} = 0.69$$

Applying the guidance provided in Equation 66, it is determined that the intersection will likely operate under capacity with the proposed lane geometry.

**5. Example 4: Estimating Auto and BRT Speeds**

**Approach**

This example determines auto delay, auto travel times, and auto and bus speeds for super-section C along Telegraph Avenue. First, control delay is calculated for the northbound and southbound through movements on Telegraph Avenue at each intersection, following the guidance in Section L5 of the Guide. Next, these control delays are used as inputs to the simplified HCM urban street analysis method described in Section K6 to determine auto speeds and travel

times within each section and for supersection C as a whole. Finally, the transit speed method for urban streets described in Section O4 is used to estimate BRT speeds.

## Signalized Intersection Control Delay

This portion of the example continues the calculations started in Example 3 for the intersection of Telegraph Avenue and Claremont Avenue. Summary results for the other five signalized intersections within supersection C are presented at the end of this step.

### Step 6: Calculate Capacity

#### Step 6a: Calculate Cycle Length

The traffic signal cycle length  $C$  is assumed to be 30 seconds per critical phase, per Equation 89. As permitted left turns are used at the Telegraph Avenue/Claremont Avenue intersection, there are two critical phases, and  $C$  would be calculated as 60 seconds. However, at an intersection with protected left turns on all approaches, such as Telegraph Avenue/51st Street, there would be four critical phases, and  $C$  would be 120 seconds. Similarly, three-legged intersection with a protected left turn on the main street, such as Telegraph Avenue/48th Street, would have three critical phases and  $C$  would be calculated as 90 seconds. As urban street facilities are typically timed to provide a common cycle length at all intersections within the facility, the largest calculated cycle length (120 seconds) will be assumed to be the cycle length used at all intersections along the facility.

#### Step 6b: Calculate the Total Effective Green Time

The total effective green time  $g_{TOT}$  available during the cycle is calculated using Equation 90. In the absence of other information, the default value of 4 seconds per critical phase for lost time per cycle is used. For the Telegraph Avenue/Claremont Avenue intersection,  $g_{TOT}$  is then:

$$g_{TOT} = C - L = 120 - 8 = 112 \text{ s}$$

The total effective green time is then allocated to each critical phase in proportion to the critical lane group volume for that movement using Equation 91. From Example 3, Step 4a, the critical lane group volumes are southbound through (924 tpc/h/ln) and westbound through (221 tpc/h/ln). From Example 3, Step 4b, the critical intersection volume is 1,145 tpc/h/ln. Then:

$$g_{SBTH} = g_{TOT} \left( \frac{V_{CSBTH}}{V_c} \right) = 112 \left( \frac{924}{1,145} \right) = 90.4 \text{ s}$$

$$g_{WBTH} = g_{TOT} \left( \frac{V_{cWBTH}}{V_c} \right) = 112 \left( \frac{221}{1,145} \right) = 21.6 \text{ s}$$

The effective green time for the non-critical phases (and the movements served by those phases) is set equal to the green time for the phase on the opposing approach that serves the same movements. In this case, with only two critical phases, all northbound and southbound movements are initially assigned an effective green time of 90.4 seconds, while all westbound and eastbound movements are initially assigned an effective green time of 21.6 seconds.

The green time for each phase should be reviewed against considerations such as the minimum green time and the time required for pedestrians to cross the approach, as stated in local policy and standards such as the *Manual on Uniform Traffic Control Devices* (FHWA 2009). In this case, on the basis of the length of the Telegraph Avenue crosswalks and local policy on minimum pedestrian Walk time, a minimum of 27.0 seconds for the combined pedestrian Walk and flashing Don't Walk intervals is required to cross Telegraph Avenue, which translates into a minimum effective green time



of 23.0 seconds for the parallel through movements. Therefore, the effective green time assigned to the westbound and eastbound movements is increased to 23.0 seconds and the effective green time assigned to the northbound and southbound movements is decreased to 89.0 seconds.

### Step 6c: Calculate Capacity and Volume-to-Capacity Ratio

The capacity  $c_i$  and volume-to-capacity ratio  $X_i$  for each critical lane group  $i$  are calculated using Equation 92 and Equation 93. As the study area is located in a large metropolitan area with millions of residents, a base saturation flow rate of 1,900 pc/h/ln is used in Equation 92. For the southbound through lane group at Telegraph Avenue and Claremont Avenue, the capacity and  $v/c$  ratio are:

$$c_{SBTH} = \text{BaseSat} \left( \frac{g_{SBTH}}{C} \right) = 1,900 \left( \frac{89.0}{120} \right) = 1,409 \text{ tpc/h/ln}$$

$$X_{SBTH} = \frac{v_{SBTH}}{c_{SBTH}} = \frac{924}{1,409} = 0.66$$

For the westbound through lane group, the capacity and  $v/c$  ratio are:

$$c_{WBTH} = \text{BaseSat} \left( \frac{g_{WBTH}}{C} \right) = 1,900 \left( \frac{23.0}{120} \right) = 364 \text{ tpc/h/ln}$$

$$X_{WBTH} = \frac{v_{WBTH}}{c_{WBTH}} = \frac{221}{364} = 0.61$$

For the intersection as a whole, the critical degree of saturation  $X_c$  is calculated using Equation 94 and Equation 95.

$$c_{SUM} = 1,900 \left( \frac{\sum_{i=1}^n g_i}{C} \right) = 1,900 \left( \frac{89.0 + 23.0}{120} \right) = 1,773 \text{ tpc/h}$$

$$X_c = \frac{\sum_{i=1}^n v_i}{c_{SUM}} = \frac{924 + 221}{1,773} = 0.65$$

The initial finding in Example 3 that this intersection will operate below capacity is confirmed.

### Summary Capacity Results for Supersection C

Exhibit 172 summarizes the results of the capacity calculations for all of the signalized intersections within supersection C. As can be seen from the table, only the Telegraph Avenue/51st Street intersection is expected to operate over capacity.

### Step 7: Estimate Delay

The control delay for  $d_i$  for the northbound and southbound lane groups on Telegraph Avenue is calculated using Equation 96. This equation requires first computing the uniform delay  $d_1$  with Equation 97 and the incremental delay  $d_2$  with Equation 98. There are no unsignalized turning movements at any intersection within supersection C, so unsignalized movement delay  $d_{unsig}$  is zero. The following presents the calculation details for the northbound and southbound through lane groups at the Claremont Avenue intersection; summary results for the northbound and southbound lane groups at all intersections in supersection C follow.

Uniform delay for the southbound through lane group is determined using the southbound movement volume from Step 3 (Exhibit 171) and the critical north–south effective green time

**Exhibit 172. Case study 2: capacity calculations for supersection C.**

	Cross Street					
	45th	48th	49th	51st	Claremont	55th
Number of critical phases	2	3	3	4	2	3
Cycle length, $C$ (s)	120	120	120	120	120	120
Total effective green time, $g_{TOT}$ (s)	112	108	108	104	112	108
Critical EW TH volume, $V_{EWTH,C}$ (tpc/h)	188	77	170	404	221	518
Critical EW LT volume, $V_{EWLT,C}$ (tpc/h)	0	0	0	323	0	0
Critical NS TH volume, $V_{NSTH,C}$ (tpc/h)	759	651	992	862	924	972
Critical NS LT volume, $V_{NSLT,C}$ (tpc/h)	0	125	95	340	0	117
Sum of critical volumes, $V_C$ (tpc/h)	947	853	1,257	1,929	1,145	1,607
Critical EW TH effective green, $g_{EWTH,C}$ (s)	22.2	9.7	14.6	21.8	21.6	34.8
Adj. critical EW TH effective green, $g_{EWTH,C}$ (s)	23.0	23.0	23.0	23.0	23.0	34.8
Critical EW LT effective green, $g_{EWLT,C}$ (s)	0.0	0.0	0.0	17.4	0.0	0.0
Critical NS LT effective green, $g_{NSLT,C}$ (s)	0.0	15.8	8.2	18.3	0.0	7.9
Critical NS TH effective green, $g_{NSTH,C}$ (s)	89.8	82.5	85.2	46.5	90.4	65.3
Adj. critical NS TH effective green, $g_{NSTH,C}$ (s)	89.0	69.2	76.8	45.3	89.0	65.3
Critical EW TH capacity, $c_{EWTH,C}$ (tpc/h)	364	364	364	364	364	551
Critical EW LT capacity, $c_{EWLT,C}$ (tpc/h)				276		
Critical NS TH capacity, $c_{NSTH,C}$ (tpc/h)	1,409	1,096	1,216	717	1,409	1,034
Critical NS LT capacity, $c_{NSLT,C}$ (tpc/h)		250	130	290		125
Intersection capacity, $c_{SUM}$ (tpc/h)	1,773	1,710	1,710	1,647	1,773	1,710
EW TH volume-to-capacity ratio, $X_{EWTH}$	0.52	0.21	0.47	1.11	0.61	0.94
EW LT volume-to-capacity ratio, $X_{EWLT}$				1.17		
NS TH volume-to-capacity ratio, $X_{NSTH}$	0.54	0.59	0.82	1.20	0.66	0.94
NS LT volume-to-capacity ratio, $X_{NSLT}$		0.50	0.73	1.17		0.94
Intersection volume-to-capacity ratio, $X_c$	0.53	0.50	0.74	1.17	0.65	0.94

Note: EW = east–west, NS = north–south, TH = through, LT = left turn, adj. = adjusted.

from Step 6b (Exhibit 172). The volume-to-capacity ratio  $X$  for the southbound direction is  $924 / 1,409 = 0.66$ . The calculation proceeds as follows:

$$d_1 = \frac{0.5C(1 - g/C)^2}{1 - [\min(1, X)(g/C)]} = \frac{(0.5)(120)(1 - 89/120)^2}{1 - [\min(1, [924/1,409])(89/120)]} = 7.8 \text{ s}$$

Incremental delay for the southbound through lane group is calculated as follows:

$$d_2 = 225 \left[ (x - 1) + \sqrt{(x - 1)^2 + \frac{16X}{c}} \right] = 225 \left[ (0.66 - 1) + \sqrt{(0.66 - 1)^2 + \frac{16 \times 0.66}{1,409}} \right] = 2.4 \text{ s}$$

In the absence of other information, average signal progression is assumed, and a value of 1.00 is obtained from Exhibit 68 for the progression factor  $PF$ . The control delay for the southbound lane group is then:

$$d_i = d_1PF + d_2 + d_{insig} = (7.8)(1.00) + 2.4 + 0.0 = 10.2 \text{ s}$$

Similarly, for the northbound lane group, the  $v/c$  ratio is 0.47; the uniform delay is 6.1 s; the incremental delay is 1.1 s; and the control delay is 7.2 s.

The calculations for the other intersections are conducted similarly. However, the 3-leg intersections with protected southbound left turns on Telegraph Avenue (48th and 49th Streets) are an exception to the general rule that non-critical phases (the southbound through in these cases) are assigned the same effective green time as their counterpart critical phase (i.e., the northbound through). As

**Exhibit 173. Case study 2: delay and LOS calculations for supersection C.**

	45th		48th		49th		51st		Claremont		55th	
	NB	SB	NB	SB	NB	SB	NB	SB	NB	SB	NB	SB
Cycle length, $C$ (s)	120	120	120	120	120	120	120	120	120	120	120	120
Effective green time, $g$ (s)	89.0	89.0	69.2	85.0	76.8	85.0	45.3	45.3	89.0	89.0	65.3	65.3
Lane group volume, $V$ (tpc/h/ln)	759	574	651	578	992	699	862	641	667	924	1,028	972
Lane group capacity, $c$ (tpc/h/ln)	1,409	1,409	1,096	1,346	1,216	1,346	717	717	1,409	1,409	1,034	1,034
Volume-to-capacity ratio, $X$	0.54	0.41	0.59	0.43	0.82	0.52	1.20	0.89	0.47	0.66	0.99	0.94
Uniform delay, $d_1$ (s)	6.7	5.8	16.3	7.3	16.4	8.1	37.4	35.0	6.1	7.8	27.0	25.5
Incremental delay, $d_2$ (s)	1.5	0.9	2.3	1	6.3	1.4	103.1	15.5	1.1	2.4	25.7	16.8
Progression quality	Avg.	Avg.	Avg.	Avg.	Avg.	Avg.	Avg.	Avg.	Avg.	Avg.	Avg.	Avg.
Progression factor, $PF$	1.0	1.0	1.0	1.0	1.0	1.0	1.0	1.0	1.0	1.0	1.0	1.0
Control delay, $d$ (s)	8.2	6.7	18.6	8.3	22.7	9.5	140.5	50.5	7.2	10.2	52.7	42.3
LOS	A	A	B	A	C	A	F	D	A	B	D	D

Note: Avg. = average.

there is no northbound left turn at these intersections, the southbound through movement can also move while the southbound left turn is being served; therefore, the effective green time used for the southbound through is the sum of the southbound left turn and northbound through effective green.

Exhibit 173 provides the northbound and southbound delay calculation results for all signalized intersections in supersection C.

### Step 8: Level of Service

Comparing the calculated control delays from Step 7 to the values given in Exhibit 69, it is found that the northbound through movement would operate at LOS A, while the southbound through movement would operate at LOS B. Exhibit 173 provides the northbound and southbound LOS results for all signalized intersections in supersection C. It can be seen that through movements on Telegraph Avenue will operate at LOS D or better at all intersections following implementation of BRT, except at 51st Street, where the northbound direction will operate at LOS F. In addition, the northbound movement at 55th Street will operate close to capacity.

### Section Travel Times and Speeds (Auto)

This portion of the example presents the speed and travel time calculations for automobiles on northbound Telegraph Avenue between 45th and 48th Streets. Summary results for both directions of Telegraph Avenue through supersection C follow.

#### Step 1: Calculate Running Time

The running time  $t_R$  for the section is calculated using Equation 58. From Example 1, the posted speed in supersection C is 30 mph. The default user-selected adjustment to the posted speed is 5 mph. The segment length is 655 feet. Then:

$$t_R = \frac{3,600 \times L}{5,280 \times (S_{pl} + UserAdj)} = \frac{3,600 \times 655}{5,280 \times (30 + 5)} = 12.8 \text{ s}$$

#### Steps 2–4: Calculate the Downstream Intersection Capacity, Volume-to-Capacity Ratio, and Delay

These steps were completed previously as part of the signalized intersection calculations described above. From Exhibit 173, the control delay  $d$  in the northbound direction is 18.6 seconds.

### Step 5: Compute the Average Travel Speed and Determine Level of Service

The average travel time on the segment  $T_T$  is calculated using Equation 64:

$$T_T = t_R + d = 12.8 + 18.6 = 31.4 \text{ s}$$

The average travel speed on the segment  $S_{T,seg}$  is calculated using Equation 65:

$$S_{T,seg} = \frac{3,600 \times L}{5,280 \times T_T} = \frac{3,600 \times 655}{5,280 \times 31.4} = 14.2 \text{ mph}$$

From Exhibit 52, this speed corresponds to LOS D.

### Summary Speed Results for Supersection C

Travel times, speed, and LOS results by section are presented in Exhibit 174 and Exhibit 175 for the northbound and southbound directions, respectively.

For the northbound direction of supersection C, the average travel time is 293.7 seconds, the average speed is 6.2 mph, and the LOS is F. In the southbound direction, the average travel time is 137.2 seconds, the average speed is 13.3 mph, and the LOS is E.

### Section Travel Speeds (BRT)

The BRT project includes exclusive bus-only lanes between traffic signals, with right-turning traffic allowed into the bus lanes at traffic signals. There will only be one BRT stop within

**Exhibit 174. Case study 2: travel time, speed, and LOS calculations for supersection C (northbound).**

	Downstream Intersection				
	48th	49th	51st	Claremont	55th
Speed limit, $S_{pl}$ (mph)	30	30	30	30	30
User adjustment, $UserAdj$ (mph)	5	5	5	5	5
Segment length, $L$ (ft)	655	468	478	269	798
Running time, $t_R$ (s)	12.8	9.1	9.3	5.2	15.6
Control delay, $d$ (s)	18.6	22.7	140.5	7.2	52.7
Volume-to-capacity ratio, $X$	0.59	0.82	1.20	0.47	0.99
Segment travel time, $T_t$ (s)	31.4	31.8	149.8	12.4	68.3
Segment speed, $S_{T,seg}$	14.2	10.0	2.2	14.8	8.0
LOS	D	F	F	D	F

**Exhibit 175. Case study 2: travel time, speed, and LOS calculations for supersection C (southbound).**

	Downstream Intersection				
	45th	48th	49th	51st	Claremont
Speed limit, $S_{pl}$ (mph)	30	30	30	30	30
User adjustment, $UserAdj$ (mph)	5	5	5	5	5
Segment length, $L$ (ft)	655	468	478	269	798
Running time, $t_R$ (s)	12.8	9.1	9.3	5.2	15.6
Control delay, $d$ (s)	6.7	8.3	9.5	50.5	10.2
Volume-to-capacity ratio, $X$	0.41	0.43	0.52	0.89	0.66
Segment travel time, $T_t$ (s)	19.5	17.4	18.8	55.7	25.8
Segment speed, $S_{T,seg}$	22.9	18.3	17.3	3.3	21.1
LOS	C	C	D	F	C

supersection C, at 49th Street. Section O4 of the Guide provides two options for estimating bus speeds: (1) a generalized method and (2) a modified version of the auto method that was used above. Because Option 2 only applies to buses running in mixed traffic, and not to buses running in exclusive lanes, Option 1 will be followed.

### Step 1: Unimpeded Bus Travel Time Rate

This step calculates the bus' speed without traffic signal delays, but including deceleration, dwell time, and acceleration delays due to bus stops. The process uses Equation 152 through Equation 157. First, the time for a bus to decelerate from its running speed to a stop  $t_{dec}$  is calculated from Equation 157, assuming a running speed between stops equal to the posted speed (30 mph) and the default bus deceleration rate of 4.0 feet per second per second from Exhibit 104:

$$t_{dec} = \frac{1.47v_{run}}{d} = \frac{1.47 \times 30}{4.0} = 11.0 \text{ s}$$

Second, the time for a bus to accelerate back to its running speed  $t_{acc}$  is calculated from Equation 156 in a similar manner, but using the default bus acceleration rate of 3.4 feet per second per second from Exhibit 104.

$$t_{acc} = \frac{1.47v_{run}}{a} = \frac{1.47 \times 30}{3.4} = 13.0 \text{ s}$$

Third, the distance traveled during acceleration and deceleration associated with each bus stop  $L_{ad}$  is calculated using Equation 155.

$$L_{ad} = 0.5at_{acc}^2 + 0.5dt_{dec}^2 = [0.5 \times 3.4 \times (13.0)^2] + [0.5 \times 4.0 \times (11.0)^2] = 529 \text{ ft}$$

Fourth, the portion of each mile of route traveled at running speed  $L_{rs}$  is calculated from Equation 154. This equation uses the average bus stop spacing to determine how often a bus must accelerate or decelerate to serve a stop. In this case, there is one stop within supersection C and the next-closest bus stops are at 40th and 59th Streets, giving an average stop spacing of 2,900 feet (1.82 stops per mile). Then:

$$L_{rs} = 5,280 - N_s L_{ad} = 5,280 - (1.82 \times 529) = 4,317 \text{ ft}$$

Fifth, the time spent per mile traveling at running speed  $t_{rs}$  is determined from Equation 153:

$$t_{rs} = \frac{L_{rs}}{1.47v_{run}} = \frac{4,317}{1.47 \times 30} = 97.9 \text{ s}$$

Finally, the unimpeded running time rate  $t_u$  is determined from Equation 152, applying the default average critical stop dwell time of 30 seconds for urban areas from Exhibit 104. (The critical stop dwell time is used as this is the only BRT stop within supersection C.)

$$t_u = \frac{t_{rs} + N_s(t_{dt} + t_{acc} + t_{dec})}{60} = \frac{97.9 + 1.82(30 + 13.0 + 11.0)}{60} = 3.3 \text{ min/mi}$$

### Step 2: Additional Bus Travel Time Delays

This step estimates additional bus dwell time delays  $t_l$  in the exclusive bus lane due to traffic signal and traffic interference, using Exhibit 109. As supersection C is not located within Oakland's central business district, the "Arterial Roadways Outside the CBD" portion of the exhibit is used, and a value of 0.7 minutes per mile is identified for bus lanes.

### Step 3: Base Bus Speed

The two running time rates calculated in Steps 1 and 2 are combined into a base bus running time rate  $t_r$  using Equation 160 and a base bus speed  $S_b$  using Equation 161.

$$t_r = t_u + t_l = 3.3 + 0.7 = 4.0 \text{ min/mi}$$

$$S_b = \frac{60}{t_r} = \frac{60}{4.0} = 15 \text{ mph}$$

This estimated base bus speed applies to both directions, northbound and southbound, as all the inputs used to calculate it are the same in both directions.

### Step 4: Average Bus Speed

The bus rapid transit line is projected to operate initially at 12-minute headways (i.e., 5 buses per hour per direction). In addition, a local version of the route that stops more frequently will operate in the bus lanes at 15-minute headways (i.e., 4 buses per hour per direction). The total number of buses is 9 per hour. From the discussion of Step 4 in Section O4 of the Guide, bus congestion at bus stops typically only affects bus speeds when more than 10–15 buses per hour are scheduled. As the number of scheduled buses is 9 per hour is less than the 10–15 per hour threshold, the bus–bus interference factor  $f_{bb}$  is set to 1.00, and the estimated average bus speed equals the base bus speed, namely 15 mph.

### Interpretation of Speed Results

The low auto speed of 6 mph in the northbound direction of Telegraph Avenue is a result of congestion in the sections ending at 49th, 51st, and 55th Streets. The southbound speed of 13 mph is better, but still affected by congestion in the section ending at 51st Street. Average BRT speeds of 15 mph in each direction demonstrate the combined benefit of the exclusive bus lane and the long stop spacing, particularly in the northbound (peak) direction.

## 6. Example 5: Predicting Queue Hot Spots

### Approach

This short example demonstrates the estimation of queue lengths for the northbound and southbound through movements on Telegraph Avenue in supersection C, following Step 9 of the simplified signalized intersection method described in Section L5 of the Guide.

### Calculation

The deterministic average queue for each lane group  $Q$  is determined by dividing the average uniform delay for that lane group by the capacity for that lane group, using Equation 99. This equation uses the uniform delay  $d_1$  for the lane group and the per-lane capacity of the lane group  $c$ , both of which were computed as part of Example 4 and presented in Exhibit 173.

Note that this estimate provides the average queue at the end of red, and is only applicable to lane groups that operate under capacity. For limited storage situations (such for left turn bays or short block lengths), it is desirable to provide storage for random fluctuations in-vehicle arrivals from cycle to cycle. In such a case, a 95th percentile probable queue may be used, estimated as twice the average queue. Results should be rounded to whole vehicles.

**Exhibit 176. Case study 2: deterministic average queues in supersection C.**

	45th		48th		49th		51st		Claremont		55th	
	NB	SB	NB	SB	NB	SB	NB	SB	NB	SB	NB	SB
Lane group capacity, <i>c</i> (tpc/h/ln)	1,409	1,409	1,096	1,346	1,216	1,346	717	717	1,409	1,409	1,034	1,034
Volume-to-capacity ratio, <i>X</i>	0.54	0.41	0.59	0.43	0.82	0.52	1.20	0.89	0.47	0.66	0.99	0.94
Uniform delay, <i>d<sub>1</sub></i> (s)	6.7	5.8	16.3	7.3	16.4	8.1	37.4	35.0	6.1	7.8	27.0	25.5
Deterministic avg. queue (tpc/ln)	3	2	5	3	6	3	**	7	2	3	8	7
95th percentile queue (tpc/ln)	5	4	10	5	11	6	**	14	5	6	16	15

Note: Avg. = average.

\*\*Cannot be calculated, *v/c* ratio > 1.

For northbound Telegraph Avenue at 55th Street, the average queue computation is as follows:

$$Q = \frac{d_1 \times c}{3,600} = \frac{27.0 \times 1,034}{3,600} = 7.8 \rightarrow 8 \text{ tpc/ln}$$

The estimated 95th percentile queue would be  $2 \times 7.8 = 15.6$  tpc/ln, which rounds to 16 tpc/ln. Exhibit 176 summarizes the results for both directions of Telegraph Avenue in supersection C.

At an average length of 25 feet per vehicle, the 95th-percentile southbound queue approaching 51st Street would be 350 feet and would exceed the 269-foot spacing between the signalized intersections. At 55th Street, the 95th-percentile queue lengths are estimated to be up to 400 feet long, which might require checking for potential blockage issues. The northbound queue at 51st Street cannot be calculated, as this movement operates over capacity; however, it can be determined from Exhibit 173 that the unserved demand at the end of the p.m. peak hour would be 145 tpc/ln (i.e., the difference between the movement demand and the movement capacity).

## 7. Example 6: Pedestrian, Bicycle, and Transit LOS

### Approach

This example demonstrates the computation of pedestrian, bicycle, and transit LOS for supersection C, following the methods presented in Section O4 of the Guide for urban streets. The BRT project will convert one of the two travel lanes in each direction, plus the parking lane, into an exclusive bus lane and bicycle lane. The remaining width will be added to the sidewalk area and, in most sections, will be used to create an improved landscape buffer area.

Link LOS (i.e., between traffic signals) will be calculated for the pedestrian and bicycle modes, to reduce the computational effort while providing a reasonable proxy for a section-level analysis. As pedestrian volumes were determined to be “Medium” in previous examples, an evaluation of pedestrian density (i.e., sidewalk crowding) will not be performed. Section and facility LOS will be calculated for the transit mode. Detailed calculations will be presented for the northbound direction of Telegraph Avenue (including the adjacent sidewalk) between 45th and 48th Streets. Summary results will then be presented for both directions of Telegraph Avenue for all sections of supersection C.

### Pedestrian LOS

#### Input Data

Exhibit 98 lists the input data requirements for calculating pedestrian LOS. For a link-level analysis, only the number of through travel lanes for motorized vehicles and the directional vehicular volume are required, both of which are available from previous examples in this case

study. (Pedestrian signal delay data shown in Exhibit 98 are only required for a section-level analysis, and the segment length is only required for a facility-level analysis.) All other inputs can be defaulted, but will be substituted with actual values when known.

Actual values are known or planned as part of the BRT project for the following inputs:

- Sidewalk width by section;
- Street tree presence by section;
- Landscape buffer width by section;
- On-street parking (none);
- Outside travel lane width (12 feet); and
- Bicycle lane width (5 feet).

### Calculation

The pedestrian LOS score is calculated using Equation 148. It takes the following input values:

- The distance from the inner edge of the outside lane to the curb  $W_T$  is illustrated in Exhibit 99. In this case, it is equal to the bus lane width (12 feet) plus the bicycle lane width (5 feet), for a total of 17 feet in all sections.
- The distance from the outer edge of the outside lane to the curb  $W_1$  is illustrated in Exhibit 99. In this case, it is equal to the bicycle lane width (5 feet) in all sections.
- The on-street parking coefficient  $f_p$  is always 0.50.
- The percentage of the section with occupied on-street parking %OSP is zero in all sections, as on-street parking is prohibited in all sections.
- The buffer area coefficient  $f_B$  is 5.37 for the section between 45th and 48th Streets, as street trees will be provided within this section's landscape buffer.
- The landscape buffer width  $W_B$  in the section between 45th and 48th Streets will be 5 feet.
- The actual sidewalk width in the section between 45th and 48th Streets will be 12 feet, but the sidewalk width value  $W_s$  is capped at 10 feet.
- The sidewalk presence coefficient  $f_{sw}$  equals  $6 - 0.3W_s$ , which results in a value of 5.7.
- Traffic volumes are normally assumed to be evenly distributed between the available travel lanes, and the calculation normally divides the directional traffic volume by the number of travel lanes. However, because the travel lane closest to the curb will be used as an exclusive bus lane, the total bus volume (9 buses per hour) will be used for  $V$  and the number of bus lanes (1) will be used for  $N$ .
- As the volume in the exclusive bus lane is less than or equal to 160 vehicles per hour, the low-volume factor  $f_{LV}$  is calculated as  $2.00 - 0.005V$ , which results in a value of 1.96.
- The average vehicle speed between intersections is assumed to be the bus running speed determined in Example 4, 30 mph.

Pedestrian LOS for the northbound section between 45th and 48th Streets is then calculated as follows:

$$PLOS = -1.2276 \times \ln([f_{LV} \times W_T] + [0.5 \times W_1] + [0.5 \times \%OSP] + [f_B \times W_B] + [f_{sw} \times W_s]) + \frac{0.0091V}{4N} + (0.0004 \times SPD^2) + 6.0468$$

$$PLOS = -1.2276 \times \ln([1.96 \times 17] + [0.5 \times 5] + [0.5 \times 0] + [5.37 \times 5] + [3 \times 10]) + \frac{0.0091 \times 9}{4 \times 1} + (0.0004 \times 35^2) + 6.0468$$

$$PLOS = 0.87$$

From Exhibit 100, this PLOS score produces pedestrian LOS A.



### Summary Pedestrian LOS Results for Supersection C (Northbound)

Exhibit 177 presents the summary results for each northbound section in supersection C, following implementation of the BRT project. As can be seen, all sections will operate at pedestrian LOS A, a result of the exclusive bus lane producing low traffic volumes in the travel lane closest to the curb and therefore a wide separation between pedestrians and traffic.

For comparison, Exhibit 178 presents the summary results for the “before” condition. The following changes are made to the inputs:

- With both travel lanes available to general traffic, the normal process described in Section O4 of the Guide is used to determine the directional volume  $V$  and the number of lanes  $N$ . The average of the directional volume departing one intersection and the volume arriving at the next downstream intersection, from Exhibit 165, is used to determine  $V$ .
- Lane widths, landscape buffer widths, and street tree presence take on their existing conditions values.
- A default value of 50% is assumed for occupied on-street parking, except in the section between 51st and Claremont, where on-street parking is prohibited.
- The vehicular free-flow speed of 35 mph used in previous examples is used for the vehicle running speed.

It can be seen that in the “before” condition, pedestrian LOS was in the B to C range. Therefore, it is concluded that the proposed project will result in an improvement in pedestrian LOS.

## Bicycle LOS

### Input Data

Exhibit 101 lists the input data requirements for calculating bicycle LOS. For a link-level analysis, only the number of through travel lanes for motorized vehicles and the directional vehicular volume are required, both of which are available from previous examples in this case study. (Inter-

**Exhibit 177. Case study 2: pedestrian LOS calculations for supersection C (northbound with BRT).**

	Downstream Intersection				
	48th	49th	51st	Claremont	55th
Outside lane volume, $V$ (veh/h)	9	9	9	9	9
Low-volume factor, $f_{LV}$	1.96	1.96	1.96	1.96	1.96
Outside lane width (ft)	12	12	12	12	12
Bicycle lane width (ft)	5	5	5	5	5
Parking lane width (ft)	0	0	0	0	0
Width $W_T$ (ft)	17	17	17	17	17
Width $W_1$ (ft)	5	5	5	5	5
Occupied on-street parking (%)	0	0	0	0	0
Street tree presence	Yes	Yes	No	Yes	Yes
Buffer area coefficient, $f_B$	5.37	5.37	1.00	5.37	5.37
Buffer width, $W_B$ (ft)	5	5	5	5	5
Sidewalk width (ft)	12	8	8	5	5
Width $W_S$ (ft)	10	8	8	5	5
Sidewalk width coefficient, $f_{SW}$	3.0	3.6	3.6	4.5	4.5
Number of bus lanes, $N$	1	1	1	1	1
Bus running speed, $SPD$ (mph)	30	30	30	30	30
PLOS score	0.87	0.88	1.22	0.97	0.97
LOS	A	A	A	A	A

**Exhibit 178. Case study 2: pedestrian LOS calculations for supersection C (northbound “before”).**

	Downstream Intersection				
	48th	49th	51st	Claremont	55th
Directional volume, $V$ (veh/h)	653	706	809	1,044	978
Low-volume factor, $f_{LV}$	1.00	1.00	1.00	1.00	1.00
Outside lane width (ft)	12	12	12	20	12
Bicycle lane width (ft)	0	0	0	0	0
Parking lane width (ft)	8	8	8	0	8
Width $W_T$ (ft)	20	20	20	20	20
Width $W_1$ (ft)	8	8	8	0	8
Occupied on-street parking (%)	50	50	50	0	50
Street tree presence	No	No	No	No	No
Buffer area coefficient, $f_B$	1.00	1.00	1.00	1.00	1.00
Buffer width, $W_B$ (ft)	0	0	0	0	0
Sidewalk width (ft)	14	10	10	7	7
Width $W_S$ (ft)	10	10	10	7	7
Sidewalk width coefficient, $f_{SW}$	3.0	3.0	3.0	3.9	3.9
Number of lanes, $N$	2	2	2	2	2
Bus running speed, $SPD$ (mph)	35	35	35	35	35
PLOS score	1.92	1.98	2.09	2.99	2.33
LOS	B	B	B	C	B

section related inputs shown in Exhibit 101 are only required for a section-level analysis, and the segment length is only required for a facility-level analysis.) All other inputs can be defaulted, but will be substituted with actual values when known.

Actual values are known or planned as part of the BRT project for the following inputs:

- Bicycle lane width (5 feet),
- Outside travel lane width (12 feet),
- On-street parking (none),
- Curb presence (yes),
- Median type (undivided), and
- Percent heavy vehicles (5%, from Example 2).

Default values will be used for the following inputs:

- Curb and gutter width (1.5 feet),
- Pavement condition rating (3.5), and
- Motorized vehicle running speed (the bus running speed of 30 mph from Example 4).

**Calculation**

The bicycle LOS score is calculated using Equation 149. It takes the following input values:

- Traffic volumes are normally assumed to be evenly distributed between the available travel lanes and the calculation normally divides the directional traffic volume by the number of travel lanes. However, because the travel lane closest to the curb will be used as an exclusive bus lane, the total bus volume (9 buses per hour) will be used for  $V$  and the number of bus lanes (1) will be used for  $N$ .
- The average motorized vehicle running speed  $S$  (30 mph for buses in the exclusive lane).
- The effective speed factor  $f_s$  equals  $(1.1199 \times \ln[S - 20]) + 0.8103$ , which results in a value of 3.39.

- The percentage of heavy vehicles  $HV$  in the direction of travel is 5%. Because the bicycle LOS score is highly sensitive to  $HV$ , the percentage of heavy vehicles in the exclusive bus lane (100%, capped at 50% by the methodology) is not used, as it produces unrealistic results.
- The pavement condition rating  $PC$  will use the default value of 3.5.
- There is no on-street parking allowed.
- The width of the outside lane, bicycle lane, and parking lane or shoulder  $W_t$  is illustrated in Exhibit 102. In this case, it is equal to the bus lane width (12 feet) plus the bicycle lane width (5 feet), for a total of 17 feet in all sections.
- The width of the bicycle lane and parking lane or shoulder  $W_l$  is illustrated in Exhibit 102. In this case, it is equal to the bicycle lane width (5 feet) in all sections.
- The effective width of the outside through lane as a function of traffic volume  $W_v$  equals  $W_t \times (2 - 0.005V) = 33.2$  feet as the street is undivided and the bus lane volume is under 160 vehicles per hour.
- The average effective width of the outside through lane  $W_e$  is  $W_v + W_l - (0.2 \times \%OSP) = 38.2$  feet as  $W_t \geq 4$ .

Bicycle LOS for the northbound section between 45th and 48th Streets is then calculated as follows:

$$BLOS = 0.507 \times \ln\left(\frac{V}{4N}\right) + (0.199 \times f_s \times [1 + 0.1038HV]^2) + \left(7.066 \times \left[\frac{1}{PC}\right]^2\right) - (0.005 \times W_e^2) + 0.760$$

$$BLOS = 0.507 \times \ln\left(\frac{9}{4 \times 1}\right) + (0.199 \times 3.39 \times [1 + 0.1038 \times 5]^2) + \left(7.066 \times \left[\frac{1}{3.5}\right]^2\right) - (0.005 \times 38.2^2) + 0.760$$

$$BLOS = -4.01$$

From Exhibit 103, this BLOS score produces bicycle LOS A.

### *Summary Bicycle LOS Results for Supersection C (Northbound)*

Exhibit 179 presents the summary results for each northbound section in supersection C, following implementation of the BRT project. As can be seen, all sections will operate at bicycle LOS A, a result of a combination of the provision of the bicycle lane and the exclusive bus lane acting as an additional buffer between bicyclists and the majority of the traffic.

For comparison, Exhibit 180 presents the summary results for the “before” condition. The following changes are made to the inputs:

- With both travel lanes available to general traffic, the normal process described in Section O4 of the Guide is used to determine the directional volume  $V$  and the number of lanes  $N$ . The average of the directional volume departing one intersection and the volume arriving at the next downstream intersection, from Exhibit 165, is used to determine  $V$ .
- Lane widths take on their existing conditions values.
- A default value of 50% is assumed for occupied on-street parking, except in the section between 51st and Claremont, where on-street parking is prohibited.
- The vehicular free-flow speed of 35 mph used in previous examples is used for the vehicle running speed.

It can be seen that in the “before” condition, bicycle LOS was mostly LOS E, with one section with LOS D. The poor LOS is a result of bicycles having to operate in mixed traffic adjacent

**Exhibit 179. Case study 2: bicycle LOS calculations for supersection C (northbound with BRT).**

	Downstream Intersection				
	48th	49th	51st	Claremont	55th
Outside lane volume, $V$ (veh/h)	9	9	9	9	9
Number of bus lanes, $N$	1	1	1	1	1
Bus running speed, $S$ (mph)	30	30	30	30	30
Speed factor, $f_s$	3.39	3.39	3.39	3.39	3.39
Percent heavy vehicles (%)	5	5	5	5	5
Pavement condition rating	3.5	3.5	3.5	3.5	3.5
Occupied on-street parking (%)	0	0	0	0	0
Outside lane width (ft)	12	12	12	12	12
Bicycle lane width (ft)	5	5	5	5	5
Parking lane width (ft)	0	0	0	0	0
Width $W_i$ (ft)	17	17	17	17	17
Width $W_l$ (ft)	5	5	5	5	5
Width $W_v$ (ft)	33.2	33.2	33.2	33.2	33.2
Effective width $W_e$ (ft)	38.2	38.2	38.2	38.2	38.2
BLOS score	-4.01	-4.01	-4.01	-4.01	-4.01
LOS	A	A	A	A	A

to parked cars. Therefore, it is concluded that the proposed project will result in substantial improvement to bicycle LOS.

### Transit LOS

#### Input Data

Exhibit 104 lists the input data requirements for calculating transit LOS. The key required inputs are bus frequency, average bus speeds, and average passenger load factor; other inputs can be defaulted if not known. Bus frequency was identified in Example 4 (5 BRT buses per hour and

**Exhibit 180. Case study 2: bicycle LOS calculations for supersection C (northbound “before”).**

	Downstream Intersection				
	48th	49th	51st	Claremont	55th
Directional volume, $V$ (veh/h)	653	706	809	1,044	978
Number of lanes, $N$	2	2	2	2	2
Vehicle running speed, $S$ (mph)	35	35	35	35	35
Speed factor, $f_s$	3.84	3.84	3.84	3.84	3.84
Percent heavy vehicles (%)	5	5	5	5	5
Pavement condition rating	3.5	3.5	3.5	3.5	3.5
Occupied on-street parking (%)	50	50	50	0	50
Outside lane width (ft)	12	12	12	20	12
Bicycle lane width (ft)	0	0	0	0	0
Parking lane width (ft)	8	8	8	0	8
Width $W_i$ (ft)	12	12	12	20	12
Width $W_l$ (ft)	0	0	0	0	0
Width $W_v$ (ft)	12.0	12.0	12.0	20.0	12.0
Effective width $W_e$ (ft)	7.0	7.0	7.0	20.0	7.0
BLOS score	5.09	5.13	5.20	3.57	5.29
LOS	E	E	E	D	E

4 local buses per hour). Average BRT bus speed was determined in Example 4, but will need to be determined for local buses. Average passenger load factor will need to be estimated for future conditions. Ridership modeling conducted for the BRT project indicates that the average BRT load factor will be 110% in supersection C, while the average local bus load factor will be 70%.

Other input data values are as follows:

- Average excess wait time (default value of 3 minutes),
- Stops with shelter and bench (only in the 48th to 51st section for both BRT and local),
- Average passenger trip length (default value of 3.7 miles), and
- Pedestrian LOS score by segment (calculated previously in Example 6).

### Local Bus Speed

Local buses will use the exclusive bus lanes, but will stop more frequently than BRT buses (i.e., at every signalized intersection), with an average stop spacing of 535 feet (10 stops per mile). The local bus speed calculation then proceeds similarly to that demonstrated in Example 4 for BRT buses.

**Step 1: Unimpeded Bus Travel Time Rate.** The time for a bus to decelerate from its running speed to a stop  $t_{dec}$  (11.0 s) and accelerate to its running speed from a stop time  $t_{acc}$  (13.0 s), and the distance traveled while accelerating and decelerating (529 ft) are the same as for BRT buses. At 10 stops per mile, the distance traveled at running speed per mile is:

$$L_{rs} = 5,280 - N_s L_{ad} = 5,280 - (10 \times 529) \approx 0 \text{ ft}$$

indicating that buses will rarely be able to accelerate to running speed before starting to decelerate to their next stop. The time spent at running speed per mile  $t_{rs}$  is also 0.

Finally, the unimpeded running time rate  $t_u$  is determined from Exhibit 152, applying the default average dwell time of 20 seconds for urban areas from Exhibit 104. (In contrast to the BRT route, which used the critical stop dwell time, the average dwell time is used here as the local route makes multiple stops within the supersection.)

$$t_u = \frac{t_{rs} + N_s (t_{dt} + t_{acc} + t_{dec})}{60} = \frac{0 + 10(20 + 13.0 + 11.0)}{60} = 7.3 \text{ min/mi}$$

**Step 2: Additional Bus Travel Time Delays.** Local buses using the exclusive bus lane will experience the same additional bus travel time delay  $t_i$  as BRT buses. From Example 4, this value is 0.7 minutes per mile.

**Step 3: Base Bus Speed.** The base bus running time rate  $t_r$  is the sum of the unimpeded travel time rate and the additional travel time delay rate, or 8.0 minutes per mile. The corresponding speed is 7.5 mph.

**Step 4: Average Bus Speed.** As discussed in Example 4, the scheduled number of buses is low enough that bus–bus interference will be rare and the average local bus speed is therefore the same as the base bus speed, or 7.5 mph.

### Transit LOS Calculation

The transit LOS score for a section is a function of the section's transit wait–ride score and its pedestrian LOS score. The transit wait–ride score, in turn, is a function of a headway factor and a perceived travel time factor.

**Headway Factor.** Equation 169 is used to calculate the headway factor. For sections with only local bus service, buses arrive every 15 minutes (i.e., 60 minutes divided by 4 buses per hour), and the headway factor for these sections is:

$$f_h = 4 \times \exp(-0.0239 \times 15) = 2.79$$

Similarly, for the sections with both local and BRT service, buses arrive every 6.7 minutes on average and the headway factor is 3.41.

**Perceived Travel Time Factor.** The perceived travel time factor is calculated using Equation 170. First, an in-vehicle travel time rate (*IVTTR*) is calculated. Equation 172 could be used with average bus speed as an input, but these speeds have already been calculated above (for local bus service, 8.0 minutes per mile) and in Example 4 (for BRT service, 4.0 minutes per mile).

Next, a perceived travel time rate *PTTR* is calculated, which combines the perceived travel time rates of waiting for the bus to come (incorporating the effects of both stop amenities and late buses) and the perceived travel time rate while traveling on the bus. For local bus service, the following inputs are provided to Equation 171 in calculating the perceived travel time rate:

- The travel time perception coefficient for passenger load  $a_1$  is 1.00, as the average local bus load factor was given as 70%.
- The in-vehicle travel time rate *IVTTR* was determined previously to be 8.0 minutes per mile.
- The travel time perception coefficient for excess wait time  $a_2$  uses the default value of 2.0.
- The excess wait time rate *EWTR* is the excess wait time (3 minutes) divided by the average passenger trip length (3.7 miles), which equals 0.8 minutes per mile.
- The amenity time rate *ATR* is 0.4 minutes per mile for stops with a shelter and bench and 0.0 otherwise.

For local bus service in the section between 48th and 51st Street (e.g., the section providing a bus stop with a shelter and bench), *PTTR* is then:

$$PTTR = (a_1 \times IVTTR) + (a_2 \times EWTR) - ATR = (1.00 \times 8.0) + (2.0 \times 0.8) - 0.4 = 9.2 \text{ min/mi}$$

In the other sections without shelters or benches, local bus *PTTR* is 9.6 minutes per mile.

BRT *PTTR* is calculated similarly, except that coefficient  $a_1 = 1.28$  by interpolation, using a 110% load factor and *IVTTR* = 4.0 minutes per mile. The resulting *PTTR* value is 6.3 minutes per mile.

Finally, Equation 170 can now be used to calculate the perceived travel time factor  $f_{PTT}$ . In addition to the *PTTR* value just calculated, this equation uses a default ridership elasticity  $e$  value of  $-0.4$  and a baseline travel time rate of 4.0 minutes per mile (as supersection C is not located within the central business district of a metropolitan area of 5 million population or greater). For BRT service,  $f_{PTT}$  is:

$$f_{PTT} = \frac{[(e-1)BTTR - (e+1)PTTR]}{[(e-1)PTTR - (e+1)BTTR]} = \frac{[(-0.4-1)(4) - (-0.4+1)(6.3)]}{[(-0.4-1)(6.3) - (-0.4+1)(4)]} = 0.84$$

Similarly,  $f_{PTT}$  for local bus service is 0.73 for the section with a shelter and bench at the bus stop and 0.72 elsewhere.

In the section between 48th and 51st Street, which is served by both local and BRT buses, an average  $f_{PTT}$  needs to be calculated, weighted by the number of buses on each route:

$$f_{PTT} = \frac{(0.84)(5 \text{ buses}) + (0.73)(4 \text{ buses})}{9 \text{ buses}} = 0.79$$

**Exhibit 181. Case study 2: transit LOS calculations for supersection C (northbound with BRT).**

	Downstream Intersection				
	48th	49th	51st	Claremont	55th
Bus frequency (bus/h)	4	4	9	4	4
Shelter at stop?	No	No	Yes	No	No
Bench at stop?	No	No	Yes	No	No
Headway factor, $f_h$	2.79	2.79	3.41	2.79	2.79
Perceived travel time factor, $f_{ptt}$	0.72	0.72	0.79	0.72	0.72
Transit wait-ride score, $f_s$	2.01	2.01	2.69	2.01	2.01
Pedestrian LOS score, $PLOS$	0.87	0.88	1.22	0.97	0.97
TLOS score	3.12	3.12	2.15	3.13	3.13
LOS	C	C	B	C	C

In the other sections, served only by local buses at stops without shelters or benches, the  $f_{PTT}$  is 0.72.

**Transit Wait-Ride Score.** The transit wait-ride score  $s_{w-r}$  is calculated by Equation 168. For the section between 48th and 51st Streets, it is:

$$s_{w-r} = f_h \times f_{ptt} = 3.41 \times 0.79 = 2.69$$

For the other sections, it is:

$$s_{w-r} = f_h \times f_{ptt} = 2.79 \times 0.72 = 2.01$$

**Transit LOS Score.** The transit LOS score  $TLOS$  is given by Equation 167, using a section's wait-ride score and pedestrian LOS score as inputs. For the section between 48th and 51st Street, it is:

$$TLOS = 6.0 - (1.50 \times s_{w-r}) + (0.15 \times PLOS) = 6.0 - (1.50 \times 2.69) + (0.15 \times 1.22) = 2.15$$

From Exhibit 111, this corresponds to transit LOS B. Exhibit 181 summarizes the results for all sections in the northbound direction.

As can be seen, the section served by a BRT stop provides transit LOS B and is close to the LOS A threshold. The other sections served only by local buses provide transit LOS C.

For comparison, Exhibit 182 presents the summary results for the “before” condition. The following changes are made to the inputs:

**Exhibit 182. Case study 2: transit LOS calculations for supersection C (northbound “before”).**

	Downstream Intersection				
	48th	49th	51st	Claremont	55th
Bus frequency (bus/h)	6	6	6	6	6
Shelter at stop?	No	No	Yes	No	No
Bench at stop?	No	No	Yes	No	No
Headway factor, $f_h$	3.15	3.15	3.15	3.15	3.15
Perceived travel time factor, $f_{ptt}$	0.62	0.62	0.62	0.62	0.62
Transit wait-ride score, $f_s$	1.95	1.95	1.95	1.95	1.95
Pedestrian LOS score, $PLOS$	1.92	1.98	2.09	2.99	2.33
TLOS score	3.36	3.37	3.39	3.52	3.42
LOS	C	C	C	D	C

- The existing local bus service operates every 10 minutes, has an average peak hour load factor of 125%, and has a scheduled travel speed through supersection C of 6 mph.
- The “before” PLOS values previously calculated are used.

As can be seen, service in supersection C generally operates at LOS C, with one section operating at LOS D due to a worse pedestrian environment. The section served by BRT will improve from a low LOS C to a high LOS B. The other sections will remain at LOS C, with the reduction in local bus headways compensated by reduced crowding, faster speeds, and an improved pedestrian environment along the street.

## 8. References

- AC Transit. *East Bay Rapid Transit Project in Alameda County: Traffic Analysis Report*. Oakland, Calif., January 2012.
- Manual on Uniform Traffic Control Devices*. Federal Highway Administration, Washington, D.C., 2009.





## V. Case Study 3: Long-Range Transportation Plan Analysis

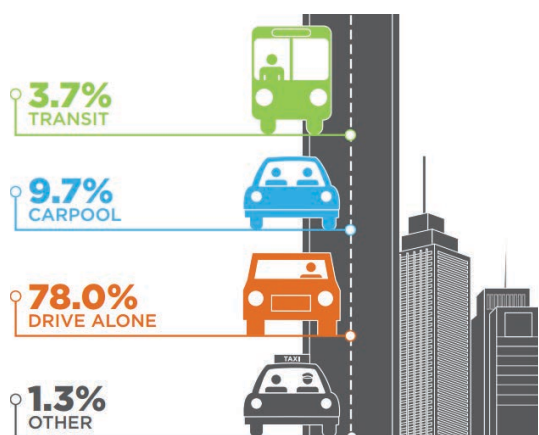

### 1. Overview

This case study illustrates the use of highway capacity and operations analysis in support of the development and update of a long-range transportation plan (LRTP) for a large region.

### Planning Objective

The objective is to perform the necessary transportation performance and investment alternatives analyses required to update the 2040 LRTP for the region. Auto, truck, bus, bicycle, and pedestrian analyses are to be performed.

### Background

The hypothetical metropolitan planning organization (MPO) for this example consists of a dozen cities and the unincorporated areas within a county covering approximately 6,000 square miles with a combined population of slightly fewer than 1 million persons (see Exhibit 183). The largest city within the MPO accounts for about half of the total county population. The county's population is forecasted to increase by 35% over the next 25 years. The highway network includes 2,100 directional miles of urban and rural arterial roads, 1,900 miles of collector roads, and 250 directional miles of urban and rural freeways.

### Example Problems Worked in this Case Study

The planning problems that will be illustrated by worked examples within this case study are:

- Example Problems that Develop Demand Model Inputs
  - Example 1: Estimating Free-Flow Speeds and Capacities for Model Input
  - Example 2: HCM-based Volume–Delay Functions for Model Input
- Example Problems that Post-Process Demand Model Outputs
  - Example 3: Predicting Density, Queues, and Delay
  - Example 4: Predicting Reliability

These planning problems illustrate the development, selection, and application of defaults for use in system-level planning analyses of large areas.

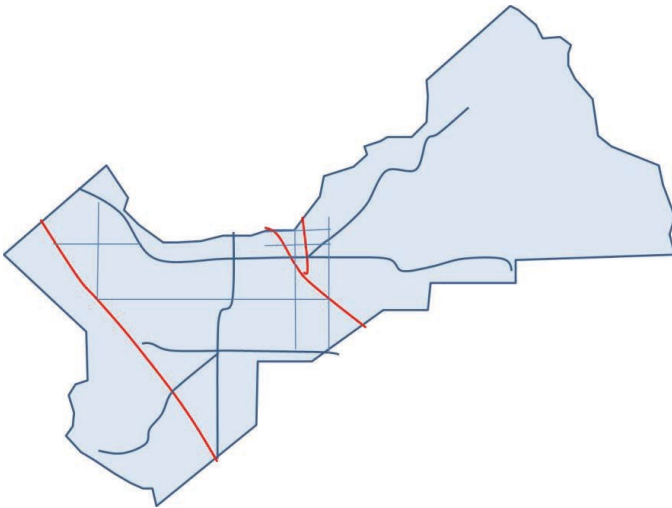
**Exhibit 183. Case study 3: MPO planning area.**

## 2. Example 1: Estimating Free-Flow Speeds and Capacities for Model Input

### Approach

This example illustrates how the HCM can be used to develop a look-up table of free-flow speeds and capacities for use in quickly coding large highway networks for a regional travel demand model. It illustrates the application of the methods described in Section R of the Guide.

The example will first identify an appropriate set of categories for representing the diversity of facility types, free-flow speeds, and per-lane capacities of the region's roadway facilities. Values for free-flow speeds and capacities will then be selected from the appropriate tables in Section R.

### Procedure

#### *Step 1: Identify Facility Categorization Scheme for Look-up Table*

Based on local knowledge of the diversity of facility types, area types, terrains, capacities, and free-flow speeds in the region, the analyst tentatively identifies five facility types and four area types for stratifying the regional roadway network into 20 possible different categories for the speed and capacity look-up table.

The HCM identifies four basic facility types: freeways, multilane highways, two-lane highways, and urban streets. The analyst, wishing to distinguish the differing capacity and operating characteristics between major and minor functional class facilities, has subdivided each of the HCM non-freeway facility types into major and minor facility subtypes.

The first two columns of Exhibit 184 show the resulting categories. Additional categories and subdivisions are possible depending on the analyst's needs and resources. The facilities may be further stratified by the general terrain in which they are located (level, rolling, and mountainous). Additional facility types may be created for on-ramps, off-ramps, collector-distributor roads within an interchange, and freeway-to-freeway ramps. A local road category may be added as well, if local roads will be included in the demand model.

**Exhibit 184. Case study 3: capacity and free-flow speed look-up table for highway system coding.**

Facility Type	Area Type	Free-Flow Speed (mph)	Capacity (veh/ln)
Freeway	Downtown	55	1,800
	Urban	60	1,800
	Suburban	65	1,900
	Rural	70	1,900
Principal Highway	Rural Multilane	55	1,700
	Rural Two-lane	55	1,300
Minor Highway	Rural Multilane	45	1,500
	Rural Two-lane	45	1,300
Arterial	Downtown	25	700
	Urban	35	700
	Suburban	45	600
Collector	Downtown	25	600
	Urban	30	600
	Suburban	35	600

**Step 2: Identify Free-Flow Speeds**

The analyst then identifies the appropriate default free-flow speed to be assumed for each facility and area type. These speeds are generally rounded to the nearest 5 miles per hour for the purposes of the look-up table and the initial coding of the highway network. Later, during model development and calibration, the analyst may fine tune the default free-flow speeds for specific links to obtain improved demand estimates from the model.

The procedures described in Section R4 of the Guide are followed to identify free-flow speeds by facility type, area type, and subtype (major and minor). The values shown in the third column of Exhibit 184 are taken from the illustrative look-up table of free-flow speed defaults in Section R4 (Exhibit 124). The analyst may follow the procedures described in Section R4 to develop his or her own values based on local conditions.

**Step 3: Identify Capacities**

The analyst identifies the appropriate default per-lane capacities to be assumed for each facility and area type. These capacities are generally rounded to the nearest 50 vehicles per hour per lane for the purposes of the look-up table and the initial coding of the highway network. Later, during model development and calibration, the analyst may fine tune the default capacities for specific links to obtain improved demand estimates from the model.

The procedures described in Section R4 of the Guide are followed to identify capacities by facility type, area type, and subtype (major and minor). The values shown in Exhibit 184 are taken from the 80% HCM Capacity column of Exhibit 128, Illustrative Per-lane Capacity Look-up Table. The 80% HCM Capacity is selected (rather than the 90% HCM Capacity) because the facilities in this region tend to experience higher truck percentages and lower peak hour factors. The analyst might choose to use a mix of 80% and 90% capacities to reflect different facility characteristics in the central business district of the region’s primary city relative to elsewhere in the region. The analyst may follow the procedures described in Section R4 to develop their own values based on local conditions and to develop capacities for additional facility subtypes.

### 3. Example 2: HCM-Based Volume–Delay Functions for Model Input

#### Approach

This example illustrates how the HCM can be used to develop volume–delay functions for a regional travel demand model. This example can also be followed when post-processing a travel demand model’s forecasted demands for air quality analysis purposes to more-accurately estimate average vehicle speeds under congested conditions. The procedures described in Section R5 of this Guide will be demonstrated. The example will develop a speed–flow equation that accurately reflects the queuing delays for use within the travel demand model’s traffic assignment process.

It is important to note there are many possible volume–delay functions that can be and are used in travel demand modeling. This example illustrates how the methods described in this Guide can be used with one of the more traditional volume–delay functions, the Bureau of Public Roads (BPR) function. This use is not meant to imply the superiority of the BPR function for use with the HCM or for any other purpose. In fact, other functions may be superior for demand modeling or predicting speeds, depending on the context of the specific application.

#### Procedure

##### Step 1: Identify Speed–Flow Curve Calibration Parameters

While not required to estimate free-flow speeds and capacities, the speed–flow curve calibration parameters are also identified in this step for each facility type, area type, and subtype. These parameters will be applied in Example 3 where link speeds are to be estimated, either during the traffic assignment stage of the demand model process, or as a post-processing step to be performed after the demand model run is complete. (The latter case might occur if more accurate congested speeds are needed for air quality analysis purposes.)

The appropriate speed at capacity and the consequent BPR speed–flow curve calibration parameters are obtained from Exhibit 129, reproduced below as Exhibit 185). The analyst finds the nearest equivalent to the facility, area, and subtypes selected for Exhibit 184, and the HCM

**Exhibit 185. Case study 3: speed–flow equation parameters.**

Facility Type	Area Type	Free-Flow Speed (mph)	Capacity (veh/ln)	HCM Base Speed at Capacity (mph)	BPR A Parameter	BPR B Parameter
Freeway	Downtown	55	1,800	50.0	0.10	7
	Urban	60	1,800	51.1	0.17	7
	Suburban	65	1,900	52.2	0.24	7
	Rural	70	1,900	53.3	0.31	7
Principal Highway	Rural Multilane	55	1,700	46.7	0.18	8
	Rural Two-lane	55	1,300	42.5	0.29	8
Minor Highway	Rural Multilane	45	1,500	42.2	0.07	9
	Rural Two-lane	45	1,300	32.5	0.38	9
Arterial	Downtown	25	700	6.7	2.71	3
	Urban	35	700	11.0	2.19	2
	Suburban	45	600	11.4	2.95	2
Collector	Downtown	25	600	6.7	2.71	3
	Urban	30	600	10.4	1.89	3
	Suburban	35	600	11.0	2.19	3

facility types and subtypes listed in Exhibit 185. In this case, the calibration parameters for the freeway basic sections in Exhibit 185 are selected to represent all freeway links in Exhibit 184. The multilane and two-lane rural highway values in Exhibit 185 are selected to represent the Principal and Minor Highway types in Exhibit 184. The urban and suburban values for segments with signals are selected in Exhibit 185 to represent the arterial and collector subtypes in Exhibit 184. Finally, the speed at capacity for a 30-mph free-flow speed facility is interpolated between the values shown for 25 and 35 mph free-flow speed facilities.

**Step 2: Apply the Speed–Flow Curve**

Exhibit 186 shows the speed estimates for six example freeway and arterial links. The computations proceed as follows:

1. The length, facility type, area type, and number of lanes are input by the modeler for each link.
2. The capacity and free-flow speed are obtained from the look-up table (Exhibit 185) according to the link’s facility type and area type.
3. The demand for the link is predicted by the demand model.
4. The speed at capacity is obtained from the look-up table (Exhibit 185) according to the link’s facility type and area type.
5. The ratio of the free-flow speed to the speed at capacity is used to estimate the BPR curve’s *A* parameter, and is given in the look-up table (Exhibit 185).
6. The *B* parameter of the BPR curve is obtained from the look-up table (Exhibit 185).
7. The demand-to-capacity ratio is computed for each link.
8. As free-flow speeds are available, the speed-based version of the BPR curve (Equation 203) is used to estimate travel speeds for each link.

For example, Link A001 in the model is an eight-lane urban freeway (i.e., four lanes per direction). From the look-up table (Exhibit 185), the per-lane capacity of an urban freeway is 1,800 veh/h; therefore, the capacity of a four-lane link would be  $4 \times 1,800 = 7,200$  veh/h. The look-up table also provides values for free-flow speed (60 mph) and the BPR curve’s *A* and *B* parameters (0.17 and 7, respectively). Finally, the travel demand model estimates a demand of 8,220 veh/h for the link, which results in a demand-to-capacity ratio of 1.14. With this information in hand, the link’s speed can then be estimated using Equation 203:

$$S = S_0 / (1 + Ax^B) = 60 / [1 + (0.17) \times (8,220 / 7,200)^7] = 42.0 \text{ mph}$$

Exhibit 186 demonstrates the estimation of travel speeds for six example links in the model.

**Exhibit 186. Case study 3: example application of speed–flow curve.**

Link ID	Facility Type	Lanes	Demand (veh/h)	Capacity (veh/h)	Free-Flow Speed (mph)	BPR A	BPR B	d/c Ratio	Speed (mph)
A001	Urban freeway	4	8,220	7,200	60	0.17	7	1.14	42.0
A002	Urban arterial	3	1,740	2,100	35	2.19	2	0.83	14.0
A003	Urban collector	2	1,170	1,200	30	1.89	3	0.98	10.9
A004	Rural freeway	2	2,790	3,800	70	0.31	7	0.73	67.6
A005	Rural principal highway	2	1,490	3,400	55	0.18	8	0.44	55.0
A006	Rural minor highway	1	250	1,300	45	0.38	9	0.19	45.0

Notes: d/c = demand-to-capacity ratio.

For reasonably precise travel time estimates, it is necessary to carry more significant digits than shown here throughout the speed computations.

### 4. Example 3: Predicting Density, Queues, and Delay

#### Approach

This example demonstrates post-processing travel demand model output to generate additional useful performance measures. In this case, measures of density, queues (vehicle-hours in queue, VHQ), and delay for each model link will be identified, tabulated, and reported, following the guidance in Section R5 of the Guide. The required model outputs are directional demand, capacity, lanes, and travel speed by link.

#### Procedure

##### Step 1: Compute Density

The average peak hour density *D* of vehicle traffic (in vehicles per mile per lane) for each direction of the link is computed by dividing the predicted demand rate *V* (in vehicles per hour) by the number of lanes *N* and the predicted average speed of traffic *S* (in miles per hour).

If it is desired to convert the density into a LOS for use with freeways and multilane highways, the calculated density must be converted into units of passenger cars, as described in Sections H6 (freeways) and I6 (multilane highways) of the Guide. In lieu of making the facility-specific computations, a default passenger car equivalent *PCE* value of 1.2 may be used to account for most typical conditions. The density calculation then becomes:

$$D = \frac{V \times PCE}{N \times S} \tag{Equation 206}$$

where all variables are as described above. Exhibit 187 summarizes the HCM’s LOS criteria by facility type and (where appropriate) location.

##### Step 2: Compute Vehicle-Hours In Queue

The vehicle-hours traveled (VHT) for each direction of each link with a predicted *d/c* greater than 1.00 is accumulated to obtain total VHQ for the highway system. Person-hours in queue can be obtained by multiplying the VHQ by an assumed average vehicle occupancy rate.

##### Step 3: Compute Vehicle-Hours Delay

Vehicle-hours and person-hours of delay are typically output by the travel demand model using thresholds specified by the analyst. Vehicle-hours and person-hours of travel time are

**Exhibit 187. Case study 3: LOS criteria for freeway and multilane highway facilities.**

LOS	Urban Freeway Facilities and Basic Segments	Rural Freeway Facilities and Basic Segments	Freeway Weaving Segments	Freeway Merge and Diverge Segments	Multilane Highways
A	≤11	≤6	≤10	≤10	≤11
B	>11–18	>6–14	>10–20	>10–20	>11–18
C	>18–26	>14–22	>20–28	>20–28	>18–26
D	>26–35	>22–29	>28–35	>28–35	>26–35
E	>35–45	>29–39	>35–43	>35	>35–45
F	>45 or any section has <i>d/c</i> >1.00	>39 or any section has <i>d/c</i> >1.00	>43 or <i>d/c</i> >1.00	<i>d/c</i> >1.00	>45 or <i>d/c</i> >1.00

Source: Adapted from HCM (2016), Exhibit 10-6, Exhibit 12-15, Exhibit 13-6, and Exhibit 14-3.

compared to an agency specified minimum speed goal for each link. The speed goal may be the link free-flow speed, or some other value reflecting agency policy.

The vehicle-hours of delay  $VHD$  for a link is computed by taking the difference between the actual VHT and the estimated VHT if all vehicles could have traversed the link at the agency's policy minimum acceptable speed  $S_p$  (in miles per hour) for the facility represented by the link:

$$VHD = \frac{V \times L}{S} - \frac{V \times L}{S_p} \quad \text{Equation 207}$$

where all variables are as defined previously.

#### Step 4: Interpreting Results

Density can be compared to HCM thresholds to obtain a sense of the degree of congestion represented by the density. System VHD and VHQ can be compared across alternatives to obtain a sense of the degree to which one alternative is better than the other. VHD can also be used in economic cost-benefit analyses.

## 5. Example 4: Predicting Reliability

### Approach

This example demonstrates the prediction of automobile travel time reliability for a freeway link, following the simplified HCM method described in Section H7 of the Guide. The travel demand model outputs required are the link's peak hour speed, free-flow speed, number of lanes, and demand-to-capacity ratio.

### Procedure

#### Step 1: Compute Average Annual Travel Time Index for Each Link

The average annual travel time index for a freeway link is computed from its free-flow speed, peak hour speed, and its peak hour volume/capacity ratio. First, the recurring delay rate ( $RDR$ ) for the link (in hours per mile) is calculated from the peak hour and free-flow speeds using Equation 33. Using the data for Link A001 in Example 2 (Exhibit 186), the free-flow speed is 60 mph, the peak hour speed is 42.0 mph, and the recurring delay rate is then:

$$RDR = \frac{1}{S} - \frac{1}{FFS} = \frac{1}{42.0} - \frac{1}{60} = 0.0071 \text{ h/mi}$$

Next, the incident delay rate ( $IDR$ ) (Equation 34) for the link (in hours per mile) is calculated from the number of directional lanes on the link and the link's demand-to-capacity ratio (capped at 1.00). Again using the data for Link A001, the number of directional lanes is 4 and the  $d/c$  ratio is 1.14, which is reduced to 1.00 for use in calculating  $IDR$ . Then:

$$IDR = [0.020 - (N - 2) \times 0.003] \times X^{12} = [0.020 - (4 - 2) \times 0.003] \times 1.00^{12} = 0.014 \text{ h/mi}$$

Finally, the average annual travel time index  $TTI_m$  is calculated using Equation 32. The link free-flow speed is an input to the equation. For Link A001, the free-flow speed is 60 mph and  $TTI_m$  is then:

$$TTI_m = 1 + FFS \times (RDR + IDR) = 1 + 60 \times (0.0071 + 0.014) = 2.27$$

Similarly, applying the data for Link A004 from Example 2,  $RDR$  is 0.0005,  $IDR$  is 0.0005, and  $TTI_m$  is 1.07.

### Step 2: Compute Average Annual Travel Time Index for the System

The average annual travel time index for the system is the system VHT (sum of link VHTs) divided by the theoretical VHT if all VMT were completed at free-flow speeds. If, for the sake of example, one defines the system to consist solely of the two freeway links from Example 2, A001 and A004, the calculations proceed as follows.

For Link A001, the link length is 0.85 miles, the free-flow speed is 60 mph, the peak hour speed is 42.0 mph, and the link demand is 8,220 veh/h. VHT at free-flow speed would be  $(0.85/60) \times 8,220 = 116$ , while peak hour VHT is  $(0.85/42.0) \times 8,220 = 166$ .

Similarly, for Link A004, the link length is 2.50 miles, the free-flow speed is 70 mph, the peak hour speed is 67.6 mph, and the link demand is 2,790 veh/h. VHT at free-flow speed would be  $(2.50/70) \times 2,790 = 100$ , while peak hour VHT is  $(2.50/67.6) \times 2,790 = 103$ .

The system average annual travel time index  $TTI_{m,sys}$  is then:

$$TTI_{m,sys} = \frac{166 + 103}{116 + 100} = 1.25$$

### Step 3: Compute Reliability Statistics for System

The 95th percentile travel time index  $TTI_{95}$  and percent of trips traveling under 45 mph  $PT_{45}$  for the system can be estimated from the system average annual travel time index  $TTI_{m,sys}$  using Equation 35 and Equation 36, respectively.

$$TTI_{95,sys} = 1 + 3.67 \times \ln(TTI_{m,sys}) = 1 + 3.67 \times \ln(1.25) = 1.82$$

$$PT_{45,sys} = 1 - \exp[-1.5115 \times (TTI_{m,sys} - 1)] = 1 - \exp[-1.5115 \times (1.25 - 1)] = 0.31$$

## 6. Reference

*Highway Capacity Manual: A Guide to Multimodal Mobility Analysis*. 6th ed. Transportation Research Board, Washington, D.C., 2016.



*Abbreviations and acronyms used without definitions in TRB publications:*

A4A	Airlines for America
AAAAE	American Association of Airport Executives
AASHO	American Association of State Highway Officials
AASHTO	American Association of State Highway and Transportation Officials
ACI-NA	Airports Council International-North America
ACRP	Airport Cooperative Research Program
ADA	Americans with Disabilities Act
APTA	American Public Transportation Association
ASCE	American Society of Civil Engineers
ASME	American Society of Mechanical Engineers
ASTM	American Society for Testing and Materials
ATA	American Trucking Associations
CTAA	Community Transportation Association of America
CTBSSP	Commercial Truck and Bus Safety Synthesis Program
DHS	Department of Homeland Security
DOE	Department of Energy
EPA	Environmental Protection Agency
FAA	Federal Aviation Administration
FAST	Fixing America's Surface Transportation Act (2015)
FHWA	Federal Highway Administration
FMCSA	Federal Motor Carrier Safety Administration
FRA	Federal Railroad Administration
FTA	Federal Transit Administration
HMCRP	Hazardous Materials Cooperative Research Program
IEEE	Institute of Electrical and Electronics Engineers
ISTEA	Intermodal Surface Transportation Efficiency Act of 1991
ITE	Institute of Transportation Engineers
MAP-21	Moving Ahead for Progress in the 21st Century Act (2012)
NASA	National Aeronautics and Space Administration
NASAO	National Association of State Aviation Officials
NCFRP	National Cooperative Freight Research Program
NCHRP	National Cooperative Highway Research Program
NHTSA	National Highway Traffic Safety Administration
NTSB	National Transportation Safety Board
PHMSA	Pipeline and Hazardous Materials Safety Administration
RITA	Research and Innovative Technology Administration
SAE	Society of Automotive Engineers
SAFETEA-LU	Safe, Accountable, Flexible, Efficient Transportation Equity Act: A Legacy for Users (2005)
TCRP	Transit Cooperative Research Program
TDC	Transit Development Corporation
TEA-21	Transportation Equity Act for the 21st Century (1998)
TRB	Transportation Research Board
TSA	Transportation Security Administration
U.S.DOT	United States Department of Transportation

**TRANSPORTATION RESEARCH BOARD**  
500 Fifth Street, NW  
Washington, DC 20001

**ADDRESS SERVICE REQUESTED**

*The National Academies of*  
SCIENCES • ENGINEERING • MEDICINE

The nation turns to the National Academies of Sciences, Engineering, and Medicine for independent, objective advice on issues that affect people's lives worldwide.

[www.national-academies.org](http://www.national-academies.org)

ISBN 978-0-309-37565-8



9 780309 375658

NON-PROFIT ORG.  
U.S. POSTAGE  
**PAID**  
COLUMBIA, MD  
PERMIT NO. 88