

Technologies to Support the Storage, Retrieval, and Use of 3-D Utility Location Data

DETAILS

306 pages | 8.5 x 11 | PAPERBACK

ISBN 978-0-309-43285-6 | DOI 10.17226/22231

BUY THIS BOOK

FIND RELATED TITLES

AUTHORS

William Gale and Andrew Hammerschmidt; Strategic Highway Research Program; Strategic Highway Research Program Renewal Focus Area; Transportation Research Board; National Academies of Sciences, Engineering, and Medicine

Visit the National Academies Press at NAP.edu and login or register to get:

- Access to free PDF downloads of thousands of scientific reports
- 10% off the price of print titles
- Email or social media notifications of new titles related to your interests
- Special offers and discounts



Distribution, posting, or copying of this PDF is strictly prohibited without written permission of the National Academies Press. (Request Permission) Unless otherwise indicated, all materials in this PDF are copyrighted by the National Academy of Sciences.

The Second

S T R A T E G I C H I G H W A Y R E S E A R C H P R O G R A M



SHRP 2 REPORT S2-R01A-RW-1

Technologies to Support Storage, Retrieval, and Use of 3-D Utility Location Data

WILLIAM GALE AND ANDREW HAMMERSCHMIDT
Gas Technology Institute
Des Plaines, Illinois

TRANSPORTATION RESEARCH BOARD

WASHINGTON, D.C.
2015
www.TRB.org

Subject Areas

Construction

Data and Information Technology

Highways

The Second Strategic Highway Research Program

America's highway system is critical to meeting the mobility and economic needs of local communities, regions, and the nation. Developments in research and technology—such as advanced materials, communications technology, new data collection technologies, and human factors science—offer a new opportunity to improve the safety and reliability of this important national resource. Breakthrough resolution of significant transportation problems, however, requires concentrated resources over a short time frame. Reflecting this need, the second Strategic Highway Research Program (SHRP 2) has an intense, large-scale focus, integrates multiple fields of research and technology, and is fundamentally different from the broad, mission-oriented, discipline-based research programs that have been the mainstay of the highway research industry for half a century.

The need for SHRP 2 was identified in *TRB Special Report 260: Strategic Highway Research: Saving Lives, Reducing Congestion, Improving Quality of Life*, published in 2001 and based on a study sponsored by Congress through the Transportation Equity Act for the 21st Century (TEA-21). SHRP 2, modeled after the first Strategic Highway Research Program, is a focused, time-constrained, management-driven program designed to complement existing highway research programs. SHRP 2 focuses on applied research in four areas: Safety, to prevent or reduce the severity of highway crashes by understanding driver behavior; Renewal, to address the aging infrastructure through rapid design and construction methods that cause minimal disruptions and produce lasting facilities; Reliability, to reduce congestion through incident reduction, management, response, and mitigation; and Capacity, to integrate mobility, economic, environmental, and community needs in the planning and designing of new transportation capacity.

SHRP 2 was authorized in August 2005 as part of the Safe, Accountable, Flexible, Efficient Transportation Equity Act: A Legacy for Users (SAFETEA-LU). The program is managed by the Transportation Research Board (TRB) on behalf of the National Research Council (NRC). SHRP 2 is conducted under a memorandum of understanding among the American Association of State Highway and Transportation Officials (AASHTO), the Federal Highway Administration (FHWA), and the National Academy of Sciences, parent organization of TRB and NRC. The program provides for competitive, merit-based selection of research contractors; independent research project oversight; and dissemination of research results.

SHRP 2 Report S2-R01A-RW-1

ISBN: 978-0-309-27459-3

© 2015 National Academy of Sciences. All rights reserved.

Copyright Information

Authors herein are responsible for the authenticity of their materials and for obtaining written permissions from publishers or persons who own the copyright to any previously published or copyrighted material used herein.

The second Strategic Highway Research Program grants permission to reproduce material in this publication for classroom and not-for-profit purposes. Permission is given with the understanding that none of the material will be used to imply TRB, AASHTO, or FHWA endorsement of a particular product, method, or practice. It is expected that those reproducing material in this document for educational and not-for-profit purposes will give appropriate acknowledgment of the source of any reprinted or reproduced material. For other uses of the material, request permission from SHRP 2.

Note: SHRP 2 report numbers convey the program, focus area, project number, and publication format. Report numbers ending in “w” are published as web documents only.

Notice

The project that is the subject of this report was a part of the second Strategic Highway Research Program, conducted by the Transportation Research Board with the approval of the Governing Board of the National Research Council.

The members of the technical committee selected to monitor this project and review this report were chosen for their special competencies and with regard for appropriate balance. The report was reviewed by the technical committee and accepted for publication according to procedures established and overseen by the Transportation Research Board and approved by the Governing Board of the National Research Council.

The opinions and conclusions expressed or implied in this report are those of the researchers who performed the research and are not necessarily those of the Transportation Research Board, the National Research Council, or the program sponsors.

The Transportation Research Board of the National Academies, the National Research Council, and the sponsors of the second Strategic Highway Research Program do not endorse products or manufacturers. Trade or manufacturers' names appear herein solely because they are considered essential to the object of the report.



SHRP 2 Reports

Available by subscription and through the TRB online bookstore:

www.mytrb.org/store

Contact the TRB Business Office:

202-334-3213

More information about SHRP 2:

www.TRB.org/SHRP2

THE NATIONAL ACADEMIES

Advisers to the Nation on Science, Engineering, and Medicine

The **National Academy of Sciences** is a private, nonprofit, self-perpetuating society of distinguished scholars engaged in scientific and engineering research, dedicated to the furtherance of science and technology and to their use for the general welfare. On the authority of the charter granted to it by Congress in 1863, the Academy has a mandate that requires it to advise the federal government on scientific and technical matters. Dr. Ralph J. Cicerone is president of the National Academy of Sciences.

The **National Academy of Engineering** was established in 1964, under the charter of the National Academy of Sciences, as a parallel organization of outstanding engineers. It is autonomous in its administration and in the selection of its members, sharing with the National Academy of Sciences the responsibility for advising the federal government. The National Academy of Engineering also sponsors engineering programs aimed at meeting national needs, encourages education and research, and recognizes the superior achievements of engineers. Dr. C. D. (Dan) Mote, Jr., is president of the National Academy of Engineering.

The **Institute of Medicine** was established in 1970 by the National Academy of Sciences to secure the services of eminent members of appropriate professions in the examination of policy matters pertaining to the health of the public. The Institute acts under the responsibility given to the National Academy of Sciences by its congressional charter to be an adviser to the federal government and, on its own initiative, to identify issues of medical care, research, and education. Dr. Victor J. Dzau is president of the Institute of Medicine.

The **National Research Council** was organized by the National Academy of Sciences in 1916 to associate the broad community of science and technology with the Academy's purposes of furthering knowledge and advising the federal government. Functioning in accordance with general policies determined by the Academy, the Council has become the principal operating agency of both the National Academy of Sciences and the National Academy of Engineering in providing services to the government, the public, and the scientific and engineering communities. The Council is administered jointly by both Academies and the Institute of Medicine. Dr. Ralph J. Cicerone and Dr. C. D. (Dan) Mote, Jr., are chair and vice chair, respectively, of the National Research Council.

The **Transportation Research Board** is one of six major divisions of the National Research Council. The mission of the Transportation Research Board is to provide leadership in transportation innovation and progress through research and information exchange, conducted within a setting that is objective, interdisciplinary, and multimodal. The Board's varied activities annually engage about 7,000 engineers, scientists, and other transportation researchers and practitioners from the public and private sectors and academia, all of whom contribute their expertise in the public interest. The program is supported by state transportation departments, federal agencies including the component administrations of the U.S. Department of Transportation, and other organizations and individuals interested in the development of transportation. www.TRB.org

www.national-academies.org

SHRP 2 STAFF

Ann M. Brach, *Director*
Stephen J. Andrie, *Deputy Director*
Cynthia Allen, *Editor*
Kenneth Campbell, *Chief Program Officer, Safety*
Jared Cazel, *Editorial Assistant*
JoAnn Coleman, *Senior Program Assistant, Capacity and Reliability*
Eduardo Cusicanqui, *Financial Officer*
Richard Deering, *Special Consultant, Safety Data Phase 1 Planning*
Shantia Douglas, *Senior Financial Assistant*
Charles Fay, *Senior Program Officer, Safety*
Carol Ford, *Senior Program Assistant, Renewal and Safety*
James Hedlund, *Special Consultant, Safety Coordination*
Alyssa Hernandez, *Reports Coordinator*
Ralph Hessian, *Special Consultant, Capacity and Reliability*
Andy Horosko, *Special Consultant, Safety Field Data Collection*
William Hyman, *Senior Program Officer, Reliability*
Linda Mason, *Communications Officer*
David Plazak, *Senior Program Officer, Capacity and Reliability*
Rachel Taylor, *Senior Editorial Assistant*
Dean Trackman, *Managing Editor*
Connie Woldu, *Administrative Coordinator*

ACKNOWLEDGMENTS

This work was sponsored by the Federal Highway Administration in cooperation with the American Association of State Highway and Transportation Officials. It was conducted in the second Strategic Highway Research Program (SHRP 2), which is administered by the Transportation Research Board of the National Academies. The project was managed by Charles Taylor, Special Consultant for SHRP 2 Renewal; James Bryant, Senior Program Officer for SHRP 2 Renewal; and Andy Horosko, Special Consultant for SHRP 2 Renewal. Ralph Hessian, Special Consultant for SHRP 2 Renewal, also contributed to this report.

The research reported on herein was performed by Gas Technology Institute, Inc. (GTI), supported by Bentley Systems Incorporated, J.H. Anspach Consulting, Sentinel Inc., and GL Industrial Services. William Gale, GTI Senior Engineer, was the principal investigator. Andrew Hammerschmidt, GTI R&D Director, was the project manager. The other authors of this report include the Bentley Systems Incorporated team, led by Dennis Pettit. The authors would like to thank the Virginia Department of Transportation and Maryland Department of Transportation for their contributions to this research.

FOREWORD

Andy Horosko and Ralph Hessian, *SHRP 2 Special Consultants, Renewal*

This report documents 3-D utility location literature and project review findings, the development of a nonproprietary 3-D utility location data repository, and the use of the repository in a pilot demonstration using actual utility location data from a road renewal project. The report will be of interest to engineers and others exploring ways to enhance practices for capturing, storing, using, and maintaining 3-D utility information, as well as to software vendors of road planning, design, and construction software products.

Underground utility installations are common within highway rights-of-way. The location and specific characteristics of many buried utility lines have not been properly documented and thus present a unique challenge for highway renewal projects. The discovery of unexpected utility lines during a project's delivery can pose considerable risk to workers' safety and disrupt the established project schedule. Highway renewal projects depend on the availability of accurate underground utility records and information to support effective planning, design, and delivery.

Providing the necessary underground utility information for road renewal projects requires a suite of innovative nondestructive technologies and methods and a decision support framework that can address the complexity of varying utilities, site soil, geology, and environmental conditions. SHRP 2 Project R01, Encouraging Innovation in Locating and Characterizing Underground Utilities, provided the background and basis for a series of research and development projects that aimed to provide products to serve this highway renewal business need.

This report presents information on a project undertaken to use 3-D utility location information for planning, design, and construction of highway renewal work and to develop long-term storage of the 3-D utility location information for use on future projects. Information on current practices and protocols for addressing aboveground and belowground utility location data was assembled from a domestic and international literature search and a review of a number of selected projects.

These findings, together with input from a workshop, the expertise of the project team, and the knowledge of current commercially available technologies and software, were used to develop a framework of policies, procedures, and systems to store, retrieve, and use 3-D utility location data in highway renewal projects. Brief commentary is provided on conceptual workflows and software, system, and administrative needs.

A 3-D utility location data repository was developed to support the project. The repository, developed on a standard relational database product, was based on the federal Spatial Data Standards for Facilities, Infrastructure, and Environment database (SDSFIE 3.0). For this project, the SDSFIE data model was modified and extended to add additional features, to provide a richer set of definitions, and to permit 3-D spatial features storage. The repository can be used to support planning, design, and construction activity, as well as to store 3-D utility location information for future highway renewal projects.

A limited pilot demonstration using the 3-D utility location data repository and commonly available software tools is documented. The demonstration using right-of-way utility information from a state highway renewal project discusses the uploading, using, updating, and storing of 3-D utility location data.

CONTENTS

1	Executive Summary
5	CHAPTER 1 Background
5	Project Background
5	Research Objective
5	Scope of Study
7	CHAPTER 2 Literature Search and Information Gathering
7	List of Projects and Papers
7	Projects Reviewed
8	Papers Reviewed
9	Findings from Literature Search and Information Gathering
10	CHAPTER 3 Solution Framework
10	Approach and Process
10	Workshop
10	Key Challenges
11	Proposed Framework and Conceptual Workflow
15	Data and Administrative Issues
18	CHAPTER 4 3-D Data Model and Data Repository
18	Data Model Organization
18	Reproducing the Prototype 3-D Utility Data Repository
21	CHAPTER 5 Proof-of-Concept Pilot Demonstration
21	System and Process
23	Working with the Model
41	CHAPTER 6 Conclusions and Recommendations
41	Recommendations
42	Conclusions
43	References
44	Appendix A. Data Schema
192	Appendix B. Oracle Spatial DDL

Executive Summary

Introduction

Most highway renewal projects require the establishment of an underground utility inventory before detailed design. The processes used to establish a complete understanding (positional and functional) of the underground utilities can be costly and time-consuming. Often a project area is composed of one or more sections of previous renewal projects where the utility inventory was established and well documented. The number of underground utility changes since the last construction project may be few; however, processes to track these changes have not been established. Some of the records that document the underground utility changes may be insufficient, incorrect, or difficult to obtain. Because there is no mechanism in place to track changes to department of transportation (DOT) rights-of-way, the entire project area is resurveyed, which requires locating 100% of existing utilities when only a small percentage of these have undergone change. SHRP 2 Renewal Project R01A developed several strategies, processes, and systems to acquire, store, use, and maintain 3-D utility location data from prior projects, which will help prevent repeated re-inventory of utility features on new renewal projects. The SHRP 2 R01A project's resulting products have the potential to help avoid problems typically encountered from delays that unknown utilities may cause, as well as to avoid damage to utilities from dig ins and service interruptions. The proposed solution was crafted for use during planning, design, and construction. The solution has potential value as a dynamic, day-to-day process for maintaining an accurate database of all such features for the management of assets (both DOT and permitted encroachments) within highway rights-of-way and thus may have even greater usefulness for DOTs and transportation users.

The SHRP 2 R01A project was executed in three phases. Phase 1 consisted of a literature search of the best practices worldwide for cataloging and maintaining utility infrastructure. The Phase 1 research identified a strategy to create a solution that would serve the needs of state DOTs on future renewal projects. A proof-of-concept model was developed to test the viability of the Phase 1 strategy and the capability of the system to integrate with DOT project design. This Phase 1 testing included a verification of the system's suitability for maintaining the utility record in the DOT right-of-way during design and construction, as well as for subsequent renewal projects. The Phase 2 work tested the processes and systems for scalability, relevance to the DOT design process, and validity of the results for implementation in the Phase 3 pilot. Phase 3 incorporated all underground utility features from a project located in Northern Virginia at the intersection of Route 29 and Gallows Road. The Phase 3 pilot project used the technology from the Phase 2 proof of concept but included a much larger set of data, simulating underground utilities on a typical DOT project. The pilot system and work processes developed in Phase 3 provided an opportunity to test the basic 3-D utility model for completeness. The 3-D model was used in several workflows, proving the capability of the system to perform basic

highway-design work and demonstrating the suitability of the overall solution for future DOT renewal projects.

The SHRP 2 R01A pilot project at Route 29 and Gallows Road established a number of administrative and technological practices required to acquire, preserve, and maintain the utility record for all future projects. The pilot system demonstrated the use of many types of data typically used to define the true 3-D nature of the utility features. One of the strengths of the pilot system was the application of quality levels as defined by the ASCE 38 standard (Standard Guideline for the Collection and Depiction of Existing Subsurface Utility Data, ASCE/CI 38-02). The system transforms the ASCE 38 classified underground utility features into an easily understandable graphic. The graphic is created through the use of symbology discretely rendering each utility feature's quality level. All utility features with quality levels A through D are loaded into the system, and each classification level is easily distinguished by color, line size, or a combination of symbology and color.

Phase 1 Findings

The Phase 1 literature research resulted in a number of findings that formed the basis of the development of the Phase 2 proof of concept:

- The reviewed projects contained an integrated view of all utilities in the right-of-way.
- To manage change, several of the organizations had a systematic means of identifying and recording change.
- The permitting agencies that issue permits within the DOT right-of-way should provide a systematic and direct means of defining areas where the underground utilities have changed.
- All of the systems were based on a centrally processed data store. While many DOTs operate by region or division, the system design should offer the opportunity to consolidate the data stored for underground utilities into a single statewide system.
- Multiple organizations accessed the data for a variety of purposes. This finding suggested that the system proposed should allow secured and controlled access to a variety of users. The system should also deliver the data in a form that can be accessed by a variety of viewing and editing tools.
- Almost without exception, the literature pointed to process reengineering as a key element of the various implementations. Process reengineering was one of the main change catalysts that provided significant efficiency improvement and accounted for much of the cost savings.
- The implementation of a data quality standard was found in only one instance. However, because several of the research papers provided many strong arguments for implementing a data quality standard, it is included as one of the more significant findings.
- One area that needed process improvement was the practice of recording as-built underground utility locations postconstruction. The traditional practice of marking up a set of design plans (as-built locations by exception) could lead to inaccurate utility data. Sampling processes that generate actual location and utility definition are better suited to ensuring that the actual locations of the underground utilities are recorded and known.
- Finally, the Virginia DOT implemented the use of RFID markers for permanent marking as a best practice. This best practice has proved its value: damage to several utilities during construction was avoided.

System Overview

Using the results of the literature search, the proof-of-concept system was crafted to address a number of the findings and included three logical components: (1) a content management system; (2) a 3-D utility data storage system; and (3) a client component for viewing and editing the underground utilities.

Content Management System

The content management system allows the collection of utility data in many different formats and serves multiple purposes. The system

- Provides a staging platform for collection of utility data and any associated records for processing into the 3-D utility model;
- Allows the classification of underground utility source data to ASCE 38 quality levels; and
- Will allow for direct viewing of the base files in 2-D space.

The content management system is a logical collection and notification point for all changes (permits) to the project area during design and construction and subsequent to project completion.

3-D Utility Data Storage System

The 3-D utility data storage system was built on a standard relational database product, Oracle with Oracle Spatial as a spatial overlay environment. Any number of relational database products could have been used for the pilot (e.g., IBM DB2, IBM Informix, Microsoft SQL Server), but Oracle Spatial was chosen because it is the product most commonly found in many state DOT computing environments. The decision to store the 3-D utility data in a spatial environment was made to satisfy scalability concerns. The utility data being stored is 3-D point, line, and polygon data modeled using the federal Spatial Data Standards for Facilities, Infrastructure, and Environment database (SDSFIE 3.0). The SDSFIE data model was modified and extended to provide a richer set of definitions for underground utility features and to allow 3-D spatial features storage. Additionally, SDSFIE was extended to store and supply a number of additional features not commonly found in SDSFIE, features that can be processed to manage change and provide additional base map information common to highway design.

The 3-D utility data storage system is used to store and maintain the utility system of record for DOTs. It is envisioned that all underground utility design, underground utility as-built conditions, and permits will be stored and maintained in the 3-D storage system, providing the utility record for future renewal projects. During the pilot project, several demonstrations were performed to show utility design using the system.

Client System

The third component of the system, the client tools section, is represented by a variety of engineering tools commonly used by DOT designers. Bentley System's MicroStation, InRoads, Bentley Map, and several web-based viewing tools were used to demonstrate the interoperability of the various CAD and spatial products. Because the demonstration was limited in time, additional non-Bentley viewing and editing tools were not demonstrated for their ability to view and edit the 3-D utility features stored in the 3-D utility data storage system.

Conclusions

The practice of re-inventorying utilities for future DOT projects can be avoided by implementing a solution described in detail in this report. The results of this project demonstrate that 3-D utility data can be collected, stored, and maintained in a single statewide system for direct use in future highway renewal projects.

Each state DOT will directly benefit by including all the utility underground features in the system. Adopting, adapting, and using the 3-D model (see Appendix A and Appendix B) in multiple states will provide opportunities for DOTs to transparently share data where projects span state boundaries.

4

Instituting a change control process over project sites is a key R01A project recommendation for avoiding re-inventory of entire underground utility systems. In particular, a permitting process will serve as a primary way to avoid re-inventory when underground utility data are changed and will ensure that the underground utility system of record can be relied on for use in future highway renewal projects.

The system was built on technology that allows the generation of fully defined 3-D CAD features from single point, line, and polygon spatial definitions. Without this technology, it would be difficult to store all the utility features under an entire state's highway system and scale it for performance. While this technology is not new, this is the first time this technology has been used to manage the scalability concerns regarding storing large vector-based CAD models to create a 3-D underground utility system of record. This capability is available in other vendors' CAD systems, but it is not necessarily being used for the purposes demonstrated in this research project. Successful implementation of the techniques, processes, and recommendations described in this report using other CAD technology providers can be achieved by using developers and business partners intimately familiar with the spatial storage environments supported by the different CAD vendors' products.

CHAPTER 1

Background

Project Background

Quoting from the SHRP 2 R01 project posting:

It is commonly held among transportation officials that the accurate location and characterization of utilities (both above and below ground) and other similar facilities, especially deeply-buried ones, and their timely protection or relocation is a major factor in preventing delays in highway renewal projects. Such delays can extend the period of project development and impede construction delivery as documented in the final report for SHRP 2 Project R01, “Encouraging Innovation in Locating and Characterizing Underground Utilities.” Inaccurate location of utilities contributes to traffic and community disruption when service lines are encountered unexpectedly or access by utility repair crews is blocked by construction activities. Inadvertent damage to underground utilities can lead to environmental damage or even put the health and safety of construction workers and the public at risk.

Because utilities often are co-located on highway rights-of-way, renewal projects are vulnerable to utility-related delay and disruption. It is important to develop accurate plans that fully consider utilities and, by knowing this information early in the project development process, develop effective and cost-efficient strategies to protect or relocate the utility or provide alternative service to utility customers if service must be interrupted temporarily. Currently, many underground utilities are difficult to locate and characterize and often impede progress of transportation projects. Utilities can become “lost” as construction alters the landscape and preexisting benchmarks are removed. In the worst cases, no information exists until the utility is encountered during construction. These situations often result in significant delays to construction because work is suspended while utilities are relocated or the facility is redesigned. Unplanned service interruptions have even wider impact on communities served by the utility. The importance of this topic has led to an increased focus by project and utility owners in recent years as the current capabilities are taxed by renewal projects of increasing complexity. (TRB 2009)

Research Objective

The objective of SHRP 2 Renewal Project R01A was to develop a framework and to execute a pilot project to support and encourage the adoption of technologies to collect, use, update, and store 3-D utility information on highway right-of-way construction projects. Specifically, this included the methods and procedures, as well as the system, to create a 3-D model documenting as-built utilities and their locations. Collectively, the strategy, framework, methods, procedures and system will be referred to as the “solution.”

The processes and procedures used to maintain the 3-D utility information were to be flexible enough to support projects, with as-built documents available to state departments of transportation (DOT) to establish the utility record. In addition, the process and system had to accept the as-built records, whatever form they might be in, and create processes and a storage environment for the perpetual storage and maintenance of the 3-D utility model under the DOT right-of-way.

The work to be performed was expected to provide data management recommendations, identify new technology to improve the capture of aboveground and underground utilities, and recommend a system architecture for 3-D utility location data in highway renewal. The system, when implemented, was expected to reduce the costs and delays common to DOT construction projects that result from an incomplete understanding of the utility infrastructure and to store the utility data in 3-D for all future DOT renewal projects.

Scope of Study

Quoting again from the SHRP 2 R01 project posting (TRB 2009), the original scope of the study was as follows:

The project is intended to develop alternative strategies for acquiring 3-D utility location data and implement a pilot project within a defined geographic area including a number of participating utilities. The project will provide a demonstration

of the access control, data security, data pedigree (based on the Standard Guideline for the Collection and Depiction of Existing Subsurface Utility Data, CI/ASCE 38-02), positioning uncertainty, available characterization data, and liability issues that would be faced in a full-scale implementation of the system. Ongoing database management issues, data ownership, and data sharing shall be discussed. Providing documented examples of solutions to these administrative and legal issues is an important part of the project. The project should include implementation of positional and structural data capture involving the participating agency and the participating utilities for new utility installations and exposure of existing utilities, and the removal or updating of the status of those utilities that may have undergone relocation. The project shall include the pilot implementation of computerized utilities' data, maps, and models. This implementation will be used in utility locating and characterization for design purposes, and for damage prevention in excavation or construction projects. Existing laws and best practices regarding utility damage prevention should be followed. The advantages and disadvantages of the proposed approaches should be recorded.

The scope of the study was adjusted several times as the study progressed from the project's start in September 2009 to the proof of concept/pilot demonstration in July 2013. A significant redirection and narrowing of the scope occurred in January 2012 following a 9-month hold on research activities. With the narrowed scope, many of the study objectives were not addressed to the level of detail originally anticipated but rather were addressed in a more general way through narrative and recommendations. The reduced scope included the development of a nonproprietary 3-D utility location data repository and a proof of concept/pilot demonstration. The proof of concept/pilot demonstration involved taking utility infrastructure (e.g., water main, gas main, telecom segment) located in a highway right-of-way of an actual field project segment, loading it into editing tools, posting the utility infrastructure segment into the developed 3-D storage repository, extracting the same section of utility infrastructure from the 3-D data repository, updating it with a change, and posting the updated utility feature back into the 3-D data storage repository.

CHAPTER 2

Literature Search and Information Gathering

A literature search was performed, and industry subject matter experts were engaged to identify best practices from examples of existing coordinated 3-D mapping/modeling protocols and projects involving multiple utilities. The TRB request for proposals (RFP) asked that the literature review be performed on international projects. But after a concerted effort searching only for international projects, GTI increased the scope of the search to include both international and domestic projects. A field of 40 projects was inventoried. Twenty-nine of the 40 projects reviewed were eliminated for content, timing, or applicability. Eleven projects, both international and domestic, were identified as having value for the purposes of the literature search. Additionally, several academic papers were reviewed for basic research to explore a relatively new vendor-neutral standard for defining, storing, and interchanging 3-D spatial features. Four of the more noteworthy papers, from the international sources, are recorded in the list below.

List of Projects and Papers

1. Virginia Utility Protection Services (VUPS) Pilot Program, Roanoke, Virginia.
2. Utility Mapping Program, Hillsborough County, Florida.
3. Geospatially Enabled Community Collaboration (GECCO) Initiative, Tampa, Florida.
4. Road Information Center (ROADIC) Program, Tokyo, Japan (GITA, ROADIC Task Force 2003).
5. Federal Aviation Administration (FAA) Airport Surveying GIS Program.
6. Baltimore-Washington International Airport (BWI) CAD to GIS Conversion Program.
7. Alaskan Way Viaduct and Seawall Replacement (AWVSR) Project, Washington State DOT (WSDOT) and City of Seattle.
8. Mapping the Underworld (MTU), United Kingdom.
9. Virginia Department of Transportation (VDOT) Marker Ball Program, Virginia.
10. National Underground Assets Group (NUAG), United Kingdom.
11. Enterprise GIS Phoenix Sky Harbor International Airport, Phoenix, Arizona.
12. Extending 2-D Interoperability Frameworks to 3-D (Müller and Curtis, no date).
13. A Step Toward Interoperability: Managing 3-D Urban Data Within GML Structure (Scianna et al. 2006).
14. Conceptual Requirements for the Automatic Reconstruction of Building Information Models from Uninterrupted 3-D Models (Nagel et al. 2009).
15. Making Interoperability Persistent: A 3-D Geo Database Based on CityGML (Stadler et al. 2008).

Projects Reviewed

During the literature search, GTI looked for methods and processes that supported the SHRP 2 R01A goals. However, many of the projects researched provided little insight into a best-practices model because few of the projects had any 3-D utility features. Many of the projects were 2-D GIS mapping efforts, while several of the projects were conversion projects or standards development projects supporting conversion. One of the projects—GECCO in Tampa Bay, Florida—had several elements that were consistent with the SHRP 2 R01A goals, in that sharing data across several organizations was its primary focus, but the data being shared in the project were emergency management data.

The ROADIC project dealt with the issues of storing and retrieving data and methods for maintaining an ongoing record of the utility features. The ROADIC project was established to provide utility location data across both government and utility organizations. The system employed by ROADIC was originally developed in 1986 to track utility systems in Tokyo after natural gas explosions in the utility system. The ROADIC project was extended nationwide to include 12 other regions where the utility infrastructure served large population centers. ROADIC was

an interesting project to study as it emphasized the need to maintain an integrated view of all of the utilities in a highway right-of-way. The organization that operates and manages the ROADIC system has recorded significant benefits through improved coordination of construction activities and significant reduction in delays of large projects by reducing the number of unknown utility locations. One feature of ROADIC that was of particular interest was the permitting process. The ROADIC system provided universal access to the utility infrastructure when it came time to review the areas affected by a permit request. When ROADIC was used, turnaround time was dramatically reduced to just a few days from permit application to issue. Given ROADIC's success with the permitting process, GTI stressed the importance of modeling permits in the SHRP 2 R01A pilot system. The use of permits and their integration into the SHRP 2 R01A system is a key finding of this report.

The ROADIC project has a central data store that is used to control and maintain the utility features for the entire country. It was not apparent from the literature review whether ROADIC has 3-D utility data. ROADIC requires that all parties use the same editing and viewing tools when accessing data in the system. This mandated use of system tools that were declared a national standard in Japan is counter to the SHRP 2 R01A project. The R01A system data should be available to a variety of users within the DOT and permitting agencies. Unlike ROADIC, the data storage environment should be flexible enough to support multiple viewing and editing tool sets.

The literature review and telephone inquiries on the Alaskan Way Viaduct and Seawall Replacement (AWVSR) project proved interesting because a significant portion of its design was developed in 3-D. The use of 3-D design supported a variety of processes in the implementation of the project. The contractor, Parsons Brinckerhoff, created 3-D data during the project and used it with a variety of 3-D tools from Autodesk, Bentley, ESRI, and Leica for presentation and evaluation of different design alternatives, design of subsurface utilities, and earthwork and in support of other project activities. From the 3-D model, Parsons Brinckerhoff prepared a number of 3-D renderings used in the final design deliberations and produced a number of animations depicting the planned project.

As with most projects, the 3-D utility model was not available at the start of the AWVSR project; however, 3-D technology proved to be valuable for a number of project-related work activities. Information gathering on the AWVSR project pointed to the value of preserving the 3-D utility data for future projects.

The Enterprise GIS Phoenix Sky Harbor International Airport project was reviewed; however, nothing of relevance to the R01A project was discovered.

Several best practices in both the ROADIC and the AWVSR projects were considered for incorporation into SHRP 2 R01A. The ROADIC project has a central data store that is used to control and maintain the utility features across Japan. The

ROADIC program mandated that all parties use the same editing and viewing tools when accessing data in the system. Mandating the use of specific system tools (in this case, tools that were declared a national standard in Japan) is contradictory to the objectives of the SHRP 2 R01A project—and, regardless, such a mandate would be almost impossible to implement across all U.S. DOTs. Thus, the SHRP 2 R01A system should not be developed with any requirements for specific technology for viewing and editing the data. The system should be engineered in such a way that multiple groups working on the system with different tools can access the data. And the system should be defined with technology that is indifferent to the tool sets that connect and consume the data.

Several of the other projects reviewed occasionally produced 3-D designs to assist in some of their construction projects. Many of the 3-D designs were developed to support construction scheduling and to assist in visualization and construction logistics. Unfortunately, many of these projects are not preserving the record of the finished utilities and are ignoring elevation data when documenting as-built conditions. Of the 11 projects reviewed from the list above, only the AWVSR project was using full 3-D models of the underground utilities.

Few of the projects in this literature search had discussions on data quality grading as defined in ASCE 38. Some utilities have properly defined characteristics and documented locations certified by a professional engineer's seal, which is the preferred source of information for a project. However, a number of sources of utility location data are extremely valuable but were never classified using ASCE 38. Managing and understanding the difference between both sets of utility data are critical when designing and operating a system that will store both types of data. A common finding was that many of the projects allowed the maximum use of data with varying quality levels. There must be a means of defining the quality of the utility data. Once the data have a known quality, they may be used for design and construction within the limits of the quality designation. Storing data with a defined data quality level is the first step in setting up a new DOT project. According to numerous examples in the literature reviews, the SHRP 2 R01A system must provide a means of managing all ASCE 38 classifications, and all data being entered into the system must carry an ASCE 38 classification.

Papers Reviewed

In addition to the review of the eleven projects listed, GTI's literature review included several papers concerned with newer computing technologies for storing, retrieving, and using 3-D spatial data. The research focused on developing a solution that could be implemented completely independent of any mainstream CAD and GIS vendors.

At the time of the review, the technologies discussed in these papers represented a sampling of the latest thinking for

3-D data conversion, 3-D rendering, and 3-D data storage in an environment not tied to a specific software product. GTI considered this path for a solution for the storage, retrieval, and use of utility data with the fewest ties to any commercial software vendor's solutions.

Findings from Literature Search and Information Gathering

1. *The solution must contain an integrated view of all utilities in the right-of-way.* GTI's finding from the research is that all utilities and belowground infrastructure—regardless of the owner—should be included so that the view of the underground is inclusive and without exception.
2. *The solution must integrate permitting processes and permit status to define areas of change.* The permitting process must be integrated in a solution to ensure that there is a uniform means of capturing change to the DOT project right-of-way. Permitting processes are a unique opportunity for capturing utility engineering design information, utility construction status, and completion of utility final as-built conditions.
3. *The solution should be built on a single data storage environment.* The systems studied in the literature search all seemed to be constructed on a single data storage environment, holding all of the utilities in the DOT right-of-way. The data storage was controlled by a single entity and its security administration by a single entity. Several options for compositing utility information from individual utility data storage systems were considered, because this would have significant benefits for labor savings, but these options were dismissed because of concerns over control and data integrity. The quality of the utility information would be difficult to confirm and would not be viewed by the DOT as reliable.
4. *The solution should be architected with a data storage environment flexible enough to support multiple viewing and editing tools.* The choice of the data storage technology should not mandate a specific vendor's technology or software product. In several of the projects reviewed, different groups of people (engineering, construction, public relations, permitting) had different requirements for data access. The system's data storage technology must allow for different tools to satisfy a variety of users' needs. Complex design and engineering tools should be able to be used with the data, as well as with tools to produce public awareness presentations for community outreach and education.
5. *Organizations that use the solution may be required to re-design some of their workflows to optimize the systems value.* While the system must be flexible, new work processes and modifications to existing workflows will likely result from the adoption of the SHRP 2 R01A system architecture and recommendations. Attempting to fit the recommended system around existing organizational structures and work processes may reduce the effectiveness. Several of the projects researched discussed changes in both work processes and techniques for capturing ASCE 38 quality level A data. These changes occurred during and after the completion of a construction project and were viewed as key to providing high-quality data.
6. *The utility companies need to supply the locations and characteristics of each utility system or component that lies within the DOT right-of-way.* Specifications consistent with ASCE 38 for recording horizontal and vertical measurements must be developed and adopted for all utilities. All utility locations should be tied to a suitable coordinate system. Utility companies installing utility components, inside the DOT right-of-way, should fully define the utility (e.g., sizes, material type).
7. *Utility data must be stored with an ASCE 38 data quality rating.* All utility data loaded into the SHRP 2 R01A 3-D utility location data repository must have an ASCE 38 data quality level of A, B, C, or D. No utility data should be entered that are not categorized by quality level. All project managers would prefer to start a project with 100% of the utility data at quality level A. If 80% of the data for a project are classified as ASCE 38 quality level A and the balance as levels B–D, the project manager has 80% of the utility location investigation complete and can focus the investigating resources on 20% of the underground data. Concentrating only on utilities with lower quality levels is key to the project and fundamental to saving resources.
8. *Utility data locations must be obtained through direct measurement.* Development of as-built locations on utility installation postconstruction is often done by marking changes on design drawings (i.e., exception reporting). At the beginning of a project, utilities are given a design location on a set of design plans. Often, as-built locations of the utilities are established by marking up exceptions to the design location on these plans. The actual location could be different from the marked up drawing when construction exceptions are overlooked. Utility locations should be independently identified through direct measurement. Both the horizontal and vertical as-built locations of the utilities should be reported from direct measurement. Reporting by this means provides a definitive description of the location of the utility system.
9. *New technologies can improve future utility location mapping.* Going forward, newer technologies such as radio frequency identification (RFID) or other low-cost locational markers can provide an added accuracy check and help with postconstruction locating in the field. Permitting requirements may need to mandate the installation of low-cost electronic markers in the future, to take advantage of these new technologies. Utility purveyors are unlikely to do this voluntarily due to the increased cost.

CHAPTER 3

Solution Framework

With the literature search complete, the next step was to develop the framework of policies, processes, procedures, and systems to store, retrieve, and use 3-D utility location data in highway renewal projects. This chapter outlines the following:

- The approach and process used to develop the framework;
- The key challenges that were identified;
- The proposed framework and conceptual workflows; and
- Data and administrative considerations.

Approach and Process

In developing the framework, the project team used a combination of best practices identified in the literature search, technologies and protocols under development by both the project team and other organizations, novel ideas from the project team, and commercially available hardware and software. This approach allowed the project team to select the best possible combination of protocols, models, and technologies.

Workshop

Development of the final strategy began with GTI, TRB, and Bentley Systems attending a workshop held in January 2013. The goal of the workshop was to discuss the requirements of a 3-D utility model for a DOT project area that could

1. Support the utility and project design;
2. Store 3-D as-built utility data at the completion of a DOT project;
3. Maintain an ongoing 3-D record of utility data as changes are applied over time;
4. Define a proof-of-concept project that could be used to test the 3-D Utility Data Model; and
5. Define a pilot implementation within a production environment.

The workshop attendees agreed that one key element of a successful framework should be the integration of the 3-D Utility Data Model with existing business processes performed by DOTs. Every care should be taken to avoid creating a new database requirement that would require a new business process and therefore lead to higher production costs.

The attendees spent time during the workshop discussing the legacy data that are typically associated with a highway construction project. Legacy data processing provides a wealth of data. The framework needs to address how these data could be used to assemble an initial 3-D project utility model.

The attendees also discussed in significant detail the 3-D modeling requirements that they felt would aid in the design, construction, and recovery of utility infrastructure. This included a discussion on testing the effectiveness of distinguishing data quality (defined by ASCE 38-02 as quality level A, B, C, or D).

Key Challenges

The following bullets present the key challenges that were identified during the workshop.

- The project is intended to develop alternative strategies for acquiring 3-D utility location data and implementing a pilot project that includes a number of participating utilities within a defined geographic area.
- The project will provide a demonstration of the access control, data security, data source and quality level (based on the Standard Guideline for the Collection and Depiction of Existing Subsurface Utility Data, ASCE/CI 38-02), positioning uncertainty, available characterization data, and liability issues that would be faced in a full-scale implementation of the system.
- Ongoing database management issues, data ownership, and data sharing shall be discussed. Providing documented

examples of solutions to these administrative and legal issues is an important part of the project.

- The project should include implementation of positional and structural data capture involving the participating agency and the participating utilities for new utility installations and exposure of existing utilities, and the removal or updating of the status of those utilities that may have been relocated.
- The project shall include the pilot implementation of computerized utility data, maps, and models. This implementation will be used for locating and characterizing utilities for design purposes, as well as for damage prevention in excavation or construction projects. Existing laws and best practices regarding utility damage prevention should be followed. The advantages and disadvantages of the proposed approaches should be recorded.

As a result of the workshop, a conceptual workflow was defined. This workflow included the following:

- Registering legacy utility data (mostly from 2-D sources);
- Creating an engineers' repository;
- Processing site data with traditional CAD and GIS tools;
- Generating 3-D utility models from existing legacy content; and
- Storing all utility content in an open 3-D utility model based on Oracle Spatial (discussed in more detail in Chapter 4).

Proposed Framework and Conceptual Workflow

To provide context to support an understanding of the system architecture and administrative processes, the conceptual workflow is described below. The workflow describes how data are initially captured for a project and moved through the subsequent processes of design and maintenance of the project area, continuing through to project closeout. Each process is intended to ensure that the system has a high level of data integrity and is kept current. The high-level workflow contains 14 key activities as listed below. Following the key activities list, graphical displays and summaries for four data input use cases are provided to add clarity and detail to these high-level workflow descriptions.

1. The DOT creates a project boundary definition (narrative) in the content management system and, most important, in the 3-D utility storage system. The project boundary is created in 2-D geometry but is still stored inside the 3-D utility storage system. The project boundary is created and stored as a polygon feature.
2. The DOT appoints a utility data analyst for the project who is responsible for all data and data changes in the system. This role is given the name *Gatekeeper*, which will be used throughout this document.
3. The DOT provides utility feature definitions and layering standards for 2-D and 3-D CAD data and ASCE 38 data quality level requirements to the person/organization responsible for developing a base condition record of utility infrastructure locations. This work of acquiring the field utility information is usually performed by a DOT contractor, such as an engineering company or subsurface utility engineering (SUE) firm. Additional utility information may come directly from a utility or government agency responsible for utilities.
4. The base conditions of the project site can be captured through utility records, field surveys, and other data sources. Much of the data is submitted in electronic files in CAD or GIS formats. Additional data in the form of images (raster scans of paper documents), PDF files, and raw data from various scanning and locating technologies may also be submitted for reference purposes and saved in offline storage in the content management system.
5. Utility files of CAD data submitted from the engineering, SUE vendor, or subcontractors are submitted to the Gatekeeper for loading into the content management system. Background data such as utility records, drawings, photos, and other background information are also submitted to the Gatekeeper to be included in the content management system as supporting information.
6. All underground utility work requires the issuance of a right-of-way (ROW) permit. The ROW permit must be obtained by the entities performing construction work before the start of a project. The boundary of the ROW permit defines the area of construction where the location and/or status of utility structures will be changed. During the permit application process, the DOT provides the utility company with specific documentation requirements for design and as-built files. The utility company must acknowledge these requirements. Each permit must be monitored to ensure that the required submittals are delivered to the DOT consistent with permit requirements.
7. Permits to proceed with work should be issued contingent on the satisfactory submittal of designs consistent with permit documentation requirements. Permit applications for new work may be accepted contingent on the utility company's compliance with submitting as-built documentation on prior projects for which construction permits have been issued.
8. In those states where ROW permits are not directly controlled by the DOT, the DOT provides specifications for data submittal for incorporation into local or state permitting agency protocols. The specifications address spatial accuracy, data quality, and utility feature data definition.

9. As part of the as-built documentation process, smart tags (such as RFID ball markers) should be installed by the permittee/utility contractor during the construction process in accordance with the DOT's applicable policies to facilitate the relocation of utilities in the future.
10. During the project and after its completion, the Gatekeeper retains all documents that record changes to underground utility locations. Each record should be linked to an ROW permit or other administrative change to document the polygon features.
11. Excavation and utility work occurring within the project boundary during the project or after its completion is identified through the permit process and the One-Call system. If suitable land-based features exist that can be easily identified on aerial photography, during or after the DOT project, digitizing the One-Call ticket boundary is a recommended means of establishing a One-Call ticket polygon. One-Call polygon boundaries provide a means of checking, validating, and ensuring that an ROW permit was issued and that the proper documentation was submitted and approved. Permit application boundaries without proper approvals can create warning notifications to the DOT Gatekeeper, alerting him or her that the system is missing critical documentation to maintain proper control of changes to the underground utility features. Measures must be taken to ensure that no physical changes are made in the utility underground without the proper documentation.
12. The Gatekeeper monitors One-Call tickets submitted within the DOT project boundary to identify excavation work. If excavation activity is detected that does not have the appropriate ROW permit, the DOT can contact the excavation contractor and/or utility company to require submittal of the appropriate permit application.
13. Utility companies collect location data according to the DOT requirements on newly installed or relocated facilities.
14. The Gatekeeper reviews the data submitted by the utility company and enters them into the content management system. Once the changes are made, the ROW permit polygon's status is updated to show that utility and other underground features have been updated in the content management system. With this status change the source documents are used to build the 3-D geometry in the CAD environment, and the model builder is used to build, extract, and insert the 3-D utility features into the 3-D utility storage system.

Data Input Use Cases

Highway right-of-way 3-D utility location data can originate from the DOT, a DOT contractor (or SUE firm), or a utility

company. For the purposes of process modeling, two data input use cases for a DOT project have been developed and are described below.

Base Conditions

The input data contain the original utility data collected to start the design phase of the project. The scope of the base conditions should clearly identify any utilities that are omitted from the base condition (e.g., residential service lines or underground street light circuits).

The steps involved in base conditions data capture are as follows (see Figure 3.1):

1. DOT creates project.
2. DOT creates project boundary polygon(s).
3. DOT requests data from all utility companies (check in to content manager).
4. DOT requests utility data from existing project area data stores (check in to content manager).
5. DOT requests all permits issued for work in the project boundary (check in to content manager).
6. DOT classifies all records received in Steps 3, 4, and 5 according to ASCE 38.
7. DOT Gatekeeper verifies data classifications and releases for 3-D conversion.
8. DOT creates 3-D models of utility systems inside the project boundary.
9. DOT develops a list of those areas where the ASCE 38 classification dictates more investigation.
10. DOT Gatekeeper receives utility data submittals from investigation processes defined in Step 9 above and loads them into the content manager as field investigation and data collection progress (3-D data are loaded directly into 3-D storage, 2-D data are converted to 3-D and uploaded to 3-D storage system).
11. Design may proceed in areas not designated as under investigation in Step 9.

Non-Project-Related Changes

For this use case, data are submitted by the utility company for any work that results in a change in status or location of utility lines within the project boundary but is not directly related to the DOT project.

The steps involved in non-project-related changes in data capture are as follows (see Figure 3.2):

1. DOT receives ROW permit request from utility company (*permit pending*).
2. DOT issues permit and data requirements to utility company (data accuracy, ASCE 38) (*permit issued*).

(text continues on page 15)

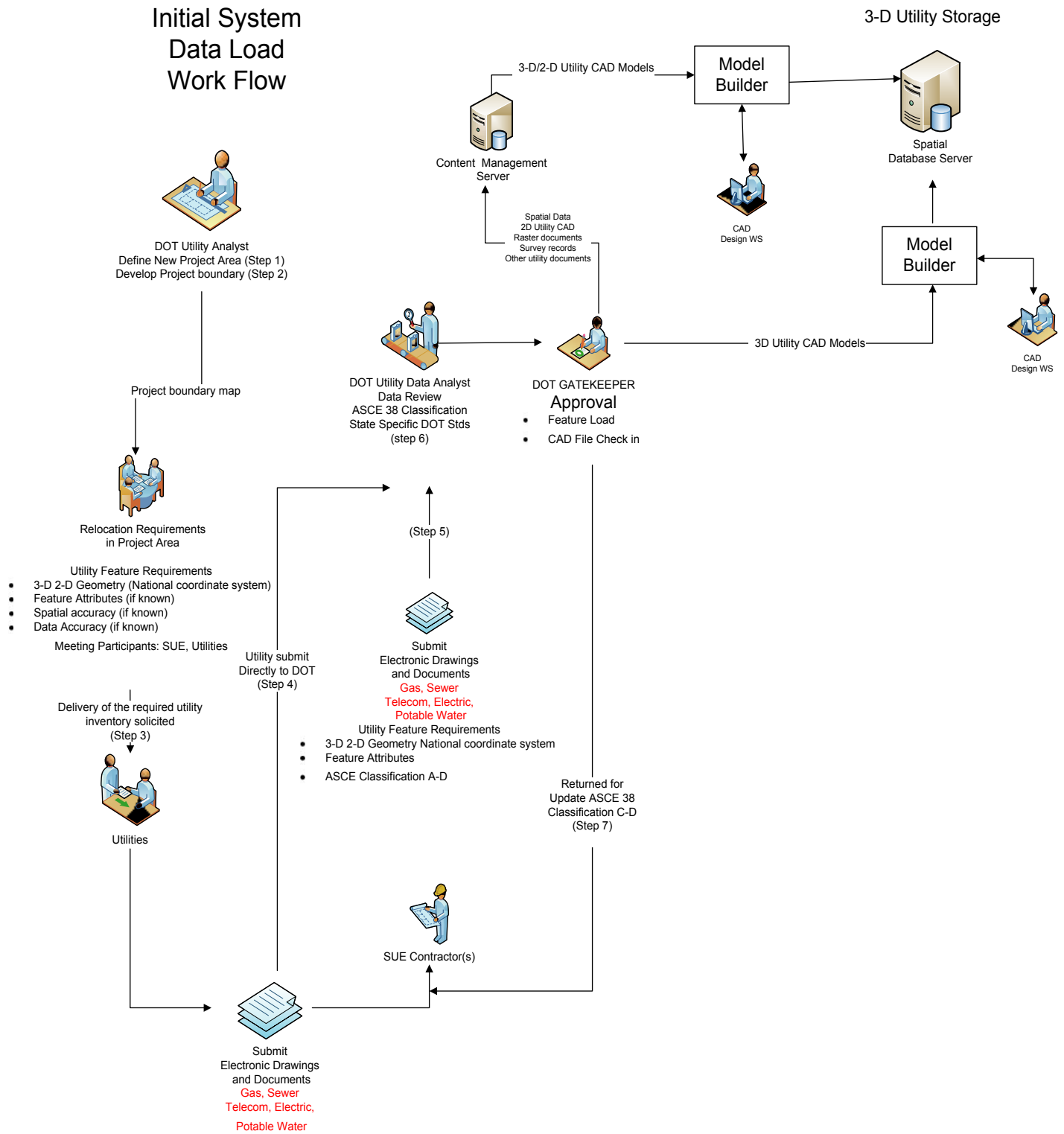

Figure 3.1. Initial system data load workflow.

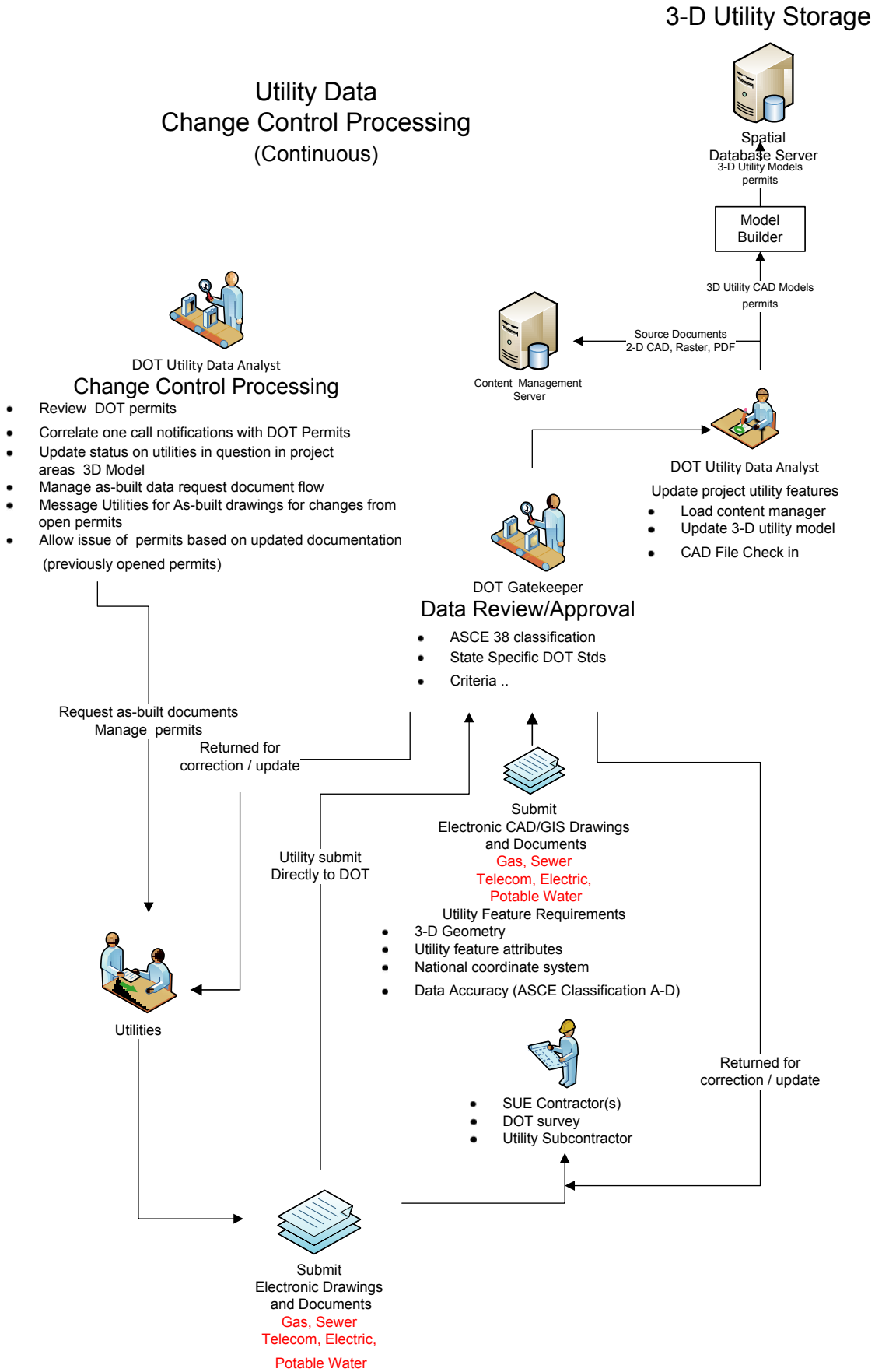

Figure 3.2. Utility data change control processing.

3. Utility company submits a One-Call ticket request.
4. The system determines if the excavation area defined by the One-Call ticket is within the boundary of a DOT project. If overlap occurs, the system supervisory applications verify submittal status on an ROW permit and issue a status message to the DOT Gatekeeper if the One-Call ticket is in an area without an ROW permit.
5. If there is an ROW permit, the system changes the status on the ROW permit when the One-Call mark-out order is issued (*construction*). The content manager defaults to a second status (*waiting for as-built*).
6. Utility owner relocates facility and collects and transmits as-built data according to ROW permit instructions.
7. Gatekeeper reviews as-built information, checks the information in to the content manager, and updates the ROW permit status. Then, the system automatically sets a third status on the ROW permit as *3-D updates pending* or *built per design*.
8. Engineering updates the 3-D model per as-built documents and sets final permit status (*permit closed*).
9. Gatekeeper verifies changes to the system.

Data and Administrative Issues

A number of data and administrative issues need to be considered and addressed when the 3-D utility model is initially developed and as it is maintained for long-term use.

Data Collection

The framework is based on the premise that the DOT creates an initial 3-D utility model by loading source data, utility spatial files, utility design files, reports, sketches, and raster representations of utility locations into the content manager for conversion. There is no assumption that the data are complete or reliable. Instead the available data are loaded into the content manager and characterized by quality levels. The intent is to create a mosaic of utility features that can be updated and refined over time. Certain utilities may not be captured at all during creation of a project's base map. These might include street lighting, signage, traffic control loops, and residential services. As such, it is critical that the initial project definition contain metadata that clearly indicate any utility information that is unconfirmed or missing from the initial 3-D model.

The base utility map will likely be composed of both 2-D and 3-D representations of underground utilities with the appropriate ASCE 38 quality level. By loading the data in all of their various states of quality, a baseline is set that allows the DOT to focus its efforts on verification of incomplete data or data of unknown quality. This eliminates the expenditure of funds for validating data that are known to be accurate. The

process of developing this mosaic of different quality level data also allows for the development of work plans targeted at updating the most important data. All utility data must be classified according to ASCE 38 when loaded into the content management system. Data received that are not classified according to ASCE 38 will be classified as *unknown quality*. All data that are loaded in this manner shall be characterized through notation of the means and basis under which they were collected. This characterization will be recorded in a note field accompanying the data as they are filed in the content management system. In the event that the information has no geographic location data, the document will initially be associated with an area defined by the DOT project boundary.

A primary objective is to create utility features that are reliable for design purposes from the various base map data sources. This process is critical so that all of the data loaded at the beginning of the project can be used to determine which data are in need of updating and further field investigation. The overall goal is to provide as much high-quality data to designers at the beginning of the project as possible to reduce the amount of new data that must be collected.

Utilities with underground facilities whose location stays constant but undergoes a status change should provide an update of this information to the DOT. Abandoned facilities are a good example of such a requirement covered under this condition.

Field Data Collection

When new underground construction is performed through an open trench, the permitting processes should mandate collection of both horizontal and vertical utility data. Utility locations should not be reported relative to local landmarks but should be recorded based on a national coordinate system. Spot checks of horizontal and vertical utility locations in the field through excavation, as well as surface geophysical techniques, should be used to upgrade quality level classifications in accordance with ASCE 38-02 Standard Guideline for the Collection and Depiction of Existing Subsurface Utility Data.

Utilities that are directionally drilled have the same quality level requirements. During drilling operations, the drill head should be tracked with aboveground locating equipment.

Many locating and data capture technologies for utilities can produce vast quantities of raw data that have limited direct value for permanent storage. If the raw data are deemed important and the file size is reasonable, the data can be stored in the content management system. If the data set is very large, such as the data resulting from any laser scanning technologies, it is recommended that the data be housed in an offline storage system. References to the location of this storage should be catalogued in the system for future use. Online storage of raw data cannot be accommodated in the 3-D model.

The installation of smart tag markers on newly constructed utilities should be seriously considered for all future installations. For example, VDOT requires that RFID ball markers be installed at a frequency ranging from 25 feet to 50 feet, depending on the level of congestion, along utility lines as they are exposed. Additionally, smart tag markers should be installed in any excavation, such as test holes, performed during the initial data validation and design phase. The location and identification of the markers can be added to the utility spatial database as RFID locating features. These markers will provide an enhanced utility location verification tool during the design and construction phase of future projects. The markers provide a quick way to verify existing utility features without excavation and can reduce the occurrence of excavation damage and its consequences.

GTI has developed a GPS-based technology in other research projects that can be used to record the locations of utility features with high levels of spatial accuracy and precision. This technology could be deployed during a DOT construction project, providing a means of recording new utility installations and updating and/or correcting existing utility locations in real time. The system is unique in that it allows for the precise updating of utility features that are housed in a geospatial environment without any back-office processing.

Data Quality and Accuracy Standards

Implementing quality and accuracy standards is an important part of ensuring the integrity and reliability of the system. The DOT provides data accuracy and quality level requirements for each project. The DOT may specify different accuracy and quality level requirements for different utility types. For example, the DOT may require a higher level of accuracy for positional data of critical utilities, such as transmission facilities and communications cables that are dedicated to vital services. ASCE 38 should be used as the data quality standard.

It is worth noting that ASCE 38 is not an accuracy standard but is instead an accountability standard that requires a professional's seal. This seal indicates that all data were collected under the responsible charge of that professional and that judgment was then used to assign a quality level—A, B, C, or D. There is no universal agreement or compliance with these standards in the industry to date, and the definitions are subject to change. It is therefore important to store the date, method of collection, and other information recorded in the field related to data quality.

One requirement of the system is that it facilitate the viewing of data by quality levels. Quality level designation enables designers to distinguish between different accuracies and differences between horizontal and vertical measurements. This applies to 2-D and 3-D representations of the data.

All utility location data that are loaded into the 3-D utility model must be consistent with the project datum and coordinate system. Data that are received with a different datum and coordinate system must be converted before incorporation into the 3-D utility storage system. If the data are submitted by an outside agency and are not consistent with the datum and project coordinate system, the data must be submitted with metadata clearly defining the datum and coordinate system used. Information must be recorded in the metadata of any spatial data using NSDI FGDC-STD-001 CSDGM. If the data are in CAD format, the datum and coordinate system must be incorporated into the attribute data describing the files that are included in the content management system. Data created specifically for the project (engineering designs) must be consistent with the datum and coordinate systems specified by the DOT.

Quality Assurance and Quality Control

For purposes of this project, *quality assurance* is defined as the oversight of processes and organizations responsible for implementing and maintaining proper quality control of the data, the systems used to process the data, and organizations that create data. Quality control processes are used to ensure that the required standards and specifications are met in the creation and collection of data required for a project. It is recommended that sampling plans consistent with NSDI FGDC-STD-007.3 be implemented to measure and quantify data accuracy. This sampling process, which produces utility location data certified to a quality standard, is a primary quality control function. Data delivered to the DOT for the intended use of upgrading the quality levels of a set of utility features stored in the system must meet the certification requirement of ASCE 38.

It is recognized that some data may be loaded into the system that has not been certified to ASCE 38. When data that are not certified to ASCE 38 are loaded into the system, this condition must be noted. The system should have a status defining *no ASCE 38 classification*. Data loaded into the system in this condition serve as a starting point for additional field investigation work.

According to SUE practices, data quality validation and certification are accomplished by sign-off on all work submitted to the DOT by a registered professional engineer. Production projects should use this practice as much as possible by having an approval step before any utility data are loaded into the content management system or the 3-D storage. The Gatekeeper will look for evidence that the data are certified to a given quality level by a registered professional. Source documents such as CAD models, images of paper drawings, and any other electronic documents added to the content management system should be classified with the appropriate quality

level noted on the metadata associated with each record filed in the system.

In the context of the SHRP 2 R01A project, quality control tasks are performed before the data are entered into the system. The project team envisions that these policies will be established by the users of and contributors to the system. A critical requirement of any system used to track change is a process to ensure and maintain data quality. Unknown, poor, or incomplete data can result in a system with limited value.

The Gatekeeper is responsible for monitoring and approving all data flows into the system. Responsibility for all data flows into the system does not necessarily suggest that data cannot be loaded by multiple individuals or organizations, but it does suggest that versioning and revision control of data is the sole responsibility of the Gatekeeper. Specifically, the Gatekeeper is responsible for identifying suspect data, selecting the more accurate and reliable data when conflicting data are submitted, promoting and demoting data, requesting additional or more reliable data, adding missing data, and assuring quality designation of submitted data.

Data collected by any means are candidates for inclusion into the system. The Gatekeeper reviews all data, including the metadata. When the accuracy of the data being submitted is unknown, this condition is noted in the metadata, and the data quality grading is adjusted accordingly.

The Gatekeeper has the authority to incorporate data submitted from other stakeholders into the permanent record after the appropriate review. The Gatekeeper is responsible for ensuring the most current information is available in the system, reflecting the best-known underground utility information for the project area. Updates to the 3-D storage are the responsibility of the DOT engineering and design departments; the Gatekeeper primarily serves a control and audit function.

The Gatekeeper is responsible for system monitoring to ensure that the change control features (permits) status is accurate and that the underlying documentation reflecting changes in the project area is consistent with the changes that have taken place in the field. At a minimum, if there are changes in the project area, the Gatekeeper is responsible for ensuring the system reflects changes even if the system lacks details of the changes. This will be a common condition since

human interaction with the system is part of the process flow. The system is designed to define the areas where change has taken place so that the underground exploration and definition activities can be focused on areas requiring more detail.

Security and Access Controls

Since this system is operated primarily for the management of the DOT right-of-way, the security and access controls should be managed by each state DOT. All modifications and additions of data should be within the strict control of the DOT and follow internal security and access control protocols. Utilities would benefit from read access to the data, but read access should be limited geospatially to an area of limited size. Organizations that issue permits should also be granted read access to the 3-D utility store and write access so they can spatially define the limits of the permit areas. The Gatekeeper should be the only person authorized to provide access to files or spatial data for modification within the system.

Access to the data should only be granted to authenticated users who are defined by roles whose definitions are controlled by the Gatekeeper. Given the sensitive nature of some of the data, background checks might be considered before granting access to the data.

Permitting

The ROW permit process is the mechanism used to communicate and ensure compliance regarding data submittal requirements. At a minimum, the submission of data during the permit application must address both horizontal and vertical locations of any modifications of utility infrastructure within the project boundary. The permit must include language requiring drawings that reflect as-built conditions for each permit issued, showing where the utility facilities are moved or created in the project area. Additionally, the system must register and track the location and status of each permit by the requesting utility and track the identity of the permit requestor. This tracking is needed to ensure that on subsequent permit requests the person or agency requesting a new permit has no outstanding permits for which the required as-built drawings have not been submitted.

CHAPTER 4

3-D Data Model and Data Repository

In preparation for the pilot stage of the R01A project, a 3-D utility data repository was created in an Oracle database using a 3-D Utility Data Model developed by the project team. The model is meant to represent the selected properties to be stored on 3-D utility data features. These properties have been designed to serve multiple purposes in a single data/object model. The two primary uses focused on were the following:

1. Decision making and planning functions: Conflict determination, permit management, and planning assessments.
2. Design/analysis functions: Utility conflict resolution, site utility redesign, and new site planning and layout design.

To facilitate industry use across multiple-vendor highway-design software environments, no proprietary data model geometry or objects were stored in the 3-D utility model.

Data Model Organization

The existing Spatial Data Standards for Facilities, Infrastructure, and Environment (SDSFIE) Department of Defense data model (Version 3.0) was taken as a starting reference point for the SHRP 2 consolidated Utility Data Model to ensure a consistent and grounded foundation that is in accepted use. Key utility and site features were extracted from the SDSFIE data model to form the foundational base for the model. With a focus on the utility features in mind, relevant attributes identified during the initial Integration Definition (IDEF) planning sessions that would be applicable in an underground utility data model operations framework were added—for example, *utility owner* and *(ASCE) quality*. Key properties necessary to define or build intelligent civil design objects were added—for example, *pipe diameter* and *material*.

In addition to those features and properties that define the utility data model, it was decided over the course of

development that the complete utility model should also include selective ancillary and auxiliary model features. These features supplement and provide contextual information relevant in servicing subsurface utility engineering use cases. The inclusion of the non-utility-feature information is evidence that no single data model can seek to cover any and all applications and use cases. Thus, the model will ultimately be adapted and extended such that it can be appropriately and specifically targeted for various purposes by adopting agencies. Inclusion of these additional elements is not intended to expand the application arena and is not intended to define the boundary of information that might directly or indirectly pertain to modeling subsurface utility engineering features and use cases.

Based on project assessments and meetings, the utility feature properties were classified into four categories:

1. General properties;
2. Utility-specific properties;
3. Data relationships, quality, and conflict resolution properties; and
4. Civil design-specific properties.

Figure 4.1 outlines the general organization for a subset of properties. The data schema—including tables by category (public works features, planning support features, and site support features), entity-relationship diagrams (ERDs), and domain values—are provided in Appendix A.

Reproducing the Prototype 3-D Utility Data Repository

On completion of the data model for the prototype, the project created the deliverables needed for future reproduction of the data repository. These were a relational model created by reverse engineering the physical model and two methods for setting up the prototype database.

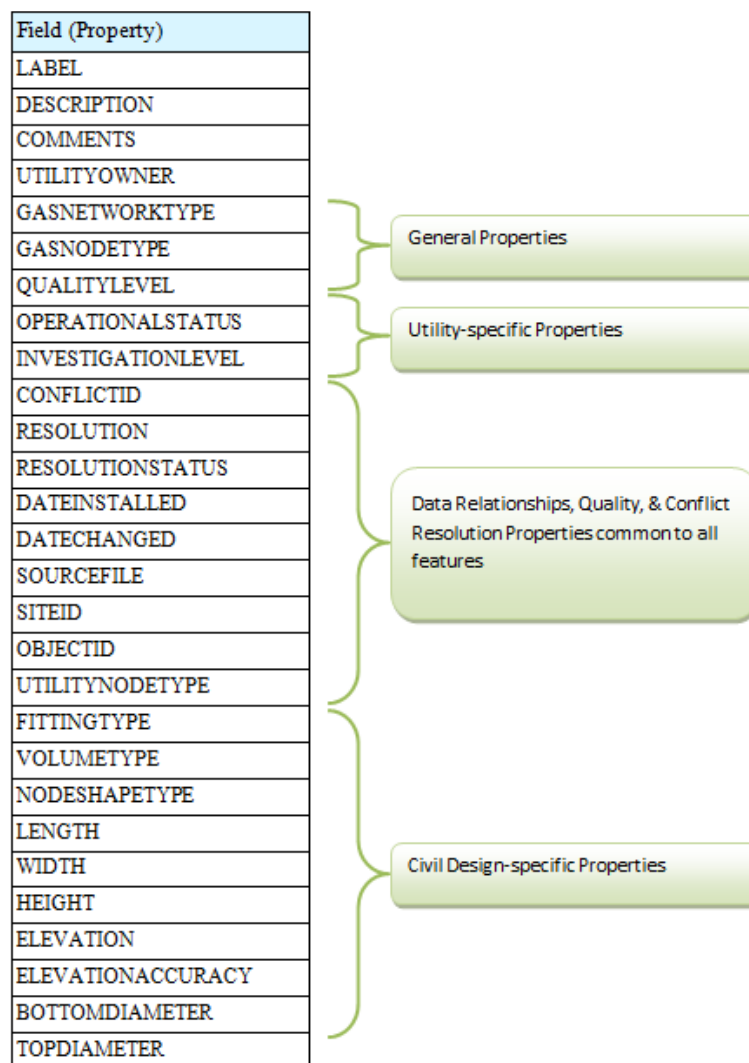

Figure 4.1. Typical organization for subset of properties.

Relational Model

The Oracle SQL Developer Data Modeler is a standalone application used for designing and translating entity, relational, and physical data models. For the SHRP 2 project, Data Modeler was used to reverse engineer the relational model from the physical model (final Oracle Spatial database) for creation of data definition language (DDL) scripts. The DDL scripts are provided in Appendix B. Once the DDL scripts were created, the relational model served as a base for feature and domain table documentation and diagrams. The steps (1–7) listed below are for recreating a graphic view of the SHRP 2 schema documentation used to develop the SHRP 2 3-D model.

1. Extract the Data Modeler files from SHRP2 Schema-Oracle Data Modeler.zip (available at <http://www.trb.org/Main/Blurbs/171927>).
2. Oracle SQL Developer Data Modeler is available for various platforms. Download it from <http://www.oracle.com/technetwork/developer-tools/datamodeler/overview/index.html>. Note that a free Oracle Web account is required for downloads.
3. Once downloaded, uncompress the zip archive, and run `datamodeler.exe` (32 bit) or `datamodeler64.exe` (64 bit).
4. Select File -> Open from the application's main menu, and then locate and open SHRP2 Schema-Oracle.dmd, extracted earlier.
5. In the left browser panel, expand Relational Models and then SHRP2.
6. The Tables node contains feature and domain tables:
 - a. Expand a table node to view fields, indexes, keys, and constraints.
 - b. Double-click a table or field node to display its properties.

7. The SubViews node contains tables with their foreign-key relations:
 - a. Expand a subview node to view related tables and foreign-key relations.
 - b. Right-click a subview and select Show Diagram to display that table's ERD.

Database Setup

Two methods for setting up the developmental prototype 3-D Utility Data Model Oracle database are provided. Oracle DDL scripts provide a human readable export of the Oracle schema that can be directly modified before importing if desired. Oracle Data Pump exports for the prototype Oracle database are also provided. Methods for pulling the DDL or exports are outlined below.

DDL Scripts

Oracle DDL scripts are provided as two files in SHRP2 DDL Scripts.zip (available at <http://www.trb.org/Main/Blurbs/171927>). The first file, SHRP2-DDL-NoData.sql, creates the database tables, constraints, sequences, and triggers needed to set up an Oracle environment. The second file, SHRP2-DDL-DomainValues.sql, inserts all necessary domain data values used during the GTI SHRP 2 project development and testing. The DDL scripts can be loaded either through Oracle SQL

Developer or from the command line using Oracle SQL*Plus. To execute the scripts using Oracle SQL*Plus, open a new Windows command prompt, navigate to the directory containing the DDL files, and then run the following commands:

- Oracle SQL*Plus username/password @ "SHRP2-DDL-NoData.sql"
- Oracle SQL*Plus username/password @ "SHRP2-DDL-DomainValues.sql"

Oracle Data Pump

Included in SHRP2 Oracle Exports.zip (available at <http://www.trb.org/Main/Blurbs/171927>) are Oracle Data Pump exports with an empty 3-D Utility Data Model Oracle environment. The export file was generated using Oracle's expdp command line utility in the following manner:

```
expdp system/password@dbservice SCHEMAS=GIS
DIRECTORY=data_pump_dir DUMPFILE=shrp2_export
.dmp LOGFILE=shrp2_export.log
```

The export file can be imported using Oracle's impdp command line tool. Copy the export file into the default Data Pump directory on the destination Oracle server. A custom directory can be used, but ensure a corresponding Oracle directory object is created.

CHAPTER 5

Proof-of-Concept Pilot Demonstration

With the 3-D model and schema defined, a proof-of-concept pilot demonstration of the 3-D model was executed using site information from an existing Virginia Department of Transportation (VDOT) project on Gallows Road in Fairfax County.

The proof-of-concept system consisted of the spatial repository, containing multiple features modeling utility infrastructure (such as potable water, sanitary sewer, storm sewer, electric, gas, or telecommunications infrastructure). The system was designed to employ the unifying technology of a spatially enabled document management system that serves as the staging repository for all project documentation and design models, including 3-D models, 2-D CAD files, specifications, image-based documents, and any other types of data required for a description of the project site.

Although software products from other vendors (including Autodesk, Trimble, and Intergraph) could have been used, the project team decided to use a Bentley suite of software products for the proof-of-concept pilot demonstration. Bentley products are commonly used by state transportation agencies for highway-design work.

The design team conducted a thorough analysis and review of legacy data associated with a recently completed VDOT project area at the interchange of Route 29 and Gallows Road in Northern Virginia. Before the proof-of-concept and pilot system development, many discussions were held with VDOT staff to understand the data creation process, accuracy, and new utility location techniques using RFID ball markers. A number of discussions addressed the needs of engineers who deal with the many legacy data types during the design phase of projects and the challenges they face in locating and retrieving content for their projects.

As a result of these discussions and analysis, the pilot team assembled a notional workflow for the proof-of-concept demonstration that included five major activities. These activities are representational and may or may not correspond to the actual utility practice at a state DOT. Figure 5.1 presents the five major activities that would be tested during the pilot.

System and Process

Architectural Diagram Overview

The server environment is designed to manage the 3-D Utility Data Model and all supporting engineering content (see Figure 5.2). Oracle Database 11g Release 2 (11g R2) was used for storing the 3-D Utility Data Model. Bentley Geo Web Publisher allows for a live view of the data model from a web mapping perspective. Bentley ProjectWise Geospatial Server manages the project and engineering-based content that is not stored within the database.

A desktop or thick client environment contains tools for editing, reviewing, and managing the 3-D Utility Data Model throughout the project life cycle and engineering workflows. Web clients can also take advantage of the mapping view of the 3-D Utility Data Model for project and engineering planning and review.

Software Loading Procedures

On the servers, Oracle 11g R2 was first installed on a Windows 2008 R2 virtual server. Installation was accomplished by using standard out-of-the box procedures to ensure a compliant installation. The 3-D utility data repository was reproduced in the empty Oracle database using the methods discussed in the Chapter 4 section Reproducing the Prototype 3-D Utility Data Repository.

Once the 3-D data repository was reproduced, the next step was to create tablespace, called GTIGIS to match the prototype environment. This can be accomplished in Oracle SQL*Plus using CREATE TABLESPACE as follows, adjusting the DATAFILE, SIZE, and other parameters as needed:

```
CREATE TABLESPACE GTIGIS DATAFILE 'D:\Oracle\shrp2.dbf' SIZE 100M AUTOEXTEND ON;
```

To take full advantage of spatial capabilities, while supporting 3-D geometry to and from engineering environments, a

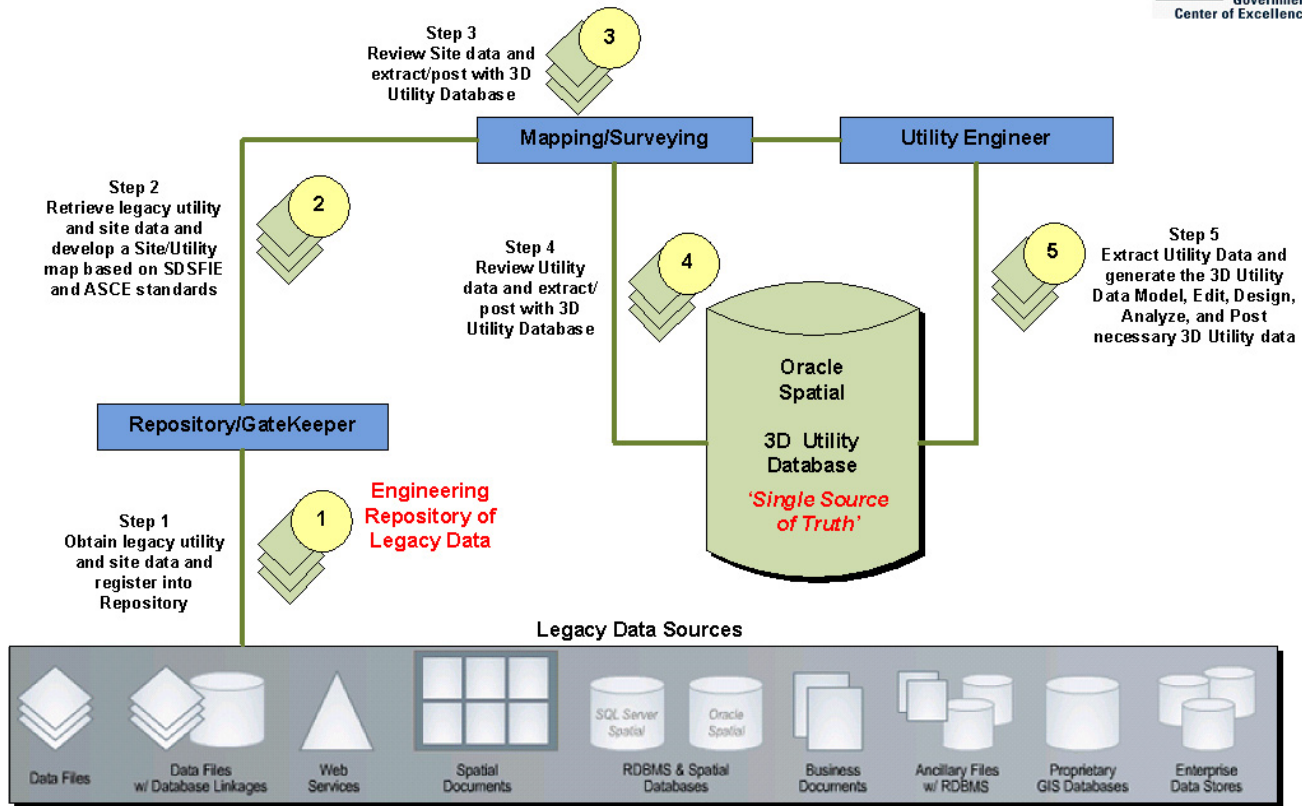

Source: Bentley Systems.

Figure 5.1. Diagram of five activities tested in the pilot program.

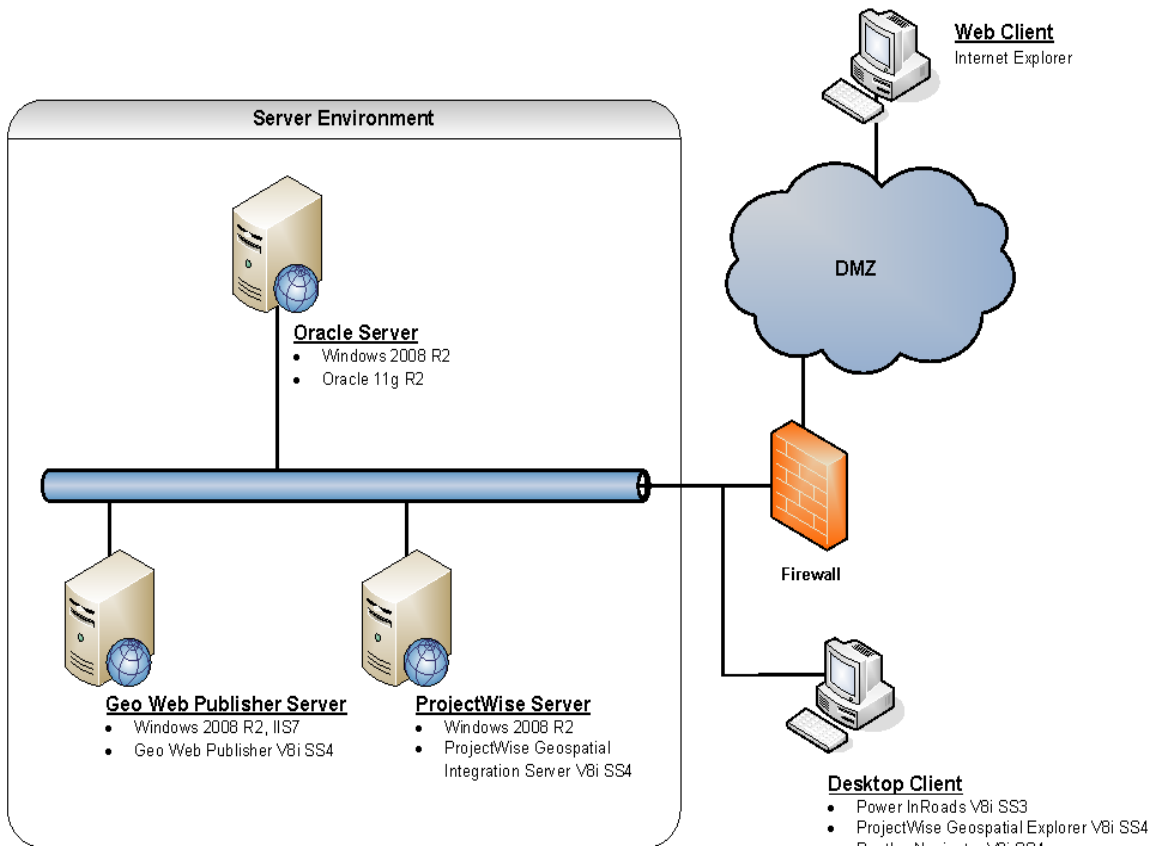

Figure 5.2. Architectural overview.

custom compound coordinate system was used for the pilot project area. This compound coordinate system combines a geographic 2-D coordinate system, NAD83(HARN)/Virginia North (ftUS), with a standard Oracle gravity-related height coordinate system. The resulting coordinate system was given a Spatial Reference System Identifier (SRID) of 9989. Before importing the prototype exports, create the compound coordinate system reference in Oracle Spatial from Oracle SQL*Plus using the following script (line breaks are added here for clarity):

```
INSERT INTO MDSYS.SDO_COORD_REF_SYSTEM (
  SRID, COORD_REF_SYS_NAME,
  COORD_REF_SYS_KIND,
  COORD_SYS_ID,
  DATUM_ID,
  SOURCE_GEOG_SRID,
  PROJECTION_CONV_ID,
  CMPD_HORIZ_SRID,
  CMPD_VERT_SRID,
  INFORMATION_SOURCE,
  DATA_SOURCE,
  IS_LEGACY,
  LEGACY_CODE,
  LEGACY_WKTEXT,
  LEGACY_CS_BOUNDS)
VALUES (
  9989,
  'NAD83(HARN) / Virginia North (ftUS)',
  'COMPOUND',
  NULL,
  NULL,
  NULL,
  NULL,
  2924,
  5701,
  NULL,
  'EPSG',
  'FALSE',
  NULL,
  NULL,
  NULL);
```

Once the 3-D utility database loaded in Oracle Spatial has the necessary tablespace and coordinate system, the data dump export can be loaded. From a command prompt, run the following:

```
impdp system/password@dbservice SCHEMAS=GIS
DIRECTORY=data_pump_dir DUMPFILE=shrp2_export
.dmp TABLE_EXISTS_ACTION=REPLACE LOGFILE=shrp2_
import.log
```

Replace *password* with your Oracle system account password, and replace *dbservice* with the destination service name. Once

the import operation is complete, the final database tables and supporting objects are now in place.

Bentley ProjectWise Geospatial Integration Server SS4 was installed on a separate Windows 2008 R2 server. The installation of Bentley ProjectWise followed out-of-the box procedures, ensuring a standard compliant installation. Bentley Geo Web Publisher V8i SS4 was installed on a third Windows 2008 R2 virtual server. Though the tools used for this project's purposes were Bentley software tools, another vendor's products having highway-design capabilities (such as those of Autodesk, Trimble, or Intergraph) can be substituted.

On the desktop clients, several pieces of software were installed to properly manage the 3-D Utility Data Model. To edit the model, the latest release of Bentley Power InRoads V8i SS3 and a soon-to-be released version of Bentley's Sub-surface Utilities Design and Analysis were included. Again, other leading highway-design software vendor's products can be used for the processes conducted in the pilot.

To manage the model's supporting engineering content, Bentley ProjectWise Geospatial Explorer V8i SS4 was also installed. Internet Explorer, with the Bentley Geo Web Publisher ActiveX control, was used to view the model from a planning/web perspective.

In summary,

- Content management solution: Spatially enabled document management system (Bentley ProjectWise Geospatial Server).
- Content manipulation solution: 3-D highway-design CAD software (Bentley Power InRoads Subsurface Utilities Design and Analysis).
- Content review solution: Web-based geospatial viewer plugin (Internet Explorer with Bentley Geo Web Publisher).

Working with the Model

The 3-D Utility Data Model was housed within an Oracle Spatial database that supports 3-D storage of points, lines, and polygons. Bentley OpenRoads 3-D civil platform was connected to the model's specialized application layer for 3-D modeling in which the working set of utility objects can be manipulated (individual instances created, updated, deleted, and inspected) with civil design tools and then posted back into the repository (see Figure 5.3).

3-D Model Testing Procedures

The first step was to load the legacy data into a content management solution, ensuring that all relevant project content was available. All content that is loaded, whether it is an Adobe PDF, Microsoft Word document, or any other format, can be associated with geospatial locations. This step is necessary to

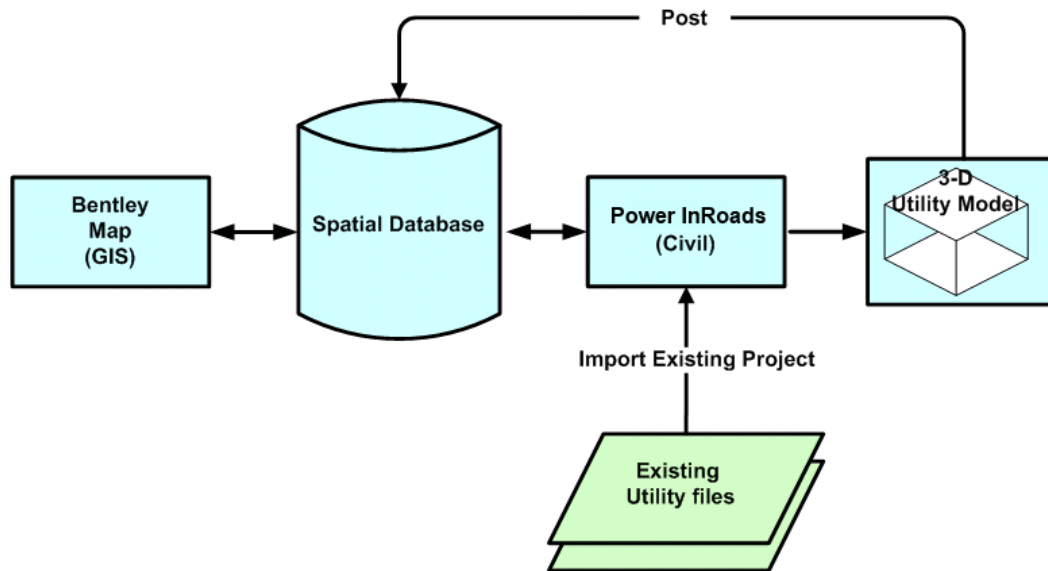

Figure 5.3. 3-D model workflow.

ensure that all of the available data are properly staged and managed for processing into the 3-D model. Any document management system that can be enabled with spatial indexing is suitable for this task. Document management systems without spatial indexing can also be used provided a suitable set of indexes is applied to the documents that are stored and the system supports a state management process, such as revision control or release management.

Figure 5.4 shows not only the folder location of a source marker ball PDF but also the geospatial location of that file and a preview of its contents.

The second step was to build the intelligent 3-D model (i.e., the spatial database with the individual feature definitions and properties that give the features intelligence). Once all the content was loaded into the content management solution, a 3-D design tool, Bentley Power InRoads, was used to model the site in 3-D. Other CAD vendor packages are capable of similar editing functions and can be configured to create the same 3-D CAD vector model. The final step was to use a Bentley product called ModelBuilder to create and store the spatial 3-D database from our intelligent 3-D design. ModelBuilder is capable of creating a 3-D representation of a CAD feature and storing it in a spatial database as 3-D point and line geometry.

In the SHRP 2 project, each feature carries along with it the model intelligence (a collection of properties or feature attributes) to define an SDSFIE feature and enough information to allow the reconstruction of the 3-D CAD feature when the data are checked out by Bentley's CAD products for 3-D editing. Other vendors' CAD products can be configured to store their geometry in Oracle Spatial or any other database management system (DBMS) product with the proper spatial extensions

applied. IBM Informix, IBM DB2 Spatial Extender, and PostgreSQL/SDE are all products that have capabilities to support this environment. Files that provide the means to create the modified SDSFIE model that the project was built on are available at <http://www.trb.org/Main/Blurbs/171927.aspx>. DOTs wishing to use this technology with other CAD vendors' software should verify that the software can store 3-D CAD data in a spatial DBMS. In addition, the CAD vendors' design software must be capable of augmenting the 3-D model with the needed rendering constructs and other information required to reconstruct the 3-D CAD utility feature once it is checked out for editing from the DBMS with spatial extensions.

When all the site data were loaded, they were verified with the Internet Explorer Web Mapping tool. The screenshot in Figure 5.5 shows the software building the 3-D features and storing them in the 3-D spatial relational DBMS system (Oracle Spatial).

Figure 5.6 represents a 3-D design-ready civil model extracted from the spatial database. This model functions with all the standard Bentley Power InRoads civil design tools. Also used for this project is Bentley's Geo Web Publisher, which is driven by Bentley Map, and has been used to verify that the 3-D Utility Data Model can be leveraged using an available commercial database-neutral publishing application.

Figure 5.7 presents a web mapping view of this same model from the previous image. The model can be viewed, queried, or edited within either environment.

With the entire project intersection now residing in the 3-D storage environment, a typical workflow is demonstrated in Figures 5.8 and 5.9, showing changes to the gas utility system.

The example workflow is the extension of gas service to a local restaurant that occurred during the DOT construction

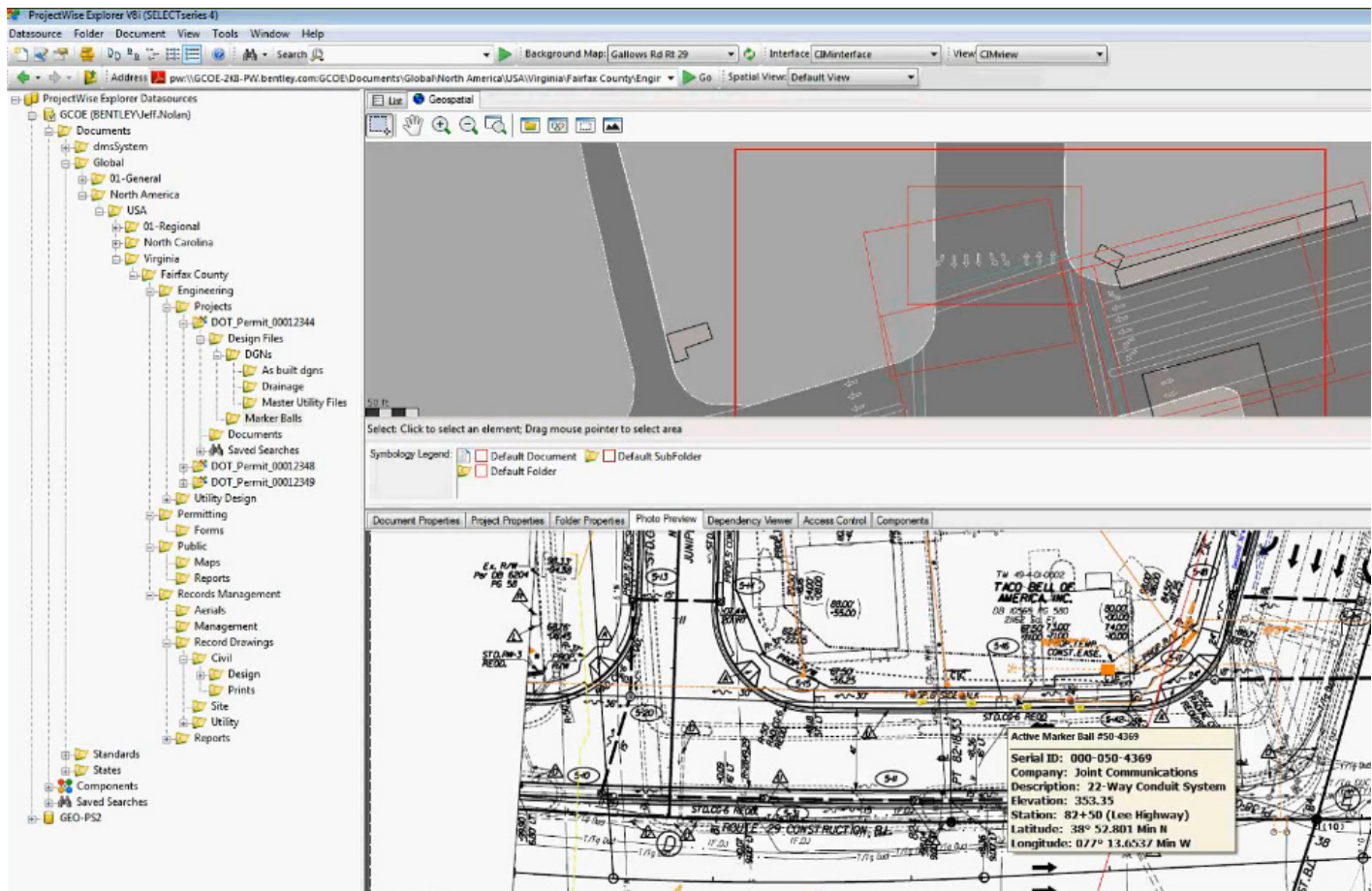

Figure 5.4. Folder hierarchy and 3-D model screenshot.

phase of the project. This utility work was part of the Gallows Road–Route 29 VDOT project. In Figure 5.8, the area highlighted in white shows the existing gas service and its length. Bentley ModelBuilder was used to create a new design model in the area of interest. The Bentley Power InRoads 3-D modeling tool was then used to add the extension to the gas service. Figure 5.9 shows the service extension in both 2-D and 3-D. Note the joint on the 3-D rendering showing the start of the gas service extension. Bentley ModelBuilder was used again to upload the 3-D design changes back into the 3-D Utility Data Model.

Throughout the life cycle of the project, the project information and tracking capabilities of the content management solution proved valuable for controlling information input into the 3-D model. Figure 5.10 shows the various project documents that were converted to build the initial 3-D utility model and the information that can be tracked for status and conversion process control.

Figure 5.11 depicts permits at various project locations. Note the different fill patterns showing the status of the permit. The representation of these permits overlaid on the utility infrastructure clearly defines areas where change has or will

take place and provides a powerful tool for understanding and managing updates to the 3-D infrastructure. All 2-D representations defining permits, DOT project extents, and other project administrative constructs are stored in the same spatial storage system (DBMS) as the 3-D utility data. A single connection to this unified environment yields data for both future design and the change management processes required to maintain an accurate 3-D utility model.

Updates from Third-Party As-Built Drawings

The next example demonstrates the inclusion of data supplied by a third party into the existing 3-D utility model of the Gallows Road–Route 29 project area. The example assumes that a new DWG civil design for a telecom line was submitted to a DOT operations group, responsible for utility model maintenance of a DOT project area. The example also assumes that the DOT project was completed and the 3-D model represented the final as-built condition. As a result, the content management solution sends an automated e-mail, instructing the DOT designer in the operations group to

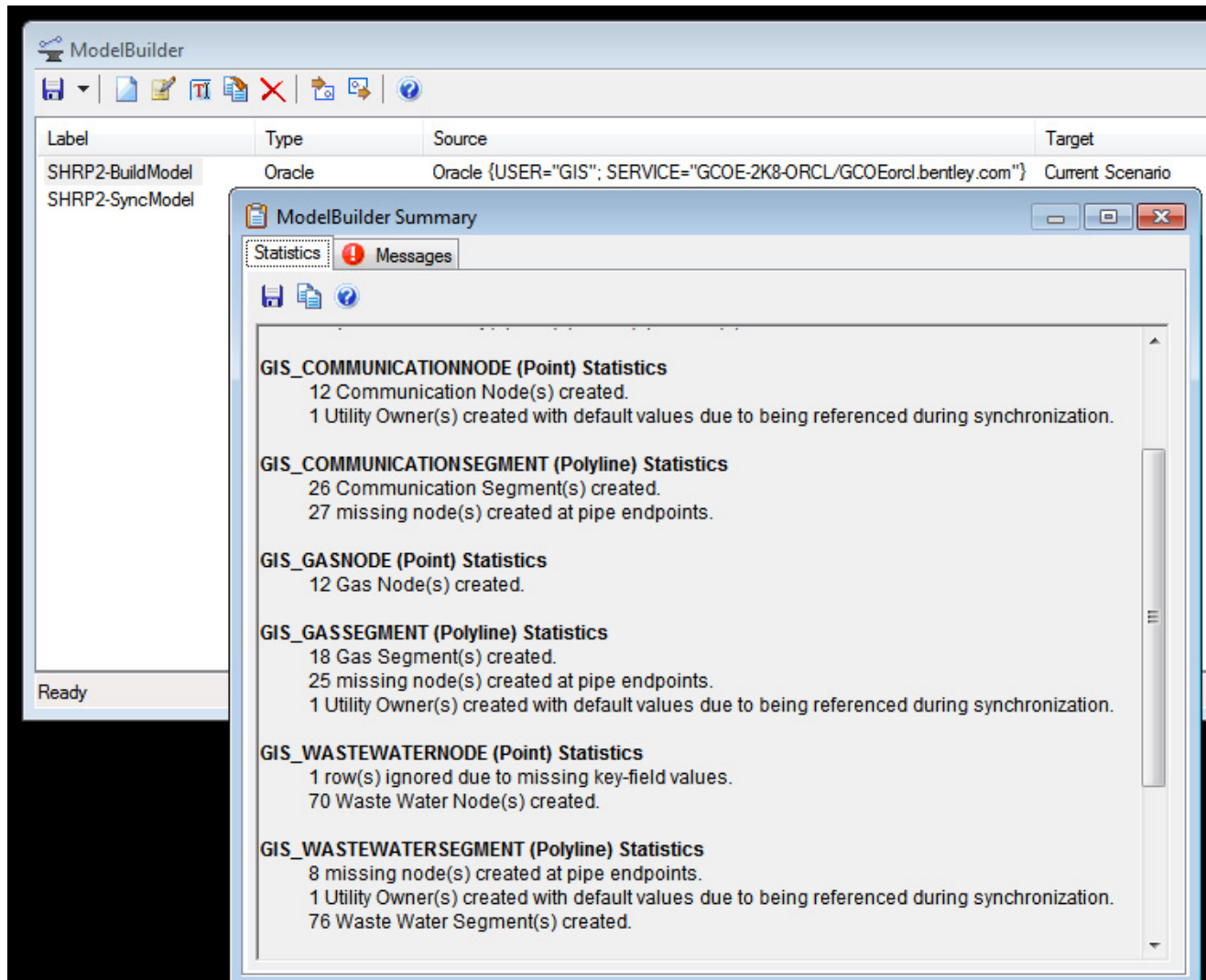

Figure 5.5. 3-D features and storage.

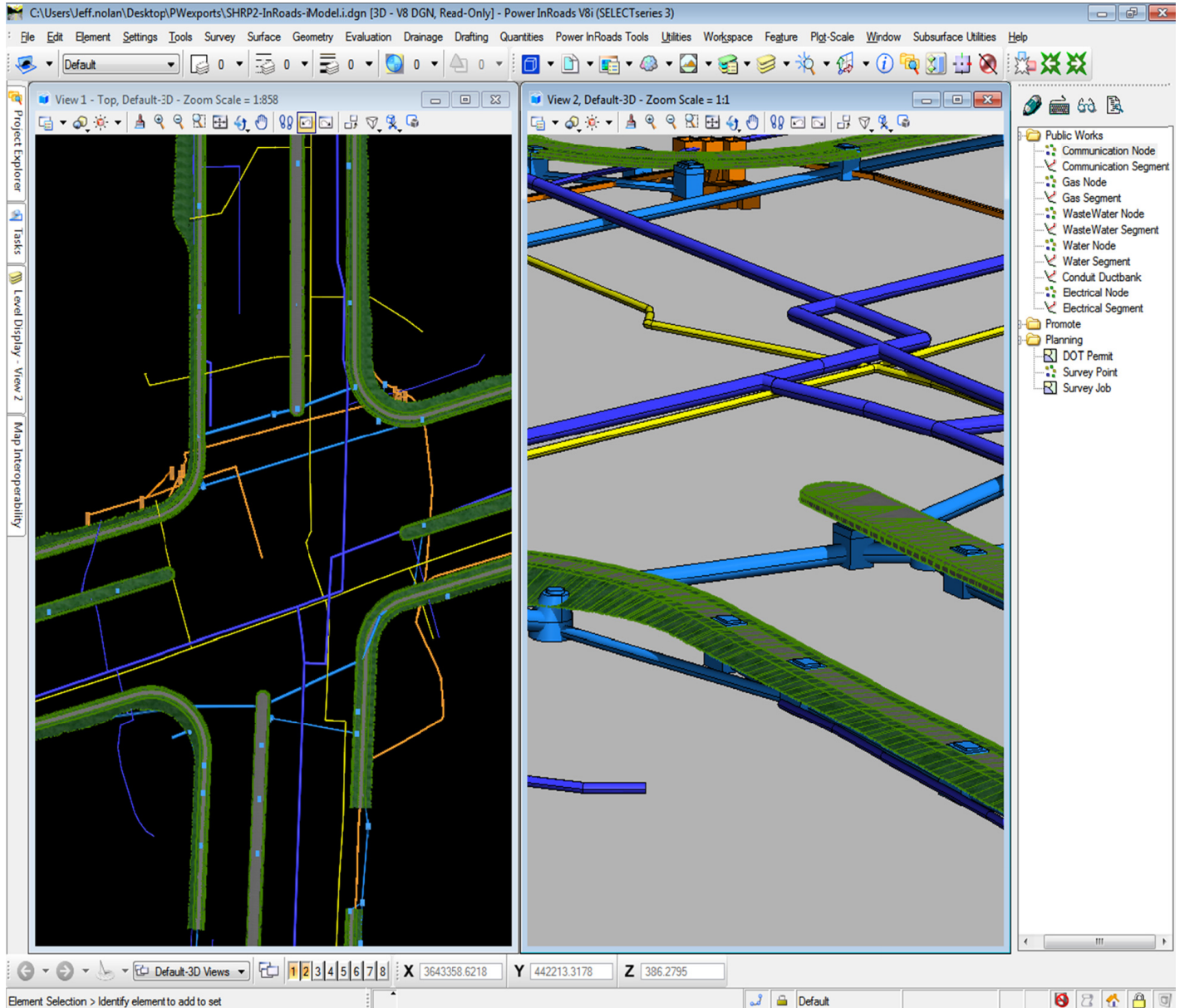

Figure 5.6. 3-D civil model (Bentley OpenRoads).

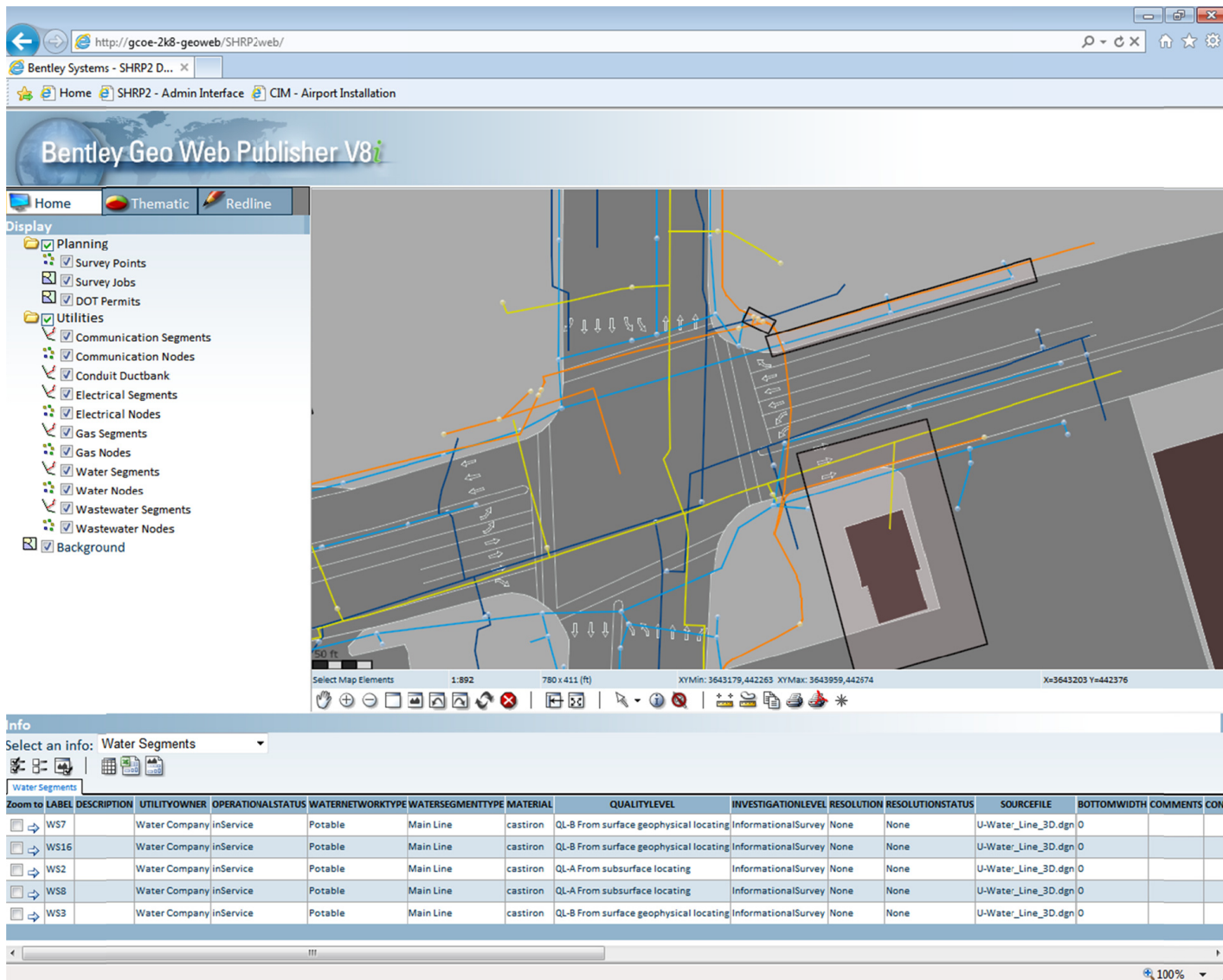

Figure 5.7. Web mapping view.

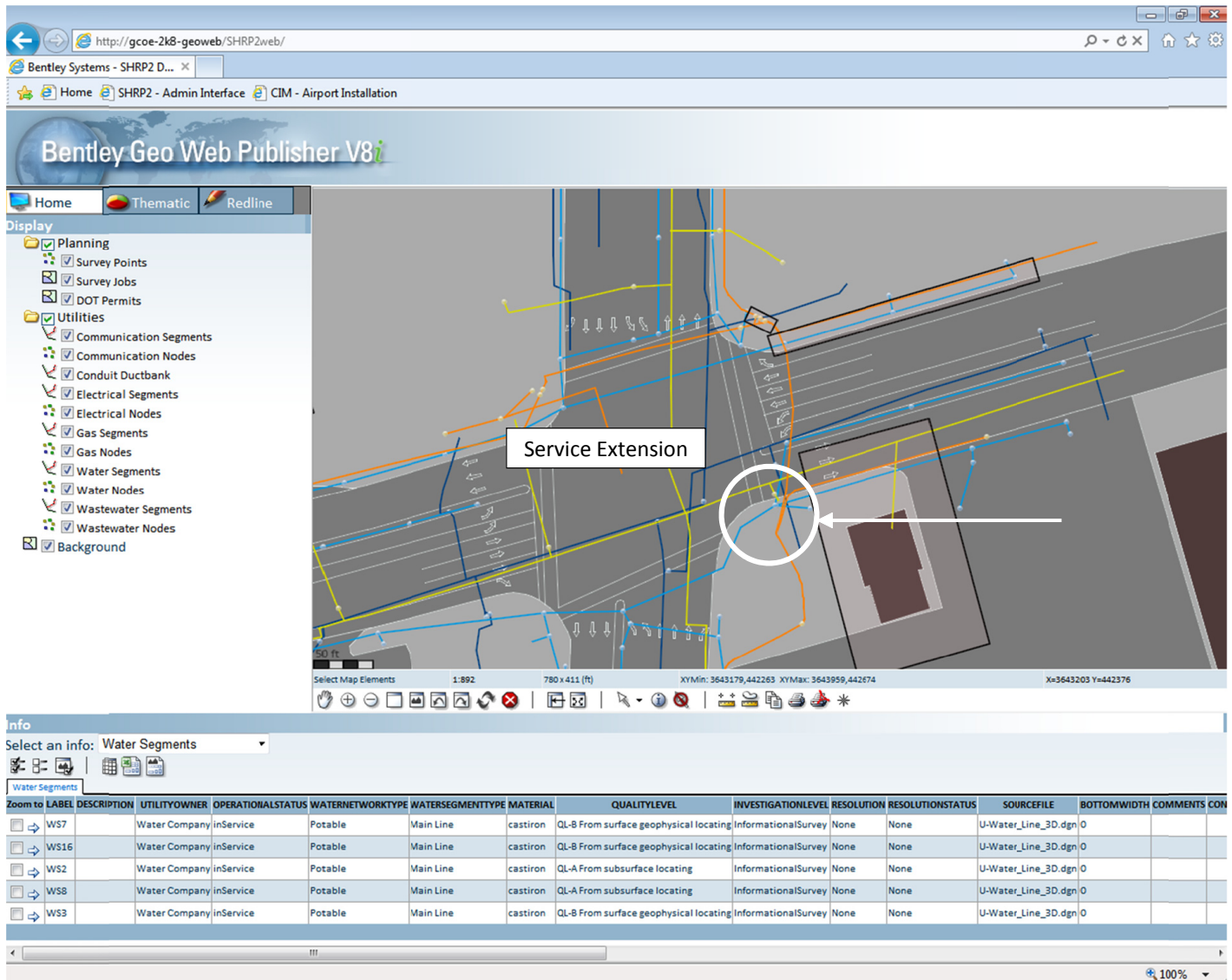

Figure 5.8. Modifying elements of the model: A.

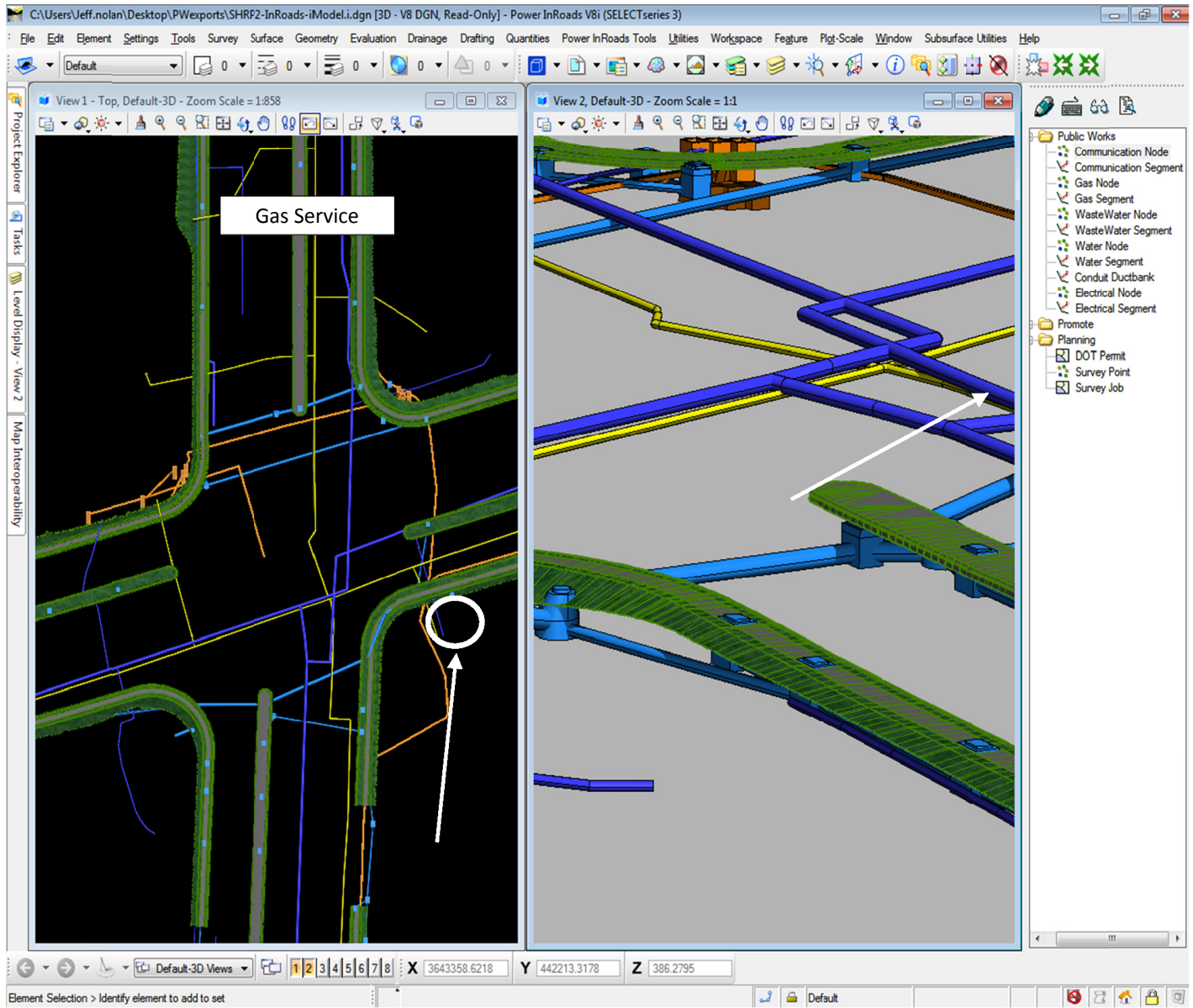

Figure 5.9. Modifying elements of the model: B.

The screenshot displays the ProjectWise Explorer V8i (SELECTseries 4) interface. The left pane shows a hierarchical tree view of the project structure, including folders for 'Engineering', 'Design Files', 'DGNs', 'Documents', and 'Utility Design'. The right pane shows a list of documents with columns for Name, Description, File Size, State, Out to, and Updated. Below the list, the 'Properties' tab is active, showing details for a 'Transportation Project'.

Name	Description	File Size	State	Out to	Updated
11395pg3.pdf	11395pg3	1,247 KB			07/28/13 8:07:21 PM
11395pg4.pdf	11395pg4	1,708 KB			07/28/13 8:07:22 PM
11395pg5-all AMB 052010.pdf	11395pg5-all AMB 052010 (ALL)	1,293 KB			07/28/13 8:07:23 PM
11395pg5.pdf	11395pg5	1,177 KB			07/28/13 8:07:22 PM
11395pg6-MASTER.pdf	11395pg6-MASTER (ALL)	892 KB			07/28/13 8:07:10 PM
11395pg6.pdf	11395pg6	1,403 KB			07/28/13 8:09:03 PM
11395pg7.pdf	11395pg7	1,282 KB			07/28/13 8:07:11 PM
11395pg9-MASTER.pdf	11395pg9-MASTER	930 KB			07/28/13 8:07:11 PM

Properties (Project Type - Transportation Project)	
Project Number	00012344
Project Name	Gallows Rd 29 Main Project
Project Type	Intersection Improvements
Project Manager	Jeff Nolan
Project Budget	1500000
Project Cost	\$1420000
Inspected	Yes
Notes	
Project Status	Complete
Percent Complete	100
Project Requested	12/17/12
Project Started	02/12/13
Project Completed	06/19/13
Contractor Company	General Contractor
Contractor e-mail	contact@gc.com
Contractor Name	Helen G
Contractor Phone	555-234-3453

Figure 5.10. Illustration of document storage.

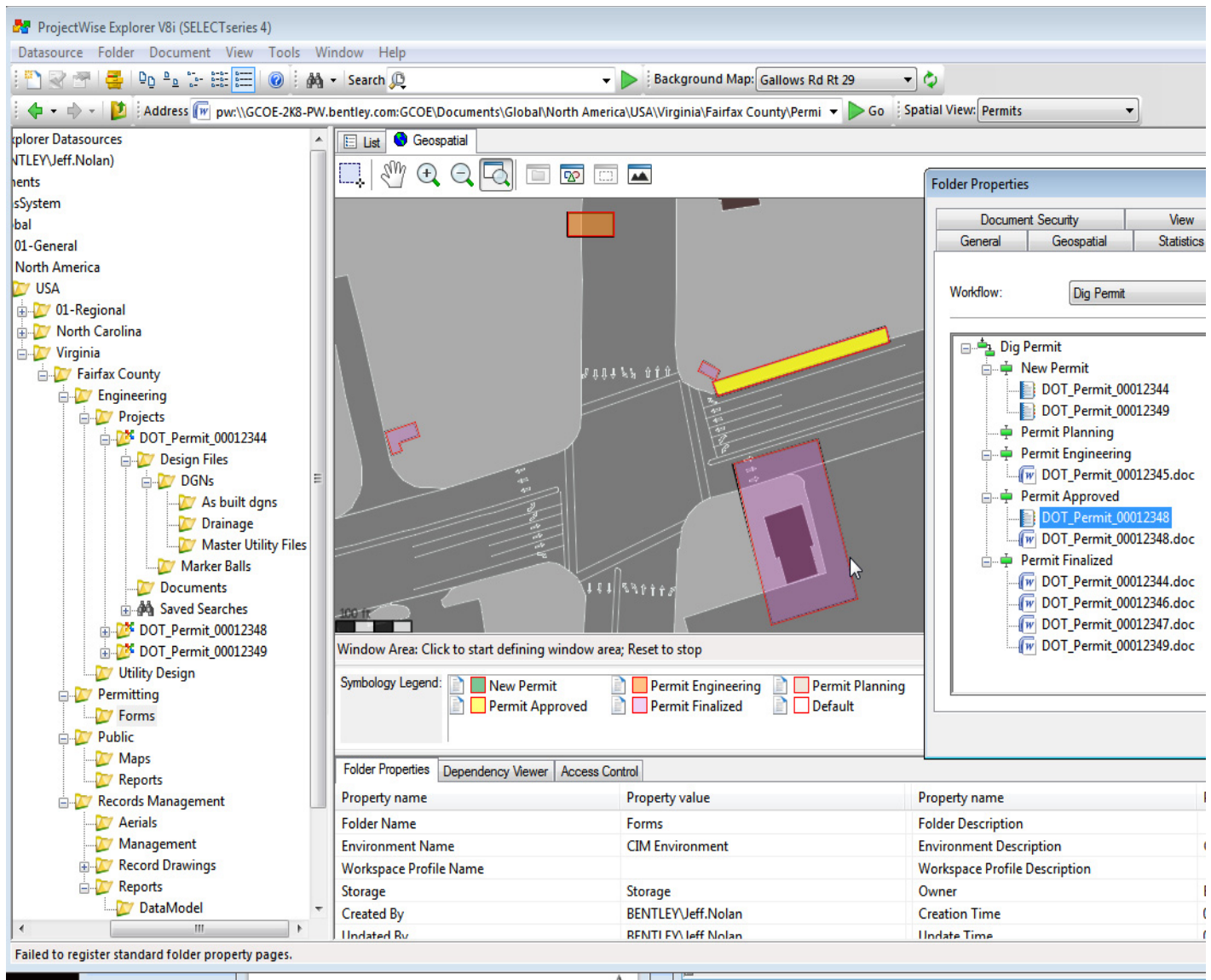

Figure 5.11. Illustration of permits.

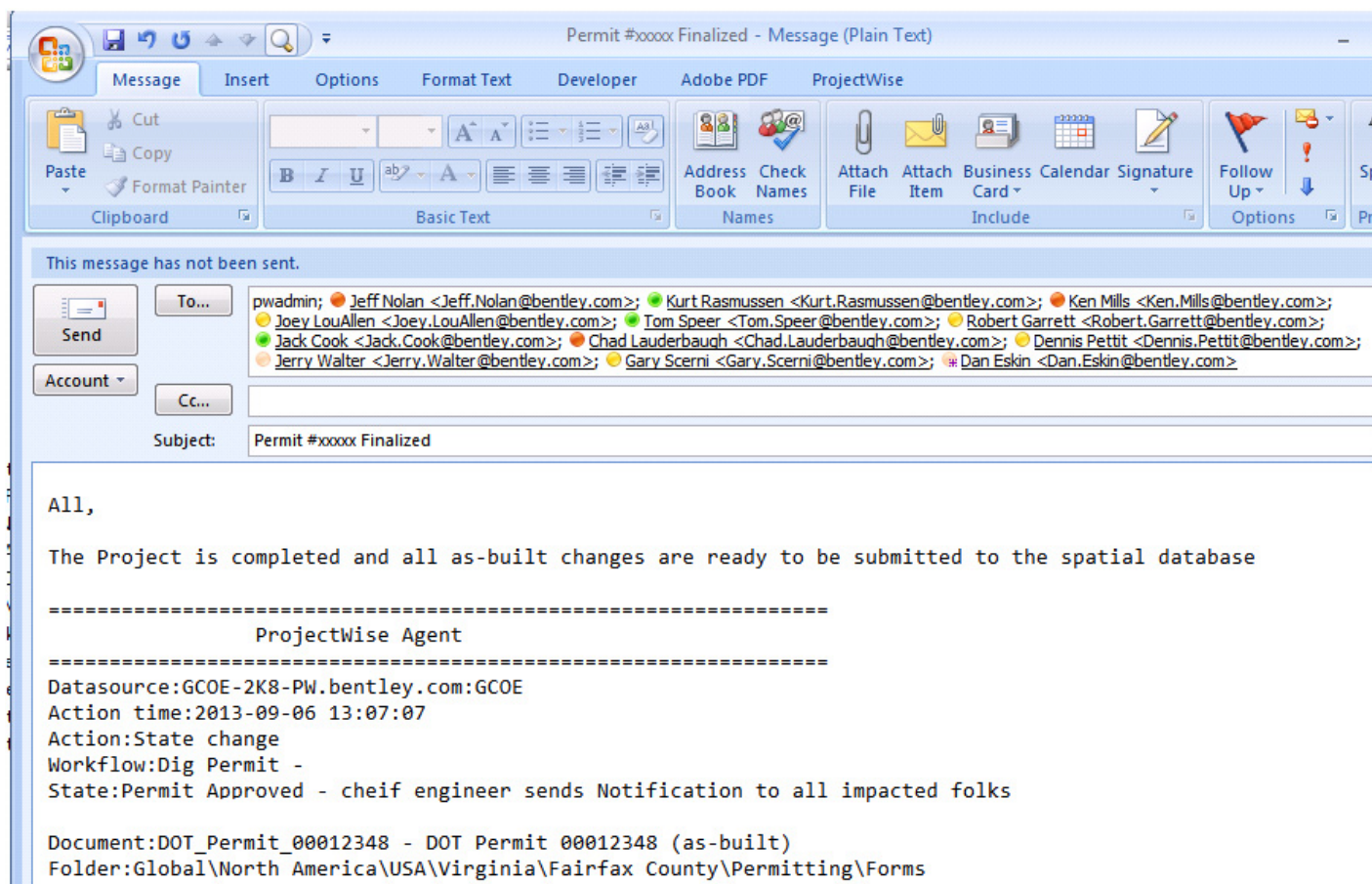

Figure 5.12. Third-party data Step 1.

review the new telecom line and then post the changes into the master 3-D Utility Data Model (see Figure 5.12).

The designer uses Bentley Power InRoads to bring the DWG design file into the master 3-D design session (see Figure 5.13).

The designer then incorporates the new civil design changes into the master 3-D Utility Data Model, posts those changes to the master 3-D Utility Data Model, and finalizes the state of the permit so that all interested parties know it is complete (see Figures 5.14 and 5.15).

The permit colors change (see Figure 5.16) to show the update to the model was completed from within the content management solution, providing a clear point of project review for management (see Figure 5.17).

Using the 3-D Utility Data Model for Interactive Design

As part of the research, the addition of new utility objects into the 3-D Utility Data Model using conflict detection and advanced 3-D editing functions was also developed and demonstrated. The demonstrations once again used Bentley Power

InRoads and ModelBuilder to show the various steps performed. The workflow was built from a new permit, adding a new gas main into an existing building.

In Step 1, the new gas line is sited according to the permit requirements (see Figure 5.18).

In Step 2, the 3-D civil intelligence is added to the gas line (see Figure 5.19).

Step 3 verifies whether the new gas line meets clearance requirements (see Figure 5.20).

In Step 4, the new gas line is adjusted by editing the profile view dynamically (see Figure 5.21).

Step 5 verifies that the 3-D Utility Data Model compliant attributes are properly filled in (see Figure 5.22). These are mandatory attributes or properties that, at a minimum, are required to fully define an intelligent feature. Compliance is specified so that the features can consistently provide information about themselves. A property or attribute is often defined as mandatory or compliant so that a function can run against a collection of elements without fear that the system cannot be processed because a single linking property is missing. Good examples are a switch or a fuse, or a gas or water

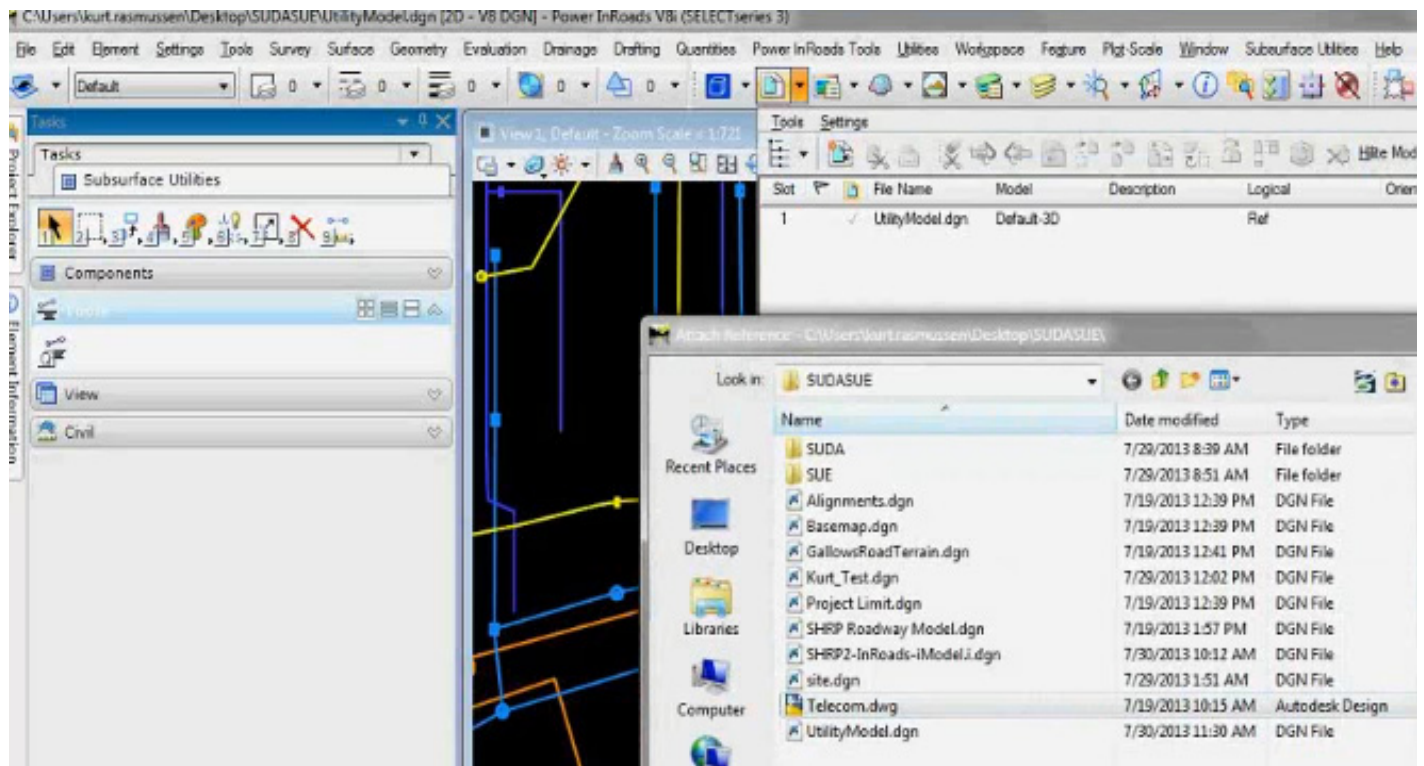

Figure 5.13. Third-party data Step 2.

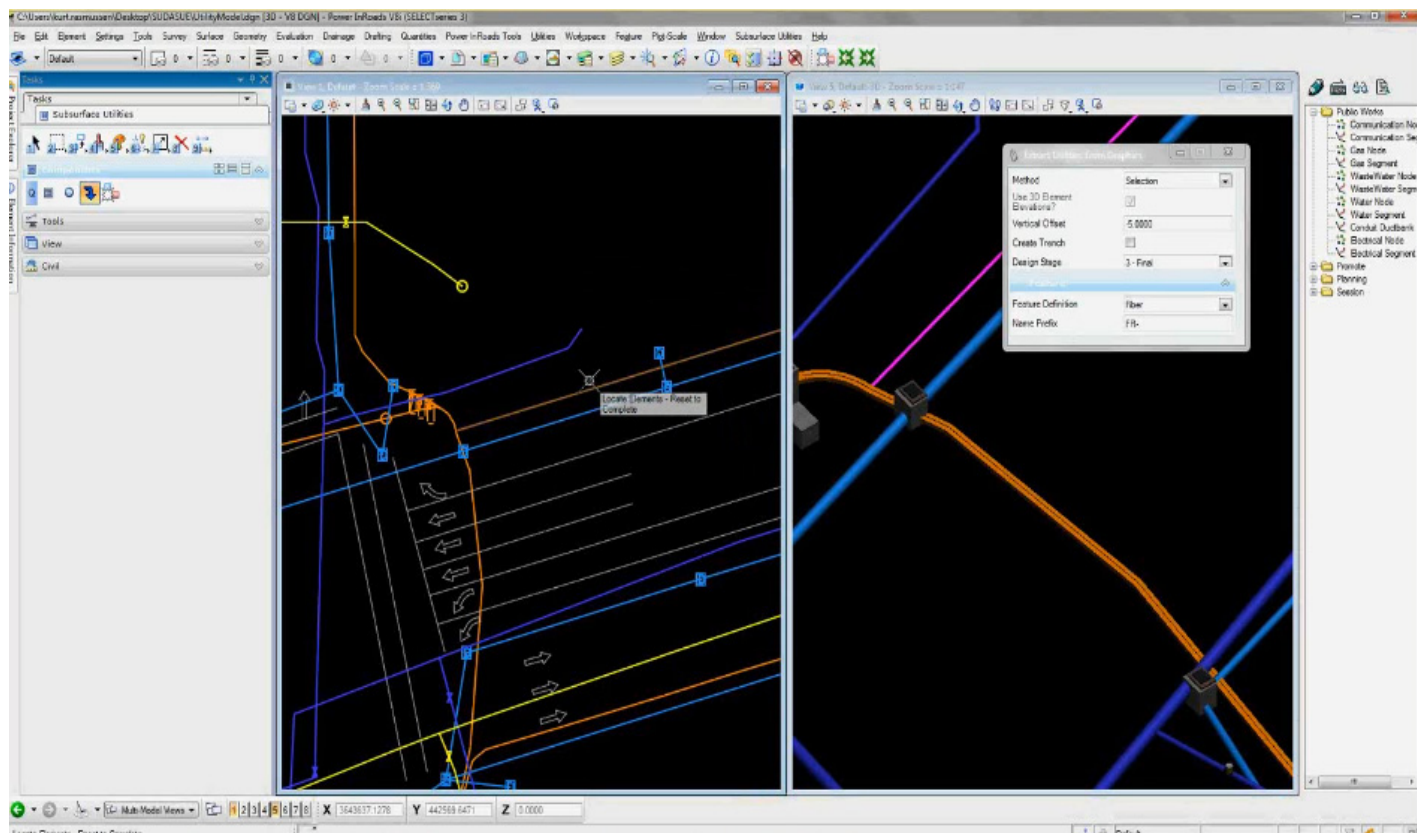

Figure 5.14. Third-party data Step 3.

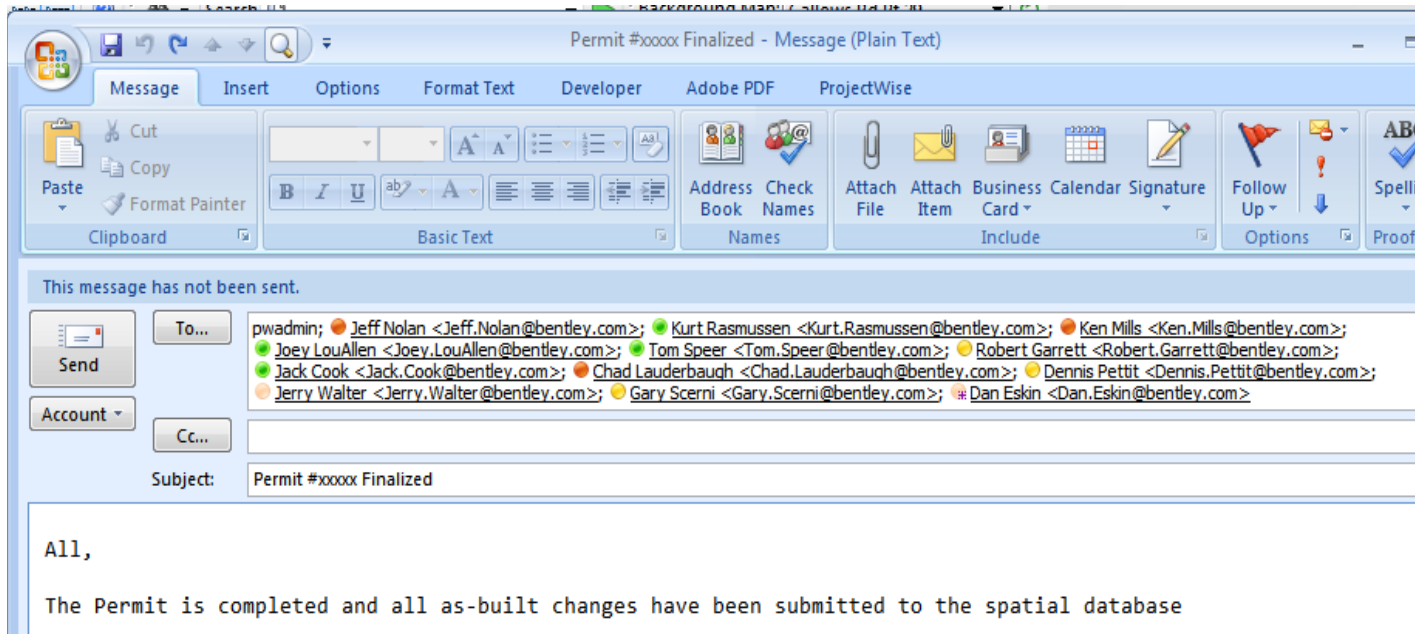

Figure 5.15. Third-party data Step 4.

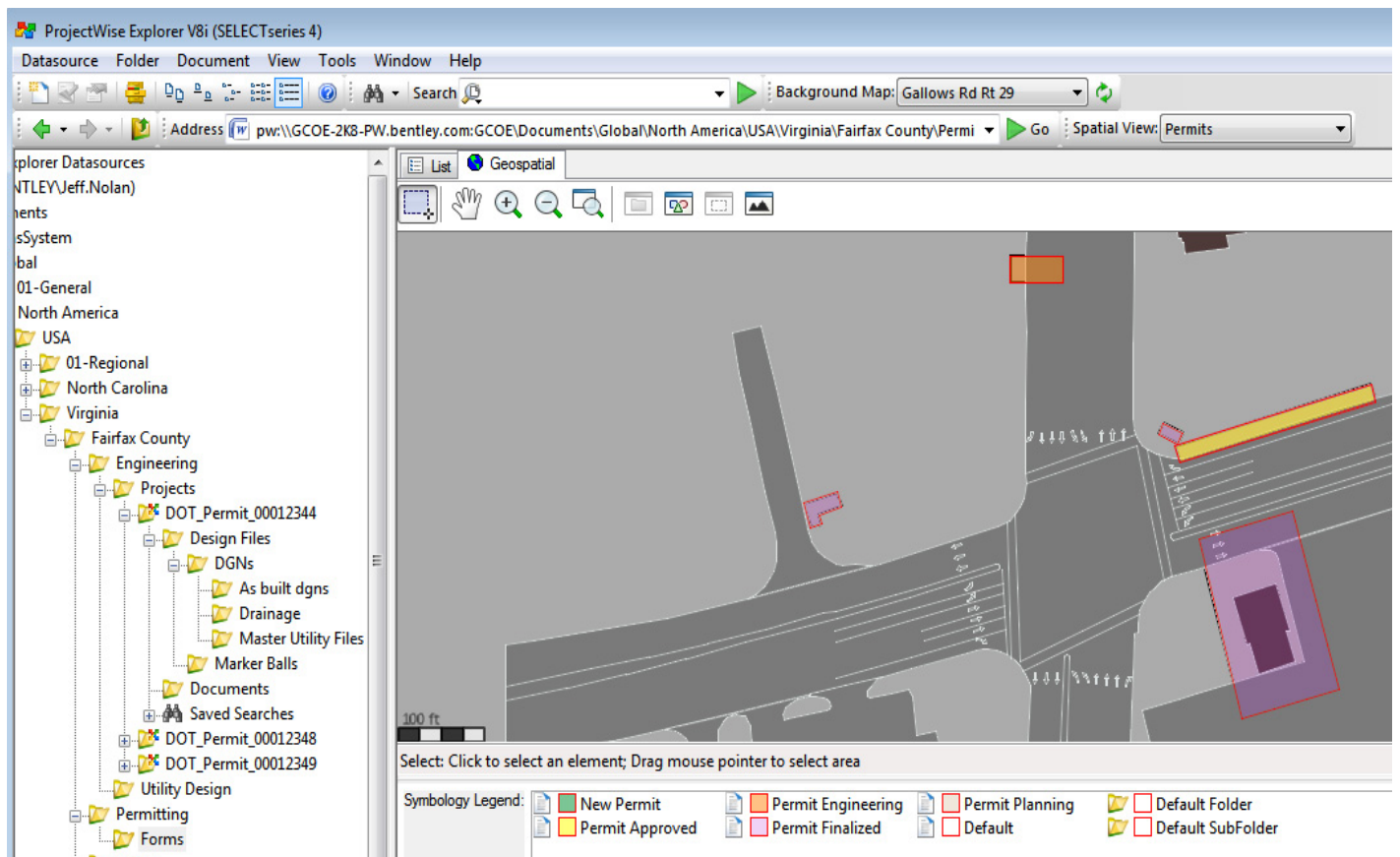

Figure 5.16. Third-party data Step 5.

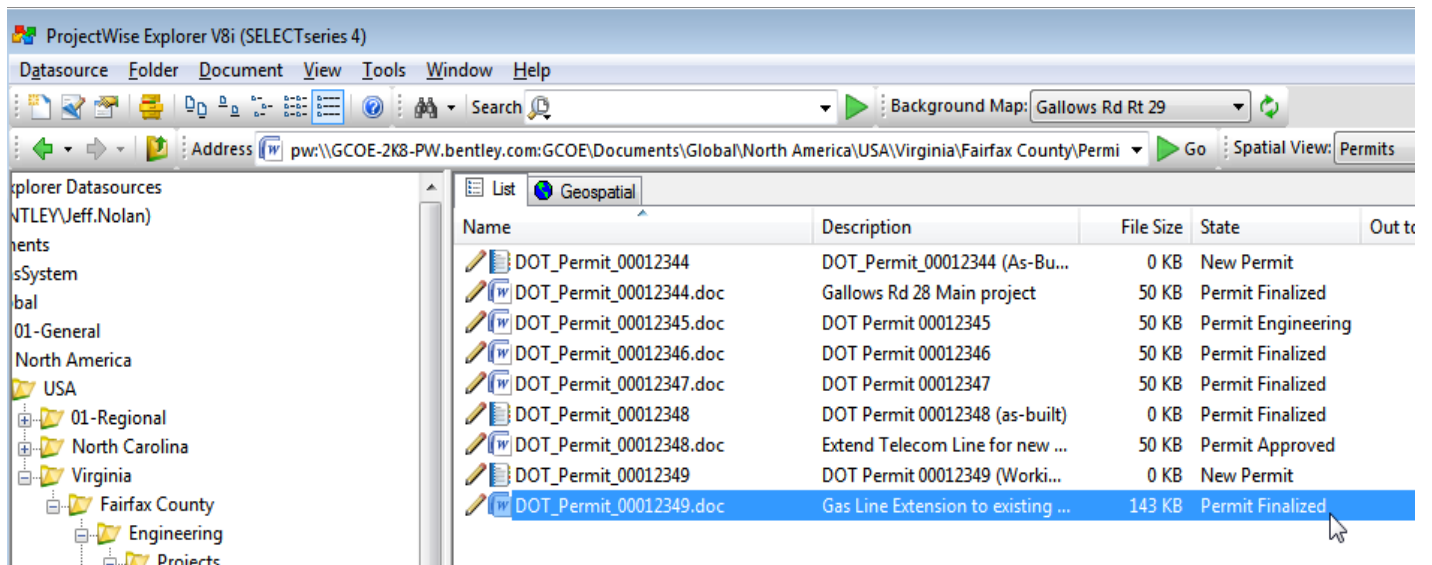

Figure 5.17. Third-party data Step 6.

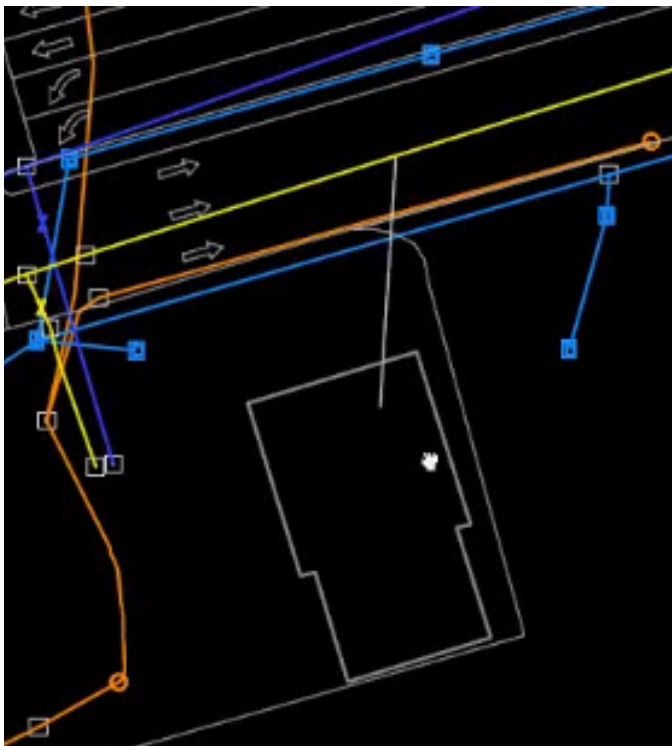

Figure 5.18. Interactive design Step 1.

valve. Each has an operational property that is mandatory and that is its state. The fuse, valve, or switch must have a state. The state must be open or closed. The switch state cannot be null; a software trace will fail at each device that is null (not defined). These intelligent components must be opened or closed if their behavior is binary. Some valves may throttle, so their state can be open, closed, or some percentage of open—but never null.

Use the Bentley Power InRoads ModelBuilder to upload the changes from the design file to the 3-D Utility Data Model, and save the design file back into the content management repository for later retrieval (see Figure 5.23).

Finally, in Step 7, the changes are reviewed through the content management web viewer to verify that the graphics and the data that were written with the Bentley Power InRoads design application into the 3-D Utility Data Model have gone through (see Figure 5.24).

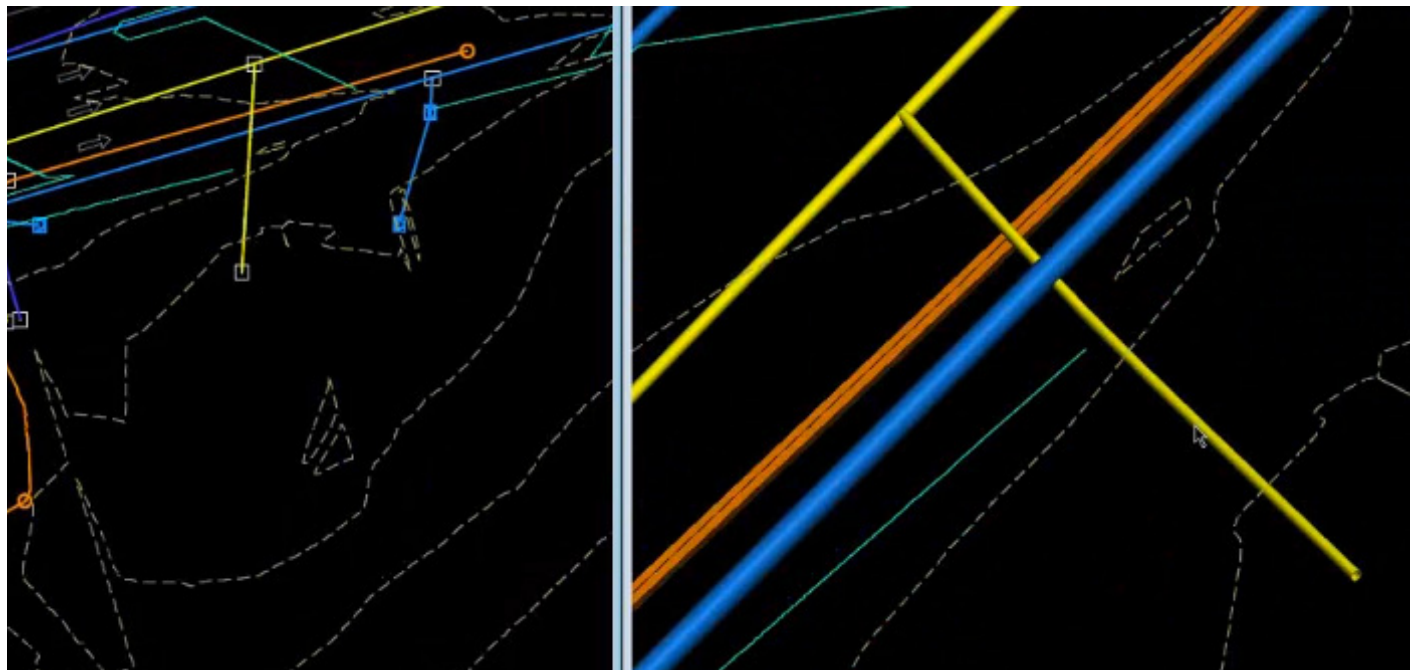

Figure 5.19. Interactive design Step 2.

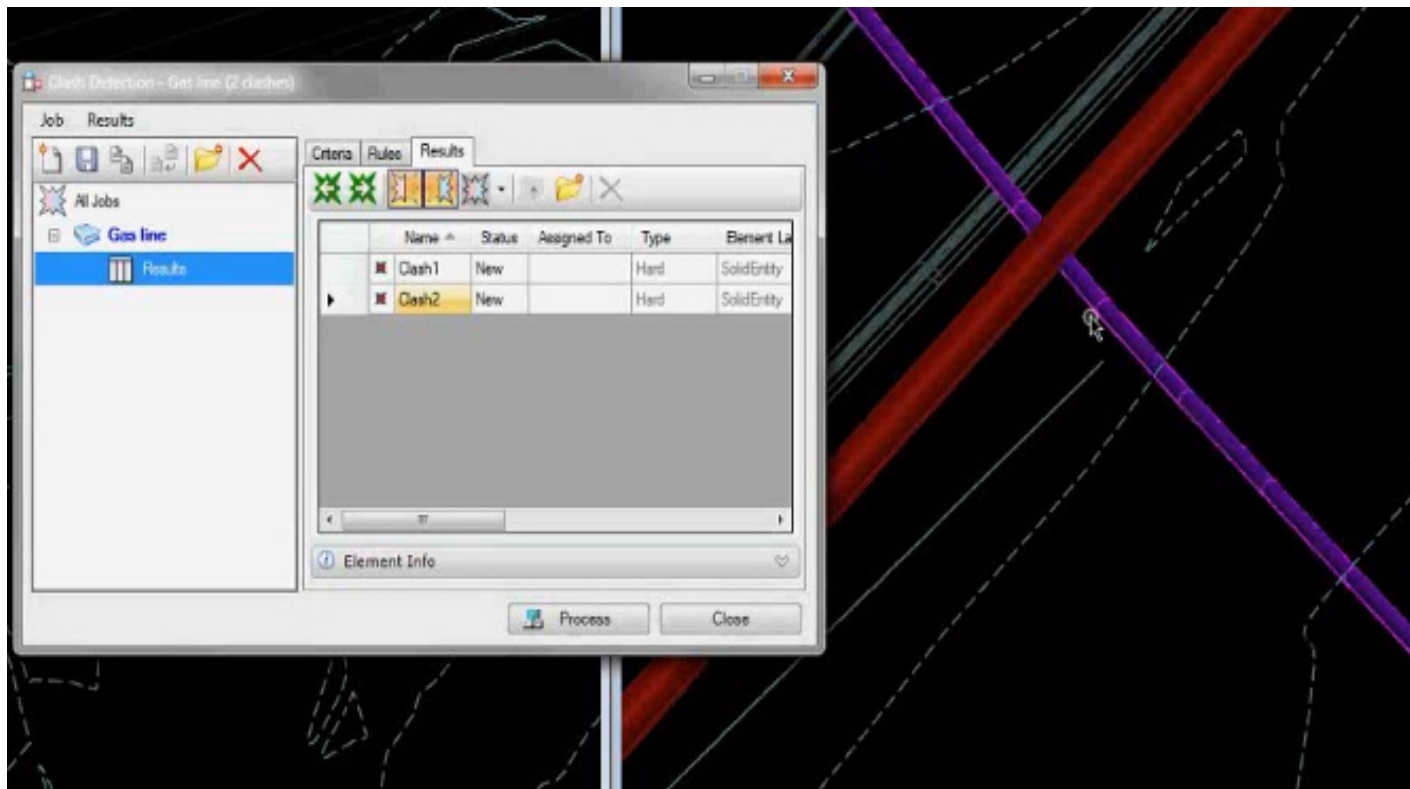

Figure 5.20. Interactive design Step 3.

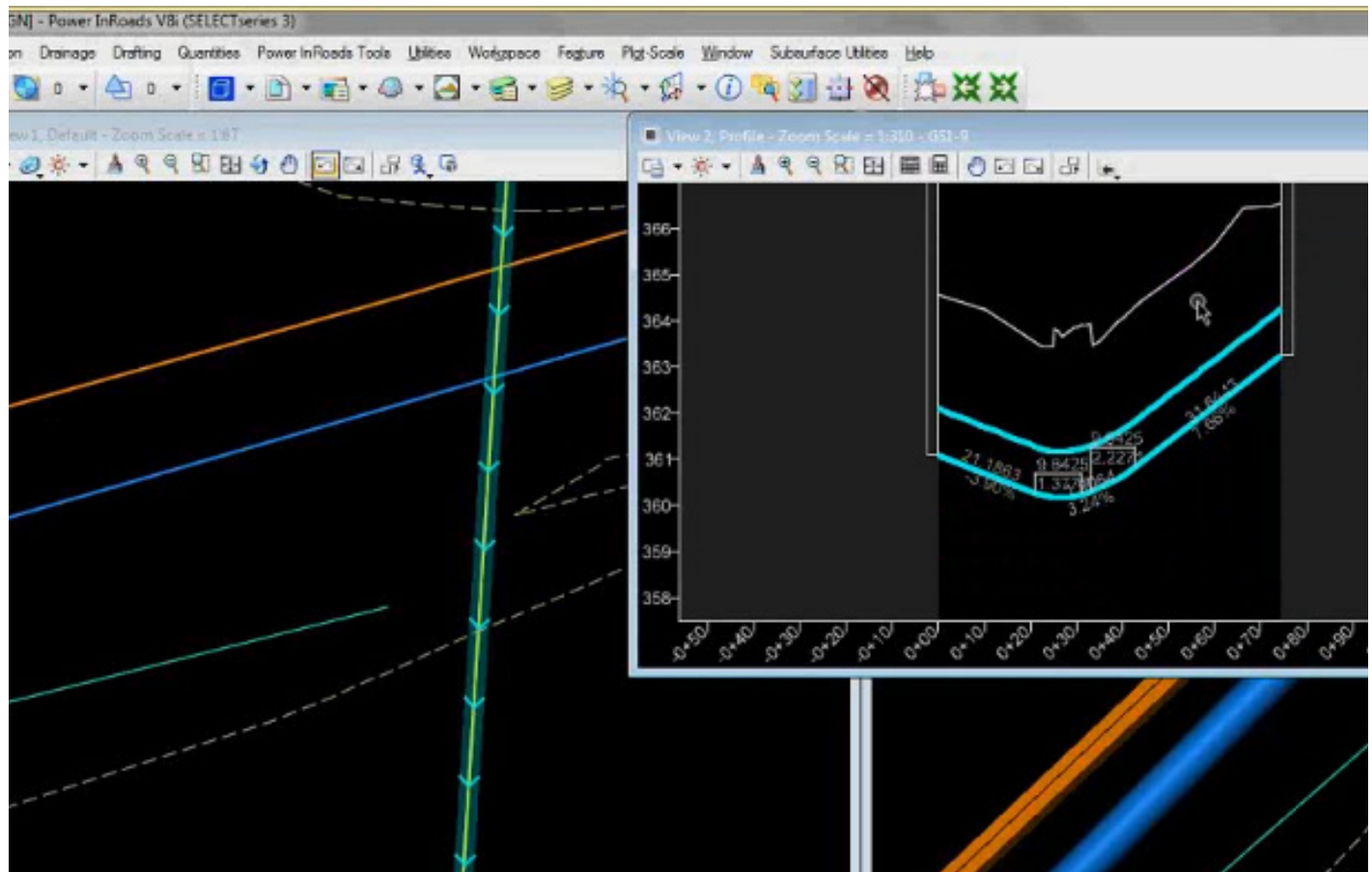

Figure 5.21. Interactive design Step 4.

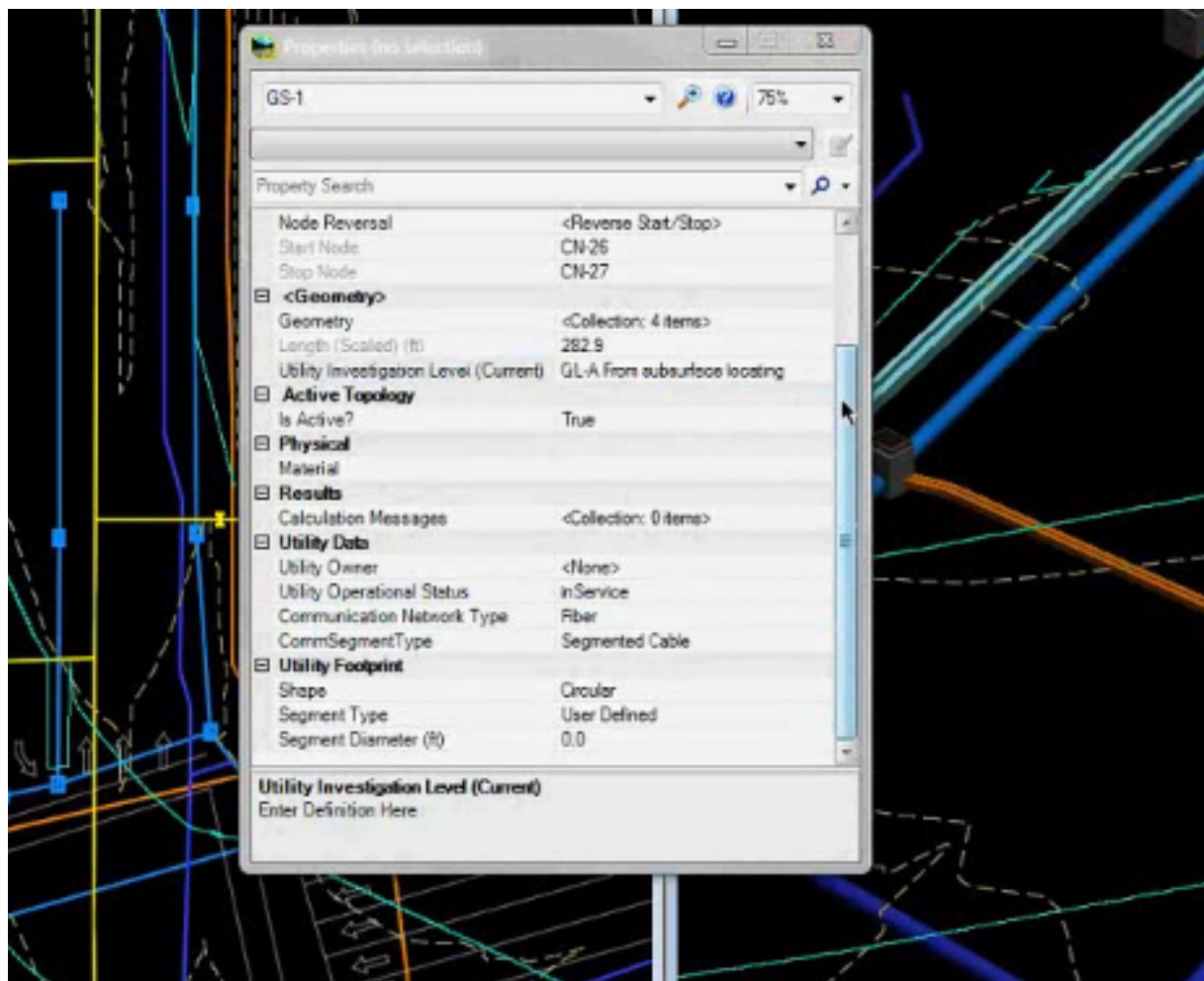

Figure 5.22. Interactive design Step 5.

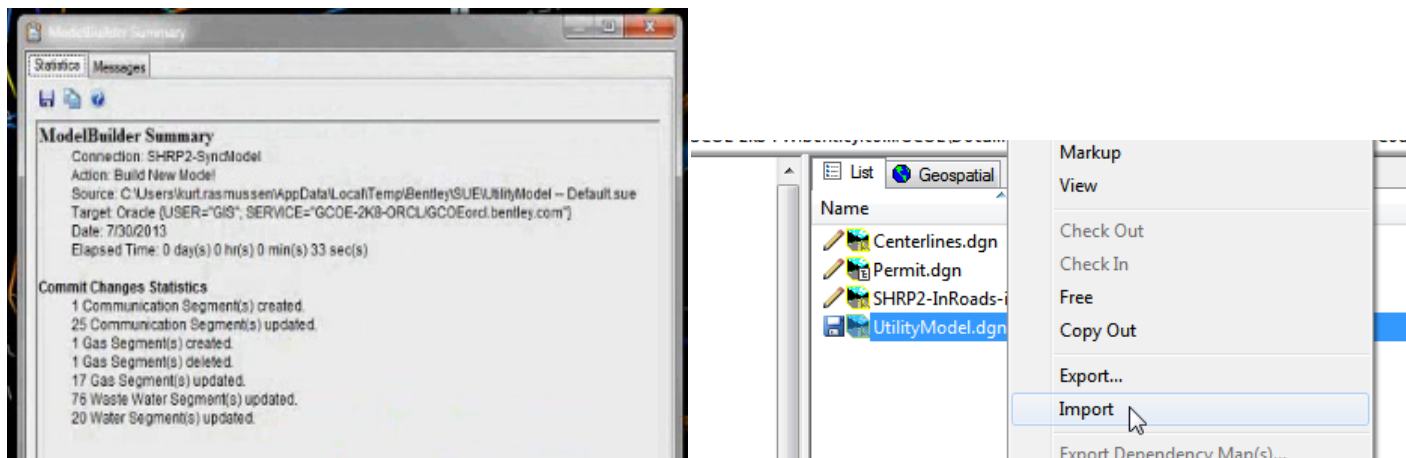

Figure 5.23. Interactive design Step 6.

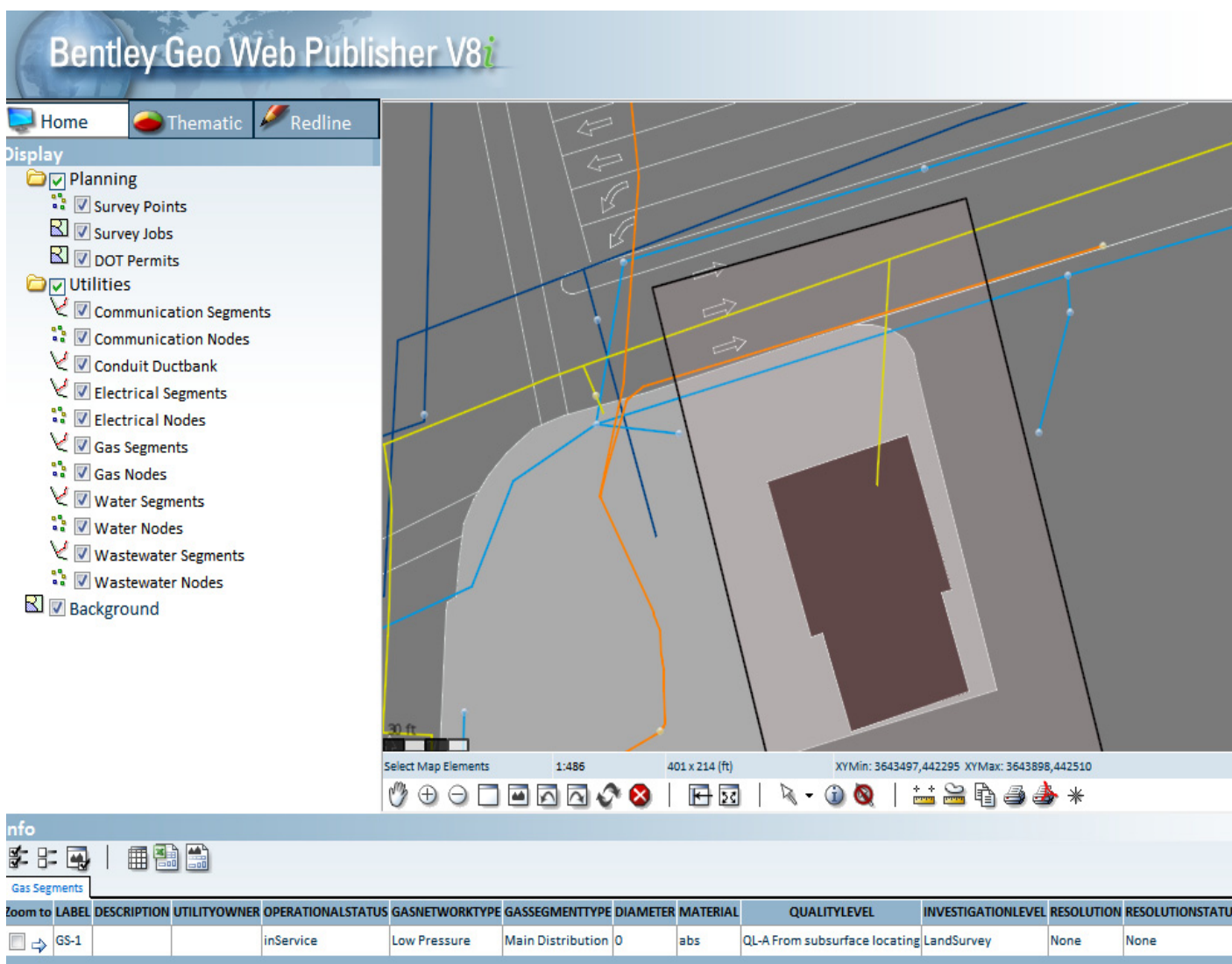

Figure 5.24. Interactive design Step 7.

CHAPTER 6

Conclusions and Recommendations

Recommendations

1. *Management of the 3-D utility solution should occur at the state level.* It is recommended that the system described in this report be managed at a state level. State DOTs have the greatest opportunity to ensure effective implementation and make the program a success. Adopting, adapting, and using this 3-D model in more than one state can provide opportunities for data stored in the system to be exchanged transparently across multiple DOTs when projects span state boundaries.
2. *Traditional work processes will need to be reengineered to create and maintain a new 3-D utility system.* Many of the processes described in this document are not new to DOTs. However, having an organization that monitors the changes of a project area, receives data for updating the 3-D utility system, and manages access for other agencies is, in some respects, new. If the DOT becomes the agency responsible for operating and maintaining the 3-D utility system, the DOT would authorize access to the system, assign user accounts, and set up the proper roles for access to the data for the different types of users who would use this information. These steps will require more interaction with other organizations, and those interactions in all probability will require some level of reengineering. It also makes sense to consider changes to the permitting process that include requirements for the permittee to provide as-built data (x , y , z coordinates) using specific data compatible with the repository and to consider guidelines for how the data are transferred.
3. *Establish DOT boundaries defining the right-of-way for all highways managed by a state DOT.* It is recommended that all permit requests be compared geospatially with the public highway right-of-way. If a permit application is found to coincide with any part of the DOT right-of-way, then the permit should be registered in the 3-D utility storage system.
4. *The process by which as-built drawings are produced should be reconsidered.* It is recommended that transportation agencies consider changing the practice of as-built reporting processes that are developed by marking changes on design plans. It is recommended that as-built reporting be established by active measurement and sampling processes that document actual as-built utility locations. The practice of marking up design drawing exceptions (i.e., exception reporting) as a means for creating as-built drawings can easily overlook changes to a design. Exception reporting does not validate conformance to engineering design.
5. *The permit application process needs effective controls and procedures to ensure that proposed utility designs and as-built drawings are delivered to the 3-D storage system.* It is recommended that permit controls and automated data-sharing processes be instituted to ensure that utility relocation is understood during design, construction, and post-construction by the state DOTs. One-Call notices and their associated white line features should be integrated with the permit process in the 3-D storage system as a check and status reminder for document submittals.
6. *Systems that handle permit issuance outside of state DOT control should be built to share data with the state DOT systems.* For states in which the DOT does not have universal authority over all highway ROW utility installations, it is recommended that the different permitting organizations integrate their permit processes so that, at a minimum, copies of the permits issued by other entities share utility changes inside of the highway right-of-way with the DOT. The recommendation is made to provide a continuing record of utility installations for future use by all transportation organizations.
7. *Excavations within broad area permits need to be documented.* It is recommended that in states with DOTs that issue permits for broad geographic areas of allowed pavement opening, the permittee be required to record and (electronically) submit to the DOT changes at each

excavation location. These changes should include the surface boundary polygon, the reason for the excavation, and the utilities affected. The excavation boundary should be accompanied by drawings showing both the proposed utility design and the final as-built conditions.

8. *Additional research and development should be undertaken to improve the collection of as-built utility features for the 3-D storage system.* Utility companies across the country all have different motivations for expending resources to improve records defining their delivery systems for both underground and aboveground installations. The work that is performed to collect this information is often based on documenting changes from the design drawings (exception reporting) rather than on an actual as-built survey. Improved systems that eliminate exception reporting to create an accurate record of the actual as-built utility are recommended. More research and development work is recommended to understand the barriers to improving utility location information and to improve and create more cost-effective methods of capturing ASCE 38 quality level A, as-built information. The research should focus on both field data collection and back-office processing of as-built information, with cost as a key business driver.
9. *The use of RFID markers should be considered for all new utility installations in the DOT right-of-way.* It is recommended that all operators that install new utilities or expose existing utilities use RFID markers to preserve the location of those utilities without the need for reexcavation. The choice of the specific types of RFID markers should be left to the DOT and utilities, but the requirements to install should be specified at the issuance of the permit. It is also recommended that the DOT map each RFID marker to maintain a record of its existence and provide a simple means of locating the utility system in the DOT right-of-way in the future. It is recommended that the DOT do this work and map the markers in the 3-D storage system.
10. *Systems for accessing 3-D utility storage system information must be integrated into both the permitting operations and utility planning and engineering departments.* The 3-D utility storage system should be accessible to the permitting organizations and to engineering and construction organizations to support all future work in the DOT ROW. The DOT will need to define the process and parameters for data sharing. Additional software applications should be developed to easily define permit boundaries and excavation areas in the case of a generalized permit. Access to the data in the 3-D utility storage system by engineering and construction organizations will enable the use of this information in the development of new designs and the development of a detailed understanding of the utility systems for construction

planning operations. The system will have little value if it is not integrated in the workflow of these organizations.

Conclusions

The proof-of-concept demonstration project showed that the 3-D Utility Data Model and repository can be used with available technologies (e.g., Bentley, in the case of the pilot) to initially load, use, update, and store 3-D utility location information on highway right-of-way projects. Other software vendor products can be used in place of the Bentley products that were demonstrated—although not without some integration effort. Compatibility between software platforms can be an issue for 3-D data exchange, as several different standards are in use.

The success or failure of this research effort and recommendations is predicated on identifying and tracking change in both the field and the back-office systems. The technology recommended in this research is available or will be available to all DOTs in a variety of vendor products and system configurations. A potential impact that has not been discussed at length, but remains central to successful implementation, is acceptance of change. If the DOT builds a system as discussed in this report, will it be used? Several questions and concerns will need to be addressed, including the following:

- Will the parties responsible for new projects have confidence in the data that are in the new system, use the data without question, and not inventory the entire project area to understand the utility systems?
- Will the implementation of the system have enough controls to ensure that the representation of the utility systems can be taken at face value and the planning and design can proceed?
- Will the change processes recommended be implemented in a form that will build compliance with and confidence in the system?

Adopting the recommended technology and processes developed from this research will have inherent challenges unrelated to technology—they are cultural in nature. Therefore, it is also recommended that implementation of all these processes and solutions be followed with rigorous compliance processes to test the capability of the system to accurately reflect the record of actual utility networks installed in a given project boundary. The compliance processes should include feeder systems that track change, such as the permitting operations and data collecting processes implemented externally by the utilities and internally by the DOT. Complex systems designed to control complex processes are never implemented with perfection. With proper monitoring and reengineering, the described system can be successfully implemented to fulfill the original objectives of SHRP 2 Project R01A.

References

- GITA, ROADIC Task Force. 2003. *Study Mission to the Road Administration Information Center (ROADIC)*. Geospatial Information & Technology Association, Tokyo, Japan.
- Müller, H., and E. Curtis. No date. Extending 2D Interoperability Frameworks to 3D. *The International Archives of the Photogrammetry, Remote Sensing and Spatial Information Sciences*, Vol. 34. <http://www.snowflakesoftware.com/wp-content/uploads/2012/03/3DFrameworkPaper.pdf>.
- Nagel, C., A. Stadler, and T. Kolbe. 2009. Conceptual Requirements for the Automatic Reconstruction of Building Information Models from Uninterpreted 3D Models. *The International Archives of the Photogrammetry, Remote Sensing and Spatial Information Sciences*, Vol. XXXVIII-3-4/C3. Institute for Geodesy and Geoinformation Science, Technische Universität, Berlin, Germany. http://www.isprs.org/proceedings/XXXVIII/3_4-C3/GeoWeb2009_AcademicTrack_Proceedings.pdf.
- Scianna, A., A. Ammoscato, and R. Corsale. 2006. A Step Toward Interoperability: Managing 3D Urban Data with GML Structure. Urban Data Management Symposium, Aalborg, Denmark, pp. 9.119–9.125. http://www.academia.edu/4385626/A_STEP_TOWARD_INTEROPERABILITY_MANAGING_3D_URBAN_DATA_WITH_GML_STRUCTURE.
- Stadler, A., C. Nagel, G. König, and T.H. Kolbe. 2008. Making Interoperability Persistent: A 3D Geo Database Based on CityGML. Presented at 3rd International Workshop on 3D Geo-Information, Seoul, South Korea.
- TRB. 2009. SHRP 2 R01A Technologies to Support Storage, Retrieval, and Utilization of 3-D Utility Location Data. Transportation Research Board of the National Academies, Washington, D.C. <http://apps.trb.org/cmsfeed/TRBNetProjectDisplay.asp?ProjectID=2673>. Accessed Oct. 7, 2013.

APPENDIX A

Data Schema

Tables by Category

Public Works Features

COMMUNICATIONNODE
COMMUNICATIONSEGMENT
CONFLICTNODE
ELECCONDUITBANKSEGMENT
ELECTRICALNODE
ELECTRICALSEGMENT
GASNODE
GASEGMENT
POLNODE
POLSEGMENT
THERMALNODE
THERMALSEGMENT
UTILITYFEATURE
WASTEWATERNODE
WASTEWATERSEGMENT
WATERNODE
WATERSEGMENT

Planning Support Features

CONSTRUCTIONLINE
DOTPERMIT
EXTERNALPROPERTYINTEREST
GRID
PROJECTREFERENCE
SURVEYJOB
SURVEYPOINT

Site Support Features

BRIDGE
BUILDING
CONTROLMONUMENTPOINT
ELEVATIONCONTOUR
FENCE
GUARDRAIL
INSTALLATION
LANDPARCEL
PAVEMENTSECTION
RAILTRACK
RECREATIONAREA
RECREATIONFEATURE
RESTRICTEDAREA
ROADPATH
SIGN
SITE
STRUCTURE
TOWER
TRANSPORTATIONTUNNEL
WALL
WATERCOURSELINE
WATERFEATURE

Public Works Feature Tables

Table Name	COMMUNICATIONNODE
Feature Description	A subdivision of a communications network, particularly an asset that participates in the transmission of a signal but that is not a cable. For example, an amplifier, antenna, or splitter.

No	Field (Property)	Description
1	LABEL	Feature label or name
2	DESCRIPTION	Feature description
3	UTILITYOWNER	The direct owner of the feature
4	COMMNETWORKTYPE	Type of network that the feature is part of
5	COMMNODETYPE	Type of object that the feature is
6	QUALITYLEVEL	Information regarding the overall quality of the data
7	OPERATIONALSTATUS	Defined operational status of the feature
8	INVESTIGATIONLEVEL	Investigation level
9	CONFLICTID	Unique conflict ID
10	RESOLUTION	Resolution
11	RESOLUTIONSTATUS	Resolution status
12	DATEINSTALLED	Date installed
13	DATECHANGED	Date changed
14	SOURCEFILE	Related source file
15	SITEID	Unique identifier for the site location
16	OBJECTID	Unique database feature identifier
17	UTILITYNODETYPE	Utility Node Type for generating the graphics
18	FITTINGTYPE	Utility Fitting Type for generating the graphics
19	VOLUMETYPE	Utility Volumetric Type for generating the graphics
20	NODESHAPETYPE	Utility Node Shape Type for generating the graphics
21	LENGTH	Utility Node Length for generating the graphics
22	WIDTH	Utility Node Width for generating the graphics
23	HEIGHT	Utility Node Height for generating the graphics
24	ELEVATION	Utility Elevation for generating the graphics
25	ELEVATIONACCURACY	Utility Elevation Accuracy for generating the graphics
26	BOTTOMDIAMETER	Utility Node Bottom Diameter for generating the graphics
27	TOPDIAMETER	Utility Node Top Diameter for generating the graphics
28	COMMENTS	General notes and comments about the feature
29	OGC_GEOMETRY	GIS geometry
30	XFM_ID	Unique GIS feature identifier
31	MS_ANGLE	Feature display angle
32	MS_X_SCALE	Feature display x-scale
33	MS_Y_SCALE	Feature display y-scale

Table Name	COMMUNICATIONSEGMENT
Description	A subdivision of a communications network, particularly a cable for the transmission of a signal.

No	Field (Property)	Description
1	LABEL	Feature label or name
2	DESCRIPTION	Feature description
3	UTILITYOWNER	The direct owner of the feature
4	COMMNETWORKTYPE	Type of network that the feature is part of
5	COMMSEGMENTTYPE	Type of segment that the feature is
6	MATERIAL	Material of the feature
7	DIAMETER	Utility Segment Diameter for generating the graphics
8	MEASUREDLENGTH	Field verified length
9	QUALITYLEVEL	Information regarding the overall quality of the data
10	OPERATIONALSTATUS	Defined operational status of the feature
11	INVESTIGATIONLEVEL	Investigation level
12	CONFLICTID	Unique conflict ID
13	RESOLUTION	Resolution
14	RESOLUTIONSTATUS	Resolution status
15	DATEINSTALLED	Date installed
16	DATECHANGED	Date changed
17	SOURCEFILE	Related source file
18	SITEID	Unique identifier for the site location
19	OBJECTID	Unique database feature identifier
20	SEGMENTTYPE	Utility Segment Type for generating the graphics
21	SEGMENTSHAPETYPE	Utility Segment Shape Type for generating the graphics
22	RISE	Utility Segment Rise for generating the graphics
23	SPAN	Utility Segment Span for generating the graphics
24	BOTTOMWIDTH	Utility Segment Bottom Width for generating the graphics
25	RIGHTSIDESLOPE	Utility Segment Right Side Slope for generating the graphics
26	LEFTSIDESLOPE	Utility Segment Left Side Slope for generating the graphics
27	OFFSETEND	Offset End
28	OFFSETSTART	Offset Start
29	STATIONEND	Station End
30	STATIONSTART	Station Start
31	COMMENTS	General notes and comments about the feature
32	OGC_GEOMETRY	GIS geometry
33	XFM_ID	Unique GIS feature identifier

Table Name	CONFLICTNODE
Feature Description	A feature indicating and tracking conflicts between two utilities.

No	Field (Property)	Description
1	LABEL	Feature label or name
2	DESCRIPTION	Feature description
3	QUALITYLEVEL	Information regarding the overall quality of the data
4	CONFLICTID	Unique conflict ID
5	CONFLICTTYPE	Type of conflict
6	DEPTH	Depth at conflict
7	STATIONEND	Station End
8	STATIONSTART	Station Start
9	OFFSETEND	Offset End
10	OFFSETSTART	Offset Start
11	RESPONSIBLEPARTY	The parties (e.g., individuals, companies, or agencies) responsible for resolving the conflict
12	CONFLICTER	Unique ID of conflicting utility
13	CONFLICTEE	Unique ID of conflicting utility
14	CURRENTSTATUS	Current status of the conflict
15	RECOMMENDATION	Recommended conflict resolution
16	RESOLUTION	Conflict resolution
17	RESOLUTIONDESCR	Conflict resolution description or comments
19	SITEID	Unique identifier for the site location
20	OBJECTID	Unique database feature identifier
21	COMMENTS	General notes and comments about the feature
22	OGC_GEOMETRY	GIS geometry
23	XFM_ID	Unique GIS feature identifier
24	MS_ANGLE	Feature display angle
25	MS_X_SCALE	Feature display x-scale
26	MS_Y_SCALE	Feature display y-scale

Table Name	ELECONDUITBANKSEGMENT
Description	An assembly of electrical conduits.

No	Field (Property)	Description
1	LABEL	Feature label or name
2	DESCRIPTION	Feature description
3	UTILITYOWNER	The direct owner of the feature
4	ELECNETWORKTYPE	Type of network that the feature is part of
5	ELECSEGMENTTYPE	Electric Segment Type
6	MATERIAL	Material of the feature
7	DIAMETER	Utility Segment Diameter for generating the graphics
8	MEASUREDLENGTH	Field verified length
9	NUMBEROFCONDUITS	Number of conduits in bank
10	QUALITYLEVEL	Information regarding the overall quality of the data
11	OPERATIONALSTATUS	Defined operational status of the feature
12	INVESTIGATIONLEVEL	Investigation level
13	CONFLICTID	Unique conflict ID
14	RESOLUTION	Resolution
15	RESOLUTIONSTATUS	Resolution status
16	DATEINSTALLED	Date installed
17	DATECHANGED	Date changed
18	SOURCEFILE	Related source file
19	SITEID	Unique identifier for the site location
20	OBJECTID	Unique database feature identifier
21	SEGMENTTYPE	Utility Segment Type for generating the graphics
22	SEGMENTSHAPETYPE	Utility Segment Shape Type for generating the graphics
23	RISE	Utility Segment Rise for generating the graphics
24	SPAN	Utility Segment Span for generating the graphics
25	BOTTOMWIDTH	Utility Segment Bottom Width for generating the graphics
26	RIGHTSIDESLOPE	Utility Segment Right Side Slope for generating the graphics
27	LEFTHSIDESLOPE	Utility Segment Left Side Slope for generating the graphics
28	OFFSETEND	Offset end
29	OFFSETSTART	Offset start
30	STATIONEND	Station end
31	STATIONSTART	Station start
32	COMMENTS	General notes and comments about the feature
33	OGC_GEOMETRY	GIS geometry
34	XFM_ID	Unique GIS feature identifier

Table Name	ELECTRICALNODE
Description	A subdivision of an electrical distribution network, particularly an asset that participates in the transmission of electricity but that is not a line. For example, a transformer, fuse, generator, meter, or switch.

No	Field (Property)	Description
1	LABEL	Feature label or name
2	DESCRIPTION	Feature description
3	UTILITYOWNER	The direct owner of the feature
4	ELECNETWORKTYPE	Type of network that the feature is part of
5	ELECNODETYPE	Type of object that the feature is
6	QUALITYLEVEL	Information regarding the overall quality of the data
7	OPERATIONALSTATUS	Defined operational status of the feature
8	INVESTIGATIONLEVEL	Investigation level
9	CONFLICTID	Unique conflict ID
10	RESOLUTION	Resolution
11	RESOLUTIONSTATUS	Resolution status
12	DATEINSTALLED	Date installed
13	DATECHANGED	Date changed
14	SOURCEFILE	Related source file
15	SITEID	Unique identifier for the site location
16	OBJECTID	Unique database feature identifier
17	UTILITYNODETYPE	Utility Node Type for generating the graphics
18	FITTINGTYPE	Utility Fitting Type for generating the graphics
19	VOLUMETYPE	Utility Volumetric Type for generating the graphics
20	NODESHAPETYPE	Utility Node Shape Type for generating the graphics
21	LENGTH	Utility Node Length for generating the graphics
22	WIDTH	Utility Node Width for generating the graphics
23	HEIGHT	Utility Node Height for generating the graphics
24	ELEVATION	Utility Elevation for generating the graphics
25	ELEVATIONACCURACY	Utility Elevation Accuracy for generating the graphics
26	BOTTOMDIAMETER	Utility Node Bottom Diameter for generating the graphics
27	TOPDIAMETER	Utility Node Top Diameter for generating the graphics
28	COMMENTS	General notes and comments about the feature
29	OGC_GEOMETRY	GIS geometry
30	XFM_ID	Unique GIS feature identifier
31	MS_ANGLE	Feature display angle
32	MS_X_SCALE	Feature display x-scale
33	MS_Y_SCALE	Feature display y-scale

Table Name	ELECTRICALSEGMENT
Description	A subdivision of an electrical distribution network, particularly a line for the transmission of electricity.

No	Field (Property)	Description
1	LABEL	Feature label or name
2	DESCRIPTION	Feature description
3	UTILITYOWNER	The direct owner of the feature
4	ELECNETWORKTYPE	Type of network that the feature is part of
5	ELECSEGMENTTYPE	Electric Segment Type
6	MATERIAL	Material of the feature
7	DIAMETER	Utility Segment Diameter for generating the graphics
8	MEASUREDLENGTH	Field verified length
9	AVERAGEWIREGAUGE	Average wire gauge
10	IMPEDANCE	Electrical impedance
11	QUALITYLEVEL	Information regarding the overall quality of the data
12	OPERATIONALSTATUS	Defined operational status of the feature
13	INVESTIGATIONLEVEL	Investigation level
14	CONFLICTID	Unique conflict ID
15	RESOLUTION	Resolution
16	RESOLUTIONSTATUS	Resolution status
17	DATEINSTALLED	Date installed
18	DATECHANGED	Date changed
19	SOURCEFILE	Related source file
20	SITEID	Unique identifier for the site location
21	OBJECTID	Unique database feature identifier
22	SEGMENTTYPE	Utility Segment Type for generating the graphics
23	SEGMENTSHAPETYPE	Utility Segment Shape Type for generating the graphics
24	RISE	Utility Segment Rise for generating the graphics
25	SPAN	Utility Segment Span for generating the graphics
26	BOTTOMWIDTH	Utility Segment Bottom Width for generating the graphics
27	RIGHTSIDESLOPE	Utility Segment Right Side Slope for generating the graphics
28	LEFTSIDESLOPE	Utility Segment Left Side Slope for generating the graphics
29	OFFSETEND	Offset End
30	OFFSETSTART	Offset Start
31	STATIONEND	Station End
32	STATIONSTART	Station Start
33	COMMENTS	General notes and comments about the feature
34	OGC_GEOMETRY	GIS geometry
35	XFM_ID	Unique GIS feature identifier

Table Name	GASNODE
Description	A subdivision of a gas distribution network, particularly an asset that participates in the transmission of some heat or installation gas product but that is not a pipeline. For example, a pump, valve or fitting.

No	Field (Property)	Description
1	LABEL	Feature label or name
2	DESCRIPTION	Feature description
3	UTILITYOWNER	The direct owner of the feature
4	GASNETWORKTYPE	Type of network that the feature is part of
5	GASNODETYPE	Gas Node Type
6	QUALITYLEVEL	Information regarding the overall quality of the data
7	OPERATIONALSTATUS	Defined operational status of the feature
8	INVESTIGATIONLEVEL	Investigation level
9	CONFLICTID	Unique conflict ID
10	RESOLUTION	Resolution
11	RESOLUTIONSTATUS	Resolution status
12	DATEINSTALLED	Date installed
13	DATECHANGED	Date changed
14	SOURCEFILE	Related source file
15	SITEID	Unique identifier for the site location
16	OBJECTID	Unique database feature identifier
17	UTILITYNODETYPE	Utility Node Type for generating the graphics
18	FITTINGTYPE	Utility Fitting Type for generating the graphics
19	VOLUMETYPE	Utility Volumetric Type for generating the graphics
20	NODESHAPETYPE	Utility Node Shape Type for generating the graphics
21	LENGTH	Utility Node Length for generating the graphics
22	WIDTH	Utility Node Width for generating the graphics
23	HEIGHT	Utility Node Height for generating the graphics
24	ELEVATION	Utility Elevation for generating the graphics
25	ELEVATIONACCURACY	Utility Elevation Accuracy for generating the graphics
26	BOTTOMDIAMETER	Utility Node Bottom Diameter for generating the graphics
27	TOPDIAMETER	Utility Node Top Diameter for generating the graphics
28	COMMENTS	General notes and comments about the feature
29	OGC_GEOMETRY	GIS geometry
30	XFM_ID	Unique GIS feature identifier
31	MS_ANGLE	Feature display angle
32	MS_X_SCALE	Feature display x-scale
33	MS_Y_SCALE	Feature display y-scale

Table Name	GASSEGMENT
Description	A subdivision of a gas distribution network, particularly a pipeline for the transmission of some heat or installation gas product.

No	Field (Property)	Description
1	LABEL	Feature label or name
2	DESCRIPTION	Feature description
3	UTILITYOWNER	The direct owner of the feature
4	GASNETWORKTYPE	Type of network that the feature is part of
5	GASSEGMENTTYPE	Gas Segment Type
6	MATERIAL	Material of the feature
7	DIAMETER	Utility Segment Diameter for generating the graphics
8	INTERNALDIAMETER	Internal diameter
9	MEASUREDLENGTH	Field verified length
10	ROUGHNESSCOEFFICIENT	Roughness coefficient
11	QUALITYLEVEL	Information regarding the overall quality of the data
12	OPERATIONALSTATUS	Defined operational status of the feature
13	INVESTIGATIONLEVEL	Investigation level
14	CONFLICTID	Unique conflict ID
15	RESOLUTION	Resolution
16	RESOLUTIONSTATUS	Resolution status
17	DATEINSTALLED	Date installed
18	DATECHANGED	Date changed
19	SOURCEFILE	Related source file
20	SITEID	Unique identifier for the site location
21	OBJECTID	Unique database feature identifier
22	SEGMENTTYPE	Utility Segment Type for generating the graphics
23	SEGMENTSHAPETYPE	Utility Segment Shape Type for generating the graphics
24	RISE	Utility Segment Rise for generating the graphics
25	SPAN	Utility Segment Span for generating the graphics
26	BOTTOMWIDTH	Utility Segment Bottom Width for generating the graphics
27	RIGHTSIDESLOPE	Utility Segment Right Side Slope for generating the graphics
28	LEFTSIDESLOPE	Utility Segment Left Side Slope for generating the graphics
29	OFFSETEND	Offset End
30	OFFSETSTART	Offset Start
31	STATIONEND	Station End
32	STATIONSTART	Station Start
33	COMMENTS	General notes and comments about the feature
34	OGC_GEOMETRY	GIS geometry
35	XFM_ID	Unique GIS feature identifier

Table Name	POLNODE
Description	A subdivision of a POL distribution network, particularly an asset that participates in the transmission of some POL product but that is not a pipeline. For example, a pump, valve or fitting.

No	Field (Property)	Description
1	LABEL	Feature label or name
2	DESCRIPTION	Feature description
3	UTILITYOWNER	The direct owner of the feature
4	POLNETWORKTYPE	Type of network that the feature is part of
5	POLNODETYPE	POL Node Type
6	QUALITYLEVEL	Information regarding the overall quality of the data
7	OPERATIONALSTATUS	Defined operational status of the feature
8	INVESTIGATIONLEVEL	Investigation level
9	CONFLICTID	Unique conflict ID
10	RESOLUTION	Resolution
11	RESOLUTIONSTATUS	Resolution status
12	DATEINSTALLED	Date installed
13	DATECHANGED	Date changed
14	SOURCEFILE	Related source file
15	SITEID	Unique identifier for the site location
16	OBJECTID	Unique database feature identifier
17	UTILITYNODETYPE	Utility Node Type for generating the graphics
18	FITTINGTYPE	Utility Fitting Type for generating the graphics
19	VOLUMETYPE	Utility Volumetric Type for generating the graphics
20	NODESHAPETYPE	Utility Node Shape Type for generating the graphics
21	LENGTH	Utility Node Length for generating the graphics
22	WIDTH	Utility Node Width for generating the graphics
23	HEIGHT	Utility Node Height for generating the graphics
24	ELEVATION	Utility Elevation for generating the graphics
25	ELEVATIONACCURACY	Utility Elevation Accuracy for generating the graphics
26	BOTTOMDIAMETER	Utility Node Bottom Diameter for generating the graphics
27	TOPDIAMETER	Utility Node Top Diameter for generating the graphics
28	COMMENTS	General notes and comments about the feature
29	OGC_GEOMETRY	GIS geometry
30	XFM_ID	Unique GIS feature identifier
31	MS_ANGLE	Feature display angle
32	MS_X_SCALE	Feature display x-scale
33	MS_Y_SCALE	Feature display y-scale

Table Name	POLSEGMENT
Description	A subdivision of a POL distribution network, particularly a pipeline for the transmission of some POL product.

No	Field (Property)	Description
1	LABEL	Feature label or name
2	DESCRIPTION	Feature description
3	UTILITYOWNER	The direct owner of the feature
4	POLNETWORKTYPE	Type of network that the feature is part of
5	POLSEGMENTTYPE	POL Segment Type
6	MATERIAL	Material of the feature
7	DIAMETER	Utility Segment Diameter for generating the graphics
8	INTERNALDIAMETER	Internal diameter
9	MEASUREDLENGTH	Field verified length
10	ROUGHNESSCOEFFICIENT	Roughness coefficient
11	QUALITYLEVEL	Information regarding the overall quality of the data
12	OPERATIONALSTATUS	Defined operational status of the feature
13	INVESTIGATIONLEVEL	Investigation level
14	CONFLICTID	Unique conflict ID
15	RESOLUTION	Resolution
16	RESOLUTIONSTATUS	Resolution status
17	DATEINSTALLED	Date installed
18	DATECHANGED	Date changed
19	SOURCEFILE	Related source file
20	SITEID	Unique identifier for the site location
21	OBJECTID	Unique database feature identifier
22	SEGMENTTYPE	Utility Segment Type for generating the graphics
23	SEGMENTSHAPETYPE	Utility Segment Shape Type for generating the graphics
24	RISE	Utility Segment Rise for generating the graphics
25	SPAN	Utility Segment Span for generating the graphics
26	BOTTOMWIDTH	Utility Segment Bottom Width for generating the graphics
27	RIGHTSIDESLOPE	Utility Segment Right Side Slope for generating the graphics
28	LEFTHSIDESLOPE	Utility Segment Left Side Slope for generating the graphics
29	OFFSETEND	Offset End
30	OFFSETSTART	Offset Start
31	STATIONEND	Station End
32	STATIONSTART	Station Start
33	COMMENTS	General notes and comments about the feature
34	OGC_GEOMETRY	GIS geometry
35	XFM_ID	Unique GIS feature identifier

Table Name	THERMALNODE
Description	A nodes along a thermal distribution network, particularly a pipeline for the transmission of chilled water, refrigerant, hot water, or steam.

No	Field (Property)	Description
1	LABEL	Feature label or name
2	DESCRIPTION	Feature description
3	UTILITYOWNER	The direct owner of the feature
4	THERMALNETWORKTYPE	Type of network that the feature is part of
5	THERMALNODETYPE	Thermal Node Type
6	QUALITYLEVEL	Information regarding the overall quality of the data
7	OPERATIONALSTATUS	Defined operational status of the feature
8	INVESTIGATIONLEVEL	Investigation level
9	CONFLICTID	Unique conflict ID
10	RESOLUTION	Resolution
11	RESOLUTIONSTATUS	Resolution status
12	DATEINSTALLED	Date installed
13	DATECHANGED	Date changed
14	SOURCEFILE	Related source file
15	SITEID	Unique identifier for the site location
16	OBJECTID	Unique database feature identifier
17	UTILITYNODETYPE	Utility Node Type for generating the graphics
18	FITTINGTYPE	Utility Fitting Type for generating the graphics
19	VOLUMETYPE	Utility Volumetric Type for generating the graphics
20	NODESHAPETYPE	Utility Node Shape Type for generating the graphics
21	LENGTH	Utility Node Length for generating the graphics
22	WIDTH	Utility Node Width for generating the graphics
23	HEIGHT	Utility Node Height for generating the graphics
24	ELEVATION	Utility Elevation for generating the graphics
25	ELEVATIONACCURACY	Utility Elevation Accuracy for generating the graphics
26	BOTTOMDIAMETER	Utility Node Bottom Diameter for generating the graphics
27	TOPDIAMETER	Utility Node Top Diameter for generating the graphics
28	COMMENTS	General notes and comments about the feature
29	OGC_GEOMETRY	GIS geometry
30	XFM_ID	Unique GIS feature identifier
31	MS_ANGLE	Feature display angle
32	MS_X_SCALE	Feature display x-scale
33	MS_Y_SCALE	Feature display y-scale

Table Name	THERMALSEGMENT
Description	A subdivision of a thermal distribution network, particularly a pipeline for the transmission of chilled water, refrigerant, hot water, or steam.

No	Field (Property)	Description
1	LABEL	Feature label or name
2	DESCRIPTION	Feature description
3	UTILITYOWNER	The direct owner of the feature
4	THERMALNETWORKTYPE	Type of network that the feature is part of
5	THERMALSEGMENTTYPE	Thermal Segment Type
6	MATERIAL	Material of the feature
7	DIAMETER	Utility Segment Diameter for generating the graphics
8	INTERNALDIAMETER	Internal diameter
9	MEASUREDLENGTH	Field verified length
10	ROUGHNESSCOEFFICIENT	Roughness coefficient
11	QUALITYLEVEL	Information regarding the overall quality of the data
12	OPERATIONALSTATUS	Defined operational status of the feature
13	INVESTIGATIONLEVEL	Investigation level
14	CONFLICTID	Unique conflict ID
15	RESOLUTION	Resolution
16	RESOLUTIONSTATUS	Resolution status
17	DATEINSTALLED	Date installed
18	DATECHANGED	Date changed
19	SOURCEFILE	Related source file
20	SITEID	Unique identifier for the site location
21	OBJECTID	Unique database feature identifier
22	SEGMENTTYPE	Utility Segment Type for generating the graphics
23	SEGMENTSHAPETYPE	Utility Segment Shape Type for generating the graphics
24	RISE	Utility Segment Rise for generating the graphics
25	SPAN	Utility Segment Span for generating the graphics
26	BOTTOMWIDTH	Utility Segment Bottom Width for generating the graphics
27	RIGHTSIDESLOPE	Utility Segment Right Side Slope for generating the graphics
28	LEFTSIDESLOPE	Utility Segment Left Side Slope for generating the graphics
29	OFFSETEND	Offset End
30	OFFSETSTART	Offset Start
31	STATIONEND	Station End
32	STATIONSTART	Station Start
33	COMMENTS	General notes and comments about the feature
34	OGC_GEOMETRY	GIS geometry
35	XFM_ID	Unique GIS feature identifier

Table Name	UTILITYFEATURE
Description	Generic utility feature.

No	Field (Property)	Description
1	LABEL	Feature label or name
2	DESCRIPTION	Feature description
3	UTILITYOWNER	The direct owner of the feature
4	NETWORKTYPE	Type of network that the feature is part of
5	NETWORKSUBTYPE	Subtype of network that the feature is part of
6	UTILITYFEATURETYPE	Utility feature type
7	QUALITYLEVEL	Information regarding the overall quality of the data
8	OPERATIONALSTATUS	Defined operational status of the feature
9	INVESTIGATIONLEVEL	Investigation level
10	CONFLICTID	Unique conflict ID
11	RESOLUTION	Resolution
12	RESOLUTIONSTATUS	Resolution status
13	DATEINSTALLED	Date installed
14	DATECHANGED	Date changed
15	SOURCEFILE	Related source file
16	SITEID	Unique identifier for the site location
17	OBJECTID	Unique database feature identifier
18	COMMENTS	General notes and comments about the feature
19	OGC_GEOMETRY	GIS geometry
20	XFM_ID	Unique GIS feature identifier

Table Name	WASTEWATERNODE
Description	A subdivision of a wastewater network, particularly an asset that participates in the handling of stormwater, sewage or industrial wastewater, but that is not a pipeline. For example, a pump, holding facility, and/or treatment facility.

No	Field (Property)	Description
1	LABEL	Feature label or name
2	DESCRIPTION	Feature description
3	UTILITYOWNER	The direct owner of the feature
4	WWATERNETWORKTYPE	Type of network that the feature is part of
5	WWATERNODETYPE	Waste Water Node Type
6	QUALITYLEVEL	Information regarding the overall quality of the data
7	OPERATIONALSTATUS	Defined operational status of the feature
8	INVESTIGATIONLEVEL	Investigation level
9	CONFLICTID	Unique conflict ID
10	RESOLUTION	Resolution
11	RESOLUTIONSTATUS	Resolution status
12	DATEINSTALLED	Date installed
13	DATECHANGED	Date changed
14	SOURCEFILE	Related source file
15	SITEID	Unique identifier for the site location
16	OBJECTID	Unique database feature identifier
17	UTILITYNODETYPE	Utility Node Type for generating the graphics
18	FITTINGTYPE	Utility Fitting Type for generating the graphics
19	VOLUMETYPE	Utility Volumetric Type for generating the graphics
20	NODESHAPETYPE	Utility Node Shape Type for generating the graphics
21	LENGTH	Utility Node Length for generating the graphics
22	WIDTH	Utility Node Width for generating the graphics
23	HEIGHT	Utility Node Height for generating the graphics
24	ELEVATION	Utility Elevation for generating the graphics
25	ELEVATIONACCURACY	Utility Elevation Accuracy for generating the graphics
26	BOTTOMDIAMETER	Utility Node Bottom Diameter for generating the graphics
27	TOPDIAMETER	Utility Node Top Diameter for generating the graphics
28	COMMENTS	General notes and comments about the feature
29	OGC_GEOMETRY	GIS geometry
30	XFM_ID	Unique GIS feature identifier
31	MS_ANGLE	Feature display angle
32	MS_X_SCALE	Feature display x-scale
33	MS_Y_SCALE	Feature display y-scale

Table Name	WASTEWATERSEGMENT
Description	A subdivision of a wastewater network, particularly a pipeline for the transport of stormwater, sewage or industrial waste between the source, holding facilities, and/or treatment facilities.

No	Field (Property)	Description
1	LABEL	Feature label or name
2	DESCRIPTION	Feature description
3	UTILITYOWNER	The direct owner of the feature
4	WWATERNETWORKTYPE	Type of network that the feature is part of
5	WWATERSEGMENTTYPE	Waste Water Segment Type
6	MATERIAL	Material of the feature
7	DIAMETER	Utility Segment Diameter for generating the graphics
8	INTERNALDIAMETER	Internal diameter
9	MEASUREDLENGTH	Field verified length
10	ROUGHNESSCOEFFICIENT	Roughness coefficient
11	QUALITYLEVEL	Information regarding the overall quality of the data
12	OPERATIONALSTATUS	Defined operational status of the feature
13	INVESTIGATIONLEVEL	Investigation level
14	CONFLICTID	Unique conflict ID
15	RESOLUTION	Resolution
16	RESOLUTIONSTATUS	Resolution status
17	DATEINSTALLED	Date installed
18	DATECHANGED	Date changed
19	SOURCEFILE	Related source file
20	SITEID	Unique identifier for the site location
21	OBJECTID	Unique database feature identifier
22	COMMENTS	General notes and comments about the feature
23	OGC_GEOMETRY	GIS geometry
24	XFM_ID	Unique GIS feature identifier

Table Name	WATERFEATURE
Description	A cartographic representation of surface water in any form.

No	Field (Property)	Description
1	LABEL	Feature label or name
2	DESCRIPTION	Feature description
3	UTILITYOWNER	The direct owner of the feature
4	WATERNETWORKTYPE	Type of network that the feature is part of
5	WATERNODETYPE	Water Node Type
6	QUALITYLEVEL	Information regarding the overall quality of the data
7	OPERATIONALSTATUS	Defined operational status of the feature
8	INVESTIGATIONLEVEL	Investigation level
9	CONFLICTID	Unique conflict ID
10	RESOLUTION	Resolution
11	RESOLUTIONSTATUS	Resolution status
12	DATEINSTALLED	Date installed
13	DATECHANGED	Date changed
14	SOURCEFILE	Related source file
15	SITEID	Unique identifier for the site location
16	OBJECTID	Unique database feature identifier
17	COMMENTS	General notes and comments about the feature
18	OGC_GEOMETRY	GIS geometry
19	XFM_ID	Unique GIS feature identifier

Table Name	WATERNODE
Description	A subdivision of a water distribution network, particularly an asset that participates in the transmission of water but that is not a pipeline. For example, a pump, valve or fitting.

No	Field (Property)	Description
1	LABEL	Feature label or name
2	DESCRIPTION	Feature description
3	UTILITYOWNER	The direct owner of the feature
4	WATERNETWORKTYPE	Type of network that the feature is part of
5	WATERNODETYPE	Water Node Type
6	QUALITYLEVEL	Information regarding the overall quality of the data
7	OPERATIONALSTATUS	Defined operational status of the feature
8	INVESTIGATIONLEVEL	Investigation level
9	CONFLICTID	Unique conflict ID
10	RESOLUTION	Resolution
11	RESOLUTIONSTATUS	Resolution status
12	DATEINSTALLED	Date installed
13	DATECHANGED	Date changed
14	SOURCEFILE	Related source file
15	SITEID	Unique identifier for the site location
16	OBJECTID	Unique database feature identifier
17	UTILITYNODETYPE	Utility Node Type for generating the graphics
18	FITTINGTYPE	Utility Fitting Type for generating the graphics
19	VOLUMETYPE	Utility Volumetric Type for generating the graphics
20	NODESHAPETYPE	Utility Node Shape Type for generating the graphics
21	LENGTH	Utility Node Length for generating the graphics
22	WIDTH	Utility Node Width for generating the graphics
23	HEIGHT	Utility Node Height for generating the graphics
24	ELEVATION	Utility Elevation for generating the graphics
25	ELEVATIONACCURACY	Utility Elevation Accuracy for generating the graphics
26	BOTTOMDIAMETER	Utility Node Bottom Diameter for generating the graphics
27	TOPDIAMETER	Utility Node Top Diameter for generating the graphics
28	COMMENTS	General notes and comments about the feature
29	OGC_GEOMETRY	GIS geometry
30	XFM_ID	Unique GIS feature identifier
31	MS_ANGLE	Feature display angle
32	MS_X_SCALE	Feature display x-scale
33	MS_Y_SCALE	Feature display y-scale

Planning Support Features

Table Name	CONSTRUCTIONLINE
Description	Survey construction line.

No	Field (Property)	Description
1	LABEL	Feature label or name
2	DESCRIPTION	Feature description
3	UTILITYOWNER	The direct owner of the feature
4	QUALITYLEVEL	Information regarding the overall quality of the data
5	OPERATIONALSTATUS	Defined operational status of the feature
6	INVESTIGATIONLEVEL	Investigation level
7	CONFLICTID	Unique conflict ID
8	RESOLUTION	Resolution
9	RESOLUTIONSTATUS	Resolution status
10	DATEINSTALLED	Date installed
11	DATECHANGED	Date changed
12	SOURCEFILE	Related source file
13	SITEID	Unique identifier for the site location
14	OBJECTID	Unique database feature identifier
15	COMMENTS	General notes and comments about the feature
16	OGC_GEOMETRY	GIS geometry
17	XFM_ID	Unique GIS feature identifier

Table Name	DOTPERMIT
Description	Permit issued by the DOT.

No	Field (Property)	Description
1	LABEL	Feature label or name
2	DESCRIPTION	Feature description
3	UTILITYOWNER	The direct owner of the feature
4	QUALITYLEVEL	Information regarding the overall quality of the data
5	OPERATIONALSTATUS	Defined operational status of the feature
6	INVESTIGATIONLEVEL	Investigation level
7	CONFLICTID	Unique conflict ID
8	RESOLUTION	Resolution
9	RESOLUTIONSTATUS	Resolution status
10	DATEISSUED	Date permit was issued
11	DATECHANGED	Date changed
12	SOURCEFILE	Related source file
13	SITEID	Unique identifier for the site location
14	OBJECTID	Unique database feature identifier
15	COMMENTS	General notes and comments about the feature
16	OGC_GEOMETRY	GIS geometry
17	XFM_ID	Unique GIS feature identifier

Table Name	EXTERNALPROPERTYINTEREST
Description	Interests in land held by external entities.

No	Field (Property)	Description
1	LABEL	Feature label or name
2	DESCRIPTION	Feature description
3	UTILITYOWNER	The direct owner of the feature
4	INTERESTTYPE	Interest Type
5	QUALITYLEVEL	Information regarding the overall quality of the data
6	OPERATIONALSTATUS	Defined operational status of the feature
7	INVESTIGATIONLEVEL	Investigation level
8	CONFLICTID	Unique conflict ID
9	RESOLUTION	Resolution
10	RESOLUTIONSTATUS	Resolution status
11	DATEINSTALLED	Date installed
12	DATECHANGED	Date changed
13	SOURCEFILE	Related source file
14	SITEID	Unique identifier for the site location
15	OBJECTID	Unique database feature identifier
16	COMMENTS	General notes and comments about the feature
17	OGC_GEOMETRY	GIS geometry
18	XFM_ID	Unique GIS feature identifier

Table Name	GRID
Description	A regular pattern of polygons that represent arbitrary delineations of an area. This can be used for locator grids or reference to the footprint of an orthorectified photograph.

No	Field (Property)	Description
1	LABEL	Feature label or name
2	DESCRIPTION	Feature description
3	UTILITYOWNER	The direct owner of the feature
4	QUALITYLEVEL	Information regarding the overall quality of the data
5	OPERATIONALSTATUS	Defined operational status of the feature
6	INVESTIGATIONLEVEL	Investigation level
7	CONFLICTID	Unique conflict ID
8	RESOLUTION	Resolution
9	RESOLUTIONSTATUS	Resolution status
10	DATEINSTALLED	Date installed
11	DATECHANGED	Date changed
12	SOURCEFILE	Related source file
13	SITEID	Unique identifier for the site location
14	OBJECTID	Unique database feature identifier
15	COMMENTS	General notes and comments about the feature
16	OGC_GEOMETRY	GIS geometry
17	XFM_ID	Unique GIS feature identifier

Table Name	PROJECTREFERENCE
Description	Project Reference

No	Field (Property)	Description
1	LABEL	Feature label or name
2	DESCRIPTION	Feature description
3	UTILITYOWNER	The direct owner of the feature
4	PROJECTID	Foreign key reference to a project identifier used by an external business system.
5	QUALITYLEVEL	Information regarding the overall quality of the data
6	OPERATIONALSTATUS	Defined operational status of the feature
7	INVESTIGATIONLEVEL	Investigation level
8	CONFLICTID	Unique conflict ID
9	RESOLUTION	Resolution
10	RESOLUTIONSTATUS	Resolution status
11	DATEINSTALLED	Date installed
12	DATECHANGED	Date changed
13	SOURCEFILE	Related source file
14	SITEID	Unique identifier for the site location
15	OBJECTID	Unique database feature identifier
16	COMMENTS	General notes and comments about the feature
17	OGC_GEOMETRY	GIS geometry
18	XFM_ID	Unique GIS feature identifier

Table Name	SURVEYJOB
Description	Generic area in which a survey activity was conducted.

No	Field (Property)	Description
1	LABEL	Feature label or name
2	DESCRIPTION	Feature description
3	UTILITYOWNER	The direct owner of the feature
4	SURVEYTYPE	Type of survey
5	SURVEYMETHOD	Survey method used
6	QUALITYLEVEL	Information regarding the overall quality of the data
7	OPERATIONALSTATUS	Defined operational status of the feature
8	INVESTIGATIONLEVEL	Investigation level
9	CONFLICTID	Unique conflict ID
10	RESOLUTION	Resolution
11	RESOLUTIONSTATUS	Resolution status
12	DATEINSTALLED	Date installed
13	DATECHANGED	Date changed
14	SOURCEFILE	Related source file
15	SITEID	Unique identifier for the site location
16	OBJECTID	Unique database feature identifier
17	COMMENTS	General notes and comments about the feature
18	OGC_GEOMETRY	GIS geometry
19	XFM_ID	Unique GIS feature identifier

Table Name	SURVEYPOINT
Description	Location of survey activity.

No	Field (Property)	Description
1	LABEL	Feature label or name
2	DESCRIPTION	Feature description
3	UTILITYOWNER	The direct owner of the feature
4	SOURCETYPE	Source Type for the survey
5	QUALITYLEVEL	Information regarding the overall quality of the data
6	OPERATIONALSTATUS	Defined operational status of the feature
7	INVESTIGATIONLEVEL	Investigation level
8	CONFLICTID	Unique conflict ID
9	RESOLUTION	Resolution
10	RESOLUTIONSTATUS	Resolution status
11	DATEINSTALLED	Date installed
12	DATECHANGED	Date changed
13	SOURCEFILE	Related source file
14	SITEID	Unique identifier for the site location
15	OBJECTID	Unique database feature identifier
16	COMMENTS	General notes and comments about the feature
17	OGC_GEOMETRY	GIS geometry
18	XFM_ID	Unique GIS feature identifier
19	MS_ANGLE	Feature display angle
20	MS_X_SCALE	Feature display x-scale
21	MS_Y_SCALE	Feature display y-scale

Site Support Features

Table Name	BRIDGE
Feature Description	A structure used by vehicles that allows passage over or under an obstacle such as a river, chasm, mountain, road or railroad.

No	Field (Property)	Description
1	LABEL	Feature label or name
2	DESCRIPTION	Feature description
3	UTILITYOWNER	The direct owner of the feature
4	BRIDGETYPE	The type of bridge
5	HORIZONTALCLEARANCE	Horizontal clearance
6	HORIZONTALCLEARANCEUOM	The horizontal clearance units of measure
7	ISFIXED	Indicator of whether or not the bridge can be opened for navigation (or other purposes)
8	LOWCHORDELEVATION	Low Chord Elevation
9	LOWCHORDELEVATIONUOM	Low chord elevation units of measurement
10	REFERENCEELEVATION	Reference elevation
11	REFERENCEELEVDESCRIPTION	Description of the reference elevation. This attribute should be used to define what the reference elevation refers to in the physical world, such as top of water surface at mean flow.
12	REFERENCEELEVUOM	Reference elevation units of measurement
13	REFERENCEELEVVERTDATUM	Reference elevation vertical datum
14	TOPWIDTH	Top width
15	VERTCLEARANCECLOSED	Vertical clearance closed
16	VERTCLEARANCECLOSEDUOM	Vertical clearance closed units of measure
17	VERTCLEARANCEOPEN	Vertical clearance opened
18	VERTCLEARANCEOPENUOM	Vertical clearance opened units of measure
19	QUALITYLEVEL	Information regarding the overall quality of the data
20	OPERATIONALSTATUS	Defined operational status of the feature
21	INVESTIGATIONLEVEL	Investigation level
22	CONFLICTID	Unique conflict ID
23	RESOLUTION	Resolution
24	RESOLUTIONSTATUS	Resolution status
25	DATEINSTALLED	Date installed
26	DATECHANGED	Date changed
27	SOURCEFILE	Related source file
28	SITEID	Unique identifier for the site location
29	OBJECTID	Unique database feature identifier
30	COMMENTS	General notes and comments about the feature
31	OGC_GEOMETRY	GIS geometry
32	XFM_ID	Unique GIS feature identifier

Table Name	BUILDING
Feature Description	A roofed, floored and walled structure that is completely enclosed.

No	Field (Property)	Description
1	LABEL	Feature label or name
2	DESCRIPTION	Feature description
3	UTILITYOWNER	The direct owner of the feature
4	QUALITYLEVEL	Information regarding the overall quality of the data
5	OPERATIONALSTATUS	Defined operational status of the feature
6	INVESTIGATIONLEVEL	Investigation level
7	CONFLICTID	Unique conflict ID
8	RESOLUTION	Resolution
9	RESOLUTIONSTATUS	Resolution status
10	DATEINSTALLED	Date installed
11	DATECHANGED	Date changed
12	SOURCEFILE	Related source file
13	SITEID	Unique identifier for the site location
14	OBJECTID	Unique database feature identifier
15	COMMENTS	General notes and comments about the feature
16	OGC_GEOMETRY	GIS geometry
17	XFM_ID	Unique GIS feature identifier

Table Name	CONTROLMONUMENTPOINT
Description	A geographic or manmade feature such as a monument, building, or other structure that is used for the development of position bearings.

No	Field (Property)	Description
1	LABEL	Feature label or name
2	DESCRIPTION	Feature description
3	UTILITYOWNER	The direct owner of the feature
4	HORIZONTALDATUM	Horizontal datum
5	COLLECTIONVERTICALDATUM	Collection Vertical Datum
6	MONUMENTPOINTTYPE	Type of monument point
7	COORDINATESYSTEM	Coordinate System
8	QUALITYLEVEL	Information regarding the overall quality of the data
9	OPERATIONALSTATUS	Defined operational status of the feature
10	INVESTIGATIONLEVEL	Investigation level
11	CONFLICTID	Unique conflict ID
12	RESOLUTION	Resolution
13	RESOLUTIONSTATUS	Resolution status
14	DATEINSTALLED	Date installed
15	EPOCDATE	EPOC Date
16	SOURCEFILE	Related source file
17	SITEID	Unique identifier for the site location
18	OBJECTID	Unique database feature identifier
19	COMMENTS	General notes and comments about the feature
20	OGC_GEOMETRY	GIS geometry
21	XFM_ID	Unique GIS feature identifier
22	MS_ANGLE	Feature display angle
23	MS_X_SCALE	Feature display x-scale
24	MS_Y_SCALE	Feature display y-scale

Table Name	ELEVATIONCONTOUR
Description	A line of constant value indicating elevation relative to some reference system and unit of measure.

No	Field (Property)	Description
1	LABEL	Feature label or name
2	DESCRIPTION	Feature description
3	UTILITYOWNER	The direct owner of the feature
4	CONTOURELEVATION	Contour Elevation
5	ELEVATIONUOM	Elevation Units Of Measurement
6	ELEVCONTOURTYPE	Elevation Contour Type
7	QUALITYLEVEL	Information regarding the overall quality of the data
8	OPERATIONALSTATUS	Defined operational status of the feature
9	INVESTIGATIONLEVEL	Investigation level
10	CONFLICTID	Unique conflict ID
11	RESOLUTION	Resolution
12	RESOLUTIONSTATUS	Resolution status
13	DATEINSTALLED	Date installed
14	DATECHANGED	Date changed
15	SOURCEFILE	Related source file
16	SITEID	Unique identifier for the site location
17	OBJECTID	Unique database feature identifier
18	COMMENTS	General notes and comments about the feature
19	OGC_GEOMETRY	GIS geometry
20	XFM_ID	Unique GIS feature identifier

Table Name	FENCE
Description	A freestanding structure designed to restrict or prevent movement across a boundary. It is generally distinguished from a wall by the solidity of construction: a wall is usually restricted to such barriers made from solid brick or concrete.

No	Field (Property)	Description
1	LABEL	Feature label or name
2	DESCRIPTION	Feature description
3	UTILITYOWNER	The direct owner of the feature
4	FENCEUSE	Primary use for the fence
5	QUALITYLEVEL	Information regarding the overall quality of the data
6	OPERATIONALSTATUS	Defined operational status of the feature
7	INVESTIGATIONLEVEL	Investigation level
8	CONFLICTID	Unique conflict ID
9	RESOLUTION	Resolution
10	RESOLUTIONSTATUS	Resolution status
11	DATEINSTALLED	Date installed
12	DATECHANGED	Date changed
13	SOURCEFILE	Related source file
14	SITEID	Unique identifier for the site location
15	OBJECTID	Unique database feature identifier
16	COMMENTS	General notes and comments about the feature
17	OGC_GEOMETRY	GIS geometry
18	XFM_ID	Unique GIS feature identifier

Table Name	GUARDRAIL
Description	A barrier generally placed along the edge of a roadway.

No	Field (Property)	Description
1	LABEL	Feature label or name
2	DESCRIPTION	Feature description
3	UTILITYOWNER	The direct owner of the feature
4	GUARDMATERIAL	Guard Material
5	GUARDHEIGHT	Guardrail Height
6	HEIGHTUOM	Height Units Of Measurement
7	QUALITYLEVEL	Information regarding the overall quality of the data
8	OPERATIONALSTATUS	Defined operational status of the feature
9	INVESTIGATIONLEVEL	Investigation level
10	CONFLICTID	Unique conflict ID
11	RESOLUTION	Resolution
12	RESOLUTIONSTATUS	Resolution status
13	DATEINSTALLED	Date installed
14	DATECHANGED	Date changed
15	SOURCEFILE	Related source file
16	SITEID	Unique identifier for the site location
17	OBJECTID	Unique database feature identifier
18	COMMENTS	General notes and comments about the feature
19	OGC_GEOMETRY	GIS geometry
20	XFM_ID	Unique GIS feature identifier

Table Name	INSTALLATION
Description	A single site or a grouping of two or more sites for real property inventory reporting.

No	Field (Property)	Description
1	LABEL	Feature label or name
2	DESCRIPTION	Feature description
3	UTILITYOWNER	The direct owner of the feature
4	DATERECORDED	Date on which the composition of the final installation polygon was extracted.
5	QUALITYLEVEL	Information regarding the overall quality of the data
6	OPERATIONALSTATUS	Defined operational status of the feature
7	INVESTIGATIONLEVEL	Investigation level
8	CONFLICTID	Unique conflict ID
9	RESOLUTION	Resolution
10	RESOLUTIONSTATUS	Resolution status
11	DATEINSTALLED	Date installed
12	DATECHANGED	Date changed
13	SOURCEFILE	Related source file
14	SITEID	Unique identifier for the site location
15	OBJECTID	Unique database feature identifier
16	COMMENTS	General notes and comments about the feature
17	OGC_GEOMETRY	GIS geometry
18	XFM_ID	Unique GIS feature identifier

Table Name	LANDPARCEL
Description	A parcel is a specific area of land.

No	Field (Property)	Description
1	LABEL	Feature label or name
2	DESCRIPTION	Feature description
3	UTILITYOWNER	The direct owner of the feature
4	QUALITYLEVEL	Information regarding the overall quality of the data
5	OPERATIONALSTATUS	Defined operational status of the feature
6	INVESTIGATIONLEVEL	Investigation level
7	CONFLICTID	Unique conflict ID
8	RESOLUTION	Resolution
9	RESOLUTIONSTATUS	Resolution status
10	DATEINSTALLED	Date installed
11	DATECHANGED	Date changed
12	SOURCEFILE	Related source file
13	SITEID	Unique identifier for the site location
14	OBJECTID	Unique database feature identifier
15	COMMENTS	General notes and comments about the feature
16	OGC_GEOMETRY	GIS geometry
17	XFM_ID	Unique GIS feature identifier

Table Name	PAVEMENTSECTION
Description	A pavement section is a portion of a pavement branch that differs in some aspect from other sections such that further segmentation is required to uniquely identify that section.

No	Field (Property)	Description
1	LABEL	Feature label or name
2	DESCRIPTION	Feature description
3	UTILITYOWNER	The direct owner of the feature
4	PAVEMENTSECTIONTYPE	Pavement section type
5	QUALITYLEVEL	Information regarding the overall quality of the data
6	OPERATIONALSTATUS	Defined operational status of the feature
7	INVESTIGATIONLEVEL	Investigation level
8	CONFLICTID	Unique conflict ID
9	RESOLUTION	Resolution
10	RESOLUTIONSTATUS	Resolution status
11	DATEINSTALLED	Date installed
12	DATECHANGED	Date changed
13	SOURCEFILE	Related source file
14	SITEID	Unique identifier for the site location
15	OBJECTID	Unique database feature identifier
16	COMMENTS	General notes and comments about the feature
17	OGC_GEOMETRY	GIS geometry
18	XFM_ID	Unique GIS feature identifier

Table Name	RAILTRACK
Description	A track is the main designation for describing a physical linear portion of the network.

No	Field (Property)	Description
1	LABEL	Feature label or name
2	DESCRIPTION	Feature description
3	UTILITYOWNER	The direct owner of the feature
4	RAILCONSTRUCTIONTYPE	Rail Construction Type
5	QUALITYLEVEL	Information regarding the overall quality of the data
6	OPERATIONALSTATUS	Defined operational status of the feature
7	INVESTIGATIONLEVEL	Investigation level
8	CONFLICTID	Unique conflict ID
9	RESOLUTION	Resolution
10	RESOLUTIONSTATUS	Resolution status
11	DATEINSTALLED	Date installed
12	DATECHANGED	Date changed
13	SOURCEFILE	Related source file
14	SITEID	Unique identifier for the site location
15	OBJECTID	Unique database feature identifier
16	COMMENTS	General notes and comments about the feature
17	OGC_GEOMETRY	GIS geometry
18	XFM_ID	Unique GIS feature identifier

Table Name	RECREATIONAREA
Description	An area defined for recreational purposes.

No	Field (Property)	Description
1	LABEL	Feature label or name
2	DESCRIPTION	Feature description
3	UTILITYOWNER	The direct owner of the feature
4	AREATYPE	Area Type
5	QUALITYLEVEL	Information regarding the overall quality of the data
6	OPERATIONALSTATUS	Defined operational status of the feature
7	INVESTIGATIONLEVEL	Investigation level
8	CONFLICTID	Unique conflict ID
9	RESOLUTION	Resolution
10	RESOLUTIONSTATUS	Resolution status
11	DATEINSTALLED	Date installed
12	DATECHANGED	Date changed
13	SOURCEFILE	Related source file
14	SITEID	Unique identifier for the site location
15	OBJECTID	Unique database feature identifier
16	COMMENTS	General notes and comments about the feature
17	OGC_GEOMETRY	GIS geometry
18	XFM_ID	Unique GIS feature identifier

Table Name	RECREATIONFEATURE
Description	A feature defined for recreational purposes.

No	Field (Property)	Description
1	LABEL	Feature label or name
2	DESCRIPTION	Feature description
3	UTILITYOWNER	The direct owner of the feature
4	QUALITYLEVEL	Information regarding the overall quality of the data
5	OPERATIONALSTATUS	Defined operational status of the feature
6	INVESTIGATIONLEVEL	Investigation level
7	CONFLICTID	Unique conflict ID
8	RESOLUTION	Resolution
9	RESOLUTIONSTATUS	Resolution status
10	DATEINSTALLED	Date installed
11	DATECHANGED	Date changed
12	SOURCEFILE	Related source file
13	SITEID	Unique identifier for the site location
14	OBJECTID	Unique database feature identifier
15	COMMENTS	General notes and comments about the feature
16	OGC_GEOMETRY	GIS geometry
17	XFM_ID	Unique GIS feature identifier
18	MS_ANGLE	Feature display angle
19	MS_X_SCALE	Feature display x-scale
20	MS_Y_SCALE	Feature display y-scale

Table Name	RESTRICTEDAREA
Description	Restrictions placed on or near revetments.

No	Field (Property)	Description
1	LABEL	Feature label or name
2	DESCRIPTION	Feature description
3	UTILITYOWNER	The direct owner of the feature
4	RESTRICTIONDESCRIPTION	Description of the restriction.
5	QUALITYLEVEL	Information regarding the overall quality of the data
6	OPERATIONALSTATUS	Defined operational status of the feature
7	INVESTIGATIONLEVEL	Investigation level
8	CONFLICTID	Unique conflict ID
9	RESOLUTION	Resolution
10	RESOLUTIONSTATUS	Resolution status
11	DATEINSTALLED	Date installed
12	DATECHANGED	Date changed
13	SOURCEFILE	Related source file
14	SITEID	Unique identifier for the site location
15	OBJECTID	Unique database feature identifier
16	COMMENTS	General notes and comments about the feature
17	OGC_GEOMETRY	GIS geometry
18	XFM_ID	Unique GIS feature identifier

Table Name	ROADPATH
Description	Linear, possibly discontinuous, portion of the road network.

No	Field (Property)	Description
1	LABEL	Feature label or name
2	DESCRIPTION	Feature description
3	UTILITYOWNER	The direct owner of the feature
4	ROUTENAME	Public identifier, a name such as Elm Street or Route 66.
5	QUALITYLEVEL	Information regarding the overall quality of the data
6	OPERATIONALSTATUS	Defined operational status of the feature
7	INVESTIGATIONLEVEL	Investigation level
8	CONFLICTID	Unique conflict ID
9	RESOLUTION	Resolution
10	RESOLUTIONSTATUS	Resolution status
11	DATEINSTALLED	Date installed
12	DATECHANGED	Date changed
13	SOURCEFILE	Related source file
14	SITEID	Unique identifier for the site location
15	OBJECTID	Unique database feature identifier
16	COMMENTS	General notes and comments about the feature
17	OGC_GEOMETRY	GIS geometry
18	XFM_ID	Unique GIS feature identifier

Table Name	SIGN
Description	Signs erected at the side of or above roads to provide information.

No	Field (Property)	Description
1	LABEL	Feature label or name
2	DESCRIPTION	Feature description
3	UTILITYOWNER	The direct owner of the feature
4	SIGNTYPE	Sign Type
5	QUALITYLEVEL	Information regarding the overall quality of the data
6	OPERATIONALSTATUS	Defined operational status of the feature
7	INVESTIGATIONLEVEL	Investigation level
8	CONFLICTID	Unique conflict ID
9	RESOLUTION	Resolution
10	RESOLUTIONSTATUS	Resolution status
11	DATEINSTALLED	Date installed
12	DATECHANGED	Date changed
13	SOURCEFILE	Related source file
14	SITEID	Unique identifier for the site location
15	OBJECTID	Unique database feature identifier
16	COMMENTS	General notes and comments about the feature
17	OGC_GEOMETRY	GIS geometry
18	XFM_ID	Unique GIS feature identifier
19	MS_ANGLE	Feature display angle
20	MS_X_SCALE	Feature display x-scale
21	MS_Y_SCALE	Feature display y-scale

Table Name	SITE
Description	A physical location owned, leased, or otherwise possessed.

No	Field (Property)	Description
1	LABEL	Feature label or name
2	DESCRIPTION	Feature description
3	UTILITYOWNER	The direct owner of the feature
4	QUALITYLEVEL	Information regarding the overall quality of the data
5	OPERATIONALSTATUS	Defined operational status of the feature
6	INVESTIGATIONLEVEL	Investigation level
7	CONFLICTID	Unique conflict ID
8	RESOLUTION	Resolution
9	RESOLUTIONSTATUS	Resolution status
10	DATEINSTALLED	Date installed
11	DATECHANGED	Date changed
12	SOURCEFILE	Related source file
13	SITEID	Unique identifier for the site location
14	OBJECTID	Unique database feature identifier
15	COMMENTS	General notes and comments about the feature
16	OGC_GEOMETRY	GIS geometry
17	XFM_ID	Unique GIS feature identifier

Table Name	STRUCTURE
Description	A facility classified as other than a building or linear asset.

No	Field (Property)	Description
1	LABEL	Feature label or name
2	DESCRIPTION	Feature description
3	UTILITYOWNER	The direct owner of the feature
4	QUALITYLEVEL	Information regarding the overall quality of the data
5	OPERATIONALSTATUS	Defined operational status of the feature
6	INVESTIGATIONLEVEL	Investigation level
7	CONFLICTID	Unique conflict ID
8	RESOLUTION	Resolution
9	RESOLUTIONSTATUS	Resolution status
10	DATEINSTALLED	Date installed
11	DATECHANGED	Date changed
12	SOURCEFILE	Related source file
13	SITEID	Unique identifier for the site location
14	OBJECTID	Unique database feature identifier
15	COMMENTS	General notes and comments about the feature
16	OGC_GEOMETRY	GIS geometry
17	XFM_ID	Unique GIS feature identifier

Table Name	TOWER
Description	A vertical projection, higher than its diameter, generally used for observation, storage, or electronic transmission. Examples are a fire tower, water tower, telecommunications tower, etc.

No	Field (Property)	Description
1	LABEL	Feature label or name
2	DESCRIPTION	Feature description
3	UTILITYOWNER	The direct owner of the feature
4	FACILITYNAME	Commonly used name for the facility.
5	HEIGHTMAX	Height Max
6	HEIGHTUOM	Tower height Units Of Measurement
7	TOWERCONDITION	Tower Condition
8	TOWERMATERIAL	Tower Material
9	TOWERUSETYPE	Tower Use Type
10	QUALITYLEVEL	Information regarding the overall quality of the data
11	OPERATIONALSTATUS	Defined operational status of the feature
12	INVESTIGATIONLEVEL	Investigation level
13	CONFLICTID	Unique conflict ID
14	RESOLUTION	Resolution
15	RESOLUTIONSTATUS	Resolution status
16	DATEINSTALLED	Date installed
17	DATECHANGED	Date changed
18	SOURCEFILE	Related source file
19	SITEID	Unique identifier for the site location
20	OBJECTID	Unique database feature identifier
21	COMMENTS	General notes and comments about the feature
22	OGC_GEOMETRY	GIS geometry
23	XFM_ID	Unique GIS feature identifier
24	MS_ANGLE	Feature display angle
25	MS_X_SCALE	Feature display x-scale
26	MS_Y_SCALE	Feature display y-scale

Table Name	TRANSPORTATIONTUNNEL
Description	The area of a transportation passage, open at both ends, used to provide access through or under a natural obstacle.

No	Field (Property)	Description
1	LABEL	Feature label or name
2	DESCRIPTION	Feature description
3	UTILITYOWNER	The direct owner of the feature
4	AVERAGEHEIGHT	Average Height
5	AVERAGEWIDTH	Average Width
6	NAICSCODE	NAICS Code
7	TUNNELLENGTH	Tunnel Length
8	TUNNELTYPE	Tunnel Type
9	VERTCLEARANCE	Feature vertical clearance
10	QUALITYLEVEL	Information regarding the overall quality of the data
11	OPERATIONALSTATUS	Defined operational status of the feature
12	INVESTIGATIONLEVEL	Investigation level
13	CONFLICTID	Unique conflict ID
14	RESOLUTION	Resolution
15	RESOLUTIONSTATUS	Resolution status
16	DATEINSTALLED	Date installed
17	DATECHANGED	Date changed
18	SOURCEFILE	Related source file
19	SITEID	Unique identifier for the site location
20	OBJECTID	Unique database feature identifier
21	COMMENTS	General notes and comments about the feature
22	OGC_GEOMETRY	GIS geometry
23	XFM_ID	Unique GIS feature identifier

Table Name	WALL
Description	A freestanding structure designed to restrict or prevent movement across a boundary, usually restricted to such barriers made from solid brick or concrete.

No	Field (Property)	Description
1	LABEL	Feature label or name
2	DESCRIPTION	Feature description
3	UTILITYOWNER	The direct owner of the feature
4	WALLHEIGHT	Wall Height
5	WALLHEIGHTUOM	Wall Height Units Of Measurement
6	WALLTYPE	Wall Type
7	QUALITYLEVEL	Information regarding the overall quality of the data
8	OPERATIONALSTATUS	Defined operational status of the feature
9	INVESTIGATIONLEVEL	Investigation level
10	CONFLICTID	Unique conflict ID
11	RESOLUTION	Resolution
12	RESOLUTIONSTATUS	Resolution status
13	DATEINSTALLED	Date installed
14	DATECHANGED	Date changed
15	SOURCEFILE	Related source file
16	SITEID	Unique identifier for the site location
17	OBJECTID	Unique database feature identifier
18	COMMENTS	General notes and comments about the feature
19	OGC_GEOMETRY	GIS geometry
20	XFM_ID	Unique GIS feature identifier

Table Name	WATERCOURSELINE
Description	A HydroLine defining a reach of a naturally occurring watercourse (e.g., creek, stream, river).

No	Field (Property)	Description
1	LABEL	Feature label or name
2	DESCRIPTION	Feature description
3	UTILITYOWNER	The direct owner of the feature
4	WATERCOURSEELEMENT	Water Course Element
5	HYDROCODE	Hydro Code
6	ISNAVIGABLE	Indicator whether the line designates a navigable portion of the watercourse.
7	QUALITYLEVEL	Information regarding the overall quality of the data
8	OPERATIONALSTATUS	Defined operational status of the feature
9	INVESTIGATIONLEVEL	Investigation level
10	CONFLICTID	Unique conflict ID
11	RESOLUTION	Resolution
12	RESOLUTIONSTATUS	Resolution status
13	DATEINSTALLED	Date installed
14	DATECHANGED	Date changed
15	SOURCEFILE	Related source file
16	SITEID	Unique identifier for the site location
17	OBJECTID	Unique database feature identifier
18	COMMENTS	General notes and comments about the feature
19	OGC_GEOMETRY	GIS geometry
20	XFM_ID	Unique GIS feature identifier

Table Name	WATERSEGMENT
Description	A subdivision of a water distribution network, particularly a distribution pipeline.

No	Field (Property)	Description
1	LABEL	Feature label or name
2	DESCRIPTION	Feature description
3	UTILITYOWNER	The direct owner of the feature
4	WATERSEGMENTTYPE	Water Segment Type
5	WATERNETWORKTYPE	Type of network that the feature is part of
6	MATERIAL	Material of the feature
7	DIAMETER	Utility Segment Diameter for generating the graphics
8	INTERNALDIAMETER	Internal diameter
9	MEASUREDLENGTH	Field verified length
10	ROUGHNESSCOEFFICIENT	Roughness coefficient
11	QUALITYLEVEL	Information regarding the overall quality of the data
12	OPERATIONALSTATUS	Defined operational status of the feature
13	INVESTIGATIONLEVEL	Investigation level
14	CONFLICTID	Unique conflict ID
15	RESOLUTION	Resolution
16	RESOLUTIONSTATUS	Resolution status
17	DATEINSTALLED	Date installed
18	DATECHANGED	Date changed
19	SOURCEFILE	Related source file
20	SITEID	Unique identifier for the site location
21	OBJECTID	Unique database feature identifier
22	SEGMENTTYPE	Utility Segment Type for generating the graphics
23	SEGMENTSHAPETYPE	Utility Segment Shape Type for generating the graphics
24	RISE	Utility Segment Rise for generating the graphics
25	SPAN	Utility Segment Span for generating the graphics
26	BOTTOMWIDTH	Utility Segment Bottom Width for generating the graphics
27	RIGHTSIDESLOPE	Utility Segment Right Side Slope for generating the graphics
28	LEFTSIDESLOPE	Utility Segment Left Side Slope for generating the graphics
29	OFFSETEND	Offset End
30	OFFSETSTART	Offset Start
31	STATIONEND	Station End
32	STATIONSTART	Station Start
33	COMMENTS	General notes and comments about the feature
34	OGC_GEOMETRY	GIS geometry
35	XFM_ID	Unique GIS feature identifier

Table ERD Diagrams

BRIDGE

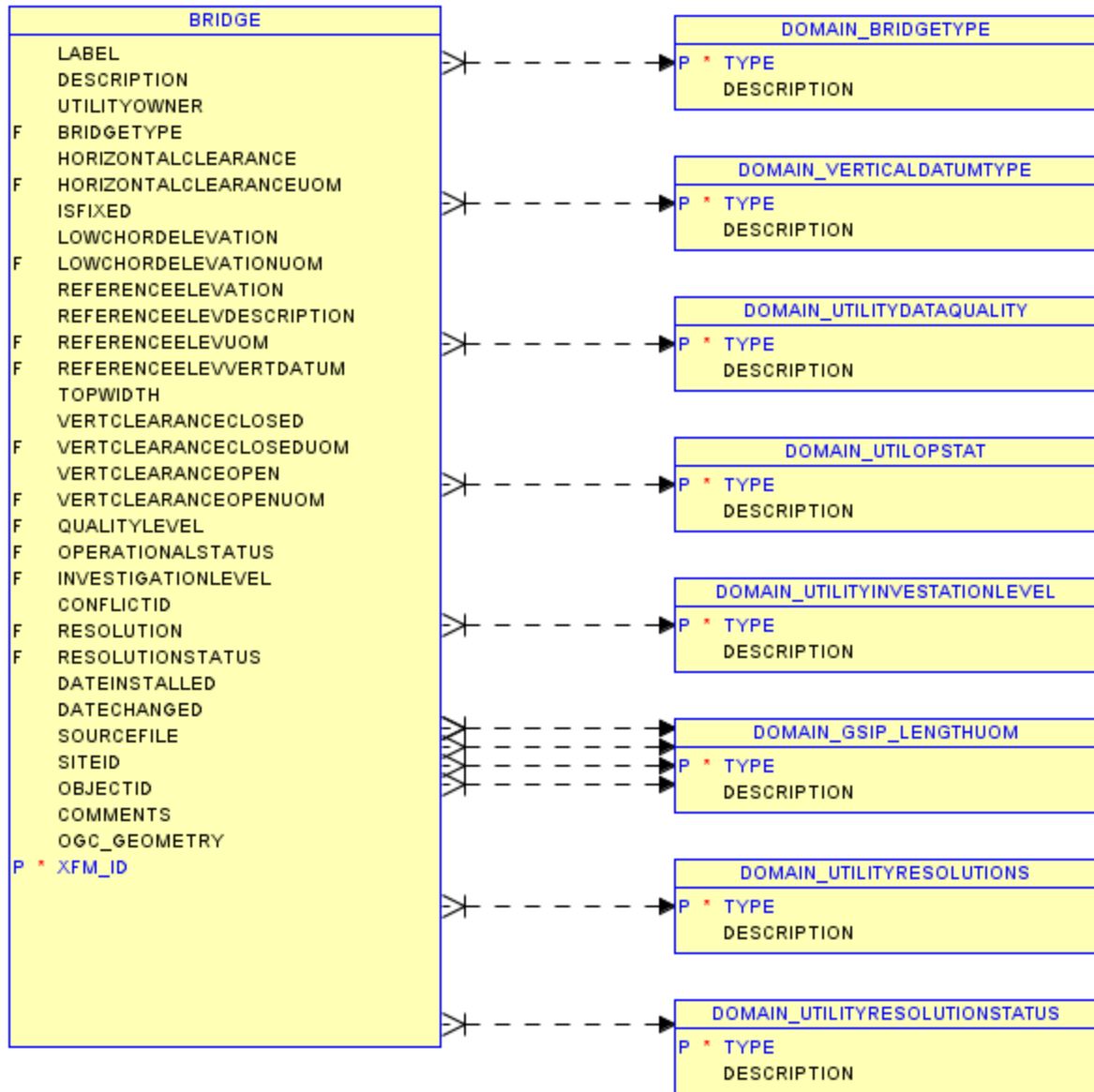

BUILDING

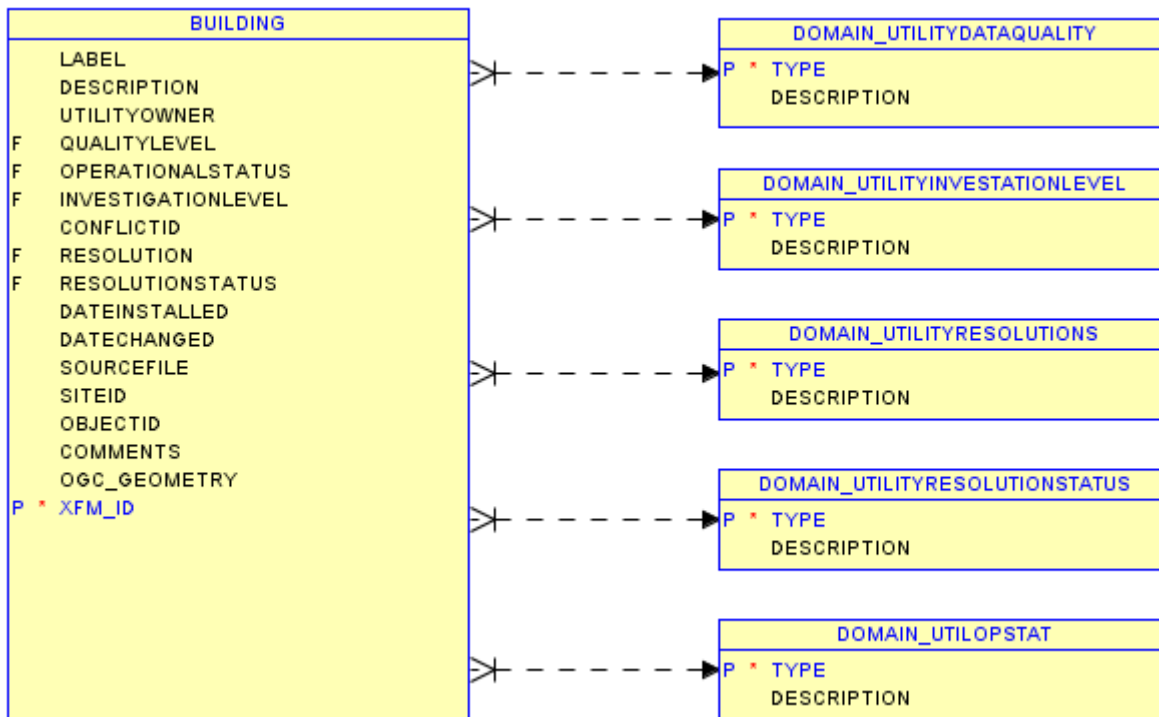

COMMUNICATIONNODE

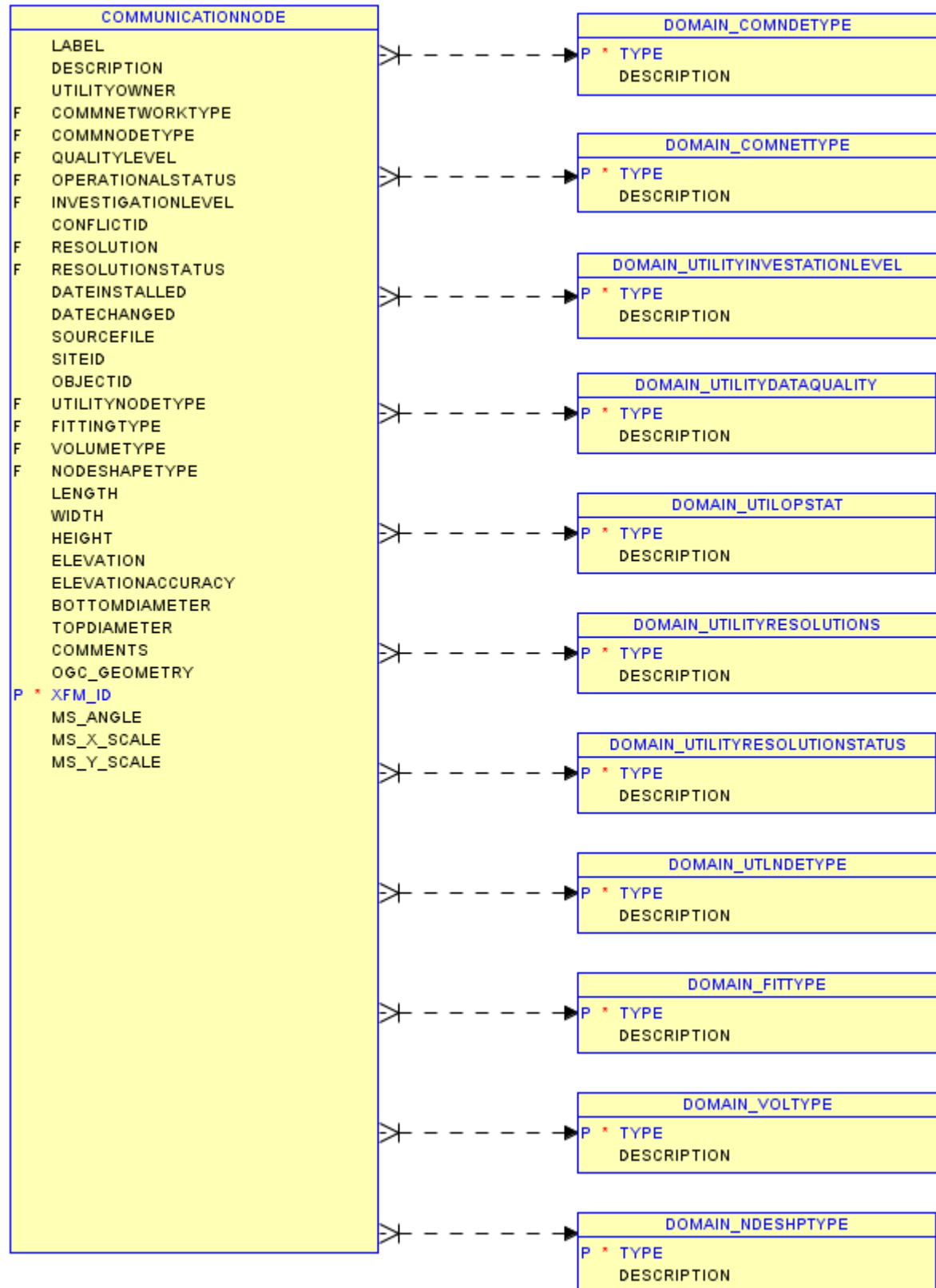

COMMUNICATIONSEGMENT



CONFLICTNODE

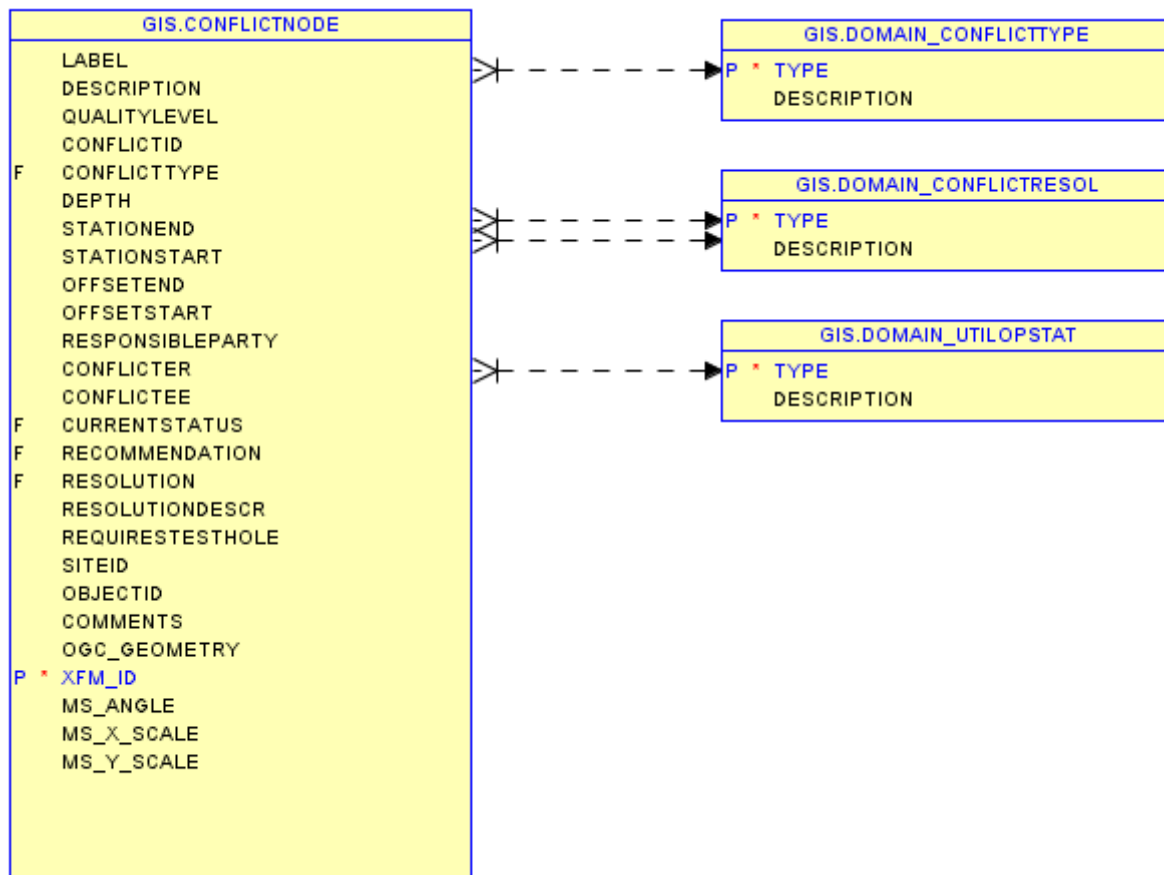

CONSTRUCTIONLINE

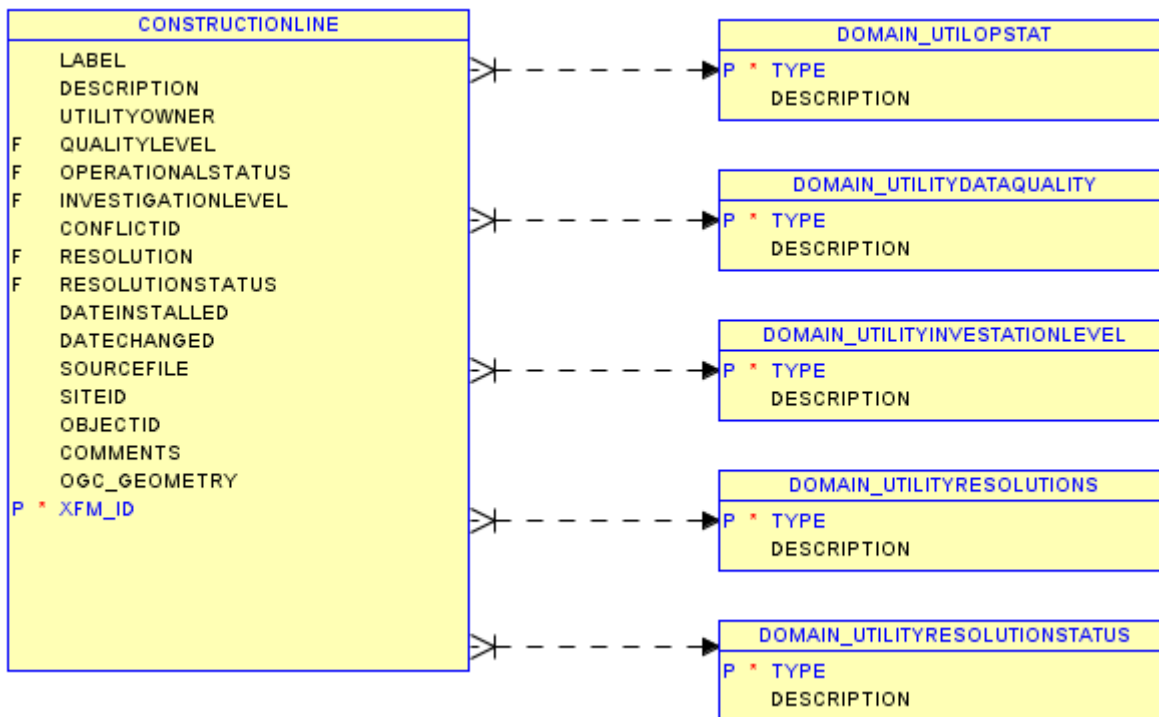

CONTROLMONUMENTPOINT

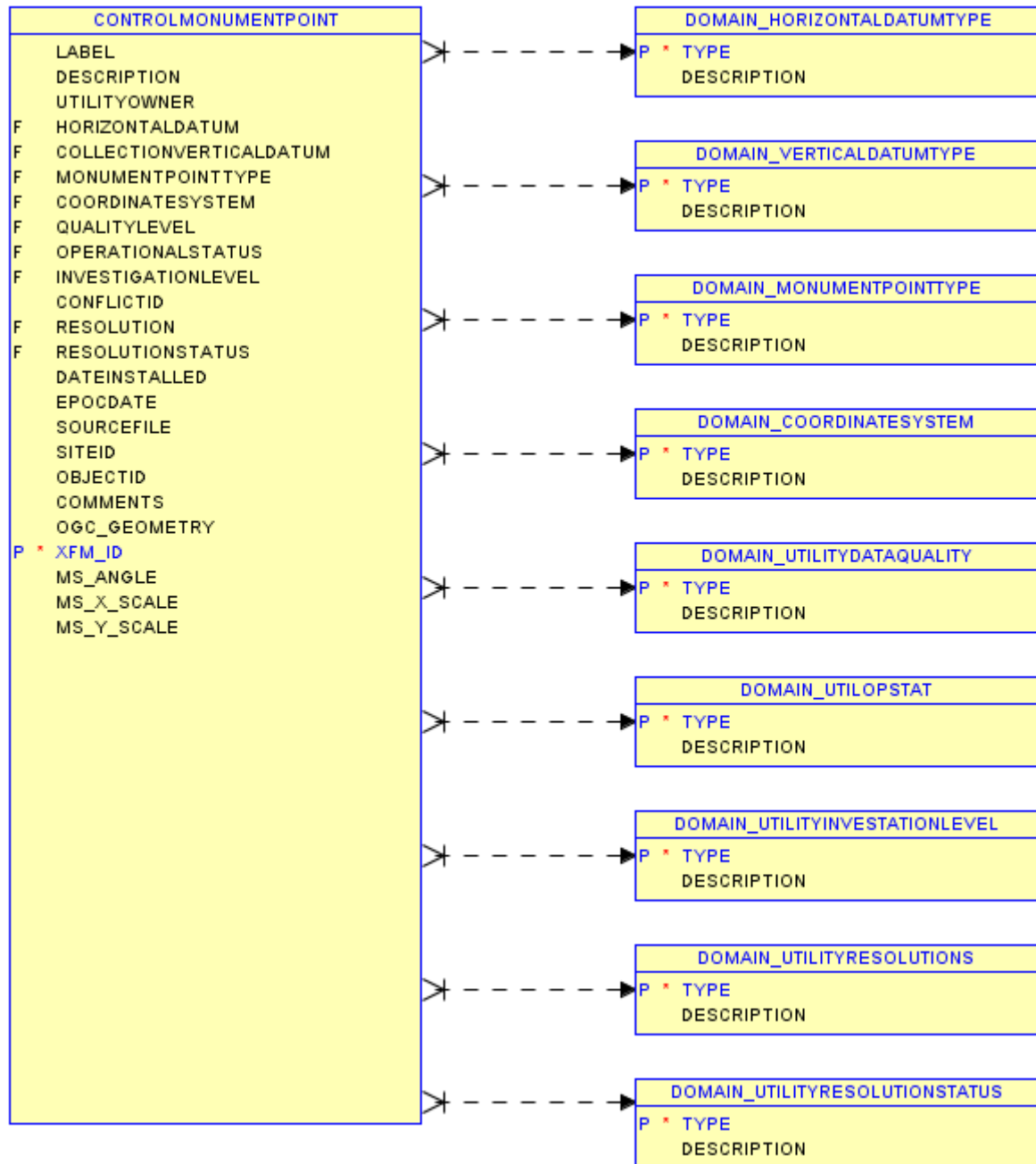

DOTPERMIT

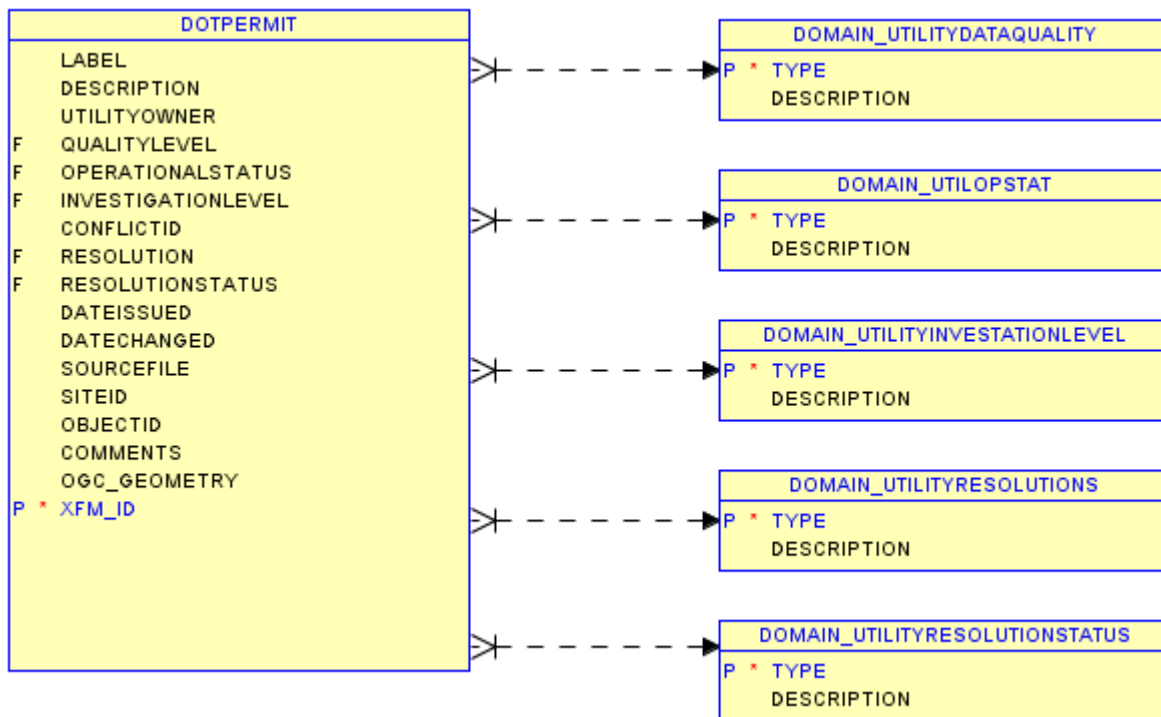

ELECCONDUITBANKSEGMENT

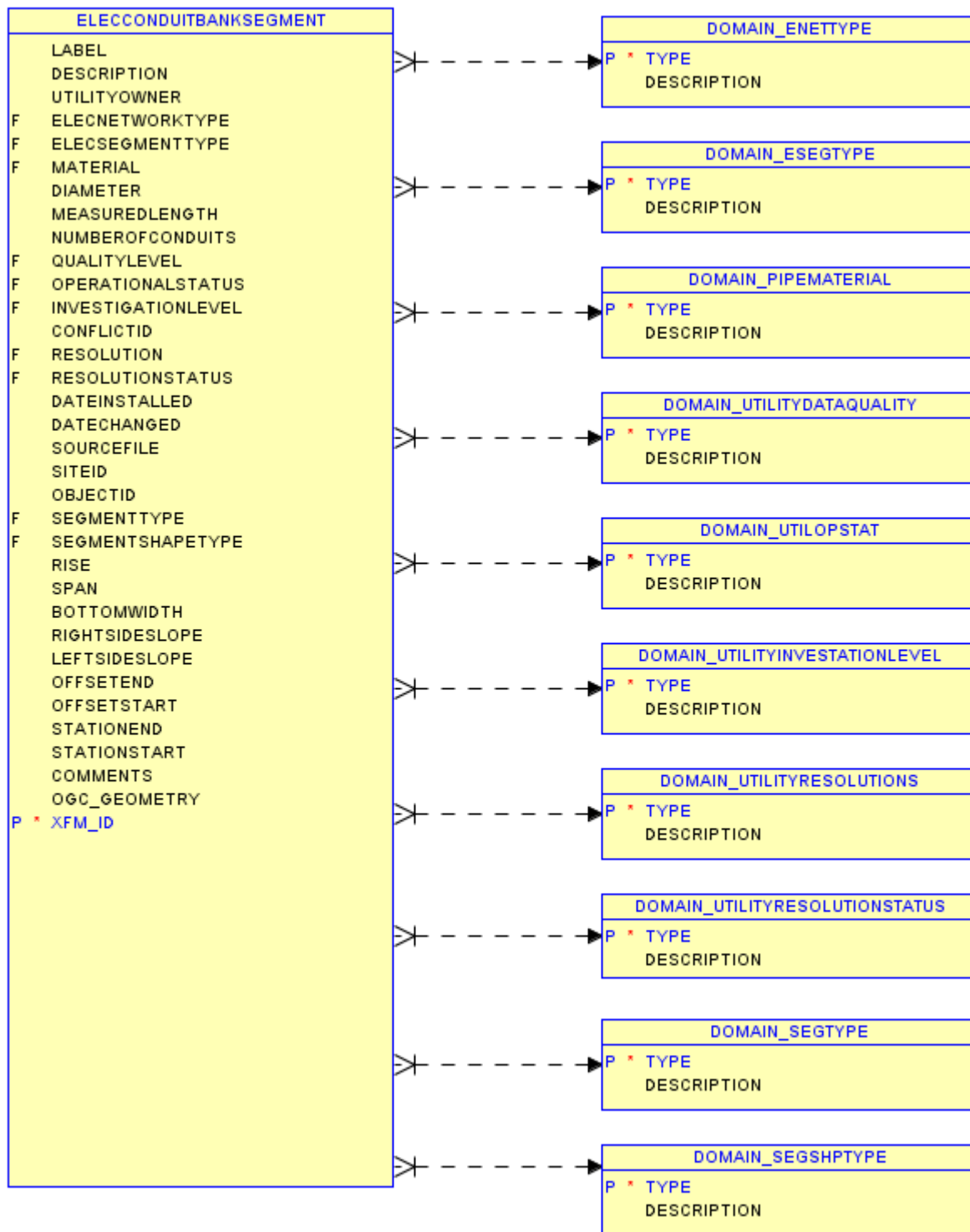

ELECTRICALNODE

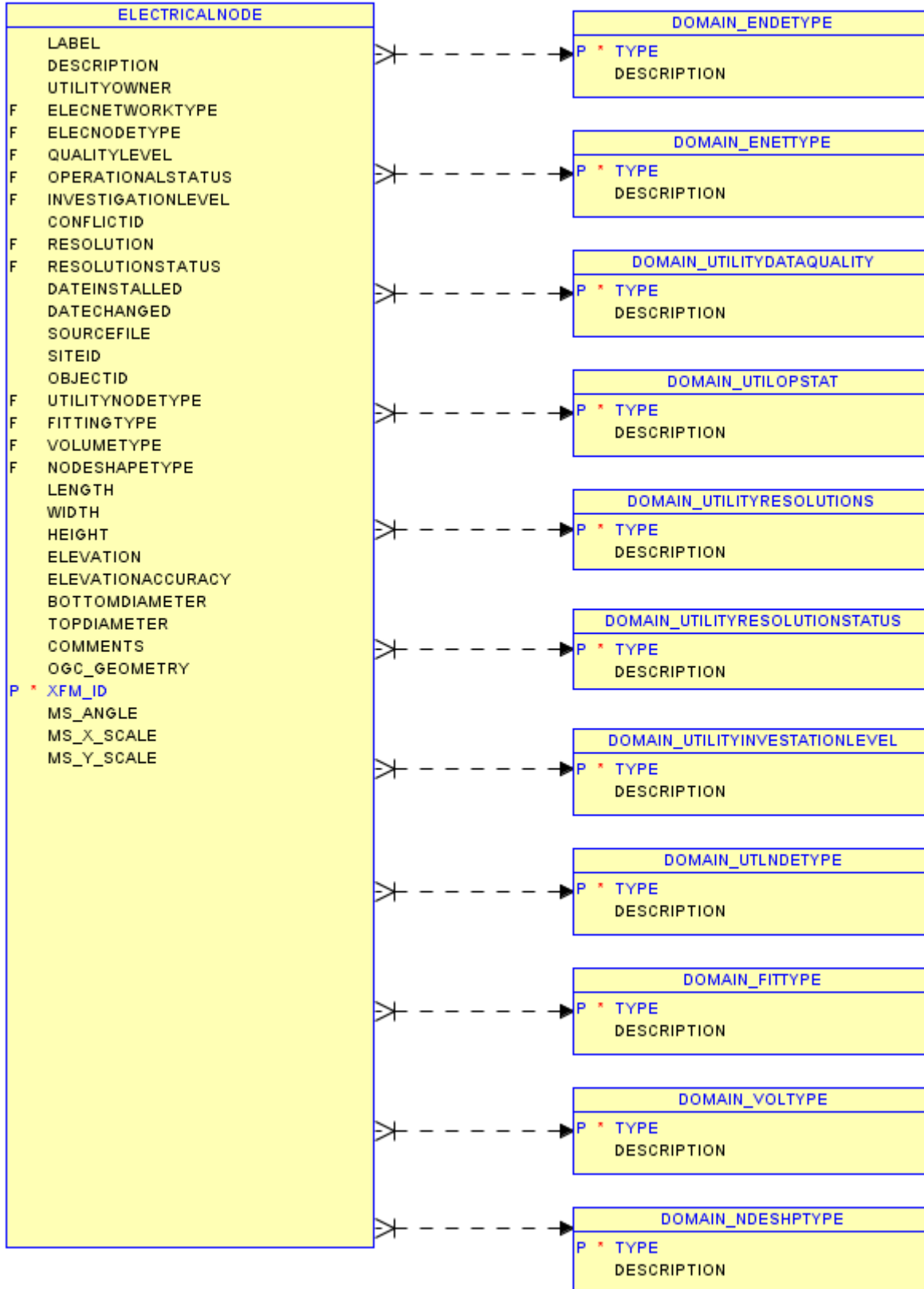

ELECTRICALSEGMENT

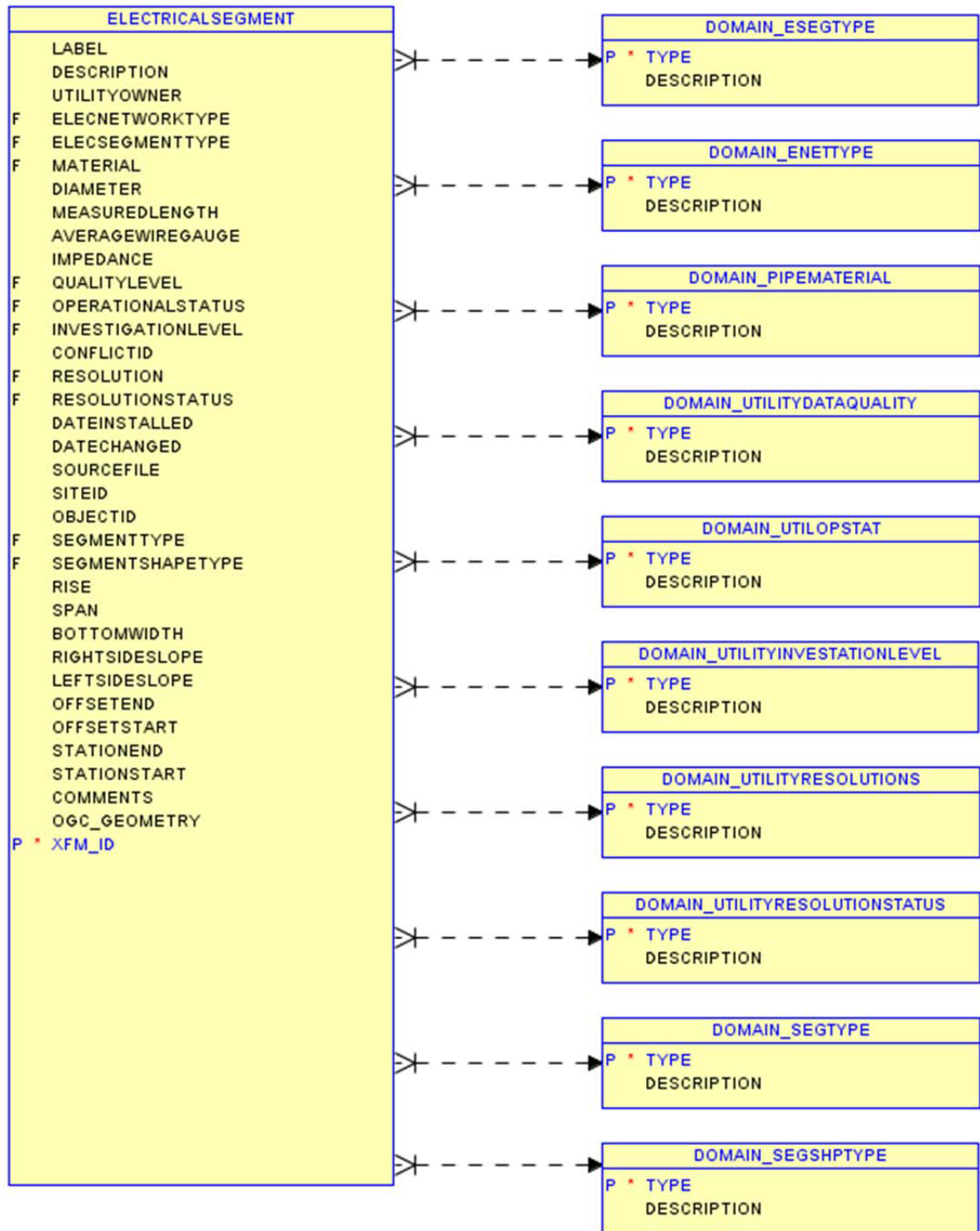

ELEVATIONCONTOUR

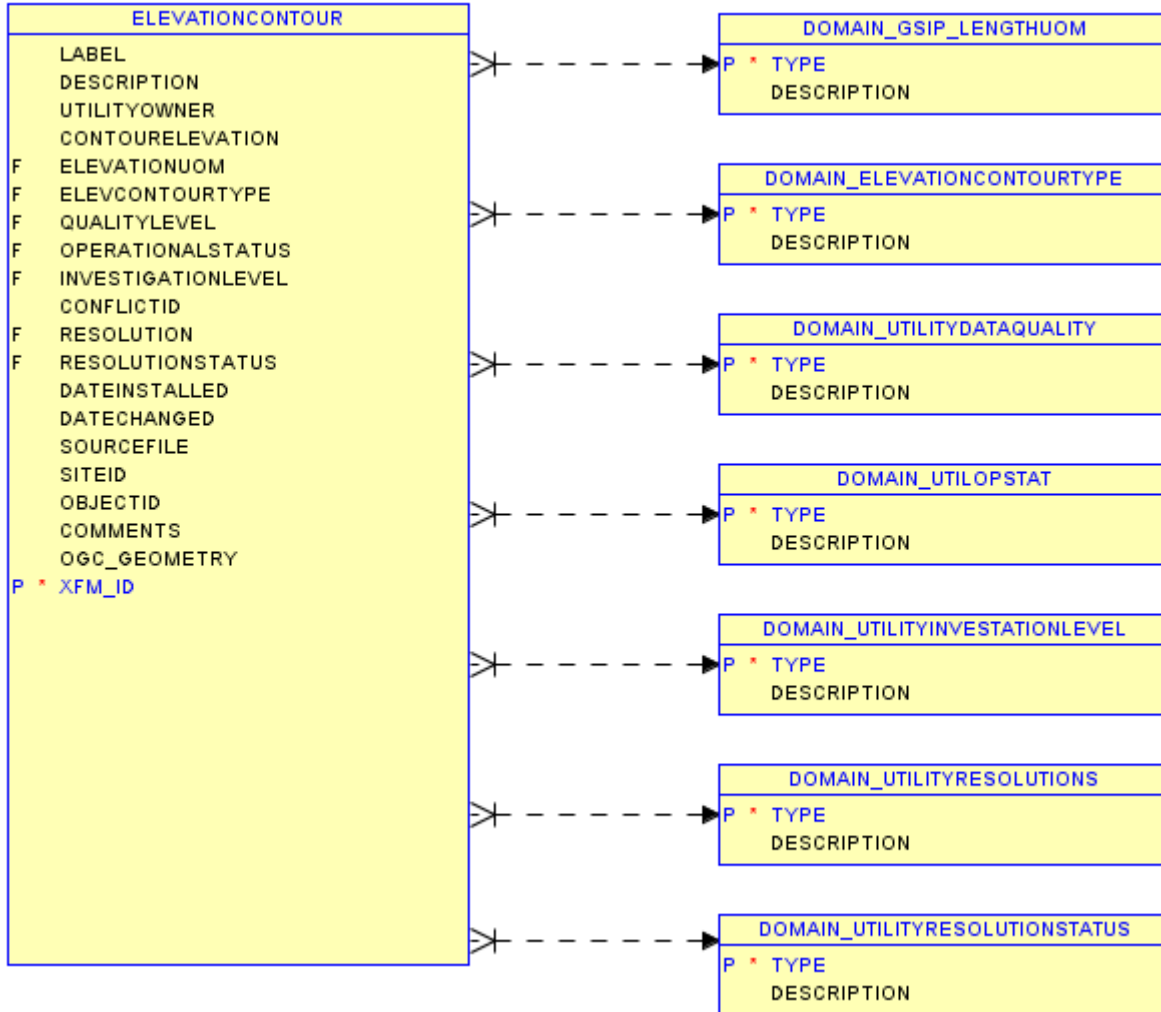

EXTERNALPROPERTYINTEREST

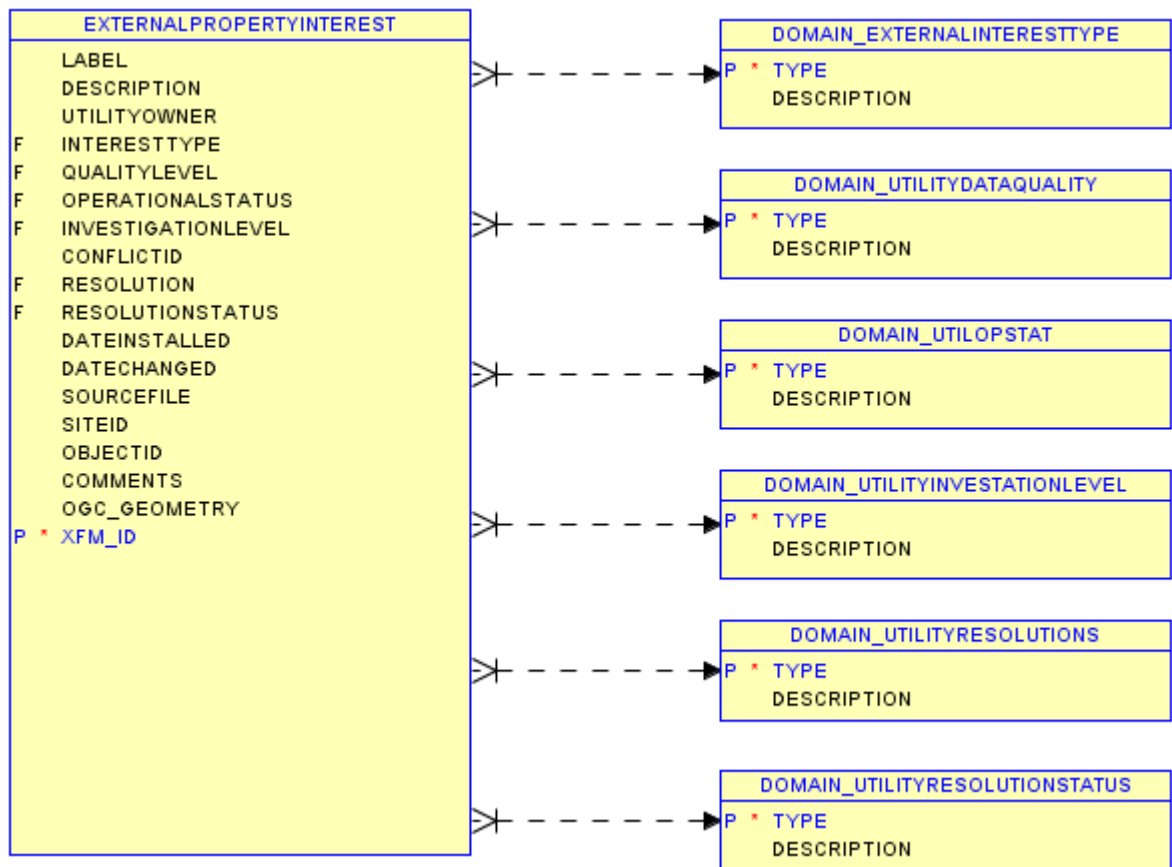

FENCE

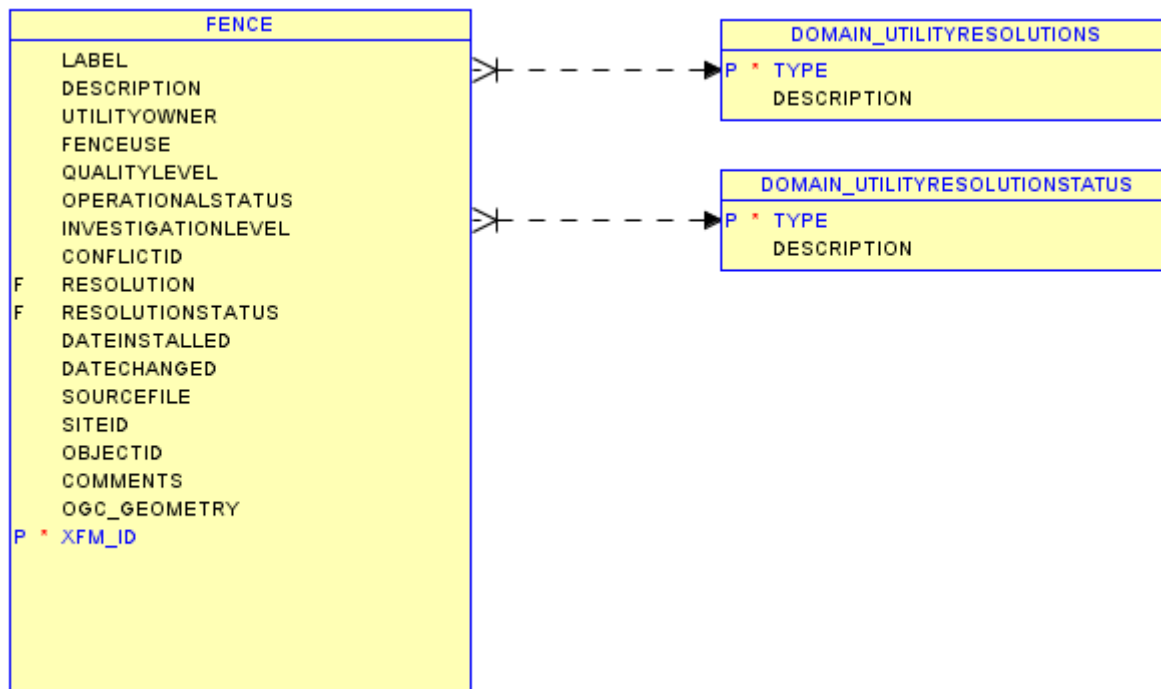

GASNODE

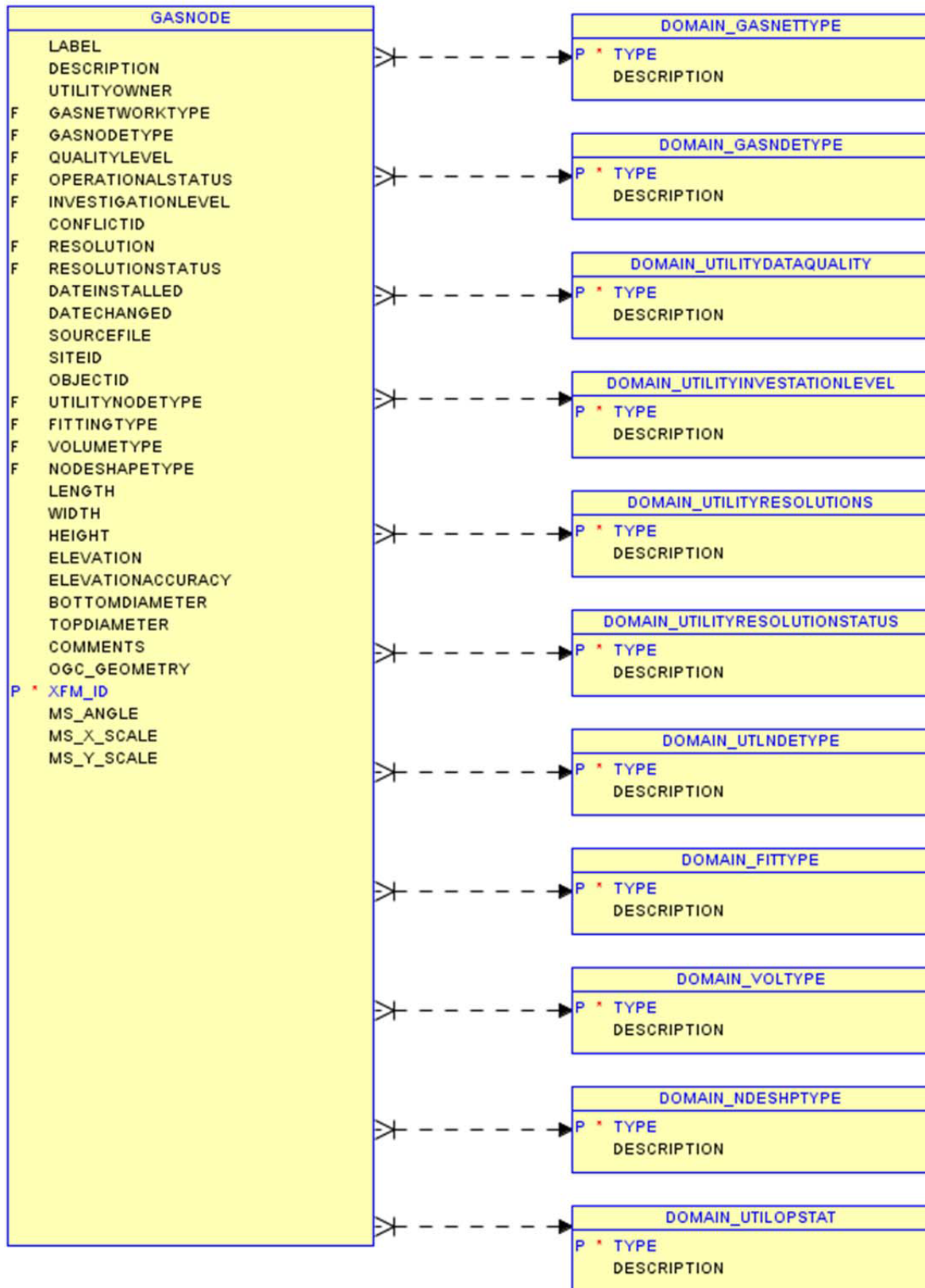

GASSEGMENT

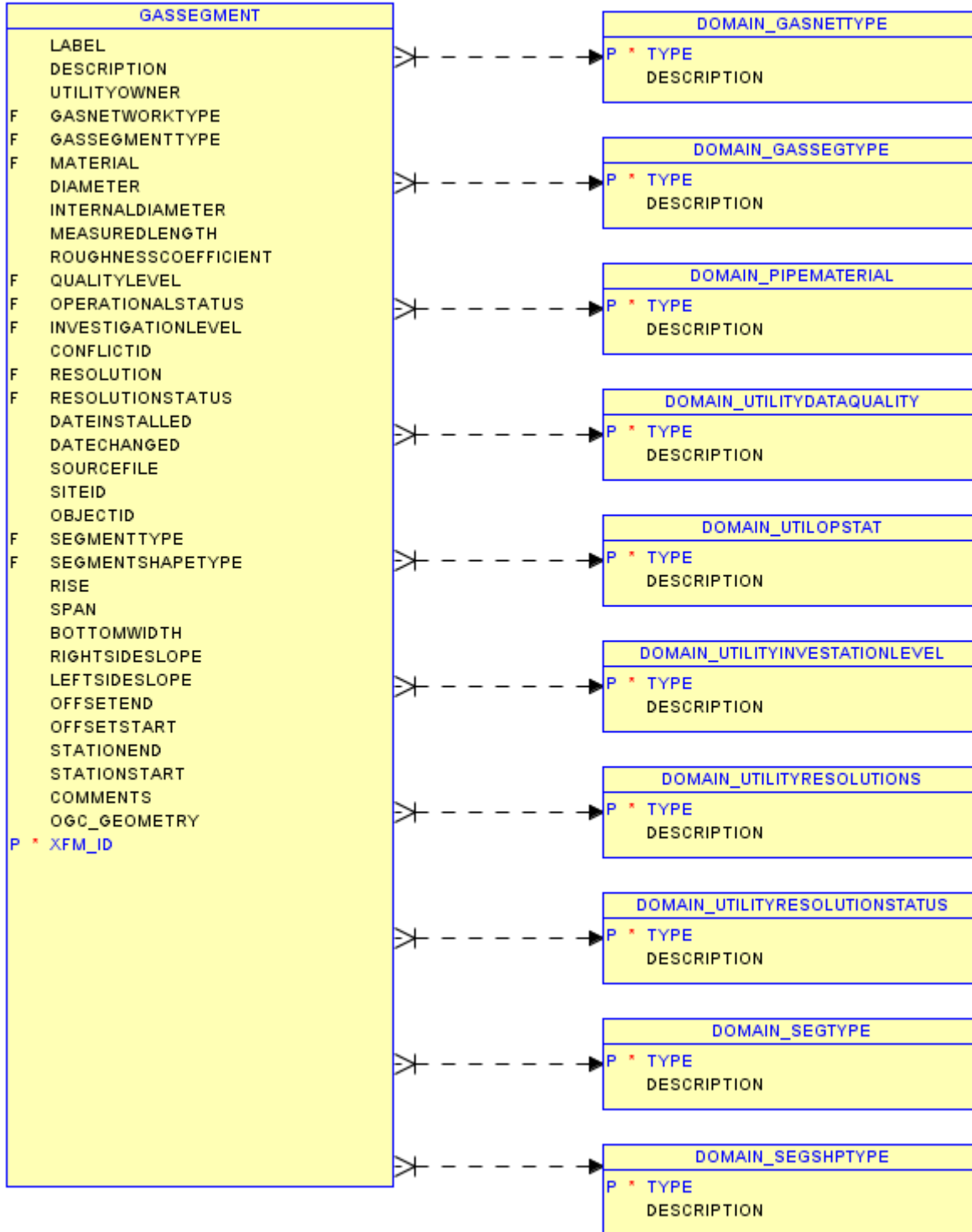

GRID

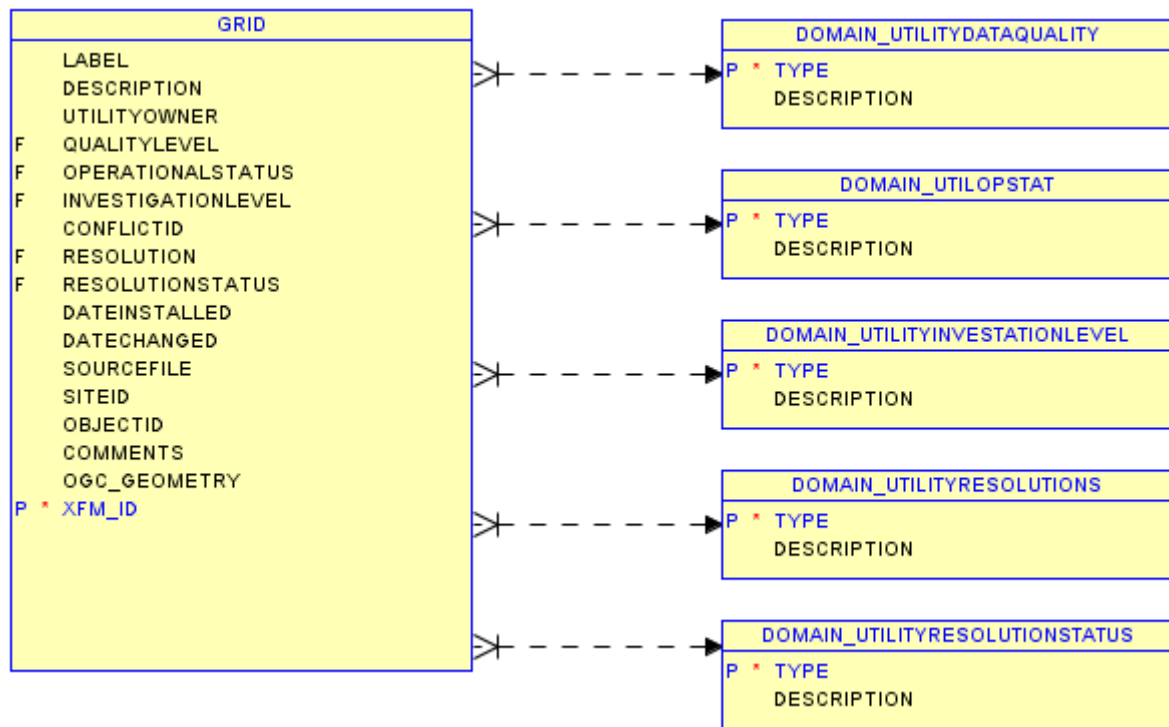

GUARDRAIL

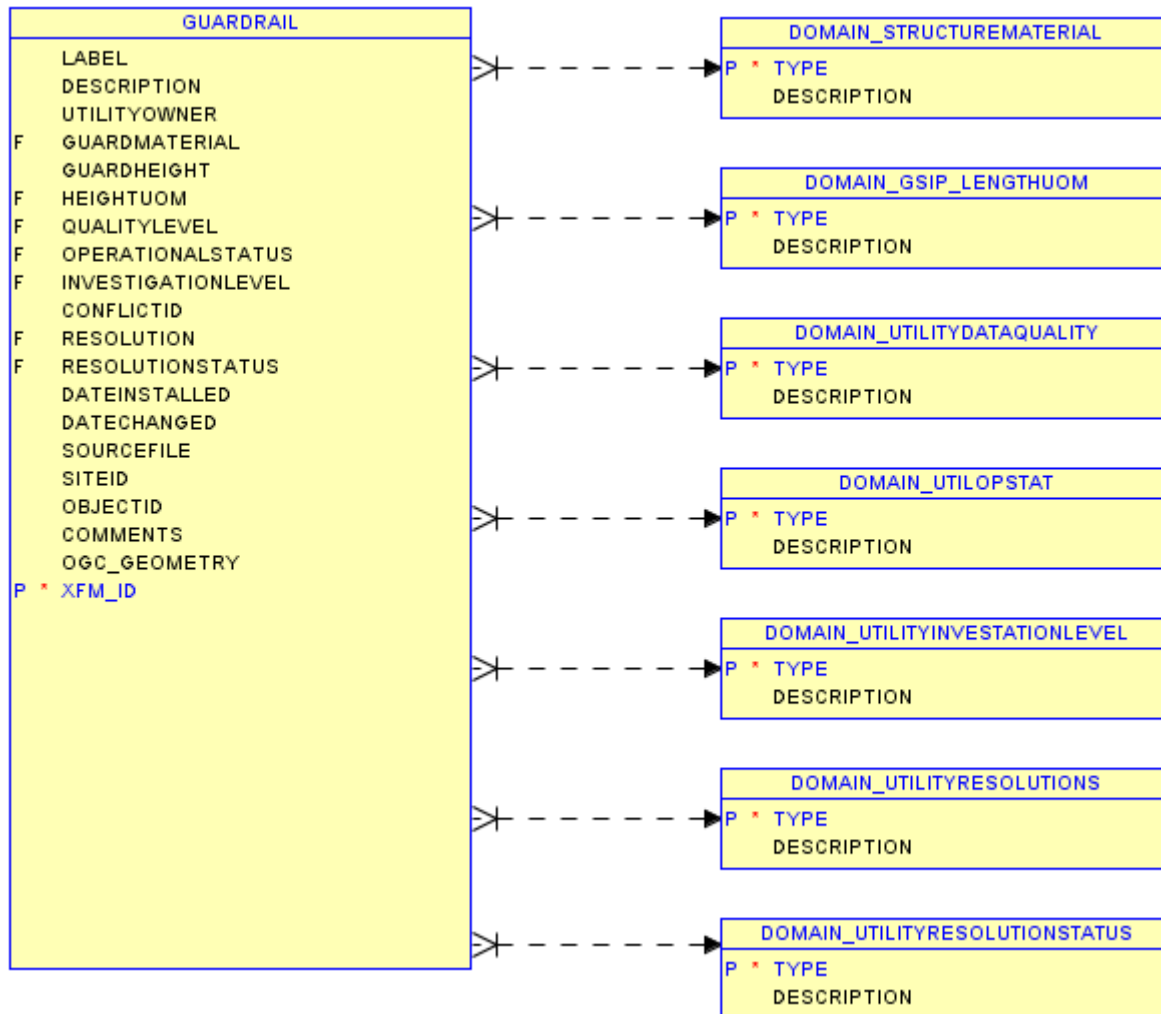

INSTALLATION

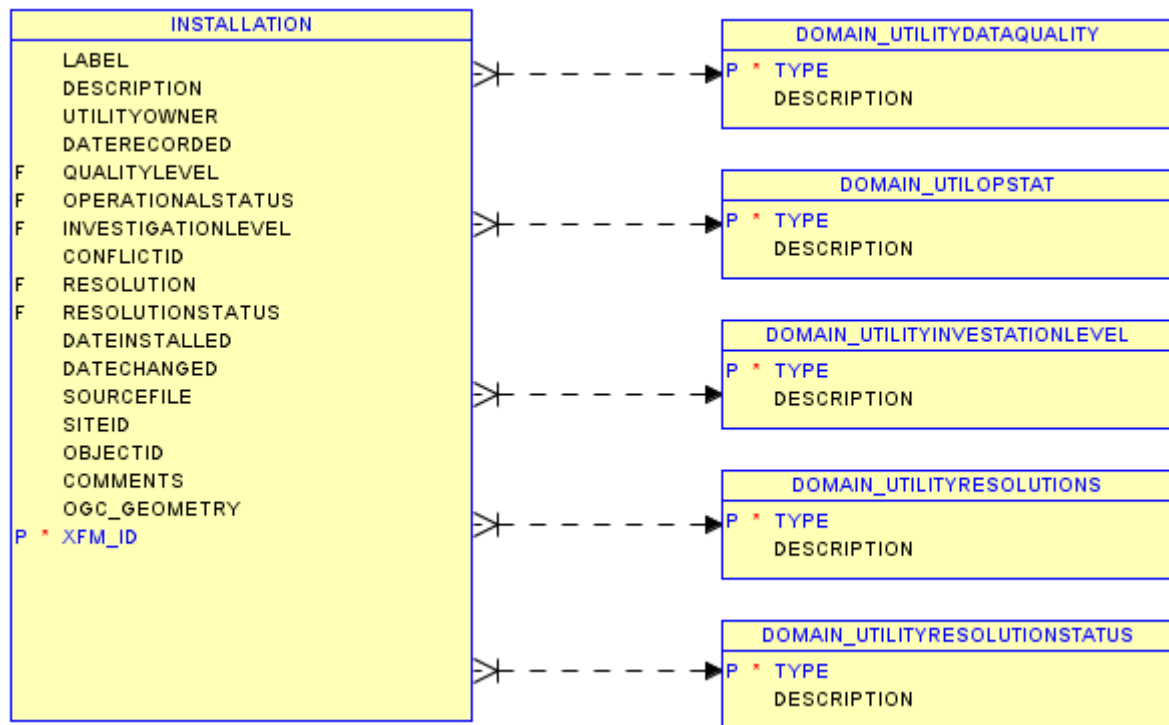

LANDPARCEL

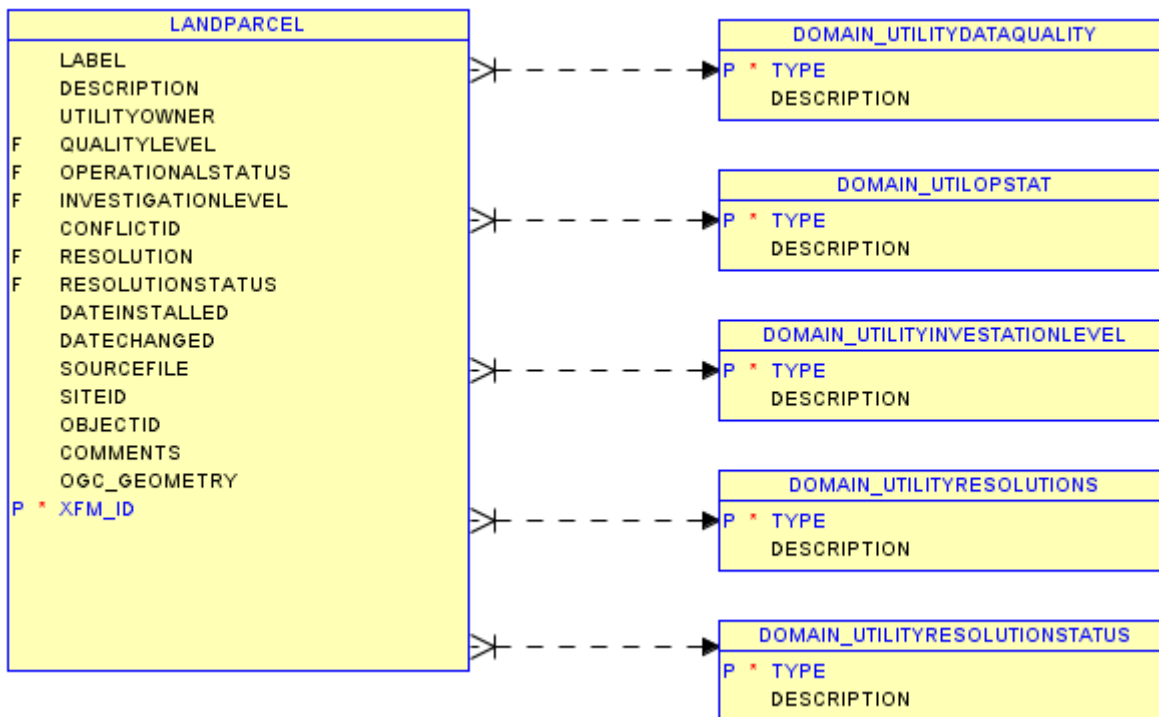

PAVEMENTSECTION

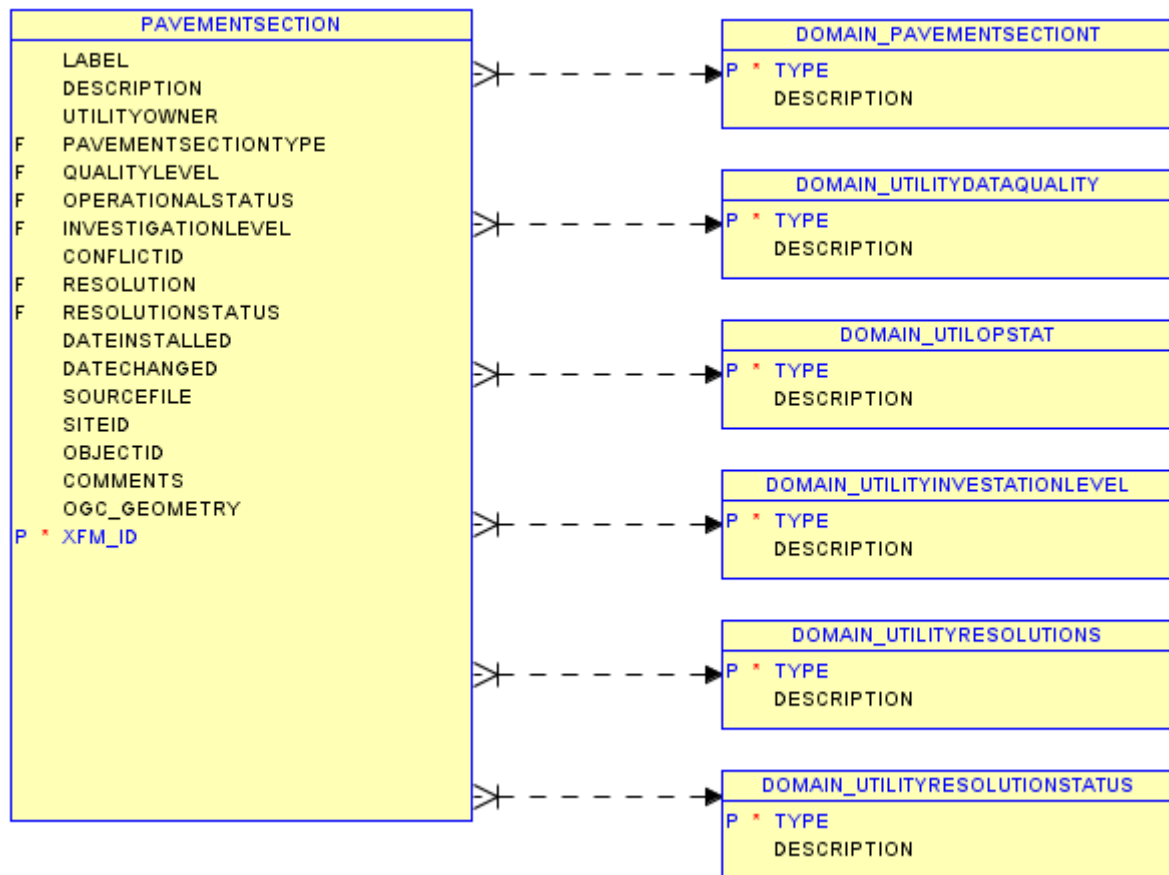

POLNODE

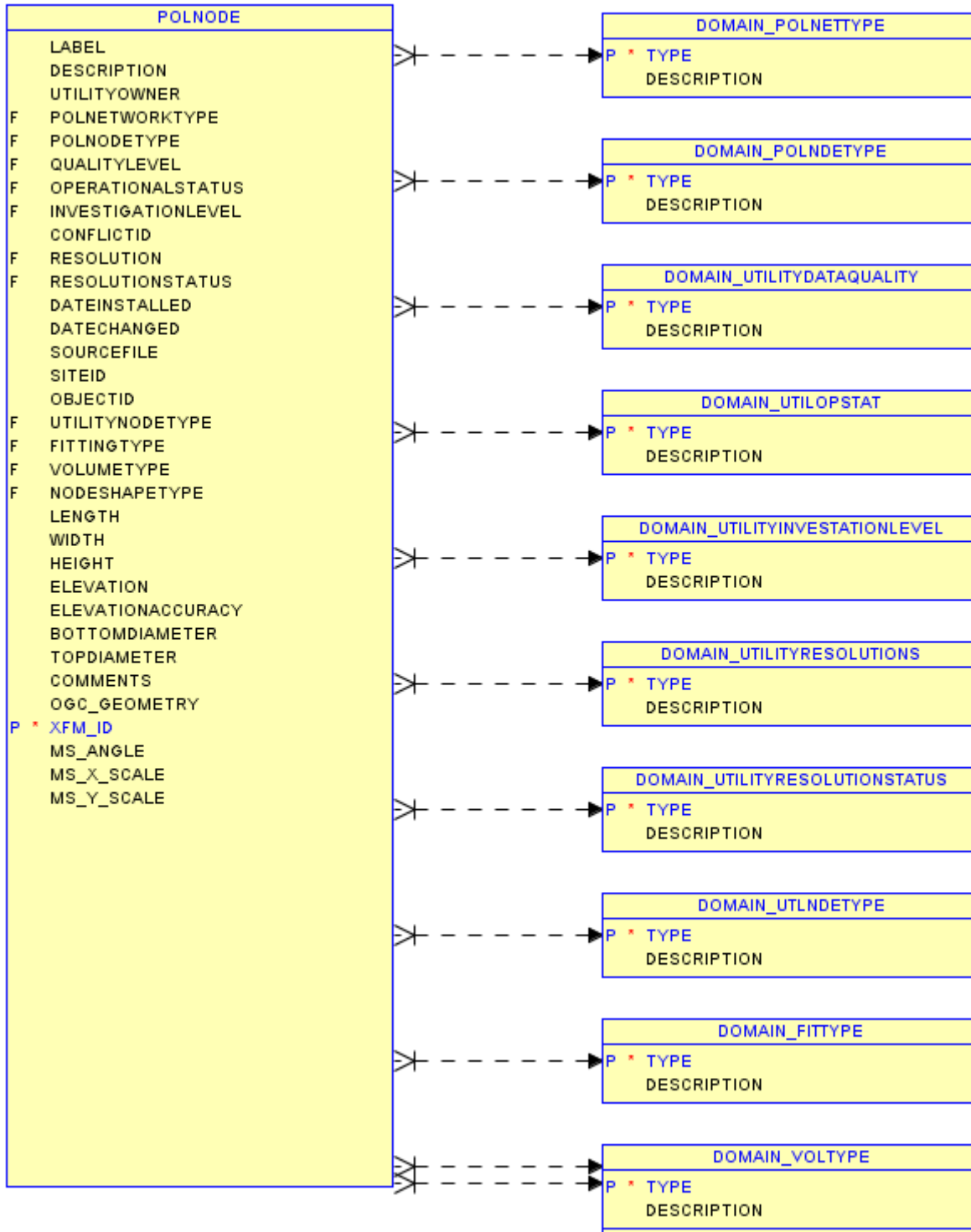

POLSEGMENT

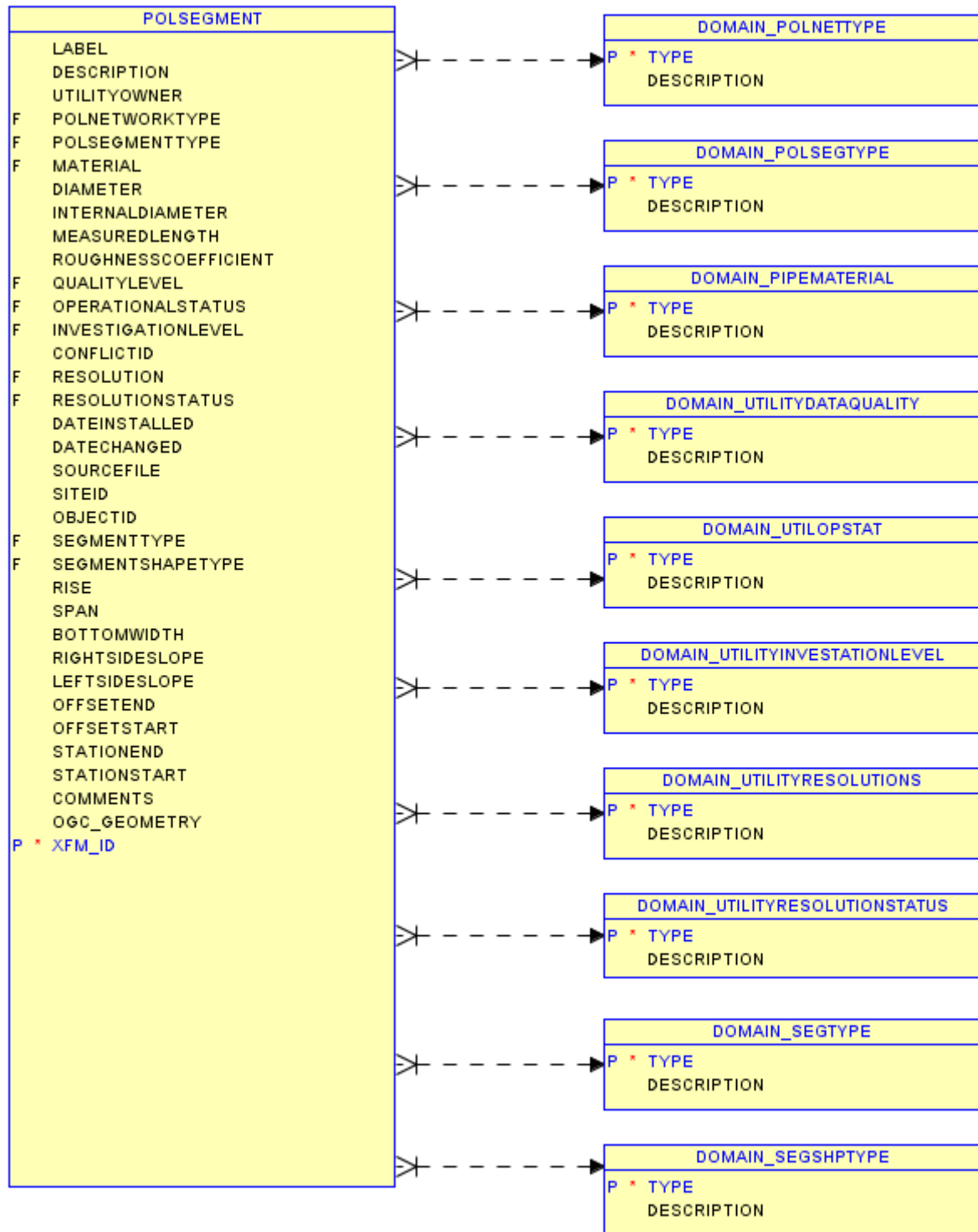

PROJECTREFERENCE

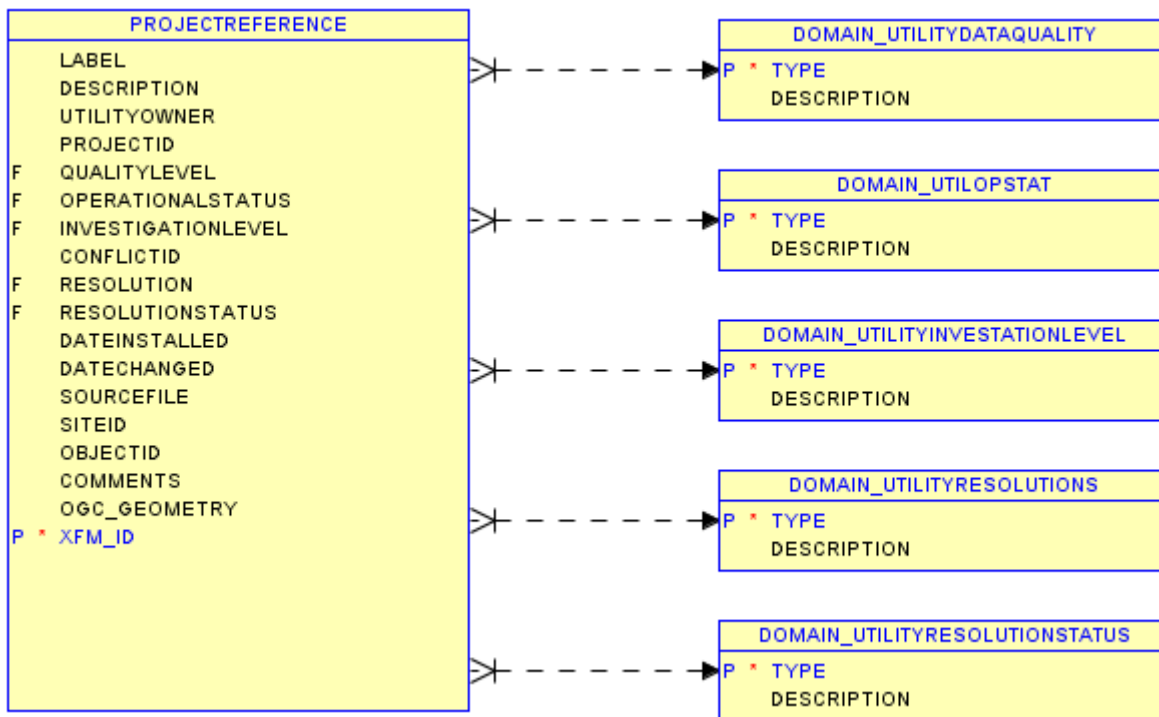

RAILTRACK

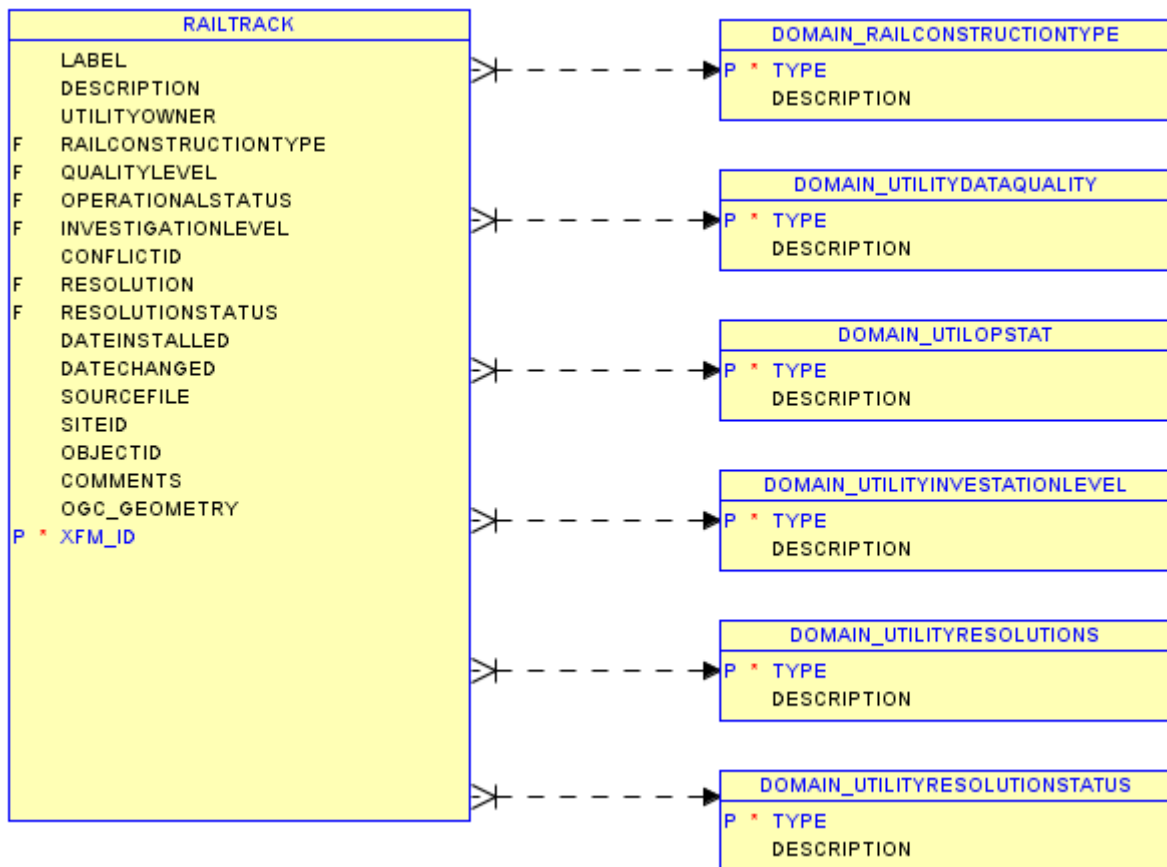

RECREATIONAREA

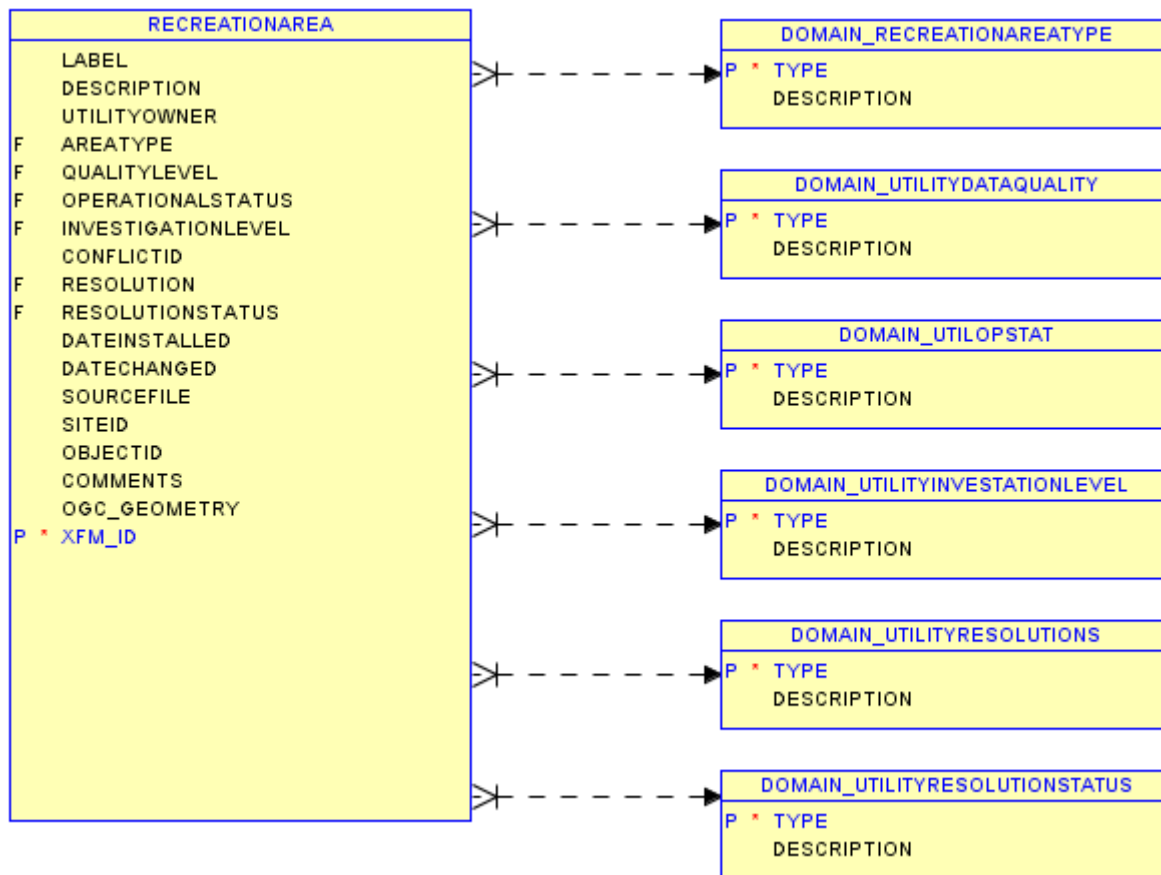

RECREATIONFEATURE

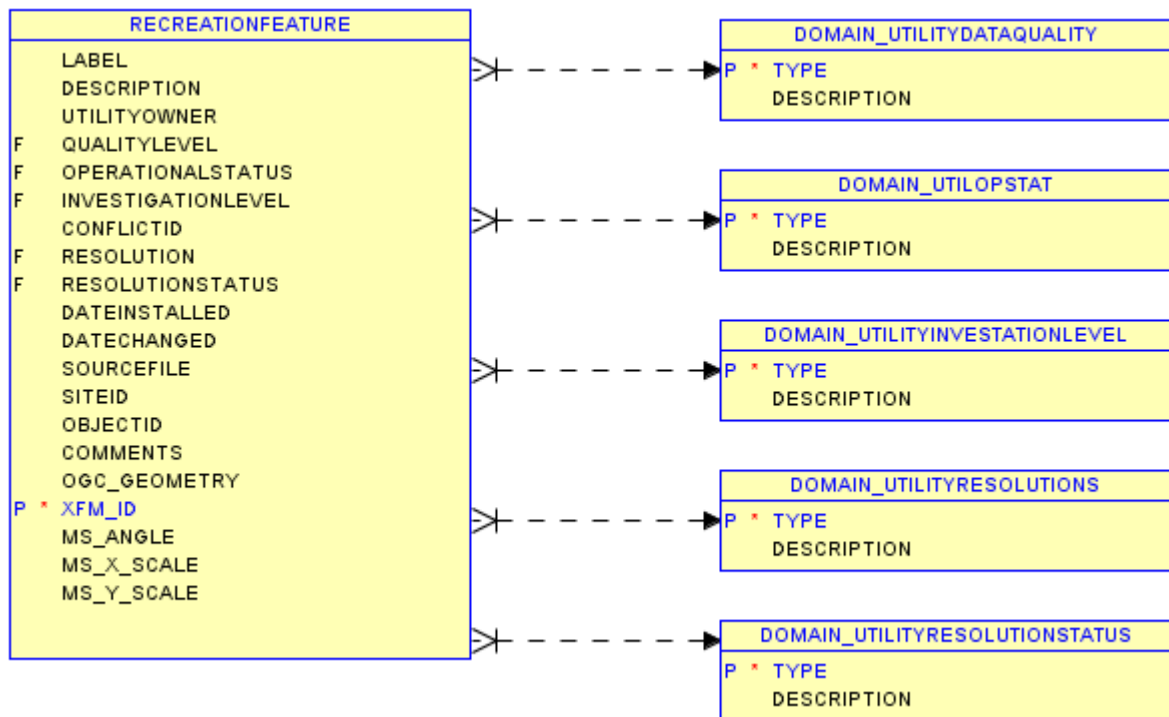

RESTRICTEDAREA

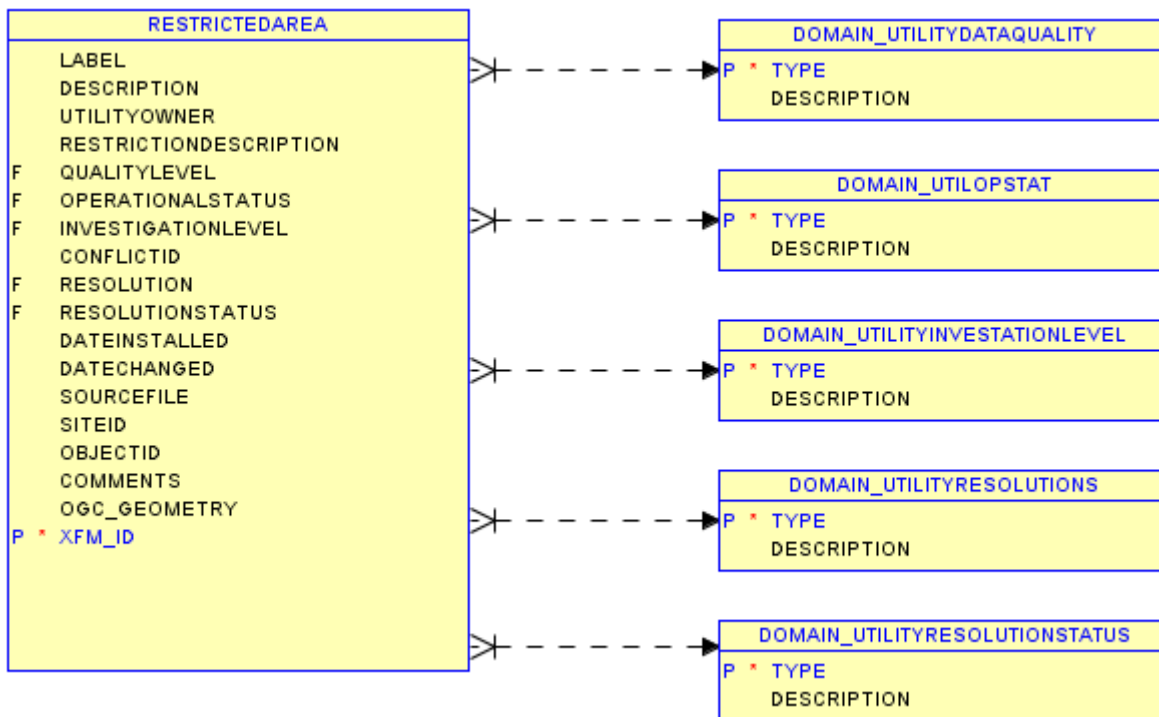

ROADPATH

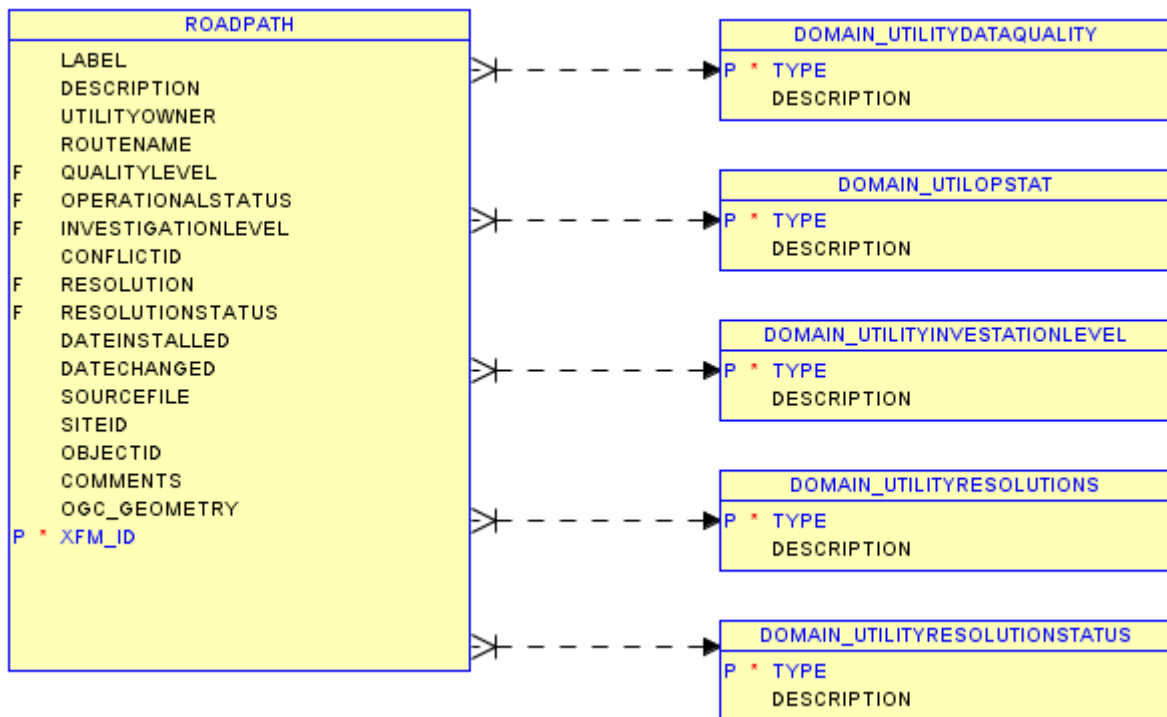

SIGN

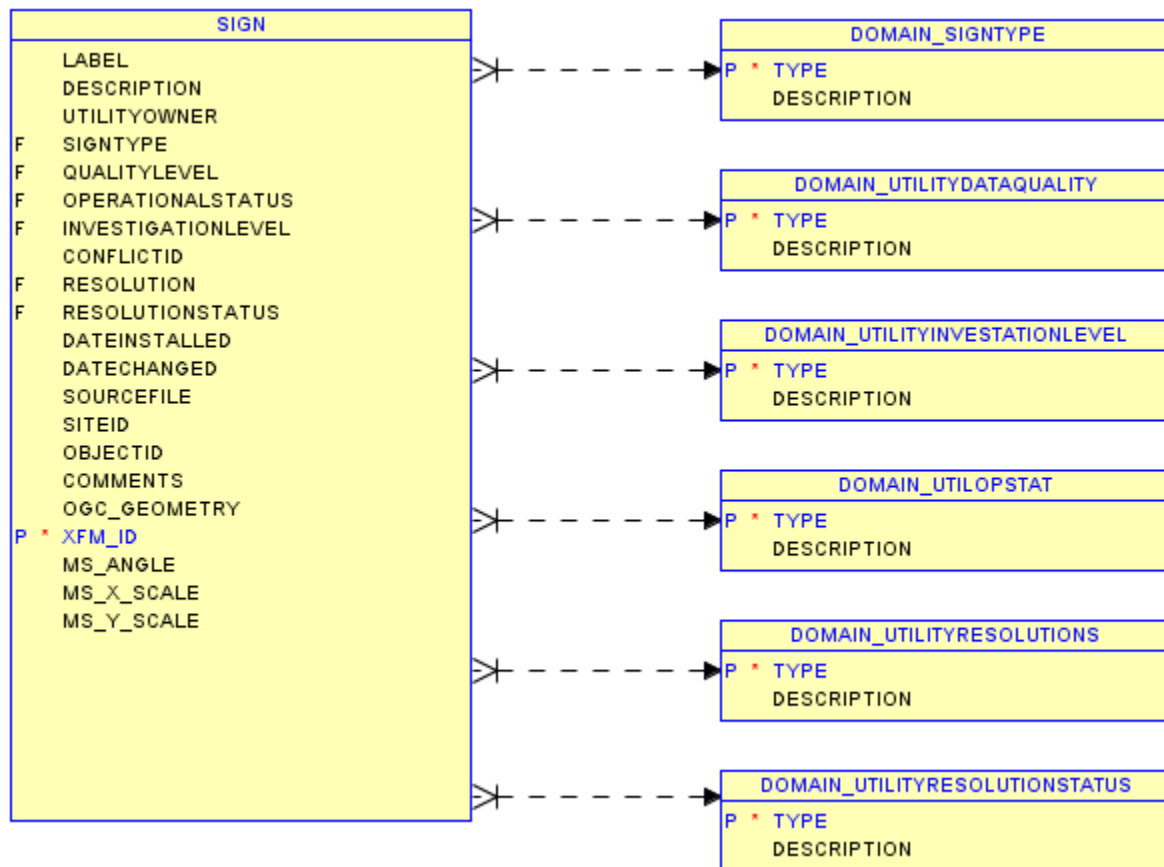

SITE

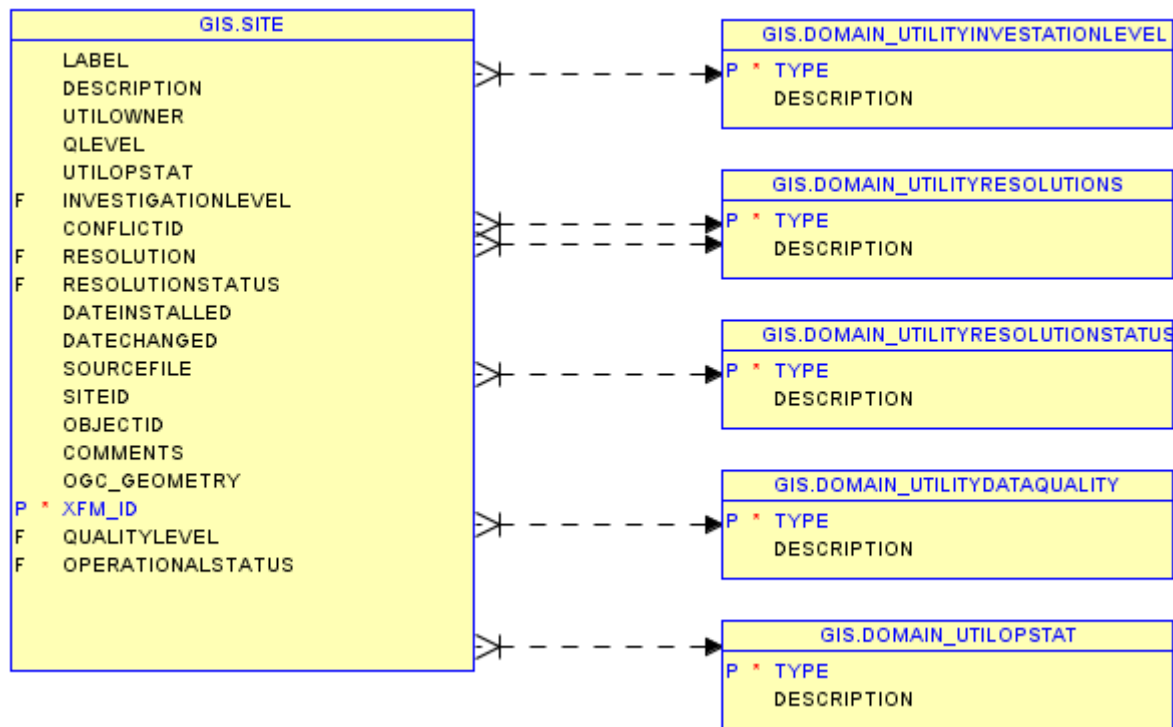

STRUCTURE

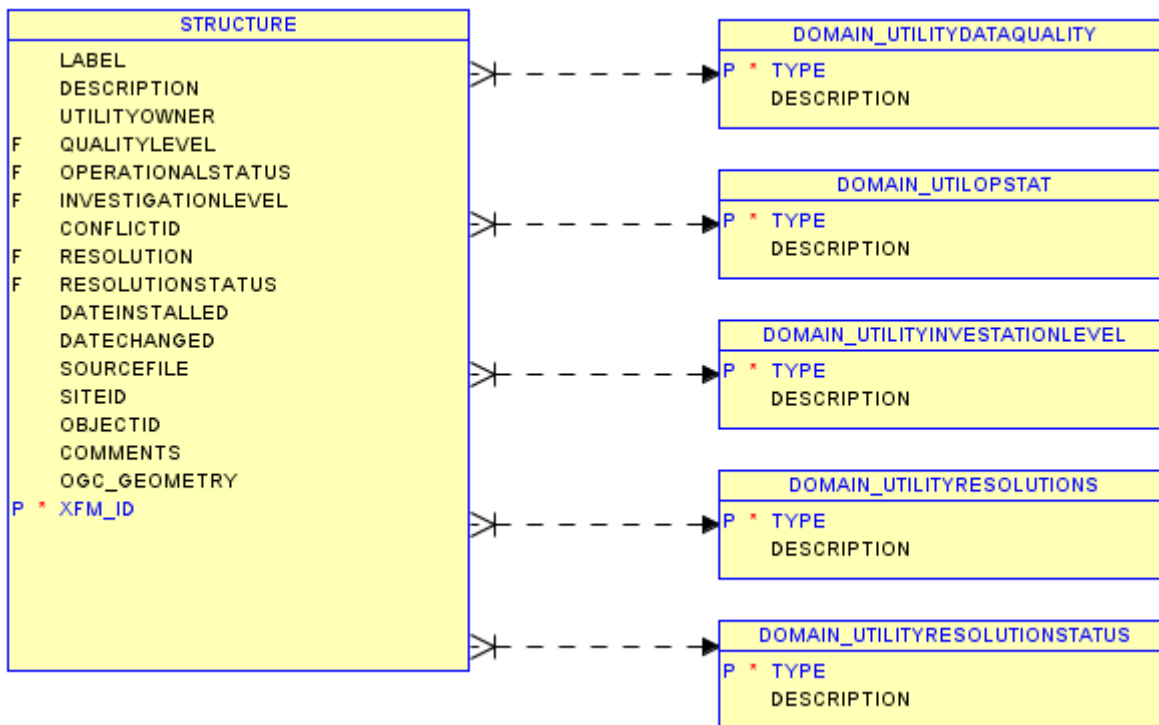

SURVEYJOB

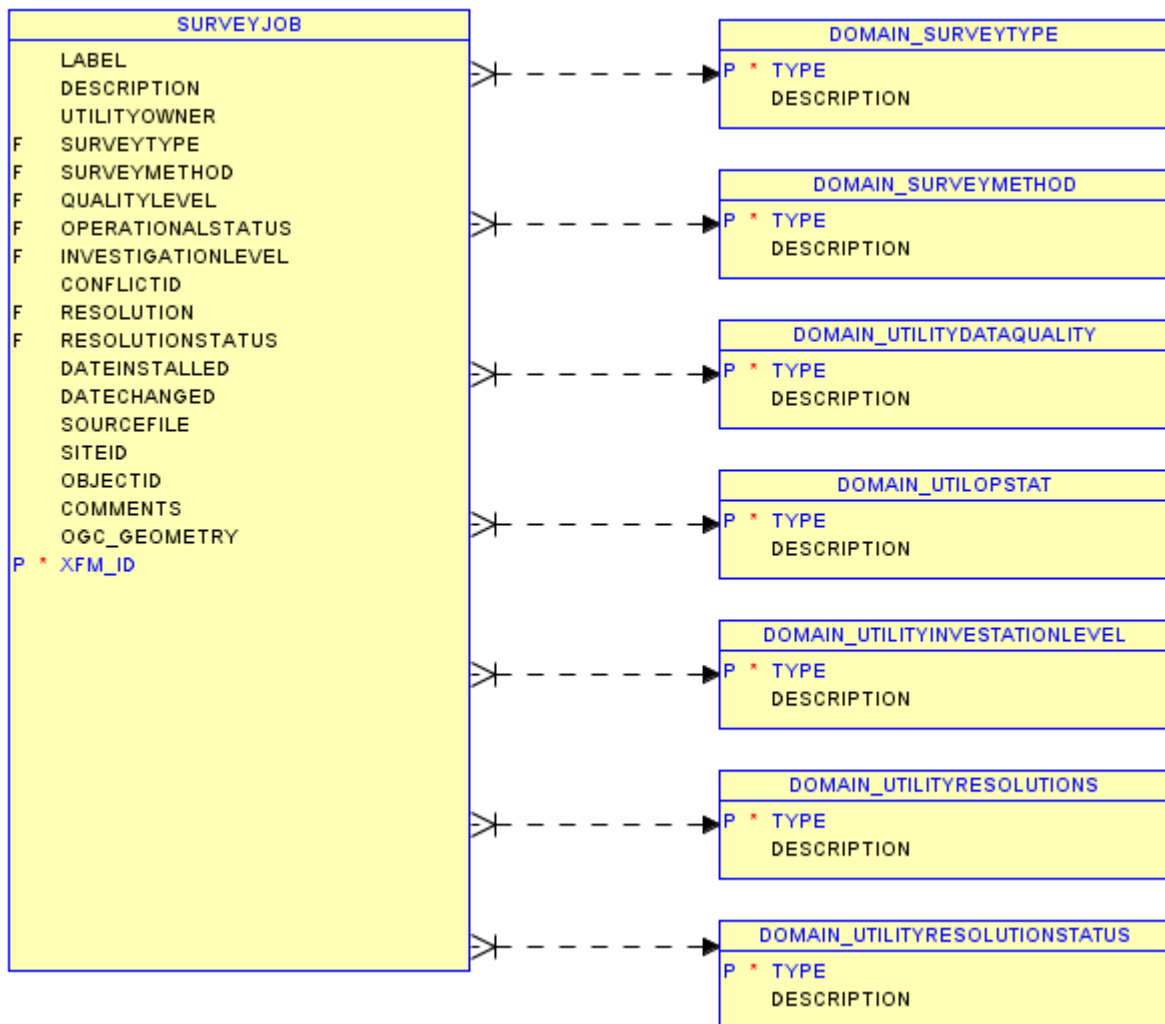

SURVEYPOINT

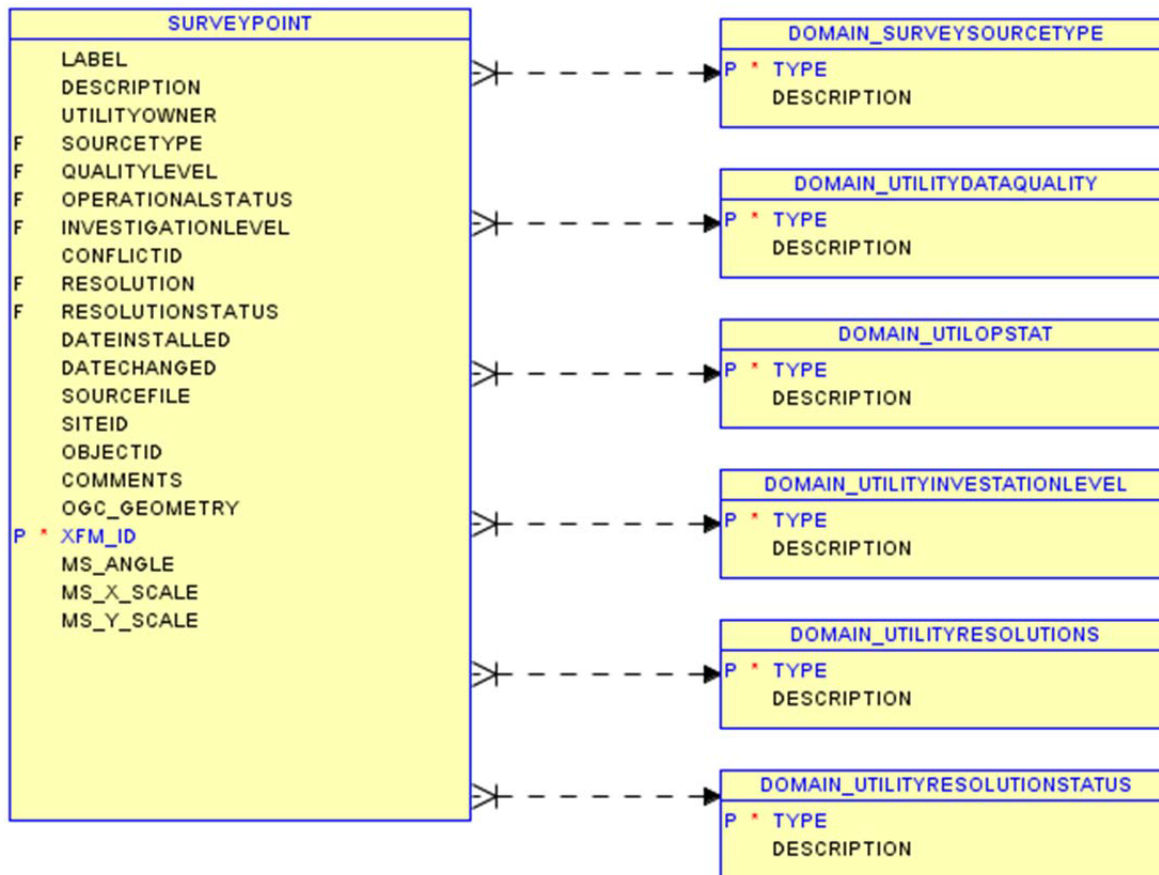

THERMALNODE

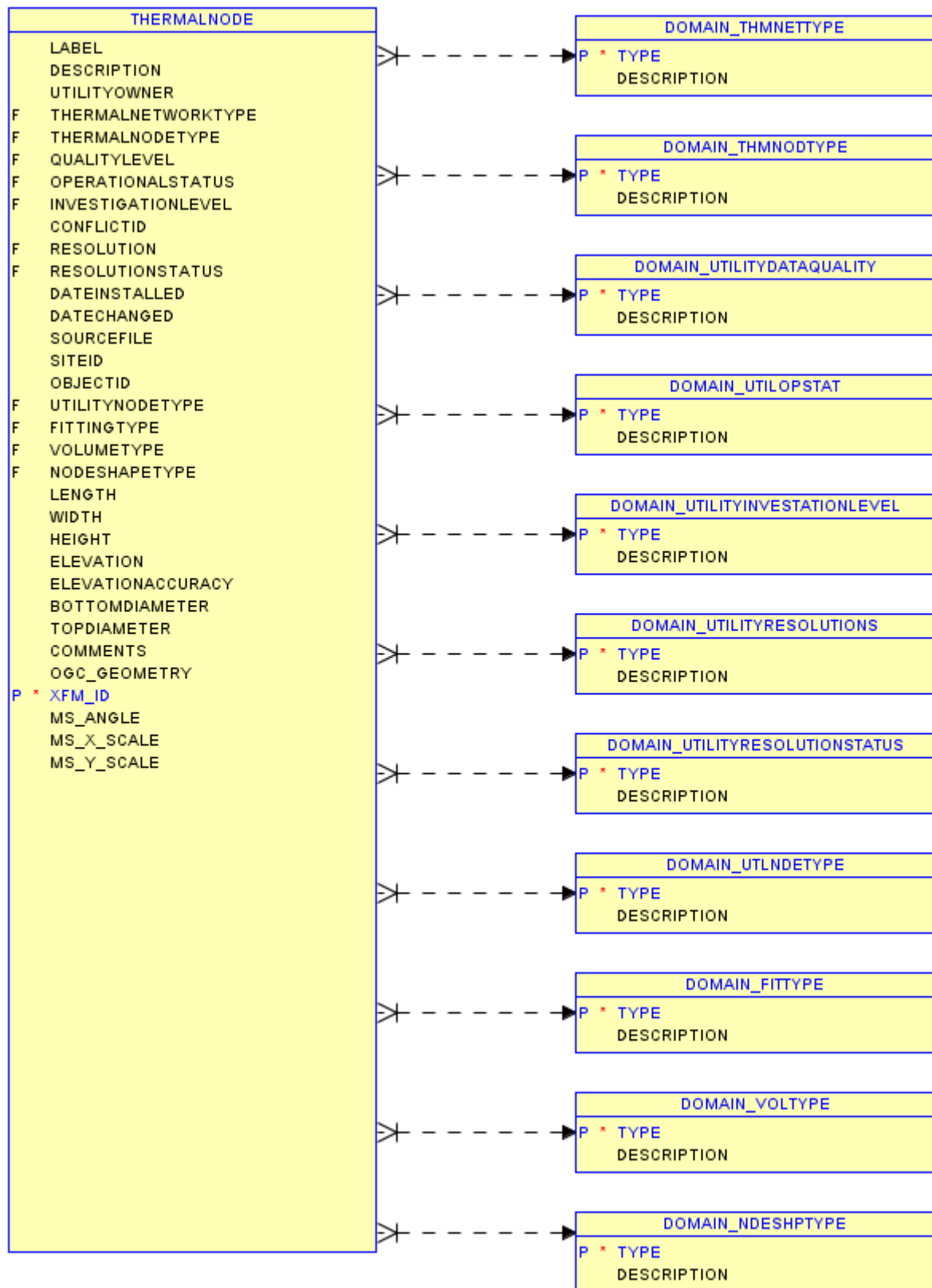

THERMALSEGMENT

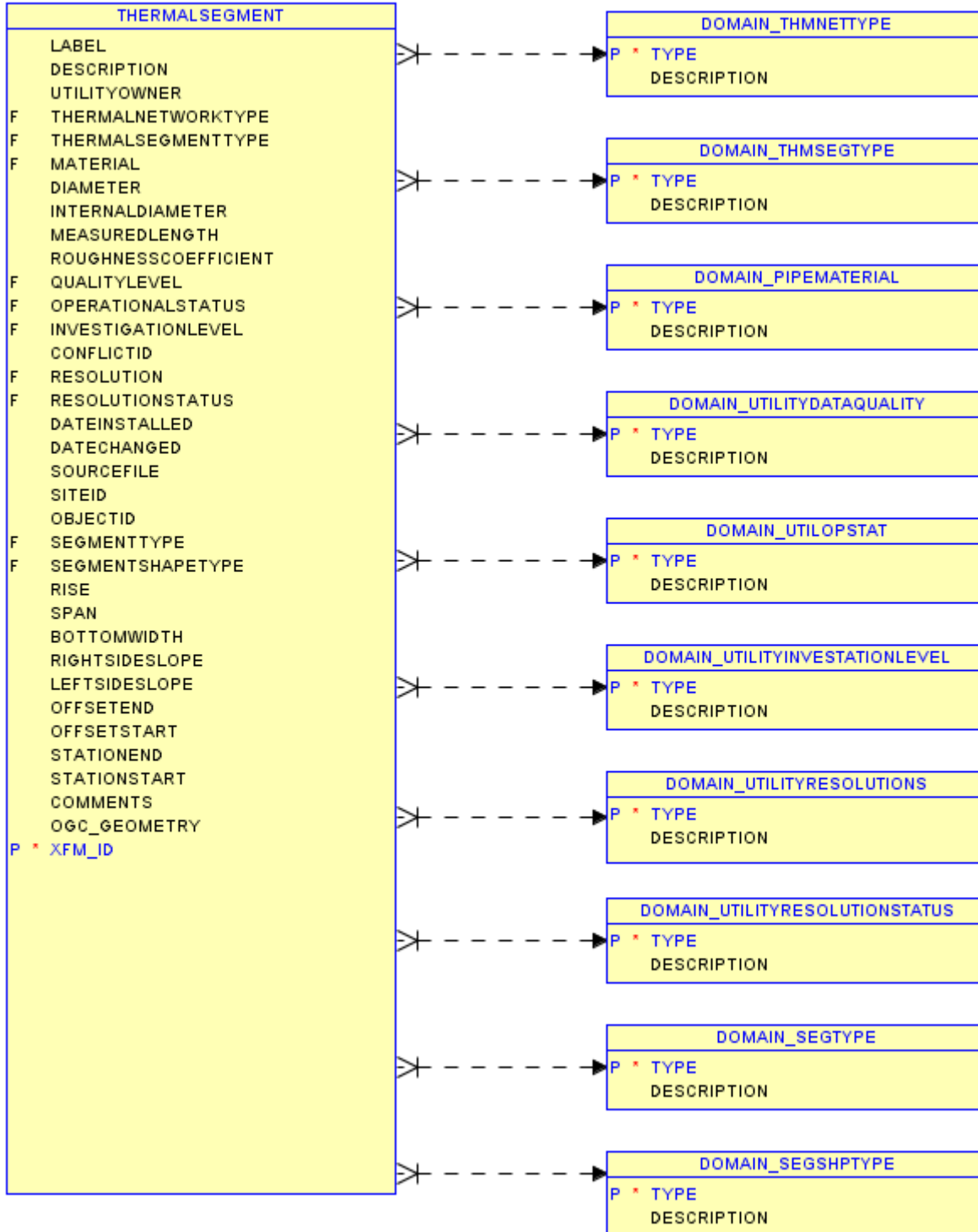

TOWER

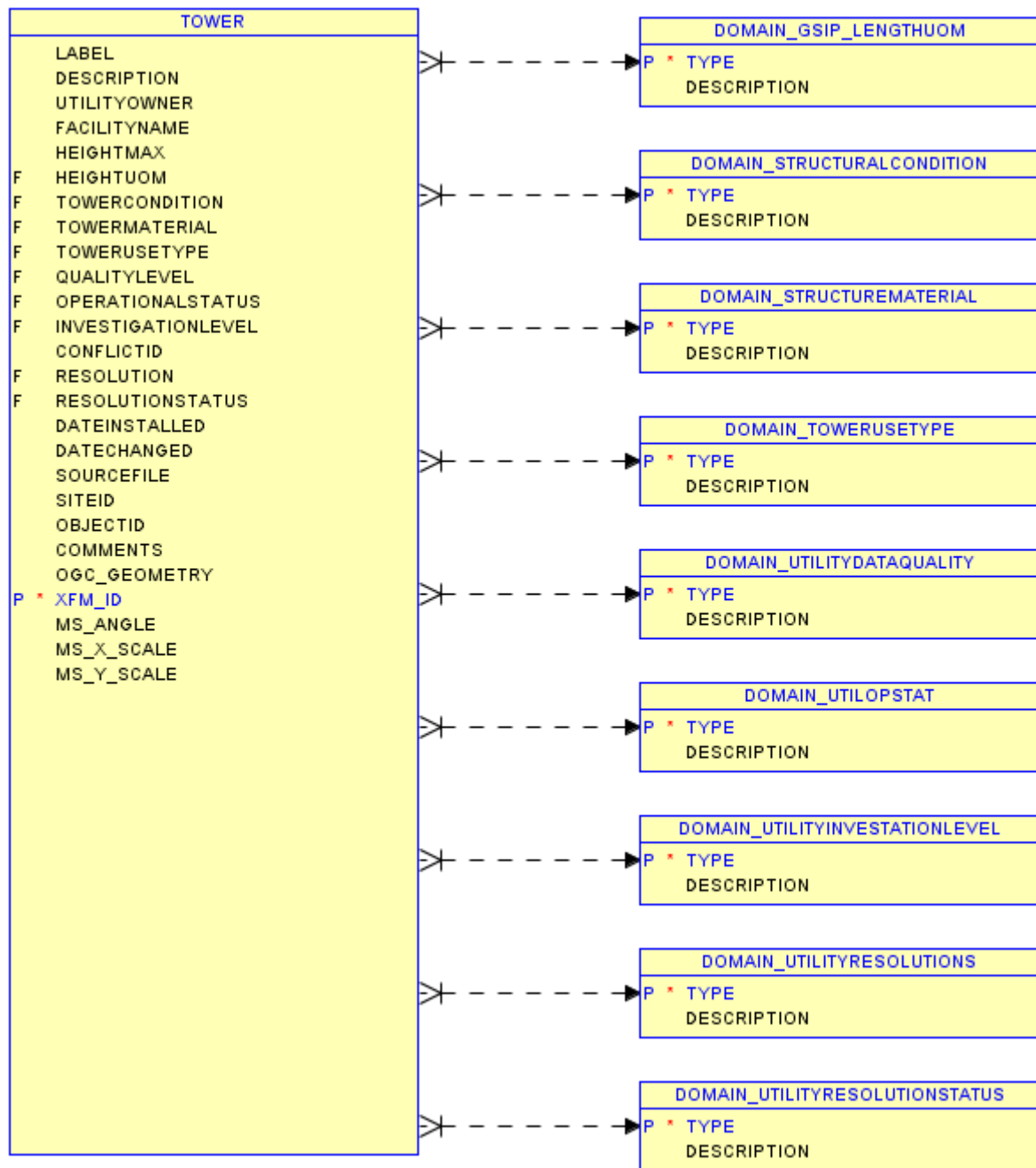

TRANSPORTATIONTUNNEL

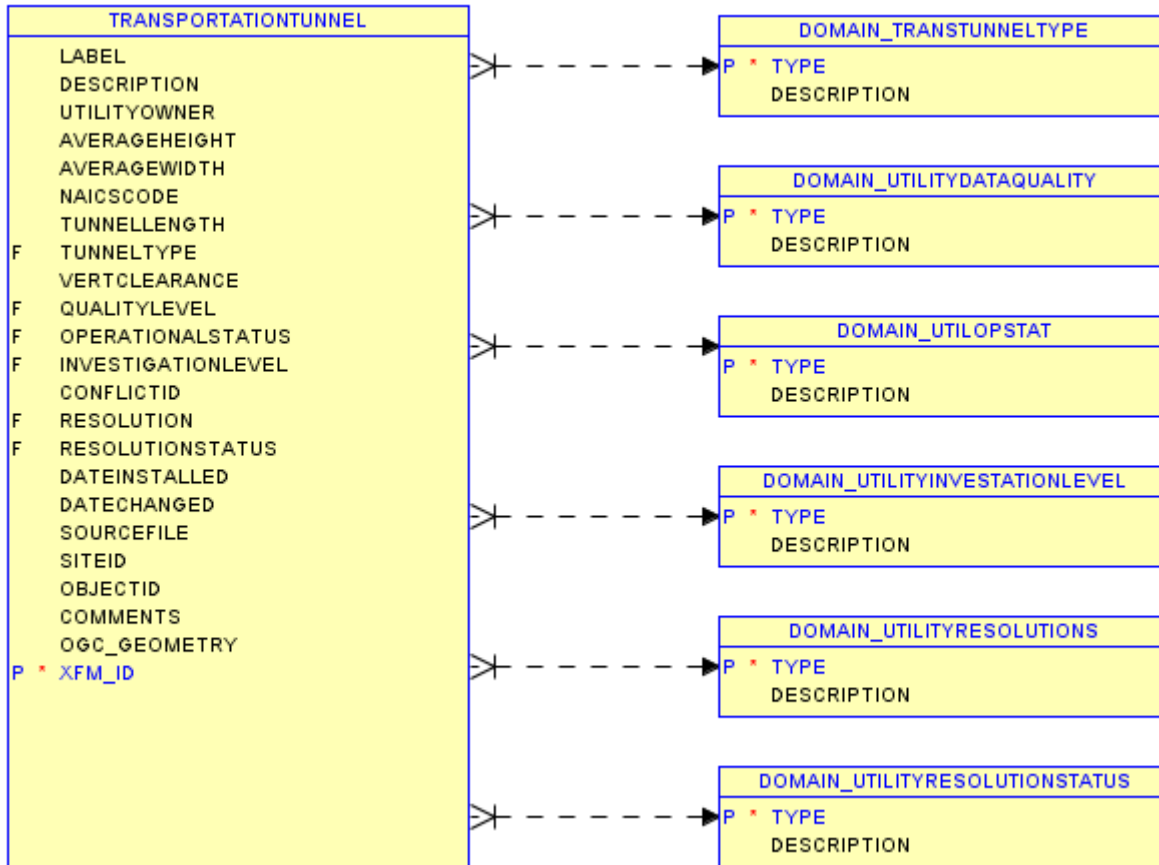

UTILITYFEATURE

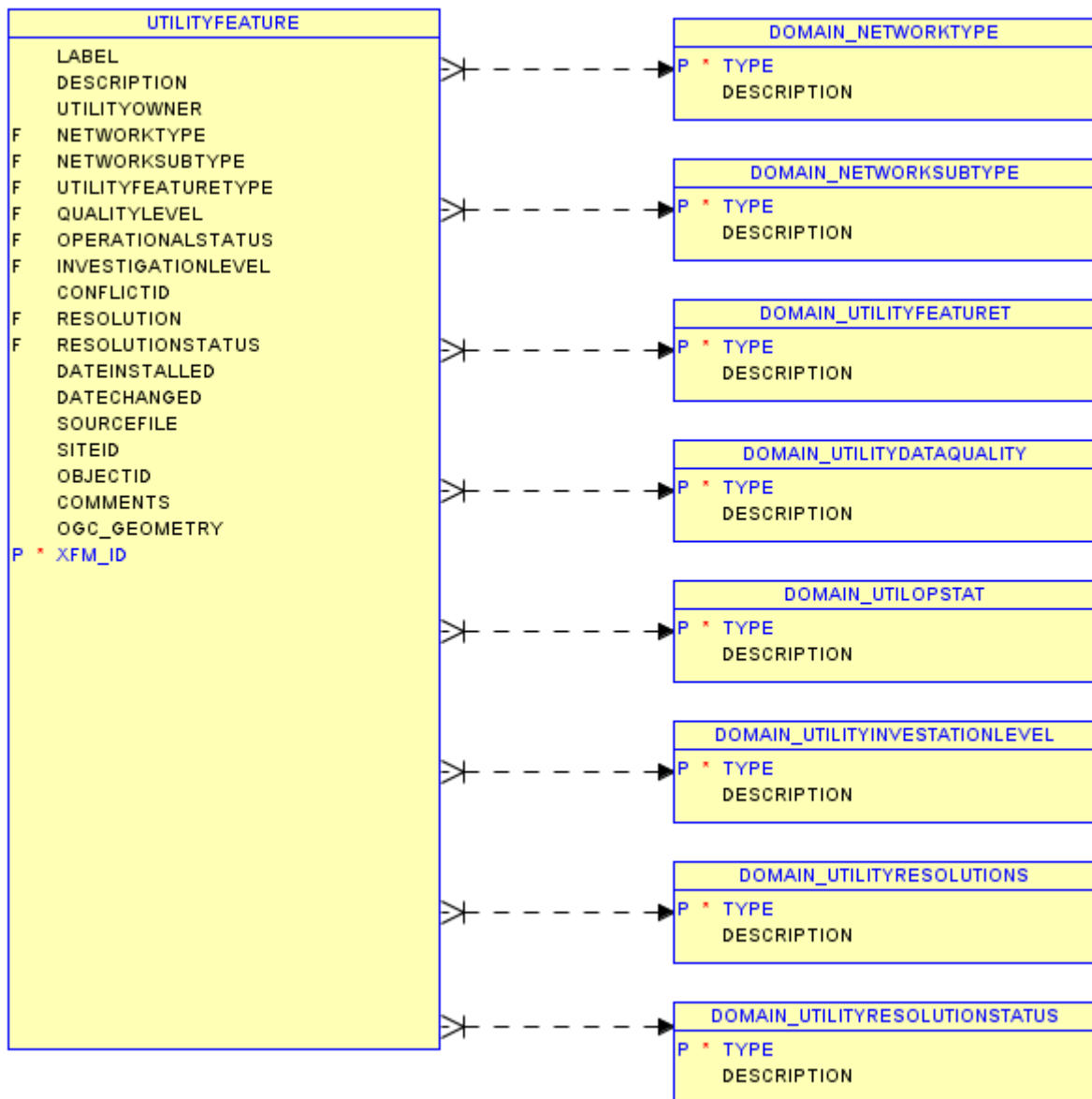

WALL

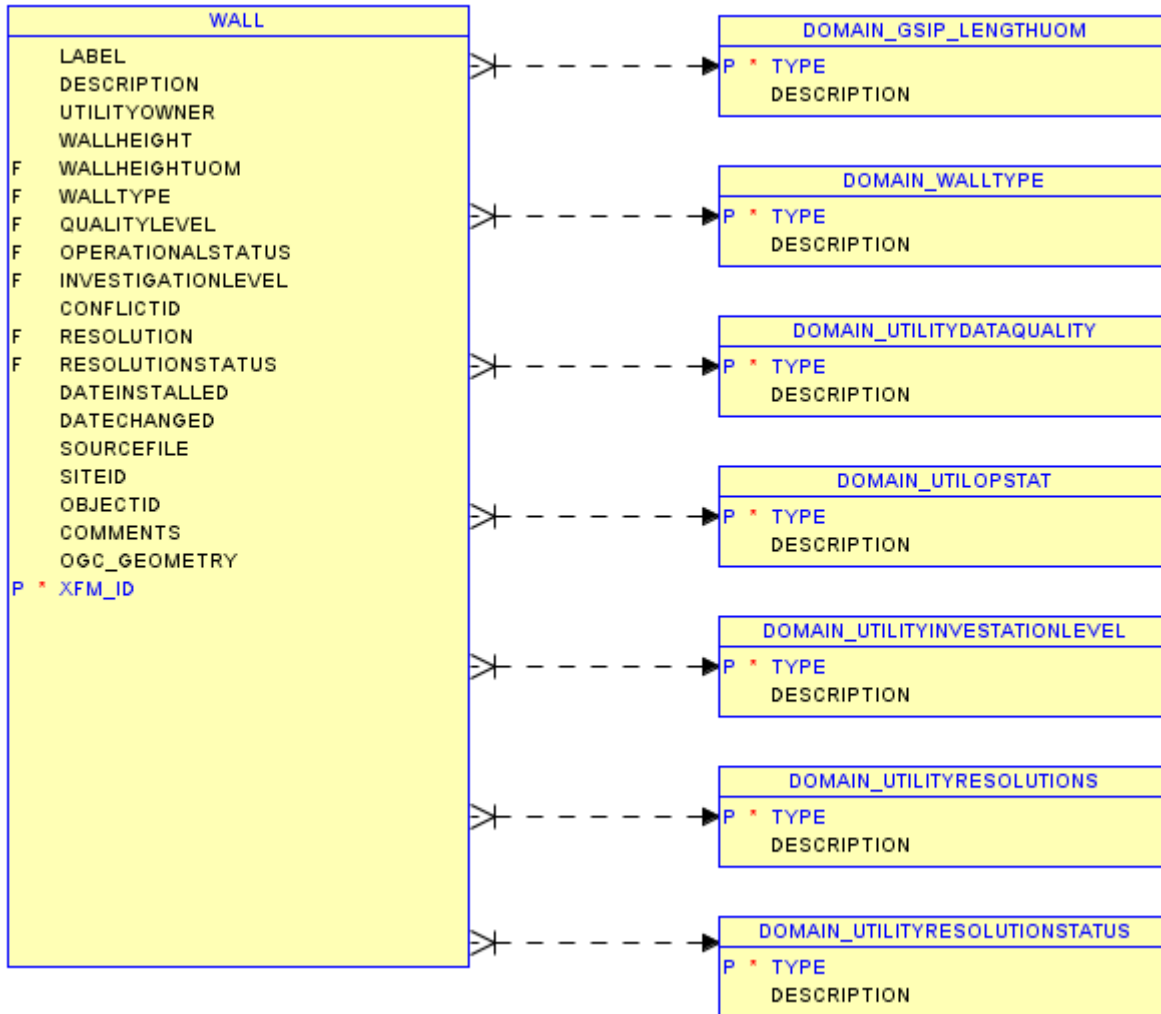

WASTEWATERNODE

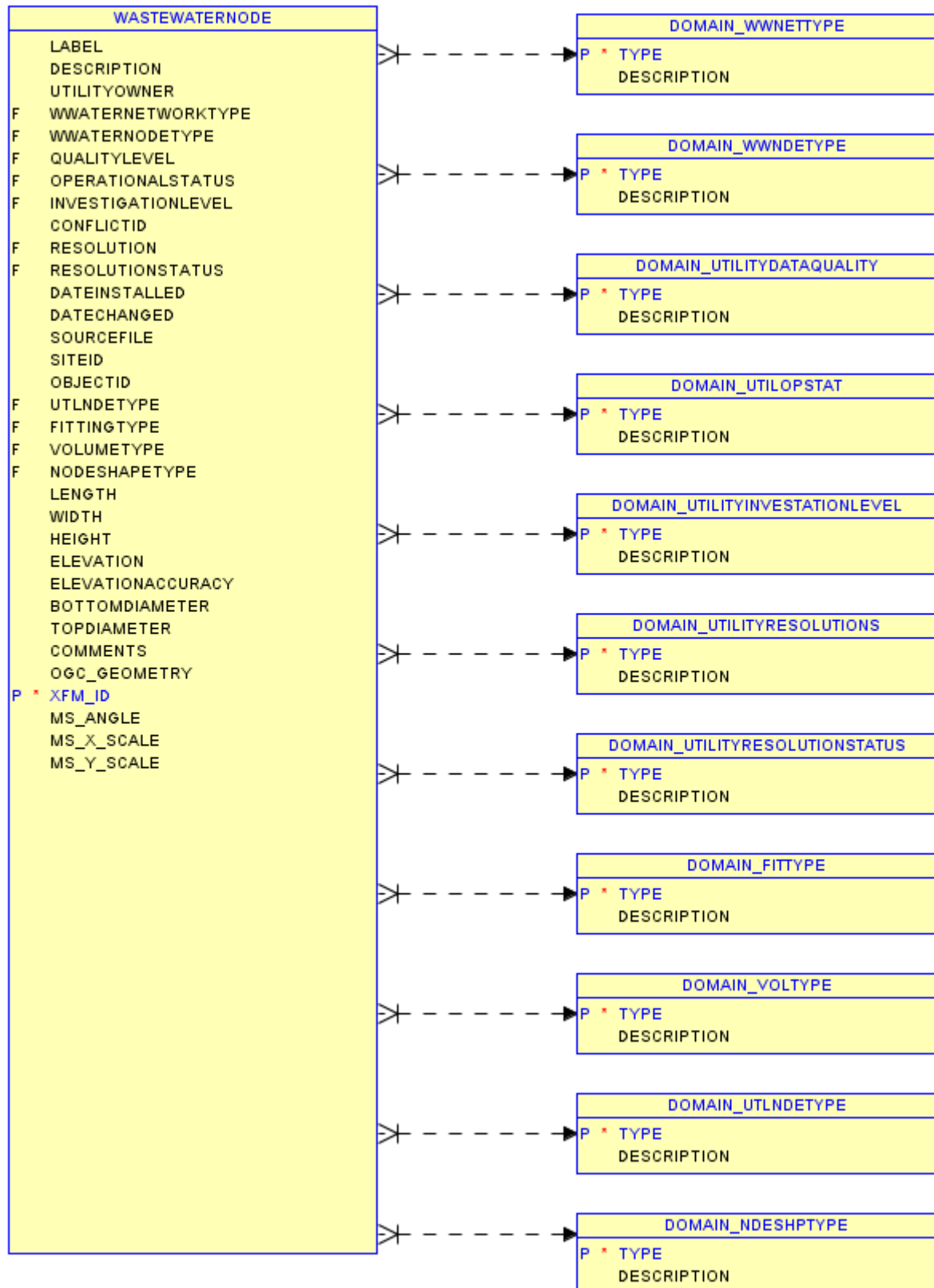

WASTEWATERSEGMENT

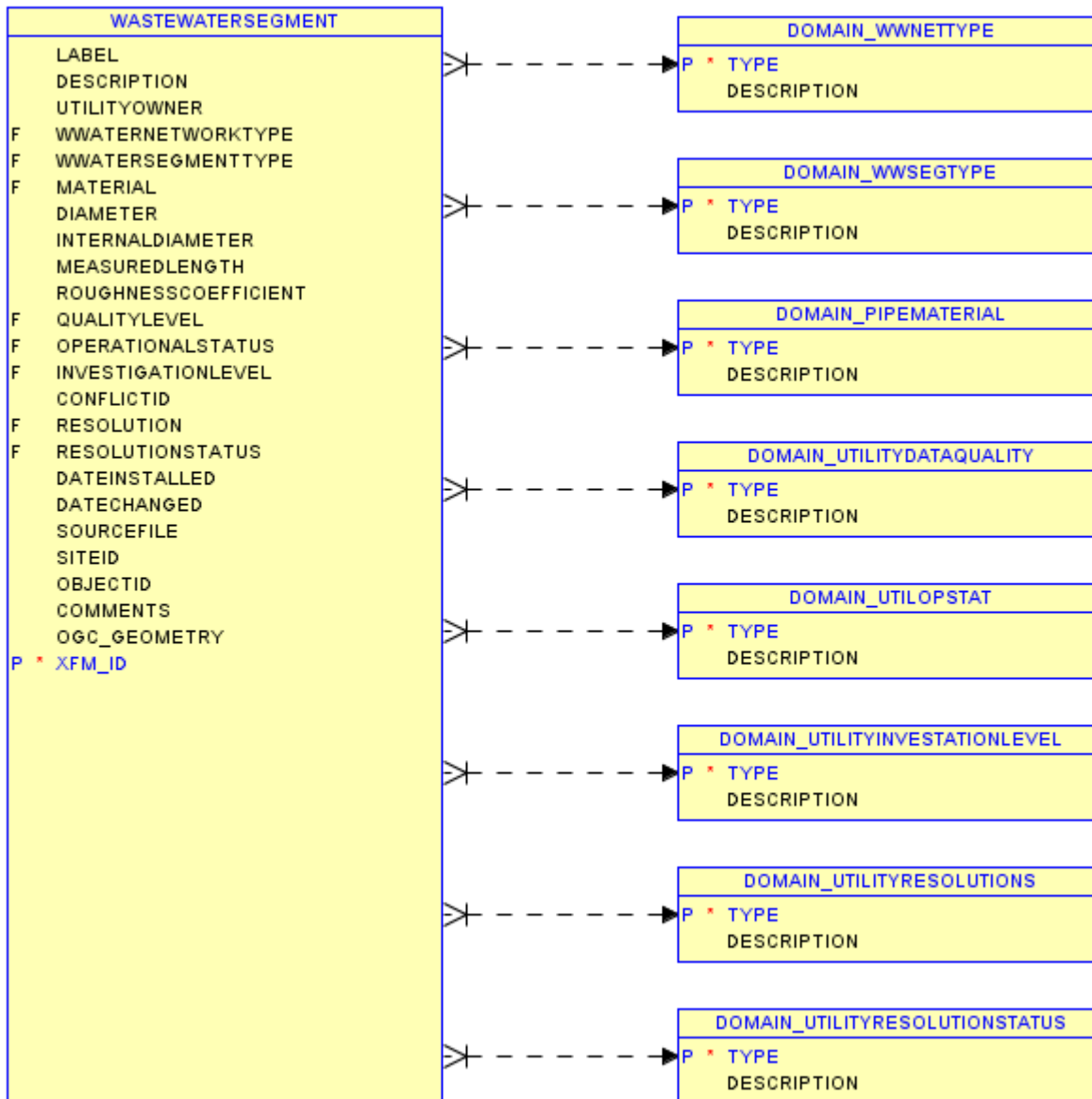

WATERCOURSELINE

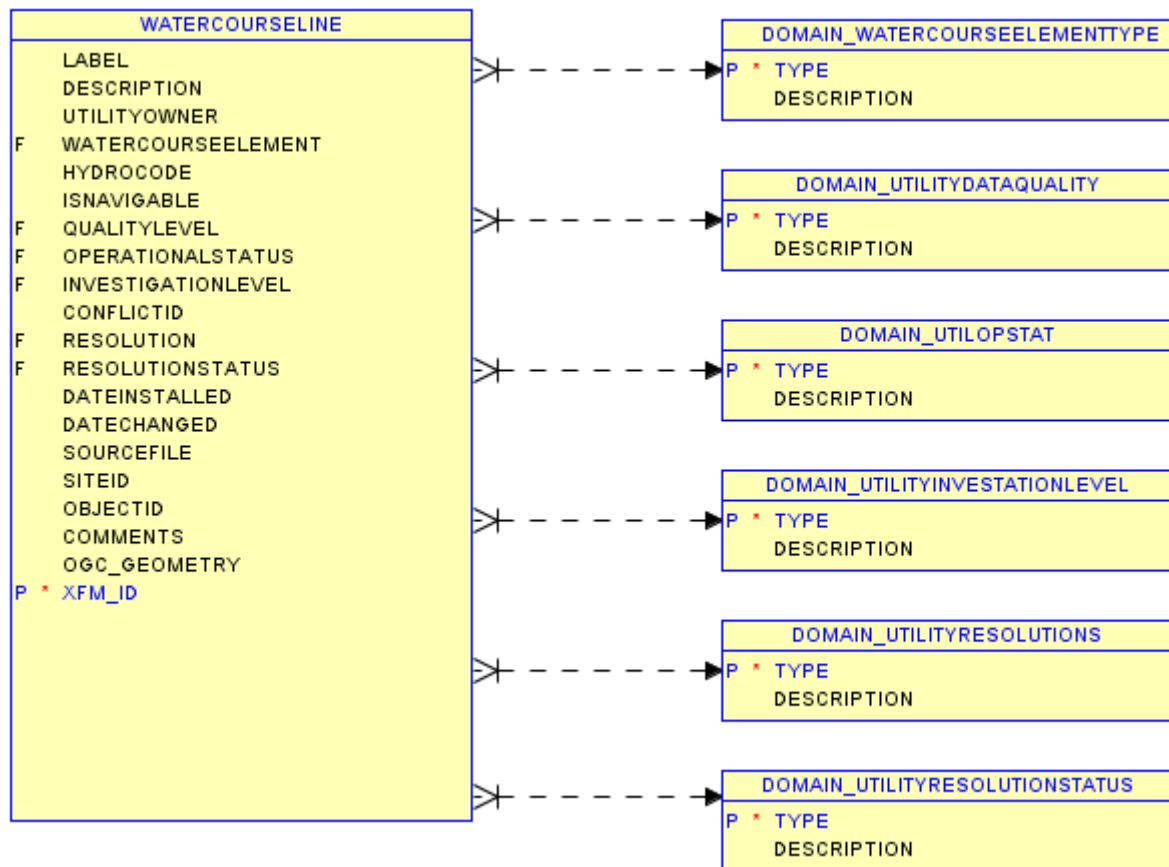

WATERFEATURE

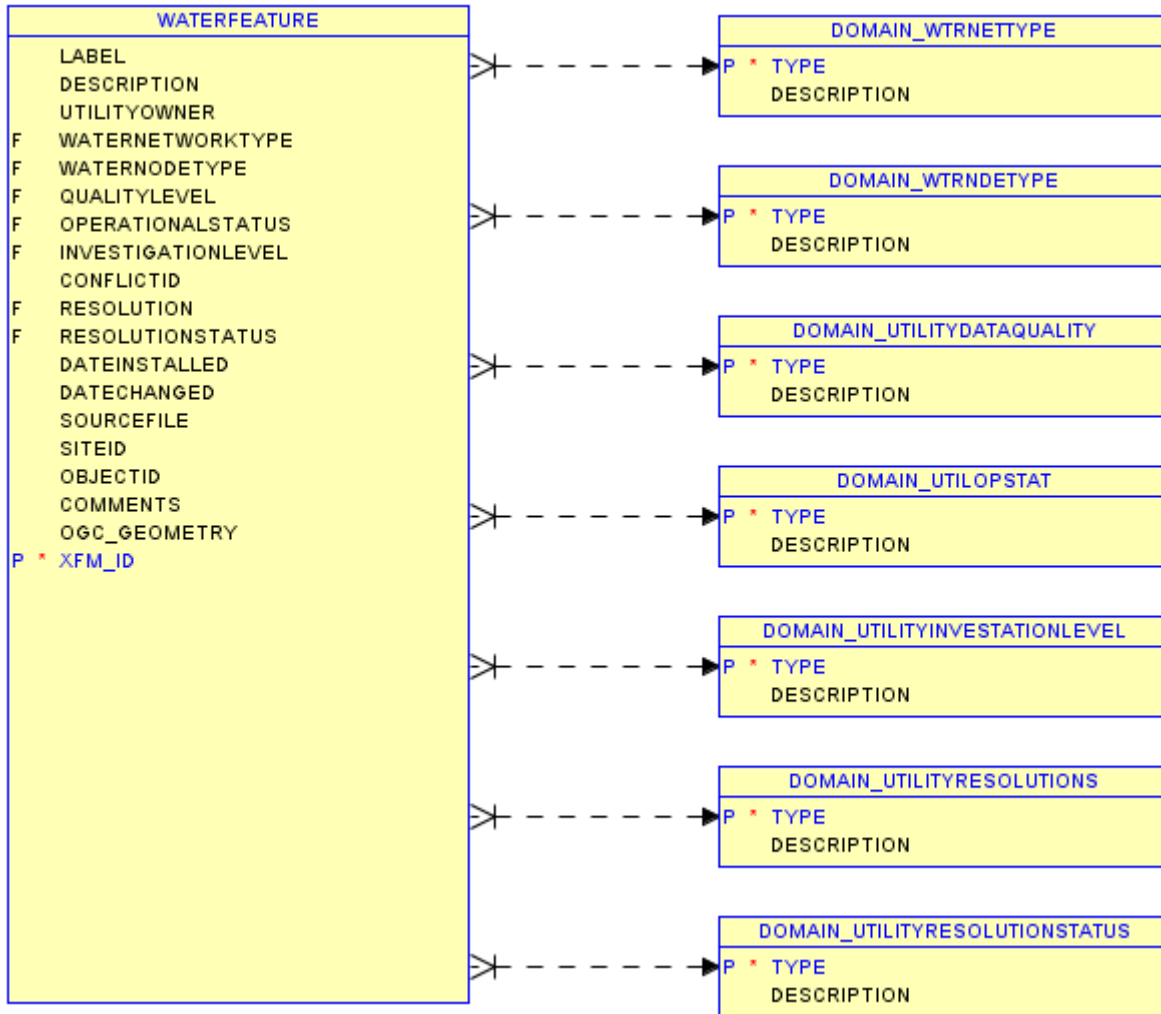

WATERNODE

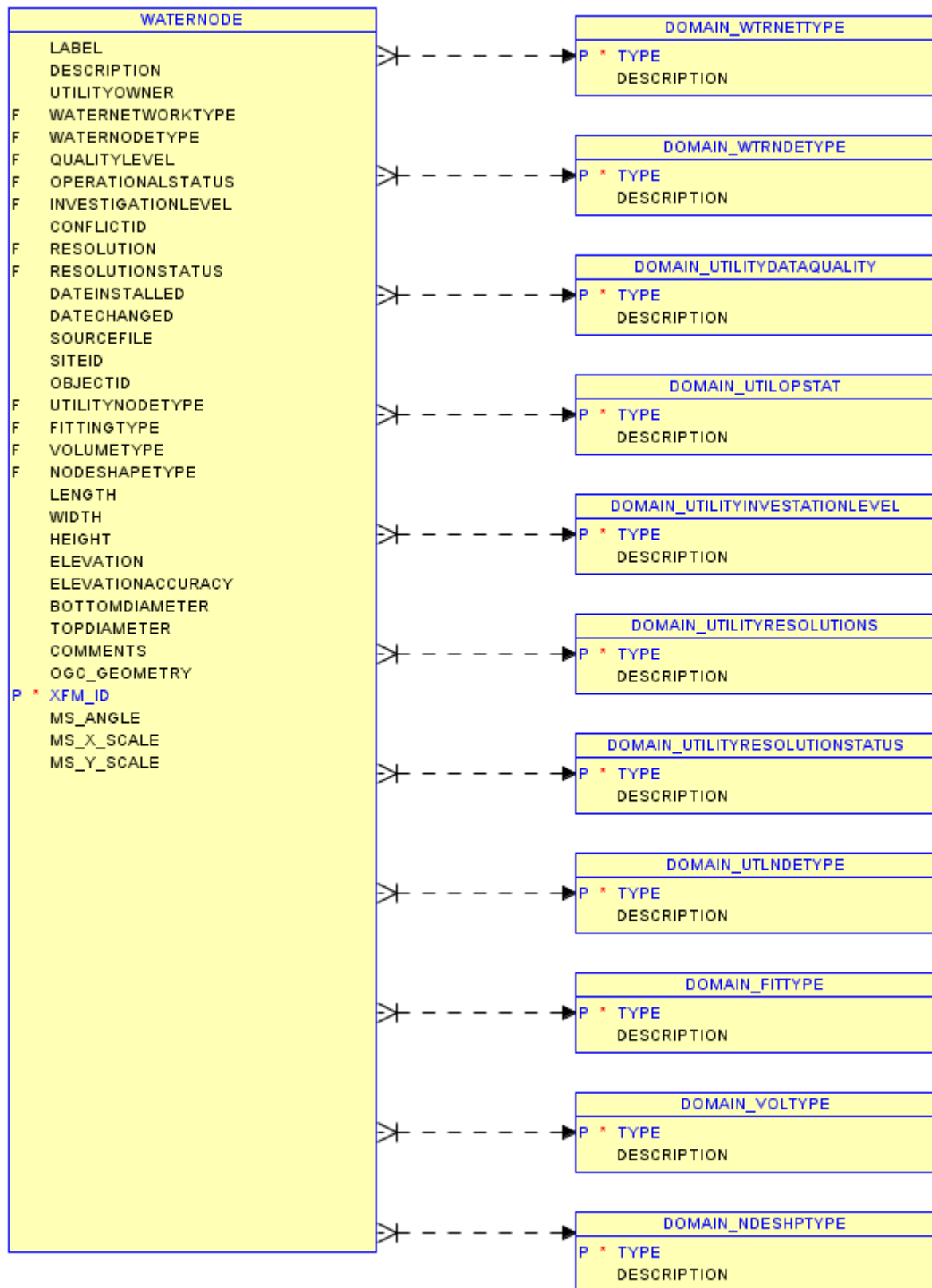

WATERSEGMENT

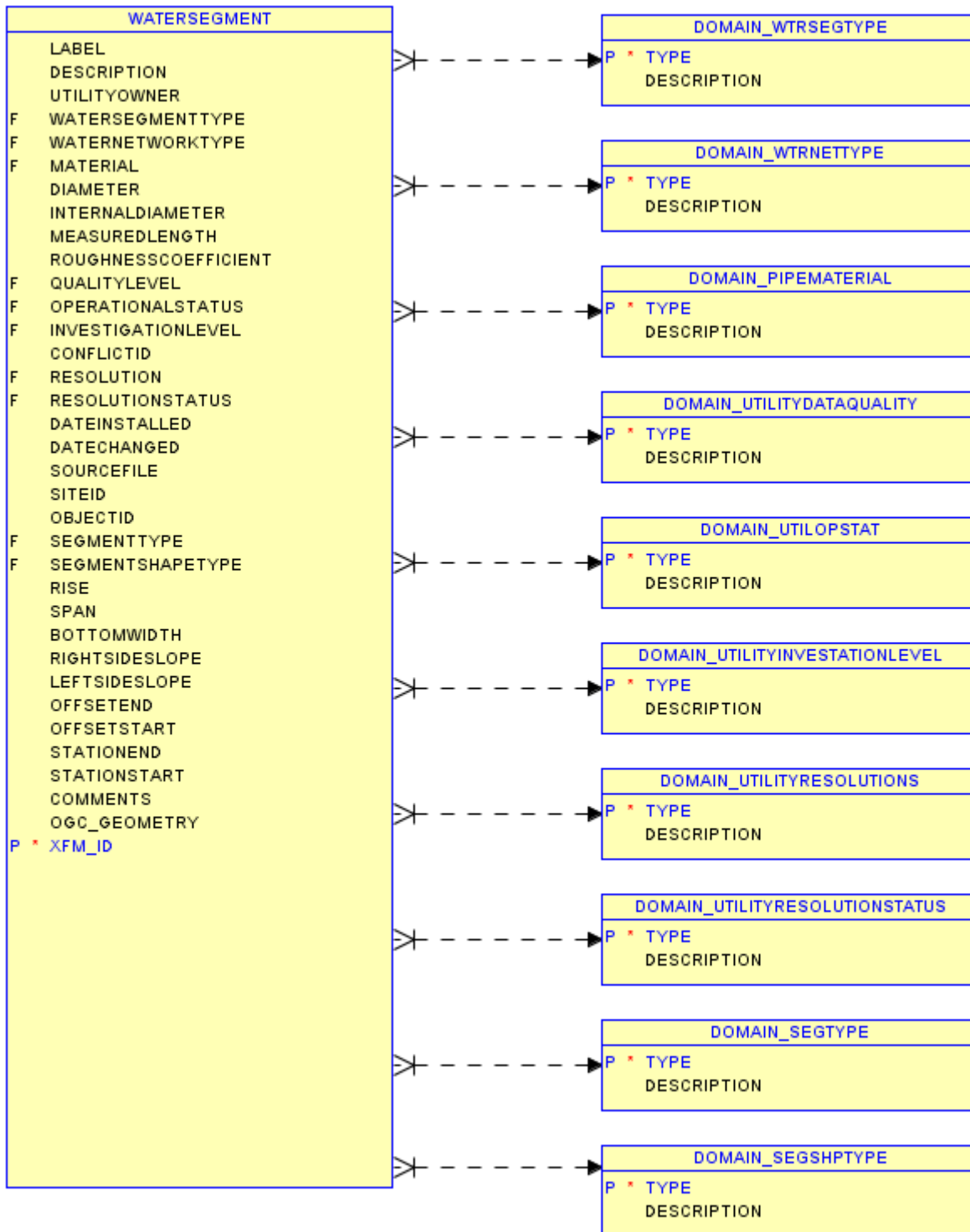

Domain Values

DOMAIN_BRIDGETYPE
Bascule
Covered
FrameExceptCulvert
Lift
Orthotropic
Other
Pontoon
Slab
Suspension
Swing
TBD
Tilt
Truss
TrussDeck
Unclassified

DOMAIN_COMNDETYPE
Access Point
Amplifier
Antenna
DB Splice
Device
FO Distribution Panel
Ground
Impedance Matching
Load Capacitor
Load Coil
Media Converter
Repeater
Sensor

Speaker
Splice
Splitter
Terminal
Terminator
User Defined

DOMAIN_COMNETTYPE
Telephone
CATV
Fiber
User Defined

DOMAIN_COMSEGTYPE
Segmented Cable
Service Loop
User Defined

DOMAIN_CONFLICTRESOL
Utility conflict created
Utility owner informed of utility conflict
Utility conflict resolution strategy selected
Utility conflict resolved

DOMAIN_CONFLICTTYPE
Hard
Soft

DOMAIN_ELEVATIONCONTOURTYPE
APP_IND_DEP
APP_INDEX
APP_INTER
APP_INTER_DEP
INDEX
INDEX_DEP
INTER
INTER_DEP

Other
TBD

DOMAIN_ENDETYPE
Capacitor Bank
Device Protective Device
Exterior Light
Fuse
Generator
Grounding Point
Meter Point
Open Point
Switch
Transformer
Voltage Regulator
User Defined

DOMAIN_ENETTYPE
Power
Lighting
User Defined

DOMAIN_ESEGTYPE
Bus Bar
Primary Overhead Line
Primary Underground Line
Secondary Overhead Line
Secondary Underground Line
Overhead Transmission Line
Transmission Underground Line
Step Transformer
User Defined

DOMAIN_EXTERNALINTERESTTYPE
Agreement
Easement
Informal
Mitigation Area

Right Of Way

DOMAIN_FENCEUSETYPE
Agriculture
Boundary
Cross
GrazingLease
Private
ResidentialArea
Security
VehicleBarrier

DOMAIN_FITTYPE
Coupling
Reducer
Tee
Wye

DOMAIN_GASNDETYPE
Controllable Fitting
Drip
Gas Lamp
Meter Point
Non Controllable Fitting
Odorizer
Pressure Monitoring Device
Regulator
Regulator Station
ReliefValve
Rural Tap
TownBorderStation
Valve
User Defined

Millimetre
Nanometre
NauticalMile
Picometre
StatuteMile
UsSurveyFoot
UsSurveyMile
Yard

DOMAIN_HORIZONTALDATUMTYPE
HARN
HARN_94
NAD_27
NAD_83

DOMAIN_MONUMENTPOINTTYPE
BOUNDARY_NOTAB
BOUNDARY_NUMELE
BOUNDARY_TAB
HORIZ_VERT_3D
HORIZONTAL_2D
HORIZONTAL_3RD_E
HORIZONTAL_3RD_P
HORIZONTAL_ELEV
MINERAL_LOC
VERTICAL_1D
VERTICAL_3RD_R
VERTICAL_3RD_T

DOMAIN_NDESHPTYPE
Rectangular Prism
Cylinder
Cone
Conic Frustrum

DOMAIN_GASNETTYPE
High Pressure
Low Pressure
User Defined

DOMAIN_GASSECTYPE
Main Distribution
Main Transmission
Service Distribution
Service Transmission
User Defined

DOMAIN_GSIP_LENGTHUOM
AstronomicUnit
Centimetre
DataMile
Decafoot
Decakilometre
Decametre
Decifoot
Decimetre
DeciNauticalMile
Fathom
Foot
HalfFoot
HalfHectometre
HalfMetre
Hectofoot
Hectokilometre
Hectometre
Inch
Kilofoot
Kilometre
Kiloyard
Metre
Mmicrometre

DOMAIN_NETWORKSUBTYPE
AutomotiveDiesel
B20
BF1
BF2
BF3
BF44
BF5Heavy
BF5Light
BF6
ChilledWaterReturn
ChilledWaterSupply
CNG
Communications
CraneTrack
DomesticSewage
Driveway
DualTemperatureWaterReturn
DualTemperatureWaterSupply
E85
Electrical
FireProtectionWater
Gas
Helipad
HighTemperatureHotWaterReturn
HighTemperatureHotWaterSupply
Hydrazine
IndustrialWaste
JetA
JetA1
JP10
JP4
JP5
JP7
JP8
JPTS
Kerosene

LowTemperatureHotWaterReturn
LowTemperatureHotWaterSupply
LPG
MarineDiesel
Mogas
NonPotableWater
O250
O278
OilyWaste
OtherApron
OtherReturn
OtherSupply
Otto
ParkingApron
ParkingArea
PotableWater
RailroadTrack
RawWater
Roadway
Runway
SaltWater
ShipsWaste
Sidewalk
SteamReturn
SteamSupply
Stormwater
Taxiway
TreatedWater

DOMAIN_NETWORKTYPE
Communications
Electrical
Gas
Pavement
POL
Railroad
Thermal
Wastewater
Water

DOMAIN_PAVEMENTSECTIONT
AirfieldBridge
Apron
Curb
CurbAndGutter
Driveway
Helipad
Intersection
Overrun
ParkingArea
PedestrianBridge
Roadway
RoadwayBridge
Runway
Shoulder
Sidewalk
Taxiway
Tunnel

DOMAIN_PIPEMATERIAL
Abs
Ac
Al
Armored_Glass
Asbestcement
Bi
Black_Fe
Brick
C
CastIron
Cement
Ci
Cis
Cm
Coatwrapstel
Composolite
Concrete
Corr_Metal
Corr_Steel
Corralbitmen
Corralpavin
Corrmetlbitm
Corrmetpavin
Corrstelbitm
Corrstelpavi
Corrugatedal
Cresotedwood
Cu
Di
Ductilefe
Fept_Steel
Fiber
Fiberglass
Frp
Frv
Galvanizedfe
Galvnizsteel

Gi
Glass
Glass_Lined
Gs
Hastelloy
Hdpe
Heliwound
Inconel
Insulatconcr
Kyn_Steel
Metal
Monel
Multipleclay
Multipletile
Nickel
Other
Othermasonry
Pfa
Plastic
Polyethylene
Polystyrene
Ppe_Steel
Precast
Prestressed
Ptfe
Pvc
Rc
Reinforconcr
Reinfplasmor
Rub_Steel
S
Saran_Lined
Single_Clay
Single_Tile
Stainless_Steel
Steel
Steel_Wraped
Stone

Tan_Steel
Tbd
Terracotta
Tile_Resin
Titanium
Unearthen
Vc
Vitrifidclay
Wi
Wrought_Fe
Zirconium

DOMAIN_POLNDETYPE
Dispenser
FillStand
Filter Separator
Hydrant Outlet
Injector
Loading Arm
Meter
Pump
Relaxation Tank
Strainer
Tank
Valve
User Defined

DOMAIN_POLNETTYPE
Automotive Diesel
B20
BF1
BF2
BF3
BF4
BF5Heavy
BF6
Compressed Natural Gas (CNG)
E85
Hydrazine
Jet A
Jet A1
JP10
JP4
JP5
JP7
JP8
JP (Thermally Stable)
Kerosene
Liquified Petroleum Gas
Marine Diesel
Motor Gasoline (MOGAS)
O-250
O-278
OTTO
User Defined

DOMAIN_POLSECTYPE
Installation Pipeline
Interterminal Pipeline
User Defined

DOMAIN_RAILCONSTRUCTIONTYPE
Access
Auxiliary
Balloon
Branch
Crossover
Loading
Main
Other
Secondary Main
Service
Siding
Spur
Storage
Yard

DOMAIN_RECREATIONAREATYPE
AthleticField
Autotouring
Biking
Boating
Camping
Climbing
EducationalPrograms
Equestrian
FishHatcheries
Fishing
Hiking
HistoricCultural
Hunting
Lodging
MuseumOrVisitorCenter
OffHighwayVehicle
Pet
Picnic
TailwaterArea
WaterSports
WildlifeViewing
WinterSports

DOMAIN_SEGSHPTYPE
Circular
Box
Ellipse
Trapezoid

DOMAIN_SEGTYPE
User Defined
Catalog Segment

DOMAIN_SIGNTYPE
Boundary
Directional
Interpretive
Other
RecArea
RecAreaSiteID
RecSymbol
Regulatory
SafetyWarnings
StandardID
TBD
Traffic

DOMAIN_STRUCTURALCONDITION
BoardedUp
BrokenNoUse
BurntNoUse
BurntUseable
Condemned
Cracked
Damaged
DamageHevUse
DamageLitUse
DamageModUse
DamagHevNo
DamagLitNo
DamagModMo
Dangerous
Fair
FairEstimated
Good
GoodEstimated
GoodNotNew
Habitable
HabitableNo
MinorUse
NewlyBuilt
NewunFinish
NoTrespassng
Other
Poor
PoorEstimated
Quarantined
Radioactive
TBD
UnderConstruct
Unserviceable
Useable
UseableNo

DOMAIN_STRUCTUREMATERIAL
Al
Brick
Builtup
Canvas
Cardboard
Cement
CementBlock
Cinderblock
Cis
Combination
Compo
ConcretBlock
Concrete
ConcretePile
Concrt_And_Steel
Concrt_And_Wood
Earthen
Fiberglass
Glass
Glass_Rein_Plas
Glassblock
Grass
Hard_Surfaced
Hides
Logs
Loose_Boulders
Masnry_And_Steel
Masonry
Masonry_And_Wood
Metal
Other
Painted
Plastic
Precast
Sheetmetal
Snow
Steel

Steel_And_Wood
Steelpile
Stone
Styrofoam
Tbd
Tile
Unsurfaced
Wood
Woodenpile

DOMAIN_SURVEYMETHOD
Ferromatic Locating
GPR
Pothole
RFID
Tracer Wire
LIDAR

DOMAIN_SURVEYSOURCETYPE
LIDAR
Other
SarOrlfsar
SonarMultiBeam
SonarSingleBeam
TBD

DOMAIN_SURVEYTYPE
Controlled Survey
Examination Survey
Passage Survey
Reconnaissance Sketch Survey
Remotely Sensed

DOMAIN_THMNETTYPE
Chilled Water Return
Chilled Water Supply
Dual Temperature Water Return
Dual Temperature Water Supply
High Temperature Hot Water Return
High Temperature Hot Water Supply
Low Temperature Hot Water Return
Low Temperature Hot Water Supply
Steam Return
Steam Supply
User Defined

DOMAIN_THMNODTYPE
Aquastat
Condensate Collector
Control Valve
Expansion Joint
Expansion Loop
Expansion Tank
Fitting
Meter Point
Production Structure
Pump
Relief Valve
Strainer
System Valve
Trap
User Defined

DOMAIN_THMSEGTYPE
Main Line
Service Line
User Defined

DOMAIN_TOWERUSETYPE
Communication
Control
Cooling
Fire
Not_Applicable
Observation
Other
TBD
Training
Water

DOMAIN_TRANSTUNNELTYPE
Canal
Other
Railroad
Road
TBD
Trail

DOMAIN_UTILITYDATAQUALITY
QL-A From subsurface locating
QL-B From surface geophysical locating
QL-C From surveying
QL-D From existing records
Undetermined

DOMAIN_UTILITYFEATURET
cAccessCoverageArea
cAirpipe
cAirPressureDevice
cAirPressureValve
cCableLadder
cDuct
cDuctBank
cElectronicMarker
cEquipment
cManhole
cPathNode
cPathSegment
cPedestal
cRiser
cVault
cVertical
eAnchorGuy
eConduitSystem
eDemarcationPoint
eElectricalFacilitySite
eRiser
eSpanGuy
eSpatialOperationsRecord
eSupportStructure
eSurfaceStructure
eUndergroundStructure
eUtilityArea
gAbandonedGasDevice
gAbandonedGasPipe
gAlcoholInjectionEquipment
gDemarcationPoint
gGasPipeCasing
gLeakSurveyArea
gLineHeater
gPipelineMarker
gSCADASensor
gScrubber

gSpatialOperationsRecord
gStationStructure
gUGEnclosureAccess
gUndergroundEnclosure
gUtilityArea
gUtilityMarker
oAircraftFuelingFacility
oAnode
oAutomaticTankGauging
oCanopy
oCasingSleeve
oDemarcationPoint
oMarineFuelingFacility
oMarineRDFacility
oMarineSpillContainmentBoom
oOWSSystem
oPumpingFacility
oPumpMotor
oSCADASensor
oServiceStation
oSpatialOperationsRecord
oSpillContainment
oSpillReport
oTankTruckCarRDFacility
oUGEnclosureAccess
oUndergroundEnclosure
oUtilityArea
oUtilityMarker
oValvePit
rArea
sAnode
sCasing
sDemarcationPoint
sPretreatmentDevice
sPumpStation
sSamplingSite
sSCADASensor
sSepticTank

sSpatialOperationsRecord
sStandbyPower
sThrustProtection
sUGEnclosureAccess
sUndergroundEnclosure
sUtilityArea
sUtilityMarker
tCasing
tDemarcationPoint
tSamplingSite
tSCADASensor
tSpatialOperationsRecord
tSupport
tUGEnclosureAccess
tUndergroundEnclosure
tUtilityArea
tUtilityMarker
wAnode
wCasing
wDemarcationPoint
wSamplingSite
wSCADASensor
wSpatialOperationsRecord
wStandbyPower
wSurgeReliefTank
wThrustProtection
wUGEnclosureAccess
wUndergroundEnclosure
wUtilityArea
wUtilityMarker
uChamber
uTrench
ePedestalPole
wInlet
eConductor

DOMAIN_UTILITYINVESTATIONLE
LandSurvey
EngineeringSurvey
InformationalSurvey

DOMAIN_UTILITYRESOLUTIONS
None
Evaluate
Survey
Design
Construct
Maintain

DOMAIN_UTILITYRESOLUTIONSTA
None
Submitted
Reviewed
Accepted
Resolved
Finalized

DOMAIN_UTILOPSTAT
Abandoned
InService
Proposed
Removed
Temporary
UnderConstruction

DOMAIN_UTLNDETYPE
Fitting
Volumetric

DOMAIN_VERTICALDATUMTYPE
ALWP
DHQ
DLQ
DTL
GT
HWI
LWI
LWRP
MHHW
MHW
MLG
MLLW
MLW
MN
MSL
MTL
NAVD_88
NGVD_29
NTDE
OTHER
SD
TBD

DOMAIN_VOLTTYPE
User Defined
Catalog Node

DOMAIN_WALLTYPE
Brick
Concrete
Stone
Timber

DOMAIN_WATERCOURSELEMENTY
GeometricCenterline
LeftBank
RightBank
Thalweg
ThruWaterbody
Toe

DOMAIN_WTRNDETYPE
Back Flow Prevention Device
Control Valve
Fitting
Hydrant
Meter Point
Pressure Reducing Station
Production Structure
Pump
Relief Valve
Storage Structure
System Valve
User Defined

DOMAIN_WTRNETTYPE
Fire Protection
NonPotable
Potable
Raw Water
Salt Water
Treated Water
User Defined

DOMAIN_WTRSEGTYPE
Main Line
Service Line
User Defined

DOMAIN_WWNDETYPE
Clean Out
Fitting
Manhole
Meter Point
Pump
Release Valve
System Valve
Treatment Plant
Pumping Station
User Defined

DOMAIN_WWNETTYPE
Domestic Sewage
Industrial Waste
Oily Waste
Ships Waste
Storm Water
User Defined

DOMAIN_WWSEGTYPE
Force Main
Gravity Main
Lateral Line
User Defined

DOMAIN_COORDINATESYSTEM
AK-10
AK-1
AK-2
AK-3
AK-4
AK-5
AK-6
AK-7
AK-8
AK-9
AK83-10F
AK83-10
AK83-1F
AK83-1
AK83-2F
AK83-2
AK83-3F
AK83-3
AK83-4F
AK83-4
AK83-5F
AK83-5
AK83-6F
AK83-6
AK83-7F
AK83-7
AK83-8F
AK83-8
AK83-9F
AK83-9
AL-E
AL-W
AL83-EF
AL83-E
AL83-WF
AL83-W

ALHP-EF
ALHP-E
ALHP-WF
ALHP-W
AR-N
AR-S
AR83-NF
AR83-N
AR83-SF
AR83-S
ARHP-NF
ARHP-N
ARHP-SF
ARHP-S
AZ-C
AZ-E
AZ-W
AZ83-CCM
AZ83-CF
AZ83-CIF
AZ83-C
AZ83-EF
AZ83-EIF
AZ83-E
AZ83-WF
AZ83-WIF
AZ83-W
AZHP-CF
AZHP-CIF
AZHP-C
AZHP-EF
AZHP-EIF
AZHP-E
AZHP-WF
AZHP-WIF
AZHP-W
CA-III

CA-II
CA-IV
CA-I
CA-VII
CA-VI
CA-V
CA83-IF
CA83-IIF
CA83-III
CA83-II
CA83-IVF
CA83-IV
CA83-I
CA83-VF
CA83-VIF
CA83-VI
CA83-V
CA83IIIF
CAHP-IF
CAHP-IIF
CAHP-III
CAHP-II
CAHP-IVF
CAHP-IV
CAHP-I
CAHP-VF
CAHP-VIF
CAHP-VI
CAHP-V
CAHPIIIF
CO-C
CO-N
CO-S
CO83-CF
CO83-C
CO83-NF
CO83-N

CO83-SF
CO83-S
COHP-CF
COHP-C
COHP-NF
COHP-N
COHP-SF
COHP-S
CT83F
CT83
CTHPF
CTHP
CT
DE83F
DE83
DEHPF
DEHP
DE
FL-E
FL-N
FL-W
FL83-EF
FL83-E
FL83-NF
FL83-N
FL83-WF
FL83-W
FLHP-EF
FLHP-E
FLHP-NF
FLHP-N
FLHP-WF
FLHP-W
GA-E
GA-W
GA83-EF
GA83-E

GA83-WF
GA83-W
GAHP-EF
GAHP-E
GAHP-WF
GAHP-W
HI-1
HI-2
HI-3
HI-4
HI-5
HI83-1F
HI83-1
HI83-2F
HI83-2
HI83-3F
HI83-3
HI83-4F
HI83-4
HI83-5F
HI83-5
HIHP-1
HIHP-2
HIHP-3
HIHP-4
HIHP-5
IA-N
IA-S
IA83-NF
IA83-N
IA83-SF
IA83-S
IAHP-NF
IAHP-N
IAHP-SF
IAHP-S
ID-C

ID-E
ID-W
ID83-CF
ID83-C
ID83-EF
ID83-E
ID83-WF
ID83-W
IDHP-CF
IDHP-C
IDHP-EF
IDHP-E
IDHP-WF
IDHP-W
IL-E
IL-W
IL83-EF
IL83-E
IL83-WF
IL83-W
ILHP-EF
ILHP-E
ILHP-WF
ILHP-W
ILLIMAP
IN-E
IN-W
IN83-EF
IN83-E
IN83-WF
IN83-W
INHP-EF
INHP-E
INHP-WF
INHP-W
KS-N
KS-S

KS83-NF
KS83-N
KS83-SF
KS83-S
KSHP-NF
KSHP-N
KSHP-SF
KSHP-S
KY-N
KY-S
KY83-NF
KY83-N
KY83-SF
KY83-S
KYHP-NF
KYHP-N
KYHP-SF
KYHP-S
LA-N
LA-O
LA-S
LA83-NF
LA83-N
LA83-OF
LA83-O
LA83-SF
LA83-S
LAHP-NF
LAHP-N
LAHP-OF
LAHP-O
LAHP-SF
LAHP-S
LL-83
LL84
MA27-IS
MA83-ISF

MA83-IS
MA83F
MA83
MAHP-ISF
MAHP-IS
MAHPF
MAHP
MA
MD83F
MD83
MDHPF
MDHP
MD
ME-E
ME-W
ME83-EF
ME83-E
ME83-WF
ME83-W
MEHP-EF
MEHP-E
MEHP-WF
MEHP-W
MI27-C
MI27-N
MI27-S
MI83-CF
MI83-CIF
MI83-C
MI83-NF
MI83-NIF
MI83-N
MI83-SF
MI83-SIF
MI83-S
MIHP-CF
MIHP-CIF

MIHP-C
MIHP-NF
MIHP-NIF
MIHP-N
MIHP-SF
MIHP-SIF
MIHP-S
MN-C
MN-N
MN-S
MN83-CF
MN83-C
MN83-NF
MN83-N
MN83-SF
MN83-S
MNHP-CF
MNHP-C
MNHP-NF
MNHP-N
MNHP-SF
MNHP-S
MO-C
MO-E
MO-W
MO83-CF
MO83-C
MO83-EF
MO83-E
MO83-WF
MO83-W
MOHP-CF
MOHP-C
MOHP-EF
MOHP-E
MOHP-WF
MOHP-W

MS-E
MS-W
MS83-EF
MS83-E
MS83-TM
MS83-WF
MS83-W
MSHP-EF
MSHP-E
MSHP-WF
MSHP-W
MT-C
MT-N
MT-S
MT83F
MT83IF
MT83
MTHPF
MTHPIF
MTHP
NB-N
NB-S
NB83F
NB83
NBHPP
NBHP
NC83F
NC83
NCHPF
NCHP
NC
ND-N
ND-S
ND83-NF
ND83-N
ND83-SF
ND83-S

NDHP-NF
NDHP-N
NDHP-SF
NDHP-S
NE-N
NE-S
NE83F
NE83
NH83F
NH83
NHHPF
NHHP
NH
NJ83F
NJ83
NJHPF
NJHP
NJ
NM-C
NM-E
NM-W
NM83-CF
NM83-C
NM83-EF
NM83-E
NM83-WF
NM83-W
NMHP-CF
NMHP-C
NMHP-EF
NMHP-E
NMHP-WF
NMHP-W
NV-C
NV-E
NV-W
NV83-CF

NV83-C
NV83-EF
NV83-E
NV83-WF
NV83-W
NVHP-CF
NVHP-C
NVHP-EF
NVHP-E
NVHP-WF
NVHP-W
NY-C
NY-E
NY-LI
NY-W
NY83-CF
NY83-C
NY83-EF
NY83-E
NY83-LIF
NY83-LI
NY83-WF
NY83-W
NYHP-CF
NYHP-C
NYHP-EF
NYHP-E
NYHP-LIF
NYHP-LI
NYHP-WF
NYHP-W
OH-N
OH-S
OH83-NF
OH83-N
OH83-SF
OH83-S

OHHP-NF
OHHP-N
OHHP-SF
OHHP-S
OK-N
OK-S
OK83-NF
OK83-N
OK83-SF
OK83-S
OKHP-NF
OKHP-N
OKHP-SF
OKHP-S
OR-N
OR-S
OR83-NF
OR83-NIF
OR83-N
OR83-SF
OR83-SIF
OR83-SSCGIS
OR83-S
ORHP-NF
ORHP-NIF
ORHP-N
ORHP-SF
ORHP-SIF
ORHP-S
PA-N
PA-S
PA83-NF
PA83-N
PA83-SF
PA83-S
PAHP-NF
PAHP-N

PAHP-SF
PAHP-S
PR-1
PR-2
PR83F
PR83
PRHPF
PRHP
RI83F
RI83
RIHPF
RIHP
RI
SC-N
SC-S
SC83F
SC83IF
SC83
SCHPF
SCHPIF
SCHP
SD-N
SD-S
SD83-NF
SD83-N
SD83-SF
SD83-S
SDHP-NF
SDHP-N
SDHP-SF
SDHP-S
TN83F
TN83
TNHPF
TNHP
TN
TX-C

TX-NC
TX-N
TX-SC
TX-S
TX83-CF
TX83-C
TX83-NCF
TX83-NC
TX83-NF
TX83-N
TX83-SCF
TX83-SC
TX83-SF
TX83-S
TXHP-CF
TXHP-C
TXHP-NCF
TXHP-NC
TXHP-NF
TXHP-N
TXHP-SCF
TXHP-SC
TXHP-SF
TXHP-S
UT-C
UT-N
UT-S
UT83-CF
UT83-CIF
UT83-C
UT83-NF
UT83-NIF
UT83-N
UT83-SF
UT83-SIF
UT83-S
UTHP-CF

UTHP-CIF
UTHP-C
UTHP-NF
UTHP-NIF
UTHP-N
UTHP-SF
UTHP-SIF
UTHP-S
UTM27-10F
UTM27-10IF
UTM27-10
UTM27-11F
UTM27-11IF
UTM27-11
UTM27-12F
UTM27-12IF
UTM27-12
UTM27-13F
UTM27-13IF
UTM27-13
UTM27-14F
UTM27-14IF
UTM27-14
UTM27-15F
UTM27-15IF
UTM27-15
UTM27-16F
UTM27-16IF
UTM27-16
UTM27-17F
UTM27-17IF
UTM27-17
UTM27-18F
UTM27-18IF
UTM27-18
UTM27-19F
UTM27-19IF

UTM27-19
UTM27-1N
UTM27-1
UTM27-20F
UTM27-20IF
UTM27-20
UTM27-21F
UTM27-21IF
UTM27-21
UTM27-22F
UTM27-22IF
UTM27-22
UTM27-23F
UTM27-23IF
UTM27-23
UTM27-2N
UTM27-2
UTM27-3F
UTM27-3IF
UTM27-3
UTM27-4F
UTM27-4IF
UTM27-4
UTM27-58
UTM27-59
UTM27-5F
UTM27-5IF
UTM27-5
UTM27-60
UTM27-6F
UTM27-6IF
UTM27-6
UTM27-7F
UTM27-7IF
UTM27-7
UTM27-8F
UTM27-8IF

UTM27-8
UTM27-9F
UTM27-9IF
UTM27-9
UTM83-10F
UTM83-10IF
UTM83-10
UTM83-11F
UTM83-11IF
UTM83-11
UTM83-12F
UTM83-12IF
UTM83-12
UTM83-13F
UTM83-13IF
UTM83-13
UTM83-14F
UTM83-14IF
UTM83-14
UTM83-15F
UTM83-15IF
UTM83-15
UTM83-16F
UTM83-16IF
UTM83-16
UTM83-17F
UTM83-17IF
UTM83-17
UTM83-18F
UTM83-18IF
UTM83-18
UTM83-19F
UTM83-19IF
UTM83-19
UTM83-1
UTM83-20F
UTM83-20IF

UTM83-20
UTM83-21F
UTM83-21IF
UTM83-21
UTM83-22F
UTM83-22IF
UTM83-22
UTM83-23
UTM83-2
UTM83-3F
UTM83-3
UTM83-4F
UTM83-4
UTM83-58
UTM83-59
UTM83-5F
UTM83-5IF
UTM83-5
UTM83-60
UTM83-6F
UTM83-6IF
UTM83-6
UTM83-7F
UTM83-7IF
UTM83-7
UTM83-8F
UTM83-8IF
UTM83-8
UTM83-9F
UTM83-9IF
UTM83-9
UTM84-10N
UTM84-10S
UTM84-11N
UTM84-11S
UTM84-12N
UTM84-12S

UTM84-13N
UTM84-13S
UTM84-14N
UTM84-14S
UTM84-15N
UTM84-15S
UTM84-16N
UTM84-16S
UTM84-17N
UTM84-17S
UTM84-18N
UTM84-18S
UTM84-19N
UTM84-19S
UTM84-1N
UTM84-1S
UTM84-20N
UTM84-20S
UTM84-21N
UTM84-21S
UTM84-22N
UTM84-22S
UTM84-23N
UTM84-23S
UTM84-24N
UTM84-24S
UTM84-25N
UTM84-25S
UTM84-26N
UTM84-26S
UTM84-27N
UTM84-27S
UTM84-28N
UTM84-28S
UTM84-29N
UTM84-29S
UTM84-2N

UTM84-2S
UTM84-30N
UTM84-30S
UTM84-31N
UTM84-31S
UTM84-32N
UTM84-32S
UTM84-33N
UTM84-33S
UTM84-34N
UTM84-34S
UTM84-35N
UTM84-35S
UTM84-36N
UTM84-36S
UTM84-37N
UTM84-37S
UTM84-38N
UTM84-38S
UTM84-39N
UTM84-39S
UTM84-3N
UTM84-3S
UTM84-40N
UTM84-40S
UTM84-41N
UTM84-41S
UTM84-42N
UTM84-42S
UTM84-43N
UTM84-43S
UTM84-44N
UTM84-44S
UTM84-45N
UTM84-45S
UTM84-46N
UTM84-46S

UTM84-47N
UTM84-47S
UTM84-48N
UTM84-48S
UTM84-49N
UTM84-49S
UTM84-4N
UTM84-4S
UTM84-50N
UTM84-50S
UTM84-51N
UTM84-51S
UTM84-52N
UTM84-52S
UTM84-53N
UTM84-53S
UTM84-54N
UTM84-54S
UTM84-55N
UTM84-55S
UTM84-56N
UTM84-56S
UTM84-57N
UTM84-57S
UTM84-58N
UTM84-58S
UTM84-59N
UTM84-59S
UTM84-5N
UTM84-5S
UTM84-60N
UTM84-60S
UTM84-6N
UTM84-6S
UTM84-7N
UTM84-7S
UTM84-8N

UTM84-8S
UTM84-9N
UTM84-9S
UTM89-30N
UTMHP-10F
UTMHP-10IF
UTMHP-10
UTMHP-11F
UTMHP-11IF
UTMHP-11
UTMHP-12F
UTMHP-12IF
UTMHP-12
UTMHP-13F
UTMHP-13IF
UTMHP-13
UTMHP-14F
UTMHP-14IF
UTMHP-14
UTMHP-15F
UTMHP-15IF
UTMHP-15
UTMHP-16F
UTMHP-16IF
UTMHP-16
UTMHP-17F
UTMHP-17IF
UTMHP-17
UTMHP-18F
UTMHP-18IF
UTMHP-18
VA-N
VA-S
VA83-NF
VA83-N
VA83-SF
VA83-S

VAHP-NF
VAHP-N
VAHP-SF
VAHP-S
VT83F
VT83
VTHPF
VTHP
VT
WA-N
WA-S
WA83-NF
WA83-N
WA83-SF
WA83-S
WAHP-NF
WAHP-N
WAHP-SF
WAHP-S
WI-C
WI-N
WI-S
WI83-CF
WI83-C
WI83-NF
WI83-N
WI83-SF
WI83-S
WIHP-CF
WIHP-C
WIHP-NF
WIHP-N
WIHP-SF
WIHP-S
WV-N
WV-S
WV83-NF

WV83-N
WV83-SF
WV83-S
WVHP-NF
WVHP-N
WVHP-SF
WVHP-S
WY-EC
WY-E
WY-WC
WY-W
WY83-ECF
WY83-EF
WY83-WCF
WY83-WF
WYHP-ECF
WYHP-EF
WYHP-WCF
WYHP-WF

APPENDIX B

Oracle Spatial DDL

```
-----
-- Feature Tables
-----
```

```
-----
-- Table BRIDGE
-----
```

```
DROP TABLE "GIS"."BRIDGE" cascade constraints;
CREATE TABLE "GIS"."BRIDGE"
( "LABEL" VARCHAR2(80 BYTE),
  "DESCRIPTION" VARCHAR2(1024 BYTE),
  "UTILITYOWNER" VARCHAR2(80 BYTE),
  "BRIDGETYPE" VARCHAR2(18 BYTE),
  "HORIZONTALCLEARANCE" NUMBER,
  "HORIZONTALCLEARANCEUOM" VARCHAR2(16 BYTE),
  "ISFIXED" VARCHAR2(5 BYTE),
  "LOWCHORDELEVATION" NUMBER,
  "LOWCHORDELEVATIONUOM" VARCHAR2(16 BYTE),
  "REFERENCEELEVATION" NUMBER,
  "REFERENCEELEVDESCRIPTION" VARCHAR2(1024 BYTE),
  "REFERENCEELEVUOM" VARCHAR2(16 BYTE),
  "REFERENCEELEVVERTDATUM" VARCHAR2(7 BYTE),
  "TOPWIDTH" NUMBER,
  "VERTCLEARANCECLOSED" NUMBER,
  "VERTCLEARANCECLOSEDUOM" VARCHAR2(16 BYTE),
  "VERTCLEARANCEOPEN" NUMBER,
  "VERTCLEARANCEOPENUOM" VARCHAR2(16 BYTE),
  "QUALITYLEVEL" VARCHAR2(40 BYTE),
  "OPERATIONALSTATUS" VARCHAR2(17 BYTE),
  "INVESTIGATIONLEVEL" VARCHAR2(25 BYTE),
  "CONFLICTID" VARCHAR2(25 BYTE),
  "RESOLUTION" VARCHAR2(25 BYTE),
  "RESOLUTIONSTATUS" VARCHAR2(25 BYTE),
  "DATEINSTALLED" DATE,
  "DATECHANGED" DATE,
  "SOURCEFILE" VARCHAR2(60 BYTE),
  "SITEID" NUMBER,
  "OBJECTID" NUMBER,
  "COMMENTS" VARCHAR2(1024 BYTE),
  "OGC_GEOMETRY" "MDSYS"."SDO_GEOMETRY" ,
  "XFM_ID" VARCHAR2(36 BYTE)
) ;
```

```
-----
-- Table BUILDING
-----
```

```
DROP TABLE "GIS"."BUILDING" cascade constraints;
CREATE TABLE "GIS"."BUILDING"
( "LABEL" VARCHAR2(80 BYTE),
  "DESCRIPTION" VARCHAR2(1024 BYTE),
  "UTILITYOWNER" VARCHAR2(80 BYTE),
  "QUALITYLEVEL" VARCHAR2(40 BYTE),
  "OPERATIONALSTATUS" VARCHAR2(17 BYTE),
  "INVESTIGATIONLEVEL" VARCHAR2(25 BYTE),
  "CONFLICTID" VARCHAR2(25 BYTE),
```

```

"RESOLUTION" VARCHAR2(25 BYTE),
"RESOLUTIONSTATUS" VARCHAR2(25 BYTE),
"DATEINSTALLED" DATE,
"DATECHANGED" DATE,
"SOURCEFILE" VARCHAR2(60 BYTE),
"SITEID" NUMBER,
"OBJECTID" NUMBER,
"COMMENTS" VARCHAR2(1024 BYTE),
"OGC_GEOMETRY" "MDSYS"."SDO_GEOMETRY" ,
"XFM_ID" VARCHAR2(36 BYTE)
);

```

```
-- Table COMMUNICATIONNODE
```

```

DROP TABLE "GIS"."COMMUNICATIONNODE" cascade constraints;
CREATE TABLE "GIS"."COMMUNICATIONNODE"
( "LABEL" VARCHAR2(80 BYTE),
"DESCRIPTION" VARCHAR2(1024 BYTE),
"UTILITYOWNER" VARCHAR2(80 BYTE),
"COMMNETWORKTYPE" VARCHAR2(80 BYTE),
"COMMNODETYPE" VARCHAR2(80 BYTE),
"QUALITYLEVEL" VARCHAR2(40 BYTE),
"OPERATIONALSTATUS" VARCHAR2(17 BYTE),
"INVESTIGATIONLEVEL" VARCHAR2(25 BYTE),
"CONFLICTID" VARCHAR2(25 BYTE),
"RESOLUTION" VARCHAR2(25 BYTE),
"RESOLUTIONSTATUS" VARCHAR2(25 BYTE),
"DATEINSTALLED" DATE,
"DATECHANGED" DATE,
"SOURCEFILE" VARCHAR2(60 BYTE),
"SITEID" NUMBER,
"OBJECTID" NUMBER,
"UTILITYNODETYPE" VARCHAR2(80 BYTE),
"FITTINGTYPE" VARCHAR2(80 BYTE),
"VOLUMETYPE" VARCHAR2(80 BYTE),
"NODESHAPETYPE" VARCHAR2(80 BYTE),
"LENGTH" NUMBER,
"WIDTH" NUMBER,
"HEIGHT" NUMBER,
"ELEVATION" NUMBER,
"ELEVATIONACCURACY" NUMBER,
"BOTTOMDIAMETER" NUMBER,
"TOPDIAMETER" NUMBER,
"COMMENTS" VARCHAR2(1024 BYTE),
"OGC_GEOMETRY" "MDSYS"."SDO_GEOMETRY" ,
"XFM_ID" VARCHAR2(36 BYTE),
"MS_ANGLE" NUMBER,
"MS_X_SCALE" NUMBER,
"MS_Y_SCALE" NUMBER
);

```

```
-- Table COMMUNICATIONSEGMENT
```

```

DROP TABLE "GIS"."COMMUNICATIONSEGMENT" cascade constraints;
CREATE TABLE "GIS"."COMMUNICATIONSEGMENT"
( "LABEL" VARCHAR2(80 BYTE),

```

```

"DESCRIPTION" VARCHAR2(1024 BYTE),
"UTILITYOWNER" VARCHAR2(80 BYTE),
"COMMNETWORKTYPE" VARCHAR2(80 BYTE),
"COMMSEGMENTTYPE" VARCHAR2(80 BYTE),
"MATERIAL" VARCHAR2(25 BYTE),
"DIAMETER" NUMBER,
"MEASUREDLENGTH" NUMBER,
"QUALITYLEVEL" VARCHAR2(40 BYTE),
"OPERATIONALSTATUS" VARCHAR2(17 BYTE),
"INVESTIGATIONLEVEL" VARCHAR2(25 BYTE),
"CONFLICTID" VARCHAR2(25 BYTE),
"RESOLUTION" VARCHAR2(25 BYTE),
"RESOLUTIONSTATUS" VARCHAR2(25 BYTE),
"DATEINSTALLED" DATE,
"DATECHANGED" DATE,
"SOURCEFILE" VARCHAR2(60 BYTE),
"SITEID" NUMBER,
"OBJECTID" NUMBER,
"SEGMENTTYPE" VARCHAR2(80 BYTE),
"SEGMENTSHAPETYPE" VARCHAR2(80 BYTE),
"RISE" NUMBER,
"SPAN" NUMBER,
"BOTTOMWIDTH" NUMBER,
"RIGHTSIDESLOPE" NUMBER,
"LEFTSIDESLOPE" NUMBER,
"OFFSETEND" VARCHAR2(25 BYTE),
"OFFSETSTART" VARCHAR2(25 BYTE),
"STATIONEND" VARCHAR2(25 BYTE),
"STATIONSTART" VARCHAR2(25 BYTE),
"COMMENTS" VARCHAR2(1024 BYTE),
"OGC_GEOMETRY" "MDSYS"."SDO_GEOMETRY" ,
"XFM_ID" VARCHAR2(36 BYTE)
);

```

```
-- Table CONFLICTNODE
```

```

DROP TABLE "GIS"."CONFLICTNODE" cascade constraints;
CREATE TABLE "GIS"."CONFLICTNODE"
( "LABEL" VARCHAR2(80 BYTE),
"DESCRIPTION" VARCHAR2(1024 BYTE),
"QUALITYLEVEL" VARCHAR2(40 BYTE),
"CONFLICTID" VARCHAR2(25 BYTE),
"CONFLICTTYPE" VARCHAR2(25 BYTE),
"DEPTH" NUMBER,
"STATIONEND" VARCHAR2(25 BYTE),
"STATIONSTART" VARCHAR2(25 BYTE),
"OFFSETEND" VARCHAR2(25 BYTE),
"OFFSETSTART" VARCHAR2(25 BYTE),
"RESPONSIBLEPARTY" VARCHAR2(80 BYTE),
"CONFLICTER" VARCHAR2(25 BYTE),
"CONFLICTEE" VARCHAR2(25 BYTE),
"CURRENTSTATUS" VARCHAR2(25 BYTE),
"RECOMMENDATION" VARCHAR2(25 BYTE),
"RESOLUTION" VARCHAR2(25 BYTE),
"RESOLUTIONDESCR" VARCHAR2(1024 BYTE),
"REQUIRESTESTHOLE" VARCHAR2(5 BYTE),

```

```

"SITEID" NUMBER,
"OBJECTID" NUMBER,
"COMMENTS" VARCHAR2(1024 BYTE),
"OGC_GEOMETRY" "MDSYS"."SDO_GEOMETRY" ,
"XFM_ID" VARCHAR2(36 BYTE),
"MS_ANGLE" NUMBER,
"MS_X_SCALE" NUMBER,
"MS_Y_SCALE" NUMBER
);

```

```
-- Table CONSTRUCTIONLINE
```

```

DROP TABLE "GIS"."CONSTRUCTIONLINE" cascade constraints;
CREATE TABLE "GIS"."CONSTRUCTIONLINE"
( "LABEL" VARCHAR2(80 BYTE),
"DESCRIPTION" VARCHAR2(1024 BYTE),
"UTILITYOWNER" VARCHAR2(80 BYTE),
"QUALITYLEVEL" VARCHAR2(40 BYTE),
"OPERATIONALSTATUS" VARCHAR2(17 BYTE),
"INVESTIGATIONLEVEL" VARCHAR2(25 BYTE),
"CONFLICTID" VARCHAR2(25 BYTE),
"RESOLUTION" VARCHAR2(25 BYTE),
"RESOLUTIONSTATUS" VARCHAR2(25 BYTE),
"DATEINSTALLED" DATE,
"DATECHANGED" DATE,
"SOURCEFILE" VARCHAR2(60 BYTE),
"SITEID" NUMBER,
"OBJECTID" NUMBER,
"COMMENTS" VARCHAR2(1024 BYTE),
"OGC_GEOMETRY" "MDSYS"."SDO_GEOMETRY" ,
"XFM_ID" VARCHAR2(36 BYTE)
);

```

```
-- Table CONTROLMONUMENTPOINT
```

```

DROP TABLE "GIS"."CONTROLMONUMENTPOINT" cascade constraints;
CREATE TABLE "GIS"."CONTROLMONUMENTPOINT"
( "LABEL" VARCHAR2(80 BYTE),
"DESCRIPTION" VARCHAR2(1024 BYTE),
"UTILITYOWNER" VARCHAR2(80 BYTE),
"HORIZONTALDATUM" VARCHAR2(7 BYTE),
"COLLECTIONVERTICALDATUM" VARCHAR2(7 BYTE),
"MONUMENTPOINTTYPE" VARCHAR2(16 BYTE),
"COORDINATESYSTEM" VARCHAR2(16 BYTE),
"QUALITYLEVEL" VARCHAR2(40 BYTE),
"OPERATIONALSTATUS" VARCHAR2(17 BYTE),
"INVESTIGATIONLEVEL" VARCHAR2(25 BYTE),
"CONFLICTID" VARCHAR2(25 BYTE),
"RESOLUTION" VARCHAR2(25 BYTE),
"RESOLUTIONSTATUS" VARCHAR2(25 BYTE),
"DATEINSTALLED" DATE,
"EPOCHDATE" VARCHAR2(20 BYTE),
"SOURCEFILE" VARCHAR2(60 BYTE),
"SITEID" NUMBER,
"OBJECTID" NUMBER,
"COMMENTS" VARCHAR2(1024 BYTE),

```



```

"OGC_GEOMETRY" "MDSYS"."SDO_GEOMETRY" ,
"XFM_ID" VARCHAR2 (36 BYTE) ,
"MS_ANGLE" NUMBER,
"MS_X_SCALE" NUMBER,
"MS_Y_SCALE" NUMBER
);

```

```
-- Table DOTPERMIT
```

```

DROP TABLE "GIS"."DOTPERMIT" cascade constraints;
CREATE TABLE "GIS"."DOTPERMIT"
( "LABEL" VARCHAR2 (80 BYTE) ,
"DESCRIPTION" VARCHAR2 (1024 BYTE) ,
"UTILITYOWNER" VARCHAR2 (80 BYTE) ,
"QUALITYLEVEL" VARCHAR2 (40 BYTE) ,
"OPERATIONSTATUS" VARCHAR2 (17 BYTE) ,
"INVESTIGATIONLEVEL" VARCHAR2 (25 BYTE) ,
"CONFLICTID" VARCHAR2 (25 BYTE) ,
"RESOLUTION" VARCHAR2 (25 BYTE) ,
"RESOLUTIONSTATUS" VARCHAR2 (25 BYTE) ,
"DATEISSUED" DATE,
"DATECHANGED" DATE,
"SOURCEFILE" VARCHAR2 (60 BYTE) ,
"SITEID" NUMBER,
"OBJECTID" NUMBER,
"COMMENTS" VARCHAR2 (1024 BYTE) ,
"OGC_GEOMETRY" "MDSYS"."SDO_GEOMETRY" ,
"XFM_ID" VARCHAR2 (36 BYTE)
);

```

```
-- Table ELECCONDUITBANKSEGMENT
```

```

DROP TABLE "GIS"."ELECCONDUITBANKSEGMENT" cascade constraints;
CREATE TABLE "GIS"."ELECCONDUITBANKSEGMENT"
( "LABEL" VARCHAR2 (80 BYTE) ,
"DESCRIPTION" VARCHAR2 (1024 BYTE) ,
"UTILITYOWNER" VARCHAR2 (80 BYTE) ,
"ELECNETWORKTYPE" VARCHAR2 (80 BYTE) ,
"ELECSEGMENTTYPE" VARCHAR2 (80 BYTE) ,
"MATERIAL" VARCHAR2 (25 BYTE) ,
"DIAMETER" NUMBER,
"MEASUREDLENGTH" NUMBER,
"NUMBEROFCONDUITS" NUMBER,
"QUALITYLEVEL" VARCHAR2 (40 BYTE) ,
"OPERATIONALSTATUS" VARCHAR2 (17 BYTE) ,
"INVESTIGATIONLEVEL" VARCHAR2 (25 BYTE) ,
"CONFLICTID" VARCHAR2 (25 BYTE) ,
"RESOLUTION" VARCHAR2 (25 BYTE) ,
"RESOLUTIONSTATUS" VARCHAR2 (25 BYTE) ,
"DATEINSTALLED" DATE,
"DATECHANGED" DATE,
"SOURCEFILE" VARCHAR2 (60 BYTE) ,
"SITEID" NUMBER,
"OBJECTID" NUMBER,
"SEGMENTTYPE" VARCHAR2 (80 BYTE) ,
"SEGMENTSHAPETYPE" VARCHAR2 (80 BYTE) ,

```

```

"RISE" NUMBER,
"SPAN" NUMBER,
"BOTTOMWIDTH" NUMBER,
"RIGHTSIDESLOPE" NUMBER,
"LEFTSIDESLOPE" NUMBER,
"OFFSETEND" VARCHAR2(25 BYTE),
"OFFSETSTART" VARCHAR2(25 BYTE),
"STATIONEND" VARCHAR2(25 BYTE),
"STATIONSTART" VARCHAR2(25 BYTE),
"COMMENTS" VARCHAR2(1024 BYTE),
"OGC_GEOMETRY" "MDSYS"."SDO_GEOMETRY" ,
"XFM_ID" VARCHAR2(36 BYTE)
);

```

```
-- Table ELECTRICALNODE
```

```

DROP TABLE "GIS"."ELECTRICALNODE" cascade constraints;
CREATE TABLE "GIS"."ELECTRICALNODE"
( "LABEL" VARCHAR2(80 BYTE),
"DESCRIPTION" VARCHAR2(1024 BYTE),
"UTILITYOWNER" VARCHAR2(80 BYTE),
"ELECNETWORKTYPE" VARCHAR2(80 BYTE),
"ELECNODETYPE" VARCHAR2(80 BYTE),
"QUALITYLEVEL" VARCHAR2(40 BYTE),
"OPERATIONALSTATUS" VARCHAR2(17 BYTE),
"INVESTIGATIONLEVEL" VARCHAR2(25 BYTE),
"CONFLICTID" VARCHAR2(25 BYTE),
"RESOLUTION" VARCHAR2(25 BYTE),
"RESOLUTIONSTATUS" VARCHAR2(25 BYTE),
"DATEINSTALLED" DATE,
"DATECHANGED" DATE,
"SOURCEFILE" VARCHAR2(60 BYTE),
"SITEID" NUMBER,
"OBJECTID" NUMBER,
"UTILITYNODETYPE" VARCHAR2(80 BYTE),
"FITTINGTYPE" VARCHAR2(80 BYTE),
"VOLUMETYPE" VARCHAR2(80 BYTE),
"NODESHAPETYPE" VARCHAR2(80 BYTE),
"LENGTH" NUMBER,
"WIDTH" NUMBER,
"HEIGHT" NUMBER,
"ELEVATION" NUMBER,
"ELEVATIONACCURACY" NUMBER,
"BOTTOMDIAMETER" NUMBER,
"TOPDIAMETER" NUMBER,
"COMMENTS" VARCHAR2(1024 BYTE),
"OGC_GEOMETRY" "MDSYS"."SDO_GEOMETRY" ,
"XFM_ID" VARCHAR2(36 BYTE),
"MS_ANGLE" NUMBER,
"MS_X_SCALE" NUMBER,
"MS_Y_SCALE" NUMBER
);

```

```
-- Table ELECTRICALSEGMENT
```

```
DROP TABLE "GIS"."ELECTRICALSEGMENT" cascade constraints;
```

```

CREATE TABLE "GIS"."ELECTRICALSEGMENT"
( "LABEL" VARCHAR2(80 BYTE),
"DESCRIPTION" VARCHAR2(1024 BYTE),
"UTILITYOWNER" VARCHAR2(80 BYTE),
"ELECNETWORKTYPE" VARCHAR2(80 BYTE),
"ELECSEGMENTTYPE" VARCHAR2(80 BYTE),
"MATERIAL" VARCHAR2(25 BYTE),
"DIAMETER" NUMBER,
"MEASUREDLENGTH" NUMBER,
"AVERAGEWIREGAUGE" NUMBER,
"IMPEDANCE" NUMBER,
"QUALITYLEVEL" VARCHAR2(40 BYTE),
"OPERATIONALSTATUS" VARCHAR2(17 BYTE),
"INVESTIGATIONLEVEL" VARCHAR2(25 BYTE),
"CONFLICTID" VARCHAR2(25 BYTE),
"RESOLUTION" VARCHAR2(25 BYTE),
"RESOLUTIONSTATUS" VARCHAR2(25 BYTE),
"DATEINSTALLED" DATE,
"DATECHANGED" DATE,
"SOURCEFILE" VARCHAR2(60 BYTE),
"SITEID" NUMBER,
"OBJECTID" NUMBER,
"SEGMENTTYPE" VARCHAR2(80 BYTE),
"SEGMENTSHAPETYPE" VARCHAR2(80 BYTE),
"RISE" NUMBER,
"SPAN" NUMBER,
"BOTTOMWIDTH" NUMBER,
"RIGHTSIDESLOPE" NUMBER,
"LEFTSIDESLOPE" NUMBER,
"OFFSETEND" VARCHAR2(25 BYTE),
"OFFSETSTART" VARCHAR2(25 BYTE),
"STATIONEND" VARCHAR2(25 BYTE),
"STATIONSTART" VARCHAR2(25 BYTE),
"COMMENTS" VARCHAR2(1024 BYTE),
"OGC_GEOMETRY" "MDSYS"."SDO_GEOMETRY" ,
"XFM_ID" VARCHAR2(36 BYTE)
);

```

```
-- Table ELEVATIONCONTOUR
```

```

DROP TABLE "GIS"."ELEVATIONCONTOUR" cascade constraints;
CREATE TABLE "GIS"."ELEVATIONCONTOUR"
( "LABEL" VARCHAR2(80 BYTE),
"DESCRIPTION" VARCHAR2(1024 BYTE),
"UTILITYOWNER" VARCHAR2(80 BYTE),
"CONTOURELEVATION" NUMBER,
"ELEVATIONUOM" VARCHAR2(16 BYTE),
"ELEVCONTOURTYPE" VARCHAR2(13 BYTE),
"QUALITYLEVEL" VARCHAR2(40 BYTE),
"OPERATIONALSTATUS" VARCHAR2(17 BYTE),
"INVESTIGATIONLEVEL" VARCHAR2(25 BYTE),
"CONFLICTID" VARCHAR2(25 BYTE),
"RESOLUTION" VARCHAR2(25 BYTE),
"RESOLUTIONSTATUS" VARCHAR2(25 BYTE),
"DATEINSTALLED" DATE,
"DATECHANGED" DATE,

```

```
"SOURCEFILE" VARCHAR2(60 BYTE),
"SITEID" NUMBER,
"OBJECTID" NUMBER,
"COMMENTS" VARCHAR2(1024 BYTE),
"OGC_GEOMETRY" "MDSYS"."SDO_GEOMETRY" ,
"XFM_ID" VARCHAR2(36 BYTE)
);
```

```
-- Table EXTERNALPROPERTYINTEREST
```

```
DROP TABLE "GIS"."EXTERNALPROPERTYINTEREST" cascade constraints;
CREATE TABLE "GIS"."EXTERNALPROPERTYINTEREST"
( "LABEL" VARCHAR2(80 BYTE),
"DESCRIPTION" VARCHAR2(1024 BYTE),
"UTILITYOWNER" VARCHAR2(80 BYTE),
"INTERESTTYPE" VARCHAR2(15 BYTE),
"QUALITYLEVEL" VARCHAR2(40 BYTE),
"OPERATIONALSTATUS" VARCHAR2(17 BYTE),
"INVESTIGATIONLEVEL" VARCHAR2(25 BYTE),
"CONFLICTID" VARCHAR2(25 BYTE),
"RESOLUTION" VARCHAR2(25 BYTE),
"RESOLUTIONSTATUS" VARCHAR2(25 BYTE),
"DATEINSTALLED" DATE,
"DATECHANGED" DATE,
"SOURCEFILE" VARCHAR2(60 BYTE),
"SITEID" NUMBER,
"OBJECTID" NUMBER,
"COMMENTS" VARCHAR2(1024 BYTE),
"OGC_GEOMETRY" "MDSYS"."SDO_GEOMETRY" ,
"XFM_ID" VARCHAR2(36 BYTE)
);
```

```
-- Table FENCE
```

```
DROP TABLE "GIS"."FENCE" cascade constraints;
CREATE TABLE "GIS"."FENCE"
( "LABEL" VARCHAR2(80 BYTE),
"DESCRIPTION" VARCHAR2(1024 BYTE),
"UTILITYOWNER" VARCHAR2(80 BYTE),
"FENCEUSE" VARCHAR2(15 BYTE),
"QUALITYLEVEL" VARCHAR2(40 BYTE),
"OPERATIONALSTATUS" VARCHAR2(17 BYTE),
"INVESTIGATIONLEVEL" VARCHAR2(25 BYTE),
"CONFLICTID" VARCHAR2(25 BYTE),
"RESOLUTION" VARCHAR2(25 BYTE),
"RESOLUTIONSTATUS" VARCHAR2(25 BYTE),
"DATEINSTALLED" DATE,
"DATECHANGED" DATE,
"SOURCEFILE" VARCHAR2(60 BYTE),
"SITEID" NUMBER,
"OBJECTID" NUMBER,
"COMMENTS" VARCHAR2(1024 BYTE),
"OGC_GEOMETRY" "MDSYS"."SDO_GEOMETRY" ,
"XFM_ID" VARCHAR2(36 BYTE)
);
```

-- Table GASNODE

```

DROP TABLE "GIS"."GASNODE" cascade constraints;
CREATE TABLE "GIS"."GASNODE"
( "LABEL" VARCHAR2(80 BYTE),
"DESCRIPTION" VARCHAR2(1024 BYTE),
"UTILITYOWNER" VARCHAR2(80 BYTE),
"GASNETWORKTYPE" VARCHAR2(80 BYTE),
"GASNODETYPE" VARCHAR2(80 BYTE),
"QUALITYLEVEL" VARCHAR2(40 BYTE),
"OPERATIONALSTATUS" VARCHAR2(17 BYTE),
"INVESTIGATIONLEVEL" VARCHAR2(25 BYTE),
"CONFLICTID" VARCHAR2(25 BYTE),
"RESOLUTION" VARCHAR2(25 BYTE),
"RESOLUTIONSTATUS" VARCHAR2(25 BYTE),
"DATEINSTALLED" DATE,
"DATECHANGED" DATE,
"SOURCEFILE" VARCHAR2(60 BYTE),
"SITEID" NUMBER,
"OBJECTID" NUMBER,
"UTILITYNODETYPE" VARCHAR2(80 BYTE),
"FITTINGTYPE" VARCHAR2(80 BYTE),
"VOLUMETYPE" VARCHAR2(80 BYTE),
"NODESHAPETYPE" VARCHAR2(80 BYTE),
"LENGTH" NUMBER,
"WIDTH" NUMBER,
"HEIGHT" NUMBER,
"ELEVATION" NUMBER,
"ELEVATIONACCURACY" NUMBER,
"BOTTOMDIAMETER" NUMBER,
"TOPDIAMETER" NUMBER,
"COMMENTS" VARCHAR2(1024 BYTE),
"OGC_GEOMETRY" "MDSYS"."SDO_GEOMETRY" ,
"XFM_ID" VARCHAR2(36 BYTE),
"MS_ANGLE" NUMBER,
"MS_X_SCALE" NUMBER,
"MS_Y_SCALE" NUMBER
);

```

-- Table GASSEGMENT

```

DROP TABLE "GIS"."GASSEGMENT" cascade constraints;
CREATE TABLE "GIS"."GASSEGMENT"
( "LABEL" VARCHAR2(80 BYTE),
"DESCRIPTION" VARCHAR2(1024 BYTE),
"UTILITYOWNER" VARCHAR2(80 BYTE),
"GASNETWORKTYPE" VARCHAR2(80 BYTE),
"GASSEGMENTTYPE" VARCHAR2(80 BYTE),
"MATERIAL" VARCHAR2(25 BYTE),
"DIAMETER" NUMBER,
"INTERNALDIAMETER" NUMBER,
"MEASUREDLENGTH" NUMBER,
"ROUGHNESSCOEFFICIENT" NUMBER,
"QUALITYLEVEL" VARCHAR2(40 BYTE),
"OPERATIONALSTATUS" VARCHAR2(17 BYTE),
"INVESTIGATIONLEVEL" VARCHAR2(25 BYTE),

```

```

"CONFLICTID" VARCHAR2 (25 BYTE) ,
"RESOLUTION" VARCHAR2 (25 BYTE) ,
"RESOLUTIONSTATUS" VARCHAR2 (25 BYTE) ,
"DATEINSTALLED" DATE ,
"DATECHANGED" DATE ,
"SOURCEFILE" VARCHAR2 (60 BYTE) ,
"SITEID" NUMBER ,
"OBJECTID" NUMBER ,
"SEGMENTTYPE" VARCHAR2 (80 BYTE) ,
"SEGMENTSHAPETYPE" VARCHAR2 (80 BYTE) ,
"RISE" NUMBER ,
"SPAN" NUMBER ,
"BOTTOMWIDTH" NUMBER ,
"RIGHTSIDESLOPE" NUMBER ,
"LEFTSIDESLOPE" NUMBER ,
"OFFSETEND" VARCHAR2 (25 BYTE) ,
"OFFSETSTART" VARCHAR2 (25 BYTE) ,
"STATIONEND" VARCHAR2 (25 BYTE) ,
"STATIONSTART" VARCHAR2 (25 BYTE) ,
"COMMENTS" VARCHAR2 (1024 BYTE) ,
"OGC_GEOMETRY" "MDSYS"."SDO_GEOMETRY" ,
"XFM_ID" VARCHAR2 (36 BYTE)
);

```

```
-- Table GRID
```

```

DROP TABLE "GIS"."GRID" cascade constraints;
CREATE TABLE "GIS"."GRID"
( "LABEL" VARCHAR2 (80 BYTE) ,
"DESCRIPTION" VARCHAR2 (1024 BYTE) ,
"UTILITYOWNER" VARCHAR2 (80 BYTE) ,
"QUALITYLEVEL" VARCHAR2 (40 BYTE) ,
"OPERATIONALSTATUS" VARCHAR2 (17 BYTE) ,
"INVESTIGATIONLEVEL" VARCHAR2 (25 BYTE) ,
"CONFLICTID" VARCHAR2 (25 BYTE) ,
"RESOLUTION" VARCHAR2 (25 BYTE) ,
"RESOLUTIONSTATUS" VARCHAR2 (25 BYTE) ,
"DATEINSTALLED" DATE ,
"DATECHANGED" DATE ,
"SOURCEFILE" VARCHAR2 (60 BYTE) ,
"SITEID" NUMBER ,
"OBJECTID" NUMBER ,
"COMMENTS" VARCHAR2 (1024 BYTE) ,
"OGC_GEOMETRY" "MDSYS"."SDO_GEOMETRY" ,
"XFM_ID" VARCHAR2 (36 BYTE)
);

```

```
-- Table GUARDRAIL
```

```

DROP TABLE "GIS"."GUARDRAIL" cascade constraints;
CREATE TABLE "GIS"."GUARDRAIL"
( "LABEL" VARCHAR2 (80 BYTE) ,
"DESCRIPTION" VARCHAR2 (1024 BYTE) ,
"UTILITYOWNER" VARCHAR2 (80 BYTE) ,
"GUARDMATERIAL" VARCHAR2 (16 BYTE) ,
"GUARDHEIGHT" NUMBER ,

```

```

"HEIGHTUOM" VARCHAR2(16 BYTE),
"QUALITYLEVEL" VARCHAR2(40 BYTE),
"OPERATIONALSTATUS" VARCHAR2(17 BYTE),
"INVESTIGATIONLEVEL" VARCHAR2(25 BYTE),
"CONFLICTID" VARCHAR2(25 BYTE),
"RESOLUTION" VARCHAR2(25 BYTE),
"RESOLUTIONSTATUS" VARCHAR2(25 BYTE),
"DATEINSTALLED" DATE,
"DATECHANGED" DATE,
"SOURCEFILE" VARCHAR2(60 BYTE),
"SITEID" NUMBER,
"OBJECTID" NUMBER,
"COMMENTS" VARCHAR2(1024 BYTE),
"OGC_GEOMETRY" "MDSYS"."SDO_GEOMETRY" ,
"XFM_ID" VARCHAR2(36 BYTE)
);

```

```
-- Table INSTALLATION
```

```

DROP TABLE "GIS"."INSTALLATION" cascade constraints;
CREATE TABLE "GIS"."INSTALLATION"
( "LABEL" VARCHAR2(80 BYTE),
"DESCRIPTION" VARCHAR2(1024 BYTE),
"UTILITYOWNER" VARCHAR2(80 BYTE),
"DATERECORDED" DATE,
"QUALITYLEVEL" VARCHAR2(40 BYTE),
"OPERATIONALSTATUS" VARCHAR2(17 BYTE),
"INVESTIGATIONLEVEL" VARCHAR2(25 BYTE),
"CONFLICTID" VARCHAR2(25 BYTE),
"RESOLUTION" VARCHAR2(25 BYTE),
"RESOLUTIONSTATUS" VARCHAR2(25 BYTE),
"DATEINSTALLED" DATE,
"DATECHANGED" DATE,
"SOURCEFILE" VARCHAR2(60 BYTE),
"SITEID" NUMBER,
"OBJECTID" NUMBER,
"COMMENTS" VARCHAR2(1024 BYTE),
"OGC_GEOMETRY" "MDSYS"."SDO_GEOMETRY" ,
"XFM_ID" VARCHAR2(36 BYTE)
);

```

```
-- Table LANDPARCEL
```

```

DROP TABLE "GIS"."LANDPARCEL" cascade constraints;
CREATE TABLE "GIS"."LANDPARCEL"
( "LABEL" VARCHAR2(80 BYTE),
"DESCRIPTION" VARCHAR2(1024 BYTE),
"UTILITYOWNER" VARCHAR2(80 BYTE),
"QUALITYLEVEL" VARCHAR2(40 BYTE),
"OPERATIONALSTATUS" VARCHAR2(17 BYTE),
"INVESTIGATIONLEVEL" VARCHAR2(25 BYTE),
"CONFLICTID" VARCHAR2(25 BYTE),
"RESOLUTION" VARCHAR2(25 BYTE),
"RESOLUTIONSTATUS" VARCHAR2(25 BYTE),
"DATEINSTALLED" DATE,
"DATECHANGED" DATE,

```

```
"SOURCEFILE" VARCHAR2(60 BYTE),
"SITEID" NUMBER,
"OBJECTID" NUMBER,
"COMMENTS" VARCHAR2(1024 BYTE),
"OGC_GEOMETRY" "MDSYS"."SDO_GEOMETRY" ,
"XFM_ID" VARCHAR2(36 BYTE)
);
```

```
-- Table PAVEMENTSECTION
```

```
DROP TABLE "GIS"."PAVEMENTSECTION" cascade constraints;
CREATE TABLE "GIS"."PAVEMENTSECTION"
( "LABEL" VARCHAR2(80 BYTE),
"DESCRIPTION" VARCHAR2(1024 BYTE),
"UTILITYOWNER" VARCHAR2(80 BYTE),
"PAVEMENTSECTIONTYPE" VARCHAR2(16 BYTE),
"QUALITYLEVEL" VARCHAR2(40 BYTE),
"OPERATIONALSTATUS" VARCHAR2(17 BYTE),
"INVESTIGATIONLEVEL" VARCHAR2(25 BYTE),
"CONFLICTID" VARCHAR2(25 BYTE),
"RESOLUTION" VARCHAR2(25 BYTE),
"RESOLUTIONSTATUS" VARCHAR2(25 BYTE),
"DATEINSTALLED" DATE,
"DATECHANGED" DATE,
"SOURCEFILE" VARCHAR2(60 BYTE),
"SITEID" NUMBER,
"OBJECTID" NUMBER,
"COMMENTS" VARCHAR2(1024 BYTE),
"OGC_GEOMETRY" "MDSYS"."SDO_GEOMETRY" ,
"XFM_ID" VARCHAR2(36 BYTE)
);
```

```
-- Table POLNODE
```

```
DROP TABLE "GIS"."POLNODE" cascade constraints;
CREATE TABLE "GIS"."POLNODE"
( "LABEL" VARCHAR2(80 BYTE),
"DESCRIPTION" VARCHAR2(1024 BYTE),
"UTILITYOWNER" VARCHAR2(80 BYTE),
"POLNETWORKTYPE" VARCHAR2(80 BYTE),
"POLNODETYPE" VARCHAR2(80 BYTE),
"QUALITYLEVEL" VARCHAR2(40 BYTE),
"OPERATIONALSTATUS" VARCHAR2(17 BYTE),
"INVESTIGATIONLEVEL" VARCHAR2(25 BYTE),
"CONFLICTID" VARCHAR2(25 BYTE),
"RESOLUTION" VARCHAR2(25 BYTE),
"RESOLUTIONSTATUS" VARCHAR2(25 BYTE),
"DATEINSTALLED" DATE,
"DATECHANGED" DATE,
"SOURCEFILE" VARCHAR2(60 BYTE),
"SITEID" NUMBER,
"OBJECTID" NUMBER,
"UTILITYNODETYPE" VARCHAR2(80 BYTE),
"FITTINGTYPE" VARCHAR2(80 BYTE),
"VOLUMETYPE" VARCHAR2(80 BYTE),
"NODESHAPETYPE" VARCHAR2(80 BYTE),
```



```

"LENGTH" NUMBER,
"WIDTH" NUMBER,
"HEIGHT" NUMBER,
"ELEVATION" NUMBER,
"ELEVATIONACCURACY" NUMBER,
"BOTTOMDIAMETER" NUMBER,
"TOPDIAMETER" NUMBER,
"COMMENTS" VARCHAR2(1024 BYTE),
"OGC_GEOMETRY" "MDSYS"."SDO_GEOMETRY" ,
"XFM_ID" VARCHAR2(36 BYTE),
"MS_ANGLE" NUMBER,
"MS_X_SCALE" NUMBER,
"MS_Y_SCALE" NUMBER
);

```

```
-- Table POLSEGMENT
```

```

DROP TABLE "GIS"."POLSEGMENT" cascade constraints;
CREATE TABLE "GIS"."POLSEGMENT"
( "LABEL" VARCHAR2(80 BYTE),
"DESCRIPTION" VARCHAR2(1024 BYTE),
"UTILITYOWNER" VARCHAR2(80 BYTE),
"POLNETWORKTYPE" VARCHAR2(80 BYTE),
"POLSEGMENTTYPE" VARCHAR2(80 BYTE),
"MATERIAL" VARCHAR2(25 BYTE),
"DIAMETER" NUMBER,
"INTERNALDIAMETER" NUMBER,
"MEASUREDLENGTH" NUMBER,
"ROUGHNESSCOEFFICIENT" NUMBER,
"QUALITYLEVEL" VARCHAR2(40 BYTE),
"OPERATIONALSTATUS" VARCHAR2(17 BYTE),
"INVESTIGATIONLEVEL" VARCHAR2(25 BYTE),
"CONFLICTID" VARCHAR2(25 BYTE),
"RESOLUTION" VARCHAR2(25 BYTE),
"RESOLUTIONSTATUS" VARCHAR2(25 BYTE),
"DATEINSTALLED" DATE,
"DATECHANGED" DATE,
"SOURCEFILE" VARCHAR2(60 BYTE),
"SITEID" NUMBER,
"OBJECTID" NUMBER,
"SEGMENTTYPE" VARCHAR2(80 BYTE),
"SEGMENTSHAPETYPE" VARCHAR2(80 BYTE),
"RISE" NUMBER,
"SPAN" NUMBER,
"BOTTOMWIDTH" NUMBER,
"RIGHTSIDESLOPE" NUMBER,
"LEFTSIDESLOPE" NUMBER,
"OFFSETEND" VARCHAR2(25 BYTE),
"OFFSETSTART" VARCHAR2(25 BYTE),
"STATIONEND" VARCHAR2(25 BYTE),
"STATIONSTART" VARCHAR2(25 BYTE),
"COMMENTS" VARCHAR2(1024 BYTE),
"OGC_GEOMETRY" "MDSYS"."SDO_GEOMETRY" ,
"XFM_ID" VARCHAR2(36 BYTE)
);

```

-- Table PROJECTREFERENCE

```

DROP TABLE "GIS"."PROJECTREFERENCE" cascade constraints;
CREATE TABLE "GIS"."PROJECTREFERENCE"
( "LABEL" VARCHAR2(80 BYTE),
"DESCRIPTION" VARCHAR2(1024 BYTE),
"UTILITYOWNER" VARCHAR2(80 BYTE),
"PROJECTID" VARCHAR2(30 BYTE),
"QUALITYLEVEL" VARCHAR2(40 BYTE),
"OPERATIONALSTATUS" VARCHAR2(17 BYTE),
"INVESTIGATIONLEVEL" VARCHAR2(25 BYTE),
"CONFLICTID" VARCHAR2(25 BYTE),
"RESOLUTION" VARCHAR2(25 BYTE),
"RESOLUTIONSTATUS" VARCHAR2(25 BYTE),
"DATEINSTALLED" DATE,
"DATECHANGED" DATE,
"SOURCEFILE" VARCHAR2(60 BYTE),
"SITEID" NUMBER,
"OBJECTID" NUMBER,
"COMMENTS" VARCHAR2(1024 BYTE),
"OGC_GEOMETRY" "MDSYS"."SDO_GEOMETRY" ,
"XFM_ID" VARCHAR2(36 BYTE)
);

```

-- Table RAILTRACK

```

DROP TABLE "GIS"."RAILTRACK" cascade constraints;
CREATE TABLE "GIS"."RAILTRACK"
( "LABEL" VARCHAR2(80 BYTE),
"DESCRIPTION" VARCHAR2(1024 BYTE),
"UTILITYOWNER" VARCHAR2(80 BYTE),
"RAILCONSTRUCTIONTYPE" VARCHAR2(15 BYTE),
"QUALITYLEVEL" VARCHAR2(40 BYTE),
"OPERATIONALSTATUS" VARCHAR2(17 BYTE),
"INVESTIGATIONLEVEL" VARCHAR2(25 BYTE),
"CONFLICTID" VARCHAR2(25 BYTE),
"RESOLUTION" VARCHAR2(25 BYTE),
"RESOLUTIONSTATUS" VARCHAR2(25 BYTE),
"DATEINSTALLED" DATE,
"DATECHANGED" DATE,
"SOURCEFILE" VARCHAR2(60 BYTE),
"SITEID" NUMBER,
"OBJECTID" NUMBER,
"COMMENTS" VARCHAR2(1024 BYTE),
"OGC_GEOMETRY" "MDSYS"."SDO_GEOMETRY" ,
"XFM_ID" VARCHAR2(36 BYTE)
);

```

-- Table RECREATIONAREA

```

DROP TABLE "GIS"."RECREATIONAREA" cascade constraints;
CREATE TABLE "GIS"."RECREATIONAREA"
( "LABEL" VARCHAR2(80 BYTE),
"DESCRIPTION" VARCHAR2(1024 BYTE),
"UTILITYOWNER" VARCHAR2(80 BYTE),
"AREATYPE" VARCHAR2(22 BYTE),

```

```

"QUALITYLEVEL" VARCHAR2(40 BYTE),
"OPERATIONALSTATUS" VARCHAR2(17 BYTE),
"INVESTIGATIONLEVEL" VARCHAR2(25 BYTE),
"CONFLICTID" VARCHAR2(25 BYTE),
"RESOLUTION" VARCHAR2(25 BYTE),
"RESOLUTIONSTATUS" VARCHAR2(25 BYTE),
"DATEINSTALLED" DATE,
"DATECHANGED" DATE,
"SOURCEFILE" VARCHAR2(60 BYTE),
"SITEID" NUMBER,
"OBJECTID" NUMBER,
"COMMENTS" VARCHAR2(1024 BYTE),
"OGC_GEOMETRY" "MDSYS"."SDO_GEOMETRY" ,
"XFM_ID" VARCHAR2(36 BYTE)
);

```

```
-- Table RECREATIONFEATURE
```

```

DROP TABLE "GIS"."RECREATIONFEATURE" cascade constraints;
CREATE TABLE "GIS"."RECREATIONFEATURE"
( "LABEL" VARCHAR2(80 BYTE),
"DESCRIPTION" VARCHAR2(1024 BYTE),
"UTILITYOWNER" VARCHAR2(80 BYTE),
"QUALITYLEVEL" VARCHAR2(40 BYTE),
"OPERATIONALSTATUS" VARCHAR2(17 BYTE),
"INVESTIGATIONLEVEL" VARCHAR2(25 BYTE),
"CONFLICTID" VARCHAR2(25 BYTE),
"RESOLUTION" VARCHAR2(25 BYTE),
"RESOLUTIONSTATUS" VARCHAR2(25 BYTE),
"DATEINSTALLED" DATE,
"DATECHANGED" DATE,
"SOURCEFILE" VARCHAR2(60 BYTE),
"SITEID" NUMBER,
"OBJECTID" NUMBER,
"COMMENTS" VARCHAR2(1024 BYTE),
"OGC_GEOMETRY" "MDSYS"."SDO_GEOMETRY" ,
"XFM_ID" VARCHAR2(36 BYTE),
"MS_ANGLE" NUMBER,
"MS_X_SCALE" NUMBER,
"MS_Y_SCALE" NUMBER
);

```

```
-- Table RESTRICTEDAREA
```

```

DROP TABLE "GIS"."RESTRICTEDAREA" cascade constraints;
CREATE TABLE "GIS"."RESTRICTEDAREA"
( "LABEL" VARCHAR2(80 BYTE),
"DESCRIPTION" VARCHAR2(1024 BYTE),
"UTILITYOWNER" VARCHAR2(80 BYTE),
"RESTRICTIONDESCRIPTION" VARCHAR2(1024 BYTE),
"QUALITYLEVEL" VARCHAR2(40 BYTE),
"OPERATIONALSTATUS" VARCHAR2(17 BYTE),
"INVESTIGATIONLEVEL" VARCHAR2(25 BYTE),
"CONFLICTID" VARCHAR2(25 BYTE),
"RESOLUTION" VARCHAR2(25 BYTE),
"RESOLUTIONSTATUS" VARCHAR2(25 BYTE),
);

```

```

"DATEINSTALLED" DATE,
"DATECHANGED" DATE,
"SOURCEFILE" VARCHAR2(60 BYTE),
"SITEID" NUMBER,
"OBJECTID" NUMBER,
"COMMENTS" VARCHAR2(1024 BYTE),
"OGC_GEOMETRY" "MDSYS"."SDO_GEOMETRY" ,
"XFM_ID" VARCHAR2(36 BYTE)
);

```

```
-- Table ROADPATH
```

```

DROP TABLE "GIS"."ROADPATH" cascade constraints;
CREATE TABLE "GIS"."ROADPATH"
( "LABEL" VARCHAR2(80 BYTE),
"DESCRIPTION" VARCHAR2(1024 BYTE),
"UTILITYOWNER" VARCHAR2(80 BYTE),
"ROUTENAME" VARCHAR2(30 BYTE),
"QUALITYLEVEL" VARCHAR2(40 BYTE),
"OPERATIONALSTATUS" VARCHAR2(17 BYTE),
"INVESTIGATIONLEVEL" VARCHAR2(25 BYTE),
"CONFLICTID" VARCHAR2(25 BYTE),
"RESOLUTION" VARCHAR2(25 BYTE),
"RESOLUTIONSTATUS" VARCHAR2(25 BYTE),
"DATEINSTALLED" DATE,
"DATECHANGED" DATE,
"SOURCEFILE" VARCHAR2(60 BYTE),
"SITEID" NUMBER,
"OBJECTID" NUMBER,
"COMMENTS" VARCHAR2(1024 BYTE),
"OGC_GEOMETRY" "MDSYS"."SDO_GEOMETRY" ,
"XFM_ID" VARCHAR2(36 BYTE)
);

```

```
-- Table SIGN
```

```

DROP TABLE "GIS"."SIGN" cascade constraints;
CREATE TABLE "GIS"."SIGN"
( "LABEL" VARCHAR2(80 BYTE),
"DESCRIPTION" VARCHAR2(1024 BYTE),
"UTILITYOWNER" VARCHAR2(80 BYTE),
"SIGNTYPE" VARCHAR2(14 BYTE),
"QUALITYLEVEL" VARCHAR2(40 BYTE),
"OPERATIONALSTATUS" VARCHAR2(17 BYTE),
"INVESTIGATIONLEVEL" VARCHAR2(25 BYTE),
"CONFLICTID" VARCHAR2(25 BYTE),
"RESOLUTION" VARCHAR2(25 BYTE),
"RESOLUTIONSTATUS" VARCHAR2(25 BYTE),
"DATEINSTALLED" DATE,
"DATECHANGED" DATE,
"SOURCEFILE" VARCHAR2(60 BYTE),
"SITEID" NUMBER,
"OBJECTID" NUMBER,
"COMMENTS" VARCHAR2(1024 BYTE),
"OGC_GEOMETRY" "MDSYS"."SDO_GEOMETRY" ,
"XFM_ID" VARCHAR2(36 BYTE),

```

```
"MS_ANGLE" NUMBER,
"MS_X_SCALE" NUMBER,
"MS_Y_SCALE" NUMBER
);
```

```
-- Table SITE
```

```
DROP TABLE "GIS"."SITE" cascade constraints;
CREATE TABLE "GIS"."SITE"
( "LABEL" VARCHAR2(80 BYTE),
"DESCRIPTION" VARCHAR2(1024 BYTE),
"UTILITYOWNER" VARCHAR2(80 BYTE),
"QUALITYLEVEL" VARCHAR2(40 BYTE),
"OPERATIONALSTATUS" VARCHAR2(17 BYTE),
"INVESTIGATIONLEVEL" VARCHAR2(25 BYTE),
"CONFLICTID" VARCHAR2(25 BYTE),
"RESOLUTION" VARCHAR2(25 BYTE),
"RESOLUTIONSTATUS" VARCHAR2(25 BYTE),
"DATEINSTALLED" DATE,
"DATECHANGED" DATE,
"SOURCEFILE" VARCHAR2(60 BYTE),
"SITEID" NUMBER,
"OBJECTID" NUMBER,
"COMMENTS" VARCHAR2(1024 BYTE),
"OGC_GEOMETRY" "MDSYS"."SDO_GEOMETRY" ,
"XFM_ID" VARCHAR2(36 BYTE)
);
```

```
-- Table STRUCTURE
```

```
DROP TABLE "GIS"."STRUCTURE" cascade constraints;
CREATE TABLE "GIS"."STRUCTURE"
( "LABEL" VARCHAR2(80 BYTE),
"DESCRIPTION" VARCHAR2(1024 BYTE),
"UTILITYOWNER" VARCHAR2(80 BYTE),
"QUALITYLEVEL" VARCHAR2(40 BYTE),
"OPERATIONALSTATUS" VARCHAR2(17 BYTE),
"INVESTIGATIONLEVEL" VARCHAR2(25 BYTE),
"CONFLICTID" VARCHAR2(25 BYTE),
"RESOLUTION" VARCHAR2(25 BYTE),
"RESOLUTIONSTATUS" VARCHAR2(25 BYTE),
"DATEINSTALLED" DATE,
"DATECHANGED" DATE,
"SOURCEFILE" VARCHAR2(60 BYTE),
"SITEID" NUMBER,
"OBJECTID" NUMBER,
"COMMENTS" VARCHAR2(1024 BYTE),
"OGC_GEOMETRY" "MDSYS"."SDO_GEOMETRY" ,
"XFM_ID" VARCHAR2(36 BYTE)
);
```

```
-- Table SURVEYJOB
```

```
DROP TABLE "GIS"."SURVEYJOB" cascade constraints;
CREATE TABLE "GIS"."SURVEYJOB"
( "LABEL" VARCHAR2(80 BYTE),
```

```

"DESCRIPTION" VARCHAR2(1024 BYTE),
"UTILITYOWNER" VARCHAR2(80 BYTE),
"SURVEYTYPE" VARCHAR2(26 BYTE),
"SURVEYMETHOD" VARCHAR2(26 BYTE),
"QUALITYLEVEL" VARCHAR2(40 BYTE),
"OPERATIONALSTATUS" VARCHAR2(17 BYTE),
"INVESTIGATIONLEVEL" VARCHAR2(25 BYTE),
"CONFLICTID" VARCHAR2(25 BYTE),
"RESOLUTION" VARCHAR2(25 BYTE),
"RESOLUTIONSTATUS" VARCHAR2(25 BYTE),
"DATEINSTALLED" DATE,
"DATECHANGED" DATE,
"SOURCEFILE" VARCHAR2(60 BYTE),
"SITEID" NUMBER,
"OBJECTID" NUMBER,
"COMMENTS" VARCHAR2(1024 BYTE),
"OGC_GEOMETRY" "MDSYS"."SDO_GEOMETRY" ,
"XFM_ID" VARCHAR2(36 BYTE)
);

```

```
-- Table SURVEYPOINT
```

```

DROP TABLE "GIS"."SURVEYPOINT" cascade constraints;
CREATE TABLE "GIS"."SURVEYPOINT"
( "LABEL" VARCHAR2(80 BYTE),
"DESCRIPTION" VARCHAR2(1024 BYTE),
"UTILITYOWNER" VARCHAR2(80 BYTE),
"SOURCETYPE" VARCHAR2(15 BYTE),
"QUALITYLEVEL" VARCHAR2(40 BYTE),
"OPERATIONALSTATUS" VARCHAR2(17 BYTE),
"INVESTIGATIONLEVEL" VARCHAR2(25 BYTE),
"CONFLICTID" VARCHAR2(25 BYTE),
"RESOLUTION" VARCHAR2(25 BYTE),
"RESOLUTIONSTATUS" VARCHAR2(25 BYTE),
"DATEINSTALLED" DATE,
"DATECHANGED" DATE,
"SOURCEFILE" VARCHAR2(60 BYTE),
"SITEID" NUMBER,
"OBJECTID" NUMBER,
"COMMENTS" VARCHAR2(1024 BYTE),
"OGC_GEOMETRY" "MDSYS"."SDO_GEOMETRY" ,
"XFM_ID" VARCHAR2(36 BYTE),
"MS_ANGLE" NUMBER,
"MS_X_SCALE" NUMBER,
"MS_Y_SCALE" NUMBER
);

```

```
-- Table THERMALNODE
```

```

DROP TABLE "GIS"."THERMALNODE" cascade constraints;
CREATE TABLE "GIS"."THERMALNODE"
( "LABEL" VARCHAR2(80 BYTE),
"DESCRIPTION" VARCHAR2(1024 BYTE),
"UTILITYOWNER" VARCHAR2(80 BYTE),
"THERMNETWORKTYPE" VARCHAR2(80 BYTE),
"THERMNODETYPE" VARCHAR2(80 BYTE),

```

```

"QUALITYLEVEL" VARCHAR2 (40 BYTE) ,
"OPERATIONALSTATUS" VARCHAR2 (17 BYTE) ,
"INVESTIGATIONLEVEL" VARCHAR2 (25 BYTE) ,
"CONFLICTID" VARCHAR2 (25 BYTE) ,
"RESOLUTION" VARCHAR2 (25 BYTE) ,
"RESOLUTIONSTATUS" VARCHAR2 (25 BYTE) ,
"DATEINSTALLED" DATE ,
"DATECHANGED" DATE ,
"SOURCEFILE" VARCHAR2 (60 BYTE) ,
"SITEID" NUMBER ,
"OBJECTID" NUMBER ,
"UTILITYNODETYPE" VARCHAR2 (80 BYTE) ,
"FITTINGTYPE" VARCHAR2 (80 BYTE) ,
"VOLUMETYPE" VARCHAR2 (80 BYTE) ,
"NODESHAPETYPE" VARCHAR2 (80 BYTE) ,
"LENGTH" NUMBER ,
"WIDTH" NUMBER ,
"HEIGHT" NUMBER ,
"ELEVATION" NUMBER ,
"ELEVATIONACCURACY" NUMBER ,
"BOTTOMDIAMETER" NUMBER ,
"TOPDIAMETER" NUMBER ,
"COMMENTS" VARCHAR2 (1024 BYTE) ,
"OGC_GEOMETRY" "MDSYS"."SDO_GEOMETRY" ,
"XFM_ID" VARCHAR2 (36 BYTE) ,
"MS_ANGLE" NUMBER ,
"MS_X_SCALE" NUMBER ,
"MS_Y_SCALE" NUMBER
);

```

```
-- Table THERMALSEGMENT
```

```

DROP TABLE "GIS"."THERMALSEGMENT" cascade constraints;
CREATE TABLE "GIS"."THERMALSEGMENT"
( "LABEL" VARCHAR2 (80 BYTE) ,
"DESCRIPTION" VARCHAR2 (1024 BYTE) ,
"UTILITYOWNER" VARCHAR2 (80 BYTE) ,
"THERMNETWORKTYPE" VARCHAR2 (80 BYTE) ,
"THERMSEGMENTTYPE" VARCHAR2 (80 BYTE) ,
"MATERIAL" VARCHAR2 (25 BYTE) ,
"DIAMETER" NUMBER ,
"INTERNALDIAMETER" NUMBER ,
"MEASUREDLENGTH" NUMBER ,
"ROUGHNESSCOEFFICIENT" NUMBER ,
"QUALITYLEVEL" VARCHAR2 (40 BYTE) ,
"OPERATIONALSTATUS" VARCHAR2 (17 BYTE) ,
"INVESTIGATIONLEVEL" VARCHAR2 (25 BYTE) ,
"CONFLICTID" VARCHAR2 (25 BYTE) ,
"RESOLUTION" VARCHAR2 (25 BYTE) ,
"RESOLUTIONSTATUS" VARCHAR2 (25 BYTE) ,
"DATEINSTALLED" DATE ,
"DATECHANGED" DATE ,
"SOURCEFILE" VARCHAR2 (60 BYTE) ,
"SITEID" NUMBER ,
"OBJECTID" NUMBER ,
"SEGMENTTYPE" VARCHAR2 (80 BYTE) ,

```

```

"SEGMENTSHAPETYPE" VARCHAR2(80 BYTE),
"RISE" NUMBER,
"SPAN" NUMBER,
"BOTTOMWIDTH" NUMBER,
"RIGHTSIDESLOPE" NUMBER,
"LEFTSIDESLOPE" NUMBER,
"OFFSETEND" VARCHAR2(25 BYTE),
"OFFSETSTART" VARCHAR2(25 BYTE),
"STATIONEND" VARCHAR2(25 BYTE),
"STATIONSTART" VARCHAR2(25 BYTE),
"COMMENTS" VARCHAR2(1024 BYTE),
"OGC_GEOMETRY" "MDSYS"."SDO_GEOMETRY" ,
"XFM_ID" VARCHAR2(36 BYTE)
);

```

```
-- Table TOWER
```

```

DROP TABLE "GIS"."TOWER" cascade constraints;
CREATE TABLE "GIS"."TOWER"
( "LABEL" VARCHAR2(80 BYTE),
"DESCRIPTION" VARCHAR2(1024 BYTE),
"UTILITYOWNER" VARCHAR2(80 BYTE),
"FACILITYNAME" VARCHAR2(65 BYTE),
"HEIGHTMAX" NUMBER,
"HEIGHTUOM" VARCHAR2(16 BYTE),
"TOWERCONDITION" VARCHAR2(14 BYTE),
"TOWERMATERIAL" VARCHAR2(16 BYTE),
"TOWERUSETYPE" VARCHAR2(14 BYTE),
"QUALITYLEVEL" VARCHAR2(40 BYTE),
"OPERATIONALSTATUS" VARCHAR2(17 BYTE),
"INVESTIGATIONLEVEL" VARCHAR2(25 BYTE),
"CONFLICTID" VARCHAR2(25 BYTE),
"RESOLUTION" VARCHAR2(25 BYTE),
"RESOLUTIONSTATUS" VARCHAR2(25 BYTE),
"DATEINSTALLED" DATE,
"DATECHANGED" DATE,
"SOURCEFILE" VARCHAR2(60 BYTE),
"SITEID" NUMBER,
"OBJECTID" NUMBER,
"COMMENTS" VARCHAR2(1024 BYTE),
"OGC_GEOMETRY" "MDSYS"."SDO_GEOMETRY" ,
"XFM_ID" VARCHAR2(36 BYTE),
"MS_ANGLE" NUMBER,
"MS_X_SCALE" NUMBER,
"MS_Y_SCALE" NUMBER
);

```

```
-- Table TRANSPORTATIONTUNNEL
```

```

DROP TABLE "GIS"."TRANSPORTATIONTUNNEL" cascade constraints;
CREATE TABLE "GIS"."TRANSPORTATIONTUNNEL"
( "LABEL" VARCHAR2(80 BYTE),
"DESCRIPTION" VARCHAR2(1024 BYTE),
"UTILITYOWNER" VARCHAR2(80 BYTE),
"AVERAGEHEIGHT" NUMBER,
"AVERAGEWIDTH" NUMBER,

```



```

"NAICSCODE" NUMBER,
"TUNNELLENGTH" NUMBER,
"TUNNELTYPE" VARCHAR2(8 BYTE),
"VERTICLEARANCE" NUMBER,
"QUALITYLEVEL" VARCHAR2(40 BYTE),
"OPERATIONALSTATUS" VARCHAR2(17 BYTE),
"INVESTIGATIONLEVEL" VARCHAR2(25 BYTE),
"CONFLICTID" VARCHAR2(25 BYTE),
"RESOLUTION" VARCHAR2(25 BYTE),
"RESOLUTIONSTATUS" VARCHAR2(25 BYTE),
"DATEINSTALLED" DATE,
"DATECHANGED" DATE,
"SOURCEFILE" VARCHAR2(60 BYTE),
"SITEID" NUMBER,
"OBJECTID" NUMBER,
"COMMENTS" VARCHAR2(1024 BYTE),
"OGC_GEOMETRY" "MDSYS"."SDO_GEOMETRY" ,
"XFM_ID" VARCHAR2(36 BYTE)
);

```

```
-- Table UTILITYFEATURE
```

```

DROP TABLE "GIS"."UTILITYFEATURE" cascade constraints;
CREATE TABLE "GIS"."UTILITYFEATURE"
( "LABEL" VARCHAR2(80 BYTE),
"DESCRIPTION" VARCHAR2(1024 BYTE),
"UTILITYOWNER" VARCHAR2(80 BYTE),
"NETWORKTYPE" VARCHAR2(14 BYTE),
"NETWORKSUBTYPE" VARCHAR2(29 BYTE),
"UTILITYFEATURETYPE" VARCHAR2(27 BYTE),
"QUALITYLEVEL" VARCHAR2(40 BYTE),
"OPERATIONALSTATUS" VARCHAR2(17 BYTE),
"INVESTIGATIONLEVEL" VARCHAR2(25 BYTE),
"CONFLICTID" VARCHAR2(25 BYTE),
"RESOLUTION" VARCHAR2(25 BYTE),
"RESOLUTIONSTATUS" VARCHAR2(25 BYTE),
"DATEINSTALLED" DATE,
"DATECHANGED" DATE,
"SOURCEFILE" VARCHAR2(60 BYTE),
"SITEID" NUMBER,
"OBJECTID" NUMBER,
"COMMENTS" VARCHAR2(1024 BYTE),
"OGC_GEOMETRY" "MDSYS"."SDO_GEOMETRY" ,
"XFM_ID" VARCHAR2(36 BYTE)
);

```

```
-- Table WALL
```

```

DROP TABLE "GIS"."WALL" cascade constraints;
CREATE TABLE "GIS"."WALL"
( "LABEL" VARCHAR2(80 BYTE),
"DESCRIPTION" VARCHAR2(1024 BYTE),
"UTILITYOWNER" VARCHAR2(80 BYTE),
"WALLHEIGHT" NUMBER,
"WALLHEIGHTUOM" VARCHAR2(16 BYTE),
"WALLTYPE" VARCHAR2(8 BYTE),

```

```

"QUALITYLEVEL" VARCHAR2(40 BYTE),
"OPERATIONALSTATUS" VARCHAR2(17 BYTE),
"INVESTIGATIONLEVEL" VARCHAR2(25 BYTE),
"CONFLICTID" VARCHAR2(25 BYTE),
"RESOLUTION" VARCHAR2(25 BYTE),
"RESOLUTIONSTATUS" VARCHAR2(25 BYTE),
"DATEINSTALLED" DATE,
"DATECHANGED" DATE,
"SOURCEFILE" VARCHAR2(60 BYTE),
"SITEID" NUMBER,
"OBJECTID" NUMBER,
"COMMENTS" VARCHAR2(1024 BYTE),
"OGC_GEOMETRY" "MDSYS"."SDO_GEOMETRY" ,
"XFM_ID" VARCHAR2(36 BYTE)
);

```

```
-- Table WASTEWATERNODE
```

```

DROP TABLE "GIS"."WASTEWATERNODE" cascade constraints;
CREATE TABLE "GIS"."WASTEWATERNODE"
( "LABEL" VARCHAR2(80 BYTE),
"DESCRIPTION" VARCHAR2(1024 BYTE),
"UTILITYOWNER" VARCHAR2(80 BYTE),
"WWATERNETWORKTYPE" VARCHAR2(80 BYTE),
"WWATERNODETYPE" VARCHAR2(80 BYTE),
"QUALITYLEVEL" VARCHAR2(40 BYTE),
"OPERATIONALSTATUS" VARCHAR2(17 BYTE),
"INVESTIGATIONLEVEL" VARCHAR2(25 BYTE),
"CONFLICTID" VARCHAR2(25 BYTE),
"RESOLUTION" VARCHAR2(25 BYTE),
"RESOLUTIONSTATUS" VARCHAR2(25 BYTE),
"DATEINSTALLED" DATE,
"DATECHANGED" DATE,
"SOURCEFILE" VARCHAR2(60 BYTE),
"SITEID" NUMBER,
"OBJECTID" NUMBER,
"UTILITYNODETYPE" VARCHAR2(80 BYTE),
"FITTINGTYPE" VARCHAR2(80 BYTE),
"VOLUMETYPE" VARCHAR2(80 BYTE),
"NODESHAPETYPE" VARCHAR2(80 BYTE),
"LENGTH" NUMBER,
"WIDTH" NUMBER,
"HEIGHT" NUMBER,
"ELEVATION" NUMBER,
"ELEVATIONACCURACY" NUMBER,
"BOTTOMWIDTH" NUMBER,
"TOPDIAMETER" NUMBER,
"COMMENTS" VARCHAR2(1024 BYTE),
"OGC_GEOMETRY" "MDSYS"."SDO_GEOMETRY" ,
"XFM_ID" VARCHAR2(36 BYTE),
"MS_ANGLE" NUMBER,
"MS_X_SCALE" NUMBER,
"MS_Y_SCALE" NUMBER
);

```

```
-- Table WASTEWATERSEGMENT
```

```

-----
DROP TABLE "GIS"."WASTEWATERSEGMENT" cascade constraints;
CREATE TABLE "GIS"."WASTEWATERSEGMENT"
( "LABEL" VARCHAR2(80 BYTE),
"DESCRIPTION" VARCHAR2(1024 BYTE),
"UTILITYOWNER" VARCHAR2(80 BYTE),
"WWATERNETWORKTYPE" VARCHAR2(80 BYTE),
"WWATERSEGMENTTYPE" VARCHAR2(80 BYTE),
"MATERIAL" VARCHAR2(25 BYTE),
"DIAMETER" NUMBER,
"INTERNALDIAMETER" NUMBER,
"MEASUREDLENGTH" NUMBER,
"ROUGHNESSCOEFFICIENT" NUMBER,
"QUALITYLEVEL" VARCHAR2(40 BYTE),
"OPERATIONALSTATUS" VARCHAR2(17 BYTE),
"INVESTIGATIONLEVEL" VARCHAR2(25 BYTE),
"CONFLICTID" VARCHAR2(25 BYTE),
"RESOLUTION" VARCHAR2(25 BYTE),
"RESOLUTIONSTATUS" VARCHAR2(25 BYTE),
"DATEINSTALLED" DATE,
"DATECHANGED" DATE,
"SOURCEFILE" VARCHAR2(60 BYTE),
"SITEID" NUMBER,
"OBJECTID" NUMBER,
"COMMENTS" VARCHAR2(1024 BYTE),
"OGC_GEOMETRY" "MDSYS"."SDO_GEOMETRY" ,
"XFM_ID" VARCHAR2(36 BYTE)
);

```

```

-----
-- Table WATERCOURSELINE
-----

```

```

DROP TABLE "GIS"."WATERCOURSELINE" cascade constraints;
CREATE TABLE "GIS"."WATERCOURSELINE"
( "LABEL" VARCHAR2(80 BYTE),
"DESCRIPTION" VARCHAR2(1024 BYTE),
"UTILITYOWNER" VARCHAR2(80 BYTE),
"WATERCOURSEELEMENT" VARCHAR2(19 BYTE),
"HYDROCODE" VARCHAR2(30 BYTE),
"ISNAVIGABLE" VARCHAR2(5 BYTE),
"QUALITYLEVEL" VARCHAR2(40 BYTE),
"OPERATIONALSTATUS" VARCHAR2(17 BYTE),
"INVESTIGATIONLEVEL" VARCHAR2(25 BYTE),
"CONFLICTID" VARCHAR2(25 BYTE),
"RESOLUTION" VARCHAR2(25 BYTE),
"RESOLUTIONSTATUS" VARCHAR2(25 BYTE),
"DATEINSTALLED" DATE,
"DATECHANGED" DATE,
"SOURCEFILE" VARCHAR2(60 BYTE),
"SITEID" NUMBER,
"OBJECTID" NUMBER,
"COMMENTS" VARCHAR2(1024 BYTE),
"OGC_GEOMETRY" "MDSYS"."SDO_GEOMETRY" ,
"XFM_ID" VARCHAR2(36 BYTE)
);

```

```

-----
-- Table WATERFEATURE
-----

```

```

DROP TABLE "GIS"."WATERFEATURE" cascade constraints;
CREATE TABLE "GIS"."WATERFEATURE"
( "LABEL" VARCHAR2(80 BYTE),
"DESCRIPTION" VARCHAR2(1024 BYTE),
"UTILITYOWNER" VARCHAR2(80 BYTE),
"WATERNETWORKTYPE" VARCHAR2(80 BYTE),
"WATERNODETYPE" VARCHAR2(80 BYTE),
"QUALITYLEVEL" VARCHAR2(40 BYTE),
"OPERATIONALSTATUS" VARCHAR2(17 BYTE),
"INVESTIGATIONLEVEL" VARCHAR2(25 BYTE),
"CONFLICTID" VARCHAR2(25 BYTE),
"RESOLUTION" VARCHAR2(25 BYTE),
"RESOLUTIONSTATUS" VARCHAR2(25 BYTE),
"DATEINSTALLED" DATE,
"DATECHANGED" DATE,
"SOURCEFILE" VARCHAR2(60 BYTE),
"SITEID" NUMBER,
"OBJECTID" NUMBER,
"COMMENTS" VARCHAR2(1024 BYTE),
"OGC_GEOMETRY" "MDSYS"."SDO_GEOMETRY" ,
"XFM_ID" VARCHAR2(36 BYTE)
);

```

```
-- Table WATERNODE
```

```

DROP TABLE "GIS"."WATERNODE" cascade constraints;
CREATE TABLE "GIS"."WATERNODE"
( "LABEL" VARCHAR2(80 BYTE),
"DESCRIPTION" VARCHAR2(1024 BYTE),
"UTILITYOWNER" VARCHAR2(80 BYTE),
"WATERNETWORKTYPE" VARCHAR2(80 BYTE),
"WATERNODETYPE" VARCHAR2(80 BYTE),
"QUALITYLEVEL" VARCHAR2(40 BYTE),
"OPERATIONALSTATUS" VARCHAR2(17 BYTE),
"INVESTIGATIONLEVEL" VARCHAR2(25 BYTE),
"CONFLICTID" VARCHAR2(25 BYTE),
"RESOLUTION" VARCHAR2(25 BYTE),
"RESOLUTIONSTATUS" VARCHAR2(25 BYTE),
"DATEINSTALLED" DATE,
"DATECHANGED" DATE,
"SOURCEFILE" VARCHAR2(60 BYTE),
"SITEID" NUMBER,
"OBJECTID" NUMBER,
"UTILITYNODETYPE" VARCHAR2(80 BYTE),
"FITTINGTYPE" VARCHAR2(80 BYTE),
"VOLUMETYPE" VARCHAR2(80 BYTE),
"NODESHAPETYPE" VARCHAR2(80 BYTE),
"LENGTH" NUMBER,
"WIDTH" NUMBER,
"HEIGHT" NUMBER,
"ELEVATION" NUMBER,
"ELEVATIONACCURACY" NUMBER,
"BOTTOMDIAMETER" NUMBER,
"TOPDIAMETER" NUMBER,
"COMMENTS" VARCHAR2(1024 BYTE),

```

```

"OGC_GEOMETRY" "MDSYS"."SDO_GEOMETRY" ,
"XFM_ID" VARCHAR2(36 BYTE) ,
"MS_ANGLE" NUMBER,
"MS_X_SCALE" NUMBER,
"MS_Y_SCALE" NUMBER
);

```

```
-- Table WATERSEGMENT
```

```

DROP TABLE "GIS"."WATERSEGMENT" cascade constraints;
CREATE TABLE "GIS"."WATERSEGMENT"
( "LABEL" VARCHAR2(80 BYTE) ,
  "DESCRIPTION" VARCHAR2(1024 BYTE) ,
  "UTILITYOWNER" VARCHAR2(80 BYTE) ,
  "WATERSEGMENTTYPE" VARCHAR2(80 BYTE) ,
  "WATERNETWORKTYPE" VARCHAR2(80 BYTE) ,
  "MATERIAL" VARCHAR2(25 BYTE) ,
  "DIAMETER" NUMBER,
  "INTERNALDIAMETER" NUMBER,
  "MEASUREDLENGTH" NUMBER,
  "ROUGHNESSCOEFFICIENT" NUMBER,
  "QUALITYLEVEL" VARCHAR2(40 BYTE) ,
  "OPERATIONALSTATUS" VARCHAR2(17 BYTE) ,
  "INVESTIGATIONLEVEL" VARCHAR2(25 BYTE) ,
  "CONFLICTID" VARCHAR2(25 BYTE) ,
  "RESOLUTION" VARCHAR2(25 BYTE) ,
  "RESOLUTIONSTATUS" VARCHAR2(25 BYTE) ,
  "DATEINSTALLED" DATE,
  "DATECHANGED" DATE,
  "SOURCEFILE" VARCHAR2(60 BYTE) ,
  "SITEID" NUMBER,
  "OBJECTID" NUMBER,
  "SEGMENTTYPE" VARCHAR2(80 BYTE) ,
  "SEGMENTSHAPETYPE" VARCHAR2(80 BYTE) ,
  "RISE" NUMBER,
  "SPAN" NUMBER,
  "BOTTOMWIDTH" NUMBER,
  "RIGHTSIDESLOPE" NUMBER,
  "LEFTSIDESLOPE" NUMBER,
  "OFFSETEND" VARCHAR2(25 BYTE) ,
  "OFFSETSTART" VARCHAR2(25 BYTE) ,
  "STATIONEND" VARCHAR2(25 BYTE) ,
  "STATIONSTART" VARCHAR2(25 BYTE) ,
  "COMMENTS" VARCHAR2(1024 BYTE) ,
  "OGC_GEOMETRY" "MDSYS"."SDO_GEOMETRY" ,
  "XFM_ID" VARCHAR2(36 BYTE)
);

```

```
-- Domain Tables
```

```
-- Table DOMAIN_BRIDGETYPE
```

```

DROP TABLE "GIS"."DOMAIN_BRIDGETYPE" cascade constraints;
CREATE TABLE "GIS"."DOMAIN_BRIDGETYPE"

```

```
( "TYPE" VARCHAR2(64 BYTE),
"DESCRIPTION" VARCHAR2(64 BYTE)
) ;
```

```
-----
-- Table DOMAIN_COMNDETYPE
-----
```

```
DROP TABLE "GIS"."DOMAIN_COMNDETYPE" cascade constraints;
CREATE TABLE "GIS"."DOMAIN_COMNDETYPE"
( "TYPE" VARCHAR2(64 BYTE),
"DESCRIPTION" VARCHAR2(64 BYTE)
) ;
```

```
-----
-- Table DOMAIN_COMNETTYPE
-----
```

```
DROP TABLE "GIS"."DOMAIN_COMNETTYPE" cascade constraints;
CREATE TABLE "GIS"."DOMAIN_COMNETTYPE"
( "TYPE" VARCHAR2(64 BYTE),
"DESCRIPTION" VARCHAR2(64 BYTE)
) ;
```

```
-----
-- Table DOMAIN_COMSECTYPE
-----
```

```
DROP TABLE "GIS"."DOMAIN_COMSECTYPE" cascade constraints;
CREATE TABLE "GIS"."DOMAIN_COMSECTYPE"
( "TYPE" VARCHAR2(64 BYTE),
"DESCRIPTION" VARCHAR2(64 BYTE)
) ;
```

```
-----
-- Table DOMAIN_CONFLICTRESOL
-----
```

```
DROP TABLE "GIS"."DOMAIN_CONFLICTRESOL" cascade constraints;
CREATE TABLE "GIS"."DOMAIN_CONFLICTRESOL"
( "TYPE" VARCHAR2(64 BYTE),
"DESCRIPTION" VARCHAR2(64 BYTE)
) ;
```

```
-----
-- Table DOMAIN_CONFLICTTYPE
-----
```

```
DROP TABLE "GIS"."DOMAIN_CONFLICTTYPE" cascade constraints;
CREATE TABLE "GIS"."DOMAIN_CONFLICTTYPE"
( "TYPE" VARCHAR2(25 BYTE),
"DESCRIPTION" VARCHAR2(25 BYTE)
) ;
```

```
-----
-- Table DOMAIN_COORDINATESYSTEM
-----
```

```
DROP TABLE "GIS"."DOMAIN_COORDINATESYSTEM" cascade constraints;
CREATE TABLE "GIS"."DOMAIN_COORDINATESYSTEM"
( "TYPE" VARCHAR2(64 BYTE),
"DESCRIPTION" VARCHAR2(64 BYTE)
) ;
```

```
-----
-- Table DOMAIN_ELEVATIONCONTOURTYPE
-----
```

```
DROP TABLE "GIS"."DOMAIN_ELEVATIONCONTOURTYPE" cascade constraints;
CREATE TABLE "GIS"."DOMAIN_ELEVATIONCONTOURTYPE"
```

```

( "TYPE" VARCHAR2(64 BYTE),
"DESCRIPTION" VARCHAR2(64 BYTE)
) ;
-----
-- Table DOMAIN_ENDETYPE
-----
DROP TABLE "GIS"."DOMAIN_ENDETYPE" cascade constraints;
CREATE TABLE "GIS"."DOMAIN_ENDETYPE"
( "TYPE" VARCHAR2(64 BYTE),
"DESCRIPTION" VARCHAR2(64 BYTE)
) ;
-----
-- Table DOMAIN_ENETTYPE
-----
DROP TABLE "GIS"."DOMAIN_ENETTYPE" cascade constraints;
CREATE TABLE "GIS"."DOMAIN_ENETTYPE"
( "TYPE" VARCHAR2(64 BYTE),
"DESCRIPTION" VARCHAR2(64 BYTE)
) ;
-----
-- Table DOMAIN_ESEGTYPE
-----
DROP TABLE "GIS"."DOMAIN_ESEGTYPE" cascade constraints;
CREATE TABLE "GIS"."DOMAIN_ESEGTYPE"
( "TYPE" VARCHAR2(64 BYTE),
"DESCRIPTION" VARCHAR2(64 BYTE)
) ;
-----
-- Table DOMAIN_EXTERNALINTERESTTYPE
-----
DROP TABLE "GIS"."DOMAIN_EXTERNALINTERESTTYPE" cascade constraints;
CREATE TABLE "GIS"."DOMAIN_EXTERNALINTERESTTYPE"
( "TYPE" VARCHAR2(64 BYTE),
"DESCRIPTION" VARCHAR2(64 BYTE)
) ;
-----
-- Table DOMAIN_FENCEUSETYPE
-----
DROP TABLE "GIS"."DOMAIN_FENCEUSETYPE" cascade constraints;
CREATE TABLE "GIS"."DOMAIN_FENCEUSETYPE"
( "TYPE" VARCHAR2(64 BYTE),
"DESCRIPTION" VARCHAR2(64 BYTE)
) ;
-----
-- Table DOMAIN_FITTYPE
-----
DROP TABLE "GIS"."DOMAIN_FITTYPE" cascade constraints;
CREATE TABLE "GIS"."DOMAIN_FITTYPE"
( "TYPE" VARCHAR2(64 BYTE),
"DESCRIPTION" VARCHAR2(64 BYTE)
) ;
-----
-- Table DOMAIN_GASNDETYPE
-----
DROP TABLE "GIS"."DOMAIN_GASNDETYPE" cascade constraints;
CREATE TABLE "GIS"."DOMAIN_GASNDETYPE"

```

```

( "TYPE" VARCHAR2(64 BYTE),
"DESCRIPTION" VARCHAR2(64 BYTE)
) ;
-----
-- Table DOMAIN_GASNETTYPE
-----
DROP TABLE "GIS"."DOMAIN_GASNETTYPE" cascade constraints;
CREATE TABLE "GIS"."DOMAIN_GASNETTYPE"
( "TYPE" VARCHAR2(64 BYTE),
"DESCRIPTION" VARCHAR2(64 BYTE)
) ;
-----
-- Table DOMAIN_GASSEGTYPE
-----
DROP TABLE "GIS"."DOMAIN_GASSEGTYPE" cascade constraints;
CREATE TABLE "GIS"."DOMAIN_GASSEGTYPE"
( "TYPE" VARCHAR2(64 BYTE),
"DESCRIPTION" VARCHAR2(64 BYTE)
) ;
-----
-- Table DOMAIN_GSIP_LENGTHUOM
-----
DROP TABLE "GIS"."DOMAIN_GSIP_LENGTHUOM" cascade constraints;
CREATE TABLE "GIS"."DOMAIN_GSIP_LENGTHUOM"
( "TYPE" VARCHAR2(64 BYTE),
"DESCRIPTION" VARCHAR2(64 BYTE)
) ;
-----
-- Table DOMAIN_HORIZONTALDATUMTYPE
-----
DROP TABLE "GIS"."DOMAIN_HORIZONTALDATUMTYPE" cascade constraints;
CREATE TABLE "GIS"."DOMAIN_HORIZONTALDATUMTYPE"
( "TYPE" VARCHAR2(64 BYTE),
"DESCRIPTION" VARCHAR2(64 BYTE)
) ;
-----
-- Table DOMAIN_MONUMENTPOINTTYPE
-----
DROP TABLE "GIS"."DOMAIN_MONUMENTPOINTTYPE" cascade constraints;
CREATE TABLE "GIS"."DOMAIN_MONUMENTPOINTTYPE"
( "TYPE" VARCHAR2(64 BYTE),
"DESCRIPTION" VARCHAR2(64 BYTE)
) ;
-----
-- Table DOMAIN_NDESHPTYPE
-----
DROP TABLE "GIS"."DOMAIN_NDESHPTYPE" cascade constraints;
CREATE TABLE "GIS"."DOMAIN_NDESHPTYPE"
( "TYPE" VARCHAR2(64 BYTE),
"DESCRIPTION" VARCHAR2(64 BYTE)
) ;
-----
-- Table DOMAIN_NETWORKSUBTYPE
-----
DROP TABLE "GIS"."DOMAIN_NETWORKSUBTYPE" cascade constraints;
CREATE TABLE "GIS"."DOMAIN_NETWORKSUBTYPE"

```



```

( "TYPE" VARCHAR2(64 BYTE),
"DESCRIPTION" VARCHAR2(64 BYTE)
) ;
-----
-- Table DOMAIN_NETWORKTYPE
-----
CREATE TABLE "GIS"."DOMAIN_NETWORKTYPE"
( "TYPE" VARCHAR2(64 BYTE),
"DESCRIPTION" VARCHAR2(64 BYTE)
) ;
-----
-- Table DOMAIN_PAVEMENTSECTIONT
-----
DROP TABLE "GIS"."DOMAIN_PAVEMENTSECTIONT" cascade constraints;
DROP TABLE "GIS"."DOMAIN_NETWORKTYPE" cascade constraints;
CREATE TABLE "GIS"."DOMAIN_PAVEMENTSECTIONT"
( "TYPE" VARCHAR2(64 BYTE),
"DESCRIPTION" VARCHAR2(64 BYTE)
) ;
-----
-- Table DOMAIN_PIPEMATERIAL
-----
DROP TABLE "GIS"."DOMAIN_PIPEMATERIAL" cascade constraints;
CREATE TABLE "GIS"."DOMAIN_PIPEMATERIAL"
( "TYPE" VARCHAR2(64 BYTE),
"DESCRIPTION" VARCHAR2(64 BYTE)
) ;
-----
-- Table DOMAIN_POLNDETYPE
-----
DROP TABLE "GIS"."DOMAIN_POLNDETYPE" cascade constraints;
CREATE TABLE "GIS"."DOMAIN_POLNDETYPE"
( "TYPE" VARCHAR2(64 BYTE),
"DESCRIPTION" VARCHAR2(64 BYTE)
) ;
-----
-- Table DOMAIN_POLNETTYPE
-----
DROP TABLE "GIS"."DOMAIN_POLNETTYPE" cascade constraints;
CREATE TABLE "GIS"."DOMAIN_POLNETTYPE"
( "TYPE" VARCHAR2(64 BYTE),
"DESCRIPTION" VARCHAR2(64 BYTE)
) ;
-----
-- Table DOMAIN_POLSEGTYPE
-----
DROP TABLE "GIS"."DOMAIN_POLSEGTYPE" cascade constraints;
CREATE TABLE "GIS"."DOMAIN_POLSEGTYPE"
( "TYPE" VARCHAR2(64 BYTE),
"DESCRIPTION" VARCHAR2(64 BYTE)
) ;
-----
-- Table DOMAIN_RAILCONSTRUCTIONTYPE
-----
DROP TABLE "GIS"."DOMAIN_RAILCONSTRUCTIONTYPE" cascade constraints;
CREATE TABLE "GIS"."DOMAIN_RAILCONSTRUCTIONTYPE"

```

```
( "TYPE" VARCHAR2(64 BYTE),
"DESCRIPTION" VARCHAR2(64 BYTE)
) ;
```

```
-----
-- Table DOMAIN_RECREATIONAREATYPE
-----
```

```
DROP TABLE "GIS"."DOMAIN_RECREATIONAREATYPE" cascade constraints;
CREATE TABLE "GIS"."DOMAIN_RECREATIONAREATYPE"
( "TYPE" VARCHAR2(64 BYTE),
"DESCRIPTION" VARCHAR2(64 BYTE)
) ;
```

```
-----
-- Table DOMAIN_SEGSHPTYPE
-----
```

```
DROP TABLE "GIS"."DOMAIN_SEGSHPTYPE" cascade constraints;
CREATE TABLE "GIS"."DOMAIN_SEGSHPTYPE"
( "TYPE" VARCHAR2(64 BYTE),
"DESCRIPTION" VARCHAR2(64 BYTE)
) ;
```

```
-----
-- Table DOMAIN_SEGTYPE
-----
```

```
DROP TABLE "GIS"."DOMAIN_SEGTYPE" cascade constraints;
CREATE TABLE "GIS"."DOMAIN_SEGTYPE"
( "TYPE" VARCHAR2(64 BYTE),
"DESCRIPTION" VARCHAR2(64 BYTE)
) ;
```

```
-----
-- Table DOMAIN_SIGNTYPE
-----
```

```
DROP TABLE "GIS"."DOMAIN_SIGNTYPE" cascade constraints;
CREATE TABLE "GIS"."DOMAIN_SIGNTYPE"
( "TYPE" VARCHAR2(64 BYTE),
"DESCRIPTION" VARCHAR2(64 BYTE)
) ;
```

```
-----
-- Table DOMAIN_STRUCTURALCONDITION
-----
```

```
DROP TABLE "GIS"."DOMAIN_STRUCTURALCONDITION" cascade constraints;
CREATE TABLE "GIS"."DOMAIN_STRUCTURALCONDITION"
( "TYPE" VARCHAR2(64 BYTE),
"DESCRIPTION" VARCHAR2(64 BYTE)
) ;
```

```
-----
-- Table DOMAIN_STRUCTUREMATERIAL
-----
```

```
DROP TABLE "GIS"."DOMAIN_STRUCTUREMATERIAL" cascade constraints;
CREATE TABLE "GIS"."DOMAIN_STRUCTUREMATERIAL"
( "TYPE" VARCHAR2(64 BYTE),
"DESCRIPTION" VARCHAR2(64 BYTE)
) ;
```

```
-----
-- Table DOMAIN_SURVEYMETHOD
-----
```

```
DROP TABLE "GIS"."DOMAIN_SURVEYMETHOD" cascade constraints;
CREATE TABLE "GIS"."DOMAIN_SURVEYMETHOD"
```

```

( "TYPE" VARCHAR2(64 BYTE),
"DESCRIPTION" VARCHAR2(64 BYTE)
) ;
-----
-- Table DOMAIN_SURVEYSOURCETYPE
-----
DROP TABLE "GIS"."DOMAIN_SURVEYSOURCETYPE" cascade constraints;
CREATE TABLE "GIS"."DOMAIN_SURVEYSOURCETYPE"
( "TYPE" VARCHAR2(64 BYTE),
"DESCRIPTION" VARCHAR2(64 BYTE)
) ;
-----
-- Table DOMAIN_SURVEYTYPE
-----
DROP TABLE "GIS"."DOMAIN_SURVEYTYPE" cascade constraints;
CREATE TABLE "GIS"."DOMAIN_SURVEYTYPE"
( "TYPE" VARCHAR2(64 BYTE),
"DESCRIPTION" VARCHAR2(64 BYTE)
) ;
-----
-- Table DOMAIN_THMNETTYPE
-----
DROP TABLE "GIS"."DOMAIN_THMNETTYPE" cascade constraints;
CREATE TABLE "GIS"."DOMAIN_THMNETTYPE"
( "TYPE" VARCHAR2(64 BYTE),
"DESCRIPTION" VARCHAR2(64 BYTE)
) ;
-----
-- Table DOMAIN_THMNODTYPE
-----
DROP TABLE "GIS"."DOMAIN_THMNODTYPE" cascade constraints;
CREATE TABLE "GIS"."DOMAIN_THMNODTYPE"
( "TYPE" VARCHAR2(64 BYTE),
"DESCRIPTION" VARCHAR2(64 BYTE)
) ;
-----
-- Table DOMAIN_THMSEGTYPE
-----
DROP TABLE "GIS"."DOMAIN_THMSEGTYPE" cascade constraints;
CREATE TABLE "GIS"."DOMAIN_THMSEGTYPE"
( "TYPE" VARCHAR2(64 BYTE),
"DESCRIPTION" VARCHAR2(64 BYTE)
) ;
-----
-- Table DOMAIN_TOWERUSETYPE
-----
DROP TABLE "GIS"."DOMAIN_TOWERUSETYPE" cascade constraints;
CREATE TABLE "GIS"."DOMAIN_TOWERUSETYPE"
( "TYPE" VARCHAR2(64 BYTE),
"DESCRIPTION" VARCHAR2(64 BYTE)
) ;
-----
-- Table DOMAIN_TRANSTUNNELTYPE
-----
DROP TABLE "GIS"."DOMAIN_TRANSTUNNELTYPE" cascade constraints;
CREATE TABLE "GIS"."DOMAIN_TRANSTUNNELTYPE"

```

```

( "TYPE" VARCHAR2(64 BYTE),
"DESCRIPTION" VARCHAR2(64 BYTE)
) ;
-----
-- Table DOMAIN_UTILITYDATAQUALITY
-----
DROP TABLE "GIS"."DOMAIN_UTILITYDATAQUALITY" cascade constraints;
CREATE TABLE "GIS"."DOMAIN_UTILITYDATAQUALITY"
( "TYPE" VARCHAR2(64 BYTE),
"DESCRIPTION" VARCHAR2(64 BYTE)
) ;
-----
-- Table DOMAIN_UTILITYFEATURET
-----
DROP TABLE "GIS"."DOMAIN_UTILITYFEATURET" cascade constraints;
CREATE TABLE "GIS"."DOMAIN_UTILITYFEATURET"
( "TYPE" VARCHAR2(64 BYTE),
"DESCRIPTION" VARCHAR2(64 BYTE)
) ;
-----
-- Table DOMAIN_UTILITYINVESTATIONLEVEL
-----
DROP TABLE "GIS"."DOMAIN_UTILITYINVESTATIONLEVEL" cascade constraints;
CREATE TABLE "GIS"."DOMAIN_UTILITYINVESTATIONLEVEL"
( "TYPE" VARCHAR2(64 BYTE),
"DESCRIPTION" VARCHAR2(64 BYTE)
) ;
-----
-- Table DOMAIN_UTILITYRESOLUTIONS
-----
DROP TABLE "GIS"."DOMAIN_UTILITYRESOLUTIONS" cascade constraints;
CREATE TABLE "GIS"."DOMAIN_UTILITYRESOLUTIONS"
( "TYPE" VARCHAR2(64 BYTE),
"DESCRIPTION" VARCHAR2(64 BYTE)
) ;
-----
-- Table DOMAIN_UTILITYRESOLUTIONSTATUS
-----
DROP TABLE "GIS"."DOMAIN_UTILITYRESOLUTIONSTATUS" cascade constraints;
CREATE TABLE "GIS"."DOMAIN_UTILITYRESOLUTIONSTATUS"
( "TYPE" VARCHAR2(64 BYTE),
"DESCRIPTION" VARCHAR2(64 BYTE)
) ;
-----
-- Table DOMAIN_UTILOPSTAT
-----
DROP TABLE "GIS"."DOMAIN_UTILOPSTAT" cascade constraints;
CREATE TABLE "GIS"."DOMAIN_UTILOPSTAT"
( "TYPE" VARCHAR2(64 BYTE),
"DESCRIPTION" VARCHAR2(64 BYTE)
) ;
-----
-- Table DOMAIN_UTLNDETYPE
-----
DROP TABLE "GIS"."DOMAIN_UTLNDETYPE" cascade constraints;
CREATE TABLE "GIS"."DOMAIN_UTLNDETYPE"

```

```

( "TYPE" VARCHAR2(64 BYTE),
"DESCRIPTION" VARCHAR2(64 BYTE)
) ;
-----
-- Table DOMAIN_VERTICALDATUMTYPE
-----
DROP TABLE "GIS"."DOMAIN_VERTICALDATUMTYPE" cascade constraints;
CREATE TABLE "GIS"."DOMAIN_VERTICALDATUMTYPE"
( "TYPE" VARCHAR2(64 BYTE),
"DESCRIPTION" VARCHAR2(64 BYTE)
) ;
-----
-- Table DOMAIN_VOLTTYPE
-----
DROP TABLE "GIS"."DOMAIN_VOLTTYPE" cascade constraints;
CREATE TABLE "GIS"."DOMAIN_VOLTTYPE"
( "TYPE" VARCHAR2(64 BYTE),
"DESCRIPTION" VARCHAR2(64 BYTE)
) ;
-----
-- Table DOMAIN_WALLTYPE
-----
DROP TABLE "GIS"."DOMAIN_WALLTYPE" cascade constraints;
CREATE TABLE "GIS"."DOMAIN_WALLTYPE"
( "TYPE" VARCHAR2(64 BYTE),
"DESCRIPTION" VARCHAR2(64 BYTE)
) ;
-----
-- Table DOMAIN_WATERCOURSEELEMENTTYPE
-----
DROP TABLE "GIS"."DOMAIN_WATERCOURSEELEMENTTYPE" cascade constraints;
CREATE TABLE "GIS"."DOMAIN_WATERCOURSEELEMENTTYPE"
( "TYPE" VARCHAR2(64 BYTE),
"DESCRIPTION" VARCHAR2(64 BYTE)
) ;
-----
-- Table DOMAIN_WTRNDETYPE
-----
DROP TABLE "GIS"."DOMAIN_WTRNDETYPE" cascade constraints;
CREATE TABLE "GIS"."DOMAIN_WTRNDETYPE"
( "TYPE" VARCHAR2(64 BYTE),
"DESCRIPTION" VARCHAR2(64 BYTE)
) ;
-----
-- Table DOMAIN_WTRNETTYPE
-----
DROP TABLE "GIS"."DOMAIN_WTRNETTYPE" cascade constraints;
CREATE TABLE "GIS"."DOMAIN_WTRNETTYPE"
( "TYPE" VARCHAR2(64 BYTE),
"DESCRIPTION" VARCHAR2(64 BYTE)
) ;
-----
-- Table DOMAIN_WTRSEGTYPE
-----
DROP TABLE "GIS"."DOMAIN_WTRSEGTYPE" cascade constraints;
CREATE TABLE "GIS"."DOMAIN_WTRSEGTYPE"

```

```

( "TYPE" VARCHAR2(64 BYTE),
"DESCRIPTION" VARCHAR2(64 BYTE)
) ;
-----
-- Table DOMAIN_WWNDETYPE
-----
DROP TABLE "GIS"."DOMAIN_WWNDETYPE" cascade constraints;
CREATE TABLE "GIS"."DOMAIN_WWNDETYPE"
( "TYPE" VARCHAR2(64 BYTE),
"DESCRIPTION" VARCHAR2(64 BYTE)
) ;
-----
-- Table DOMAIN_WWNETTYPE
-----
DROP TABLE "GIS"."DOMAIN_WWNETTYPE" cascade constraints;
CREATE TABLE "GIS"."DOMAIN_WWNETTYPE"
( "TYPE" VARCHAR2(64 BYTE),
"DESCRIPTION" VARCHAR2(64 BYTE)
) ;
-----
-- Table DOMAIN_WWSEGTYPE
-----
DROP TABLE "GIS"."DOMAIN_WWSEGTYPE" cascade constraints;
CREATE TABLE "GIS"."DOMAIN_WWSEGTYPE"
( "TYPE" VARCHAR2(64 BYTE),
"DESCRIPTION" VARCHAR2(64 BYTE)
) ;
-----
-- Table Indexes
-----
-----
-- Index BRIDGE_SIDX
-----
CREATE INDEX "GIS"."BRIDGE_SIDX" ON "GIS"."BRIDGE" ("OGC_GEOMETRY")
INDEXTYPE IS "MDSYS"."SPATIAL_INDEX" PARAMETERS ('layer_gtype=polygon');
-----
-- Index PK_BRIDGE
-----
CREATE UNIQUE INDEX "GIS"."PK_BRIDGE" ON "GIS"."BRIDGE" ("XFM_ID") ;
-----
-- Index BUILDING_SIDX
-----
CREATE INDEX "GIS"."BUILDING_SIDX" ON "GIS"."BUILDING" ("OGC_GEOMETRY")
INDEXTYPE IS "MDSYS"."SPATIAL_INDEX" PARAMETERS ('layer_gtype=multipolygon');
-----
-- Index PK_BUILDING
-----
CREATE UNIQUE INDEX "GIS"."PK_BUILDING" ON "GIS"."BUILDING" ("XFM_ID") ;
-----
-- Index COMMUNICATIONNODE_SIDX
-----
CREATE INDEX "GIS"."COMMUNICATIONNODE_SIDX" ON "GIS"."COMMUNICATIONNODE"
("OGC_GEOMETRY")
INDEXTYPE IS "MDSYS"."SPATIAL_INDEX" PARAMETERS ('layer_gtype=point');
-----

```

```

-- Index PK_COMMUNICATIONNODE
-----
CREATE UNIQUE INDEX "GIS"."PK_COMMUNICATIONNODE" ON "GIS"."COMMUNICATIONNODE"
("XFM_ID") ;
-----
-- Index COMMUNICATIONSEGMENT_SIDX
-----
CREATE INDEX "GIS"."COMMUNICATIONSEGMENT_SIDX" ON "GIS"."COMMUNICATIONSEGMENT"
("OGC_GEOMETRY")
INDEXTYPE IS "MDSYS"."SPATIAL_INDEX" PARAMETERS ('layer_gtype=curve');
-----
-- Index PK_COMMUNICATIONSEGMENT
-----
CREATE UNIQUE INDEX "GIS"."PK_COMMUNICATIONSEGMENT" ON "GIS"."COMMUNICATIONSEGMENT"
("XFM_ID") ;
-----
-- Index PK_CONFLICTNODE
-----
CREATE UNIQUE INDEX "GIS"."PK_CONFLICTNODE" ON "GIS"."CONFLICTNODE" ("XFM_ID") ;
-----
-- Index CONTROLMONUMENTPOINT_SIDX
-----
CREATE INDEX "GIS"."CONTROLMONUMENTPOINT_SIDX" ON "GIS"."CONTROLMONUMENTPOINT"
("OGC_GEOMETRY")
INDEXTYPE IS "MDSYS"."SPATIAL_INDEX" PARAMETERS ('layer_gtype=point');
-----
-- Index PK_CONTROLMONUMENTPOINT
-----
CREATE UNIQUE INDEX "GIS"."PK_CONTROLMONUMENTPOINT" ON "GIS"."CONTROLMONUMENTPOINT"
("XFM_ID") ;
-----
-- Index CONSTRUCTIONLINE_SIDX
-----
CREATE INDEX "GIS"."CONSTRUCTIONLINE_SIDX" ON "GIS"."CONSTRUCTIONLINE"
("OGC_GEOMETRY")
INDEXTYPE IS "MDSYS"."SPATIAL_INDEX" PARAMETERS ('layer_gtype=curve');
-----
-- Index PK_CONSTRUCTIONLINE
-----
CREATE UNIQUE INDEX "GIS"."PK_CONSTRUCTIONLINE" ON "GIS"."CONSTRUCTIONLINE"
("XFM_ID") ;
-----
-- Index DOTPERMIT_SIDX
-----
CREATE INDEX "GIS"."DOTPERMIT_SIDX" ON "GIS"."DOTPERMIT" ("OGC_GEOMETRY")
INDEXTYPE IS "MDSYS"."SPATIAL_INDEX" PARAMETERS ('layer_gtype=polygon');
-----
-- Index PK_DOTPERMIT
-----
CREATE UNIQUE INDEX "GIS"."PK_DOTPERMIT" ON "GIS"."DOTPERMIT" ("XFM_ID") ;
-----
-- Index ELECCONDUITBANKSEGMENT_SIDX
-----
CREATE INDEX "GIS"."ELECCONDUITBANKSEGMENT_SIDX" ON "GIS"."ELECCONDUITBANKSEGMENT"
("OGC_GEOMETRY")
INDEXTYPE IS "MDSYS"."SPATIAL_INDEX" PARAMETERS ('layer_gtype=curve');

```

```

-----
-- Index PK_ELECCONDUITBANKSEGMENT
-----
CREATE UNIQUE INDEX "GIS"."PK_ELECCONDUITBANKSEGMENT" ON
"GIS"."ELECCONDUITBANKSEGMENT" ("XFM_ID") ;
-----
-- Index ELECTRICALNODE_SIDX
-----
CREATE INDEX "GIS"."ELECTRICALNODE_SIDX" ON "GIS"."ELECTRICALNODE" ("OGC_GEOMETRY")
INDEXTYPE IS "MDSYS"."SPATIAL_INDEX" PARAMETERS ('layer_gtype=point');
-----
-- Index PK_ELECTRICALNODE
-----
CREATE UNIQUE INDEX "GIS"."PK_ELECTRICALNODE" ON "GIS"."ELECTRICALNODE" ("XFM_ID")
;
-----
-- Index ELECTRICALSEGMENT_SIDX
-----
CREATE INDEX "GIS"."ELECTRICALSEGMENT_SIDX" ON "GIS"."ELECTRICALSEGMENT"
("OGC_GEOMETRY")
INDEXTYPE IS "MDSYS"."SPATIAL_INDEX" PARAMETERS ('layer_gtype=curve');
-----
-- Index PK_ELECTRICALSEGMENT
-----
CREATE UNIQUE INDEX "GIS"."PK_ELECTRICALSEGMENT" ON "GIS"."ELECTRICALSEGMENT"
("XFM_ID") ;
-----
-- Index ELEVATIONCONTOUR_SIDX
-----
CREATE INDEX "GIS"."ELEVATIONCONTOUR_SIDX" ON "GIS"."ELEVATIONCONTOUR"
("OGC_GEOMETRY")
INDEXTYPE IS "MDSYS"."SPATIAL_INDEX" PARAMETERS ('layer_gtype=curve');
-----
-- Index PK_ELEVATIONCONTOUR
-----
CREATE UNIQUE INDEX "GIS"."PK_ELEVATIONCONTOUR" ON "GIS"."ELEVATIONCONTOUR"
("XFM_ID") ;
-----
-- Index EXTERNALPROPERTYINTEREST_SIDX
-----
CREATE INDEX "GIS"."EXTERNALPROPERTYINTEREST_SIDX" ON
"GIS"."EXTERNALPROPERTYINTEREST" ("OGC_GEOMETRY")
INDEXTYPE IS "MDSYS"."SPATIAL_INDEX" PARAMETERS ('layer_gtype=polygon');
-----
-- Index PK_EXTERNALPROPERTYINTEREST
-----
CREATE UNIQUE INDEX "GIS"."PK_EXTERNALPROPERTYINTEREST" ON
"GIS"."EXTERNALPROPERTYINTEREST" ("XFM_ID") ;
-----
-- Index FENCE_SIDX
-----
CREATE INDEX "GIS"."FENCE_SIDX" ON "GIS"."FENCE" ("OGC_GEOMETRY")
INDEXTYPE IS "MDSYS"."SPATIAL_INDEX" PARAMETERS ('layer_gtype=curve');
-----
-- Index PK_FENCE
-----

```



```

CREATE UNIQUE INDEX "GIS"."PK_FENCE" ON "GIS"."FENCE" ("XFM_ID") ;
-----
-- Index GASNODE_SIDX
-----
CREATE INDEX "GIS"."GASNODE_SIDX" ON "GIS"."GASNODE" ("OGC_GEOMETRY")
  INDEXTYPE IS "MDSYS"."SPATIAL_INDEX"  PARAMETERS ('layer_gtype=point');
-----
-- Index PK_GASNODE
-----
CREATE UNIQUE INDEX "GIS"."PK_GASNODE" ON "GIS"."GASNODE" ("XFM_ID") ;
-----
-- Index GASSEGMENT_SIDX
-----
CREATE INDEX "GIS"."GASSEGMENT_SIDX" ON "GIS"."GASSEGMENT" ("OGC_GEOMETRY")
  INDEXTYPE IS "MDSYS"."SPATIAL_INDEX"  PARAMETERS ('layer_gtype=curve');
-----
-- Index PK_GASSEGMENT
-----
CREATE UNIQUE INDEX "GIS"."PK_GASSEGMENT" ON "GIS"."GASSEGMENT" ("XFM_ID") ;
-----
-- Index GRID_SIDX
-----
CREATE INDEX "GIS"."GRID_SIDX" ON "GIS"."GRID" ("OGC_GEOMETRY")
  INDEXTYPE IS "MDSYS"."SPATIAL_INDEX"  PARAMETERS ('layer_gtype=polygon');
-----
-- Index PK_GRID
-----
CREATE UNIQUE INDEX "GIS"."PK_GRID" ON "GIS"."GRID" ("XFM_ID") ;
-----
-- Index GUARDRAIL_SIDX
-----
CREATE INDEX "GIS"."GUARDRAIL_SIDX" ON "GIS"."GUARDRAIL" ("OGC_GEOMETRY")
  INDEXTYPE IS "MDSYS"."SPATIAL_INDEX"  PARAMETERS ('layer_gtype=curve');
-----
-- Index PK_GUARDRAIL
-----
CREATE UNIQUE INDEX "GIS"."PK_GUARDRAIL" ON "GIS"."GUARDRAIL" ("XFM_ID") ;
-----
-- Index INSTALLATION_SIDX
-----
CREATE INDEX "GIS"."INSTALLATION_SIDX" ON "GIS"."INSTALLATION" ("OGC_GEOMETRY")
  INDEXTYPE IS "MDSYS"."SPATIAL_INDEX"  PARAMETERS ('layer_gtype=polygon');
-----
-- Index PK_INSTALLATION
-----
CREATE UNIQUE INDEX "GIS"."PK_INSTALLATION" ON "GIS"."INSTALLATION" ("XFM_ID") ;
-----
-- Index LANDPARCEL_SIDX
-----
CREATE INDEX "GIS"."LANDPARCEL_SIDX" ON "GIS"."LANDPARCEL" ("OGC_GEOMETRY")
  INDEXTYPE IS "MDSYS"."SPATIAL_INDEX"  PARAMETERS ('layer_gtype=polygon');
-----
-- Index PK_LANDPARCEL
-----
CREATE UNIQUE INDEX "GIS"."PK_LANDPARCEL" ON "GIS"."LANDPARCEL" ("XFM_ID") ;
-----

```

```

-- Index PAVEMENTSECTION_SIDX
-----
CREATE INDEX "GIS"."PAVEMENTSECTION_SIDX" ON "GIS"."PAVEMENTSECTION"
("OGC_GEOMETRY")
  INDEXTYPE IS "MDSYS"."SPATIAL_INDEX"  PARAMETERS ('layer_gtype=multipolygon');
-----
-- Index PK_PAVEMENTSECTION
-----
CREATE UNIQUE INDEX "GIS"."PK_PAVEMENTSECTION" ON "GIS"."PAVEMENTSECTION" ("XFM_ID")
;
-----
-- Index POLNODE_SIDX
-----
CREATE INDEX "GIS"."POLNODE_SIDX" ON "GIS"."POLNODE" ("OGC_GEOMETRY")
  INDEXTYPE IS "MDSYS"."SPATIAL_INDEX"  PARAMETERS ('layer_gtype=point');
-----
-- Index PK_POLNODE
-----
CREATE UNIQUE INDEX "GIS"."PK_POLNODE" ON "GIS"."POLNODE" ("XFM_ID") ;
-----
-- Index POLSEGMENT_SIDX
-----
CREATE INDEX "GIS"."POLSEGMENT_SIDX" ON "GIS"."POLSEGMENT" ("OGC_GEOMETRY")
  INDEXTYPE IS "MDSYS"."SPATIAL_INDEX"  PARAMETERS ('layer_gtype=curve');
-----
-- Index PK_POLSEGMENT
-----
CREATE UNIQUE INDEX "GIS"."PK_POLSEGMENT" ON "GIS"."POLSEGMENT" ("XFM_ID") ;
-----
-- Index PROJECTREFERENCE_SIDX
-----
CREATE INDEX "GIS"."PROJECTREFERENCE_SIDX" ON "GIS"."PROJECTREFERENCE"
("OGC_GEOMETRY")
  INDEXTYPE IS "MDSYS"."SPATIAL_INDEX"  PARAMETERS ('layer_gtype=polygon');
-----
-- Index PK_PROJECTREFERENCE
-----
CREATE UNIQUE INDEX "GIS"."PK_PROJECTREFERENCE" ON "GIS"."PROJECTREFERENCE"
("XFM_ID") ;
-----
-- Index RAILTRACK_SIDX
-----
CREATE INDEX "GIS"."RAILTRACK_SIDX" ON "GIS"."RAILTRACK" ("OGC_GEOMETRY")
  INDEXTYPE IS "MDSYS"."SPATIAL_INDEX"  PARAMETERS ('layer_gtype=curve');
-----
-- Index PK_RAILTRACK
-----
CREATE UNIQUE INDEX "GIS"."PK_RAILTRACK" ON "GIS"."RAILTRACK" ("XFM_ID") ;
-----
-- Index RECREATIONAREA_SIDX
-----
CREATE INDEX "GIS"."RECREATIONAREA_SIDX" ON "GIS"."RECREATIONAREA" ("OGC_GEOMETRY")
  INDEXTYPE IS "MDSYS"."SPATIAL_INDEX"  PARAMETERS ('layer_gtype=polygon');
-----
-- Index PK_RECREATIONAREA
-----

```

```

CREATE UNIQUE INDEX "GIS"."PK_RECREATIONAREA" ON "GIS"."RECREATIONAREA" ("XFM_ID")
;
-----
-- Index RECREATIONFEATURE_SIDX
-----
CREATE INDEX "GIS"."RECREATIONFEATURE_SIDX" ON "GIS"."RECREATIONFEATURE"
("OGC_GEOMETRY")
INDEXTYPE IS "MDSYS"."SPATIAL_INDEX" PARAMETERS ('layer_gtype=point');
-----
-- Index PK_RECREATIONFEATURE
-----
CREATE UNIQUE INDEX "GIS"."PK_RECREATIONFEATURE" ON "GIS"."RECREATIONFEATURE"
("XFM_ID") ;
-----
-- Index RESTRICTEDAREA_SIDX
-----
CREATE INDEX "GIS"."RESTRICTEDAREA_SIDX" ON "GIS"."RESTRICTEDAREA" ("OGC_GEOMETRY")
INDEXTYPE IS "MDSYS"."SPATIAL_INDEX" PARAMETERS ('layer_gtype=polygon');
-----
-- Index PK_RESTRICTEDAREA
-----
CREATE UNIQUE INDEX "GIS"."PK_RESTRICTEDAREA" ON "GIS"."RESTRICTEDAREA" ("XFM_ID")
;
-----
-- Index ROADPATH_SIDX
-----
CREATE INDEX "GIS"."ROADPATH_SIDX" ON "GIS"."ROADPATH" ("OGC_GEOMETRY")
INDEXTYPE IS "MDSYS"."SPATIAL_INDEX" PARAMETERS ('layer_gtype=curve');
-----
-- Index PK_ROADPATH
-----
CREATE UNIQUE INDEX "GIS"."PK_ROADPATH" ON "GIS"."ROADPATH" ("XFM_ID") ;
-----
-- Index SIGN_SIDX
-----
CREATE INDEX "GIS"."SIGN_SIDX" ON "GIS"."SIGN" ("OGC_GEOMETRY")
INDEXTYPE IS "MDSYS"."SPATIAL_INDEX" PARAMETERS ('layer_gtype=point');
-----
-- Index PK_SIGN
-----
CREATE UNIQUE INDEX "GIS"."PK_SIGN" ON "GIS"."SIGN" ("XFM_ID") ;
-----
-- Index SITE SIDX
-----
CREATE INDEX "GIS"."SITE_SIDX" ON "GIS"."SITE" ("OGC_GEOMETRY")
INDEXTYPE IS "MDSYS"."SPATIAL_INDEX" PARAMETERS ('layer_gtype=polygon');
-----
-- Index PK_SITE
-----
CREATE UNIQUE INDEX "GIS"."PK_SITE" ON "GIS"."SITE" ("XFM_ID") ;
-----
-- Index STRUCTURE_SIDX
-----
CREATE INDEX "GIS"."STRUCTURE_SIDX" ON "GIS"."STRUCTURE" ("OGC_GEOMETRY")
INDEXTYPE IS "MDSYS"."SPATIAL_INDEX" PARAMETERS ('layer_gtype=multipolygon');
-----

```

```

-- Index PK_STRUCTURE
-----
CREATE UNIQUE INDEX "GIS"."PK_STRUCTURE" ON "GIS"."STRUCTURE" ("XFM_ID") ;
-----
-- Index SURVEYJOB_SIDX
-----
CREATE INDEX "GIS"."SURVEYJOB_SIDX" ON "GIS"."SURVEYJOB" ("OGC_GEOMETRY")
INDEXTYPE IS "MDSYS"."SPATIAL_INDEX" PARAMETERS ('layer_gtype=multipolygon');
-----
-- Index PK_SURVEYJOB
-----
CREATE UNIQUE INDEX "GIS"."PK_SURVEYJOB" ON "GIS"."SURVEYJOB" ("XFM_ID") ;
-----
-- Index SURVEYPOINT_SIDX
-----
CREATE INDEX "GIS"."SURVEYPOINT_SIDX" ON "GIS"."SURVEYPOINT" ("OGC_GEOMETRY")
INDEXTYPE IS "MDSYS"."SPATIAL_INDEX" PARAMETERS ('layer_gtype=point');
-----
-- Index PK_SURVEYPOINT
-----
CREATE UNIQUE INDEX "GIS"."PK_SURVEYPOINT" ON "GIS"."SURVEYPOINT" ("XFM_ID") ;
-----
-- Index THERMALNODE_SIDX
-----
CREATE INDEX "GIS"."THERMALNODE_SIDX" ON "GIS"."THERMALNODE" ("OGC_GEOMETRY")
INDEXTYPE IS "MDSYS"."SPATIAL_INDEX" PARAMETERS ('layer_gtype=point');
-----
-- Index PK_THERMALNODE
-----
CREATE UNIQUE INDEX "GIS"."PK_THERMALNODE" ON "GIS"."THERMALNODE" ("XFM_ID") ;
-----
-- Index THERMALSEGMENT_SIDX
-----
CREATE INDEX "GIS"."THERMALSEGMENT_SIDX" ON "GIS"."THERMALSEGMENT" ("OGC_GEOMETRY")
INDEXTYPE IS "MDSYS"."SPATIAL_INDEX" PARAMETERS ('layer_gtype=curve');
-----
-- Index PK_THERMALSEGMENT
-----
CREATE UNIQUE INDEX "GIS"."PK_THERMALSEGMENT" ON "GIS"."THERMALSEGMENT" ("XFM_ID")
;
-----
-- Index TOWER_SIDX
-----
CREATE INDEX "GIS"."TOWER_SIDX" ON "GIS"."TOWER" ("OGC_GEOMETRY")
INDEXTYPE IS "MDSYS"."SPATIAL_INDEX" PARAMETERS ('layer_gtype=point');
-----
-- Index PK_TOWER
-----
CREATE UNIQUE INDEX "GIS"."PK_TOWER" ON "GIS"."TOWER" ("XFM_ID") ;
-----
-- Index TRANSPORTATIONTUNNEL_SIDX
-----
CREATE INDEX "GIS"."TRANSPORTATIONTUNNEL_SIDX" ON "GIS"."TRANSPORTATIONTUNNEL"
("OGC_GEOMETRY")
INDEXTYPE IS "MDSYS"."SPATIAL_INDEX" PARAMETERS ('layer_gtype=polygon');
-----

```

```

-- Index PK_TRANSPORTATIONTUNNEL
-----
CREATE UNIQUE INDEX "GIS"."PK_TRANSPORTATIONTUNNEL" ON "GIS"."TRANSPORTATIONTUNNEL"
("XFM_ID") ;
-----
-- Index UTILITYFEATURE_SIDX
-----
CREATE INDEX "GIS"."UTILITYFEATURE_SIDX" ON "GIS"."UTILITYFEATURE" ("OGC_GEOMETRY")
INDEXTYPE IS "MDSYS"."SPATIAL_INDEX" PARAMETERS ('layer_gtype=multipolygon');
-----
-- Index PK_UTILITYFEATURE
-----
CREATE UNIQUE INDEX "GIS"."PK_UTILITYFEATURE" ON "GIS"."UTILITYFEATURE" ("XFM_ID")
;
-----
-- Index WALL_SIDX
-----
CREATE INDEX "GIS"."WALL_SIDX" ON "GIS"."WALL" ("OGC_GEOMETRY")
INDEXTYPE IS "MDSYS"."SPATIAL_INDEX" PARAMETERS ('layer_gtype=curve');
-----
-- Index PK_WALL
-----
CREATE UNIQUE INDEX "GIS"."PK_WALL" ON "GIS"."WALL" ("XFM_ID") ;
-----
-- Index WASTEWATERNODE_SIDX
-----
CREATE INDEX "GIS"."WASTEWATERNODE_SIDX" ON "GIS"."WASTEWATERNODE" ("OGC_GEOMETRY")
INDEXTYPE IS "MDSYS"."SPATIAL_INDEX" PARAMETERS ('layer_gtype=point');
-----
-- Index PK_WASTEWATERNODE
-----
CREATE UNIQUE INDEX "GIS"."PK_WASTEWATERNODE" ON "GIS"."WASTEWATERNODE" ("XFM_ID")
;
-----
-- Index WASTEWATERSEGMENT_SIDX
-----
CREATE INDEX "GIS"."WASTEWATERSEGMENT_SIDX" ON "GIS"."WASTEWATERSEGMENT"
("OGC_GEOMETRY")
INDEXTYPE IS "MDSYS"."SPATIAL_INDEX" PARAMETERS ('layer_gtype=curve');
-----
-- Index PK_WASTEWATERSEGMENT
-----
CREATE UNIQUE INDEX "GIS"."PK_WASTEWATERSEGMENT" ON "GIS"."WASTEWATERSEGMENT"
("XFM_ID") ;
-----
-- Index WATERCOURSELINE_SIDX
-----
CREATE INDEX "GIS"."WATERCOURSELINE_SIDX" ON "GIS"."WATERCOURSELINE"
("OGC_GEOMETRY")
INDEXTYPE IS "MDSYS"."SPATIAL_INDEX" PARAMETERS ('layer_gtype=curve');
-----
-- Index PK_WATERCOURSELINE
-----
CREATE UNIQUE INDEX "GIS"."PK_WATERCOURSELINE" ON "GIS"."WATERCOURSELINE" ("XFM_ID")
;
-----

```

```

-- Index WATERFEATURE_SIDX
-----
CREATE INDEX "GIS"."WATERFEATURE_SIDX" ON "GIS"."WATERFEATURE" ("OGC_GEOMETRY")
  INDEXTYPE IS "MDSYS"."SPATIAL_INDEX" PARAMETERS ('layer_gtype=polygon');
-----
-- Index PK_WATERFEATURE
-----
CREATE UNIQUE INDEX "GIS"."PK_WATERFEATURE" ON "GIS"."WATERFEATURE" ("XFM_ID") ;
-----
-- Index WATERNODE_SIDX
-----
CREATE INDEX "GIS"."WATERNODE_SIDX" ON "GIS"."WATERNODE" ("OGC_GEOMETRY")
  INDEXTYPE IS "MDSYS"."SPATIAL_INDEX" PARAMETERS ('layer_gtype=point');
-----
-- Index PK_WATERNODE
-----
CREATE UNIQUE INDEX "GIS"."PK_WATERNODE" ON "GIS"."WATERNODE" ("XFM_ID") ;
-----
-- Index WATERSEGMENT_SIDX
-----
CREATE INDEX "GIS"."WATERSEGMENT_SIDX" ON "GIS"."WATERSEGMENT" ("OGC_GEOMETRY")
  INDEXTYPE IS "MDSYS"."SPATIAL_INDEX" PARAMETERS ('layer_gtype=curve');
-----
-- Index PK_WATERSEGMENT
-----
CREATE UNIQUE INDEX "GIS"."PK_WATERSEGMENT" ON "GIS"."WATERSEGMENT" ("XFM_ID") ;
-----
-- Index PK_DOMAIN_BRIDGETYPE
-----
CREATE UNIQUE INDEX "GIS"."PK_DOMAIN_BRIDGETYPE" ON "GIS"."DOMAIN_BRIDGETYPE"
("TYPE") ;
-----
-- Index PK_DOMAIN_COMNDETYPE
-----
CREATE UNIQUE INDEX "GIS"."PK_DOMAIN_COMNDETYPE" ON "GIS"."DOMAIN_COMNDETYPE"
("TYPE") ;
-----
-- Index PK_DOMAIN_COMNETTYPE
-----
CREATE UNIQUE INDEX "GIS"."PK_DOMAIN_COMNETTYPE" ON "GIS"."DOMAIN_COMNETTYPE"
("TYPE") ;
-----
-- Index PK_DOMAIN_COMSEGTYPE
-----
CREATE UNIQUE INDEX "GIS"."PK_DOMAIN_COMSEGTYPE" ON "GIS"."DOMAIN_COMSEGTYPE"
("TYPE") ;
-----
-- Index PK_DOMAIN_CONFLICTRESOL
-----
CREATE UNIQUE INDEX "GIS"."PK_DOMAIN_CONFLICTRESOL" ON "GIS"."DOMAIN_CONFLICTRESOL"
("TYPE") ;
-----
-- Index PK_DOMAIN_CONFLICTTYPE
-----

```

```

CREATE UNIQUE INDEX "GIS"."PK_DOMAIN_CONFLICTTYPE" ON "GIS"."DOMAIN_CONFLICTTYPE"
("TYPE") ;
-----
-- Index PK_DOMAIN_COORDINATESYSTEM
-----
CREATE UNIQUE INDEX "GIS"."PK_DOMAIN_COORDINATESYSTEM" ON
"GIS"."DOMAIN_COORDINATESYSTEM" ("TYPE") ;
-----
-- Index PK_DOMAIN_ELEVATIONCONTOURTYPE
-----
CREATE UNIQUE INDEX "GIS"."PK_DOMAIN_ELEVATIONCONTOURTYPE" ON
"GIS"."DOMAIN_ELEVATIONCONTOURTYPE" ("TYPE") ;
-----
-- Index PK_DOMAIN_ENDETYPE
-----
CREATE UNIQUE INDEX "GIS"."PK_DOMAIN_ENDETYPE" ON "GIS"."DOMAIN_ENDETYPE" ("TYPE")
;
-----
-- Index PK_DOMAIN_ENETTYPE
-----
CREATE UNIQUE INDEX "GIS"."PK_DOMAIN_ENETTYPE" ON "GIS"."DOMAIN_ENETTYPE" ("TYPE")
;
-----
-- Index PK_DOMAIN_ESEGTYPE
-----
CREATE UNIQUE INDEX "GIS"."PK_DOMAIN_ESEGTYPE" ON "GIS"."DOMAIN_ESEGTYPE" ("TYPE")
;
-----
-- Index PK_DOMAIN_EXTERNALINTERESTTYPE
-----
CREATE UNIQUE INDEX "GIS"."PK_DOMAIN_EXTERNALINTERESTTYPE" ON
"GIS"."DOMAIN_EXTERNALINTERESTTYPE" ("TYPE") ;
-----
-- Index PK_DOMAIN_FENCEUSETYPE
-----
CREATE UNIQUE INDEX "GIS"."PK_DOMAIN_FENCEUSETYPE" ON "GIS"."DOMAIN_FENCEUSETYPE"
("TYPE") ;
-----
-- Index PK_DOMAIN_FITTYPE
-----
CREATE UNIQUE INDEX "GIS"."PK_DOMAIN_FITTYPE" ON "GIS"."DOMAIN_FITTYPE" ("TYPE") ;
-----
-- Index PK DOMAIN GASNDETYPE
-----
CREATE UNIQUE INDEX "GIS"."PK_DOMAIN_GASNDETYPE" ON "GIS"."DOMAIN_GASNDETYPE"
("TYPE") ;
-----
-- Index PK_DOMAIN_GASNETTYPE
-----
CREATE UNIQUE INDEX "GIS"."PK_DOMAIN_GASNETTYPE" ON "GIS"."DOMAIN_GASNETTYPE"
("TYPE") ;
-----
-- Index PK_DOMAIN_GASSEGETYPE
-----
CREATE UNIQUE INDEX "GIS"."PK_DOMAIN_GASSEGETYPE" ON "GIS"."DOMAIN_GASSEGETYPE"
("TYPE") ;

```

```

-----
-- Index PK_DOMAIN_GSIP_LENGTHUOM
-----
CREATE UNIQUE INDEX "GIS"."PK_DOMAIN_GSIP_LENGTHUOM" ON
"GIS"."DOMAIN_GSIP_LENGTHUOM" ("TYPE") ;
-----
-- Index PK_DOMAIN_HORIZONTALDATUMTYPE
-----
CREATE UNIQUE INDEX "GIS"."PK_DOMAIN_HORIZONTALDATUMTYPE" ON
"GIS"."DOMAIN_HORIZONTALDATUMTYPE" ("TYPE") ;
-----
-- Index PK_DOMAIN_MONUMENTPOINTTYPE
-----
CREATE UNIQUE INDEX "GIS"."PK_DOMAIN_MONUMENTPOINTTYPE" ON
"GIS"."DOMAIN_MONUMENTPOINTTYPE" ("TYPE") ;
-----
-- Index PK_DOMAIN_NDESHPTYPE
-----
CREATE UNIQUE INDEX "GIS"."PK_DOMAIN_NDESHPTYPE" ON "GIS"."DOMAIN_NDESHPTYPE"
("TYPE") ;
-----
-- Index PK_DOMAIN_NETWORKSUBTYPE
-----
CREATE UNIQUE INDEX "GIS"."PK_DOMAIN_NETWORKSUBTYPE" ON
"GIS"."DOMAIN_NETWORKSUBTYPE" ("TYPE") ;
-----
-- Index PK_DOMAIN_NETWORKTYPE
-----
CREATE UNIQUE INDEX "GIS"."PK_DOMAIN_NETWORKTYPE" ON "GIS"."DOMAIN_NETWORKTYPE"
("TYPE") ;
-----
-- Index PK_DOMAIN_PAVEMENTSE
-----
CREATE UNIQUE INDEX "GIS"."PK_DOMAIN_PAVEMENTSE" ON "GIS"."DOMAIN_PAVEMENTSECTIONT"
("TYPE") ;
-----
-- Index PK_DOMAIN_PIPEMATERIAL
-----
CREATE UNIQUE INDEX "GIS"."PK_DOMAIN_PIPEMATERIAL" ON "GIS"."DOMAIN_PIPEMATERIAL"
("TYPE") ;
-----
-- Index PK_DOMAIN_POLNETTYPE
-----
CREATE UNIQUE INDEX "GIS"."PK_DOMAIN_POLNETTYPE" ON "GIS"."DOMAIN_POLNETTYPE"
("TYPE") ;
-----
-- Index PK_DOMAIN_POLNDETYPE
-----
CREATE UNIQUE INDEX "GIS"."PK_DOMAIN_POLNDETYPE" ON "GIS"."DOMAIN_POLNDETYPE"
("TYPE") ;
-----
-- Index PK_DOMAIN_POLSEGTYPE
-----
CREATE UNIQUE INDEX "GIS"."PK_DOMAIN_POLSEGTYPE" ON "GIS"."DOMAIN_POLSEGTYPE"
("TYPE") ;
-----

```



```

-- Index PK_DOMAIN_RAILCONSTRUCTIONTYPE
-----
CREATE UNIQUE INDEX "GIS"."PK_DOMAIN_RAILCONSTRUCTIONTYPE" ON
"GIS"."DOMAIN_RAILCONSTRUCTIONTYPE" ("TYPE") ;
-----
-- Index PK_DOMAIN_RECREATIONAREATYPE
-----
CREATE UNIQUE INDEX "GIS"."PK_DOMAIN_RECREATIONAREATYPE" ON
"GIS"."DOMAIN_RECREATIONAREATYPE" ("TYPE") ;
-----
-- Index PK_DOMAIN_SEGSHPTYPE
-----
CREATE UNIQUE INDEX "GIS"."PK_DOMAIN_SEGSHPTYPE" ON "GIS"."DOMAIN_SEGSHPTYPE"
("TYPE") ;
-----
-- Index PK_DOMAIN_SEGTYPE
-----
CREATE UNIQUE INDEX "GIS"."PK_DOMAIN_SEGTYPE" ON "GIS"."DOMAIN_SEGTYPE" ("TYPE") ;
-----
-- Index PK_DOMAIN_SIGNTYPE
-----
CREATE UNIQUE INDEX "GIS"."PK_DOMAIN_SIGNTYPE" ON "GIS"."DOMAIN_SIGNTYPE" ("TYPE")
;
-----
-- Index PK_DOMAIN_STRUCTURALCONDITION
-----
CREATE UNIQUE INDEX "GIS"."PK_DOMAIN_STRUCTURALCONDITION" ON
"GIS"."DOMAIN_STRUCTURALCONDITION" ("TYPE") ;
-----
-- Index PK_DOMAIN_STRUCTUREMATERIAL
-----
CREATE UNIQUE INDEX "GIS"."PK_DOMAIN_STRUCTUREMATERIAL" ON
"GIS"."DOMAIN_STRUCTUREMATERIAL" ("TYPE") ;
-----
-- Index PK_DOMAIN_SURVEYMETHOD
-----
CREATE UNIQUE INDEX "GIS"."PK_DOMAIN_SURVEYMETHOD" ON "GIS"."DOMAIN_SURVEYMETHOD"
("TYPE") ;
-----
-- Index PK_DOMAIN_SURVEYSOURCETYPE
-----
CREATE UNIQUE INDEX "GIS"."PK_DOMAIN_SURVEYSOURCETYPE" ON
"GIS"."DOMAIN_SURVEYSOURCETYPE" ("TYPE") ;
-----
-- Index PK_DOMAIN_SURVEYTYPE
-----
CREATE UNIQUE INDEX "GIS"."PK_DOMAIN_SURVEYTYPE" ON "GIS"."DOMAIN_SURVEYTYPE"
("TYPE") ;
-----
-- Index PK_DOMAIN_THMNETTYPE
-----
CREATE UNIQUE INDEX "GIS"."PK_DOMAIN_THMNETTYPE" ON "GIS"."DOMAIN_THMNETTYPE"
("TYPE") ;
-----
-- Index PK_DOMAIN_THMNODTYPE
-----

```

```

CREATE UNIQUE INDEX "GIS"."PK_DOMAIN_THMNODTYPE" ON "GIS"."DOMAIN_THMNODTYPE"
("TYPE") ;
-----
-- Index PK_DOMAIN_THMSEGTYPE
-----
CREATE UNIQUE INDEX "GIS"."PK_DOMAIN_THMSEGTYPE" ON "GIS"."DOMAIN_THMSEGTYPE"
("TYPE") ;
-----
-- Index PK_DOMAIN_TOWERUSETYPE
-----
CREATE UNIQUE INDEX "GIS"."PK_DOMAIN_TOWERUSETYPE" ON "GIS"."DOMAIN_TOWERUSETYPE"
("TYPE") ;
-----
-- Index PK_DOMAIN_TRANSTUNNELTYPE
-----
CREATE UNIQUE INDEX "GIS"."PK_DOMAIN_TRANSTUNNELTYPE" ON
"GIS"."DOMAIN_TRANSTUNNELTYPE" ("TYPE") ;
-----
-- Index PK_DOMAIN_UTILITYDATAQUALITY
-----
CREATE UNIQUE INDEX "GIS"."PK_DOMAIN_UTILITYDATAQUALITY" ON
"GIS"."DOMAIN_UTILITYDATAQUALITY" ("TYPE") ;
-----
-- Index PK_DOMAIN_UTILITYFEATURET
-----
CREATE UNIQUE INDEX "GIS"."PK_DOMAIN_UTILITYFEATURET" ON
"GIS"."DOMAIN_UTILITYFEATURET" ("TYPE") ;
-----
-- Index PK_DOMAIN_UTILITYINVESTATIONLE
-----
CREATE UNIQUE INDEX "GIS"."PK_DOMAIN_UTILITYINVESTATIONLE" ON
"GIS"."DOMAIN_UTILITYINVESTATIONLEVEL" ("TYPE") ;
-----
-- Index PK_DOMAIN_UTILITYRESOLUTIONS
-----
CREATE UNIQUE INDEX "GIS"."PK_DOMAIN_UTILITYRESOLUTIONS" ON
"GIS"."DOMAIN_UTILITYRESOLUTIONS" ("TYPE") ;
-----
-- Index PK_DOMAIN_UTILITYRESOLUTIONSTA
-----
CREATE UNIQUE INDEX "GIS"."PK_DOMAIN_UTILITYRESOLUTIONSTA" ON
"GIS"."DOMAIN_UTILITYRESOLUTIONSTATUS" ("TYPE") ;
-----
-- Index PK_DOMAIN_UTLNDETYPE
-----
CREATE UNIQUE INDEX "GIS"."PK_DOMAIN_UTLNDETYPE" ON "GIS"."DOMAIN_UTLNDETYPE"
("TYPE") ;
-----
-- Index PK_DOMAIN_UTILOPSTAT
-----
CREATE UNIQUE INDEX "GIS"."PK_DOMAIN_UTILOPSTAT" ON "GIS"."DOMAIN_UTILOPSTAT"
("TYPE") ;
-----
-- Index PK_DOMAIN_VERTICALDATUMTYPE
-----

```

```

CREATE UNIQUE INDEX "GIS"."PK_DOMAIN_VERTICALDATUMTYPE" ON
"GIS"."DOMAIN_VERTICALDATUMTYPE" ("TYPE") ;
-----
-- Index PK_DOMAIN_VOLTYPE
-----
CREATE UNIQUE INDEX "GIS"."PK_DOMAIN_VOLTYPE" ON "GIS"."DOMAIN_VOLTYPE" ("TYPE") ;
-----
-- Index PK_DOMAIN_WALLTYPE
-----
CREATE UNIQUE INDEX "GIS"."PK_DOMAIN_WALLTYPE" ON "GIS"."DOMAIN_WALLTYPE" ("TYPE")
;
-----
-- Index PK_DOMAIN_WATERCOURSEELEMENTTY
-----
CREATE UNIQUE INDEX "GIS"."PK_DOMAIN_WATERCOURSEELEMENTTY" ON
"GIS"."DOMAIN_WATERCOURSEELEMENTTY" ("TYPE") ;
-----
-- Index PK_DOMAIN_WTRNDETYPE
-----
CREATE UNIQUE INDEX "GIS"."PK_DOMAIN_WTRNDETYPE" ON "GIS"."DOMAIN_WTRNDETYPE"
("TYPE") ;
-----
-- Index PK_DOMAIN_WTRNETTYPE
-----
CREATE UNIQUE INDEX "GIS"."PK_DOMAIN_WTRNETTYPE" ON "GIS"."DOMAIN_WTRNETTYPE"
("TYPE") ;
-----
-- Index PK_DOMAIN_WTRSEGTYPE
-----
CREATE UNIQUE INDEX "GIS"."PK_DOMAIN_WTRSEGTYPE" ON "GIS"."DOMAIN_WTRSEGTYPE"
("TYPE") ;
-----
-- Index PK_DOMAIN_WWNDETYPE
-----
CREATE UNIQUE INDEX "GIS"."PK_DOMAIN_WWNDETYPE" ON "GIS"."DOMAIN_WWNDETYPE" ("TYPE")
;
-----
-- Index PK_DOMAIN_WWNETTYPE
-----
CREATE UNIQUE INDEX "GIS"."PK_DOMAIN_WWNETTYPE" ON "GIS"."DOMAIN_WWNETTYPE" ("TYPE")
;
-----
-- Index PK DOMAIN WWSEGTYPE
-----
CREATE UNIQUE INDEX "GIS"."PK_DOMAIN_WWSEGTYPE" ON "GIS"."DOMAIN_WWSEGTYPE" ("TYPE")
;
-----
-- Constraints
-----
-----
-- Constraints for Table SIGN
-----
ALTER TABLE "GIS"."SIGN" ADD CONSTRAINT "PK_SIGN" PRIMARY KEY ("XFM_ID") ENABLE;
-----
-- Constraints for Table CONSTRUCTIONLINE

```

```

-----
ALTER TABLE "GIS"."CONSTRUCTIONLINE" ADD CONSTRAINT "PK_CONSTRUCTIONLINE" PRIMARY KEY
("XFM_ID") ENABLE;
-----
-- Constraints for Table DOMAIN_WWNETTYPE
-----
ALTER TABLE "GIS"."DOMAIN_WWNETTYPE" ADD CONSTRAINT "PK_DOMAIN_WWNETTYPE" PRIMARY KEY
("TYPE") ENABLE;
ALTER TABLE "GIS"."DOMAIN_WWNETTYPE" MODIFY ("TYPE" NOT NULL ENABLE);
-----
-- Constraints for Table DOMAIN_ELEVATIONCONTOURTYPE
-----
ALTER TABLE "GIS"."DOMAIN_ELEVATIONCONTOURTYPE" ADD CONSTRAINT
"PK_DOMAIN_ELEVATIONCONTOURTYPE" PRIMARY KEY ("TYPE") ENABLE;
ALTER TABLE "GIS"."DOMAIN_ELEVATIONCONTOURTYPE" MODIFY ("TYPE" NOT NULL ENABLE);
-----
-- Constraints for Table FENCE
-----
ALTER TABLE "GIS"."FENCE" ADD CONSTRAINT "PK_FENCE" PRIMARY KEY ("XFM_ID") ENABLE;
-----
-- Constraints for Table WATERCOURSELINE
-----
ALTER TABLE "GIS"."WATERCOURSELINE" ADD CONSTRAINT "PK_WATERCOURSELINE" PRIMARY KEY
("XFM_ID") ENABLE;
-----
-- Constraints for Table ROADPATH
-----
ALTER TABLE "GIS"."ROADPATH" ADD CONSTRAINT "PK_ROADPATH" PRIMARY KEY ("XFM_ID")
ENABLE;
-----
-- Constraints for Table BRIDGE
-----
ALTER TABLE "GIS"."BRIDGE" ADD CONSTRAINT "PK_BRIDGE" PRIMARY KEY ("XFM_ID") ENABLE;
-----
-- Constraints for Table TOWER
-----
ALTER TABLE "GIS"."TOWER" ADD CONSTRAINT "PK_TOWER" PRIMARY KEY ("XFM_ID") ENABLE;
-----
-- Constraints for Table THERMALSEGMENT
-----
ALTER TABLE "GIS"."THERMALSEGMENT" ADD CONSTRAINT "PK_THERMALSEGMENT" PRIMARY KEY
("XFM_ID") ENABLE;
-----
-- Constraints for Table DOMAIN_ENETTYPE
-----
ALTER TABLE "GIS"."DOMAIN_ENETTYPE" ADD CONSTRAINT "PK_DOMAIN_ENETTYPE" PRIMARY KEY
("TYPE") ENABLE;
ALTER TABLE "GIS"."DOMAIN_ENETTYPE" MODIFY ("TYPE" NOT NULL ENABLE);
-----
-- Constraints for Table DOMAIN_THMNETTYPE
-----
ALTER TABLE "GIS"."DOMAIN_THMNETTYPE" ADD CONSTRAINT "PK_DOMAIN_THMNETTYPE" PRIMARY
KEY ("TYPE") ENABLE;
ALTER TABLE "GIS"."DOMAIN_THMNETTYPE" MODIFY ("TYPE" NOT NULL ENABLE);
-----
-- Constraints for Table COMMUNICATIONSEGMENT

```

```

-----
ALTER TABLE "GIS"."COMMUNICATIONSEGMENT" ADD CONSTRAINT "PK_COMMUNICATIONSEGMENT"
PRIMARY KEY ("XFM_ID") ENABLE;
-----
-- Constraints for Table DOMAIN_COORDINATESYSTEM
-----
ALTER TABLE "GIS"."DOMAIN_COORDINATESYSTEM" ADD CONSTRAINT
"PK_DOMAIN_COORDINATESYSTEM" PRIMARY KEY ("TYPE") ENABLE;
ALTER TABLE "GIS"."DOMAIN_COORDINATESYSTEM" MODIFY ("TYPE" NOT NULL ENABLE);
-----
-- Constraints for Table DOMAIN_SURVEYTYPE
-----
ALTER TABLE "GIS"."DOMAIN_SURVEYTYPE" ADD CONSTRAINT "PK_DOMAIN_SURVEYTYPE" PRIMARY
KEY ("TYPE") ENABLE;
ALTER TABLE "GIS"."DOMAIN_SURVEYTYPE" MODIFY ("TYPE" NOT NULL ENABLE);
-----
-- Constraints for Table STRUCTURE
-----
ALTER TABLE "GIS"."STRUCTURE" ADD CONSTRAINT "PK_STRUCTURE" PRIMARY KEY ("XFM_ID")
ENABLE;
-----
-- Constraints for Table LANDPARCEL
-----
ALTER TABLE "GIS"."LANDPARCEL" ADD CONSTRAINT "PK_LANDPARCEL" PRIMARY KEY ("XFM_ID")
ENABLE;
-----
-- Constraints for Table DOMAIN_WWNDETYPE
-----
ALTER TABLE "GIS"."DOMAIN_WWNDETYPE" ADD CONSTRAINT "PK_DOMAIN_WWNDETYPE" PRIMARY KEY
("TYPE") ENABLE;
ALTER TABLE "GIS"."DOMAIN_WWNDETYPE" MODIFY ("TYPE" NOT NULL ENABLE);
-----
-- Constraints for Table BUILDING
-----
ALTER TABLE "GIS"."BUILDING" ADD CONSTRAINT "PK_BUILDING" PRIMARY KEY ("XFM_ID")
ENABLE;
-----
-- Constraints for Table ELECTRICALNODE
-----
ALTER TABLE "GIS"."ELECTRICALNODE" ADD CONSTRAINT "PK_ELECTRICALNODE" PRIMARY KEY
("XFM_ID") ENABLE;
-----
-- Constraints for Table DOMAIN_SEGTYPE
-----
ALTER TABLE "GIS"."DOMAIN_SEGTYPE" ADD CONSTRAINT "PK_DOMAIN_SEGTYPE" PRIMARY KEY
("TYPE") ENABLE;
ALTER TABLE "GIS"."DOMAIN_SEGTYPE" MODIFY ("TYPE" NOT NULL ENABLE);
-----
-- Constraints for Table GUARDRAIL
-----
ALTER TABLE "GIS"."GUARDRAIL" ADD CONSTRAINT "PK_GUARDRAIL" PRIMARY KEY ("XFM_ID")
ENABLE;
-----
-- Constraints for Table DOMAIN_WATERCOURSEELEMENTTYPE
-----

```

```

ALTER TABLE "GIS"."DOMAIN_WATERCOURSEELEMENTTYPE" ADD CONSTRAINT
"PK_DOMAIN_WATERCOURSEELEMENTTY" PRIMARY KEY ("TYPE") ENABLE;
ALTER TABLE "GIS"."DOMAIN_WATERCOURSEELEMENTTYPE" MODIFY ("TYPE" NOT NULL ENABLE);
-----
-- Constraints for Table DOMAIN_GASSEGTYPE
-----
ALTER TABLE "GIS"."DOMAIN_GASSEGTYPE" ADD CONSTRAINT "PK_DOMAIN_GASSEGTYPE" PRIMARY
KEY ("TYPE") ENABLE;
ALTER TABLE "GIS"."DOMAIN_GASSEGTYPE" MODIFY ("TYPE" NOT NULL ENABLE);
-----
-- Constraints for Table GASNODE
-----
ALTER TABLE "GIS"."GASNODE" ADD CONSTRAINT "PK_GASNODE" PRIMARY KEY ("XFM_ID") ENABLE;
-----
-- Constraints for Table GASSEGMENT
-----
ALTER TABLE "GIS"."GASSEGMENT" ADD CONSTRAINT "PK_GASSEGMENT" PRIMARY KEY ("XFM_ID")
ENABLE;
-----
-- Constraints for Table DOMAIN_TRANSTUNNELTYPE
-----
ALTER TABLE "GIS"."DOMAIN_TRANSTUNNELTYPE" ADD CONSTRAINT
"PK_DOMAIN_TRANSTUNNELTYPE" PRIMARY KEY ("TYPE") ENABLE;
ALTER TABLE "GIS"."DOMAIN_TRANSTUNNELTYPE" MODIFY ("TYPE" NOT NULL ENABLE);
-----
-- Constraints for Table DOMAIN_STRUCTUREMATERIAL
-----
ALTER TABLE "GIS"."DOMAIN_STRUCTUREMATERIAL" ADD CONSTRAINT
"PK_DOMAIN_STRUCTUREMATERIAL" PRIMARY KEY ("TYPE") ENABLE;
ALTER TABLE "GIS"."DOMAIN_STRUCTUREMATERIAL" MODIFY ("TYPE" NOT NULL ENABLE);
-----
-- Constraints for Table DOMAIN_GASNETTYPE
-----
ALTER TABLE "GIS"."DOMAIN_GASNETTYPE" ADD CONSTRAINT "PK_DOMAIN_GASNETTYPE" PRIMARY
KEY ("TYPE") ENABLE;
ALTER TABLE "GIS"."DOMAIN_GASNETTYPE" MODIFY ("TYPE" NOT NULL ENABLE);
-----
-- Constraints for Table DOMAIN_MONUMENTPOINTTYPE
-----
ALTER TABLE "GIS"."DOMAIN_MONUMENTPOINTTYPE" ADD CONSTRAINT
"PK_DOMAIN_MONUMENTPOINTTYPE" PRIMARY KEY ("TYPE") ENABLE;
ALTER TABLE "GIS"."DOMAIN_MONUMENTPOINTTYPE" MODIFY ("TYPE" NOT NULL ENABLE);
-----
-- Constraints for Table DOMAIN_FITTYPE
-----
ALTER TABLE "GIS"."DOMAIN_FITTYPE" ADD CONSTRAINT "PK_DOMAIN_FITTYPE" PRIMARY KEY
("TYPE") ENABLE;
ALTER TABLE "GIS"."DOMAIN_FITTYPE" MODIFY ("TYPE" NOT NULL ENABLE);
-----
-- Constraints for Table SURVEYPOINT
-----
ALTER TABLE "GIS"."SURVEYPOINT" ADD CONSTRAINT "PK_SURVEYPOINT" PRIMARY KEY
("XFM_ID") ENABLE;
-----
-- Constraints for Table DOMAIN_SEGSHPTYPE
-----

```

```

ALTER TABLE "GIS"."DOMAIN_SEGSHPTYPE" ADD CONSTRAINT "PK_DOMAIN_SEGSHPTYPE" PRIMARY
KEY ("TYPE") ENABLE;
ALTER TABLE "GIS"."DOMAIN_SEGSHPTYPE" MODIFY ("TYPE" NOT NULL ENABLE);
-----
-- Constraints for Table UTILITYFEATURE
-----
ALTER TABLE "GIS"."UTILITYFEATURE" ADD CONSTRAINT "PK_UTILITYFEATURE" PRIMARY KEY
("XFM_ID") ENABLE;
-----
-- Constraints for Table DOMAIN_WTRSEGTYPE
-----
ALTER TABLE "GIS"."DOMAIN_WTRSEGTYPE" ADD CONSTRAINT "PK_DOMAIN_WTRSEGTYPE" PRIMARY
KEY ("TYPE") ENABLE;
ALTER TABLE "GIS"."DOMAIN_WTRSEGTYPE" MODIFY ("TYPE" NOT NULL ENABLE);
-----
-- Constraints for Table DOMAIN_COMNDETYPE
-----
ALTER TABLE "GIS"."DOMAIN_COMNDETYPE" ADD CONSTRAINT "PK_DOMAIN_COMNDETYPE" PRIMARY
KEY ("TYPE") ENABLE;
ALTER TABLE "GIS"."DOMAIN_COMNDETYPE" MODIFY ("TYPE" NOT NULL ENABLE);
-----
-- Constraints for Table DOMAIN_SURVEYSOURCETYPE
-----
ALTER TABLE "GIS"."DOMAIN_SURVEYSOURCETYPE" ADD CONSTRAINT
"PK_DOMAIN_SURVEYSOURCETYPE" PRIMARY KEY ("TYPE") ENABLE;
ALTER TABLE "GIS"."DOMAIN_SURVEYSOURCETYPE" MODIFY ("TYPE" NOT NULL ENABLE);
-----
-- Constraints for Table WATERFEATURE
-----
ALTER TABLE "GIS"."WATERFEATURE" ADD CONSTRAINT "PK_WATERFEATURE" PRIMARY KEY
("XFM_ID") ENABLE;
-----
-- Constraints for Table DOMAIN_WWSEGTYPE
-----
ALTER TABLE "GIS"."DOMAIN_WWSEGTYPE" ADD CONSTRAINT "PK_DOMAIN_WWSEGTYPE" PRIMARY KEY
("TYPE") ENABLE;
ALTER TABLE "GIS"."DOMAIN_WWSEGTYPE" MODIFY ("TYPE" NOT NULL ENABLE);
-----
-- Constraints for Table SITE
-----
ALTER TABLE "GIS"."SITE" ADD CONSTRAINT "PK_SITE" PRIMARY KEY ("XFM_ID") ENABLE;
-----
-- Constraints for Table DOMAIN_ESEGTYPE
-----
ALTER TABLE "GIS"."DOMAIN_ESEGTYPE" ADD CONSTRAINT "PK_DOMAIN_ESEGTYPE" PRIMARY KEY
("TYPE") ENABLE;
ALTER TABLE "GIS"."DOMAIN_ESEGTYPE" MODIFY ("TYPE" NOT NULL ENABLE);
-----
-- Constraints for Table EXTERNALPROPERTYINTEREST
-----
ALTER TABLE "GIS"."EXTERNALPROPERTYINTEREST" ADD CONSTRAINT
"PK_EXTERNALPROPERTYINTEREST" PRIMARY KEY ("XFM_ID") ENABLE;
-----
-- Constraints for Table DOMAIN_HORIZONTALDATUMTYPE
-----

```

```

ALTER TABLE "GIS"."DOMAIN_HORIZONTALDATUMTYPE" ADD CONSTRAINT
"PK_DOMAIN_HORIZONTALDATUMTYPE" PRIMARY KEY ("TYPE") ENABLE;
ALTER TABLE "GIS"."DOMAIN_HORIZONTALDATUMTYPE" MODIFY ("TYPE" NOT NULL ENABLE);
-----
-- Constraints for Table CONFLICTNODE
-----
ALTER TABLE "GIS"."CONFLICTNODE" ADD CONSTRAINT "PK_CONFLICTNODE" PRIMARY KEY
("XFM_ID") ENABLE;
-----
-- Constraints for Table DOMAIN_SIGNTYPE
-----
ALTER TABLE "GIS"."DOMAIN_SIGNTYPE" ADD CONSTRAINT "PK_DOMAIN_SIGNTYPE" PRIMARY KEY
("TYPE") ENABLE;
ALTER TABLE "GIS"."DOMAIN_SIGNTYPE" MODIFY ("TYPE" NOT NULL ENABLE);
-----
-- Constraints for Table DOMAIN_UTILITYDATAQUALITY
-----
ALTER TABLE "GIS"."DOMAIN_UTILITYDATAQUALITY" ADD CONSTRAINT
"PK_DOMAIN_UTILITYDATAQUALITY" PRIMARY KEY ("TYPE") ENABLE;
ALTER TABLE "GIS"."DOMAIN_UTILITYDATAQUALITY" MODIFY ("TYPE" NOT NULL ENABLE);
-----
-- Constraints for Table ELEVATIONCONTOUR
-----
ALTER TABLE "GIS"."ELEVATIONCONTOUR" ADD CONSTRAINT "PK_ELEVATIONCONTOUR" PRIMARY KEY
("XFM_ID") ENABLE;
-----
-- Constraints for Table SURVEYJOB
-----
ALTER TABLE "GIS"."SURVEYJOB" ADD CONSTRAINT "PK_SURVEYJOB" PRIMARY KEY ("XFM_ID")
ENABLE;
-----
-- Constraints for Table RESTRICTEDAREA
-----
ALTER TABLE "GIS"."RESTRICTEDAREA" ADD CONSTRAINT "PK_RESTRICTEDAREA" PRIMARY KEY
("XFM_ID") ENABLE;
-----
-- Constraints for Table RECREATIONAREA
-----
ALTER TABLE "GIS"."RECREATIONAREA" ADD CONSTRAINT "PK_RECREATIONAREA" PRIMARY KEY
("XFM_ID") ENABLE;
-----
-- Constraints for Table DOMAIN_GSIP_LENGTHUOM
-----
ALTER TABLE "GIS"."DOMAIN_GSIP_LENGTHUOM" ADD CONSTRAINT "PK_DOMAIN_GSIP_LENGTHUOM"
PRIMARY KEY ("TYPE") ENABLE;
ALTER TABLE "GIS"."DOMAIN_GSIP_LENGTHUOM" MODIFY ("TYPE" NOT NULL ENABLE);
-----
-- Constraints for Table INSTALLATION
-----
ALTER TABLE "GIS"."INSTALLATION" ADD CONSTRAINT "PK_INSTALLATION" PRIMARY KEY
("XFM_ID") ENABLE;
-----
-- Constraints for Table DOMAIN_CONFLICTRESOL
-----
ALTER TABLE "GIS"."DOMAIN_CONFLICTRESOL" ADD CONSTRAINT "PK_DOMAIN_CONFLICTRESOL"
PRIMARY KEY ("TYPE") ENABLE;

```



```

ALTER TABLE "GIS"."DOMAIN_CONFLICTRESOL" MODIFY ("TYPE" NOT NULL ENABLE);
-----
-- Constraints for Table DOMAIN_THMNODTYPE
-----
ALTER TABLE "GIS"."DOMAIN_THMNODTYPE" ADD CONSTRAINT "PK_DOMAIN_THMNODTYPE" PRIMARY
KEY ("TYPE") ENABLE;
ALTER TABLE "GIS"."DOMAIN_THMNODTYPE" MODIFY ("TYPE" NOT NULL ENABLE);
-----
-- Constraints for Table CONTROLMONUMENTPOINT
-----
ALTER TABLE "GIS"."CONTROLMONUMENTPOINT" ADD CONSTRAINT "PK_CONTROLMONUMENTPOINT"
PRIMARY KEY ("XFM_ID") ENABLE;
-----
-- Constraints for Table WASTEWATERNODE
-----
ALTER TABLE "GIS"."WASTEWATERNODE" ADD CONSTRAINT "PK_WASTEWATERNODE" PRIMARY KEY
("XFM_ID") ENABLE;
-----
-- Constraints for Table TRANSPORTATIONTUNNEL
-----
ALTER TABLE "GIS"."TRANSPORTATIONTUNNEL" ADD CONSTRAINT "PK_TRANSPORTATIONTUNNEL"
PRIMARY KEY ("XFM_ID") ENABLE;
-----
-- Constraints for Table DOMAIN_WALLTYPE
-----
ALTER TABLE "GIS"."DOMAIN_WALLTYPE" ADD CONSTRAINT "PK_DOMAIN_WALLTYPE" PRIMARY KEY
("TYPE") ENABLE;
ALTER TABLE "GIS"."DOMAIN_WALLTYPE" MODIFY ("TYPE" NOT NULL ENABLE);
-----
-- Constraints for Table DOMAIN_VERTICALDATUMTYPE
-----
ALTER TABLE "GIS"."DOMAIN_VERTICALDATUMTYPE" ADD CONSTRAINT
"PK_DOMAIN_VERTICALDATUMTYPE" PRIMARY KEY ("TYPE") ENABLE;
ALTER TABLE "GIS"."DOMAIN_VERTICALDATUMTYPE" MODIFY ("TYPE" NOT NULL ENABLE);
-----
-- Constraints for Table DOMAIN_UTILOPSTAT
-----
ALTER TABLE "GIS"."DOMAIN_UTILOPSTAT" ADD CONSTRAINT "PK_DOMAIN_UTILOPSTAT" PRIMARY
KEY ("TYPE") ENABLE;
ALTER TABLE "GIS"."DOMAIN_UTILOPSTAT" MODIFY ("TYPE" NOT NULL ENABLE);
-----
-- Constraints for Table POLSEGMENT
-----
ALTER TABLE "GIS"."POLSEGMENT" ADD CONSTRAINT "PK_POLSEGMENT" PRIMARY KEY ("XFM_ID")
ENABLE;
-----
-- Constraints for Table DOMAIN_UTILITYINVESTATIONLEVEL
-----
ALTER TABLE "GIS"."DOMAIN_UTILITYINVESTATIONLEVEL" ADD CONSTRAINT
"PK_DOMAIN_UTILITYINVESTATIONLE" PRIMARY KEY ("TYPE") ENABLE;
ALTER TABLE "GIS"."DOMAIN_UTILITYINVESTATIONLEVEL" MODIFY ("TYPE" NOT NULL ENABLE);
-----
-- Constraints for Table THERMALNODE
-----
ALTER TABLE "GIS"."THERMALNODE" ADD CONSTRAINT "PK_THERMALNODE" PRIMARY KEY
("XFM_ID") ENABLE;

```

```

-----
-- Constraints for Table DOMAIN_RAILCONSTRUCTIONTYPE
-----
ALTER TABLE "GIS"."DOMAIN_RAILCONSTRUCTIONTYPE" ADD CONSTRAINT
"PK_DOMAIN_RAILCONSTRUCTIONTYPE" PRIMARY KEY ("TYPE") ENABLE;
ALTER TABLE "GIS"."DOMAIN_RAILCONSTRUCTIONTYPE" MODIFY ("TYPE" NOT NULL ENABLE);
-----
-- Constraints for Table DOMAIN_WTRNETTYPE
-----
ALTER TABLE "GIS"."DOMAIN_WTRNETTYPE" ADD CONSTRAINT "PK_DOMAIN_WTRNETTYPE" PRIMARY
KEY ("TYPE") ENABLE;
ALTER TABLE "GIS"."DOMAIN_WTRNETTYPE" MODIFY ("TYPE" NOT NULL ENABLE);
-----
-- Constraints for Table ELECCONDUITBANKSEGMENT
-----
ALTER TABLE "GIS"."ELECCONDUITBANKSEGMENT" ADD CONSTRAINT
"PK_ELECCONDUITBANKSEGMENT" PRIMARY KEY ("XFM_ID") ENABLE;
-----
-- Constraints for Table DOMAIN_SURVEYMETHOD
-----
ALTER TABLE "GIS"."DOMAIN_SURVEYMETHOD" ADD CONSTRAINT "PK_DOMAIN_SURVEYMETHOD"
PRIMARY KEY ("TYPE") ENABLE;
ALTER TABLE "GIS"."DOMAIN_SURVEYMETHOD" MODIFY ("TYPE" NOT NULL ENABLE);
-----
-- Constraints for Table DOMAIN_PIPEMATERIAL
-----
ALTER TABLE "GIS"."DOMAIN_PIPEMATERIAL" ADD CONSTRAINT "PK_DOMAIN_PIPEMATERIAL"
PRIMARY KEY ("TYPE") ENABLE;
ALTER TABLE "GIS"."DOMAIN_PIPEMATERIAL" MODIFY ("TYPE" NOT NULL ENABLE);
-----
-- Constraints for Table DOMAIN_THMSEGTYPE
-----
ALTER TABLE "GIS"."DOMAIN_THMSEGTYPE" ADD CONSTRAINT "PK_DOMAIN_THMSEGTYPE" PRIMARY
KEY ("TYPE") ENABLE;
ALTER TABLE "GIS"."DOMAIN_THMSEGTYPE" MODIFY ("TYPE" NOT NULL ENABLE);
-----
-- Constraints for Table WATERNODE
-----
ALTER TABLE "GIS"."WATERNODE" ADD CONSTRAINT "PK_WATERNODE" PRIMARY KEY ("XFM_ID")
ENABLE;
-----
-- Constraints for Table DOMAIN_UTILITYFEATURET
-----
ALTER TABLE "GIS"."DOMAIN_UTILITYFEATURET" ADD CONSTRAINT
"PK_DOMAIN_UTILITYFEATURET" PRIMARY KEY ("TYPE") ENABLE;
ALTER TABLE "GIS"."DOMAIN_UTILITYFEATURET" MODIFY ("TYPE" NOT NULL ENABLE);
-----
-- Constraints for Table PROJECTREFERENCE
-----
ALTER TABLE "GIS"."PROJECTREFERENCE" ADD CONSTRAINT "PK_PROJECTREFERENCE" PRIMARY KEY
("XFM_ID") ENABLE;
-----
-- Constraints for Table DOTPERMIT
-----
ALTER TABLE "GIS"."DOTPERMIT" ADD CONSTRAINT "PK_DOTPERMIT" PRIMARY KEY ("XFM_ID")
ENABLE;

```

```

-----
-- Constraints for Table DOMAIN_VOLTYPE
-----
ALTER TABLE "GIS"."DOMAIN_VOLTYPE" ADD CONSTRAINT "PK_DOMAIN_VOLTYPE" PRIMARY KEY
("TYPE") ENABLE;
ALTER TABLE "GIS"."DOMAIN_VOLTYPE" MODIFY ("TYPE" NOT NULL ENABLE);
-----
-- Constraints for Table DOMAIN_WTRNDETYPE
-----
ALTER TABLE "GIS"."DOMAIN_WTRNDETYPE" ADD CONSTRAINT "PK_DOMAIN_WTRNDETYPE" PRIMARY
KEY ("TYPE") ENABLE;
ALTER TABLE "GIS"."DOMAIN_WTRNDETYPE" MODIFY ("TYPE" NOT NULL ENABLE);
-----
-- Constraints for Table DOMAIN_EXTERNALINTERESTTYPE
-----
ALTER TABLE "GIS"."DOMAIN_EXTERNALINTERESTTYPE" ADD CONSTRAINT
"PK_DOMAIN_EXTERNALINTERESTTYPE" PRIMARY KEY ("TYPE") ENABLE;
ALTER TABLE "GIS"."DOMAIN_EXTERNALINTERESTTYPE" MODIFY ("TYPE" NOT NULL ENABLE);
-----
-- Constraints for Table DOMAIN_NDESHPTYPE
-----
ALTER TABLE "GIS"."DOMAIN_NDESHPTYPE" ADD CONSTRAINT "PK_DOMAIN_NDESHPTYPE" PRIMARY
KEY ("TYPE") ENABLE;
ALTER TABLE "GIS"."DOMAIN_NDESHPTYPE" MODIFY ("TYPE" NOT NULL ENABLE);
-----
-- Constraints for Table WASTEWATERSEGMENT
-----
ALTER TABLE "GIS"."WASTEWATERSEGMENT" ADD CONSTRAINT "PK_WASTEWATERSEGMENT" PRIMARY
KEY ("XFM_ID") ENABLE;
-----
-- Constraints for Table DOMAIN_NETWORKTYPE
-----
ALTER TABLE "GIS"."DOMAIN_NETWORKTYPE" ADD CONSTRAINT "PK_DOMAIN_NETWORKTYPE"
PRIMARY KEY ("TYPE") ENABLE;
ALTER TABLE "GIS"."DOMAIN_NETWORKTYPE" MODIFY ("TYPE" NOT NULL ENABLE);
-----
-- Constraints for Table DOMAIN_PAVEMENTSECTIONT
-----
ALTER TABLE "GIS"."DOMAIN_PAVEMENTSECTIONT" ADD CONSTRAINT "PK_DOMAIN_PAVEMENTSE"
PRIMARY KEY ("TYPE") ENABLE;
ALTER TABLE "GIS"."DOMAIN_PAVEMENTSECTIONT" MODIFY ("TYPE" NOT NULL ENABLE);
-----
-- Constraints for Table DOMAIN_TOWERUSETYPE
-----
ALTER TABLE "GIS"."DOMAIN_TOWERUSETYPE" ADD CONSTRAINT "PK_DOMAIN_TOWERUSETYPE"
PRIMARY KEY ("TYPE") ENABLE;
ALTER TABLE "GIS"."DOMAIN_TOWERUSETYPE" MODIFY ("TYPE" NOT NULL ENABLE);
-----
-- Constraints for Table PAVEMENTSECTION
-----
ALTER TABLE "GIS"."PAVEMENTSECTION" ADD CONSTRAINT "PK_PAVEMENTSECTION" PRIMARY KEY
("XFM_ID") ENABLE;
-----
-- Constraints for Table DOMAIN STRUCTURALCONDITION
-----

```

```

ALTER TABLE "GIS"."DOMAIN_STRUCTURALCONDITION" ADD CONSTRAINT
"PK_DOMAIN_STRUCTURALCONDITION" PRIMARY KEY ("TYPE") ENABLE;
ALTER TABLE "GIS"."DOMAIN_STRUCTURALCONDITION" MODIFY ("TYPE" NOT NULL ENABLE);
-----
-- Constraints for Table DOMAIN_UTLNDETYPE
-----
ALTER TABLE "GIS"."DOMAIN_UTLNDETYPE" ADD CONSTRAINT "PK_DOMAIN_UTLNDETYPE" PRIMARY
KEY ("TYPE") ENABLE;
ALTER TABLE "GIS"."DOMAIN_UTLNDETYPE" MODIFY ("TYPE" NOT NULL ENABLE);
-----
-- Constraints for Table DOMAIN_ENDETYPE
-----
ALTER TABLE "GIS"."DOMAIN_ENDETYPE" ADD CONSTRAINT "PK_DOMAIN_ENDETYPE" PRIMARY KEY
("TYPE") ENABLE;
ALTER TABLE "GIS"."DOMAIN_ENDETYPE" MODIFY ("TYPE" NOT NULL ENABLE);
-----
-- Constraints for Table DOMAIN_CONFLICTTYPE
-----
ALTER TABLE "GIS"."DOMAIN_CONFLICTTYPE" ADD CONSTRAINT "PK_DOMAIN_CONFLICTTYPE"
PRIMARY KEY ("TYPE") ENABLE;
ALTER TABLE "GIS"."DOMAIN_CONFLICTTYPE" MODIFY ("TYPE" NOT NULL ENABLE);
-----
-- Constraints for Table DOMAIN_UTILITYRESOLUTIONSTATUS
-----
ALTER TABLE "GIS"."DOMAIN_UTILITYRESOLUTIONSTATUS" ADD CONSTRAINT
"PK_DOMAIN_UTILITYRESOLUTIONSTA" PRIMARY KEY ("TYPE") ENABLE;
ALTER TABLE "GIS"."DOMAIN_UTILITYRESOLUTIONSTATUS" MODIFY ("TYPE" NOT NULL ENABLE);
-----
-- Constraints for Table WALL
-----
ALTER TABLE "GIS"."WALL" ADD CONSTRAINT "PK_WALL" PRIMARY KEY ("XFM_ID") ENABLE;
-----
-- Constraints for Table WATERSEGMENT
-----
ALTER TABLE "GIS"."WATERSEGMENT" ADD CONSTRAINT "PK_WATERSEGMENT" PRIMARY KEY
("XFM_ID") ENABLE;
-----
-- Constraints for Table DOMAIN_COMSEGTYPE
-----
ALTER TABLE "GIS"."DOMAIN_COMSEGTYPE" ADD CONSTRAINT "PK_DOMAIN_COMSEGTYPE" PRIMARY
KEY ("TYPE") ENABLE;
ALTER TABLE "GIS"."DOMAIN_COMSEGTYPE" MODIFY ("TYPE" NOT NULL ENABLE);
-----
-- Constraints for Table DOMAIN_POLSEGTYPE
-----
ALTER TABLE "GIS"."DOMAIN_POLSEGTYPE" ADD CONSTRAINT "PK_DOMAIN_POLSEGTYPE" PRIMARY
KEY ("TYPE") ENABLE;
ALTER TABLE "GIS"."DOMAIN_POLSEGTYPE" MODIFY ("TYPE" NOT NULL ENABLE);
-----
-- Constraints for Table DOMAIN_POLNETTYPE
-----
ALTER TABLE "GIS"."DOMAIN_POLNETTYPE" ADD CONSTRAINT "PK_DOMAIN_POLNETTYPE" PRIMARY
KEY ("TYPE") ENABLE;
ALTER TABLE "GIS"."DOMAIN_POLNETTYPE" MODIFY ("TYPE" NOT NULL ENABLE);
-----
-- Constraints for Table GRID

```

```

-----
ALTER TABLE "GIS"."GRID" ADD CONSTRAINT "PK_GRID" PRIMARY KEY ("XFM_ID") ENABLE;
-----
-- Constraints for Table DOMAIN_FENCEUSETYPE
-----
ALTER TABLE "GIS"."DOMAIN_FENCEUSETYPE" ADD CONSTRAINT "PK_DOMAIN_FENCEUSETYPE"
PRIMARY KEY ("TYPE") ENABLE;
ALTER TABLE "GIS"."DOMAIN_FENCEUSETYPE" MODIFY ("TYPE" NOT NULL ENABLE);
-----
-- Constraints for Table DOMAIN_UTILITYRESOLUTIONS
-----
ALTER TABLE "GIS"."DOMAIN_UTILITYRESOLUTIONS" ADD CONSTRAINT
"PK_DOMAIN_UTILITYRESOLUTIONS" PRIMARY KEY ("TYPE") ENABLE;
ALTER TABLE "GIS"."DOMAIN_UTILITYRESOLUTIONS" MODIFY ("TYPE" NOT NULL ENABLE);
-----
-- Constraints for Table DOMAIN_RECREATIONAREATYPE
-----
ALTER TABLE "GIS"."DOMAIN_RECREATIONAREATYPE" ADD CONSTRAINT
"PK_DOMAIN_RECREATIONAREATYPE" PRIMARY KEY ("TYPE") ENABLE;
ALTER TABLE "GIS"."DOMAIN_RECREATIONAREATYPE" MODIFY ("TYPE" NOT NULL ENABLE);
-----
-- Constraints for Table ELECTRICALSEGMENT
-----
ALTER TABLE "GIS"."ELECTRICALSEGMENT" ADD CONSTRAINT "PK_ELECTRICALSEGMENT" PRIMARY
KEY ("XFM_ID") ENABLE;
-----
-- Constraints for Table RECREATIONFEATURE
-----
ALTER TABLE "GIS"."RECREATIONFEATURE" ADD CONSTRAINT "PK_RECREATIONFEATURE" PRIMARY
KEY ("XFM_ID") ENABLE;
-----
-- Constraints for Table DOMAIN_COMNETTYPE
-----
ALTER TABLE "GIS"."DOMAIN_COMNETTYPE" ADD CONSTRAINT "PK_DOMAIN_COMNETTYPE" PRIMARY
KEY ("TYPE") ENABLE;
ALTER TABLE "GIS"."DOMAIN_COMNETTYPE" MODIFY ("TYPE" NOT NULL ENABLE);
-----
-- Constraints for Table COMMUNICATIONNODE
-----
ALTER TABLE "GIS"."COMMUNICATIONNODE" ADD CONSTRAINT "PK_COMMUNICATIONNODE" PRIMARY
KEY ("XFM_ID") ENABLE;
-----
-- Constraints for Table POLNODE
-----
ALTER TABLE "GIS"."POLNODE" ADD CONSTRAINT "PK_POLNODE" PRIMARY KEY ("XFM_ID") ENABLE;
-----
-- Constraints for Table DOMAIN_NETWORKSUBTYPE
-----
ALTER TABLE "GIS"."DOMAIN_NETWORKSUBTYPE" ADD CONSTRAINT "PK_DOMAIN_NETWORKSUBTYPE"
PRIMARY KEY ("TYPE") ENABLE;
ALTER TABLE "GIS"."DOMAIN_NETWORKSUBTYPE" MODIFY ("TYPE" NOT NULL ENABLE);
-----
-- Constraints for Table DOMAIN_POLNDETYPE
-----
ALTER TABLE "GIS"."DOMAIN_POLNDETYPE" ADD CONSTRAINT "PK_DOMAIN_POLNDETYPE" PRIMARY
KEY ("TYPE") ENABLE;

```

```

ALTER TABLE "GIS"."DOMAIN_POLNDETYPE" MODIFY ("TYPE" NOT NULL ENABLE);
-----
-- Constraints for Table DOMAIN_BRIDGETYPE
-----
ALTER TABLE "GIS"."DOMAIN_BRIDGETYPE" ADD CONSTRAINT "PK_DOMAIN_BRIDGETYPE" PRIMARY
KEY ("TYPE") ENABLE;
ALTER TABLE "GIS"."DOMAIN_BRIDGETYPE" MODIFY ("TYPE" NOT NULL ENABLE);
-----
-- Constraints for Table RAILTRACK
-----
ALTER TABLE "GIS"."RAILTRACK" ADD CONSTRAINT "PK_RAILTRACK" PRIMARY KEY ("XFM_ID")
ENABLE;
-----
-- Constraints for Table DOMAIN_GASNDETYPE
-----
ALTER TABLE "GIS"."DOMAIN_GASNDETYPE" ADD CONSTRAINT "PK_DOMAIN_GASNDETYPE" PRIMARY
KEY ("TYPE") ENABLE;
ALTER TABLE "GIS"."DOMAIN_GASNDETYPE" MODIFY ("TYPE" NOT NULL ENABLE);
-----
-- Ref Constraints for Table SIGN
-----
ALTER TABLE "GIS"."SIGN" ADD CONSTRAINT "FK_0_DOMAIN_SIGNTYPE" FOREIGN KEY
("SIGNTYPE")
REFERENCES "GIS"."DOMAIN_SIGNTYPE" ("TYPE") DISABLE;
ALTER TABLE "GIS"."SIGN" ADD CONSTRAINT "FK_21_DOMAIN_UTILITYINVESTATI" FOREIGN KEY
("INVESTIGATIONLEVEL")
REFERENCES "GIS"."DOMAIN_UTILITYINVESTATIONLEVEL" ("TYPE") DISABLE;
ALTER TABLE "GIS"."SIGN" ADD CONSTRAINT "FK_28_DOMAIN_RES" FOREIGN KEY ("RESOLUTION")
REFERENCES "GIS"."DOMAIN_UTILITYRESOLUTIONS" ("TYPE") DISABLE;
ALTER TABLE "GIS"."SIGN" ADD CONSTRAINT "FK_28_DOMAIN_RESSTATUS" FOREIGN KEY
("RESOLUTIONSTATUS")
REFERENCES "GIS"."DOMAIN_UTILITYRESOLUTIONSTATUS" ("TYPE") DISABLE;
ALTER TABLE "GIS"."SIGN" ADD CONSTRAINT "FK_29_DOMAIN_UTILITYDATAQUALI" FOREIGN KEY
("QUALITYLEVEL")
REFERENCES "GIS"."DOMAIN_UTILITYDATAQUALITY" ("TYPE") DISABLE;
ALTER TABLE "GIS"."SIGN" ADD CONSTRAINT "FK_9_DOMAIN_UTILOPSTAT" FOREIGN KEY
("OPERATIONALSTATUS")
REFERENCES "GIS"."DOMAIN_UTILOPSTAT" ("TYPE") DISABLE;
-----
-- Ref Constraints for Table CONSTRUCTIONLINE
-----
ALTER TABLE "GIS"."CONSTRUCTIONLINE" ADD CONSTRAINT "FK_26_DOMAIN_UTILITYINVESTATI"
FOREIGN KEY ("INVESTIGATIONLEVEL")
REFERENCES "GIS"."DOMAIN_UTILITYINVESTATIONLEVEL" ("TYPE") DISABLE;
ALTER TABLE "GIS"."CONSTRUCTIONLINE" ADD CONSTRAINT "FK_34_DOMAIN_UTILOPSTAT"
FOREIGN KEY ("OPERATIONALSTATUS")
REFERENCES "GIS"."DOMAIN_UTILOPSTAT" ("TYPE") DISABLE;
ALTER TABLE "GIS"."CONSTRUCTIONLINE" ADD CONSTRAINT "FK_4_DOMAIN_RES" FOREIGN KEY
("RESOLUTION")
REFERENCES "GIS"."DOMAIN_UTILITYRESOLUTIONS" ("TYPE") DISABLE;
ALTER TABLE "GIS"."CONSTRUCTIONLINE" ADD CONSTRAINT "FK_4_DOMAIN_RESSTATUS" FOREIGN
KEY ("RESOLUTIONSTATUS")
REFERENCES "GIS"."DOMAIN_UTILITYRESOLUTIONSTATUS" ("TYPE") DISABLE;
ALTER TABLE "GIS"."CONSTRUCTIONLINE" ADD CONSTRAINT "FK_4_DOMAIN_UTILITYDATAQUALI"
FOREIGN KEY ("QUALITYLEVEL")
REFERENCES "GIS"."DOMAIN_UTILITYDATAQUALITY" ("TYPE") DISABLE;

```

```
-----
-- Ref Constraints for Table FENCE
-----
```

```
ALTER TABLE "GIS"."FENCE" ADD CONSTRAINT "FK_12_DOMAIN_RES" FOREIGN KEY
("RESOLUTION")
REFERENCES "GIS"."DOMAIN_UTILITYRESOLUTIONS" ("TYPE") DISABLE;
ALTER TABLE "GIS"."FENCE" ADD CONSTRAINT "FK_12_DOMAIN_RESSTATUS" FOREIGN KEY
("RESOLUTIONSTATUS")
REFERENCES "GIS"."DOMAIN_UTILITYRESOLUTIONSTATUS" ("TYPE") DISABLE;
```

```
-----
-- Ref Constraints for Table WATERCOURSELINE
-----
```

```
ALTER TABLE "GIS"."WATERCOURSELINE" ADD CONSTRAINT "FK_0_DOMAIN_WATERCOURSEELEMEN"
FOREIGN KEY ("WATERCOURSEELEMENT")
REFERENCES "GIS"."DOMAIN_WATERCOURSEELEMENTTYPE" ("TYPE") DISABLE;
ALTER TABLE "GIS"."WATERCOURSELINE" ADD CONSTRAINT "FK_10_DOMAIN_UTILITYDATAQUALI"
FOREIGN KEY ("QUALITYLEVEL")
REFERENCES "GIS"."DOMAIN_UTILITYDATAQUALITY" ("TYPE") DISABLE;
ALTER TABLE "GIS"."WATERCOURSELINE" ADD CONSTRAINT "FK_19_DOMAIN_UTILITYINVESTATI"
FOREIGN KEY ("INVESTIGATIONLEVEL")
REFERENCES "GIS"."DOMAIN_UTILITYINVESTATIONLEVEL" ("TYPE") DISABLE;
ALTER TABLE "GIS"."WATERCOURSELINE" ADD CONSTRAINT "FK_37_DOMAIN_UTILLOPSTAT" FOREIGN
KEY ("OPERATIONALSTATUS")
REFERENCES "GIS"."DOMAIN_UTILLOPSTAT" ("TYPE") DISABLE;
ALTER TABLE "GIS"."WATERCOURSELINE" ADD CONSTRAINT "FK_41_DOMAIN_RES" FOREIGN KEY
("RESOLUTION")
REFERENCES "GIS"."DOMAIN_UTILITYRESOLUTIONS" ("TYPE") DISABLE;
ALTER TABLE "GIS"."WATERCOURSELINE" ADD CONSTRAINT "FK_41_DOMAIN_RESSTATUS" FOREIGN
KEY ("RESOLUTIONSTATUS")
REFERENCES "GIS"."DOMAIN_UTILITYRESOLUTIONSTATUS" ("TYPE") DISABLE;
```

```
-----
-- Ref Constraints for Table ROADPATH
-----
```

```
ALTER TABLE "GIS"."ROADPATH" ADD CONSTRAINT "FK_15_DOMAIN_UTILITYDATAQUALI" FOREIGN
KEY ("QUALITYLEVEL")
REFERENCES "GIS"."DOMAIN_UTILITYDATAQUALITY" ("TYPE") DISABLE;
ALTER TABLE "GIS"."ROADPATH" ADD CONSTRAINT "FK_27_DOMAIN_RES" FOREIGN KEY
("RESOLUTION")
REFERENCES "GIS"."DOMAIN_UTILITYRESOLUTIONS" ("TYPE") DISABLE;
ALTER TABLE "GIS"."ROADPATH" ADD CONSTRAINT "FK_27_DOMAIN_RESSTATUS" FOREIGN KEY
("RESOLUTIONSTATUS")
REFERENCES "GIS"."DOMAIN_UTILITYRESOLUTIONSTATUS" ("TYPE") DISABLE;
ALTER TABLE "GIS"."ROADPATH" ADD CONSTRAINT "FK_28_DOMAIN_UTILLOPSTAT" FOREIGN KEY
("OPERATIONALSTATUS")
REFERENCES "GIS"."DOMAIN_UTILLOPSTAT" ("TYPE") DISABLE;
ALTER TABLE "GIS"."ROADPATH" ADD CONSTRAINT "FK_5_DOMAIN_UTILITYINVESTATI" FOREIGN
KEY ("INVESTIGATIONLEVEL")
REFERENCES "GIS"."DOMAIN_UTILITYINVESTATIONLEVEL" ("TYPE") DISABLE;
```

```
-----
-- Ref Constraints for Table BRIDGE
-----
```

```
ALTER TABLE "GIS"."BRIDGE" ADD CONSTRAINT "FK_0_DOMAIN_BRIDGETYPE" FOREIGN KEY
("BRIDGETYPE")
REFERENCES "GIS"."DOMAIN_BRIDGETYPE" ("TYPE") DISABLE;
ALTER TABLE "GIS"."BRIDGE" ADD CONSTRAINT "FK_0_DOMAIN_RES" FOREIGN KEY
("RESOLUTION")
```

```

REFERENCES "GIS"."DOMAIN_UTILITYRESOLUTIONS" ("TYPE") DISABLE;
ALTER TABLE "GIS"."BRIDGE" ADD CONSTRAINT "FK_0_DOMAIN_RESSTATUS" FOREIGN KEY
("RESOLUTIONSTATUS")
REFERENCES "GIS"."DOMAIN_UTILITYRESOLUTIONSTATUS" ("TYPE") DISABLE;
ALTER TABLE "GIS"."BRIDGE" ADD CONSTRAINT "FK_0_DOMAIN_UTILITYINVESTATI" FOREIGN KEY
("INVESTIGATIONLEVEL")
REFERENCES "GIS"."DOMAIN_UTILITYINVESTATIONLEVEL" ("TYPE") DISABLE;
ALTER TABLE "GIS"."BRIDGE" ADD CONSTRAINT "FK_1_DOMAIN_GSIP_LENGTHUOM" FOREIGN KEY
("REFERENCEELEVUOM")
REFERENCES "GIS"."DOMAIN_GSIP_LENGTHUOM" ("TYPE") DISABLE;
ALTER TABLE "GIS"."BRIDGE" ADD CONSTRAINT "FK_1_DOMAIN_UTILITYDATAQUALI" FOREIGN KEY
("QUALITYLEVEL")
REFERENCES "GIS"."DOMAIN_UTILITYDATAQUALITY" ("TYPE") DISABLE;
ALTER TABLE "GIS"."BRIDGE" ADD CONSTRAINT "FK_1_DOMAIN_VERTICALDATUMTYP" FOREIGN KEY
("REFERENCEELEVVERTDATUM")
REFERENCES "GIS"."DOMAIN_VERTICALDATUMTYPE" ("TYPE") DISABLE;
ALTER TABLE "GIS"."BRIDGE" ADD CONSTRAINT "FK_2_DOMAIN_GSIP_LENGTHUOM" FOREIGN KEY
("HORIZONTALCLEARANCEUOM")
REFERENCES "GIS"."DOMAIN_GSIP_LENGTHUOM" ("TYPE") DISABLE;
ALTER TABLE "GIS"."BRIDGE" ADD CONSTRAINT "FK_38_DOMAIN_UTILOPSTAT" FOREIGN KEY
("OPERATIONALSTATUS")
REFERENCES "GIS"."DOMAIN_UTILOPSTAT" ("TYPE") DISABLE;
ALTER TABLE "GIS"."BRIDGE" ADD CONSTRAINT "FK_3_DOMAIN_GSIP_LENGTHUOM" FOREIGN KEY
("VERTCLEARANCEOPENUOM")
REFERENCES "GIS"."DOMAIN_GSIP_LENGTHUOM" ("TYPE") DISABLE;
ALTER TABLE "GIS"."BRIDGE" ADD CONSTRAINT "FK_4_DOMAIN_GSIP_LENGTHUOM" FOREIGN KEY
("LOWCHORDELEVATIONUOM")
REFERENCES "GIS"."DOMAIN_GSIP_LENGTHUOM" ("TYPE") DISABLE;
ALTER TABLE "GIS"."BRIDGE" ADD CONSTRAINT "FK_7_DOMAIN_GSIP_LENGTHUOM" FOREIGN KEY
("VERTCLEARANCECLOSEDUOM")
REFERENCES "GIS"."DOMAIN_GSIP_LENGTHUOM" ("TYPE") DISABLE;

```

```
-- Ref Constraints for Table TOWER
```

```

ALTER TABLE "GIS"."TOWER" ADD CONSTRAINT "FK_0_DOMAIN_STRUCTURALCONDIT" FOREIGN KEY
("TOWERCONDITION")
REFERENCES "GIS"."DOMAIN_STRUCTURALCONDITION" ("TYPE") DISABLE;
ALTER TABLE "GIS"."TOWER" ADD CONSTRAINT "FK_0_DOMAIN_TOWERUSETYPE" FOREIGN KEY
("TOWERUSETYPE")
REFERENCES "GIS"."DOMAIN_TOWERUSETYPE" ("TYPE") DISABLE;
ALTER TABLE "GIS"."TOWER" ADD CONSTRAINT "FK_0_DOMAIN_UTILITYDATAQUALI" FOREIGN KEY
("QUALITYLEVEL")
REFERENCES "GIS"."DOMAIN_UTILITYDATAQUALITY" ("TYPE") DISABLE;
ALTER TABLE "GIS"."TOWER" ADD CONSTRAINT "FK_12_DOMAIN_UTILOPSTAT" FOREIGN KEY
("OPERATIONALSTATUS")
REFERENCES "GIS"."DOMAIN_UTILOPSTAT" ("TYPE") DISABLE;
ALTER TABLE "GIS"."TOWER" ADD CONSTRAINT "FK_1_DOMAIN_STRUCTUREMATERIA" FOREIGN KEY
("TOWERMATERIAL")
REFERENCES "GIS"."DOMAIN_STRUCTUREMATERIAL" ("TYPE") DISABLE;
ALTER TABLE "GIS"."TOWER" ADD CONSTRAINT "FK_22_DOMAIN_UTILITYINVESTATI" FOREIGN KEY
("INVESTIGATIONLEVEL")
REFERENCES "GIS"."DOMAIN_UTILITYINVESTATIONLEVEL" ("TYPE") DISABLE;
ALTER TABLE "GIS"."TOWER" ADD CONSTRAINT "FK_35_DOMAIN_RES" FOREIGN KEY
("RESOLUTION")
REFERENCES "GIS"."DOMAIN_UTILITYRESOLUTIONS" ("TYPE") DISABLE;

```



```

ALTER TABLE "GIS"."TOWER" ADD CONSTRAINT "FK_35_DOMAIN_RESSTATUS" FOREIGN KEY
("RESOLUTIONSTATUS")
  REFERENCES "GIS"."DOMAIN_UTILITYRESOLUTIONSTATUS" ("TYPE") DISABLE;
ALTER TABLE "GIS"."TOWER" ADD CONSTRAINT "FK_8_DOMAIN_GSIP_LENGTHUOM" FOREIGN KEY
("HEIGHTUOM")
  REFERENCES "GIS"."DOMAIN_GSIP_LENGTHUOM" ("TYPE") DISABLE;
-----
-- Ref Constraints for Table THERMALSEGMENT
-----
ALTER TABLE "GIS"."THERMALSEGMENT" ADD CONSTRAINT "FK_0_DOMAIN_THMNETTYPE" FOREIGN
KEY ("THERMNETWORKTYPE")
  REFERENCES "GIS"."DOMAIN_THMNETTYPE" ("TYPE") DISABLE;
ALTER TABLE "GIS"."THERMALSEGMENT" ADD CONSTRAINT "FK_0_DOMAIN_THMSEGTYPE" FOREIGN
KEY ("THERMSEGMENTTYPE")
  REFERENCES "GIS"."DOMAIN_THMSEGTYPE" ("TYPE") DISABLE;
ALTER TABLE "GIS"."THERMALSEGMENT" ADD CONSTRAINT "FK_27_DOMAIN_UTILOPSTAT" FOREIGN
KEY ("OPERATIONALSTATUS")
  REFERENCES "GIS"."DOMAIN_UTILOPSTAT" ("TYPE") DISABLE;
ALTER TABLE "GIS"."THERMALSEGMENT" ADD CONSTRAINT "FK_2_DOMAIN_SEGTYPE" FOREIGN KEY
("SEGMENTTYPE")
  REFERENCES "GIS"."DOMAIN_SEGTYPE" ("TYPE") DISABLE;
ALTER TABLE "GIS"."THERMALSEGMENT" ADD CONSTRAINT "FK_34_DOMAIN_RES" FOREIGN KEY
("RESOLUTION")
  REFERENCES "GIS"."DOMAIN_UTILITYRESOLUTIONS" ("TYPE") DISABLE;
ALTER TABLE "GIS"."THERMALSEGMENT" ADD CONSTRAINT "FK_34_DOMAIN_RESSTATUS" FOREIGN
KEY ("RESOLUTIONSTATUS")
  REFERENCES "GIS"."DOMAIN_UTILITYRESOLUTIONSTATUS" ("TYPE") DISABLE;
ALTER TABLE "GIS"."THERMALSEGMENT" ADD CONSTRAINT "FK_37_DOMAIN_UTILITYDATAQUALI"
FOREIGN KEY ("QUALITYLEVEL")
  REFERENCES "GIS"."DOMAIN_UTILITYDATAQUALITY" ("TYPE") DISABLE;
ALTER TABLE "GIS"."THERMALSEGMENT" ADD CONSTRAINT "FK_39_DOMAIN_UTILITYINVESTATI"
FOREIGN KEY ("INVESTIGATIONLEVEL")
  REFERENCES "GIS"."DOMAIN_UTILITYINVESTATIONLEVEL" ("TYPE") DISABLE;
ALTER TABLE "GIS"."THERMALSEGMENT" ADD CONSTRAINT "FK_3_DOMAIN_PIPEMATERIAL" FOREIGN
KEY ("MATERIAL")
  REFERENCES "GIS"."DOMAIN_PIPEMATERIAL" ("TYPE") DISABLE;
ALTER TABLE "GIS"."THERMALSEGMENT" ADD CONSTRAINT "FK_5_DOMAIN_SEGSHPTYPE" FOREIGN
KEY ("SEGMENTSHAPETYPE")
  REFERENCES "GIS"."DOMAIN_SEGSHPTYPE" ("TYPE") DISABLE;
-----
-- Ref Constraints for Table COMMUNICATIONSEGMENT
-----
ALTER TABLE "GIS"."COMMUNICATIONSEGMENT" ADD CONSTRAINT "FK_0_DOMAIN_COMSEGTYPE"
FOREIGN KEY ("COMMSEGMENTTYPE")
  REFERENCES "GIS"."DOMAIN_COMSEGTYPE" ("TYPE") DISABLE;
ALTER TABLE "GIS"."COMMUNICATIONSEGMENT" ADD CONSTRAINT
"FK_11_DOMAIN_UTILITYDATAQUALI" FOREIGN KEY ("QUALITYLEVEL")
  REFERENCES "GIS"."DOMAIN_UTILITYDATAQUALITY" ("TYPE") DISABLE;
ALTER TABLE "GIS"."COMMUNICATIONSEGMENT" ADD CONSTRAINT "FK_1_DOMAIN_COMNETTYPE"
FOREIGN KEY ("COMMNETWORKTYPE")
  REFERENCES "GIS"."DOMAIN_COMNETTYPE" ("TYPE") DISABLE;
ALTER TABLE "GIS"."COMMUNICATIONSEGMENT" ADD CONSTRAINT "FK_1_DOMAIN_SEGSHPTYPE"
FOREIGN KEY ("SEGMENTSHAPETYPE")
  REFERENCES "GIS"."DOMAIN_SEGSHPTYPE" ("TYPE") DISABLE;
ALTER TABLE "GIS"."COMMUNICATIONSEGMENT" ADD CONSTRAINT "FK_1_DOMAIN_SEGTYPE"
FOREIGN KEY ("SEGMENTTYPE")

```

```

REFERENCES "GIS"."DOMAIN_SEGTYPE" ("TYPE") DISABLE;
ALTER TABLE "GIS"."COMMUNICATIONSEGMENT" ADD CONSTRAINT "FK_22_DOMAIN_UTILOPSTAT"
FOREIGN KEY ("OPERATIONALSTATUS")
REFERENCES "GIS"."DOMAIN_UTILOPSTAT" ("TYPE") DISABLE;
ALTER TABLE "GIS"."COMMUNICATIONSEGMENT" ADD CONSTRAINT
"FK_38_DOMAIN_UTILITYINVESTATI" FOREIGN KEY ("INVESTIGATIONLEVEL")
REFERENCES "GIS"."DOMAIN_UTILITYINVESTATIONLEVEL" ("TYPE") DISABLE;
ALTER TABLE "GIS"."COMMUNICATIONSEGMENT" ADD CONSTRAINT "FK_3_DOMAIN_RES" FOREIGN KEY
("RESOLUTION")
REFERENCES "GIS"."DOMAIN_UTILITYRESOLUTIONS" ("TYPE") DISABLE;
ALTER TABLE "GIS"."COMMUNICATIONSEGMENT" ADD CONSTRAINT "FK_3_DOMAIN_RESSTATUS"
FOREIGN KEY ("RESOLUTIONSTATUS")
REFERENCES "GIS"."DOMAIN_UTILITYRESOLUTIONSTATUS" ("TYPE") DISABLE;
ALTER TABLE "GIS"."COMMUNICATIONSEGMENT" ADD CONSTRAINT "FK_6_DOMAIN_PIPEMATERIAL"
FOREIGN KEY ("MATERIAL")
REFERENCES "GIS"."DOMAIN_PIPEMATERIAL" ("TYPE") DISABLE;

```

```
-- Ref Constraints for Table STRUCTURE
```

```

ALTER TABLE "GIS"."STRUCTURE" ADD CONSTRAINT "FK_30_DOMAIN_RES" FOREIGN KEY
("RESOLUTION")
REFERENCES "GIS"."DOMAIN_UTILITYRESOLUTIONS" ("TYPE") DISABLE;
ALTER TABLE "GIS"."STRUCTURE" ADD CONSTRAINT "FK_30_DOMAIN_RESSTATUS" FOREIGN KEY
("RESOLUTIONSTATUS")
REFERENCES "GIS"."DOMAIN_UTILITYRESOLUTIONSTATUS" ("TYPE") DISABLE;
ALTER TABLE "GIS"."STRUCTURE" ADD CONSTRAINT "FK_42_DOMAIN_UTILITYDATAQUALI" FOREIGN
KEY ("QUALITYLEVEL")
REFERENCES "GIS"."DOMAIN_UTILITYDATAQUALITY" ("TYPE") DISABLE;
ALTER TABLE "GIS"."STRUCTURE" ADD CONSTRAINT "FK_42_DOMAIN_UTILITYINVESTATI" FOREIGN
KEY ("INVESTIGATIONLEVEL")
REFERENCES "GIS"."DOMAIN_UTILITYINVESTATIONLEVEL" ("TYPE") DISABLE;
ALTER TABLE "GIS"."STRUCTURE" ADD CONSTRAINT "FK_42_DOMAIN_UTILOPSTAT" FOREIGN KEY
("OPERATIONALSTATUS")
REFERENCES "GIS"."DOMAIN_UTILOPSTAT" ("TYPE") DISABLE;

```

```
-- Ref Constraints for Table LANDPARCEL
```

```

ALTER TABLE "GIS"."LANDPARCEL" ADD CONSTRAINT "FK_12_DOMAIN_UTILITYINVESTATI"
FOREIGN KEY ("INVESTIGATIONLEVEL")
REFERENCES "GIS"."DOMAIN_UTILITYINVESTATIONLEVEL" ("TYPE") DISABLE;
ALTER TABLE "GIS"."LANDPARCEL" ADD CONSTRAINT "FK_18_DOMAIN_RES" FOREIGN KEY
("RESOLUTION")
REFERENCES "GIS"."DOMAIN_UTILITYRESOLUTIONS" ("TYPE") DISABLE;
ALTER TABLE "GIS"."LANDPARCEL" ADD CONSTRAINT "FK_18_DOMAIN_RESSTATUS" FOREIGN KEY
("RESOLUTIONSTATUS")
REFERENCES "GIS"."DOMAIN_UTILITYRESOLUTIONSTATUS" ("TYPE") DISABLE;
ALTER TABLE "GIS"."LANDPARCEL" ADD CONSTRAINT "FK_31_DOMAIN_UTILOPSTAT" FOREIGN KEY
("OPERATIONALSTATUS")
REFERENCES "GIS"."DOMAIN_UTILOPSTAT" ("TYPE") DISABLE;
ALTER TABLE "GIS"."LANDPARCEL" ADD CONSTRAINT "FK_38_DOMAIN_UTILITYDATAQUALI"
FOREIGN KEY ("QUALITYLEVEL")
REFERENCES "GIS"."DOMAIN_UTILITYDATAQUALITY" ("TYPE") DISABLE;

```

```
-- Ref Constraints for Table BUILDING
```

```

ALTER TABLE "GIS"."BUILDING" ADD CONSTRAINT "FK_1_DOMAIN_RES" FOREIGN KEY
("RESOLUTION")
REFERENCES "GIS"."DOMAIN_UTILITYRESOLUTIONS" ("TYPE") DISABLE;
ALTER TABLE "GIS"."BUILDING" ADD CONSTRAINT "FK_1_DOMAIN_RESSTATUS" FOREIGN KEY
("RESOLUTIONSTATUS")
REFERENCES "GIS"."DOMAIN_UTILITYRESOLUTIONSTATUS" ("TYPE") DISABLE;
ALTER TABLE "GIS"."BUILDING" ADD CONSTRAINT "FK_40_DOMAIN_UTILITYDATAQUALI" FOREIGN
KEY ("QUALITYLEVEL")
REFERENCES "GIS"."DOMAIN_UTILITYDATAQUALITY" ("TYPE") DISABLE;
ALTER TABLE "GIS"."BUILDING" ADD CONSTRAINT "FK_40_DOMAIN_UTILITYINVESTATI" FOREIGN
KEY ("INVESTIGATIONLEVEL")
REFERENCES "GIS"."DOMAIN_UTILITYINVESTATIONLEVEL" ("TYPE") DISABLE;
ALTER TABLE "GIS"."BUILDING" ADD CONSTRAINT "FK_40_DOMAIN_UTILLOPSTAT" FOREIGN KEY
("OPERATIONALSTATUS")
REFERENCES "GIS"."DOMAIN_UTILLOPSTAT" ("TYPE") DISABLE;
-----
-- Ref Constraints for Table ELECTRICALNODE
-----
ALTER TABLE "GIS"."ELECTRICALNODE" ADD CONSTRAINT "FK_0_DOMAIN_ENDETYPE" FOREIGN KEY
("ELECNODETYPE")
REFERENCES "GIS"."DOMAIN_ENDETYPE" ("TYPE") DISABLE;
ALTER TABLE "GIS"."ELECTRICALNODE" ADD CONSTRAINT "FK_0_DOMAIN_VOLVTYPE" FOREIGN KEY
("VOLUMETYPE")
REFERENCES "GIS"."DOMAIN_VOLVTYPE" ("TYPE") DISABLE;
ALTER TABLE "GIS"."ELECTRICALNODE" ADD CONSTRAINT "FK_11_DOMAIN_UTILITYINVESTATI"
FOREIGN KEY ("INVESTIGATIONLEVEL")
REFERENCES "GIS"."DOMAIN_UTILITYINVESTATIONLEVEL" ("TYPE") DISABLE;
ALTER TABLE "GIS"."ELECTRICALNODE" ADD CONSTRAINT "FK_23_DOMAIN_UTILLOPSTAT" FOREIGN
KEY ("OPERATIONALSTATUS")
REFERENCES "GIS"."DOMAIN_UTILLOPSTAT" ("TYPE") DISABLE;
ALTER TABLE "GIS"."ELECTRICALNODE" ADD CONSTRAINT "FK_27_DOMAIN_UTILITYDATAQUALI"
FOREIGN KEY ("QUALITYLEVEL")
REFERENCES "GIS"."DOMAIN_UTILITYDATAQUALITY" ("TYPE") DISABLE;
ALTER TABLE "GIS"."ELECTRICALNODE" ADD CONSTRAINT "FK_2_DOMAIN_ENETTYPE" FOREIGN KEY
("ELECNETWORKTYPE")
REFERENCES "GIS"."DOMAIN_ENETTYPE" ("TYPE") DISABLE;
ALTER TABLE "GIS"."ELECTRICALNODE" ADD CONSTRAINT "FK_2_DOMAIN_NDESHPTYPE" FOREIGN
KEY ("NODESHAPETYPE")
REFERENCES "GIS"."DOMAIN_NDESHPTYPE" ("TYPE") DISABLE;
ALTER TABLE "GIS"."ELECTRICALNODE" ADD CONSTRAINT "FK_3_DOMAIN_FITVTYPE" FOREIGN KEY
("FITTINGTYPE")
REFERENCES "GIS"."DOMAIN_FITVTYPE" ("TYPE") DISABLE;
ALTER TABLE "GIS"."ELECTRICALNODE" ADD CONSTRAINT "FK_4_DOMAIN_UTLNDETYPE" FOREIGN
KEY ("UTILITYNODETYPE")
REFERENCES "GIS"."DOMAIN_UTLNDETYPE" ("TYPE") DISABLE;
ALTER TABLE "GIS"."ELECTRICALNODE" ADD CONSTRAINT "FK_8_DOMAIN_RES" FOREIGN KEY
("RESOLUTION")
REFERENCES "GIS"."DOMAIN_UTILITYRESOLUTIONS" ("TYPE") DISABLE;
ALTER TABLE "GIS"."ELECTRICALNODE" ADD CONSTRAINT "FK_8_DOMAIN_RESSTATUS" FOREIGN KEY
("RESOLUTIONSTATUS")
REFERENCES "GIS"."DOMAIN_UTILITYRESOLUTIONSTATUS" ("TYPE") DISABLE;
-----
-- Ref Constraints for Table GUARDRAIL
-----
ALTER TABLE "GIS"."GUARDRAIL" ADD CONSTRAINT "FK_0_DOMAIN_STRUCTUREMATERIA" FOREIGN
KEY ("GUARDMATERIAL")

```

```

REFERENCES "GIS"."DOMAIN_STRUCTUREMATERIAL" ("TYPE") DISABLE;
ALTER TABLE "GIS"."GUARDRAIL" ADD CONSTRAINT "FK_16_DOMAIN_RES" FOREIGN KEY
("RESOLUTION")
REFERENCES "GIS"."DOMAIN_UTILITYRESOLUTIONS" ("TYPE") DISABLE;
ALTER TABLE "GIS"."GUARDRAIL" ADD CONSTRAINT "FK_16_DOMAIN_RESSTATUS" FOREIGN KEY
("RESOLUTIONSTATUS")
REFERENCES "GIS"."DOMAIN_UTILITYRESOLUTIONSTATUS" ("TYPE") DISABLE;
ALTER TABLE "GIS"."GUARDRAIL" ADD CONSTRAINT "FK_18_DOMAIN_UTILITYDATAQUALI" FOREIGN
KEY ("QUALITYLEVEL")
REFERENCES "GIS"."DOMAIN_UTILITYDATAQUALITY" ("TYPE") DISABLE;
ALTER TABLE "GIS"."GUARDRAIL" ADD CONSTRAINT "FK_1_DOMAIN_UTILOPSTAT" FOREIGN KEY
("OPERATIONALSTATUS")
REFERENCES "GIS"."DOMAIN_UTILOPSTAT" ("TYPE") DISABLE;
ALTER TABLE "GIS"."GUARDRAIL" ADD CONSTRAINT "FK_3_DOMAIN_UTILITYINVESTATI" FOREIGN
KEY ("INVESTIGATIONLEVEL")
REFERENCES "GIS"."DOMAIN_UTILITYINVESTATIONLEVEL" ("TYPE") DISABLE;
ALTER TABLE "GIS"."GUARDRAIL" ADD CONSTRAINT "FK_6_DOMAIN_GSIP_LENGTHUOM" FOREIGN KEY
("HEIGHTUOM")
REFERENCES "GIS"."DOMAIN_GSIP_LENGTHUOM" ("TYPE") DISABLE;
-----
-- Ref Constraints for Table GASNODE
-----
ALTER TABLE "GIS"."GASNODE" ADD CONSTRAINT "FK_0_DOMAIN_FITTYPE" FOREIGN KEY
("FITTINGTYPE")
REFERENCES "GIS"."DOMAIN_FITTYPE" ("TYPE") DISABLE;
ALTER TABLE "GIS"."GASNODE" ADD CONSTRAINT "FK_0_DOMAIN_GASNDETYPE" FOREIGN KEY
("GASNODETYPE")
REFERENCES "GIS"."DOMAIN_GASNDETYPE" ("TYPE") DISABLE;
ALTER TABLE "GIS"."GASNODE" ADD CONSTRAINT "FK_13_DOMAIN_RES" FOREIGN KEY
("RESOLUTION")
REFERENCES "GIS"."DOMAIN_UTILITYRESOLUTIONS" ("TYPE") DISABLE;
ALTER TABLE "GIS"."GASNODE" ADD CONSTRAINT "FK_13_DOMAIN_RESSTATUS" FOREIGN KEY
("RESOLUTIONSTATUS")
REFERENCES "GIS"."DOMAIN_UTILITYRESOLUTIONSTATUS" ("TYPE") DISABLE;
ALTER TABLE "GIS"."GASNODE" ADD CONSTRAINT "FK_1_DOMAIN_GASNETTYPE" FOREIGN KEY
("GASNETWORKTYPE")
REFERENCES "GIS"."DOMAIN_GASNETTYPE" ("TYPE") DISABLE;
ALTER TABLE "GIS"."GASNODE" ADD CONSTRAINT "FK_29_DOMAIN_UTILOPSTAT" FOREIGN KEY
("OPERATIONALSTATUS")
REFERENCES "GIS"."DOMAIN_UTILOPSTAT" ("TYPE") DISABLE;
ALTER TABLE "GIS"."GASNODE" ADD CONSTRAINT "FK_2_DOMAIN_UTLNDETYPE" FOREIGN KEY
("UTILITYNODETYPE")
REFERENCES "GIS"."DOMAIN_UTLNDETYPE" ("TYPE") DISABLE;
ALTER TABLE "GIS"."GASNODE" ADD CONSTRAINT "FK_33_DOMAIN_UTILITYDATAQUALI" FOREIGN
KEY ("QUALITYLEVEL")
REFERENCES "GIS"."DOMAIN_UTILITYDATAQUALITY" ("TYPE") DISABLE;
ALTER TABLE "GIS"."GASNODE" ADD CONSTRAINT "FK_3_DOMAIN_NDESHPTYPE" FOREIGN KEY
("NODESHAPETYPE")
REFERENCES "GIS"."DOMAIN_NDESHPTYPE" ("TYPE") DISABLE;
ALTER TABLE "GIS"."GASNODE" ADD CONSTRAINT "FK_3_DOMAIN_VOLTYPE" FOREIGN KEY
("VOLUMETYPE")
REFERENCES "GIS"."DOMAIN_VOLTYPE" ("TYPE") DISABLE;
ALTER TABLE "GIS"."GASNODE" ADD CONSTRAINT "FK_8_DOMAIN_UTILITYINVESTATI" FOREIGN KEY
("INVESTIGATIONLEVEL")
REFERENCES "GIS"."DOMAIN_UTILITYINVESTATIONLEVEL" ("TYPE") DISABLE;
-----

```

```
-- Ref Constraints for Table GASSEGMENT
```

```
-----
ALTER TABLE "GIS"."GASSEGMENT" ADD CONSTRAINT "FK_0_DOMAIN_GASNETTYPE" FOREIGN KEY
("GASNETWORKTYPE")
REFERENCES "GIS"."DOMAIN_GASNETTYPE" ("TYPE") DISABLE;
ALTER TABLE "GIS"."GASSEGMENT" ADD CONSTRAINT "FK_0_DOMAIN_GASSEGETYPE" FOREIGN KEY
("GASSEGETYPE")
REFERENCES "GIS"."DOMAIN_GASSEGETYPE" ("TYPE") DISABLE;
ALTER TABLE "GIS"."GASSEGMENT" ADD CONSTRAINT "FK_0_DOMAIN_UTILOPSTAT" FOREIGN KEY
("OPERATIONALSTATUS")
REFERENCES "GIS"."DOMAIN_UTILOPSTAT" ("TYPE") DISABLE;
ALTER TABLE "GIS"."GASSEGMENT" ADD CONSTRAINT "FK_14_DOMAIN_RES" FOREIGN KEY
("RESOLUTION")
REFERENCES "GIS"."DOMAIN_UTILITYRESOLUTIONS" ("TYPE") DISABLE;
ALTER TABLE "GIS"."GASSEGMENT" ADD CONSTRAINT "FK_14_DOMAIN_RESSTATUS" FOREIGN KEY
("RESOLUTIONSTATUS")
REFERENCES "GIS"."DOMAIN_UTILITYRESOLUTIONSTATUS" ("TYPE") DISABLE;
ALTER TABLE "GIS"."GASSEGMENT" ADD CONSTRAINT "FK_20_DOMAIN_UTILITYINVESTATI"
FOREIGN KEY ("INVESTIGATIONLEVEL")
REFERENCES "GIS"."DOMAIN_UTILITYINVESTATIONLEVEL" ("TYPE") DISABLE;
ALTER TABLE "GIS"."GASSEGMENT" ADD CONSTRAINT "FK_28_DOMAIN_UTILITYDATAQUALI"
FOREIGN KEY ("QUALITYLEVEL")
REFERENCES "GIS"."DOMAIN_UTILITYDATAQUALITY" ("TYPE") DISABLE;
ALTER TABLE "GIS"."GASSEGMENT" ADD CONSTRAINT "FK_3_DOMAIN_SEGTYPE" FOREIGN KEY
("SEGMENTTYPE")
REFERENCES "GIS"."DOMAIN_SEGTYPE" ("TYPE") DISABLE;
ALTER TABLE "GIS"."GASSEGMENT" ADD CONSTRAINT "FK_4_DOMAIN_PIPEMATERIAL" FOREIGN KEY
("MATERIAL")
REFERENCES "GIS"."DOMAIN_PIPEMATERIAL" ("TYPE") DISABLE;
ALTER TABLE "GIS"."GASSEGMENT" ADD CONSTRAINT "FK_4_DOMAIN_SEGSHPTYPE" FOREIGN KEY
("SEGMENTSHAPETYPE")
REFERENCES "GIS"."DOMAIN_SEGSHPTYPE" ("TYPE") DISABLE;
```

```
-- Ref Constraints for Table SURVEYPOINT
```

```
-----
ALTER TABLE "GIS"."SURVEYPOINT" ADD CONSTRAINT "FK_0_DOMAIN_SURVEYSOURCETYPE"
FOREIGN KEY ("SOURCETYPE")
REFERENCES "GIS"."DOMAIN_SURVEYSOURCETYPE" ("TYPE") DISABLE;
ALTER TABLE "GIS"."SURVEYPOINT" ADD CONSTRAINT "FK_13_DOMAIN_UTILITYINVESTATI"
FOREIGN KEY ("INVESTIGATIONLEVEL")
REFERENCES "GIS"."DOMAIN_UTILITYINVESTATIONLEVEL" ("TYPE") DISABLE;
ALTER TABLE "GIS"."SURVEYPOINT" ADD CONSTRAINT "FK_32_DOMAIN_RES" FOREIGN KEY
("RESOLUTION")
REFERENCES "GIS"."DOMAIN_UTILITYRESOLUTIONS" ("TYPE") DISABLE;
ALTER TABLE "GIS"."SURVEYPOINT" ADD CONSTRAINT "FK_32_DOMAIN_RESSTATUS" FOREIGN KEY
("RESOLUTIONSTATUS")
REFERENCES "GIS"."DOMAIN_UTILITYRESOLUTIONSTATUS" ("TYPE") DISABLE;
ALTER TABLE "GIS"."SURVEYPOINT" ADD CONSTRAINT "FK_32_DOMAIN_UTILOPSTAT" FOREIGN KEY
("OPERATIONALSTATUS")
REFERENCES "GIS"."DOMAIN_UTILOPSTAT" ("TYPE") DISABLE;
ALTER TABLE "GIS"."SURVEYPOINT" ADD CONSTRAINT "FK_3_DOMAIN_UTILITYDATAQUALI"
FOREIGN KEY ("QUALITYLEVEL")
REFERENCES "GIS"."DOMAIN_UTILITYDATAQUALITY" ("TYPE") DISABLE;
```

```
-- Ref Constraints for Table UTILITYFEATURE
```

```

ALTER TABLE "GIS"."UTILITYFEATURE" ADD CONSTRAINT "FK_37_DOMAIN_RES" FOREIGN KEY
("RESOLUTION")
REFERENCES "GIS"."DOMAIN_UTILITYRESOLUTIONS" ("TYPE") DISABLE;
ALTER TABLE "GIS"."UTILITYFEATURE" ADD CONSTRAINT "FK_37_DOMAIN_RESSTATUS" FOREIGN
KEY ("RESOLUTIONSTATUS")
REFERENCES "GIS"."DOMAIN_UTILITYRESOLUTIONSTATUS" ("TYPE") DISABLE;
ALTER TABLE "GIS"."UTILITYFEATURE" ADD CONSTRAINT "FK_43_DOMAIN_NETWORKSUBTYPE"
FOREIGN KEY ("NETWORKSUBTYPE")
REFERENCES "GIS"."DOMAIN_NETWORKSUBTYPE" ("TYPE") DISABLE;
ALTER TABLE "GIS"."UTILITYFEATURE" ADD CONSTRAINT "FK_43_DOMAIN_NETWORKTYPE" FOREIGN
KEY ("NETWORKTYPE")
REFERENCES "GIS"."DOMAIN_NETWORKTYPE" ("TYPE") DISABLE;
ALTER TABLE "GIS"."UTILITYFEATURE" ADD CONSTRAINT "FK_43_DOMAIN_UTILITYDATAQUALI"
FOREIGN KEY ("QUALITYLEVEL")
REFERENCES "GIS"."DOMAIN_UTILITYDATAQUALITY" ("TYPE") DISABLE;
ALTER TABLE "GIS"."UTILITYFEATURE" ADD CONSTRAINT "FK_43_DOMAIN_UTILITYINVESTATI"
FOREIGN KEY ("INVESTIGATIONLEVEL")
REFERENCES "GIS"."DOMAIN_UTILITYINVESTATIONLEVEL" ("TYPE") DISABLE;
ALTER TABLE "GIS"."UTILITYFEATURE" ADD CONSTRAINT "FK_43_DOMAIN_UTILOPSTAT" FOREIGN
KEY ("OPERATIONALSTATUS")
REFERENCES "GIS"."DOMAIN_UTILOPSTAT" ("TYPE") DISABLE;
ALTER TABLE "GIS"."UTILITYFEATURE" ADD CONSTRAINT "FK_43_UTILITYFEATURET" FOREIGN KEY
("UTILITYFEATURETTYPE")
REFERENCES "GIS"."DOMAIN_UTILITYFEATURET" ("TYPE") DISABLE;
-----
-- Ref Constraints for Table WATERFEATURE
-----
ALTER TABLE "GIS"."WATERFEATURE" ADD CONSTRAINT "FK_0_DOMAIN_WTRNDETYPE" FOREIGN KEY
("WATERNODETYPE")
REFERENCES "GIS"."DOMAIN_WTRNDETYPE" ("TYPE") DISABLE;
ALTER TABLE "GIS"."WATERFEATURE" ADD CONSTRAINT "FK_0_DOMAIN_WTRNETTYPE" FOREIGN KEY
("WATERNETWORKTYPE")
REFERENCES "GIS"."DOMAIN_WTRNETTYPE" ("TYPE") DISABLE;
ALTER TABLE "GIS"."WATERFEATURE" ADD CONSTRAINT "FK_20_DOMAIN_UTILITYDATAQUALI"
FOREIGN KEY ("QUALITYLEVEL")
REFERENCES "GIS"."DOMAIN_UTILITYDATAQUALITY" ("TYPE") DISABLE;
ALTER TABLE "GIS"."WATERFEATURE" ADD CONSTRAINT "FK_24_DOMAIN_UTILOPSTAT" FOREIGN KEY
("OPERATIONALSTATUS")
REFERENCES "GIS"."DOMAIN_UTILOPSTAT" ("TYPE") DISABLE;
ALTER TABLE "GIS"."WATERFEATURE" ADD CONSTRAINT "FK_25_DOMAIN_UTILITYINVESTATI"
FOREIGN KEY ("INVESTIGATIONLEVEL")
REFERENCES "GIS"."DOMAIN_UTILITYINVESTATIONLEVEL" ("TYPE") DISABLE;
ALTER TABLE "GIS"."WATERFEATURE" ADD CONSTRAINT "FK_42_DOMAIN_RES" FOREIGN KEY
("RESOLUTION")
REFERENCES "GIS"."DOMAIN_UTILITYRESOLUTIONS" ("TYPE") DISABLE;
ALTER TABLE "GIS"."WATERFEATURE" ADD CONSTRAINT "FK_42_DOMAIN_RESSTATUS" FOREIGN KEY
("RESOLUTIONSTATUS")
REFERENCES "GIS"."DOMAIN_UTILITYRESOLUTIONSTATUS" ("TYPE") DISABLE;
-----
-- Ref Constraints for Table SITE
-----
ALTER TABLE "GIS"."SITE" ADD CONSTRAINT "FK_14_DOMAIN_UTILITYDATAQUALI" FOREIGN KEY
("QUALITYLEVEL")
REFERENCES "GIS"."DOMAIN_UTILITYDATAQUALITY" ("TYPE") DISABLE;
ALTER TABLE "GIS"."SITE" ADD CONSTRAINT "FK_21_DOMAIN_UTILOPSTAT" FOREIGN KEY
("OPERATIONALSTATUS")

```

```

REFERENCES "GIS"."DOMAIN_UTILLOPSTAT" ("TYPE") DISABLE;
ALTER TABLE "GIS"."SITE" ADD CONSTRAINT "FK_29_DOMAIN_RES" FOREIGN KEY ("RESOLUTION")
REFERENCES "GIS"."DOMAIN_UTILITYRESOLUTIONS" ("TYPE") DISABLE;
ALTER TABLE "GIS"."SITE" ADD CONSTRAINT "FK_29_DOMAIN_RESSTATUS" FOREIGN KEY
("RESOLUTIONSTATUS")
REFERENCES "GIS"."DOMAIN_UTILITYRESOLUTIONSTATUS" ("TYPE") DISABLE;
ALTER TABLE "GIS"."SITE" ADD CONSTRAINT "FK_31_DOMAIN_UTILITYINVESTATI" FOREIGN KEY
("INVESTIGATIONLEVEL")
REFERENCES "GIS"."DOMAIN_UTILITYINVESTATIONLEVEL" ("TYPE") DISABLE;

```

```
-- Ref Constraints for Table EXTERNALPROPERTYINTEREST
```

```

ALTER TABLE "GIS"."EXTERNALPROPERTYINTEREST" ADD CONSTRAINT
"FK_0_DOMAIN_EXTERNALINTEREST" FOREIGN KEY ("INTERESTTYPE")
REFERENCES "GIS"."DOMAIN_EXTERNALINTERESTTYPE" ("TYPE") DISABLE;
ALTER TABLE "GIS"."EXTERNALPROPERTYINTEREST" ADD CONSTRAINT "FK_11_DOMAIN_RES"
FOREIGN KEY ("RESOLUTION")
REFERENCES "GIS"."DOMAIN_UTILITYRESOLUTIONS" ("TYPE") DISABLE;
ALTER TABLE "GIS"."EXTERNALPROPERTYINTEREST" ADD CONSTRAINT "FK_11_DOMAIN_RESSTATUS"
FOREIGN KEY ("RESOLUTIONSTATUS")
REFERENCES "GIS"."DOMAIN_UTILITYRESOLUTIONSTATUS" ("TYPE") DISABLE;
ALTER TABLE "GIS"."EXTERNALPROPERTYINTEREST" ADD CONSTRAINT
"FK_30_DOMAIN_UTILITYDATAQUALI" FOREIGN KEY ("QUALITYLEVEL")
REFERENCES "GIS"."DOMAIN_UTILITYDATAQUALITY" ("TYPE") DISABLE;
ALTER TABLE "GIS"."EXTERNALPROPERTYINTEREST" ADD CONSTRAINT
"FK_30_DOMAIN_UTILITYINVESTATI" FOREIGN KEY ("INVESTIGATIONLEVEL")
REFERENCES "GIS"."DOMAIN_UTILITYINVESTATIONLEVEL" ("TYPE") DISABLE;
ALTER TABLE "GIS"."EXTERNALPROPERTYINTEREST" ADD CONSTRAINT
"FK_33_DOMAIN_UTILLOPSTAT" FOREIGN KEY ("OPERATIONALSTATUS")
REFERENCES "GIS"."DOMAIN_UTILLOPSTAT" ("TYPE") DISABLE;

```

```
-- Ref Constraints for Table CONFLICTNODE
```

```

ALTER TABLE "GIS"."CONFLICTNODE" ADD CONSTRAINT "FK_0_DOMAIN_CONFLICTRESOL" FOREIGN
KEY ("RECOMMENDATION")
REFERENCES "GIS"."DOMAIN_CONFLICTRESOL" ("TYPE") DISABLE;
ALTER TABLE "GIS"."CONFLICTNODE" ADD CONSTRAINT "FK_0_DOMAIN_CONFLICTTYPE" FOREIGN
KEY ("CONFLICTTYPE")
REFERENCES "GIS"."DOMAIN_CONFLICTTYPE" ("TYPE") DISABLE;
ALTER TABLE "GIS"."CONFLICTNODE" ADD CONSTRAINT "FK_1_DOMAIN_CONFLICTRESOL" FOREIGN
KEY ("RESOLUTION")
REFERENCES "GIS"."DOMAIN_CONFLICTRESOL" ("TYPE") DISABLE;
ALTER TABLE "GIS"."CONFLICTNODE" ADD CONSTRAINT "FK_45_DOMAIN_UTILLOPSTAT" FOREIGN KEY
("CURRENTSTATUS")
REFERENCES "GIS"."DOMAIN_UTILLOPSTAT" ("TYPE") DISABLE;

```

```
-- Ref Constraints for Table ELEVATIONCONTOUR
```

```

ALTER TABLE "GIS"."ELEVATIONCONTOUR" ADD CONSTRAINT "FK_0_DOMAIN_ELEVATIONCONTOUR"
FOREIGN KEY ("ELEVCONTOURTYPE")
REFERENCES "GIS"."DOMAIN_ELEVATIONCONTOURTYPE" ("TYPE") DISABLE;
ALTER TABLE "GIS"."ELEVATIONCONTOUR" ADD CONSTRAINT "FK_10_DOMAIN_RES" FOREIGN KEY
("RESOLUTION")
REFERENCES "GIS"."DOMAIN_UTILITYRESOLUTIONS" ("TYPE") DISABLE;
ALTER TABLE "GIS"."ELEVATIONCONTOUR" ADD CONSTRAINT "FK_10_DOMAIN_RESSTATUS" FOREIGN
KEY ("RESOLUTIONSTATUS")

```



```

REFERENCES "GIS"."DOMAIN_UTILITYRESOLUTIONSTATUS" ("TYPE") DISABLE;
ALTER TABLE "GIS"."ELEVATIONCONTOUR" ADD CONSTRAINT "FK_3_DOMAIN_UTILLOPSTAT" FOREIGN
KEY ("OPERATIONALSTATUS")
REFERENCES "GIS"."DOMAIN_UTILLOPSTAT" ("TYPE") DISABLE;
ALTER TABLE "GIS"."ELEVATIONCONTOUR" ADD CONSTRAINT "FK_5_DOMAIN_GSIP_LENGTHUOM"
FOREIGN KEY ("ELEVATIONUOM")
REFERENCES "GIS"."DOMAIN_GSIP_LENGTHUOM" ("TYPE") DISABLE;
ALTER TABLE "GIS"."ELEVATIONCONTOUR" ADD CONSTRAINT "FK_5_DOMAIN_UTILITYDATAQUALI"
FOREIGN KEY ("QUALITYLEVEL")
REFERENCES "GIS"."DOMAIN_UTILITYDATAQUALITY" ("TYPE") DISABLE;
ALTER TABLE "GIS"."ELEVATIONCONTOUR" ADD CONSTRAINT "FK_9_DOMAIN_UTILITYINVESTATI"
FOREIGN KEY ("INVESTIGATIONLEVEL")
REFERENCES "GIS"."DOMAIN_UTILITYINVESTATIONLEVEL" ("TYPE") DISABLE;

```

```
-- Ref Constraints for Table SURVEYJOB
```

```

ALTER TABLE "GIS"."SURVEYJOB" ADD CONSTRAINT "FK_31_DOMAIN_RES" FOREIGN KEY
("RESOLUTION")
REFERENCES "GIS"."DOMAIN_UTILITYRESOLUTIONS" ("TYPE") DISABLE;
ALTER TABLE "GIS"."SURVEYJOB" ADD CONSTRAINT "FK_31_DOMAIN_RESSTATUS" FOREIGN KEY
("RESOLUTIONSTATUS")
REFERENCES "GIS"."DOMAIN_UTILITYRESOLUTIONSTATUS" ("TYPE") DISABLE;
ALTER TABLE "GIS"."SURVEYJOB" ADD CONSTRAINT "FK_44_DOMAIN_SURVEYMETHOD" FOREIGN KEY
("SURVEYMETHOD")
REFERENCES "GIS"."DOMAIN_SURVEYMETHOD" ("TYPE") DISABLE;
ALTER TABLE "GIS"."SURVEYJOB" ADD CONSTRAINT "FK_44_DOMAIN_SURVEYTYPE" FOREIGN KEY
("SURVEYTYPE")
REFERENCES "GIS"."DOMAIN_SURVEYTYPE" ("TYPE") DISABLE;
ALTER TABLE "GIS"."SURVEYJOB" ADD CONSTRAINT "FK_44_DOMAIN_UTILITYDATAQUALI" FOREIGN
KEY ("QUALITYLEVEL")
REFERENCES "GIS"."DOMAIN_UTILITYDATAQUALITY" ("TYPE") DISABLE;
ALTER TABLE "GIS"."SURVEYJOB" ADD CONSTRAINT "FK_44_DOMAIN_UTILITYINVESTATI" FOREIGN
KEY ("INVESTIGATIONLEVEL")
REFERENCES "GIS"."DOMAIN_UTILITYINVESTATIONLEVEL" ("TYPE") DISABLE;
ALTER TABLE "GIS"."SURVEYJOB" ADD CONSTRAINT "FK_44_DOMAIN_UTILLOPSTAT" FOREIGN KEY
("OPERATIONALSTATUS")
REFERENCES "GIS"."DOMAIN_UTILLOPSTAT" ("TYPE") DISABLE;

```

```
-- Ref Constraints for Table RESTRICTEDAREA
```

```

ALTER TABLE "GIS"."RESTRICTEDAREA" ADD CONSTRAINT "FK_26_DOMAIN_RES" FOREIGN KEY
("RESOLUTION")
REFERENCES "GIS"."DOMAIN_UTILITYRESOLUTIONS" ("TYPE") DISABLE;
ALTER TABLE "GIS"."RESTRICTEDAREA" ADD CONSTRAINT "FK_26_DOMAIN_RESSTATUS" FOREIGN
KEY ("RESOLUTIONSTATUS")
REFERENCES "GIS"."DOMAIN_UTILITYRESOLUTIONSTATUS" ("TYPE") DISABLE;
ALTER TABLE "GIS"."RESTRICTEDAREA" ADD CONSTRAINT "FK_33_DOMAIN_UTILITYINVESTATI"
FOREIGN KEY ("INVESTIGATIONLEVEL")
REFERENCES "GIS"."DOMAIN_UTILITYINVESTATIONLEVEL" ("TYPE") DISABLE;
ALTER TABLE "GIS"."RESTRICTEDAREA" ADD CONSTRAINT "FK_35_DOMAIN_UTILLOPSTAT" FOREIGN
KEY ("OPERATIONALSTATUS")
REFERENCES "GIS"."DOMAIN_UTILLOPSTAT" ("TYPE") DISABLE;
ALTER TABLE "GIS"."RESTRICTEDAREA" ADD CONSTRAINT "FK_39_DOMAIN_UTILITYDATAQUALI"
FOREIGN KEY ("QUALITYLEVEL")
REFERENCES "GIS"."DOMAIN_UTILITYDATAQUALITY" ("TYPE") DISABLE;

```

```
-- Ref Constraints for Table RECREATIONAREA
```

```
-----
ALTER TABLE "GIS"."RECREATIONAREA" ADD CONSTRAINT "FK_0_DOMAIN_RECREATIONAREATY"
FOREIGN KEY ("AREATYPE")
REFERENCES "GIS"."DOMAIN_RECREATIONAREATYPE" ("TYPE") DISABLE;
ALTER TABLE "GIS"."RECREATIONAREA" ADD CONSTRAINT "FK_20_DOMAIN_UTILLOPSTAT" FOREIGN
KEY ("OPERATIONALSTATUS")
REFERENCES "GIS"."DOMAIN_UTILLOPSTAT" ("TYPE") DISABLE;
ALTER TABLE "GIS"."RECREATIONAREA" ADD CONSTRAINT "FK_24_DOMAIN_RES" FOREIGN KEY
("RESOLUTION")
REFERENCES "GIS"."DOMAIN_UTILITYRESOLUTIONS" ("TYPE") DISABLE;
ALTER TABLE "GIS"."RECREATIONAREA" ADD CONSTRAINT "FK_24_DOMAIN_RESSTATUS" FOREIGN
KEY ("RESOLUTIONSTATUS")
REFERENCES "GIS"."DOMAIN_UTILITYRESOLUTIONSTATUS" ("TYPE") DISABLE;
ALTER TABLE "GIS"."RECREATIONAREA" ADD CONSTRAINT "FK_6_DOMAIN_UTILITYINVESTATI"
FOREIGN KEY ("INVESTIGATIONLEVEL")
REFERENCES "GIS"."DOMAIN_UTILITYINVESTATIONLEVEL" ("TYPE") DISABLE;
ALTER TABLE "GIS"."RECREATIONAREA" ADD CONSTRAINT "FK_7_DOMAIN_UTILITYDATAQUALI"
FOREIGN KEY ("QUALITYLEVEL")
REFERENCES "GIS"."DOMAIN_UTILITYDATAQUALITY" ("TYPE") DISABLE;
-----
```

```
-- Ref Constraints for Table INSTALLATION
```

```
-----
ALTER TABLE "GIS"."INSTALLATION" ADD CONSTRAINT "FK_16_DOMAIN_UTILITYDATAQUALI"
FOREIGN KEY ("QUALITYLEVEL")
REFERENCES "GIS"."DOMAIN_UTILITYDATAQUALITY" ("TYPE") DISABLE;
ALTER TABLE "GIS"."INSTALLATION" ADD CONSTRAINT "FK_17_DOMAIN_RES" FOREIGN KEY
("RESOLUTION")
REFERENCES "GIS"."DOMAIN_UTILITYRESOLUTIONS" ("TYPE") DISABLE;
ALTER TABLE "GIS"."INSTALLATION" ADD CONSTRAINT "FK_17_DOMAIN_RESSTATUS" FOREIGN KEY
("RESOLUTIONSTATUS")
REFERENCES "GIS"."DOMAIN_UTILITYRESOLUTIONSTATUS" ("TYPE") DISABLE;
ALTER TABLE "GIS"."INSTALLATION" ADD CONSTRAINT "FK_25_DOMAIN_UTILLOPSTAT" FOREIGN KEY
("OPERATIONALSTATUS")
REFERENCES "GIS"."DOMAIN_UTILLOPSTAT" ("TYPE") DISABLE;
ALTER TABLE "GIS"."INSTALLATION" ADD CONSTRAINT "FK_35_DOMAIN_UTILITYINVESTATI"
FOREIGN KEY ("INVESTIGATIONLEVEL")
REFERENCES "GIS"."DOMAIN_UTILITYINVESTATIONLEVEL" ("TYPE") DISABLE;
-----
```

```
-- Ref Constraints for Table CONTROLMONUMENTPOINT
```

```
-----
ALTER TABLE "GIS"."CONTROLMONUMENTPOINT" ADD CONSTRAINT
"FK_0_DOMAIN_COORDINATESYSTEM" FOREIGN KEY ("COORDINATESYSTEM")
REFERENCES "GIS"."DOMAIN_COORDINATESYSTEM" ("TYPE") DISABLE;
ALTER TABLE "GIS"."CONTROLMONUMENTPOINT" ADD CONSTRAINT
"FK_0_DOMAIN_HORIZONTALDATUMT" FOREIGN KEY ("HORIZONTALDATUM")
REFERENCES "GIS"."DOMAIN_HORIZONTALDATUMTYPE" ("TYPE") DISABLE;
ALTER TABLE "GIS"."CONTROLMONUMENTPOINT" ADD CONSTRAINT
"FK_0_DOMAIN_MONUMENTPOINTTYP" FOREIGN KEY ("MONUMENTPOINTTYP")
REFERENCES "GIS"."DOMAIN_MONUMENTPOINTTYPE" ("TYPE") DISABLE;
ALTER TABLE "GIS"."CONTROLMONUMENTPOINT" ADD CONSTRAINT
"FK_0_DOMAIN_VERTICALDATUMTYP" FOREIGN KEY ("COLLECTIONVERTICALDATUM")
REFERENCES "GIS"."DOMAIN_VERTICALDATUMTYPE" ("TYPE") DISABLE;
ALTER TABLE "GIS"."CONTROLMONUMENTPOINT" ADD CONSTRAINT
"FK_2_DOMAIN_UTILITYDATAQUALI" FOREIGN KEY ("QUALITYLEVEL")
REFERENCES "GIS"."DOMAIN_UTILITYDATAQUALITY" ("TYPE") DISABLE;
-----
```

```

ALTER TABLE "GIS"."CONTROLMONUMENTPOINT" ADD CONSTRAINT
"FK_4_DOMAIN_UTILITYINVESTATI" FOREIGN KEY ("INVESTIGATIONLEVEL")
REFERENCES "GIS"."DOMAIN_UTILITYINVESTATIONLEVEL" ("TYPE") DISABLE;
ALTER TABLE "GIS"."CONTROLMONUMENTPOINT" ADD CONSTRAINT "FK_5_DOMAIN_RES" FOREIGN KEY
("RESOLUTION")
REFERENCES "GIS"."DOMAIN_UTILITYRESOLUTIONS" ("TYPE") DISABLE;
ALTER TABLE "GIS"."CONTROLMONUMENTPOINT" ADD CONSTRAINT "FK_5_DOMAIN_RESSTATUS"
FOREIGN KEY ("RESOLUTIONSTATUS")
REFERENCES "GIS"."DOMAIN_UTILITYRESOLUTIONSTATUS" ("TYPE") DISABLE;
ALTER TABLE "GIS"."CONTROLMONUMENTPOINT" ADD CONSTRAINT "FK_5_DOMAIN_UTILOPSTAT"
FOREIGN KEY ("OPERATIONALSTATUS")
REFERENCES "GIS"."DOMAIN_UTILOPSTAT" ("TYPE") DISABLE;
-----
-- Ref Constraints for Table WASTEWATERNODE
-----
ALTER TABLE "GIS"."WASTEWATERNODE" ADD CONSTRAINT "FK_0_DOMAIN_WWNDETYPE" FOREIGN KEY
("WWATERNODETYPE")
REFERENCES "GIS"."DOMAIN_WWNDETYPE" ("TYPE") DISABLE;
ALTER TABLE "GIS"."WASTEWATERNODE" ADD CONSTRAINT "FK_0_DOMAIN_WWNETTYPE" FOREIGN KEY
("WWATERNETWORKTYPE")
REFERENCES "GIS"."DOMAIN_WWNETTYPE" ("TYPE") DISABLE;
ALTER TABLE "GIS"."WASTEWATERNODE" ADD CONSTRAINT "FK_18_DOMAIN_UTILITYINVESTATI"
FOREIGN KEY ("INVESTIGATIONLEVEL")
REFERENCES "GIS"."DOMAIN_UTILITYINVESTATIONLEVEL" ("TYPE") DISABLE;
ALTER TABLE "GIS"."WASTEWATERNODE" ADD CONSTRAINT "FK_1_DOMAIN_FITTYPE" FOREIGN KEY
("FITTINGTYPE")
REFERENCES "GIS"."DOMAIN_FITTYPE" ("TYPE") DISABLE;
ALTER TABLE "GIS"."WASTEWATERNODE" ADD CONSTRAINT "FK_1_DOMAIN_VOLTYPE" FOREIGN KEY
("VOLUMETYPE")
REFERENCES "GIS"."DOMAIN_VOLTYPE" ("TYPE") DISABLE;
ALTER TABLE "GIS"."WASTEWATERNODE" ADD CONSTRAINT "FK_23_DOMAIN_UTILITYDATAQUALI"
FOREIGN KEY ("QUALITYLEVEL")
REFERENCES "GIS"."DOMAIN_UTILITYDATAQUALITY" ("TYPE") DISABLE;
ALTER TABLE "GIS"."WASTEWATERNODE" ADD CONSTRAINT "FK_26_DOMAIN_UTILOPSTAT" FOREIGN
KEY ("OPERATIONALSTATUS")
REFERENCES "GIS"."DOMAIN_UTILOPSTAT" ("TYPE") DISABLE;
ALTER TABLE "GIS"."WASTEWATERNODE" ADD CONSTRAINT "FK_39_DOMAIN_RES" FOREIGN KEY
("RESOLUTION")
REFERENCES "GIS"."DOMAIN_UTILITYRESOLUTIONS" ("TYPE") DISABLE;
ALTER TABLE "GIS"."WASTEWATERNODE" ADD CONSTRAINT "FK_39_DOMAIN_RESSTATUS" FOREIGN
KEY ("RESOLUTIONSTATUS")
REFERENCES "GIS"."DOMAIN_UTILITYRESOLUTIONSTATUS" ("TYPE") DISABLE;
ALTER TABLE "GIS"."WASTEWATERNODE" ADD CONSTRAINT "FK_5_DOMAIN_UTLNDETYPE" FOREIGN
KEY ("UTILITYNODETYPE")
REFERENCES "GIS"."DOMAIN_UTLNDETYPE" ("TYPE") DISABLE;
ALTER TABLE "GIS"."WASTEWATERNODE" ADD CONSTRAINT "FK_6_DOMAIN_NDESHPTYPE" FOREIGN
KEY ("NODESHAPETYPE")
REFERENCES "GIS"."DOMAIN_NDESHPTYPE" ("TYPE") DISABLE;
-----
-- Ref Constraints for Table TRANSPORTATIONTUNNEL
-----
ALTER TABLE "GIS"."TRANSPORTATIONTUNNEL" ADD CONSTRAINT
"FK_0_DOMAIN_TRANSTUNNELTYPE" FOREIGN KEY ("TUNNELTYPE")
REFERENCES "GIS"."DOMAIN_TRANSTUNNELTYPE" ("TYPE") DISABLE;
ALTER TABLE "GIS"."TRANSPORTATIONTUNNEL" ADD CONSTRAINT
"FK_13_DOMAIN_UTILITYDATAQUALI" FOREIGN KEY ("QUALITYLEVEL")

```

```

REFERENCES "GIS"."DOMAIN_UTILITYDATAQUALITY" ("TYPE") DISABLE;
ALTER TABLE "GIS"."TRANSPORTATIONTUNNEL" ADD CONSTRAINT "FK_14_DOMAIN_UTILOPSTAT"
FOREIGN KEY ("OPERATIONALSTATUS")
REFERENCES "GIS"."DOMAIN_UTILOPSTAT" ("TYPE") DISABLE;
ALTER TABLE "GIS"."TRANSPORTATIONTUNNEL" ADD CONSTRAINT
"FK_24_DOMAIN_UTILITYINVESTATI" FOREIGN KEY ("INVESTIGATIONLEVEL")
REFERENCES "GIS"."DOMAIN_UTILITYINVESTATIONLEVEL" ("TYPE") DISABLE;
ALTER TABLE "GIS"."TRANSPORTATIONTUNNEL" ADD CONSTRAINT "FK_36_DOMAIN_RES" FOREIGN
KEY ("RESOLUTION")
REFERENCES "GIS"."DOMAIN_UTILITYRESOLUTIONS" ("TYPE") DISABLE;
ALTER TABLE "GIS"."TRANSPORTATIONTUNNEL" ADD CONSTRAINT "FK_36_DOMAIN_RESSTATUS"
FOREIGN KEY ("RESOLUTIONSTATUS")
REFERENCES "GIS"."DOMAIN_UTILITYRESOLUTIONSTATUS" ("TYPE") DISABLE;

```

```
-- Ref Constraints for Table POLSEGMENT
```

```

ALTER TABLE "GIS"."POLSEGMENT" ADD CONSTRAINT "FK_0_DOMAIN_POLSEGTYPE" FOREIGN KEY
("POLSEGMENTTYPE")
REFERENCES "GIS"."DOMAIN_POLSEGTYPE" ("TYPE") DISABLE;
ALTER TABLE "GIS"."POLSEGMENT" ADD CONSTRAINT "FK_1_DOMAIN_PIPEMATERIAL" FOREIGN KEY
("MATERIAL")
REFERENCES "GIS"."DOMAIN_PIPEMATERIAL" ("TYPE") DISABLE;
ALTER TABLE "GIS"."POLSEGMENT" ADD CONSTRAINT "FK_1_DOMAIN_POLNETTYPE" FOREIGN KEY
("POLNETWORKTYPE")
REFERENCES "GIS"."DOMAIN_POLNETTYPE" ("TYPE") DISABLE;
ALTER TABLE "GIS"."POLSEGMENT" ADD CONSTRAINT "FK_21_DOMAIN_RES" FOREIGN KEY
("RESOLUTION")
REFERENCES "GIS"."DOMAIN_UTILITYRESOLUTIONS" ("TYPE") DISABLE;
ALTER TABLE "GIS"."POLSEGMENT" ADD CONSTRAINT "FK_21_DOMAIN_RESSTATUS" FOREIGN KEY
("RESOLUTIONSTATUS")
REFERENCES "GIS"."DOMAIN_UTILITYRESOLUTIONSTATUS" ("TYPE") DISABLE;
ALTER TABLE "GIS"."POLSEGMENT" ADD CONSTRAINT "FK_23_DOMAIN_UTILITYINVESTATI"
FOREIGN KEY ("INVESTIGATIONLEVEL")
REFERENCES "GIS"."DOMAIN_UTILITYINVESTATIONLEVEL" ("TYPE") DISABLE;
ALTER TABLE "GIS"."POLSEGMENT" ADD CONSTRAINT "FK_2_DOMAIN_SEGSHPTYPE" FOREIGN KEY
("SEGMENTSHAPETYPE")
REFERENCES "GIS"."DOMAIN_SEGSHPTYPE" ("TYPE") DISABLE;
ALTER TABLE "GIS"."POLSEGMENT" ADD CONSTRAINT "FK_6_DOMAIN_SEGTYPE" FOREIGN KEY
("SEGMENTTYPE")
REFERENCES "GIS"."DOMAIN_SEGTYPE" ("TYPE") DISABLE;
ALTER TABLE "GIS"."POLSEGMENT" ADD CONSTRAINT "FK_6_DOMAIN_UTILITYDATAQUALI" FOREIGN
KEY ("QUALITYLEVEL")
REFERENCES "GIS"."DOMAIN_UTILITYDATAQUALITY" ("TYPE") DISABLE;
ALTER TABLE "GIS"."POLSEGMENT" ADD CONSTRAINT "FK_6_DOMAIN_UTILOPSTAT" FOREIGN KEY
("OPERATIONALSTATUS")
REFERENCES "GIS"."DOMAIN_UTILOPSTAT" ("TYPE") DISABLE;

```

```
-- Ref Constraints for Table THERMALNODE
```

```

ALTER TABLE "GIS"."THERMALNODE" ADD CONSTRAINT "FK_0_DOMAIN_THMNODTYPE" FOREIGN KEY
("THERMNODETYPE")
REFERENCES "GIS"."DOMAIN_THMNODTYPE" ("TYPE") DISABLE;
ALTER TABLE "GIS"."THERMALNODE" ADD CONSTRAINT "FK_1_DOMAIN_THMNETTYPE" FOREIGN KEY
("THERMNETWORKTYPE")
REFERENCES "GIS"."DOMAIN_THMNETTYPE" ("TYPE") DISABLE;

```

```

ALTER TABLE "GIS"."THERMALNODE" ADD CONSTRAINT "FK_25_DOMAIN_UTILITYDATAQUALI"
FOREIGN KEY ("QUALITYLEVEL")
REFERENCES "GIS"."DOMAIN_UTILITYDATAQUALITY" ("TYPE") DISABLE;
ALTER TABLE "GIS"."THERMALNODE" ADD CONSTRAINT "FK_2_DOMAIN_FITTYPE" FOREIGN KEY
("FITTINGTYPE")
REFERENCES "GIS"."DOMAIN_FITTYPE" ("TYPE") DISABLE;
ALTER TABLE "GIS"."THERMALNODE" ADD CONSTRAINT "FK_2_DOMAIN_UTILOPSTAT" FOREIGN KEY
("OPERATIONALSTATUS")
REFERENCES "GIS"."DOMAIN_UTILOPSTAT" ("TYPE") DISABLE;
ALTER TABLE "GIS"."THERMALNODE" ADD CONSTRAINT "FK_33_DOMAIN_RES" FOREIGN KEY
("RESOLUTION")
REFERENCES "GIS"."DOMAIN_UTILITYRESOLUTIONS" ("TYPE") DISABLE;
ALTER TABLE "GIS"."THERMALNODE" ADD CONSTRAINT "FK_33_DOMAIN_RESSTATUS" FOREIGN KEY
("RESOLUTIONSTATUS")
REFERENCES "GIS"."DOMAIN_UTILITYRESOLUTIONSTATUS" ("TYPE") DISABLE;
ALTER TABLE "GIS"."THERMALNODE" ADD CONSTRAINT "FK_36_DOMAIN_UTILITYINVESTATI"
FOREIGN KEY ("INVESTIGATIONLEVEL")
REFERENCES "GIS"."DOMAIN_UTILITYINVESTATIONLEVEL" ("TYPE") DISABLE;
ALTER TABLE "GIS"."THERMALNODE" ADD CONSTRAINT "FK_3_DOMAIN_UTLNDETYPE" FOREIGN KEY
("UTILITYNODETYPE")
REFERENCES "GIS"."DOMAIN_UTLNDETYPE" ("TYPE") DISABLE;
ALTER TABLE "GIS"."THERMALNODE" ADD CONSTRAINT "FK_4_DOMAIN_NDESHPTYPE" FOREIGN KEY
("NODESHAPETYPE")
REFERENCES "GIS"."DOMAIN_NDESHPTYPE" ("TYPE") DISABLE;
ALTER TABLE "GIS"."THERMALNODE" ADD CONSTRAINT "FK_5_DOMAIN_VOLTYPE" FOREIGN KEY
("VOLUMETYPE")
REFERENCES "GIS"."DOMAIN_VOLTYPE" ("TYPE") DISABLE;
-----
-- Ref Constraints for Table ELECCONDUITBANKSEGMENT
-----
ALTER TABLE "GIS"."ELECCONDUITBANKSEGMENT" ADD CONSTRAINT "FK_0_DOMAIN_ENETTYPE"
FOREIGN KEY ("ELECNETWORKTYPE")
REFERENCES "GIS"."DOMAIN_ENETTYPE" ("TYPE") DISABLE;
ALTER TABLE "GIS"."ELECCONDUITBANKSEGMENT" ADD CONSTRAINT "FK_0_DOMAIN_SEGTYPE"
FOREIGN KEY ("SEGMENTTYPE")
REFERENCES "GIS"."DOMAIN_SEGTYPE" ("TYPE") DISABLE;
ALTER TABLE "GIS"."ELECCONDUITBANKSEGMENT" ADD CONSTRAINT "FK_19_DOMAIN_UTILOPSTAT"
FOREIGN KEY ("OPERATIONALSTATUS")
REFERENCES "GIS"."DOMAIN_UTILOPSTAT" ("TYPE") DISABLE;
ALTER TABLE "GIS"."ELECCONDUITBANKSEGMENT" ADD CONSTRAINT "FK_1_DOMAIN_ESEGTYPE"
FOREIGN KEY ("ELECSEGMENTTYPE")
REFERENCES "GIS"."DOMAIN_ESEGTYPE" ("TYPE") DISABLE;
ALTER TABLE "GIS"."ELECCONDUITBANKSEGMENT" ADD CONSTRAINT
"FK_24_DOMAIN_UTILITYDATAQUALI" FOREIGN KEY ("QUALITYLEVEL")
REFERENCES "GIS"."DOMAIN_UTILITYDATAQUALITY" ("TYPE") DISABLE;
ALTER TABLE "GIS"."ELECCONDUITBANKSEGMENT" ADD CONSTRAINT
"FK_2_DOMAIN_UTILITYINVESTATI" FOREIGN KEY ("INVESTIGATIONLEVEL")
REFERENCES "GIS"."DOMAIN_UTILITYINVESTATIONLEVEL" ("TYPE") DISABLE;
ALTER TABLE "GIS"."ELECCONDUITBANKSEGMENT" ADD CONSTRAINT "FK_3_DOMAIN_SEGSHPTYPE"
FOREIGN KEY ("SEGMENTSHAPETYPE")
REFERENCES "GIS"."DOMAIN_SEGSHPTYPE" ("TYPE") DISABLE;
ALTER TABLE "GIS"."ELECCONDUITBANKSEGMENT" ADD CONSTRAINT "FK_7_DOMAIN_PIPEMATERIAL"
FOREIGN KEY ("MATERIAL")
REFERENCES "GIS"."DOMAIN_PIPEMATERIAL" ("TYPE") DISABLE;
ALTER TABLE "GIS"."ELECCONDUITBANKSEGMENT" ADD CONSTRAINT "FK_7_DOMAIN_RES" FOREIGN
KEY ("RESOLUTION")

```

```

REFERENCES "GIS"."DOMAIN_UTILITYRESOLUTIONS" ("TYPE") DISABLE;
ALTER TABLE "GIS"."ELECCONDUITBANKSEGMENT" ADD CONSTRAINT "FK_7_DOMAIN_RESSTATUS"
FOREIGN KEY ("RESOLUTIONSTATUS")
REFERENCES "GIS"."DOMAIN_UTILITYRESOLUTIONSTATUS" ("TYPE") DISABLE;
-----
-- Ref Constraints for Table WATERNODE
-----
ALTER TABLE "GIS"."WATERNODE" ADD CONSTRAINT "FK_0_DOMAIN_NDESHPTYPE" FOREIGN KEY
("NODESHAPETYPE")
REFERENCES "GIS"."DOMAIN_NDESHPTYPE" ("TYPE") DISABLE;
ALTER TABLE "GIS"."WATERNODE" ADD CONSTRAINT "FK_18_DOMAIN_UTILOPSTAT" FOREIGN KEY
("OPERATIONALSTATUS")
REFERENCES "GIS"."DOMAIN_UTILOPSTAT" ("TYPE") DISABLE;
ALTER TABLE "GIS"."WATERNODE" ADD CONSTRAINT "FK_1_DOMAIN_UTLNDETYPE" FOREIGN KEY
("UTILITYNODETYPE")
REFERENCES "GIS"."DOMAIN_UTLNDETYPE" ("TYPE") DISABLE;
ALTER TABLE "GIS"."WATERNODE" ADD CONSTRAINT "FK_1_DOMAIN_WTRNDETYPE" FOREIGN KEY
("WATERNODETYPE")
REFERENCES "GIS"."DOMAIN_WTRNDETYPE" ("TYPE") DISABLE;
ALTER TABLE "GIS"."WATERNODE" ADD CONSTRAINT "FK_1_DOMAIN_WTRNETTYPE" FOREIGN KEY
("WATERNETWORKTYPE")
REFERENCES "GIS"."DOMAIN_WTRNETTYPE" ("TYPE") DISABLE;
ALTER TABLE "GIS"."WATERNODE" ADD CONSTRAINT "FK_28_DOMAIN_UTILITYINVESTATI" FOREIGN
KEY ("INVESTIGATIONLEVEL")
REFERENCES "GIS"."DOMAIN_UTILITYINVESTATIONLEVEL" ("TYPE") DISABLE;
ALTER TABLE "GIS"."WATERNODE" ADD CONSTRAINT "FK_2_DOMAIN_VOLTYPE" FOREIGN KEY
("VOLUMETYPE")
REFERENCES "GIS"."DOMAIN_VOLTYPE" ("TYPE") DISABLE;
ALTER TABLE "GIS"."WATERNODE" ADD CONSTRAINT "FK_43_DOMAIN_RES" FOREIGN KEY
("RESOLUTION")
REFERENCES "GIS"."DOMAIN_UTILITYRESOLUTIONS" ("TYPE") DISABLE;
ALTER TABLE "GIS"."WATERNODE" ADD CONSTRAINT "FK_43_DOMAIN_RESSTATUS" FOREIGN KEY
("RESOLUTIONSTATUS")
REFERENCES "GIS"."DOMAIN_UTILITYRESOLUTIONSTATUS" ("TYPE") DISABLE;
ALTER TABLE "GIS"."WATERNODE" ADD CONSTRAINT "FK_6_DOMAIN_FITTYPE" FOREIGN KEY
("FITTINGTYPE")
REFERENCES "GIS"."DOMAIN_FITTYPE" ("TYPE") DISABLE;
ALTER TABLE "GIS"."WATERNODE" ADD CONSTRAINT "FK_9_DOMAIN_UTILITYDATAQUALI" FOREIGN
KEY ("QUALITYLEVEL")
REFERENCES "GIS"."DOMAIN_UTILITYDATAQUALITY" ("TYPE") DISABLE;
-----
-- Ref Constraints for Table PROJECTREFERENCE
-----
ALTER TABLE "GIS"."PROJECTREFERENCE" ADD CONSTRAINT "FK_16_DOMAIN_UTILOPSTAT"
FOREIGN KEY ("OPERATIONALSTATUS")
REFERENCES "GIS"."DOMAIN_UTILOPSTAT" ("TYPE") DISABLE;
ALTER TABLE "GIS"."PROJECTREFERENCE" ADD CONSTRAINT "FK_22_DOMAIN_RES" FOREIGN KEY
("RESOLUTION")
REFERENCES "GIS"."DOMAIN_UTILITYRESOLUTIONS" ("TYPE") DISABLE;
ALTER TABLE "GIS"."PROJECTREFERENCE" ADD CONSTRAINT "FK_22_DOMAIN_RESSTATUS" FOREIGN
KEY ("RESOLUTIONSTATUS")
REFERENCES "GIS"."DOMAIN_UTILITYRESOLUTIONSTATUS" ("TYPE") DISABLE;
ALTER TABLE "GIS"."PROJECTREFERENCE" ADD CONSTRAINT "FK_29_DOMAIN_UTILITYINVESTATI"
FOREIGN KEY ("INVESTIGATIONLEVEL")
REFERENCES "GIS"."DOMAIN_UTILITYINVESTATIONLEVEL" ("TYPE") DISABLE;

```

```
ALTER TABLE "GIS"."PROJECTREFERENCE" ADD CONSTRAINT "FK_31_DOMAIN_UTILITYDATAQUALI"
FOREIGN KEY ("QUALITYLEVEL")
REFERENCES "GIS"."DOMAIN_UTILITYDATAQUALITY" ("TYPE") DISABLE;
```

```
-----
-- Ref Constraints for Table DOTPERMIT
-----
```

```
ALTER TABLE "GIS"."DOTPERMIT" ADD CONSTRAINT "FK_19_DOMAIN_UTILITYDATAQUALI" FOREIGN
KEY ("QUALITYLEVEL")
REFERENCES "GIS"."DOMAIN_UTILITYDATAQUALITY" ("TYPE") DISABLE;
ALTER TABLE "GIS"."DOTPERMIT" ADD CONSTRAINT "FK_32_DOMAIN_UTILITYINVESTATI" FOREIGN
KEY ("INVESTIGATIONLEVEL")
REFERENCES "GIS"."DOMAIN_UTILITYINVESTATIONLEVEL" ("TYPE") DISABLE;
ALTER TABLE "GIS"."DOTPERMIT" ADD CONSTRAINT "FK_4_DOMAIN_UTILOPSTAT" FOREIGN KEY
("OPERATIONSTATUS")
REFERENCES "GIS"."DOMAIN_UTILOPSTAT" ("TYPE") DISABLE;
ALTER TABLE "GIS"."DOTPERMIT" ADD CONSTRAINT "FK_6_DOMAIN_RES" FOREIGN KEY
("RESOLUTION")
REFERENCES "GIS"."DOMAIN_UTILITYRESOLUTIONS" ("TYPE") DISABLE;
ALTER TABLE "GIS"."DOTPERMIT" ADD CONSTRAINT "FK_6_DOMAIN_RESSTATUS" FOREIGN KEY
("RESOLUTIONSTATUS")
REFERENCES "GIS"."DOMAIN_UTILITYRESOLUTIONSTATUS" ("TYPE") DISABLE;
```

```
-----
-- Ref Constraints for Table WASTEWATERSEGMENT
-----
```

```
ALTER TABLE "GIS"."WASTEWATERSEGMENT" ADD CONSTRAINT "FK_0_DOMAIN_PIPEMATERIAL"
FOREIGN KEY ("MATERIAL")
REFERENCES "GIS"."DOMAIN_PIPEMATERIAL" ("TYPE") DISABLE;
ALTER TABLE "GIS"."WASTEWATERSEGMENT" ADD CONSTRAINT "FK_0_DOMAIN_WWSEGTYPE" FOREIGN
KEY ("WWATERSEGMENTTYPE")
REFERENCES "GIS"."DOMAIN_WWSEGTYPE" ("TYPE") DISABLE;
ALTER TABLE "GIS"."WASTEWATERSEGMENT" ADD CONSTRAINT "FK_14_DOMAIN_UTILITYINVESTATI"
FOREIGN KEY ("INVESTIGATIONLEVEL")
REFERENCES "GIS"."DOMAIN_UTILITYINVESTATIONLEVEL" ("TYPE") DISABLE;
ALTER TABLE "GIS"."WASTEWATERSEGMENT" ADD CONSTRAINT "FK_1_DOMAIN_WWNETTYPE" FOREIGN
KEY ("WWATERNETWORKTYPE")
REFERENCES "GIS"."DOMAIN_WWNETTYPE" ("TYPE") DISABLE;
ALTER TABLE "GIS"."WASTEWATERSEGMENT" ADD CONSTRAINT "FK_21_DOMAIN_UTILITYDATAQUALI"
FOREIGN KEY ("QUALITYLEVEL")
REFERENCES "GIS"."DOMAIN_UTILITYDATAQUALITY" ("TYPE") DISABLE;
ALTER TABLE "GIS"."WASTEWATERSEGMENT" ADD CONSTRAINT "FK_30_DOMAIN_UTILOPSTAT"
FOREIGN KEY ("OPERATIONALSTATUS")
REFERENCES "GIS"."DOMAIN_UTILOPSTAT" ("TYPE") DISABLE;
ALTER TABLE "GIS"."WASTEWATERSEGMENT" ADD CONSTRAINT "FK_40_DOMAIN_RES" FOREIGN KEY
("RESOLUTION")
REFERENCES "GIS"."DOMAIN_UTILITYRESOLUTIONS" ("TYPE") DISABLE;
ALTER TABLE "GIS"."WASTEWATERSEGMENT" ADD CONSTRAINT "FK_40_DOMAIN_RESSTATUS"
FOREIGN KEY ("RESOLUTIONSTATUS")
REFERENCES "GIS"."DOMAIN_UTILITYRESOLUTIONSTATUS" ("TYPE") DISABLE;
```

```
-----
-- Ref Constraints for Table PAVEMENTSECTION
-----
```

```
ALTER TABLE "GIS"."PAVEMENTSECTION" ADD CONSTRAINT "FK_19_DOMAIN_RES" FOREIGN KEY
("RESOLUTION")
REFERENCES "GIS"."DOMAIN_UTILITYRESOLUTIONS" ("TYPE") DISABLE;
ALTER TABLE "GIS"."PAVEMENTSECTION" ADD CONSTRAINT "FK_19_DOMAIN_RESSTATUS" FOREIGN
KEY ("RESOLUTIONSTATUS")
```

```

REFERENCES "GIS"."DOMAIN_UTILITYRESOLUTIONSTATUS" ("TYPE") DISABLE;
ALTER TABLE "GIS"."PAVEMENTSECTION" ADD CONSTRAINT "FK_41_DOMAIN_PAVEMENTSECTIONT"
FOREIGN KEY ("PAVEMENTSECTIONTYPE")
REFERENCES "GIS"."DOMAIN_PAVEMENTSECTIONT" ("TYPE") DISABLE;
ALTER TABLE "GIS"."PAVEMENTSECTION" ADD CONSTRAINT "FK_41_DOMAIN_UTILITYDATAQUALI"
FOREIGN KEY ("QUALITYLEVEL")
REFERENCES "GIS"."DOMAIN_UTILITYDATAQUALITY" ("TYPE") DISABLE;
ALTER TABLE "GIS"."PAVEMENTSECTION" ADD CONSTRAINT "FK_41_DOMAIN_UTILITYINVESTATI"
FOREIGN KEY ("INVESTIGATIONLEVEL")
REFERENCES "GIS"."DOMAIN_UTILITYINVESTATIONLEVEL" ("TYPE") DISABLE;
ALTER TABLE "GIS"."PAVEMENTSECTION" ADD CONSTRAINT "FK_41_DOMAIN_UTILIOSTAT" FOREIGN
KEY ("OPERATIONALSTATUS")
REFERENCES "GIS"."DOMAIN_UTILIOSTAT" ("TYPE") DISABLE;

```

```
-- Ref Constraints for Table WALL
```

```

ALTER TABLE "GIS"."WALL" ADD CONSTRAINT "FK_0_DOMAIN_GSIP_LENGTHUOM" FOREIGN KEY
("WALLHEIGHTUOM")
REFERENCES "GIS"."DOMAIN_GSIP_LENGTHUOM" ("TYPE") DISABLE;
ALTER TABLE "GIS"."WALL" ADD CONSTRAINT "FK_0_DOMAIN_WALLTYPE" FOREIGN KEY
("WALLTYPE")
REFERENCES "GIS"."DOMAIN_WALLTYPE" ("TYPE") DISABLE;
ALTER TABLE "GIS"."WALL" ADD CONSTRAINT "FK_11_DOMAIN_UTILIOSTAT" FOREIGN KEY
("OPERATIONALSTATUS")
REFERENCES "GIS"."DOMAIN_UTILIOSTAT" ("TYPE") DISABLE;
ALTER TABLE "GIS"."WALL" ADD CONSTRAINT "FK_37_DOMAIN_UTILITYINVESTATI" FOREIGN KEY
("INVESTIGATIONLEVEL")
REFERENCES "GIS"."DOMAIN_UTILITYINVESTATIONLEVEL" ("TYPE") DISABLE;
ALTER TABLE "GIS"."WALL" ADD CONSTRAINT "FK_38_DOMAIN_RES" FOREIGN KEY ("RESOLUTION")
REFERENCES "GIS"."DOMAIN_UTILITYRESOLUTIONS" ("TYPE") DISABLE;
ALTER TABLE "GIS"."WALL" ADD CONSTRAINT "FK_38_DOMAIN_RESSTATUS" FOREIGN KEY
("RESOLUTIONSTATUS")
REFERENCES "GIS"."DOMAIN_UTILITYRESOLUTIONSTATUS" ("TYPE") DISABLE;
ALTER TABLE "GIS"."WALL" ADD CONSTRAINT "FK_8_DOMAIN_UTILITYDATAQUALI" FOREIGN KEY
("QUALITYLEVEL")
REFERENCES "GIS"."DOMAIN_UTILITYDATAQUALITY" ("TYPE") DISABLE;

```

```
-- Ref Constraints for Table WATERSEGMENT
```

```

ALTER TABLE "GIS"."WATERSEGMENT" ADD CONSTRAINT "FK_0_DOMAIN_WTRSEGTYPE" FOREIGN KEY
("WATERSEGMENTTYPE")
REFERENCES "GIS"."DOMAIN_WTRSEGTYPE" ("TYPE") DISABLE;
ALTER TABLE "GIS"."WATERSEGMENT" ADD CONSTRAINT "FK_1_DOMAIN_UTILITYINVESTATI"
FOREIGN KEY ("INVESTIGATIONLEVEL")
REFERENCES "GIS"."DOMAIN_UTILITYINVESTATIONLEVEL" ("TYPE") DISABLE;
ALTER TABLE "GIS"."WATERSEGMENT" ADD CONSTRAINT "FK_2_DOMAIN_WTRNETTYPE" FOREIGN KEY
("WATERNETWORKTYPE")
REFERENCES "GIS"."DOMAIN_WTRNETTYPE" ("TYPE") DISABLE;
ALTER TABLE "GIS"."WATERSEGMENT" ADD CONSTRAINT "FK_32_DOMAIN_UTILITYDATAQUALI"
FOREIGN KEY ("QUALITYLEVEL")
REFERENCES "GIS"."DOMAIN_UTILITYDATAQUALITY" ("TYPE") DISABLE;
ALTER TABLE "GIS"."WATERSEGMENT" ADD CONSTRAINT "FK_39_DOMAIN_UTILIOSTAT" FOREIGN KEY
("OPERATIONALSTATUS")
REFERENCES "GIS"."DOMAIN_UTILIOSTAT" ("TYPE") DISABLE;
ALTER TABLE "GIS"."WATERSEGMENT" ADD CONSTRAINT "FK_44_DOMAIN_RES" FOREIGN KEY
("RESOLUTION")

```



```

REFERENCES "GIS"."DOMAIN_UTILITYRESOLUTIONS" ("TYPE") DISABLE;
ALTER TABLE "GIS"."WATERSEGMENT" ADD CONSTRAINT "FK_44_DOMAIN_RESSTATUS" FOREIGN KEY
("RESOLUTIONSTATUS")
REFERENCES "GIS"."DOMAIN_UTILITYRESOLUTIONSTATUS" ("TYPE") DISABLE;
ALTER TABLE "GIS"."WATERSEGMENT" ADD CONSTRAINT "FK_5_DOMAIN_PIPEMATERIAL" FOREIGN
KEY ("MATERIAL")
REFERENCES "GIS"."DOMAIN_PIPEMATERIAL" ("TYPE") DISABLE;
ALTER TABLE "GIS"."WATERSEGMENT" ADD CONSTRAINT "FK_5_DOMAIN_SEGTYPE" FOREIGN KEY
("SEGMENTTYPE")
REFERENCES "GIS"."DOMAIN_SEGTYPE" ("TYPE") DISABLE;
ALTER TABLE "GIS"."WATERSEGMENT" ADD CONSTRAINT "FK_6_DOMAIN_SEGSHPTYPE" FOREIGN KEY
("SEGMENTSHAPETYPE")
REFERENCES "GIS"."DOMAIN_SEGSHPTYPE" ("TYPE") DISABLE;

```

```
-- Ref Constraints for Table GRID
```

```

ALTER TABLE "GIS"."GRID" ADD CONSTRAINT "FK_15_DOMAIN_RES" FOREIGN KEY ("RESOLUTION")
REFERENCES "GIS"."DOMAIN_UTILITYRESOLUTIONS" ("TYPE") DISABLE;
ALTER TABLE "GIS"."GRID" ADD CONSTRAINT "FK_15_DOMAIN_RESSTATUS" FOREIGN KEY
("RESOLUTIONSTATUS")
REFERENCES "GIS"."DOMAIN_UTILITYRESOLUTIONSTATUS" ("TYPE") DISABLE;
ALTER TABLE "GIS"."GRID" ADD CONSTRAINT "FK_22_DOMAIN_UTILITYDATAQUALI" FOREIGN KEY
("QUALITYLEVEL")
REFERENCES "GIS"."DOMAIN_UTILITYDATAQUALITY" ("TYPE") DISABLE;
ALTER TABLE "GIS"."GRID" ADD CONSTRAINT "FK_34_DOMAIN_UTILITYINVESTATI" FOREIGN KEY
("INVESTIGATIONLEVEL")
REFERENCES "GIS"."DOMAIN_UTILITYINVESTATIONLEVEL" ("TYPE") DISABLE;
ALTER TABLE "GIS"."GRID" ADD CONSTRAINT "FK_8_DOMAIN_UTILOPSTAT" FOREIGN KEY
("OPERATIONALSTATUS")
REFERENCES "GIS"."DOMAIN_UTILOPSTAT" ("TYPE") DISABLE;

```

```
-- Ref Constraints for Table ELECTRICALSEGMENT
```

```

ALTER TABLE "GIS"."ELECTRICALSEGMENT" ADD CONSTRAINT "FK_0_DOMAIN_ESEGTYPE" FOREIGN
KEY ("ELECSEGMENTTYPE")
REFERENCES "GIS"."DOMAIN_ESEGTYPE" ("TYPE") DISABLE;
ALTER TABLE "GIS"."ELECTRICALSEGMENT" ADD CONSTRAINT "FK_0_DOMAIN_SEGSHPTYPE"
FOREIGN KEY ("SEGMENTSHAPETYPE")
REFERENCES "GIS"."DOMAIN_SEGSHPTYPE" ("TYPE") DISABLE;
ALTER TABLE "GIS"."ELECTRICALSEGMENT" ADD CONSTRAINT "FK_17_DOMAIN_UTILITYINVESTATI"
FOREIGN KEY ("INVESTIGATIONLEVEL")
REFERENCES "GIS"."DOMAIN_UTILITYINVESTATIONLEVEL" ("TYPE") DISABLE;
ALTER TABLE "GIS"."ELECTRICALSEGMENT" ADD CONSTRAINT "FK_1_DOMAIN_ENETTYPE" FOREIGN
KEY ("ELECNETWORKTYPE")
REFERENCES "GIS"."DOMAIN_ENETTYPE" ("TYPE") DISABLE;
ALTER TABLE "GIS"."ELECTRICALSEGMENT" ADD CONSTRAINT "FK_2_DOMAIN_PIPEMATERIAL"
FOREIGN KEY ("MATERIAL")
REFERENCES "GIS"."DOMAIN_PIPEMATERIAL" ("TYPE") DISABLE;
ALTER TABLE "GIS"."ELECTRICALSEGMENT" ADD CONSTRAINT "FK_36_DOMAIN_UTILITYDATAQUALI"
FOREIGN KEY ("QUALITYLEVEL")
REFERENCES "GIS"."DOMAIN_UTILITYDATAQUALITY" ("TYPE") DISABLE;
ALTER TABLE "GIS"."ELECTRICALSEGMENT" ADD CONSTRAINT "FK_36_DOMAIN_UTILOPSTAT"
FOREIGN KEY ("OPERATIONALSTATUS")
REFERENCES "GIS"."DOMAIN_UTILOPSTAT" ("TYPE") DISABLE;
ALTER TABLE "GIS"."ELECTRICALSEGMENT" ADD CONSTRAINT "FK_4_DOMAIN_SEGTYPE" FOREIGN
KEY ("SEGMENTTYPE")

```



```

REFERENCES "GIS"."DOMAIN_SEGTYPE" ("TYPE") DISABLE;
ALTER TABLE "GIS"."ELECTRICALSEGMENT" ADD CONSTRAINT "FK_9_DOMAIN_RES" FOREIGN KEY
("RESOLUTION")
REFERENCES "GIS"."DOMAIN_UTILITYRESOLUTIONS" ("TYPE") DISABLE;
ALTER TABLE "GIS"."ELECTRICALSEGMENT" ADD CONSTRAINT "FK_9_DOMAIN_RESSTATUS" FOREIGN
KEY ("RESOLUTIONSTATUS")
REFERENCES "GIS"."DOMAIN_UTILITYRESOLUTIONSTATUS" ("TYPE") DISABLE;
-----
-- Ref Constraints for Table RECREATIONFEATURE
-----
ALTER TABLE "GIS"."RECREATIONFEATURE" ADD CONSTRAINT "FK_13_DOMAIN_UTILLOPSTAT"
FOREIGN KEY ("OPERATIONALSTATUS")
REFERENCES "GIS"."DOMAIN_UTILLOPSTAT" ("TYPE") DISABLE;
ALTER TABLE "GIS"."RECREATIONFEATURE" ADD CONSTRAINT "FK_16_DOMAIN_UTILITYINVESTATI"
FOREIGN KEY ("INVESTIGATIONLEVEL")
REFERENCES "GIS"."DOMAIN_UTILITYINVESTATIONLEVEL" ("TYPE") DISABLE;
ALTER TABLE "GIS"."RECREATIONFEATURE" ADD CONSTRAINT "FK_25_DOMAIN_RES" FOREIGN KEY
("RESOLUTION")
REFERENCES "GIS"."DOMAIN_UTILITYRESOLUTIONS" ("TYPE") DISABLE;
ALTER TABLE "GIS"."RECREATIONFEATURE" ADD CONSTRAINT "FK_25_DOMAIN_RESSTATUS"
FOREIGN KEY ("RESOLUTIONSTATUS")
REFERENCES "GIS"."DOMAIN_UTILITYRESOLUTIONSTATUS" ("TYPE") DISABLE;
ALTER TABLE "GIS"."RECREATIONFEATURE" ADD CONSTRAINT "FK_26_DOMAIN_UTILITYDATAQUALI"
FOREIGN KEY ("QUALITYLEVEL")
REFERENCES "GIS"."DOMAIN_UTILITYDATAQUALITY" ("TYPE") DISABLE;
-----
-- Ref Constraints for Table COMMUNICATIONNODE
-----
ALTER TABLE "GIS"."COMMUNICATIONNODE" ADD CONSTRAINT "FK_0_DOMAIN_COMNDETYPE"
FOREIGN KEY ("COMMNODETYPE")
REFERENCES "GIS"."DOMAIN_COMNDETYPE" ("TYPE") DISABLE;
ALTER TABLE "GIS"."COMMUNICATIONNODE" ADD CONSTRAINT "FK_0_DOMAIN_COMNETTYPE"
FOREIGN KEY ("COMMNETWORKTYPE")
REFERENCES "GIS"."DOMAIN_COMNETTYPE" ("TYPE") DISABLE;
ALTER TABLE "GIS"."COMMUNICATIONNODE" ADD CONSTRAINT "FK_10_DOMAIN_UTILITYINVESTATI"
FOREIGN KEY ("INVESTIGATIONLEVEL")
REFERENCES "GIS"."DOMAIN_UTILITYINVESTATIONLEVEL" ("TYPE") DISABLE;
ALTER TABLE "GIS"."COMMUNICATIONNODE" ADD CONSTRAINT "FK_12_DOMAIN_UTILITYDATAQUALI"
FOREIGN KEY ("QUALITYLEVEL")
REFERENCES "GIS"."DOMAIN_UTILITYDATAQUALITY" ("TYPE") DISABLE;
ALTER TABLE "GIS"."COMMUNICATIONNODE" ADD CONSTRAINT "FK_15_DOMAIN_UTILLOPSTAT"
FOREIGN KEY ("OPERATIONALSTATUS")
REFERENCES "GIS"."DOMAIN_UTILLOPSTAT" ("TYPE") DISABLE;
ALTER TABLE "GIS"."COMMUNICATIONNODE" ADD CONSTRAINT "FK_1_DOMAIN_NDESHPTYPE"
FOREIGN KEY ("NODESHAPETYPE")
REFERENCES "GIS"."DOMAIN_NDESHPTYPE" ("TYPE") DISABLE;
ALTER TABLE "GIS"."COMMUNICATIONNODE" ADD CONSTRAINT "FK_2_DOMAIN_RES" FOREIGN KEY
("RESOLUTION")
REFERENCES "GIS"."DOMAIN_UTILITYRESOLUTIONS" ("TYPE") DISABLE;
ALTER TABLE "GIS"."COMMUNICATIONNODE" ADD CONSTRAINT "FK_2_DOMAIN_RESSTATUS" FOREIGN
KEY ("RESOLUTIONSTATUS")
REFERENCES "GIS"."DOMAIN_UTILITYRESOLUTIONSTATUS" ("TYPE") DISABLE;
ALTER TABLE "GIS"."COMMUNICATIONNODE" ADD CONSTRAINT "FK_5_DOMAIN_FITTYPE" FOREIGN
KEY ("FITTINGTYPE")
REFERENCES "GIS"."DOMAIN_FITTYPE" ("TYPE") DISABLE;

```

```

ALTER TABLE "GIS"."COMMUNICATIONNODE" ADD CONSTRAINT "FK_6_DOMAIN_UTLNDETYPE"
FOREIGN KEY ("UTILITYNODETYPE")
REFERENCES "GIS"."DOMAIN_UTLNDETYPE" ("TYPE") DISABLE;
ALTER TABLE "GIS"."COMMUNICATIONNODE" ADD CONSTRAINT "FK_6_DOMAIN_VOLTYPE" FOREIGN
KEY ("VOLUMETYPE")
REFERENCES "GIS"."DOMAIN_VOLTYPE" ("TYPE") DISABLE;

```

```
-- Ref Constraints for Table POLNODE
```

```

ALTER TABLE "GIS"."POLNODE" ADD CONSTRAINT "FK_0_DOMAIN_POLNDETYPE" FOREIGN KEY
("POLNODETYPE")
REFERENCES "GIS"."DOMAIN_POLNDETYPE" ("TYPE") DISABLE;
ALTER TABLE "GIS"."POLNODE" ADD CONSTRAINT "FK_0_DOMAIN_POLNETTYPE" FOREIGN KEY
("POLNETWORKTYPE")
REFERENCES "GIS"."DOMAIN_POLNETTYPE" ("TYPE") DISABLE;
ALTER TABLE "GIS"."POLNODE" ADD CONSTRAINT "FK_0_DOMAIN_UTLNDETYPE" FOREIGN KEY
("UTILITYNODETYPE")
REFERENCES "GIS"."DOMAIN_UTLNDETYPE" ("TYPE") DISABLE;
ALTER TABLE "GIS"."POLNODE" ADD CONSTRAINT "FK_10_DOMAIN_UTILLOPSTAT" FOREIGN KEY
("OPERATIONALSTATUS")
REFERENCES "GIS"."DOMAIN_UTILLOPSTAT" ("TYPE") DISABLE;
ALTER TABLE "GIS"."POLNODE" ADD CONSTRAINT "FK_15_DOMAIN_UTILITYINVESTATI" FOREIGN
KEY ("INVESTIGATIONLEVEL")
REFERENCES "GIS"."DOMAIN_UTILITYINVESTATIONLEVEL" ("TYPE") DISABLE;
ALTER TABLE "GIS"."POLNODE" ADD CONSTRAINT "FK_20_DOMAIN_RES" FOREIGN KEY
("RESOLUTION")
REFERENCES "GIS"."DOMAIN_UTILITYRESOLUTIONS" ("TYPE") DISABLE;
ALTER TABLE "GIS"."POLNODE" ADD CONSTRAINT "FK_20_DOMAIN_RESSTATUS" FOREIGN KEY
("RESOLUTIONSTATUS")
REFERENCES "GIS"."DOMAIN_UTILITYRESOLUTIONSTATUS" ("TYPE") DISABLE;
ALTER TABLE "GIS"."POLNODE" ADD CONSTRAINT "FK_35_DOMAIN_UTILITYDATAQUALI" FOREIGN
KEY ("QUALITYLEVEL")
REFERENCES "GIS"."DOMAIN_UTILITYDATAQUALITY" ("TYPE") DISABLE;
ALTER TABLE "GIS"."POLNODE" ADD CONSTRAINT "FK_4_DOMAIN_FITTYPE" FOREIGN KEY
("FITTINGTYPE")
REFERENCES "GIS"."DOMAIN_FITTYPE" ("TYPE") DISABLE;
ALTER TABLE "GIS"."POLNODE" ADD CONSTRAINT "FK_4_DOMAIN_VOLTYPE" FOREIGN KEY
("VOLUMETYPE")
REFERENCES "GIS"."DOMAIN_VOLTYPE" ("TYPE") DISABLE;
ALTER TABLE "GIS"."POLNODE" ADD CONSTRAINT "FK_5_DOMAIN_NDESHPTYPE" FOREIGN KEY
("NODESHAPETYPE")
REFERENCES "GIS"."DOMAIN_NDESHPTYPE" ("TYPE") DISABLE;

```

```
-- Ref Constraints for Table RAILTRACK
```

```

ALTER TABLE "GIS"."RAILTRACK" ADD CONSTRAINT "FK_0_DOMAIN_RAILCONSTRUCTION" FOREIGN
KEY ("RAILCONSTRUCTIONTYPE")
REFERENCES "GIS"."DOMAIN_RAILCONSTRUCTIONTYPE" ("TYPE") DISABLE;
ALTER TABLE "GIS"."RAILTRACK" ADD CONSTRAINT "FK_17_DOMAIN_UTILLOPSTAT" FOREIGN KEY
("OPERATIONALSTATUS")
REFERENCES "GIS"."DOMAIN_UTILLOPSTAT" ("TYPE") DISABLE;
ALTER TABLE "GIS"."RAILTRACK" ADD CONSTRAINT "FK_23_DOMAIN_RES" FOREIGN KEY
("RESOLUTION")
REFERENCES "GIS"."DOMAIN_UTILITYRESOLUTIONS" ("TYPE") DISABLE;
ALTER TABLE "GIS"."RAILTRACK" ADD CONSTRAINT "FK_23_DOMAIN_RESSTATUS" FOREIGN KEY
("RESOLUTIONSTATUS")

```

```

REFERENCES "GIS"."DOMAIN_UTILITYRESOLUTIONSTATUS" ("TYPE") DISABLE;
ALTER TABLE "GIS"."RAILTRACK" ADD CONSTRAINT "FK_27_DOMAIN_UTILITYINVESTATI" FOREIGN
KEY ("INVESTIGATIONLEVEL")
REFERENCES "GIS"."DOMAIN_UTILITYINVESTATIONLEVEL" ("TYPE") DISABLE;
ALTER TABLE "GIS"."RAILTRACK" ADD CONSTRAINT "FK_34_DOMAIN_UTILITYDATAQUALI" FOREIGN
KEY ("QUALITYLEVEL")
REFERENCES "GIS"."DOMAIN_UTILITYDATAQUALITY" ("TYPE") DISABLE;

```

```
-- Spatial Index
```

```

INSERT INTO MDSYS.SDO_COORD_REF_SYSTEM (
  SRID,
  COORD_REF_SYS_NAME,
  COORD_REF_SYS_KIND,
  COORD_SYS_ID,
  DATUM_ID,
  SOURCE_GEOG_SRID,
  PROJECTION_CONV_ID,
  CMPD_HORIZ_SRID,
  CMPD_VERT_SRID,
  INFORMATION_SOURCE,
  DATA_SOURCE,
  IS_LEGACY,
  LEGACY_CODE,
  LEGACY_WKTEXT,
  LEGACY_CS_BOUNDS)
VALUES (
  9989,
  'NAD83(HARN) / Virginia North (ftUS)',
  'COMPOUND',
  NULL,
  NULL,
  NULL,
  NULL,
  2924,
  5701,
  NULL,
  'EPSG',
  'FALSE',
  NULL,
  NULL,
  NULL);

DELETE FROM USER_SDO_GEOM_METADATA WHERE TABLE_NAME = 'GIS_BRIDGE' AND COLUMN_NAME =
'OGC_GEOMETRY';
INSERT INTO USER_SDO_GEOM_METADATA (TABLE_NAME, COLUMN_NAME, DIMINFO, SRID)
VALUES ('GIS_BRIDGE', 'OGC_GEOMETRY',
MDSYS.SDO_DIM_ARRAY
(
  MDSYS.SDO_DIM_ELEMENT('X', 0, 999999, 0.000000005),
  MDSYS.SDO_DIM_ELEMENT('Y', 0, 999999, 0.000000005),
  MDSYS.SDO_DIM_ELEMENT('Z', -500000, 500000, 0.000000005)
),

```

```
9989);
```

```
CREATE INDEX GIS_BRIDGE_SIDX ON GIS_BRIDGE(OGC_GEOMETRY) INDEXTYPE IS
MDSYS.SPATIAL_INDEX PARAMETERS('layer_gtype=multipolygon');
```

```
DELETE FROM USER_SDO_GEOM_METADATA WHERE TABLE_NAME = 'GIS_BUILDING' AND COLUMN_NAME
= 'OGC_GEOMETRY';
```

```
INSERT INTO USER_SDO_GEOM_METADATA (TABLE_NAME, COLUMN_NAME, DIMINFO, SRID)
VALUES ('GIS_BUILDING', 'OGC_GEOMETRY',
MDSYS.SDO_DIM_ARRAY
(
MDSYS.SDO_DIM_ELEMENT('X', 0, 999999, 0.0000000005),
MDSYS.SDO_DIM_ELEMENT('Y', 0, 999999, 0.0000000005),
MDSYS.SDO_DIM_ELEMENT('Z', -500000, 500000, 0.0000000005)
),
9989);
```

```
CREATE INDEX GIS_BUILDING_SIDX ON GIS_BUILDING(OGC_GEOMETRY) INDEXTYPE IS
MDSYS.SPATIAL_INDEX PARAMETERS('layer_gtype=multipolygon');
```

```
DELETE FROM USER_SDO_GEOM_METADATA WHERE TABLE_NAME = 'GIS_COMMUNICATIONNODE' AND
COLUMN_NAME = 'OGC_GEOMETRY';
```

```
INSERT INTO USER_SDO_GEOM_METADATA (TABLE_NAME, COLUMN_NAME, DIMINFO, SRID)
VALUES ('GIS_COMMUNICATIONNODE', 'OGC_GEOMETRY',
MDSYS.SDO_DIM_ARRAY
(
MDSYS.SDO_DIM_ELEMENT('X', 0, 999999, 0.0000000005),
MDSYS.SDO_DIM_ELEMENT('Y', 0, 999999, 0.0000000005),
MDSYS.SDO_DIM_ELEMENT('Z', -500000, 500000, 0.0000000005)
),
9989);
```

```
CREATE INDEX GIS_COMMUNICATIONNODE_SIDX ON GIS_COMMUNICATIONNODE(OGC_GEOMETRY)
INDEXTYPE IS MDSYS.SPATIAL_INDEX PARAMETERS('layer_gtype=point');
```

```
DELETE FROM USER_SDO_GEOM_METADATA WHERE TABLE_NAME = 'GIS_COMMUNICATIONSEGMENT' AND
COLUMN_NAME = 'OGC_GEOMETRY';
```

```
INSERT INTO USER_SDO_GEOM_METADATA (TABLE_NAME, COLUMN_NAME, DIMINFO, SRID)
VALUES ('GIS_COMMUNICATIONSEGMENT', 'OGC_GEOMETRY',
MDSYS.SDO_DIM_ARRAY
(
MDSYS.SDO_DIM_ELEMENT('X', 0, 999999, 0.0000000005),
MDSYS.SDO_DIM_ELEMENT('Y', 0, 999999, 0.0000000005),
MDSYS.SDO_DIM_ELEMENT('Z', -500000, 500000, 0.0000000005)
),
9989);
```

```
CREATE INDEX GIS_COMMUNICATIONSEGMENT_SIDX ON GIS_COMMUNICATIONSEGMENT(OGC_GEOMETRY)
INDEXTYPE IS MDSYS.SPATIAL_INDEX PARAMETERS('layer_gtype=curve');
```

```
DELETE FROM USER_SDO_GEOM_METADATA WHERE TABLE_NAME = 'GIS_CONFLICTNODE' AND
COLUMN_NAME = 'OGC_GEOMETRY';
```

```
INSERT INTO USER_SDO_GEOM_METADATA (TABLE_NAME, COLUMN_NAME, DIMINFO, SRID)
VALUES ('GIS_CONFLICTNODE', 'OGC_GEOMETRY',
MDSYS.SDO_DIM_ARRAY
(
```

```

MDSYS.SDO_DIM_ELEMENT('X', 0, 999999, 0.0000000005),
MDSYS.SDO_DIM_ELEMENT('Y', 0, 999999, 0.0000000005),
MDSYS.SDO_DIM_ELEMENT('Z', -500000, 500000, 0.0000000005)
),
9989);

```

```

CREATE INDEX GIS_CONFLICTNODE_SIDX ON GIS_CONFLICTNODE(OGC_GEOMETRY) INDEXTYPE IS
MDSYS.SPATIAL_INDEX PARAMETERS('layer_gtype=point');

```

```

DELETE FROM USER_SDO_GEOM_METADATA WHERE TABLE_NAME = 'GIS_CONSTRUCTIONLINE' AND
COLUMN_NAME = 'OGC_GEOMETRY';

```

```

INSERT INTO USER_SDO_GEOM_METADATA (TABLE_NAME, COLUMN_NAME, DIMINFO, SRID)
VALUES ('GIS_CONSTRUCTIONLINE', 'OGC_GEOMETRY',
MDSYS.SDO_DIM_ARRAY
(
MDSYS.SDO_DIM_ELEMENT('X', 0, 999999, 0.0000000005),
MDSYS.SDO_DIM_ELEMENT('Y', 0, 999999, 0.0000000005),
MDSYS.SDO_DIM_ELEMENT('Z', -500000, 500000, 0.0000000005)
),
9989);

```

```

CREATE INDEX GIS_CONSTRUCTIONLINE_SIDX ON GIS_CONSTRUCTIONLINE(OGC_GEOMETRY) INDEXTYPE
IS MDSYS.SPATIAL_INDEX PARAMETERS('layer_gtype=curve');

```

```

DELETE FROM USER_SDO_GEOM_METADATA WHERE TABLE_NAME = 'GIS_CONTROLMONUMENTPOINT' AND
COLUMN_NAME = 'OGC_GEOMETRY';

```

```

INSERT INTO USER_SDO_GEOM_METADATA (TABLE_NAME, COLUMN_NAME, DIMINFO, SRID)
VALUES ('GIS_CONTROLMONUMENTPOINT', 'OGC_GEOMETRY',
MDSYS.SDO_DIM_ARRAY
(
MDSYS.SDO_DIM_ELEMENT('X', 0, 999999, 0.0000000005),
MDSYS.SDO_DIM_ELEMENT('Y', 0, 999999, 0.0000000005),
MDSYS.SDO_DIM_ELEMENT('Z', -500000, 500000, 0.0000000005)
),
9989);

```

```

CREATE INDEX GIS_CONTROLMONUMENTPOINT_SIDX ON GIS_CONTROLMONUMENTPOINT(OGC_GEOMETRY)
INDEXTYPE IS MDSYS.SPATIAL_INDEX PARAMETERS('layer_gtype=point');

```

```

DELETE FROM USER_SDO_GEOM_METADATA WHERE TABLE_NAME = 'GIS_DOTPERMIT' AND COLUMN_NAME
= 'OGC_GEOMETRY';

```

```

INSERT INTO USER_SDO_GEOM_METADATA (TABLE_NAME, COLUMN_NAME, DIMINFO, SRID)
VALUES ('GIS_DOTPERMIT', 'OGC_GEOMETRY',
MDSYS.SDO_DIM_ARRAY
(
MDSYS.SDO_DIM_ELEMENT('X', 0, 999999, 0.0000000005),
MDSYS.SDO_DIM_ELEMENT('Y', 0, 999999, 0.0000000005),
MDSYS.SDO_DIM_ELEMENT('Z', -500000, 500000, 0.0000000005)
),
9989);

```

```

CREATE INDEX GIS_DOTPERMIT_SIDX ON GIS_DOTPERMIT(OGC_GEOMETRY) INDEXTYPE IS
MDSYS.SPATIAL_INDEX PARAMETERS('layer_gtype=multipolygon');

```

```

DELETE FROM USER_SDO_GEOM_METADATA WHERE TABLE_NAME = 'GIS_ELECCONDUITBANKSEGMENT' AND
COLUMN_NAME = 'OGC_GEOMETRY';

```

```

INSERT INTO USER_SDO_GEOM_METADATA (TABLE_NAME, COLUMN_NAME, DIMINFO, SRID)
VALUES ('GIS_ELECCONDUITBANKSEGMENT', 'OGC_GEOMETRY',
MDSYS.SDO_DIM_ARRAY
(
MDSYS.SDO_DIM_ELEMENT('X', 0, 999999, 0.0000000005),
MDSYS.SDO_DIM_ELEMENT('Y', 0, 999999, 0.0000000005),
MDSYS.SDO_DIM_ELEMENT('Z', -500000, 500000, 0.0000000005)
),
9989);

```

```

CREATE INDEX GIS_ELECCONDUITBANKSEGMENT_SIDX ON
GIS_ELECCONDUITBANKSEGMENT(OGC_GEOMETRY) INDEXTYPE IS MDSYS.SPATIAL_INDEX
PARAMETERS('layer_gtype=curve');

```

```

DELETE FROM USER_SDO_GEOM_METADATA WHERE TABLE_NAME = 'GIS_ELECTRICALNODE' AND
COLUMN_NAME = 'OGC_GEOMETRY';

```

```

INSERT INTO USER_SDO_GEOM_METADATA (TABLE_NAME, COLUMN_NAME, DIMINFO, SRID)
VALUES ('GIS_ELECTRICALNODE', 'OGC_GEOMETRY',
MDSYS.SDO_DIM_ARRAY
(
MDSYS.SDO_DIM_ELEMENT('X', 0, 999999, 0.0000000005),
MDSYS.SDO_DIM_ELEMENT('Y', 0, 999999, 0.0000000005),
MDSYS.SDO_DIM_ELEMENT('Z', -500000, 500000, 0.0000000005)
),
9989);

```

```

CREATE INDEX GIS_ELECTRICALNODE_SIDX ON GIS_ELECTRICALNODE(OGC_GEOMETRY) INDEXTYPE IS
MDSYS.SPATIAL_INDEX PARAMETERS('layer_gtype=point');

```

```

DELETE FROM USER_SDO_GEOM_METADATA WHERE TABLE_NAME = 'GIS_ELECTRICALSEGMENT' AND
COLUMN_NAME = 'OGC_GEOMETRY';

```

```

INSERT INTO USER_SDO_GEOM_METADATA (TABLE_NAME, COLUMN_NAME, DIMINFO, SRID)
VALUES ('GIS_ELECTRICALSEGMENT', 'OGC_GEOMETRY',
MDSYS.SDO_DIM_ARRAY
(
MDSYS.SDO_DIM_ELEMENT('X', 0, 999999, 0.0000000005),
MDSYS.SDO_DIM_ELEMENT('Y', 0, 999999, 0.0000000005),
MDSYS.SDO_DIM_ELEMENT('Z', -500000, 500000, 0.0000000005)
),
9989);

```

```

CREATE INDEX GIS_ELECTRICALSEGMENT_SIDX ON GIS_ELECTRICALSEGMENT(OGC_GEOMETRY)
INDEXTYPE IS MDSYS.SPATIAL_INDEX PARAMETERS('layer_gtype=curve');

```

```

DELETE FROM USER_SDO_GEOM_METADATA WHERE TABLE_NAME = 'GIS_ELEVATIONCONTOUR' AND
COLUMN_NAME = 'OGC_GEOMETRY';

```

```

INSERT INTO USER_SDO_GEOM_METADATA (TABLE_NAME, COLUMN_NAME, DIMINFO, SRID)
VALUES ('GIS_ELEVATIONCONTOUR', 'OGC_GEOMETRY',
MDSYS.SDO_DIM_ARRAY
(
MDSYS.SDO_DIM_ELEMENT('X', 0, 999999, 0.0000000005),
MDSYS.SDO_DIM_ELEMENT('Y', 0, 999999, 0.0000000005),
MDSYS.SDO_DIM_ELEMENT('Z', -500000, 500000, 0.0000000005)
),
9989);

```

```
CREATE INDEX GIS_ELEVATIONCONTOUR_SIDX ON GIS_ELEVATIONCONTOUR (OGC_GEOMETRY) INDEXTYPE
IS MDSYS.SPATIAL_INDEX PARAMETERS ('layer_gtype=curve');
```

```
DELETE FROM USER_SDO_GEOM_METADATA WHERE TABLE_NAME = 'GIS_EXTERNALPROPERTYINTEREST'
AND COLUMN_NAME = 'OGC_GEOMETRY';
```

```
INSERT INTO USER_SDO_GEOM_METADATA (TABLE_NAME, COLUMN_NAME, DIMINFO, SRID)
VALUES ('GIS_EXTERNALPROPERTYINTEREST', 'OGC_GEOMETRY',
MDSYS.SDO_DIM_ARRAY
(
MDSYS.SDO_DIM_ELEMENT('X', 0, 999999, 0.0000000005),
MDSYS.SDO_DIM_ELEMENT('Y', 0, 999999, 0.0000000005),
MDSYS.SDO_DIM_ELEMENT('Z', -500000, 500000, 0.0000000005)
),
9989);
```

```
CREATE INDEX GIS_EXTERNALPROPERTYINTER_SIDX ON
GIS_EXTERNALPROPERTYINTEREST (OGC_GEOMETRY) INDEXTYPE IS MDSYS.SPATIAL_INDEX
PARAMETERS ('layer_gtype=multipolygon');
```

```
DELETE FROM USER_SDO_GEOM_METADATA WHERE TABLE_NAME = 'GIS_FENCE' AND COLUMN_NAME =
'OGC_GEOMETRY';
```

```
INSERT INTO USER_SDO_GEOM_METADATA (TABLE_NAME, COLUMN_NAME, DIMINFO, SRID)
VALUES ('GIS_FENCE', 'OGC_GEOMETRY',
MDSYS.SDO_DIM_ARRAY
(
MDSYS.SDO_DIM_ELEMENT('X', 0, 999999, 0.0000000005),
MDSYS.SDO_DIM_ELEMENT('Y', 0, 999999, 0.0000000005),
MDSYS.SDO_DIM_ELEMENT('Z', -500000, 500000, 0.0000000005)
),
9989);
```

```
CREATE INDEX GIS_FENCE_SIDX ON GIS_FENCE (OGC_GEOMETRY) INDEXTYPE IS MDSYS.SPATIAL_INDEX
PARAMETERS ('layer_gtype=curve');
```

```
DELETE FROM USER_SDO_GEOM_METADATA WHERE TABLE_NAME = 'GIS_GASNODE' AND COLUMN_NAME =
'OGC_GEOMETRY';
```

```
INSERT INTO USER_SDO_GEOM_METADATA (TABLE_NAME, COLUMN_NAME, DIMINFO, SRID)
VALUES ('GIS_GASNODE', 'OGC_GEOMETRY',
MDSYS.SDO_DIM_ARRAY
(
MDSYS.SDO_DIM_ELEMENT('X', 0, 999999, 0.0000000005),
MDSYS.SDO_DIM_ELEMENT('Y', 0, 999999, 0.0000000005),
MDSYS.SDO_DIM_ELEMENT('Z', -500000, 500000, 0.0000000005)
),
9989);
```

```
CREATE INDEX GIS_GASNODE_SIDX ON GIS_GASNODE (OGC_GEOMETRY) INDEXTYPE IS
MDSYS.SPATIAL_INDEX PARAMETERS ('layer_gtype=point');
```

```
DELETE FROM USER_SDO_GEOM_METADATA WHERE TABLE_NAME = 'GIS_GASSEMENT' AND COLUMN_NAME
= 'OGC_GEOMETRY';
```

```
INSERT INTO USER_SDO_GEOM_METADATA (TABLE_NAME, COLUMN_NAME, DIMINFO, SRID)
VALUES ('GIS_GASSEMENT', 'OGC_GEOMETRY',
MDSYS.SDO_DIM_ARRAY
(
```

```

MDSYS.SDO_DIM_ELEMENT('X', 0, 999999, 0.0000000005),
MDSYS.SDO_DIM_ELEMENT('Y', 0, 999999, 0.0000000005),
MDSYS.SDO_DIM_ELEMENT('Z', -500000, 500000, 0.0000000005)
),
9989);

```

```

CREATE INDEX GIS_GASSEMENT_SIDX ON GIS_GASSEMENT(OGC_GEOMETRY) INDEXTYPE IS
MDSYS.SPATIAL_INDEX PARAMETERS('layer_gtype=curve');

```

```

DELETE FROM USER_SDO_GEOM_METADATA WHERE TABLE_NAME = 'GIS_GRID' AND COLUMN_NAME =
'OGC_GEOMETRY';

```

```

INSERT INTO USER_SDO_GEOM_METADATA (TABLE_NAME, COLUMN_NAME, DIMINFO, SRID)
VALUES ('GIS_GRID', 'OGC_GEOMETRY',
MDSYS.SDO_DIM_ARRAY
(
MDSYS.SDO_DIM_ELEMENT('X', 0, 999999, 0.0000000005),
MDSYS.SDO_DIM_ELEMENT('Y', 0, 999999, 0.0000000005),
MDSYS.SDO_DIM_ELEMENT('Z', -500000, 500000, 0.0000000005)
),
9989);

```

```

CREATE INDEX GIS_GRID_SIDX ON GIS_GRID(OGC_GEOMETRY) INDEXTYPE IS MDSYS.SPATIAL_INDEX
PARAMETERS('layer_gtype=multipolygon');

```

```

DELETE FROM USER_SDO_GEOM_METADATA WHERE TABLE_NAME = 'GIS_GUARDRAIL' AND COLUMN_NAME
= 'OGC_GEOMETRY';

```

```

INSERT INTO USER_SDO_GEOM_METADATA (TABLE_NAME, COLUMN_NAME, DIMINFO, SRID)
VALUES ('GIS_GUARDRAIL', 'OGC_GEOMETRY',
MDSYS.SDO_DIM_ARRAY
(
MDSYS.SDO_DIM_ELEMENT('X', 0, 999999, 0.0000000005),
MDSYS.SDO_DIM_ELEMENT('Y', 0, 999999, 0.0000000005),
MDSYS.SDO_DIM_ELEMENT('Z', -500000, 500000, 0.0000000005)
),
9989);

```

```

CREATE INDEX GIS_GUARDRAIL_SIDX ON GIS_GUARDRAIL(OGC_GEOMETRY) INDEXTYPE IS
MDSYS.SPATIAL_INDEX PARAMETERS('layer_gtype=curve');

```

```

DELETE FROM USER_SDO_GEOM_METADATA WHERE TABLE_NAME = 'GIS_INSTALLATION' AND
COLUMN_NAME = 'OGC_GEOMETRY';

```

```

INSERT INTO USER_SDO_GEOM_METADATA (TABLE_NAME, COLUMN_NAME, DIMINFO, SRID)
VALUES ('GIS_INSTALLATION', 'OGC_GEOMETRY',
MDSYS.SDO_DIM_ARRAY
(
MDSYS.SDO_DIM_ELEMENT('X', 0, 999999, 0.0000000005),
MDSYS.SDO_DIM_ELEMENT('Y', 0, 999999, 0.0000000005),
MDSYS.SDO_DIM_ELEMENT('Z', -500000, 500000, 0.0000000005)
),
9989);

```

```

CREATE INDEX GIS_INSTALLATION_SIDX ON GIS_INSTALLATION(OGC_GEOMETRY) INDEXTYPE IS
MDSYS.SPATIAL_INDEX PARAMETERS('layer_gtype=multipolygon');

```

```

DELETE FROM USER_SDO_GEOM_METADATA WHERE TABLE_NAME = 'GIS_LANDPARCEL' AND COLUMN_NAME
= 'OGC_GEOMETRY';

```



```

INSERT INTO USER_SDO_GEOM_METADATA (TABLE_NAME, COLUMN_NAME, DIMINFO, SRID)
VALUES ('GIS_LANDPARCEL', 'OGC_GEOMETRY',
MDSYS.SDO_DIM_ARRAY
(
MDSYS.SDO_DIM_ELEMENT('X', 0, 999999, 0.0000000005),
MDSYS.SDO_DIM_ELEMENT('Y', 0, 999999, 0.0000000005),
MDSYS.SDO_DIM_ELEMENT('Z', -500000, 500000, 0.0000000005)
),
9989);

```

```

CREATE INDEX GIS_LANDPARCEL_SIDX ON GIS_LANDPARCEL(OGC_GEOMETRY) INDEXTYPE IS
MDSYS.SPATIAL_INDEX PARAMETERS('layer_gtype=multipolygon');

```

```

DELETE FROM USER_SDO_GEOM_METADATA WHERE TABLE_NAME = 'GIS_PAVEMENTSECTION' AND
COLUMN_NAME = 'OGC_GEOMETRY';

```

```

INSERT INTO USER_SDO_GEOM_METADATA (TABLE_NAME, COLUMN_NAME, DIMINFO, SRID)
VALUES ('GIS_PAVEMENTSECTION', 'OGC_GEOMETRY',
MDSYS.SDO_DIM_ARRAY
(
MDSYS.SDO_DIM_ELEMENT('X', 0, 999999, 0.0000000005),
MDSYS.SDO_DIM_ELEMENT('Y', 0, 999999, 0.0000000005),
MDSYS.SDO_DIM_ELEMENT('Z', -500000, 500000, 0.0000000005)
),
9989);

```

```

CREATE INDEX GIS_PAVEMENTSECTION_SIDX ON GIS_PAVEMENTSECTION(OGC_GEOMETRY) INDEXTYPE
IS MDSYS.SPATIAL_INDEX PARAMETERS('layer_gtype=multipolygon');

```

```

DELETE FROM USER_SDO_GEOM_METADATA WHERE TABLE_NAME = 'GIS_POLNODE' AND COLUMN_NAME =
'OGC_GEOMETRY';

```

```

INSERT INTO USER_SDO_GEOM_METADATA (TABLE_NAME, COLUMN_NAME, DIMINFO, SRID)
VALUES ('GIS_POLNODE', 'OGC_GEOMETRY',
MDSYS.SDO_DIM_ARRAY
(
MDSYS.SDO_DIM_ELEMENT('X', 0, 999999, 0.0000000005),
MDSYS.SDO_DIM_ELEMENT('Y', 0, 999999, 0.0000000005),
MDSYS.SDO_DIM_ELEMENT('Z', -500000, 500000, 0.0000000005)
),
9989);

```

```

CREATE INDEX GIS_POLNODE_SIDX ON GIS_POLNODE(OGC_GEOMETRY) INDEXTYPE IS
MDSYS.SPATIAL_INDEX PARAMETERS('layer_gtype=point');

```

```

DELETE FROM USER_SDO_GEOM_METADATA WHERE TABLE_NAME = 'GIS_POLSEGMENT' AND COLUMN_NAME
= 'OGC_GEOMETRY';

```

```

INSERT INTO USER_SDO_GEOM_METADATA (TABLE_NAME, COLUMN_NAME, DIMINFO, SRID)
VALUES ('GIS_POLSEGMENT', 'OGC_GEOMETRY',
MDSYS.SDO_DIM_ARRAY
(
MDSYS.SDO_DIM_ELEMENT('X', 0, 999999, 0.0000000005),
MDSYS.SDO_DIM_ELEMENT('Y', 0, 999999, 0.0000000005),
MDSYS.SDO_DIM_ELEMENT('Z', -500000, 500000, 0.0000000005)
),
9989);

```

```
CREATE INDEX GIS_POLSEGMENT_SIDX ON GIS_POLSEGMENT(OGC_GEOMETRY) INDEXTYPE IS
MDSYS.SPATIAL_INDEX PARAMETERS('layer_gtype=curve');
```

```
DELETE FROM USER_SDO_GEOM_METADATA WHERE TABLE_NAME = 'GIS_PROJECTREFERENCE' AND
COLUMN_NAME = 'OGC_GEOMETRY';
```

```
INSERT INTO USER_SDO_GEOM_METADATA (TABLE_NAME, COLUMN_NAME, DIMINFO, SRID)
VALUES ('GIS_PROJECTREFERENCE', 'OGC_GEOMETRY',
MDSYS.SDO_DIM_ARRAY
(
MDSYS.SDO_DIM_ELEMENT('X', 0, 999999, 0.0000000005),
MDSYS.SDO_DIM_ELEMENT('Y', 0, 999999, 0.0000000005),
MDSYS.SDO_DIM_ELEMENT('Z', -500000, 500000, 0.0000000005)
),
9989);
```

```
CREATE INDEX GIS_PROJECTREFERENCE_SIDX ON GIS_PROJECTREFERENCE(OGC_GEOMETRY) INDEXTYPE IS
MDSYS.SPATIAL_INDEX PARAMETERS('layer_gtype=multipolygon');
```

```
DELETE FROM USER_SDO_GEOM_METADATA WHERE TABLE_NAME = 'GIS_RAILTRACK' AND COLUMN_NAME
= 'OGC_GEOMETRY';
```

```
INSERT INTO USER_SDO_GEOM_METADATA (TABLE_NAME, COLUMN_NAME, DIMINFO, SRID)
VALUES ('GIS_RAILTRACK', 'OGC_GEOMETRY',
MDSYS.SDO_DIM_ARRAY
(
MDSYS.SDO_DIM_ELEMENT('X', 0, 999999, 0.0000000005),
MDSYS.SDO_DIM_ELEMENT('Y', 0, 999999, 0.0000000005),
MDSYS.SDO_DIM_ELEMENT('Z', -500000, 500000, 0.0000000005)
),
9989);
```

```
CREATE INDEX GIS_RAILTRACK_SIDX ON GIS_RAILTRACK(OGC_GEOMETRY) INDEXTYPE IS
MDSYS.SPATIAL_INDEX PARAMETERS('layer_gtype=curve');
```

```
DELETE FROM USER_SDO_GEOM_METADATA WHERE TABLE_NAME = 'GIS_RECREATIONAREA' AND
COLUMN_NAME = 'OGC_GEOMETRY';
```

```
INSERT INTO USER_SDO_GEOM_METADATA (TABLE_NAME, COLUMN_NAME, DIMINFO, SRID)
VALUES ('GIS_RECREATIONAREA', 'OGC_GEOMETRY',
MDSYS.SDO_DIM_ARRAY
(
MDSYS.SDO_DIM_ELEMENT('X', 0, 999999, 0.0000000005),
MDSYS.SDO_DIM_ELEMENT('Y', 0, 999999, 0.0000000005),
MDSYS.SDO_DIM_ELEMENT('Z', -500000, 500000, 0.0000000005)
),
9989);
```

```
CREATE INDEX GIS_RECREATIONAREA_SIDX ON GIS_RECREATIONAREA(OGC_GEOMETRY) INDEXTYPE IS
MDSYS.SPATIAL_INDEX PARAMETERS('layer_gtype=multipolygon');
```

```
DELETE FROM USER_SDO_GEOM_METADATA WHERE TABLE_NAME = 'GIS_RECREATIONFEATURE' AND
COLUMN_NAME = 'OGC_GEOMETRY';
```

```
INSERT INTO USER_SDO_GEOM_METADATA (TABLE_NAME, COLUMN_NAME, DIMINFO, SRID)
VALUES ('GIS_RECREATIONFEATURE', 'OGC_GEOMETRY',
MDSYS.SDO_DIM_ARRAY
(
MDSYS.SDO_DIM_ELEMENT('X', 0, 999999, 0.0000000005),
MDSYS.SDO_DIM_ELEMENT('Y', 0, 999999, 0.0000000005),
MDSYS.SDO_DIM_ELEMENT('Z', -500000, 500000, 0.0000000005)
),
9989);
```

```

        MDSYS.SDO_DIM_ELEMENT('Z', -500000, 500000, 0.000000005)
    ),
    9989);

```

```

CREATE INDEX GIS_RECREATIONFEATURE_SIDX ON GIS_RECREATIONFEATURE(OGC_GEOMETRY)
INDEXTYPE IS MDSYS.SPATIAL_INDEX PARAMETERS('layer_gtype=point');

```

```

DELETE FROM USER_SDO_GEOM_METADATA WHERE TABLE_NAME = 'GIS_RESTRICTEDAREA' AND
COLUMN_NAME = 'OGC_GEOMETRY';

```

```

INSERT INTO USER_SDO_GEOM_METADATA (TABLE_NAME, COLUMN_NAME, DIMINFO, SRID)
VALUES ('GIS_RESTRICTEDAREA', 'OGC_GEOMETRY',
MDSYS.SDO_DIM_ARRAY
(
    MDSYS.SDO_DIM_ELEMENT('X', 0, 999999, 0.000000005),
    MDSYS.SDO_DIM_ELEMENT('Y', 0, 999999, 0.000000005),
    MDSYS.SDO_DIM_ELEMENT('Z', -500000, 500000, 0.000000005)
),
    9989);

```

```

CREATE INDEX GIS_RESTRICTEDAREA_SIDX ON GIS_RESTRICTEDAREA(OGC_GEOMETRY) INDEXTYPE IS
MDSYS.SPATIAL_INDEX PARAMETERS('layer_gtype=multipolygon');

```

```

DELETE FROM USER_SDO_GEOM_METADATA WHERE TABLE_NAME = 'GIS_ROADPATH' AND COLUMN_NAME
= 'OGC_GEOMETRY';

```

```

INSERT INTO USER_SDO_GEOM_METADATA (TABLE_NAME, COLUMN_NAME, DIMINFO, SRID)
VALUES ('GIS_ROADPATH', 'OGC_GEOMETRY',
MDSYS.SDO_DIM_ARRAY
(
    MDSYS.SDO_DIM_ELEMENT('X', 0, 999999, 0.000000005),
    MDSYS.SDO_DIM_ELEMENT('Y', 0, 999999, 0.000000005),
    MDSYS.SDO_DIM_ELEMENT('Z', -500000, 500000, 0.000000005)
),
    9989);

```

```

CREATE INDEX GIS_ROADPATH_SIDX ON GIS_ROADPATH(OGC_GEOMETRY) INDEXTYPE IS
MDSYS.SPATIAL_INDEX PARAMETERS('layer_gtype=curve');

```

```

DELETE FROM USER_SDO_GEOM_METADATA WHERE TABLE_NAME = 'GIS_SIGN' AND COLUMN_NAME =
'OGC_GEOMETRY';

```

```

INSERT INTO USER_SDO_GEOM_METADATA (TABLE_NAME, COLUMN_NAME, DIMINFO, SRID)
VALUES ('GIS_SIGN', 'OGC_GEOMETRY',
MDSYS.SDO_DIM_ARRAY
(
    MDSYS.SDO_DIM_ELEMENT('X', 0, 999999, 0.000000005),
    MDSYS.SDO_DIM_ELEMENT('Y', 0, 999999, 0.000000005),
    MDSYS.SDO_DIM_ELEMENT('Z', -500000, 500000, 0.000000005)
),
    9989);

```

```

CREATE INDEX GIS_SIGN_SIDX ON GIS_SIGN(OGC_GEOMETRY) INDEXTYPE IS MDSYS.SPATIAL_INDEX
PARAMETERS('layer_gtype=point');

```

```

DELETE FROM USER_SDO_GEOM_METADATA WHERE TABLE_NAME = 'GIS_SITE' AND COLUMN_NAME =
'OGC_GEOMETRY';

```

```

INSERT INTO USER_SDO_GEOM_METADATA (TABLE_NAME, COLUMN_NAME, DIMINFO, SRID)
VALUES ('GIS_SITE', 'OGC_GEOMETRY',

```

```

MDSYS.SDO_DIM_ARRAY
(
  MDSYS.SDO_DIM_ELEMENT('X', 0, 999999, 0.0000000005),
  MDSYS.SDO_DIM_ELEMENT('Y', 0, 999999, 0.0000000005),
  MDSYS.SDO_DIM_ELEMENT('Z', -500000, 500000, 0.0000000005)
),
9989);

```

```

CREATE INDEX GIS_SITE_SIDX ON GIS_SITE(OGC_GEOMETRY) INDEXTYPE IS MDSYS.SPATIAL_INDEX
PARAMETERS('layer_gtype=multipolygon');

```

```

DELETE FROM USER_SDO_GEOM_METADATA WHERE TABLE_NAME = 'GIS_STRUCTURE' AND COLUMN_NAME
= 'OGC_GEOMETRY';

```

```

INSERT INTO USER_SDO_GEOM_METADATA (TABLE_NAME, COLUMN_NAME, DIMINFO, SRID)
VALUES ('GIS_STRUCTURE', 'OGC_GEOMETRY',
MDSYS.SDO_DIM_ARRAY
(
  MDSYS.SDO_DIM_ELEMENT('X', 0, 999999, 0.0000000005),
  MDSYS.SDO_DIM_ELEMENT('Y', 0, 999999, 0.0000000005),
  MDSYS.SDO_DIM_ELEMENT('Z', -500000, 500000, 0.0000000005)
),
9989);

```

```

CREATE INDEX GIS_STRUCTURE_SIDX ON GIS_STRUCTURE(OGC_GEOMETRY) INDEXTYPE IS
MDSYS.SPATIAL_INDEX PARAMETERS('layer_gtype=multipolygon');

```

```

DELETE FROM USER_SDO_GEOM_METADATA WHERE TABLE_NAME = 'GIS_SURVEYJOB' AND COLUMN_NAME
= 'OGC_GEOMETRY';

```

```

INSERT INTO USER_SDO_GEOM_METADATA (TABLE_NAME, COLUMN_NAME, DIMINFO, SRID)
VALUES ('GIS_SURVEYJOB', 'OGC_GEOMETRY',
MDSYS.SDO_DIM_ARRAY
(
  MDSYS.SDO_DIM_ELEMENT('X', 0, 999999, 0.0000000005),
  MDSYS.SDO_DIM_ELEMENT('Y', 0, 999999, 0.0000000005),
  MDSYS.SDO_DIM_ELEMENT('Z', -500000, 500000, 0.0000000005)
),
9989);

```

```

CREATE INDEX GIS_SURVEYJOB_SIDX ON GIS_SURVEYJOB(OGC_GEOMETRY) INDEXTYPE IS
MDSYS.SPATIAL_INDEX PARAMETERS('layer_gtype=multipolygon');

```

```

DELETE FROM USER_SDO_GEOM_METADATA WHERE TABLE_NAME = 'GIS_SURVEYPOINT' AND COLUMN_NAME
= 'OGC_GEOMETRY';

```

```

INSERT INTO USER_SDO_GEOM_METADATA (TABLE_NAME, COLUMN_NAME, DIMINFO, SRID)
VALUES ('GIS_SURVEYPOINT', 'OGC_GEOMETRY',
MDSYS.SDO_DIM_ARRAY
(
  MDSYS.SDO_DIM_ELEMENT('X', 0, 999999, 0.0000000005),
  MDSYS.SDO_DIM_ELEMENT('Y', 0, 999999, 0.0000000005),
  MDSYS.SDO_DIM_ELEMENT('Z', -500000, 500000, 0.0000000005)
),
9989);

```

```

CREATE INDEX GIS_SURVEYPOINT_SIDX ON GIS_SURVEYPOINT(OGC_GEOMETRY) INDEXTYPE IS
MDSYS.SPATIAL_INDEX PARAMETERS('layer_gtype=point');

```

```

DELETE FROM USER_SDO_GEOM_METADATA WHERE TABLE_NAME = 'GIS_THERMALNODE' AND COLUMN_NAME
= 'OGC_GEOMETRY';
INSERT INTO USER_SDO_GEOM_METADATA (TABLE_NAME, COLUMN_NAME, DIMINFO, SRID)
VALUES ('GIS_THERMALNODE', 'OGC_GEOMETRY',
MDSYS.SDO_DIM_ARRAY
(
MDSYS.SDO_DIM_ELEMENT('X', 0, 999999, 0.0000000005),
MDSYS.SDO_DIM_ELEMENT('Y', 0, 999999, 0.0000000005),
MDSYS.SDO_DIM_ELEMENT('Z', -500000, 500000, 0.0000000005)
),
9989);

CREATE INDEX GIS_THERMALNODE_SIDX ON GIS_THERMALNODE(OGC_GEOMETRY) INDEXTYPE IS
MDSYS.SPATIAL_INDEX PARAMETERS('layer_gtype=point');

DELETE FROM USER_SDO_GEOM_METADATA WHERE TABLE_NAME = 'GIS_THERMALSEGMENT' AND
COLUMN_NAME = 'OGC_GEOMETRY';
INSERT INTO USER_SDO_GEOM_METADATA (TABLE_NAME, COLUMN_NAME, DIMINFO, SRID)
VALUES ('GIS_THERMALSEGMENT', 'OGC_GEOMETRY',
MDSYS.SDO_DIM_ARRAY
(
MDSYS.SDO_DIM_ELEMENT('X', 0, 999999, 0.0000000005),
MDSYS.SDO_DIM_ELEMENT('Y', 0, 999999, 0.0000000005),
MDSYS.SDO_DIM_ELEMENT('Z', -500000, 500000, 0.0000000005)
),
9989);

CREATE INDEX GIS_THERMALSEGMENT_SIDX ON GIS_THERMALSEGMENT(OGC_GEOMETRY) INDEXTYPE IS
MDSYS.SPATIAL_INDEX PARAMETERS('layer_gtype=curve');

DELETE FROM USER_SDO_GEOM_METADATA WHERE TABLE_NAME = 'GIS_TOWER' AND COLUMN_NAME =
'OGC_GEOMETRY';
INSERT INTO USER_SDO_GEOM_METADATA (TABLE_NAME, COLUMN_NAME, DIMINFO, SRID)
VALUES ('GIS_TOWER', 'OGC_GEOMETRY',
MDSYS.SDO_DIM_ARRAY
(
MDSYS.SDO_DIM_ELEMENT('X', 0, 999999, 0.0000000005),
MDSYS.SDO_DIM_ELEMENT('Y', 0, 999999, 0.0000000005),
MDSYS.SDO_DIM_ELEMENT('Z', -500000, 500000, 0.0000000005)
),
9989);

CREATE INDEX GIS_TOWER_SIDX ON GIS_TOWER(OGC_GEOMETRY) INDEXTYPE IS MDSYS.SPATIAL_INDEX
PARAMETERS('layer_gtype=point');

DELETE FROM USER_SDO_GEOM_METADATA WHERE TABLE_NAME = 'GIS_TRANSPORTATIONTUNNEL' AND
COLUMN_NAME = 'OGC_GEOMETRY';
INSERT INTO USER_SDO_GEOM_METADATA (TABLE_NAME, COLUMN_NAME, DIMINFO, SRID)
VALUES ('GIS_TRANSPORTATIONTUNNEL', 'OGC_GEOMETRY',
MDSYS.SDO_DIM_ARRAY
(
MDSYS.SDO_DIM_ELEMENT('X', 0, 999999, 0.0000000005),
MDSYS.SDO_DIM_ELEMENT('Y', 0, 999999, 0.0000000005),
MDSYS.SDO_DIM_ELEMENT('Z', -500000, 500000, 0.0000000005)
),
9989);

```

```
CREATE INDEX GIS_TRANSPORTATIONTUNNEL_SIDX ON GIS_TRANSPORTATIONTUNNEL(OGC_GEOMETRY)
INDEXTYPE IS MDSYS.SPATIAL_INDEX PARAMETERS('layer_gtype=multipolygon');
```

```
DELETE FROM USER_SDO_GEOM_METADATA WHERE TABLE_NAME = 'GIS_UTILITYFEATURE' AND
COLUMN_NAME = 'OGC_GEOMETRY';
```

```
INSERT INTO USER_SDO_GEOM_METADATA (TABLE_NAME, COLUMN_NAME, DIMINFO, SRID)
VALUES ('GIS_UTILITYFEATURE', 'OGC_GEOMETRY',
MDSYS.SDO_DIM_ARRAY
(
MDSYS.SDO_DIM_ELEMENT('X', 0, 999999, 0.0000000005),
MDSYS.SDO_DIM_ELEMENT('Y', 0, 999999, 0.0000000005),
MDSYS.SDO_DIM_ELEMENT('Z', -500000, 500000, 0.0000000005)
),
9989);
```

```
CREATE INDEX GIS_UTILITYFEATURE_SIDX ON GIS_UTILITYFEATURE(OGC_GEOMETRY) INDEXTYPE IS
MDSYS.SPATIAL_INDEX PARAMETERS('layer_gtype=multipolygon');
```

```
DELETE FROM USER_SDO_GEOM_METADATA WHERE TABLE_NAME = 'GIS_WALL' AND COLUMN_NAME =
'OGC_GEOMETRY';
```

```
INSERT INTO USER_SDO_GEOM_METADATA (TABLE_NAME, COLUMN_NAME, DIMINFO, SRID)
VALUES ('GIS_WALL', 'OGC_GEOMETRY',
MDSYS.SDO_DIM_ARRAY
(
MDSYS.SDO_DIM_ELEMENT('X', 0, 999999, 0.0000000005),
MDSYS.SDO_DIM_ELEMENT('Y', 0, 999999, 0.0000000005),
MDSYS.SDO_DIM_ELEMENT('Z', -500000, 500000, 0.0000000005)
),
9989);
```

```
CREATE INDEX GIS_WALL_SIDX ON GIS_WALL(OGC_GEOMETRY) INDEXTYPE IS MDSYS.SPATIAL_INDEX
PARAMETERS('layer_gtype=curve');
```

```
DELETE FROM USER_SDO_GEOM_METADATA WHERE TABLE_NAME = 'GIS_WASTEWATERNODE' AND
COLUMN_NAME = 'OGC_GEOMETRY';
```

```
INSERT INTO USER_SDO_GEOM_METADATA (TABLE_NAME, COLUMN_NAME, DIMINFO, SRID)
VALUES ('GIS_WASTEWATERNODE', 'OGC_GEOMETRY',
MDSYS.SDO_DIM_ARRAY
(
MDSYS.SDO_DIM_ELEMENT('X', 0, 999999, 0.0000000005),
MDSYS.SDO_DIM_ELEMENT('Y', 0, 999999, 0.0000000005),
MDSYS.SDO_DIM_ELEMENT('Z', -500000, 500000, 0.0000000005)
),
9989);
```

```
CREATE INDEX GIS_WASTEWATERNODE_SIDX ON GIS_WASTEWATERNODE(OGC_GEOMETRY) INDEXTYPE IS
MDSYS.SPATIAL_INDEX PARAMETERS('layer_gtype=point');
```

```
DELETE FROM USER_SDO_GEOM_METADATA WHERE TABLE_NAME = 'GIS_WASTEWATERSEGMENT' AND
COLUMN_NAME = 'OGC_GEOMETRY';
```

```
INSERT INTO USER_SDO_GEOM_METADATA (TABLE_NAME, COLUMN_NAME, DIMINFO, SRID)
VALUES ('GIS_WASTEWATERSEGMENT', 'OGC_GEOMETRY',
MDSYS.SDO_DIM_ARRAY
(
MDSYS.SDO_DIM_ELEMENT('X', 0, 999999, 0.0000000005),
```

```

MDSYS.SDO_DIM_ELEMENT('Y', 0, 999999, 0.0000000005),
MDSYS.SDO_DIM_ELEMENT('Z', -500000, 500000, 0.0000000005)
),
9989);

```

```

CREATE INDEX GIS_WASTEWATERSEGMENT_SIDX ON GIS_WASTEWATERSEGMENT(OGC_GEOMETRY)
INDEXTYPE IS MDSYS.SPATIAL_INDEX PARAMETERS('layer_gtype=curve');

```

```

DELETE FROM USER_SDO_GEOM_METADATA WHERE TABLE_NAME = 'GIS_WATERCOURSELINE' AND
COLUMN_NAME = 'OGC_GEOMETRY';

```

```

INSERT INTO USER_SDO_GEOM_METADATA (TABLE_NAME, COLUMN_NAME, DIMINFO, SRID)
VALUES ('GIS_WATERCOURSELINE', 'OGC_GEOMETRY',
MDSYS.SDO_DIM_ARRAY
(
MDSYS.SDO_DIM_ELEMENT('X', 0, 999999, 0.0000000005),
MDSYS.SDO_DIM_ELEMENT('Y', 0, 999999, 0.0000000005),
MDSYS.SDO_DIM_ELEMENT('Z', -500000, 500000, 0.0000000005)
),
9989);

```

```

CREATE INDEX GIS_WATERCOURSELINE_SIDX ON GIS_WATERCOURSELINE(OGC_GEOMETRY) INDEXTYPE
IS MDSYS.SPATIAL_INDEX PARAMETERS('layer_gtype=curve');

```

```

DELETE FROM USER_SDO_GEOM_METADATA WHERE TABLE_NAME = 'GIS_WATERFEATURE' AND
COLUMN_NAME = 'OGC_GEOMETRY';

```

```

INSERT INTO USER_SDO_GEOM_METADATA (TABLE_NAME, COLUMN_NAME, DIMINFO, SRID)
VALUES ('GIS_WATERFEATURE', 'OGC_GEOMETRY',
MDSYS.SDO_DIM_ARRAY
(
MDSYS.SDO_DIM_ELEMENT('X', 0, 999999, 0.0000000005),
MDSYS.SDO_DIM_ELEMENT('Y', 0, 999999, 0.0000000005),
MDSYS.SDO_DIM_ELEMENT('Z', -500000, 500000, 0.0000000005)
),
9989);

```

```

CREATE INDEX GIS_WATERFEATURE_SIDX ON GIS_WATERFEATURE(OGC_GEOMETRY) INDEXTYPE IS
MDSYS.SPATIAL_INDEX PARAMETERS('layer_gtype=multipolygon');

```

```

DELETE FROM USER_SDO_GEOM_METADATA WHERE TABLE_NAME = 'GIS_WATERNODE' AND COLUMN_NAME
= 'OGC_GEOMETRY';

```

```

INSERT INTO USER_SDO_GEOM_METADATA (TABLE_NAME, COLUMN_NAME, DIMINFO, SRID)
VALUES ('GIS_WATERNODE', 'OGC_GEOMETRY',
MDSYS.SDO_DIM_ARRAY
(
MDSYS.SDO_DIM_ELEMENT('X', 0, 999999, 0.0000000005),
MDSYS.SDO_DIM_ELEMENT('Y', 0, 999999, 0.0000000005),
MDSYS.SDO_DIM_ELEMENT('Z', -500000, 500000, 0.0000000005)
),
9989);

```

```

CREATE INDEX GIS_WATERNODE_SIDX ON GIS_WATERNODE(OGC_GEOMETRY) INDEXTYPE IS
MDSYS.SPATIAL_INDEX PARAMETERS('layer_gtype=point');

```

```

DELETE FROM USER_SDO_GEOM_METADATA WHERE TABLE_NAME = 'GIS_WATERSEGMENT' AND
COLUMN_NAME = 'OGC_GEOMETRY';

```

```

INSERT INTO USER_SDO_GEOM_METADATA (TABLE_NAME, COLUMN_NAME, DIMINFO, SRID)

```

```
VALUES ('GIS_WATERSEGMENT', 'OGC_GEOMETRY',
MDSYS.SDO_DIM_ARRAY
(
MDSYS.SDO_DIM_ELEMENT('X', 0, 999999, 0.0000000005),
MDSYS.SDO_DIM_ELEMENT('Y', 0, 999999, 0.0000000005),
MDSYS.SDO_DIM_ELEMENT('Z', -500000, 500000, 0.0000000005)
),
9989);
```

```
CREATE INDEX GIS_WATERSEGMENT_SIDX ON GIS_WATERSEGMENT(OGC_GEOMETRY) INDEXTYPE IS
MDSYS.SPATIAL_INDEX PARAMETERS('layer_gtype=curve');
```

```
-----
-- Sequences and Triggers
-----
```

```
-----
-- Sequence and Trigger BRIDGE_TR
-----
```

```
CREATE SEQUENCE "GIS"."BRIDGE_ID" MINVALUE 1 INCREMENT BY 1 START WITH 1 CACHE 20
NOORDER NOCYCLE;
CREATE OR REPLACE TRIGGER "GIS"."BRIDGE_TR"
before insert on BRIDGE
for each row
begin
select BRIDGE_ID.nextval
into :NEW.OBJECTID
from dual;
end;
/
ALTER TRIGGER "GIS"."BRIDGE_TR" ENABLE;
```

```
-----
-- Sequence and Trigger BUILDING_TR
-----
```

```
CREATE SEQUENCE "GIS"."BUILDING_ID" MINVALUE 1 INCREMENT BY 1 START WITH 21 CACHE
20 NOORDER NOCYCLE;
CREATE OR REPLACE TRIGGER "GIS"."BUILDING_TR"
before insert on BUILDING
for each row
begin
select BUILDING_ID.nextval
into :NEW.OBJECTID
from dual;
end;
/
ALTER TRIGGER "GIS"."BUILDING_TR" ENABLE;
```

```
-----
-- Sequence and Trigger COMMUNICATIONNODE_TR
-----
```

```
CREATE SEQUENCE "GIS"."COMMUNICATIONNODE_ID" MINVALUE 1 INCREMENT BY 1 START WITH
601 CACHE 20 NOORDER NOCYCLE;
CREATE OR REPLACE TRIGGER "GIS"."COMMUNICATIONNODE_TR"
before insert on COMMUNICATIONNODE
for each row
begin
select COMMUNICATIONNODE_ID.nextval
into :NEW.OBJECTID
```



```

    from dual;
end;
/
ALTER TRIGGER "GIS"."COMMUNICATIONNODE_TR" ENABLE;
-----
-- Sequence and Trigger COMMUNICATIONSEGMENT_TR
-----
CREATE SEQUENCE "GIS"."COMMUNICATIONSEGMENT_ID" MINVALUE 1 INCREMENT BY 1 START WITH
301 CACHE 20 NOORDER NOCYCLE;
CREATE OR REPLACE TRIGGER "GIS"."COMMUNICATIONSEGMENT_TR"
before insert on COMMUNICATIONSEGMENT
for each row
begin
    select COMMUNICATIONSEGMENT_ID.nextval
    into :NEW.OBJECTID
    from dual;
end;
/
ALTER TRIGGER "GIS"."COMMUNICATIONSEGMENT_TR" ENABLE;
-----
-- Sequence and Trigger CONFLICTNODE_TR
-----
CREATE SEQUENCE "GIS"."CONFLICTNODE_ID" MINVALUE 1 INCREMENT BY 1 START WITH 1 CACHE
20 NOORDER NOCYCLE;
CREATE OR REPLACE TRIGGER "GIS"."CONFLICTNODE_TR"
before insert on CONFLICTNODE
for each row
begin
    select CONFLICTNODE_ID.nextval
    into :NEW.OBJECTID
    from dual;
end;
/
ALTER TRIGGER "GIS"."CONFLICTNODE_TR" ENABLE;
-----
-- Sequence and Trigger CONSTRUCTIONLINE_TR
-----
CREATE SEQUENCE "GIS"."CONSTRUCTIONLINE_ID" MINVALUE 1 INCREMENT BY 1 START WITH
1 CACHE 20 NOORDER NOCYCLE;
CREATE OR REPLACE TRIGGER "GIS"."CONSTRUCTIONLINE_TR"
before insert on CONSTRUCTIONLINE
for each row
begin
    select CONSTRUCTIONLINE_ID.nextval
    into :NEW.OBJECTID
    from dual;
end;
/
ALTER TRIGGER "GIS"."CONSTRUCTIONLINE_TR" ENABLE;
-----
-- Sequence and Trigger CONTROLMONUMENTPOINT_TR
-----
CREATE SEQUENCE "GIS"."CONTROLMONUMENTPOINT_ID" MINVALUE 1 INCREMENT BY 1 START WITH
1 CACHE 20 NOORDER NOCYCLE;
CREATE OR REPLACE TRIGGER "GIS"."CONTROLMONUMENTPOINT_TR"
before insert on CONTROLMONUMENTPOINT

```

```

    for each row
begin
    select CONTROLMONUMENTPOINT_ID.nextval
    into :NEW.OBJECTID
    from dual;
end;
/
ALTER TRIGGER "GIS"."CONTROLMONUMENTPOINT_TR" ENABLE;
-----
-- Sequence and Trigger DOTPERMIT_TR
-----
CREATE SEQUENCE "GIS"."DOTPERMIT_ID" MINVALUE 1 INCREMENT BY 1 START WITH 41 CACHE
20 NOORDER NOCYCLE;
CREATE OR REPLACE TRIGGER "GIS"."DOTPERMIT_TR"
before insert on DOTPERMIT
for each row
begin
    select DOTPERMIT_ID.nextval
    into :NEW.OBJECTID
    from dual;
end;
/
ALTER TRIGGER "GIS"."DOTPERMIT_TR" ENABLE;
-----
-- Sequence and Trigger ELECCONDUITBANKSEGMENT_TR
-----
CREATE SEQUENCE "GIS"."ELECCONDUITBANKSEGMENT_ID" MINVALUE 1 INCREMENT BY 1 START
WITH 1 CACHE 20 NOORDER NOCYCLE;
CREATE OR REPLACE TRIGGER "GIS"."ELECCONDUITBANKSEGMENT_TR"
before insert on ELECCONDUITBANKSEGMENT
for each row
begin
    select ELECCONDUITBANKSEGMENT_ID.nextval
    into :NEW.OBJECTID
    from dual;
end;
/
ALTER TRIGGER "GIS"."ELECCONDUITBANKSEGMENT_TR" ENABLE;
-----
-- Sequence and Trigger ELECTRICALNODE_TR
-----
CREATE SEQUENCE "GIS"."ELECTRICALNODE_ID" MINVALUE 1 INCREMENT BY 1 START WITH 101
CACHE 20 NOORDER NOCYCLE;
CREATE OR REPLACE TRIGGER "GIS"."ELECTRICALNODE_TR"
before insert on ELECTRICALNODE
for each row
begin
    select ELECTRICALNODE_ID.nextval
    into :NEW.OBJECTID
    from dual;
end;
/
ALTER TRIGGER "GIS"."ELECTRICALNODE_TR" ENABLE;
-----
-- Sequence and Trigger ELECTRICALSEGMENT_TR
-----

```

```

CREATE SEQUENCE "GIS"."ELECTRICALSEGMENT_ID" MINVALUE 1 INCREMENT BY 1 START WITH
61 CACHE 20 NOORDER NOCYCLE;
CREATE OR REPLACE TRIGGER "GIS"."ELECTRICALSEGMENT_TR"
before insert on ELECTRICALSEGMENT
for each row
begin
select ELECTRICALSEGMENT_ID.nextval
into :NEW.OBJECTID
from dual;
end;
/
ALTER TRIGGER "GIS"."ELECTRICALSEGMENT_TR" ENABLE;
-----
-- Sequence and Trigger ELEVATIONCONTOUR_TR
-----
CREATE SEQUENCE "GIS"."ELEVATIONCONTOUR_ID" MINVALUE 1 INCREMENT BY 1 START WITH
1 CACHE 20 NOORDER NOCYCLE;
CREATE OR REPLACE TRIGGER "GIS"."ELEVATIONCONTOUR_TR"
before insert on ELEVATIONCONTOUR
for each row
begin
select ELEVATIONCONTOUR_ID.nextval
into :NEW.OBJECTID
from dual;
end;
/
ALTER TRIGGER "GIS"."ELEVATIONCONTOUR_TR" ENABLE;
-----
-- Sequence and Trigger EXTERNALPROPERTYINTEREST_TR
-----
CREATE SEQUENCE "GIS"."EXTERNALPROPERTYINTEREST_ID" MINVALUE 1 INCREMENT BY 1 START
WITH 1 CACHE 20 NOORDER NOCYCLE;
CREATE OR REPLACE TRIGGER "GIS"."EXTERNALPROPERTYINTEREST_TR"
before insert on EXTERNALPROPERTYINTEREST
for each row
begin
select EXTERNALPROPERTYINTEREST_ID.nextval
into :NEW.OBJECTID
from dual;
end;
/
ALTER TRIGGER "GIS"."EXTERNALPROPERTYINTEREST_TR" ENABLE;
-----
-- Sequence and Trigger FENCE_TR
-----
CREATE SEQUENCE "GIS"."FENCE_ID" MINVALUE 1 INCREMENT BY 1 START WITH 21 CACHE 20
NOORDER NOCYCLE;
CREATE OR REPLACE TRIGGER "GIS"."FENCE_TR"
before insert on FENCE
for each row
begin
select FENCE_ID.nextval
into :NEW.OBJECTID
from dual;
end;
/

```

```
ALTER TRIGGER "GIS"."FENCE_TR" ENABLE;
```

```
-----
-- Sequence and Trigger GASNODE_TR
-----
```

```
CREATE SEQUENCE "GIS"."GASNODE_ID" MINVALUE 1 INCREMENT BY 1 START WITH 161 CACHE
20 NOORDER NOCYCLE;
```

```
CREATE OR REPLACE TRIGGER "GIS"."GASNODE_TR"
before insert on GASNODE
for each row
```

```
begin
select GASNODE_ID.nextval
into :NEW.OBJECTID
from dual;
```

```
end;
```

```
/
```

```
ALTER TRIGGER "GIS"."GASNODE_TR" ENABLE;
```

```
-----
-- Sequence and Trigger GASSEGMENT_TR
-----
```

```
CREATE SEQUENCE "GIS"."GASSEGMENT_ID" MINVALUE 1 INCREMENT BY 1 START WITH 161 CACHE
20 NOORDER NOCYCLE;
```

```
CREATE OR REPLACE TRIGGER "GIS"."GASSEGMENT_TR"
before insert on GASSEGMENT
for each row
```

```
begin
select GASSEGMENT_ID.nextval
into :NEW.OBJECTID
from dual;
```

```
end;
```

```
/
```

```
ALTER TRIGGER "GIS"."GASSEGMENT_TR" ENABLE;
```

```
-----
-- Sequence and Trigger GRID_TR
-----
```

```
CREATE SEQUENCE "GIS"."GRID_ID" MINVALUE 1 INCREMENT BY 1 START WITH 1 CACHE 20 NOORDER
NOCYCLE;
```

```
CREATE OR REPLACE TRIGGER "GIS"."GRID_TR"
before insert on GRID
for each row
```

```
begin
select GRID_ID.nextval
into :NEW.OBJECTID
from dual;
```

```
end;
```

```
/
```

```
ALTER TRIGGER "GIS"."GRID_TR" ENABLE;
```

```
-----
-- Sequence and Trigger GUARDRAIL_TR
-----
```

```
CREATE SEQUENCE "GIS"."GUARDRAIL_ID" MINVALUE 1 INCREMENT BY 1 START WITH 1 CACHE
20 NOORDER NOCYCLE;
```

```
CREATE OR REPLACE TRIGGER "GIS"."GUARDRAIL_TR"
before insert on GUARDRAIL
for each row
```

```
begin
select GUARDRAIL_ID.nextval
```

```

    into :NEW.OBJECTID
    from dual;
end;
/
ALTER TRIGGER "GIS"."GUARDRAIL_TR" ENABLE;
-----
-- Sequence and Trigger INSTALLATION_TR
-----
CREATE SEQUENCE "GIS"."INSTALLATION_ID" MINVALUE 1 INCREMENT BY 1 START WITH 1 CACHE
20 NOORDER NOCYCLE;
CREATE OR REPLACE TRIGGER "GIS"."INSTALLATION_TR"
before insert on INSTALLATION
for each row
begin
    select INSTALLATION_ID.nextval
    into :NEW.OBJECTID
    from dual;
end;
/
ALTER TRIGGER "GIS"."INSTALLATION_TR" ENABLE;
-----
-- Sequence and Trigger LANDPARCEL_TR
-----
CREATE SEQUENCE "GIS"."LANDPARCEL_ID" MINVALUE 1 INCREMENT BY 1 START WITH 1 CACHE
20 NOORDER NOCYCLE;
CREATE OR REPLACE TRIGGER "GIS"."LANDPARCEL_TR"
before insert on LANDPARCEL
for each row
begin
    select LANDPARCEL_ID.nextval
    into :NEW.OBJECTID
    from dual;
end;
/
ALTER TRIGGER "GIS"."LANDPARCEL_TR" ENABLE;
-----
-- Sequence and Trigger PAVEMENTSECTION_TR
-----
CREATE SEQUENCE "GIS"."PAVEMENTSECTION_ID" MINVALUE 1 INCREMENT BY 1 START WITH 1
CACHE 20 NOORDER NOCYCLE;
CREATE OR REPLACE TRIGGER "GIS"."PAVEMENTSECTION_TR"
before insert on PAVEMENTSECTION
for each row
begin
    select PAVEMENTSECTION_ID.nextval
    into :NEW.OBJECTID
    from dual;
end;
/
ALTER TRIGGER "GIS"."PAVEMENTSECTION_TR" ENABLE;
-----
-- Sequence and Trigger POLNODE_TR
-----
CREATE SEQUENCE "GIS"."POLNODE_ID" MINVALUE 1 INCREMENT BY 1 START WITH 101 CACHE
20 NOORDER NOCYCLE;
CREATE OR REPLACE TRIGGER "GIS"."POLNODE_TR"

```

```

before insert on POLNODE
for each row
begin
select POLNODE_ID.nextval
into :NEW.OBJECTID
from dual;
end;
/
ALTER TRIGGER "GIS"."POLNODE_TR" ENABLE;
-----

-- Sequence and Trigger POLSEGMENT_TR
-----

CREATE SEQUENCE "GIS"."POLSEGMENT_ID" MINVALUE 1 INCREMENT BY 1 START WITH 61 CACHE
20 NOORDER NOCYCLE;
CREATE OR REPLACE TRIGGER "GIS"."POLSEGMENT_TR"
before insert on POLSEGMENT
for each row
begin
select POLSEGMENT_ID.nextval
into :NEW.OBJECTID
from dual;
end;
/
ALTER TRIGGER "GIS"."POLSEGMENT_TR" ENABLE;
-----

-- Sequence and Trigger PROJECTREFERENCE_TR
-----

CREATE SEQUENCE "GIS"."PROJECTREFERENCE_ID" MINVALUE 1 INCREMENT BY 1 START WITH
1 CACHE 20 NOORDER NOCYCLE;
CREATE OR REPLACE TRIGGER "GIS"."PROJECTREFERENCE_TR"
before insert on PROJECTREFERENCE
for each row
begin
select PROJECTREFERENCE_ID.nextval
into :NEW.OBJECTID
from dual;
end;
/
ALTER TRIGGER "GIS"."PROJECTREFERENCE_TR" ENABLE;
-----

-- Sequence and Trigger RAILTRACK_TR
-----

CREATE SEQUENCE "GIS"."RAILTRACK_ID" MINVALUE 1 INCREMENT BY 1 START WITH 1 CACHE
20 NOORDER NOCYCLE;
CREATE OR REPLACE TRIGGER "GIS"."RAILTRACK_TR"
before insert on RAILTRACK
for each row
begin
select RAILTRACK_ID.nextval
into :NEW.OBJECTID
from dual;
end;
/
ALTER TRIGGER "GIS"."RAILTRACK_TR" ENABLE;
-----

-- Sequence and Trigger RECREATIONAREA_TR

```

```

-----
CREATE SEQUENCE "GIS"."RECREATIONAREA_ID" MINVALUE 1 INCREMENT BY 1 START WITH 1
CACHE 20 NOORDER NOCYCLE;
CREATE OR REPLACE TRIGGER "GIS"."RECREATIONAREA_TR"
before insert on RECREATIONAREA
for each row
begin
select RECREATIONAREA_ID.nextval
into :NEW.OBJECTID
from dual;
end;
/
ALTER TRIGGER "GIS"."RECREATIONAREA_TR" ENABLE;
-----
-- Sequence and Trigger RECREATIONFEATURE_TR
-----
CREATE SEQUENCE "GIS"."RECREATIONFEATURE_ID" MINVALUE 1 INCREMENT BY 1 START WITH
1 CACHE 20 NOORDER NOCYCLE;
CREATE OR REPLACE TRIGGER "GIS"."RECREATIONFEATURE_TR"
before insert on RECREATIONFEATURE
for each row
begin
select RECREATIONFEATURE_ID.nextval
into :NEW.OBJECTID
from dual;
end;
/
ALTER TRIGGER "GIS"."RECREATIONFEATURE_TR" ENABLE;
-----
-- Sequence and Trigger RESTRICTEDAREA_TR
-----
CREATE SEQUENCE "GIS"."RESTRICTEDAREA_ID" MINVALUE 1 INCREMENT BY 1 START WITH 1
CACHE 20 NOORDER NOCYCLE;
CREATE OR REPLACE TRIGGER "GIS"."RESTRICTEDAREA_TR"
before insert on RESTRICTEDAREA
for each row
begin
select RESTRICTEDAREA_ID.nextval
into :NEW.OBJECTID
from dual;
end;
/
ALTER TRIGGER "GIS"."RESTRICTEDAREA_TR" ENABLE;
-----
-- Sequence and Trigger ROADPATH_TR
-----
CREATE SEQUENCE "GIS"."ROADPATH_ID" MINVALUE 1 INCREMENT BY 1 START WITH 1 CACHE
20 NOORDER NOCYCLE;
CREATE OR REPLACE TRIGGER "GIS"."ROADPATH_TR"
before insert on ROADPATH
for each row
begin
select ROADPATH_ID.nextval
into :NEW.OBJECTID
from dual;
end;

```

```

/
ALTER TRIGGER "GIS"."ROADPATH_TR" ENABLE;
-----
-- Sequence and Trigger SIGN_TR
-----
CREATE SEQUENCE "GIS"."SIGN_ID" MINVALUE 1 INCREMENT BY 1 START WITH 1 CACHE 20 NOORDER
NOCYCLE;
CREATE OR REPLACE TRIGGER "GIS"."SIGN_TR"
before insert on SIGN
for each row
begin
select SIGN_ID.nextval
into :NEW.OBJECTID
from dual;
end;
/
ALTER TRIGGER "GIS"."SIGN_TR" ENABLE;
-----
-- Sequence and Trigger SITE_TR
-----
CREATE SEQUENCE "GIS"."SITE_ID" MINVALUE 1 INCREMENT BY 1 START WITH 1 CACHE 20 NOORDER
NOCYCLE;
CREATE OR REPLACE TRIGGER "GIS"."SITE_TR"
before insert on SITE
for each row
begin
select SITE_ID.nextval
into :NEW.OBJECTID
from dual;
end;
/
ALTER TRIGGER "GIS"."SITE_TR" ENABLE;
-----
-- Sequence and Trigger STRUCTURE_TR
-----
CREATE SEQUENCE "GIS"."STRUCTURE_ID" MINVALUE 1 INCREMENT BY 1 START WITH 1 CACHE
20 NOORDER NOCYCLE;
CREATE OR REPLACE TRIGGER "GIS"."STRUCTURE_TR"
before insert on STRUCTURE
for each row
begin
select STRUCTURE_ID.nextval
into :NEW.OBJECTID
from dual;
end;
/
ALTER TRIGGER "GIS"."STRUCTURE_TR" ENABLE;
-----
-- Sequence and Trigger SURVEYJOB_TR
-----
CREATE SEQUENCE "GIS"."SURVEYJOB_ID" MINVALUE 1 INCREMENT BY 1 START WITH 1 CACHE
20 NOORDER NOCYCLE;
CREATE OR REPLACE TRIGGER "GIS"."SURVEYJOB_TR"
before insert on SURVEYJOB
for each row
begin

```



```

    select SURVEYJOB_ID.nextval
    into :NEW.OBJECTID
    from dual;
end;
/
ALTER TRIGGER "GIS"."SURVEYJOB_TR" ENABLE;
-----
-- Sequence and Trigger SURVEYPOINT_TR
-----
CREATE SEQUENCE "GIS"."SURVEYPOINT_ID" MINVALUE 1 INCREMENT BY 1 START WITH 1 CACHE
20 NOORDER NOCYCLE;
CREATE OR REPLACE TRIGGER "GIS"."SURVEYPOINT_TR"
before insert on SURVEYPOINT
for each row
begin
    select SURVEYPOINT_ID.nextval
    into :NEW.OBJECTID
    from dual;
end;
/
ALTER TRIGGER "GIS"."SURVEYPOINT_TR" ENABLE;
-----
-- Sequence and Trigger THERMALNODE_TR
-----
CREATE SEQUENCE "GIS"."THERMALNODE_ID" MINVALUE 1 INCREMENT BY 1 START WITH 21 CACHE
20 NOORDER NOCYCLE;
CREATE OR REPLACE TRIGGER "GIS"."THERMALNODE_TR"
before insert on THERMALNODE
for each row
begin
    select THERMALNODE_ID.nextval
    into :NEW.OBJECTID
    from dual;
end;
/
ALTER TRIGGER "GIS"."THERMALNODE_TR" ENABLE;
-----
-- Sequence and Trigger THERMALSEGMENT_TR
-----
CREATE SEQUENCE "GIS"."THERMALSEGMENT_ID" MINVALUE 1 INCREMENT BY 1 START WITH 21
CACHE 20 NOORDER NOCYCLE;
CREATE OR REPLACE TRIGGER "GIS"."THERMALSEGMENT_TR"
before insert on THERMALSEGMENT
for each row
begin
    select THERMALSEGMENT_ID.nextval
    into :NEW.OBJECTID
    from dual;
end;
/
ALTER TRIGGER "GIS"."THERMALSEGMENT_TR" ENABLE;
-----
-- Sequence and Trigger TOWER_TR
-----
CREATE SEQUENCE "GIS"."TOWER_ID" MINVALUE 1 INCREMENT BY 1 START WITH 1 CACHE 20
NOORDER NOCYCLE;

```

```

CREATE OR REPLACE TRIGGER "GIS"."TOWER_TR"
before insert on TOWER
for each row
begin
select TOWER_ID.nextval
into :NEW.OBJECTID
from dual;
end;
/
ALTER TRIGGER "GIS"."TOWER_TR" ENABLE;
-----
-- Sequence and Trigger TRANSPORTATIONTUNNEL_TR
-----
CREATE SEQUENCE "GIS"."TRANSPORTATIONTUNNEL_ID" MINVALUE 1 INCREMENT BY 1 START WITH
1 CACHE 20 NOORDER NOCYCLE;
CREATE OR REPLACE TRIGGER "GIS"."TRANSPORTATIONTUNNEL_TR"
before insert on TRANSPORTATIONTUNNEL
for each row
begin
select TRANSPORTATIONTUNNEL_ID.nextval
into :NEW.OBJECTID
from dual;
end;
/
ALTER TRIGGER "GIS"."TRANSPORTATIONTUNNEL_TR" ENABLE;
-----
-- Sequence and Trigger UTILITYFEATURE_TR
-----
CREATE SEQUENCE "GIS"."UTILITYFEATURE_ID" MINVALUE 1 INCREMENT BY 1 START WITH 1
CACHE 20 NOORDER NOCYCLE;
CREATE OR REPLACE TRIGGER "GIS"."UTILITYFEATURE_TR"
before insert on UTILITYFEATURE
for each row
begin
select UTILITYFEATURE_ID.nextval
into :NEW.OBJECTID
from dual;
end;
/
ALTER TRIGGER "GIS"."UTILITYFEATURE_TR" ENABLE;
-----
-- Sequence and Trigger WALL_TR
-----
CREATE SEQUENCE "GIS"."WALL_ID" MINVALUE 1 INCREMENT BY 1 START WITH 1 CACHE 20 NOORDER
NOCYCLE;
CREATE OR REPLACE TRIGGER "GIS"."WALL_TR"
before insert on WALL
for each row
begin
select WALL_ID.nextval
into :NEW.OBJECTID
from dual;
end;
/
ALTER TRIGGER "GIS"."WALL_TR" ENABLE;
-----

```

```

-- Sequence and Trigger WASTEWATERNODE_TR
-----
CREATE SEQUENCE "GIS"."WASTEWATERNODE_ID" MINVALUE 1 INCREMENT BY 1 START WITH 621
CACHE 20 NOORDER NOCYCLE;
CREATE OR REPLACE TRIGGER "GIS"."WASTEWATERNODE_TR"
before insert on WASTEWATERNODE
for each row
begin
select WASTEWATERNODE_ID.nextval
into :NEW.OBJECTID
from dual;
end;
/
ALTER TRIGGER "GIS"."WASTEWATERNODE_TR" ENABLE;
-----

-- Sequence and Trigger WASTEWATERSEGMENT_TR
-----
CREATE SEQUENCE "GIS"."WASTEWATERSEGMENT_ID" MINVALUE 1 INCREMENT BY 1 START WITH
401 CACHE 20 NOORDER NOCYCLE;
CREATE OR REPLACE TRIGGER "GIS"."WASTEWATERSEGMENT_TR"
before insert on WASTEWATERSEGMENT
for each row
begin
select WASTEWATERSEGMENT_ID.nextval
into :NEW.OBJECTID
from dual;
end;
/
ALTER TRIGGER "GIS"."WASTEWATERSEGMENT_TR" ENABLE;
-----

-- Sequence and Trigger WATERCOURSELINE_TR
-----
CREATE SEQUENCE "GIS"."WATERCOURSELINE_ID" MINVALUE 1 INCREMENT BY 1 START WITH 1
CACHE 20 NOORDER NOCYCLE;
CREATE OR REPLACE TRIGGER "GIS"."WATERCOURSELINE_TR"
before insert on WATERCOURSELINE
for each row
begin
select WATERCOURSELINE_ID.nextval
into :NEW.OBJECTID
from dual;
end;
/
ALTER TRIGGER "GIS"."WATERCOURSELINE_TR" ENABLE;
-----

-- Sequence and Trigger WATERSEGMENT_TR
-----
CREATE SEQUENCE "GIS"."WATERFEATURE_ID" MINVALUE 1 INCREMENT BY 1 START WITH 1 CACHE
20 NOORDER NOCYCLE;
CREATE OR REPLACE TRIGGER "GIS"."WATERSEGMENT_TR"
before insert on WATERSEGMENT
for each row
begin
select WATERSEGMENT_ID.nextval
into :NEW.OBJECTID
from dual;

```

```

end;
/
ALTER TRIGGER "GIS"."WATERSEGMENT_TR" ENABLE;
-----
-- Sequence and Trigger WATERFEATURE_TR
-----
CREATE SEQUENCE "GIS"."WATERNODE_ID" MINVALUE 1 INCREMENT BY 1 START WITH 965 CACHE
20 NOORDER NOCYCLE;
CREATE OR REPLACE TRIGGER "GIS"."WATERFEATURE_TR"
before insert on WATERFEATURE
for each row
begin
select WATERFEATURE_ID.nextval
into :NEW.OBJECTID
from dual;
end;
/
ALTER TRIGGER "GIS"."WATERFEATURE_TR" ENABLE;
-----
-- Sequence and Trigger WATERNODE_TR
-----
CREATE SEQUENCE "GIS"."WATERSEGMENT_ID" MINVALUE 1 INCREMENT BY 1 START WITH 530
CACHE 20 NOORDER NOCYCLE;
CREATE OR REPLACE TRIGGER "GIS"."WATERNODE_TR"
before insert on WATERNODE
for each row
begin
select WATERNODE_ID.nextval
into :NEW.OBJECTID
from dual;
end;
/
ALTER TRIGGER "GIS"."WATERNODE_TR" ENABLE;

-----
-- Synonym DUAL
-----
CREATE OR REPLACE PUBLIC SYNONYM "DUAL" FOR "SYS"."DUAL";

COMMIT;
EXIT;

```

TRB OVERSIGHT COMMITTEE FOR THE STRATEGIC HIGHWAY RESEARCH PROGRAM 2*

CHAIR: **Kirk T. Steudle**, *Director, Michigan Department of Transportation*

MEMBERS

H. Norman Abramson, *Executive Vice President (retired), Southwest Research Institute*
Alan C. Clark, *MPO Director, Houston–Galveston Area Council*
Frank L. Danchetz, *Vice President, ARCADIS-US, Inc. (deceased January 2015)*
Malcolm Dougherty, *Director, California Department of Transportation*
Stanley Gee, *Executive Deputy Commissioner, New York State Department of Transportation*
Mary L. Klein, *President and CEO, NatureServe*
Michael P. Lewis, *Director, Rhode Island Department of Transportation*
John R. Njord, *Executive Director (retired), Utah Department of Transportation*
Charles F. Potts, *Chief Executive Officer, Heritage Construction and Materials*
Ananth K. Prasad, *Secretary, Florida Department of Transportation*
Gerald M. Ross, *Chief Engineer (retired), Georgia Department of Transportation*
George E. Schoener, *Executive Director, I-95 Corridor Coalition*
Kumares C. Sinha, *Olson Distinguished Professor of Civil Engineering, Purdue University*
Paul Trombino III, *Director, Iowa Department of Transportation*

EX OFFICIO MEMBERS

Victor M. Mendez, *Administrator, Federal Highway Administration*
David L. Strickland, *Administrator, National Highway Transportation Safety Administration*
Frederick “Bud” Wright, *Executive Director, American Association of State Highway and Transportation Officials*

LIAISONS

Ken Jacoby, *Communications and Outreach Team Director, Office of Corporate Research, Technology, and Innovation Management, Federal Highway Administration*
Tony Kane, *Director, Engineering and Technical Services, American Association of State Highway and Transportation Officials*
Jeffrey F. Paniati, *Executive Director, Federal Highway Administration*
John Pearson, *Program Director, Council of Deputy Ministers Responsible for Transportation and Highway Safety, Canada*
Michael F. Trentacoste, *Associate Administrator, Research, Development, and Technology, Federal Highway Administration*

*Membership as of January 2015.

RENEWAL TECHNICAL COORDINATING COMMITTEE*

CHAIR: **Daniel D’Angelo**, *Recovery Acting Manager, Director and Deputy Chief Engineer, Office of Design, New York State Department of Transportation*

MEMBERS

Rachel Arulraj, *President, InfoInnovation*
Michael E. Ayers, *Consultant, Technology Services, American Concrete Pavement Association*
Thomas E. Baker, *State Materials Engineer, Washington State Department of Transportation*
John E. Breen, *Al-Rashid Chair in Civil Engineering Emeritus, University of Texas at Austin*
Steven D. DeWitt, *Chief Engineer (retired), North Carolina Turnpike Authority*
Tom W. Donovan, *Senior Right of Way Agent (retired), California Department of Transportation*
Alan D. Fisher, *Manager, Construction Structures Group, Cianbro Corporation*
Michael Hemmingsen, *Davison Transportation Service Center Manager (retired), Michigan Department of Transportation*
Bruce Johnson, *State Bridge Engineer, Oregon Department of Transportation, Bridge Engineering Section*
Leannie Kavanagh, *PhD Candidate, Seasonal Lecturer, Civil Engineering Department, University of Manitoba*
Cathy Nelson, *Technical Services Manager/Chief Engineer (retired), Oregon Department of Transportation*
John J. Robinson, Jr., *Assistant Chief Counsel, Pennsylvania Department of Transportation, Governor’s Office of General Counsel*
Ted M. Scott II, *Director, Engineering, American Trucking Associations, Inc.*
Gary D. Taylor, *Professional Engineer*
Gary C. Whited, *Program Manager, Construction and Materials Support Center, University of Wisconsin–Madison*

AASHTO LIAISON

James T. McDonnell, *Program Director for Engineering, American Association of State Highway and Transportation Officials*

FHWA LIAISONS

Steve Gaj, *Leader, System Management and Monitoring Team, Office of Asset Management, Federal Highway Administration*
Cheryl Allen Richter, *Assistant Director, Pavement Research and Development, Office of Infrastructure Research and Development, Federal Highway Administration*
J. B. “Butch” Wlaschin, *Director, Office of Asset Management, Federal Highway Administration*

CANADA LIAISON

Lance Vigfusson, *Assistant Deputy Minister of Engineering & Operations, Manitoba Infrastructure and Transportation*

*Membership as of July 2014.

Related SHRP 2 Research

Encouraging Innovation in Locating and Characterizing Underground Utilities (R01)

Utility Locating Technology Development Using Multisensor Platforms (R01B)

Innovations to Locate Stacked or Deep Utilities (R01C)

Integrating the Priorities of Transportation Agencies and Utility Companies (R15)

Identification of Utility Conflicts and Solutions (R15B)

Identification of Utility Conflicts and Solutions: Pilot Implementation of the SHRP 2 R15B Products at the Maryland State Highway Administration (R15C)