

## Real-Time Smoothness Measurements on Portland Cement Concrete Pavements During Construction

### DETAILS

---

132 pages | 8.5 x 11 | PAPERBACK

ISBN 978-0-309-12941-1 | DOI 10.17226/22767

### AUTHORS

---

Rasmussen, Robert O.; Torres, Helga N.; Karamihas, Steven M.; Fick, Gary; and Sohaney, Richard C.

BUY THIS BOOK

FIND RELATED TITLES

### Visit the National Academies Press at [NAP.edu](http://NAP.edu) and login or register to get:

---

- Access to free PDF downloads of thousands of scientific reports
- 10% off the price of print titles
- Email or social media notifications of new titles related to your interests
- Special offers and discounts



Distribution, posting, or copying of this PDF is strictly prohibited without written permission of the National Academies Press. (Request Permission) Unless otherwise indicated, all materials in this PDF are copyrighted by the National Academy of Sciences.

**The Second**  
**S T R A T E G I C   H I G H W A Y   R E S E A R C H   P R O G R A M**



**SHRP 2 REPORT S2-R06E-RR-1**

# Real-Time Smoothness Measurements on Portland Cement Concrete Pavements During Construction

**ROBERT O. RASMUSSEN, HELGA N. TORRES, AND RICHARD C. SOHANEY**  
The Transtec Group, Inc.

**STEVEN M. KARMIHAS**  
University of Michigan

**GARY FICK**  
Trinity Construction Management Services, Inc.

---

**TRANSPORTATION RESEARCH BOARD**

WASHINGTON, D.C.  
2013  
[www.TRB.org](http://www.TRB.org)

## **Subscriber Categories**

Construction

Highways

Pavements

## The Second Strategic Highway Research Program

America's highway system is critical to meeting the mobility and economic needs of local communities, regions, and the nation. Developments in research and technology—such as advanced materials, communications technology, new data collection technologies, and human factors science—offer a new opportunity to improve the safety and reliability of this important national resource. Breakthrough resolution of significant transportation problems, however, requires concentrated resources over a short time frame. Reflecting this need, the second Strategic Highway Research Program (SHRP 2) has an intense, large-scale focus, integrates multiple fields of research and technology, and is fundamentally different from the broad, mission-oriented, discipline-based research programs that have been the mainstay of the highway research industry for half a century.

The need for SHRP 2 was identified in *TRB Special Report 260: Strategic Highway Research: Saving Lives, Reducing Congestion, Improving Quality of Life*, published in 2001 and based on a study sponsored by Congress through the Transportation Equity Act for the 21st Century (TEA-21). SHRP 2, modeled after the first Strategic Highway Research Program, is a focused, time-constrained, management-driven program designed to complement existing highway research programs. SHRP 2 focuses on applied research in four areas: Safety, to prevent or reduce the severity of highway crashes by understanding driver behavior; Renewal, to address the aging infrastructure through rapid design and construction methods that cause minimal disruptions and produce lasting facilities; Reliability, to reduce congestion through incident reduction, management, response, and mitigation; and Capacity, to integrate mobility, economic, environmental, and community needs in the planning and designing of new transportation capacity.

SHRP 2 was authorized in August 2005 as part of the Safe, Accountable, Flexible, Efficient Transportation Equity Act: A Legacy for Users (SAFETEA-LU). The program is managed by the Transportation Research Board (TRB) on behalf of the National Research Council (NRC). SHRP 2 is conducted under a memorandum of understanding among the American Association of State Highway and Transportation Officials (AASHTO), the Federal Highway Administration (FHWA), and the National Academy of Sciences, parent organization of TRB and NRC. The program provides for competitive, merit-based selection of research contractors; independent research project oversight; and dissemination of research results.

SHRP 2 Report S2-R06E-RR-1

ISBN: 978-0-309-12941-1

Library of Congress Control Number: 2013934197

© 2013 National Academy of Sciences. All rights reserved.

### Copyright Information

Authors herein are responsible for the authenticity of their materials and for obtaining written permissions from publishers or persons who own the copyright to any previously published or copyrighted material used herein.

The second Strategic Highway Research Program grants permission to reproduce material in this publication for classroom and not-for-profit purposes. Permission is given with the understanding that none of the material will be used to imply TRB, AASHTO, or FHWA endorsement of a particular product, method, or practice. It is expected that those reproducing material in this document for educational and not-for-profit purposes will give appropriate acknowledgment of the source of any reprinted or reproduced material. For other uses of the material, request permission from SHRP 2.

*Note:* SHRP 2 report numbers convey the program, focus area, project number, and publication format. Report numbers ending in “w” are published as web documents only.

### Notice

The project that is the subject of this report was a part of the second Strategic Highway Research Program, conducted by the Transportation Research Board with the approval of the Governing Board of the National Research Council.

The members of the technical committee selected to monitor this project and review this report were chosen for their special competencies and with regard for appropriate balance. The report was reviewed by the technical committee and accepted for publication according to procedures established and overseen by the Transportation Research Board and approved by the Governing Board of the National Research Council.

The opinions and conclusions expressed or implied in this report are those of the researchers who performed the research and are not necessarily those of the Transportation Research Board, the National Research Council, or the program sponsors.

The Transportation Research Board of the National Academies, the National Research Council, and the sponsors of the second Strategic Highway Research Program do not endorse products or manufacturers. Trade or manufacturers' names appear herein solely because they are considered essential to the object of the report.



### SHRP 2 Reports

Available by subscription and through the TRB online bookstore:

[www.TRB.org/bookstore](http://www.TRB.org/bookstore)

Contact the TRB Business Office:  
202-334-3213

More information about SHRP 2:  
[www.TRB.org/SHRP2](http://www.TRB.org/SHRP2)



# THE NATIONAL ACADEMIES

## *Advisers to the Nation on Science, Engineering, and Medicine*

The **National Academy of Sciences** is a private, nonprofit, self-perpetuating society of distinguished scholars engaged in scientific and engineering research, dedicated to the furtherance of science and technology and to their use for the general welfare. On the authority of the charter granted to it by Congress in 1863, the Academy has a mandate that requires it to advise the federal government on scientific and technical matters. Dr. Ralph J. Cicerone is president of the National Academy of Sciences.

The **National Academy of Engineering** was established in 1964, under the charter of the National Academy of Sciences, as a parallel organization of outstanding engineers. It is autonomous in its administration and in the selection of its members, sharing with the National Academy of Sciences the responsibility for advising the federal government. The National Academy of Engineering also sponsors engineering programs aimed at meeting national needs, encourages education and research, and recognizes the superior achievements of engineers. Dr. Charles M. Vest is president of the National Academy of Engineering.

The **Institute of Medicine** was established in 1970 by the National Academy of Sciences to secure the services of eminent members of appropriate professions in the examination of policy matters pertaining to the health of the public. The Institute acts under the responsibility given to the National Academy of Sciences by its congressional charter to be an adviser to the federal government and, on its own initiative, to identify issues of medical care, research, and education. Dr. Harvey V. Fineberg is president of the Institute of Medicine.

The **National Research Council** was organized by the National Academy of Sciences in 1916 to associate the broad community of science and technology with the Academy's purposes of furthering knowledge and advising the federal government. Functioning in accordance with general policies determined by the Academy, the Council has become the principal operating agency of both the National Academy of Sciences and the National Academy of Engineering in providing services to the government, the public, and the scientific and engineering communities. The Council is administered jointly by both Academies and the Institute of Medicine. Dr. Ralph J. Cicerone and Dr. Charles M. Vest are chair and vice chair, respectively, of the National Research Council.

The **Transportation Research Board** is one of six major divisions of the National Research Council. The mission of the Transportation Research Board is to provide leadership in transportation innovation and progress through research and information exchange, conducted within a setting that is objective, interdisciplinary, and multimodal. The Board's varied activities annually engage about 7,000 engineers, scientists, and other transportation researchers and practitioners from the public and private sectors and academia, all of whom contribute their expertise in the public interest. The program is supported by state transportation departments, federal agencies including the component administrations of the U.S. Department of Transportation, and other organizations and individuals interested in the development of transportation. **[www.TRB.org](http://www.TRB.org)**

**[www.national-academies.org](http://www.national-academies.org)**

## SHRP 2 STAFF

**Ann M. Brach**, *Director*  
**Stephen J. Andrie**, *Deputy Director*  
**Neil J. Pedersen**, *Deputy Director, Implementation and Communications*  
**James Bryant**, *Senior Program Officer, Renewal*  
**Kenneth Campbell**, *Chief Program Officer, Safety*  
**JoAnn Coleman**, *Senior Program Assistant, Capacity and Reliability*  
**Eduardo Cusicanqui**, *Financial Officer*  
**Walter Diewald**, *Senior Program Officer, Safety*  
**Jerry DiMaggio**, *Implementation Coordinator*  
**Shantia Douglas**, *Senior Financial Assistant*  
**Charles Fay**, *Senior Program Officer, Safety*  
**Carol Ford**, *Senior Program Assistant, Renewal and Safety*  
**Elizabeth Forney**, *Assistant Editor*  
**Jo Allen Gause**, *Senior Program Officer, Capacity*  
**Rosalind Gomes**, *Accounting/Financial Assistant*  
**Abdelmenane Hedhli**, *Visiting Professional*

**James Hedlund**, *Special Consultant, Safety Coordination*  
**Alyssa Hernandez**, *Reports Coordinator*  
**Ralph Hessian**, *Special Consultant, Capacity and Reliability*  
**Andy Horosko**, *Special Consultant, Safety Field Data Collection*  
**William Hyman**, *Senior Program Officer, Reliability*  
**Michael Marazzi**, *Senior Editorial Assistant*  
**Linda Mason**, *Communications Officer*  
**Reena Mathews**, *Senior Program Officer, Capacity and Reliability*  
**Matthew Miller**, *Program Officer, Capacity and Reliability*  
**Michael Miller**, *Senior Program Assistant, Capacity and Reliability*  
**David Plazak**, *Senior Program Officer, Capacity*  
**Monica Starnes**, *Senior Program Officer, Renewal*  
**Onno Tool**, *Visiting Professional*  
**Dean Trackman**, *Managing Editor*  
**Connie Woldu**, *Administrative Coordinator*  
**Patrick Zelinski**, *Communications/Media Associate*

## ACKNOWLEDGMENTS

This work was sponsored by the Federal Highway Administration in cooperation with the American Association of State Highway and Transportation Officials. It was conducted in the second Strategic Highway Research Program, which is administered by the Transportation Research Board of the National Academies. The project was managed by Dr. James Bryant, Senior Program Officer for SHRP 2 Renewal.

The authors acknowledge numerous organizations for their support during the field evaluation and field demonstrations during this project. The research team thanks the state departments of transportation and other agencies for their cooperation: Georgia Department of Transportation, Arkansas Highway and Transportation Department, Texas Department of Transportation, Michigan Department of Transportation, New York State Thruway Authority, and the New York State Department of Transportation.

Equally as important to the success of this project were the contractors: The Scruggs Company, Interstate Highway Construction, Northgate Constructors, and Cold Spring Construction Company. They allowed us to conduct the field evaluations and demonstrations of real-time smoothness measuring technologies. Their cooperation surpassed the research team's expectations, and their flexibility, genuine interest, and willingness to help are greatly appreciated. The cooperation from GOMACO Corporation and Ames Engineering was also critical to this project. Their diligence throughout this study is an expression of their commitment to advance these technologies and, ultimately, the construction of smoother concrete pavements.

Several members of these organizations were involved. The team thanks the following individuals: Rod Pedersen, Danny Lewis, and James Turner, Georgia DOT; John Romaine and Arturo Ovando, The Scruggs Company; David Ross, Mark Evans, and Mark Greenwood, Arkansas HTD; Cal Thomas, Brian Huffman, and Tom Rutkoski, Interstate Highway Construction; Kim Soucek, Texas DOT; David Santin and Amy Bell, Northgate Constructors; Kelby Wallace and Andy Bennett, Michigan DOT; David Mellen, New York State Thruway Authority; Bill Cuerdon, New York State DOT; Jeff Borden and Bill Stewart, Cold Spring Construction Company; Kevin Klein, Mark Brenner, and Craig Rupert, GOMACO Corporation; and Jon Klatt, Ryan Emerson, and Mark Leichty, Ames Engineering, Inc. The research team also thanks Dr. Buzz Powell from the National Center for Asphalt Technology for his assistance in the profiling effort, along with others on our project team, including Sabrina Garber, R. P. Watson, Matt Pittman, and Jennifer Rutledge. Finally, the team thanks Dr. James Bryant for his guidance and trust.

## FOREWORD

James W. Bryant, Jr., *SHRP 2 Senior Program Officer, Renewal*

This report documents the evaluation and demonstration of real-time smoothness measuring technologies on Portland Cement Concrete (PCC) pavements during construction. The initial investigation gathered information on the measurement concepts and the sensor configuration of seven real-time smoothness technologies. After a detailed assessment of the seven technologies, two technologies were chosen for inclusion in the field testing. The report and model specifications developed under this project are a result of testing real-time smoothness devices in the field on actual paving projects in Arkansas, Texas, Michigan, Georgia, and New York. The lessons learned from the field demonstrations were used to improve guidance on the use of real-time smoothness technologies. It is intended to improve process control and allow for equipment and operations adjustments to correct surface irregularities while the PCC is in a plastic state. The access to real-time information on surface irregularities will aid paving contractors in meeting the smoothness specification requirements of transportation agencies. This is not intended to be a replacement for a transportation agency's quality assurance (acceptance) testing.

---

Smooth concrete pavements have been shown to be more durable, have lower vehicle operating costs, and lower maintenance and rehabilitation costs. In addition, transportation agencies recognize the importance of smooth-riding pavements to the traveling public. Most states have implemented smoothness specifications for concrete pavements that require measurement of surface profile on the finished pavement for acceptance testing. In these cases there is no indication of smoothness prior to testing on the finished concrete pavement and problems are not corrected in real time, resulting in significant expenditures to correct surface irregularities. There are several real-time smoothness measurement technologies that are at various stages of development. This study evaluated the technologies, selected technologies for field testing, and suggested improvements for the technology's use. These technologies have been shown to improve process control and allow for equipment and operations adjustments to correct surface irregularities while the concrete is still in plastic. This has resulted in higher quality, lower cost, and faster construction that will minimize the impact on the traveling public.

## C O N T E N T S

|     |   |
|-----|---|
| 1   | Executive Summary   |
| 3   | <b>CHAPTER 1</b> Introduction   |
| 3   | Objectives  |
| 3   | Scope   |
| 5   | <b>CHAPTER 2</b> Research Approach  |
| 5   | Technology Review and Recommendations   |
| 8   | Technology Field Evaluation   |
| 27  | Technology Demonstrations   |
| 48  | <b>CHAPTER 3</b> Findings and Applications  |
| 48  | Summary of Technology Performance   |
| 48  | Summary of Technology Refinements   |
| 48  | Development of Specifications and Guidelines  |
| 55  | <b>CHAPTER 4</b> Conclusions and Summary<br>of Recommendations  |
| 55  | Conclusions   |
| 55  | Summary of Recommendations  |
| 58  | References  |
| 59  | Appendix A. Phase 2—Field Evaluation: Paving Process Overview   |
| 63  | Appendix B. Phase 2—Field Evaluation: Hardened Pavement Profile<br>Measurement Experiment                           |
| 72  | Appendix C. Phase 2—Field Evaluation: Additional Information<br>Regarding Data Collection Methods and Procedures    |
| 79  | Appendix D. Phase 3—Arkansas Field Demonstration Data Reduction<br>and Analysis                                     |
| 88  | Appendix E. Phase 3—Michigan Field Demonstration Data Reduction<br>and Analysis                                     |
| 103 | Appendix F. Phase 3—New York Field Demonstration Data Reduction<br>and Analysis                                     |
| 108 | Appendix G. Phase 3—Field Demonstrations: Additional Information  |
| 127 | Appendix H. Recommended Practice for Real-Time Smoothness Measurements<br>on Concrete Pavements During Construction |

# Executive Summary

This report presents the findings of a research study conducted to evaluate and demonstrate real-time smoothness measuring technologies for concrete paving. Real-time smoothness refers to measuring and evaluating the concrete pavement surface profile during construction, somewhere along the paving train while the concrete surface is still wet (plastic). These measurements are then used to check for objectionable profile characteristics, things that are known to happen in projects that can affect pavement smoothness. With this information, paving operations can be adjusted on the fly. Ideally, deviations are detected in real time and corrections are made such that the final hardened concrete surface can avoid being ground to achieve the smoothness requirements.

The work under this study was executed in three distinct but connected phases. Each phase served to evaluate promising and emerging technologies with the potential to measure real-time smoothness. Draft model specifications and guidelines were developed to facilitate evaluation and implementation of these technologies by state highway agencies.

Phase 1 focused on identifying all potential technologies by contacting leading transportation agencies, paving contractors, paving equipment manufacturers, and representatives of concrete pavement associations. Numerous real-time smoothness-measuring technologies were reviewed, and three of these were recommended for further evaluation; however, only two were available to participate in this study. Three additional technologies were identified, but not recommended for subsequent evaluation because they lacked technical maturity or a proven history on concrete paving applications during the time frame for this study.

Phase 2 consisted of a thorough field evaluation to evaluate objectively the most viable real-time smoothness measuring technologies identified during Phase 1, the GOMACO Smoothness Indicator (GSI) and Ames Engineering Real Time Profiler (RTP). The research team worked closely with the two technology vendors, an experienced paving contractor, and a host agency. During Phase 2, both real-time profilers demonstrated adequate performance as tools for construction quality control. However, it was clear that these technologies are not suitable for quality assurance devices or for calculation of pay adjustments for smoothness.

These findings were corroborated during Phase 3, which consisted of a series of additional field demonstrations throughout the nation. Broad and specific enhancements for these technologies were provided to the vendors at the end of Phase 2, and the most critical issues were addressed during Phase 3. During this phase, the GSI was demonstrated in Arkansas and Michigan, and the Ames Engineering RTP was demonstrated in Texas, Michigan, and New York.

This report provides documentation of the field data and performance of these technologies as captured during the three project phases. In general, it was found that the two technologies evaluated in the field have

- Reasonable agreement to reference profiles;
- An ability to provide a relative estimate of roughness; and
- An ability to recognize areas where roughness accumulates the most aggressively (i.e., localized roughness).

**2**

It must be reemphasized that these technologies are not a replacement for conventional profiling for quality assurance (acceptance) or better practices for constructing smoother pavements. Furthermore, it is envisioned that the real value of the work conducted under this effort consists of providing:

- Validation of innovative tools that can be used to evaluate concrete pavement smoothness in real time;
- Tools that can be used for quality control;
- Tools that can reduce must-grinds and thus reduce project delays and claims; and
- Improved understanding about which construction artifacts can affect smoothness:
  - String line effects,
  - Concrete loading and delivery effects,
  - Dowel baskets and transverse reinforcement effects,
  - Finishing effects, and
  - Localized roughness.

Finally, recommendations to continue implementation of these technologies include training and outreach materials, along with development of a “real-time smoothness knowledge-based system” to enhance the current technology software capabilities for real-time profiler analysis.

## CHAPTER 1

# Introduction

A pavement profile is affected by numerous design and construction factors. Understanding the relationship that exists between these factors and the as-constructed pavement profile is beneficial. Knowing what that profile is in real time adds that much more value. With it, paving operations can be adjusted “on the fly” to maintain or improve smoothness. Real-time measurements can allow paving crews to adopt better practices, leading to improved smoothness. The quality of the pavement can be enhanced as a result and, with it, increased durability and comfort to the user. Because of the potential for such improvements, facilitating the adoption of real-time control of concrete pavement smoothness during construction is an industry need that this SHRP 2 study seeks to fulfill.

At the core of this study, technologies to measure smoothness in real time were evaluated and demonstrated, and model specifications and guidelines were drafted. The project was divided into three phases:

- Phase 1 identified potential technologies for real-time smoothness measurements.
- Phase 2 evaluated the most viable technologies.
- Phase 3 refined and demonstrated these technologies to meet the overall objectives of this project.

The report organization follows the technology review, evaluation, and demonstration process conducted throughout this study. This chapter identifies the overall objectives and scope of the project. Chapter 2 details the real-time smoothness measuring technology review conducted during Phase 1, the field evaluation conducted during Phase 2, and the technology refinements and four field demonstrations conducted during Phase 3. Chapter 3 presents a summary of technology refinements and performance along with draft model specifications and construction guidelines developed to facilitate the implementation of real-time smoothness measuring technologies

by state highway agencies and concrete paving contractors. The report concludes in Chapter 4 with a summary of recommendations for follow-up work necessary to continue development and implementation of these technologies.

## Objectives

The overall objective of this study is to enable real-time control of concrete pavement smoothness during construction. To assist in meeting this goal, two specific objectives were addressed:

1. Evaluation and demonstration of promising technologies that have the potential to meet the technical challenges posed by this problem; and
2. Development of both model specifications and construction guidance that are capable of working with the identified technology in such a way as to further the objective of rapid implementation by state highway agencies.

## Scope

This study was executed in three distinct but connected phases. Although the phases involved a variety of tasks, the major work elements revolved around the technologies to measure and interpret concrete pavement smoothness in real time during construction.

Phase 1 focused on identifying all potential technologies capable of assessing concrete pavement smoothness in real time. Phase 2 focused on coordinating with the vendors of the two field-ready technologies at the time of this study, the paving contractor, and the host agency to evaluate the two real-time smoothness measurement devices, under the same rule-set and nominal field conditions. Phase 3 consisted of four field demonstrations of the real-time devices in different locations around the country, involving concrete paving

**4**

projects with a variety of design features, different contractors, and different equipment.

The research team was guided by what an ideal real-time smoothness measuring system would be, which goes beyond determining smoothness statistics. Such a system would be

capable of identifying objectionable profile characteristics and their causes. Specifications and construction guidelines could be used along with such a technology, thus completing a system with the ability to monitor, assess, and respond to a concrete pavement profile in real time.



## CHAPTER 2

# Research Approach

### Technology Review and Recommendations

A combination of telephone calls, broadcast e-mails, and web-site postings were made to invite equipment vendors to demonstrate their technologies as part of this study. Target telephone calls were also made to known real-time smoothness measuring technology vendors, stringless paving technology vendors, and surveying equipment vendors. Web postings and broadcast e-mails were used via the following entities: SHRP 2 Road Profiler Users Group, American Concrete Pavement Association (ACPA), and Transportation Research Board's (TRB's) surface properties committees. These committees were Vehicle Interaction (AFD90), and Portland Cement Concrete Pavement Construction (AFH50). A posting was also made on the FHWA ProVAL website. In addition, presentations were made at the TRB AFH50 committee midyear meeting and the 2009 ACPA chapter and state division midyear meeting to facilitate test section identification for the field testing and demonstrations for Phases 2 and 3.

Stemming from the numerous announcements to solicit participation in this study, six potential real-time smoothness measuring systems were identified. Device information, such as a description of the overall measurement concept and device configuration, was then requested from these vendors. From initial discussions with vendors, the research team learned that some of the technologies were not yet proved and were instead still in the early or conceptual stages of development.

It was decided before soliciting interest that the field testing conducted under this study needed to be limited to devices that had been already demonstrated successfully on an actual paving project. This decision was deemed imperative to ensure that the field evaluations and demonstrations part of Phase 2 and Phase 3 did not adversely interfere with the paving operations and thus contractor performance. It was important that

vendors with untested equipment not be allowed to impede the operations, compared with those who have sufficiently prepared and are well aware of the challenges of working within the confines of a concrete paving operation.

It was expected that the vendors, rather than the contractor, were going to operate their equipment and that some troubleshooting was going to be needed. However, vendors were expected to have enough genuine field experience with their equipment to avoid major delays associated with mounting problems, software bugs, lack of ruggedness for field operations, insufficient electrical power, temperature sensitivity, and poor sensor function on wet concrete.

As part of the solicitation of interest, vendors with potential technologies under development, but not successfully proved in the field, were given a 2-month period to demonstrate their technologies to be included in this study. This provided a way to distinguish vendors with equipment under ongoing development from those at the early and hypothetical concept stage.

This chapter provides descriptions of the real-time smoothness measuring systems recommended for evaluation in Phase 2. It also provides a brief overview of other potential technologies for real-time smoothness measurements that had not been sufficiently demonstrated to qualify for field evaluation and demonstration as part of this study.

### **GOMACO Smoothness Indicator: GOMACO Corporation**

The GOMACO Smoothness Indicator (GSI) is a smoothness measuring device that can be attached to the paving equipment or can stand alone, mounted onto the GSI vehicle. The stand-alone setup shown in Figure 2.1 allows for smoothness measurements not only in real time, but also on the final surface, as would normally be evaluated with profilographs or lightweight profilers.

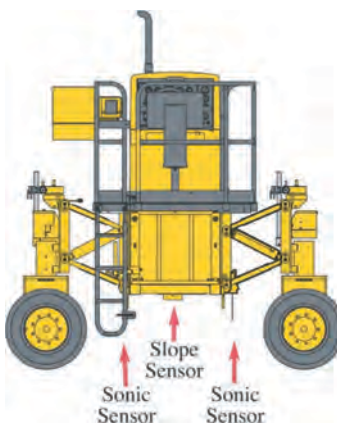


Source: GOMACO Corporation.

**Figure 2.1. GOMACO GSI equipment.**

The GSI frame can be adapted to take simultaneous readings for up to eight traces (nominally, wheelpaths spanning a width of up to four lanes). The device combines two sonic sensors and a slope sensor on each trace as shown in Figure 2.2. The readings reportedly bridge a 6-in. footprint.

Additional features of the GSI are real-time graphic displays, a printer, and its modular frame that is able to straddle over the pavement, making the GSI a noncontact device relatively isolated from the paving operation and resulting vibrations. It calculates smoothness statistics such as the international roughness index (IRI) and the profile index (PI); however, the statistics calculated in real time vary from the calculations with measurements on the final hardened surface, a topic that will be investigated throughout this study. Last, the GSI features a



Source: GOMACO Corporation.

**Figure 2.2. Side view schematic of the GSI equipment showing all sensor locations.**

“bump alarm,” which warns the paving contractor of localized roughness events.

The GSI participated in the 2004 FHWA Profiler Round-Up, where 68 different profilers (high-speed, lightweight, slow, and walking speed) were evaluated (Karamihas 2004). In addition, recent research by the National Concrete Pavement Technology Center (CP Tech Center) evaluated the GSI and the real-time smoothness measuring device described later in the chapter (Cable et al. 2005). In this study, it was concluded that both devices were able to detect roughness in real time that can affect the final concrete pavement surface and ride quality.

It should be noted that the GSI device has seen market penetration since these early profiler evaluations and research studies. The device is used to monitor smoothness in real time by paving contractors throughout the United States and the world (GOMACO 2008; GOMACO 2007).

It was recommended that the GSI be included in Phase 2 of this research because it has been previously demonstrated and thoroughly tested in the field as it is currently used by numerous paving contractors. The pertinent communications were conducted with the vendor of this technology, and the vendor was willing and able to participate.

### Real Time Profiler: Ames Engineering

The Real Time Profiler (RTP) is a laser-based profiler that mounts directly onto the paving equipment. Multiple systems can be installed across a lane to collect data along more than one trace (e.g., wheelpath) (Figure 2.3).

The RTP features graphic displays and a printer and calculates profile and smoothness statistics (IRI, PI, and so forth) in real time. It also includes a bump or localized roughness detection feature to alert the contractor of segments not



**Figure 2.3. Ames Engineering RTP mounted behind a paver.**

meeting smoothness specifications. As previously mentioned, this device was evaluated along with the GSI, and both were able to detect roughness in real time that can affect the final profile and its ride quality.

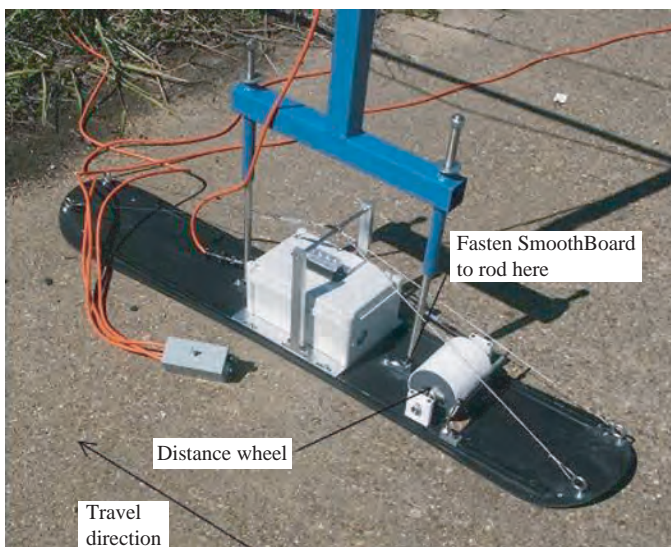
It was recommended that the RTP be included in Phase 2 of this research because it has been previously demonstrated and tested in the field. The pertinent communications were conducted with the vendor of this technology, and the vendor was willing and able to participate.

### Sliding Profiler: Texas DOT (University of Texas at Arlington and Texas Transportation Institute)

The Sliding Profiler is a patented device developed for the Texas Department of Transportation (Texas DOT) by the University of Texas at Arlington (UTA) and the Texas Transportation Institute (TTI). The device is covered by U.S. patent 7,762,144 (Walker and Fernando 2007) and, as shown in Figure 2.4, consists of a sliding platform (snowboard) that carries hardware and software to measure slope and distance as it is towed behind the paving equipment on the fresh concrete.

The primary capability of the Sliding Profiler is described to be the detection of bumps and localized roughness in real time. The development and implementation of this technology is detailed in the report by Walker and Fernando (2007).

It was recommended that the Sliding Profiler be included in Phase 2 of this research because it has been previously demonstrated and tested in the field. The pertinent communications were conducted with the developer of this technology; however, the developer was not able to participate.



Source: Walker and Fernando 2007.

**Figure 2.4. Texas DOT-UTA-TTI Sliding Profiler.**

### Dynamic Surface Profiler: Surface Systems & Instruments

Surface Systems & Instruments (SSI) informed the team of the development of the Dynamic Surface Profiler and expressed some interest in this research. The device is reportedly being developed as an attachment to either the concrete paver or texture machine. The device uses a proprietary laser and inclinometer platform to conduct its profile measurements. In addition, a line scan laser is an optional feature that assesses the pavement surface texture. The device is to provide smoothness statistics, recognize localized roughness, and provide the corresponding displays in real time.

SSI offered the Dynamic Surface Profiler as a candidate for this study. The research team requested that SSI provide confirmation and documentation of field demonstration of the device. However, this vendor was not able to conduct successful field testing within the deadline provided and withdrew from the study. As such, it was recommended that this device not be included in Phase 2 of this research.

As previously discussed, this research was intended to be limited to existing technologies that have been successfully demonstrated on an actual paving project. Inclusion of prototypes still under development could jeopardize the work under Phase 2 by interfering with the paving operations and negatively affecting the final product of the paving contractor.

### Auto Rod & Level: APR Consultants

The Auto Rod & Level (AR&L) is a profiling device that acquires elevation data relative to a laser-established reference plane as it is pushed along the pavement (see Figure 2.5).



Source: APR Consultants.

**Figure 2.5. APR Auto Rod & Level.**



APR Consultants expressed their interest in this research and their initial intention to modify the AR&L to conduct measurements in real time by installing the equipment onto the paving machine, using lighter components, and modifying their software.

APR Consultants were working on the real-time application of this device; however, it was recommended that APR not be included in Phase 2 of this research because their equipment has yet to be successfully demonstrated in the field for real-time smoothness measurements.

### Vehicle Terrain Measurement System: Virginia Tech

The Vehicle Terrain Measurement System (VTMS) was developed by the Virginia Tech Vehicle Terrain Performance Laboratory. The device conducts terrain topology measurements, converts the measurements to world coordinates, and stores the data. Figure 2.6 shows a picture of the VTMS with its scanning laser mounted 2 m above ground.

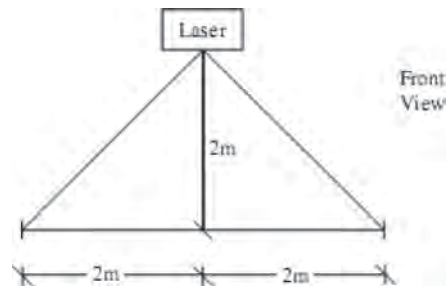
Figure 2.7 is a schematic to illustrate that the measurements of the VTMS span a width of 4 m. The device transversely scans the pavement surface and the matrix of elevation data points produces a topographical image of the pavement surface.

There is potential to modify this technology to conduct measurements on concrete pavements during construction. Further development and field testing time are needed to accomplish this, and, as a result, this device lacked the requirements to participate in this research. It was therefore recommended that the VTMS not be included in Phase 2 of this study.



Source: Virginia Tech 2008.

**Figure 2.6. Virginia Tech Vehicle Terrain Measurement System.**



Source: Virginia Tech 2008.

**Figure 2.7. Schematic of VTMS laser scanning range, front view.**

### Technology Field Evaluation

The field evaluation in Phase 2 consisted of evaluating the most viable real-time smoothness measuring technologies at the time of the study, to identify their benefits and limitations. GOMACO and Ames Engineering were invited to conduct field testing on the same paving project and to perform additional measurements, which are described in the following sections. Both vendors received a stipend to offset equipment mobilization, travel, and labor costs associated with the field evaluation.

The purpose of this evaluation was to document the measurement procedures, measurement quality, and value to a construction crew of the two real-time profile measurement devices on an active slipform concrete paving operation. Measurement procedures were documented through simple observation of each device during operation, informal interviews of each operator, and literature provided by each vendor.

Measurement quality was established by testing each device's repeatability, reproducibility, accuracy, measurement noise, and susceptibility to environmental vibration. Specialized testing beyond the typical operation of these devices, as described in this section, was also performed.

Value to a construction crew in terms of smoothness quality control was established in two ways. First, each vendor was asked to demonstrate the device, its output, and how it may be used to help a paving crew improve smoothness in real time and thus improve paving practices. Second, the research team documented cases in which each device provided output, especially in real time, that could have warned the paving crew of a problem with smoothness during live operation.

### Test Section Description

The field evaluation was conducted at the widening and reconstruction of I-75 in Cook County, Georgia (Project NH-75-1[205]), during May 6 to 12, 2010. The contractor for this project was The Scruggs Company based in Hahira, Georgia. The project was overseen by District Four of the

Georgia Department of Transportation out of their I-75 Reconstruction Area Office in Lenox, Georgia.

The project consisted of widening and reconstructing 9.85 mi with continuously reinforced concrete pavement (CRCP), 12 in. thick, with approximately 0.7% steel. The CRCP was constructed with No. 6 longitudinal bars spaced at 5 in. on-center, No. 4 transverse bars spaced at 3 ft on-center, and No. 5 tie bars 30 in. long placed at 18 in. on-center in the construction joint located 25 ft from the right (outside) shoulder. A typical section for the northbound lanes under construction during the field evaluation is provided in Appendix A.

The paving operation was thoroughly documented during the field evaluation. This information is important for identifying sources of construction variability, believed to be a critical variable in the resulting profile characteristics. This research also reviews better practice guidelines for preventing objectionable profile characteristics, and thus requires documentation of the impact to profile measurements related to the various stages of construction.

For this project, concrete was produced from a central mix batch plant located near the south end of the section, transported using dump trucks, and spread via a GOMACO PS 2600 belt placer/spreader. Consolidation and initial finishing of the pavement were accomplished with a GOMACO GHP 2800 slipform paver and, at the time of the field evaluation, a Leica stringless guidance system was used. Hand finishing of the pavement behind the paver was performed using 12-ft straightedges to fill any surface voids; smoothness was checked with a 20-ft straightedge. A transverse tined texture (nominally 0.5-in. spacing) was applied to the pavement surface with a GOMACO T/C 600 texture/cure machine. More details regarding the paving operation, including photographs, are provided in Appendix A.

### Summary of Activities, Data Collection Methods, and Procedures

Preparation for the field evaluation began on Friday, May 7, when the research team reported to the site and met with the contractor and the Georgia DOT representatives. The team conducted site reconnaissance and determined the locations for real-time profilers and supplementary instrumentation. During the weekend (May 8 and 9), the team worked with the technology vendors to mount and set up their equipment. The research team set up additional instrumentation to evaluate equipment vibrations and displacements. The contractor paved a short section on Sunday, May 9, and the team took advantage of the opportunity to conduct a “dry run” and ensure that everything was ready to begin data collection. In addition, the research team marked project stations on the pavement for quick referencing, installed pavement temperature sensors, and

conducted reference profiling with a dipstick in two areas of interest along the paver track line.

Real-time smoothness and paver vibration and displacement measurements were conducted Monday and Tuesday (May 10 and 11). Team members took detailed notes, photographs, and video to document the paving process at different stations along the paving train. Weather data were also collected at this time.

During the last day of the field evaluation (Wednesday, May 12), the research team prepared a test section on the hardened concrete that was placed and monitored for real-time smoothness on the first day (Monday, May 10). The purpose of the test section was to conduct additional measurements on the hardened concrete using the same real-time smoothness technologies, a reference profiler, and a high-speed inertial profiler.

The pertinent details regarding the principal activities and measurements conducted throughout the field evaluation, including documentation (notes) of the construction operation, smoothness (real-time, high-speed, and reference profiling), and paver vibrations and displacements follow. Appendix C contains information regarding supplementary measurements that were conducted to document macrotexture and environmental conditions and the information provided by the Georgia DOT for concrete mix design, quality control, and quality assurance.

### Documentation of Paving Operation

The purpose of the note-taking stations (Figures 2.8 and 2.9) was to attempt to link output of the real-time smoothness measuring devices (profile, bump warnings, etc.) to observations about the paving operation. Examples include paver stops, paver speed, paver (hydraulic) height adjustment, track



**Figure 2.8.** Front view of paving train and note-taking stations.



**Figure 2.9. Rear view of paving train and note-taking stations.**

line roughness, material placement ahead of the spreader, concrete head in front of the paver, auger usage, and hand-finishing activity. In addition, continuous video was collected in front of the paver to monitor the head of concrete.

More than 800 notes were compiled, each of them providing the time of day and location (station), along with an event description. When feasible, notes were supplemented with photographs. Figure 2.10 shows a snapshot of the information collected.

The first note-taking station was located in front of the spreader as shown in Figure 2.11. Notes at this location relate to the concrete delivery (time and station), visual observations regarding the consistency of the concrete mix, spreader stops and adjustments, and water truck activity.



**Figure 2.11. Note-taking station: in front of the spreader.**

The next note-taking station was located between the spreader and the paver, as shown in Figure 2.12. Notes at this location relate to the concrete head in front of the paver, paver stops and adjustments, auger usage, strike-off plate adjustments, and “leave outs” by the spreader operator to control the concrete head in front of the paver. In addition, a video camera was set up at this location to continuously monitor the events in front of the paver, particularly the concrete head.

Another note-taking station was located behind the paver, as shown in Figure 2.13. Notes at this location relate mainly to the hand-finishing operation, particularly surface corrections with straightedges and other tools.

The last set of notes was collected by the texture/cure-cart operator, who noted the time and stations for the different

| Date   | Time (with blanks) | Station  | Station Reference  | Category        | Note/Event/Description   | Photo |
|--------|--------------------|----------|--------------------|-----------------|--|-------|
| May-11 | 10:00 AM           | 511+03   | Transtec 5th wheel | Paver status    | Paver stop (waiting on concrete load/spreader stopped)                     |       |
| May-11 | 10:10 AM           | 511+40   | Transtec 5th wheel | Leica system    | Paver stop (appeared to be related to the stringless control system/leica) |       |
| May-11 | 10:19 AM           | 511+70   | Transtec 5th wheel | Paver status    | Speed reading on GSI's screen: 5 ft/min                                    |       |
| May-11 | 10:20 AM           | 511+76   | Transtec 5th wheel | Paver status    | Paver stop (waiting on concrete load/spreader stopped)                     |       |
| May-11 | 10:15 AM           | 511+85   | Transtec 5th wheel | Head & holes    | Concrete head in front of paver "LOW"; mostly on RT side                   |       |
| May-11 |                    | 512+03   | Transtec 5th wheel | Paver status    | Paver stop   |       |
| May-11 | 11:27 AM           | 513+25.5 | Transtec 5th wheel | Leica system    | Paver stop (appeared to be related to the stringless control system/leica) |       |
| May-11 |                    | 513+50   | Transtec 5th wheel | Paver status    | Paver operator adjusting augers  |       |
| May-11 | 11:39 AM           | 513+65   | Transtec 5th wheel | Paver status    | Paver stop   |       |
| May-11 |                    | 513+65   | Transtec 5th wheel | Spreader status | Paver operator told spreader operator to lower spreader                    |       |
| May-11 |                    | 513+75   | Transtec 5th wheel | Paver status    | Still lowering spreader  |       |
| May-11 | 11:44 AM           | 513+85   | Transtec 5th wheel | Head & holes    | Concrete head in front of paver "HIGH" specially @ CT                      |       |

**Figure 2.10. Snapshot of spreadsheet with construction operation notes.**





**Figure 2.12. Note-taking station: in front of the paver.**

sections as texture and curing compound were applied. Because this operation was of more casual interest (it was not monitored by any of the real-time systems), this set of notes is only available for Tuesday, May 11.

### Smoothness Measurements

#### HOT-MIX ASPHALT BASE COURSE

The first set of profile measurements for this study was conducted by the Georgia DOT District Four Profiler Operator on the hot-mix asphalt (HMA) base course (19-mm Superpave®), using a high-speed inertial profiler (see Figure 2.17). The HMA profile was measured for the left and right wheelpaths for both lanes constructed during the field evaluation. The purpose of these profile measurements on the HMA base was to identify profile characteristics that may have an impact on the final smoothness of the CRCP. For example, the contractor indicated that the granular and asphalt bases were placed with string line control with paving hubs spaced at 50 ft, along with “eyeballed” intermediate hubs in between



**Figure 2.13. Note-taking station: behind the paver.**

(25 ft). Nevertheless, these profiles were examined and no repetitive features were observed.

#### REAL-TIME PROFILE MEASUREMENTS ON CONTINUOUSLY REINFORCED CONCRETE PAVEMENT

At the core of this study, real-time profile measurements were conducted with the two devices under evaluation, the GOMACO GSI and Ames Engineering RTP. GOMACO used two independent GSI units during the field evaluation. The first unit was attached to the paver, and the second unit was a stand-alone setup mounted onto the GSI machine that was located behind the hand-finishing operation. Ames Engineering used two identical RTP units that were attached to the paver, profiling different wheelpaths. Real-time profile measurements were conducted during 2 days, May 10 and 11. All vendors installed and ran their devices per their standard operating procedures.

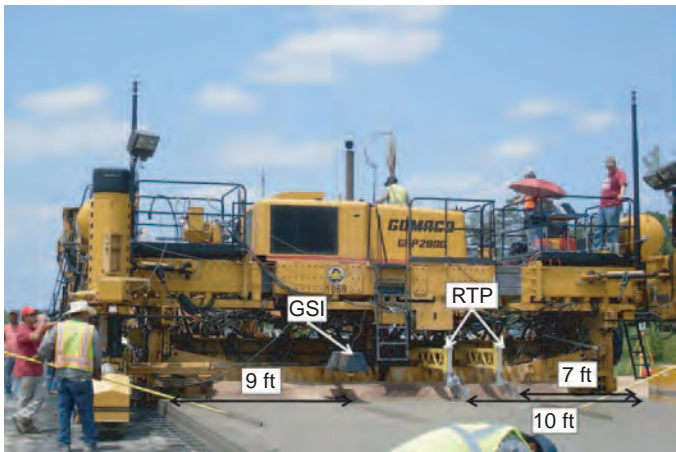
Figure 2.14 shows the location of the real-time profilers during the first day (May 10), with the paver-mounted GSI located in the center of the right lane, and the Ames Engineering RTP units measuring the left wheelpath of the right lane and the right wheelpath of the left lane.

Figure 2.15 shows that the location of the real-time profilers was switched during the second day (May 11), with the paver-mounted GSI located in the right wheelpath of the left lane, and the Ames Engineering RTP units measuring the left wheelpath and the centerline of the right lane.

Figure 2.16 shows the location of the stand-alone GSI unit, which was located behind the hand finishers. The sensors in this unit match the locations of the paver-mounted units: right wheelpath of the left lane and both the left wheelpath and center of the right lane. The profile measurements by the



**Figure 2.14. Day 1 (May 10) paver-mounted real-time profilers' setup.**



**Figure 2.15.** Day 2 (May 11) paver-mounted real-time profilers' setup.

stand-alone GSI allow for an evaluation of the repeatability of these devices as reported later in this chapter.

#### *HARDENED CONTINUOUSLY REINFORCED CONCRETE PAVEMENT SURFACE*

A 1,000-ft section paved during the first day (May 10) of the evaluation was retested during the last day (May 12), at which time the CRCP surface was strong enough to support light traffic. Repeated measurements were conducted with a reference profiler (International Cybernetics Corporation [ICC] SurPRO 2000, see Figure 2.17), a high-speed inertial profiler (Georgia DOT District Four ICC unit, see Figure 2.17), and the real-time devices (Figure 2.18). These readings matched the track lines



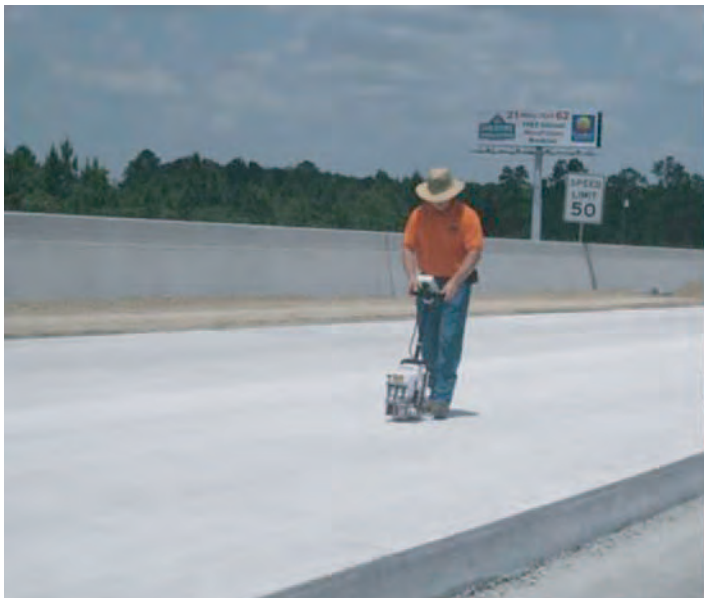
**Figure 2.16.** GOMACO GSI machine setup behind hand finishers.

profiled during the first day (May 10). The real-time and hardened surface profiles are compared to evaluate accuracy, reproducibility, and repeatability in this chapter and in Appendix B.

#### *Paver Vibrations and Displacements*

A data acquisition system was temporarily installed on the paver to measure dynamic signals such as vibration, displacements, and other motions. The purpose was to demonstrate feasibility of acquiring data during the paving operation to

- Detect if there was vibration or other dynamic motion affecting the real-time profilers mounted on the paver;



**Figure 2.17.** Hardened concrete measurements with SurPRO 2000 reference profiler (left) and the Georgia DOT high-speed inertial profiler (right).





**Figure 2.18. Hardened concrete measurements with Ames Engineering RTP (left) and GOMACO GSI (right).**

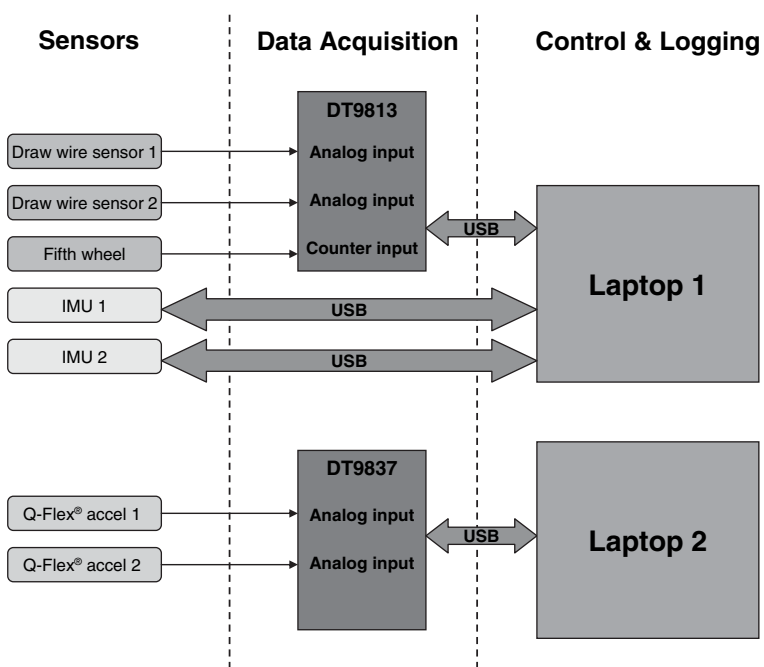
- Detect dynamic behavior of the paver that may affect road smoothness; and
- Provide real-time feedback to the paving operation.

Figure 2.19 shows a block diagram of the data acquisition system. It comprises three parts: (1) sensors, (2) data acquisition devices, and (3) acquisition control and data logging.

#### *SENSORS*

Four types of sensors were selected to mount on the paver:

1. Draw wire sensor;
2. Q-Flex accelerometer;
3. Inertial measurement unit; and
4. Fifth wheel with rotary encoder.



**Figure 2.19. Block diagram of the data acquisition system.**

Additional sensor information is provided in Table C.1 of Appendix C.

Draw wire sensors were selected for measuring changes in the height of the paver legs. Two of these sensors were used on the project. The sensor was attached to the paver by bolting it to an angle bracket, which was magnetically attached to the paver structure. Figure 2.20 shows an example of one of the draw wire sensors mounted on the paver's right front leg.

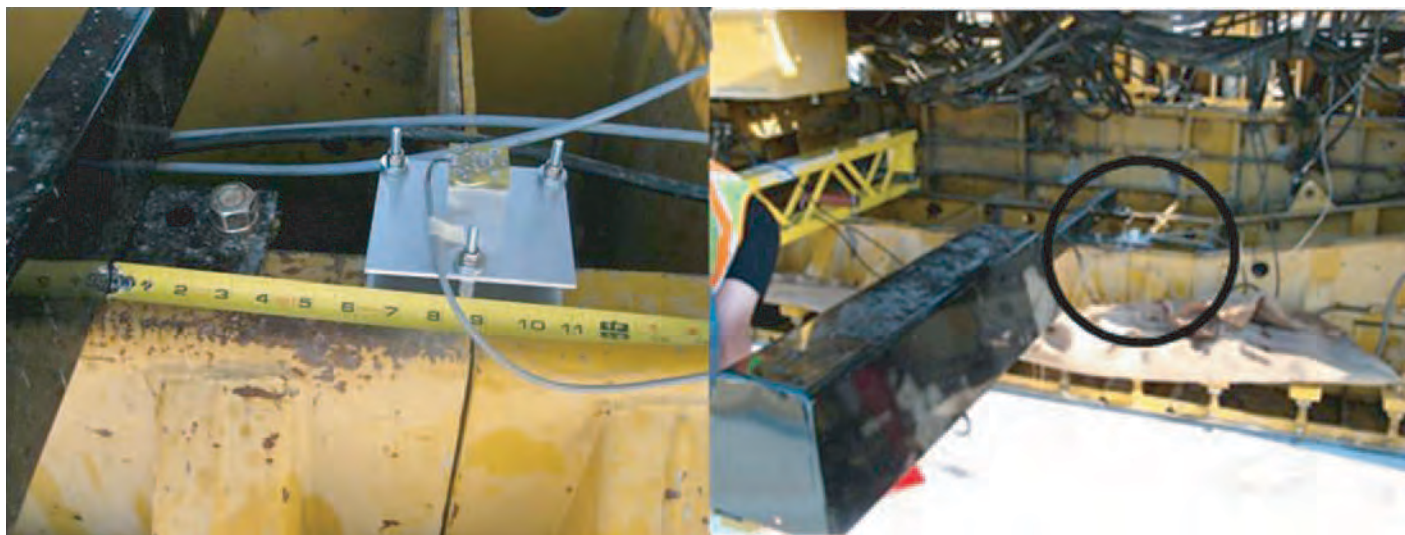
Q-Flex accelerometers were selected to measure acceleration at various locations on the paver. Two of these sensors were used on the project. These sensors were mounted to the paver by bolting them to a leveling bracket, which was magnetically attached to the paver structure. Figure 2.21 shows one of the Q-Flex accelerometers mounted on the paver. The left part of the figure is a close-up view of the accelerometer mounted on the paver. The right part of the figure shows the location of the accelerometer (identified by the black circle) relative to the finishing pan and where the GSI is attached.

Inertial measurement units (IMUs) were selected to measure acceleration and orientation (inclination) at various locations on the paver. Two of these sensors were used on the project. The IMUs were mounted to the paver by bolting them to a leveling bracket, which was magnetically attached to the paver structure. Figure 2.22 shows one of the IMU sensors mounted on the paver. On the left is a close-up view of the IMU and to the right is a view showing the location of the IMU on the paver (identified by the black circle). It is at the center of the paver above the rear of the finishing pan.

A digital rotary encoder mounted on the shaft of a wheel of known diameter was selected to measure paver travel distance and velocity. The wheel plus encoder, often referred to as a fifth wheel, was magnetically attached to the side of the paver so that it rolled along the track surface as the paver

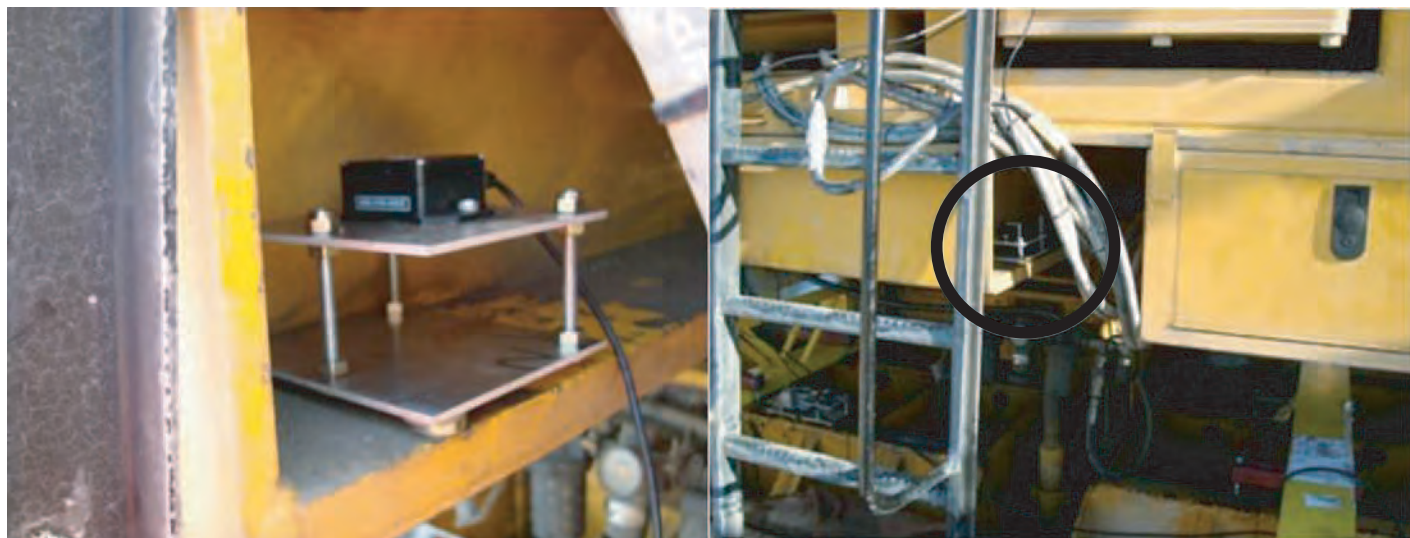


**Figure 2.20. Draw wire sensor mounted on leg of paver.**



**Figure 2.21. Q-Flex accelerometer mounting.**





**Figure 2.22.** IMU mounted on the paver.

moved. Figure 2.23 shows the fifth wheel mounted to the paver, to the outside of the right front track. The rotary encoder is mounted to the shaft of the wheel.

#### *SENSOR MOUNTING LOCATIONS*

Table 2.1 summarizes the sensor mounting locations for both days of paving operations. Cables from all sensors were routed from the sensor mounting location to the paver operator deck where the data acquisition devices and laptop computers were located.

#### *DATA ACQUISITION DEVICES*

The data acquisition devices perform signal conditioning, analog to digital conversion, data buffering, and input–output.



**Figure 2.23.** Fifth wheel mounted to the paver.

Two USB-based data acquisition devices were selected for use, Data Translation Model DT9813 and Model DT9837:

- Model DT9813: The signal from the fifth wheel was connected to the counter input. Signals from the draw wire sensors were connected to the analog inputs.
- Model DT9837: Signals from the Q-Flex accelerometers were connected to the analog inputs.

Both these data acquisition devices were connected to laptop computers via USB. The IMU sensors have built-in sampling and data processing. These sensors connect directly to the laptop computer via USB.

#### *ACQUISITION CONTROL AND DATA LOGGING*

National Instruments LabVIEW system design software running on two laptop computers was used to configure the data acquisition devices, start and stop measurements, and store the data in files on the hard drives. The format of the data log files is text using comma-separated values.

The data acquisition system operated the full length of the paving operation for each day. Except for the fifth wheel, there were periodic, planned breaks in the measurements to start new data files. This helped to avoid excessively large data files. Breaks to start new data files occurred at 45- to 60-min intervals and lasted approximately 60 to 90 s. They usually occurred at times when the paver was idling (not moving). The measurement breaks did not apply to the signal from the fifth wheel. There is a continuous, uninterrupted log of fifth wheel data for each day.

#### *TEMPORARY TEST OPERATOR'S STATION*

A temporary test operator's station was set up on the paver's deck (Figure 2.24). Power for the laptops was obtained from

**Table 2.1. Summary of the Sensor Mounting Locations**

| Sensor               | Quantity | Mounting Location   |  |
|----------------------|----------|---|--|
|                      |          | Day 1 (5/10/2010)   | Day 2 (5/11/2010)  |
| Draw wire            | 2        | (1) Right front leg<br>(2) Right rear leg   | (1) Left rear leg<br>(2) Right rear leg  |
| Q-Flex accelerometer | 2        | (1) Rear of the finishing pan near where GOMACO's profiler is mounted<br>(2) Rear of finishing pan near where Ames' profiler is mounted | (1) On top of the Ames' profiler<br>(2) On top of the beam supporting GOMACO's profiler                                      |
| IMU                  | 2        | (1) Center of paver above the rear of the finishing pan<br>(2) Rear of finishing pan near where Ames' profiler is mounted               | (1) Rear of finishing pan near where GOMACO's profiler is mounted<br>(2) Center of paver above the rear of the finishing pan |
| Rotary encoder       | 1        | (1) On the right side of the paving kit (between the tracks)  | (1) On the outside of the right front track  |

the paver's generator and batteries were used to provide low-voltage power to those sensors that required it. Thus the entire data acquisition system was completely contained on, and traveled with, the paver. There were no cables or signals routed to devices located off the paver or alongside the road.

### Supplementary Testing

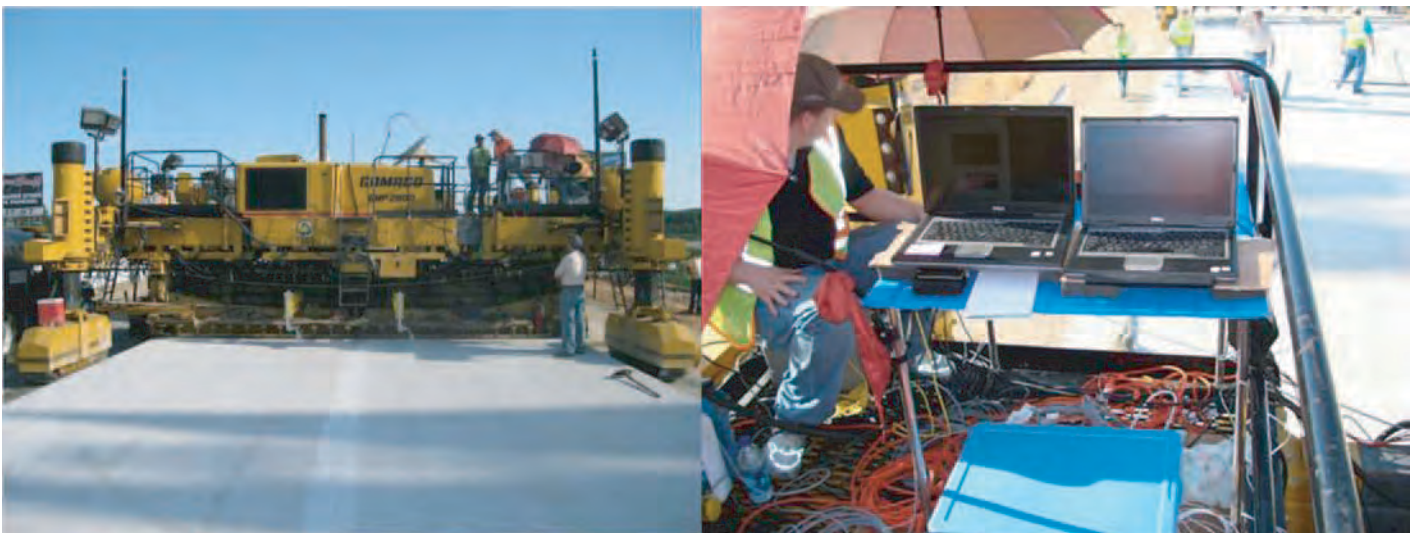
In addition to the paving operation documentation (notes), smoothness measurements, and paver displacement and vibration measurements described in the preceding sections, supplementary testing was conducted and is documented in Appendix C. These tests involved macrotexture measurements of the hardened pavement surface, environmental conditions monitoring (temperature, humidity, dew point, wind speed,

wind direction, and barometric pressure), and pavement surface temperatures.

In addition, concrete material information was collected from the testing conducted by the contractor and the Georgia DOT. This information is critical if the various surface characteristics are to be tied to variables that are commonly under the control of the contractor or the agency, by either specifications or better practices. Appendix C also presents this information.

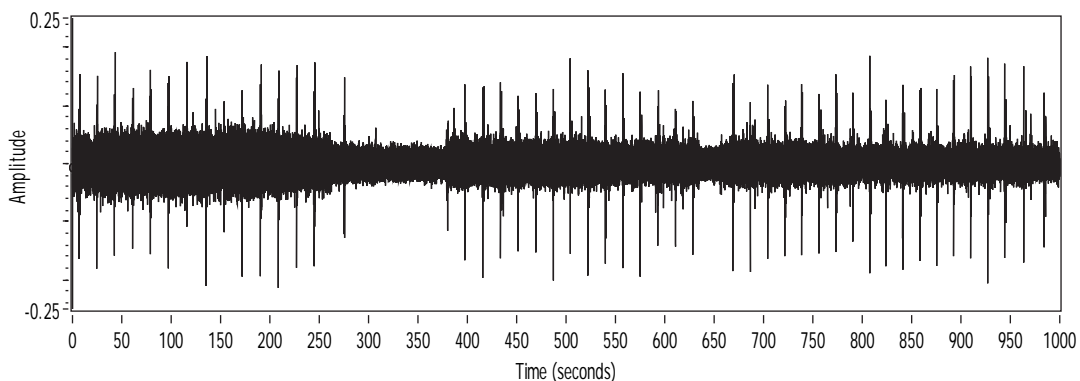
### Analysis of Events and Observations in the Field Data

This section describes a few examples of events and observations made by the team. The team also shows how these are evident in the measured data or are evident as construction artifacts.



**Figure 2.24. Temporary test operator's station on the paver deck.**





**Figure 2.25. Sample vibration (acceleration) of the paver.**

### ***Tie Bar Insertion***

Accelerometers located at various points on the rear of the paver measured vibration during the paving operations. Figure 2.25 shows a sample vibration waveform, with the amplitude being the acceleration (in units of  $g$ ). This particular sample is from the IMU sensor located at the center of the paver above the finishing pan (see Figure 2.26). The IMU sensor is a multi-axis sensor. The signal in this example is for the lateral direction, horizontal and left to right relative to the paver.

Two interesting characteristics are observed in this signal. The first characteristic observed is the narrow, transient spikes that occur at about 17-s intervals. During the paving operation, it was noticed that these spikes in the waveform occurred at the time of the tie bar insertion events. The impact associated with the tie bar insertion operation imparted a vibration into the paver that was detected by the IMU sensor. If one knows the distance between tie bars (18 in.) and can measure the interval time between insertion events in the

waveform (about 17 s), the paver velocity during this time can be estimated:  $18/17 \approx 1$  in./s.

A second characteristic observed in the signal is that there are intervals during which the spikes from tie bar insertion are not evident. This identifies times during which the paver was stopped.

### ***Trackline Bump***

During the site reconnaissance, the team observed a localized rough spot, or “bump,” in the right track line centered near Station 509+00. The track line bump is shown in Figure 2.27. This localized roughness was encountered by the paver early during the second day of paving operations.

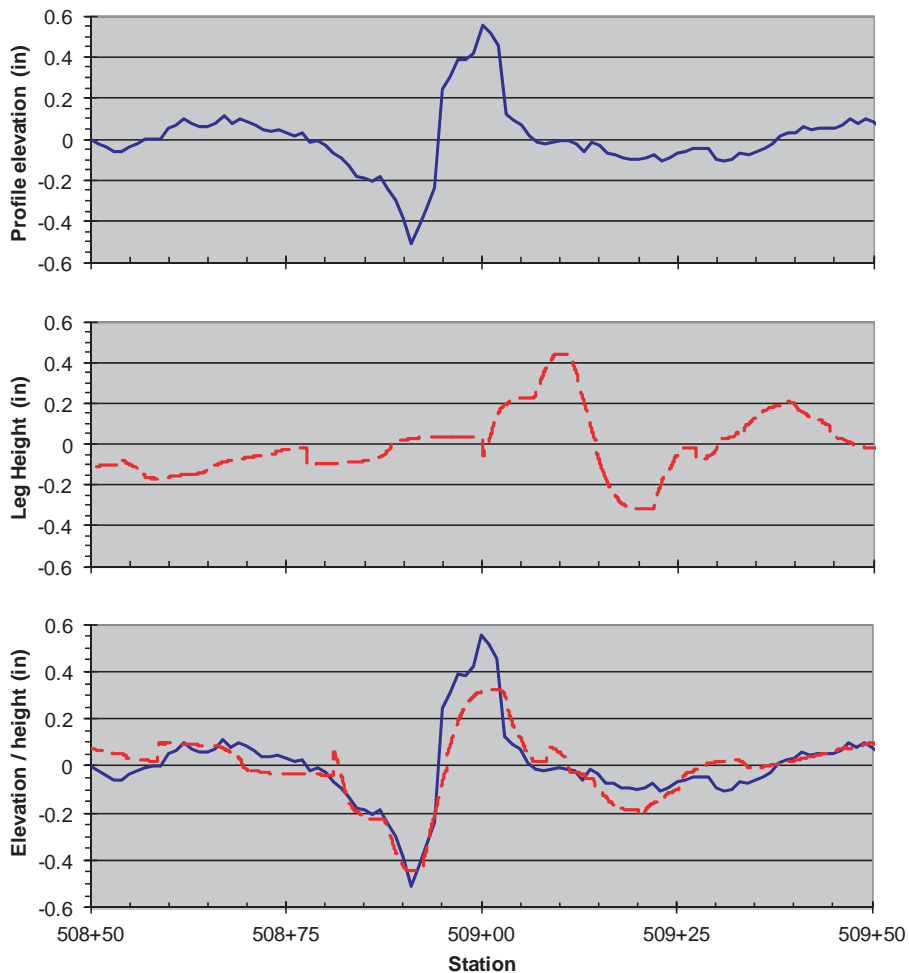
In anticipation of the need for the paver to make elevation adjustments as it traversed the bump, this event was closely monitored and documented by the team. The track line profile was measured using a Dipstick profiler ahead of the paving



**Figure 2.26. IMU sensor above the finishing pan on the paver.**



**Figure 2.27. Bump in the right track line at Station 509+00.**



**Figure 2.28. Track line bump via the Dipstick profile, right rear leg height, and combined (after adjustments).**

operations of Day 2. When the paver traversed the roughness, the signal from the draw wire sensor mounted on the right rear leg was recorded to monitor leg lift. Finally, the real-time profilers mounted on the paver measured the profiles from which the resulting roughness is calculated.

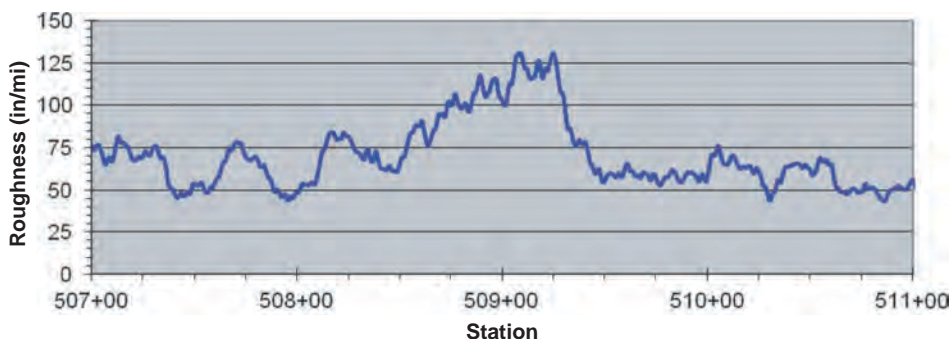
The upper graph of Figure 2.28 shows the elevation profile of the bump from Station 508+50 to Station 509+50, as measured by the Dipstick profiler. The bump consists of a ½-in. dip, followed by a ½-in.-high crest. Total change in elevation from the bottom of the dip to the top of the crest is about 1 in.

The middle graph of Figure 2.28 shows the response of the right rear leg as measured by the draw wire sensor while the paver traverses the same bump. The graph shows the leg lifts up 0.45 in. by Station 509+10 and then retracts to -0.3 in. by Station 509+20. It must be noted, however, in this graph, that the  $x$ -axis is calibrated to the station corresponding to the location of the fifth wheel which, on Day 2, was mounted about 19 ft ahead of the rear leg.

The lower graph of Figure 2.28 shows the elevation profile and leg height superimposed. In this graph, two compensations have been performed on the leg height trace:

1. There is a 19-ft shift left to compensate for the difference in  $x$ -axis calibrations. The shift corresponds to the station difference between the fifth wheel and rear leg.
2. The leg height trace has been “flipped over” to compensate for difference in sign convention between elevation profile and leg height. A downward change in profile elevation is negative. However, when the paver encounters a negative elevation change, it must extend to keep the surface smooth. Leg height increasing is positive.

With these two compensations, the leg height trace closely follows the elevation profile (see the lower graph of Figure 2.28). This is the expected behavior of the paver to maintain the surface of the pavement smooth and level.



**Figure 2.29. Roughness over the track line bump.**

Figure 2.29 shows the resulting roughness calculated from the elevation profile measured by the GOMACO GSI paver-mounted unit. Note that the  $x$ -axis in this figure covers a broader range than the graphs in Figure 2.28 showing the elevation profile and leg height. Before and after the track line bump, the maximum roughness (IRI) is about 75 in./mi. In the proximity of the bump, the roughness reaches a maximum of 130 in./mi. Thus, even though the leg height closely followed the elevation profile, the track line bump was a large enough disturbance to the paver control system that it resulted in a significant local increase in roughness.

### Laser Gun Swap Event

The GOMACO GHP 2800 paver was using a Leica stringless (laser-based) guidance system. The laser total stations or “guns” were located on tripods along the right side of the road spaced at 150- to 200-ft intervals. As the paving operation progresses and the paver travels down the road, it will eventually pass the lead laser gun. When this occurs, the Leica crew would reposition the lead gun and the second gun becomes the lead gun. This action is referred to as a “gun swap” event.

Normally, gun swap events occurred when the paver was stopped. On the first day of paving, the first gun swap occurred while the paver was stopped at Station 492+60. The team observed this gun swap event seemed to take longer than expected, and the crew operating the Leica system appeared particularly concerned and focused during the swap operation. In addition, the team noticed extra activity by the finisher with the 20-ft straightedge to smooth the pavement surface directly after the swap. Based on these cues, the team suspected the gun swap operation did not execute smoothly and thus flagged it for subsequent analysis.

The graphs in Figure 2.30 reveal how the gun swap event manifested itself in the data and final roughness. The upper graph of Figure 2.30 shows that the right rear leg lifted 0.6 in. at Station 492+60 as measured by the draw wire sensor.

Next, the middle graph of Figure 2.30 shows the profile elevation at the finishing pan as measured by the GOMACO

GSI paver-mounted unit and behind the hand finishers as measured by the GOMACO GSI stand-alone unit. From the traces, there is a large elevation change around the gun swap event. This profile is smoothed somewhat after the hand finishing.

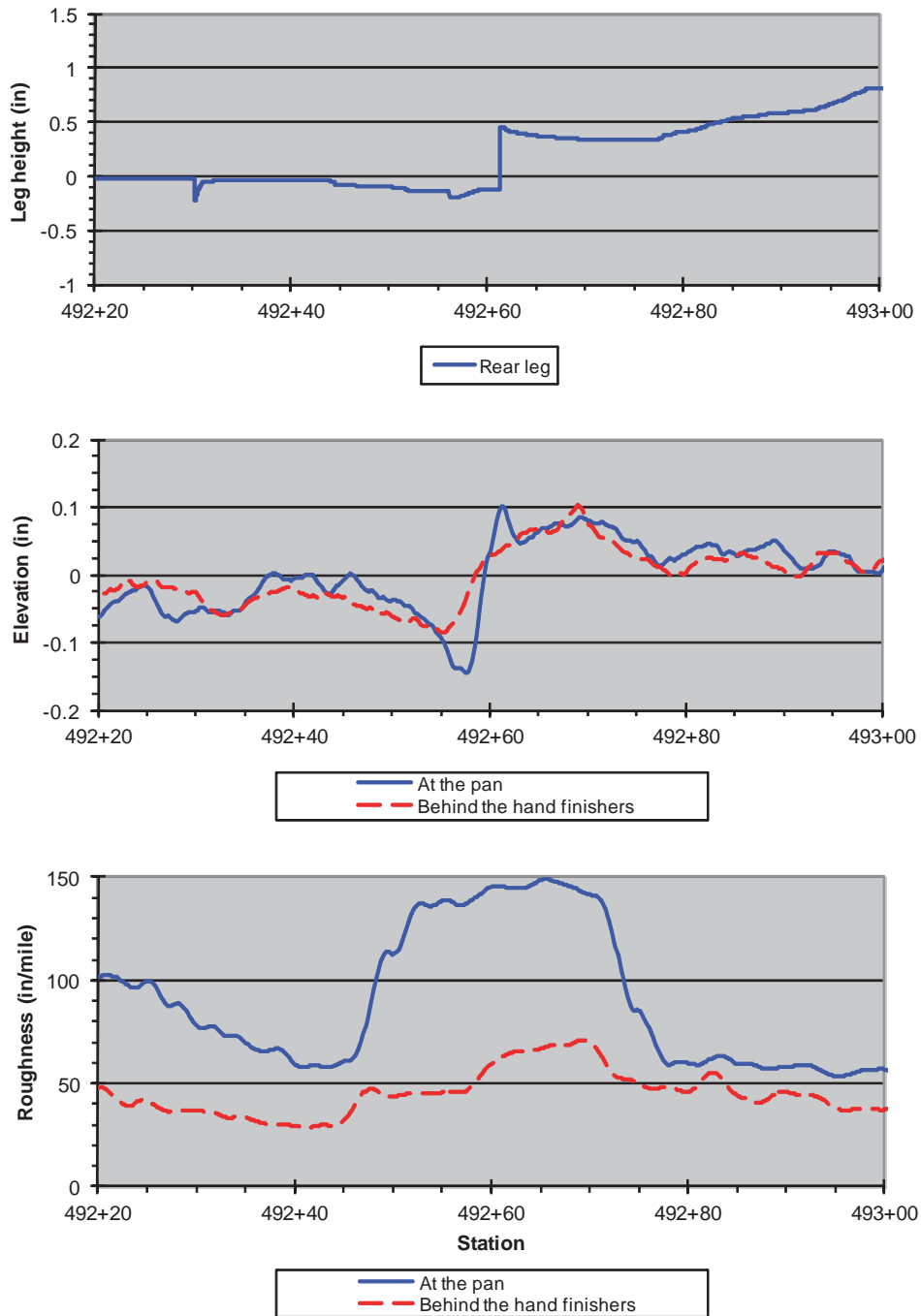
Finally, the lower graph of Figure 2.30 shows the resulting roughness calculated from the profiles. The graph shows an increase in local roughness (IRI) to 150 in./mi directly after the finishing pan. Again, the hand-finishing operation improves smoothness by reducing the roughness to about 70 in./mi.

### Reinforcement Ripple

Modern CRCP construction contains ample reinforcement to prevent cracks from opening wide enough to compromise load transfer. Both longitudinal and transverse reinforcement are used. As shown in Figure 2.31, the nominal reinforcement pattern for this project included No. 6 size longitudinal bars spaced at 5 in. on-center and No. 4 transverse bars at 36-in. centers. Figure 2.32 illustrates the reinforcing steel as placed on this project, before placement of the concrete.

Most people with CRC paving experience have encountered so-called “reinforcement ripple” on projects from time to time. This construction artifact is manifested by a repeating short-wavelength profile characteristic with the same spatial frequency as that of the transverse reinforcement. In most instances, the amplitude of this artifact is not significant enough to adversely affect the calculated IRI but may still be perceptible to a driver given its constant frequency.

As part of the hardened concrete measurements using the SurPRO device, a repeating characteristic with a spatial frequency of 36 in. (3 ft) was readily identified in both the profile trace and in a power spectral density (PSD) analysis. These are shown in Figure 2.33 and Figure 2.34, respectively. It should be noted that this artifact is not readily identifiable in the measurements collected behind the paver, thus underscoring the caution that must be taken in using real-time traces as indicative of the final hardened profile.



**Figure 2.30. Right rear leg lift, profiles, and resulting roughness during the gun swap event.**

## Field Evaluation Results

### *Repeatability and Accuracy of Data Relative to Standard Profile-Based Reference*

Real-time profiler repeatability and accuracy were tested on a section of 2-day-old hardened pavement on Wednesday,

May 12. The measurements covered a 1,000-ft-long area of pavement from Station 493+00 through Station 503+00. Testing was performed by both real-time profilers in two tracks of interest (one in each lane) covered during wet pavement profile measurements. Details about the testing, including run logs and analysis results, are in Appendix B.



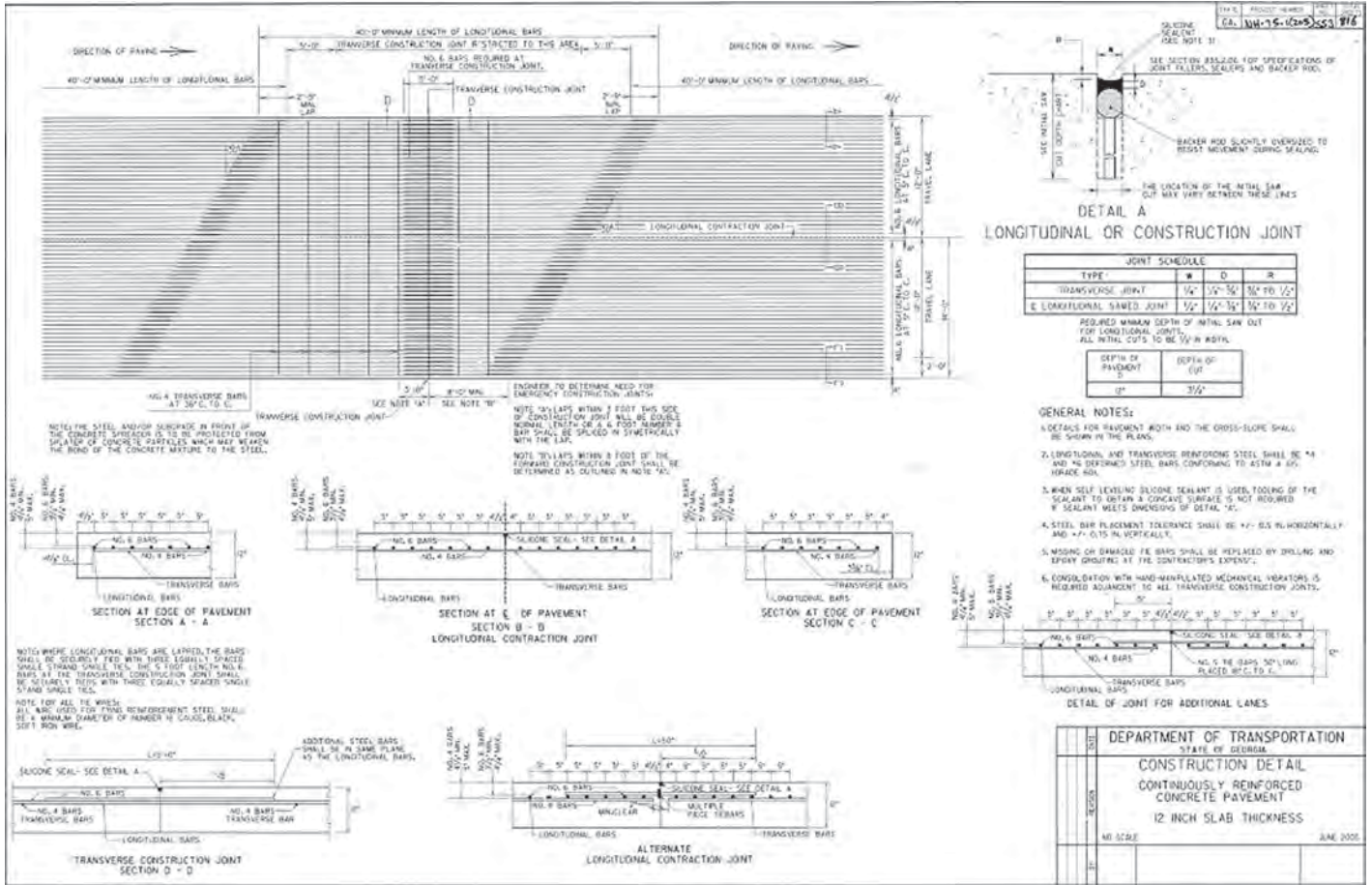


Figure 2.31. Standard detail of reinforcement used on this project.

**SURPRO 2000**

The SurPRO 2000 provided reference measurements for the experiment and was selected because it was the most efficient

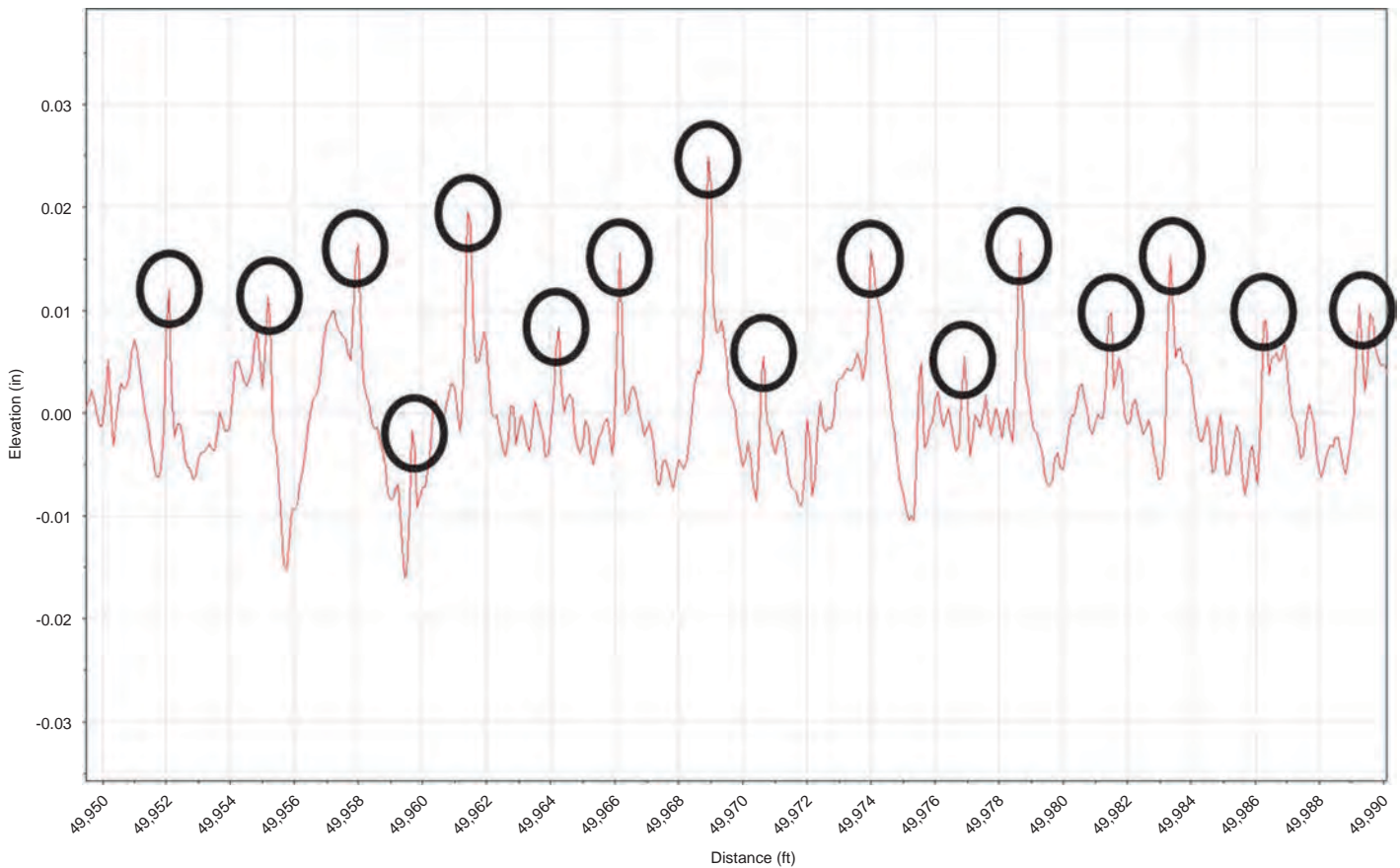


Figure 2.32. Reinforcement in place before placement of the concrete.

device available with a history of use as a reference profiler. The SurPRO 2000 appears to be a sufficient reference device for this work, because it achieved a repeatability score in the IRI waveband of about 0.93 on the test section. This value is below that expected for a reference device. However, the repeatability is high enough to facilitate a sufficient estimate of the accuracy of the real-time profilers for a judgment of their efficacy for field use. The reference profiles are also sufficiently repeatable for study of the performance of the real-time systems in various wavebands.

**INTERNATIONAL CYBERNETICS CORPORATION  
HIGH-SPEED INERTIAL PROFILER**

The two tracks of interest were also measured three times each by the Georgia DOT using an ICC high-speed inertial profiler. The high-speed unit achieved repeatability scores in the IRI waveband ranging from 0.89 to 0.95, depending on the segment. The unit also achieved an agreement score in the IRI waveband with the reference measurements in the range from 0.84 to 0.90, as well as very good agreement in spectral content through much of the range of interest and agreement



**Figure 2.33. Profile illustrating repeating “ripple.”**

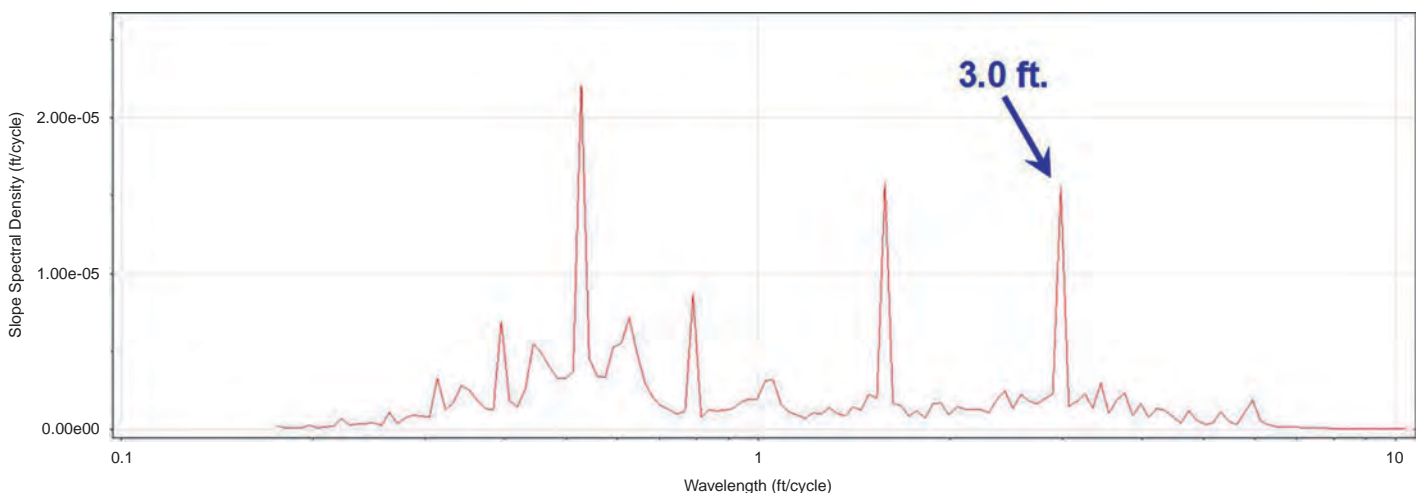
in IRI values to within 5%. In conjunction with the repeatability testing, this verifies that the SurPRO 2000 measurements did not include any major systematic errors.

#### GOMACO GSI

A GOMACO GSI measured the test section using a work bridge with two profilers: one mounted over the track of interest in the

right lane and one mounted over the track of interest in the left lane. The GSI covered the entire 1,000 ft in one pass, and repeated the measurement two more times over the second half of the section. The two units performed very differently.

The GSI mounted over the left lane achieved a repeatability score in the IRI waveband of 0.87, and an accuracy score in the IRI waveband of 0.84 to 0.87, depending on the segment. These



**Figure 2.34. Power spectral density of profile containing reinforcement ripple.**

values are not far below the expectations set within AASHTO R56-10 for profilers used in quality assurance, which are 0.92 and 0.90, respectively. In addition, the IRI values produced by the GSI in the left lane agreed with the SurPRO 2000 to within 5%. The GSI also agreed well enough with the SurPRO 2000 on the distribution of roughness along the section to qualify it as a measurement tool for seeking localized roughness.

The unit used in the left lane exhibited poor agreement to the SurPRO 2000 in the short waveband. This does not disqualify the unit's potential as a quality control tool. However, the PSD plots suggest that the disagreement may be attributable to an aggressive low-pass filter that removed more than the standard amount of short wavelength content. This filtering reduces the potential of the device for helping identify the root cause of roughness in some cases. For example, the unit did not detect the reinforcement ripple observed on this job.

The GSI mounted over the right lane exhibited a repeatability score in the IRI waveband of 0.63 and an accuracy score in the IRI waveband of 0.44 to 0.62, depending on the segment. These scores are not sufficient to qualify a profiler for construction quality control. The unit overestimated the IRI relative to the SurPRO 2000 by 18% to 39%. Disagreement in profile occurred over the entire waveband of interest, although most of the disagreement in IRI occurred at wavelengths below 10 ft.

#### AMES ENGINEERING RTP

The Ames Engineering RTP measured the test section using the RoboTex measurement system as a host vehicle. It passed over the entire section in each lane once and covered the first half of the test section in two additional passes.

The raw profiles provided by the RTP included drift that increased with the square of distance along the section. This caused the profiles to include artificial localized roughness at

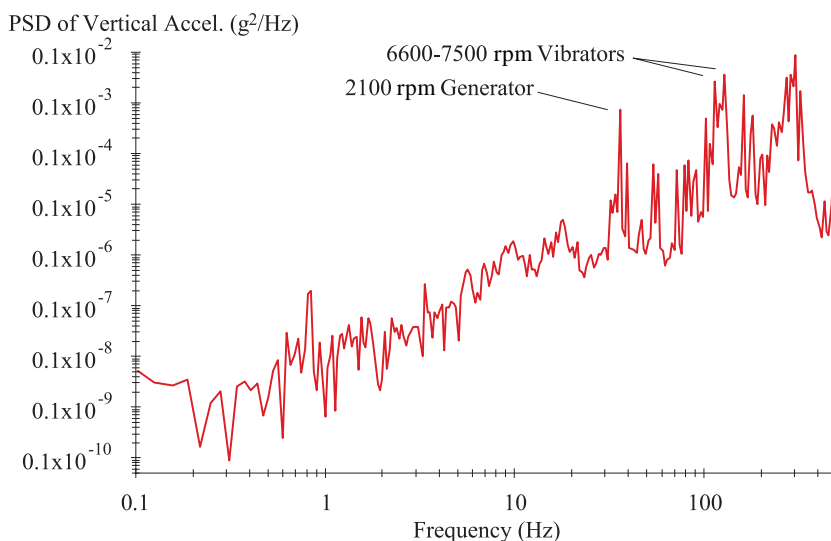
the section ends caused by filtering artifacts in the cross-correlation analysis. The RTP only made multiple passes over a section that was 500 ft long (per our instructions). Unfortunately, the combination of short runs and the large drift reduced repeatability scores in the long waveband (0.31) and the IRI waveband (0.67). Repeatability scores were 0.86 in the medium waveband and 0.89 in the short waveband.

The RTP achieved accuracy scores in the IRI waveband of 0.74 to 0.86, depending on the segment. Because the best agreement was found in the medium waveband (0.73 to 0.91), the RTP agreed well enough with the SurPRO 2000 on the distribution of roughness along the section to qualify it as a measurement tool for seeking localized roughness.

#### Sensitivity of Technologies to Vibrations Incident to Paving Operations

As described earlier in this chapter, accelerometers and IMUs were attached to the paving machine to help understand the influence of machine motion on surface profile and determine whether the quality of real-time profile measurements was affected by vibration incident to paving operations. At various times, IMUs were placed at the underside of the bridge and on the finishing pan near the locations where profilers were mounted. These provided measurements of absolute orientation and acceleration down to very low frequencies. In addition, servo-type accelerometers were placed on the finishing pan near the locations where profilers were mounted on the first day of the field experiment and moved to the mounting beams directly above the profilers on the second day of the field experiment.

Figure 2.35 shows the PSD of vertical acceleration measured at the underside of the bridge for an interval where the



**Figure 2.35.** PSD of vertical acceleration measured at the bridge.



paver was moving. Two prominent sources of vibration were the 2,100-rpm (35 Hz) generator and 6,600- to 7,500-rpm (110 to 125 Hz) vibrators. These vibrations were detected on the bridge, the pan, and the profiler support beams throughout paving operations whether or not the paving machine was moving.

Figure 2.35 also includes evidence of much weaker vibration at a frequency of about 0.8 Hz. This is most likely vibration associated with the structural resonance of the transverse beam on the paving machine and all the hardware it supports. This peak did not always appear at exactly the same frequency and most likely migrated because of changes in the amount of weight carried by the paving machine relative to the weight supported under the finishing pan.

The servo-type accelerometer measurements revealed vertical vibration at a frequency of about 25 Hz on an Ames Engineering RTP support beam that was not present on the finishing pan near the profiler mount and vibration at a frequency of about 13 Hz on the GOMACO GSI support beam that was not present on the finishing pan near the profiler mount. These vibrations are most likely associated with “flap” of the free end of each profiler mounting system.

No content in the profiles was found that corresponded to the paving machine or profiler support beam vibrations described above. Because the paving machine was moving at roughly 5 ft/min, even vibration with a frequency equal to 1 Hz would correspond to much less than a foot of distance along the profile. As such, both profilers would eliminate errors from these sources by virtue of their inherent low-pass filtering. In addition, no evidence could be found that the vibration pulses from the tie bar inserter caused any disturbance on the measured profiles. See Figure 2.25 for an example of this vibration source.

### ***Timeliness and Delivery Method of Reporting***

#### ***AMES ENGINEERING RTP***

The Ames Engineering RTP wirelessly broadcasts profile sensor data and Global Positioning System (GPS) readings from a hub on the paver for storage and potential real-time viewing and analysis on one or more laptops nearby. The Ames Engineering crew proposed that the profiler would typically broadcast to a rugged laptop mounted at a convenient location on the paver. Although this mode of operation was not demonstrated on the project, Ames Engineering did often monitor the profiling system using a laptop either at the top of the paving machine or in a vehicle nearby. Real-time monitoring was done using custom software, discussed below, that is able to process profiles in real time as well as postprocess previously collected data. Note that significant improvements in this area were accomplished later during Phase 3 of this project and are described in Chapter 3. Each profiler beam is fitted with a

warning light that be programmed to indicate that a sensor is out of range or if the IRI has exceeded a given limit.

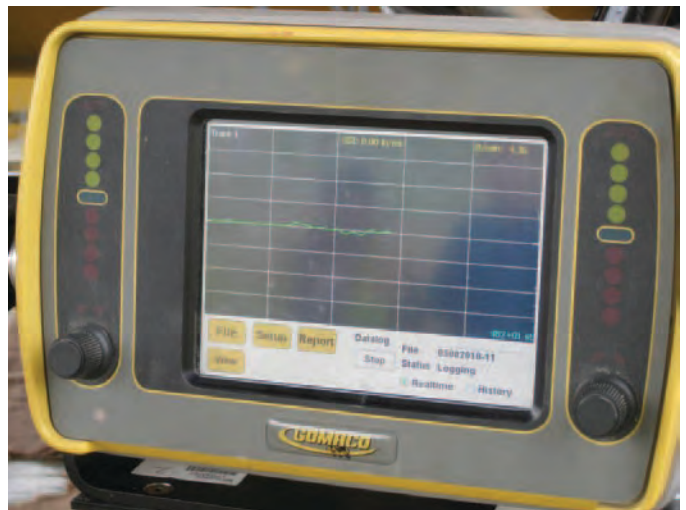
#### ***GOMACO GSI***

The GOMACO GSI includes a rugged touch-screen display, shown in Figure 2.36, for control of the profiler and display of real-time profile data and analysis results. When the GSI is mounted to the paver, the display is located at eye level at the side of the paving machine. On the I-75 reconstruction job, the contractor used a GOMACO paving machine, so a mount for the GSI display was present. When the profilers are mounted to a work bridge, as shown in Figure 2.16, the display is mounted beside the seated operator.

The real-time display typically shows one or two traces with common horizontal scaling, expressed as station. The user may select horizontal and vertical scaling and which profiles to examine (up to eight). For each trace, the user may select display of elevation profile with the trend removed, raw elevation profile, or simulated California profilograph trace. The live display also shows paver speed in ft/min and a “GSI number” for each trace. The GSI number is the IRI value averaged over a short segment of road terminating the position of the profiler. But although the GSI number is conceptually the same as a short interval report of the IRI, the unique name helps avoid confusion during wet pavement operation because the user should not expect the roughness of the surface to remain the same through other stages of the paving process.

The GSI also shows the speed of the unit in ft/min. While the profilers are running, the user can switch to a screen with tabular output that either shows an interval report of PI with adjustable parameters, IRI with a user-selected segment length, or a bump history for a selected trace.

Other user options include (1) the ability to zoom vertically and horizontally in the main display; (2) entry of event



**Figure 2.36. GSI real-time display.**

markers with a dialog box, initiated with a “double touch” on the pertinent point long the displayed trace; and (3) live adjustment of station end points. The user may also step through the history of data collected while the profiler is still operating.

The real-time display also provides menu options for control of profiler operation, including diagnostics used during daily start-up procedures to ensure that the sensors are functioning, and a setup screen that identifies the position of each profiler beam.

On the I-75 reconstruction job, the GSI display captured the attention of several members of the paving crew, DOT project supervisors, and the research team. This was due in part to the convenient placement of the display unit but also to the intuitive nature of the display, which included a plot with consistent scaling and an easily accessible roughness value. Several people at the site, including the project engineer, the paving superintendent, and some of the finishing crew, developed a habit of checking the display to monitor their progress at regular intervals and looked every time they walked by.

The crew paid particular attention to the display after an incident in which the paver operator had modified his approach to

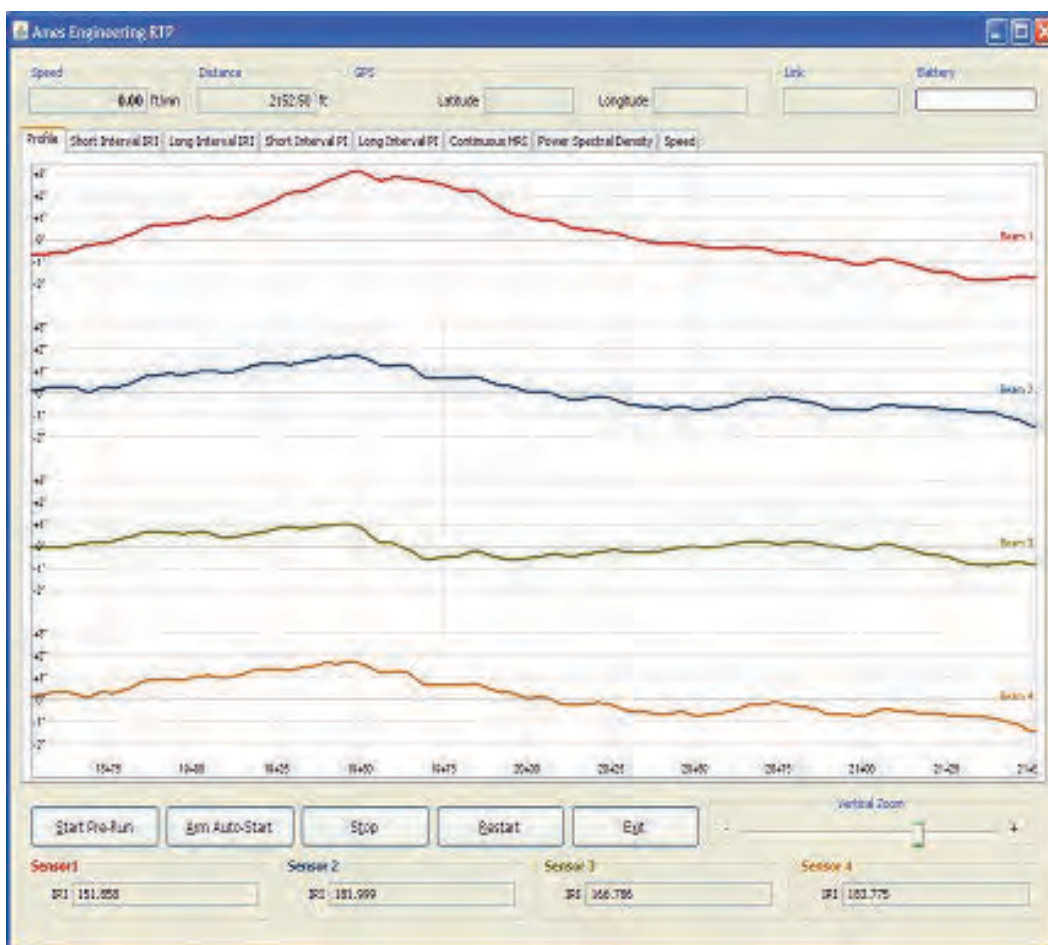
operating the strike-off plates to help improve smoothness. For the hour or so after that adjustment, the crew treated the GSI number as if it were a score at a sporting event.

### ***Availability and Adequacy of Data Processing Software***

The GOMACO GSI readily produced data in a format readable by ProVAL (i.e., ERD files) and the Ames Engineering crew was able to provide ERD files soon after they were requested. Both devices inherit all of the data processing capability of the ProVAL software so long as a Windows-based desktop or laptop is available to run it. Each device also included companion software capable of conducting real-time data analysis and reviewing previously collected data via profile plots and a variety of analyses, which are described in this chapter.

#### ***AMES ENGINEERING RTP***

Figure 2.37 provides a screen capture of the Ames Engineering RTP operating in a postprocessing mode. (This screen



**Figure 2.37.** Ames Engineering RTP analysis software.

capture was not demonstrated to the research team as a real-time function during Phase 2.) The figure shows a set of four elevation profile plots versus station. Other plots that are available are as follows:

1. A continuous roughness profile (i.e., IRI versus distance) with a short (and adjustable) interval;
2. A continuous roughness profile with a long (and adjustable) interval;
3. Short and long interval plots of simulated California profilograph PI;
4. A continuous report of the half-car roughness index (HRI) with an adjustable interval;
5. PSD plots; and
6. A plot of speed versus distance.

The continuous roughness profile plots and PI plots include a companion elevation profile plot with the same horizontal scaling.

This screen also lists the current speed and distance traveled by the profiler, the GPS coordinates, and the IRI for the most recent 528 ft covered by each unit, regardless of the type of plot that is displayed. The software that was demonstrated at the site also included a tab for producing tabulated values of IRI and PI at regular intervals and a listing of bumps. That tab is not present in the screen capture provided for Figure 2.37.

#### *GOMACO GSI*

The real-time software described in the preceding section on timeliness and delivery method of reporting also operates offline on a laptop computer. The user may load previously collected data and apply all of the analyses that were available in real time.

## **Phase 2 Recommendations for Technology Refinement**

### *Profile Measurement Quality*

Both real-time devices demonstrated adequate performance for construction quality control on portions of the hardened pavement measurement section. For purposes of this study, adequate means the following:

1. Reasonable agreement scores in comparisons to the reference profiles;
2. Ability to provide a relative estimate of roughness; and
3. Ability to recognize areas where roughness accumulates the most aggressively (i.e., localized roughness).

By using this definition, the team verified the efficacy of each device for real-time smoothness quality control.

Unfortunately, both devices also demonstrated poor agreement to the reference profiles over other parts of the hardened pavement measurement section. This was true of one of the two GSI units tested because of a high level of short wavelength noise. This was also true of the RTP in a case that seemed to be caused by a problem with the program that assembles the profiles. In both cases, a robust system of error checking and shake-down procedures may have alerted a profiler operator of a problem with the system. The development of these procedures would provide the immediate and long-term benefit to current and eventual users of these units with modest effort and a small effect on the operational and equipment cost.

The valid waveband captured by either system was limited at the short wavelength end by device geometry and limited at the long wavelength end by the sensitivity and noise levels in the sensors. Both devices provide valid profile through a large portion of the most critical waveband for roughness measurement in terms of PI, IRI, and localized roughness. However, neither is able to measure the entire waveband of interest for the IRI to qualify as a quality assurance device for calculation of pay adjustments for smoothness. That is, neither device would pass AASHTO R56-10. Extending the valid waveband of these devices would either require investment in potentially prohibitively expensive sensors or redesign of the layout of the profiles and incorporation of at least one other sensor per unit.

### *Operational Issues*

The GOMACO GSI demonstrated a simple and intuitive operational system with a powerful real-time display. Furthermore, the visible placement of the display module helped raise the visibility of smoothness as an issue to be considered while paving.

The Ames Engineering RTP software also offered several relevant real-time display options, but during Phase 2, the system itself had not matured to the point where a polished, highly visible display was demonstrated. Enhancements in this area were later accomplished and are described in Chapter 3.

### *Data Processing Software*

Given the prevalence of the ProVAL software, development of analysis capabilities should be confined to those items that would serve paving crews best in real time and in streamlining of data file export. For either real-time device, an expert system that seeks threats to smoothness with common characteristics may add value for users without much profile analysis experience. The limits of the profilers at the short wavelength end of the spectrum would prevent such a system from providing a comprehensive coverage of all possible paving problems. In this study, reinforcement ripple would have



gone undetected by the research team if not for the reference profile measurements. In lieu of a comprehensive expert system, the analysis for the field evaluation and field demonstrations documented throughout this report, along with the guidelines summarized in Chapter 3, provides examples of paving problems and how they may be detected with these systems as a starting point.

## Technology Demonstrations

As described earlier in this chapter, the field evaluation in Phase 2 concluded that both the GOMACO GSI and the Ames Engineering RTP are viable technologies to evaluate smoothness in real time. It was therefore recommended that both technologies be a part of the field demonstrations conducted under Phase 3.

This section presents summaries for the four demonstration sites. The GSI was demonstrated in Arkansas and Michigan, and the Ames Engineering RTP was demonstrated in Texas, Michigan, and New York. Each field demonstration involved monitoring of the construction operation while conducting the real-time smoothness measurements. Each site included testing on the hardened concrete with the device under evaluation and, based on availability, the contractor's (or host agency) quality control and/or quality assurance profiling device and/or a reference profiler. At two sites, Michigan and New York, supplementary vibration measurements were also taken at select locations deemed relevant to the operation of the real-time profilers.

One of the field demonstrations (Texas) was conducted on a CRCP project and the remaining three field demonstrations were conducted on jointed plain concrete pavements (JPCP). These field demonstrations were completed from April 2011 through August 2011. The identification of these projects was the result of telephone conversations between the research team and the respective concrete paving contractors. As before, stipends were provided to each vendor to offset reasonable costs associated with the demonstration.

### Techniques for Technology Demonstrations: Data Reduction and Analysis

#### *Real-Time Profile Analysis*

The process of visualizing and analyzing pavement profiles has been simplified in recent years using tools such as the ProVAL software. One significant advantage to this software is the ability to read profiles from virtually all major manufacturers, including the real-time profilers that were evaluated in this project.

The figures in Appendices D through F illustrate the results of the data reduction and analysis for the demonstration

sites. The following visualization and analysis techniques were used:

1. *ProVAL Viewer*. This feature allows the user to plot elevation versus distance. Quite often, diagnostics can be made in this way, particularly if multiple profiles are being compared. The user should look for trends in the profile, along with rapid changes in elevation. To make the most use of this feature, profiles should be filtered using a high-pass Butterworth filter with a cutoff frequency of 100 to 300 ft.
2. *Profilograph Simulation Analysis*. Although many states have made advancements toward using the IRI as a quality metric, some continue to use PIs. ProVAL can be used to analyze the real-time (and other) profiles in such a way as to simulate the results of a profilograph. In this way, the "traces" from the various profilers can be compared. Localized roughness can be identified via scallops on these traces, and the overall PIs calculated based on various blanking bands (commonly used values include 0.0 and 0.2 in.).
3. *Continuous Ride Quality (IRI) Analysis*. This analysis is more relevant to ride quality (as compared to the profilograph analysis). ProVAL can be used to process the profiles in such a way as to provide a continuous trace of IRI. With this, roughness in the vicinity of any given location can be quantified in a relevant manner. During this analysis, various "segment lengths" can be used, but often those in the range of 100 to 500 ft will yield helpful results. Too small a length will make a visual interpretation of the results more difficult, and too long a length will make the identification of localized roughness more difficult.
4. *Power Spectral Density Analysis*. This more advanced analysis can be particularly useful in understanding ongoing "systematic" elements of the profile. Many of the construction artifacts discussed in this report are ones that occur on a repeated basis throughout the paving process. PSD analysis allows these artifacts to be efficiently identified. Furthermore, when comparing the PSD traces from different profilers or profiler positions, further interpretation can be made about the source of the repeating feature.
5. *Cross-Correlation Analysis*. This technique can yield important benefits when analyzing real-time profiler data. First, it can be used to synchronize profiles collected by various types of equipment. Second, the similarity between profiles can be quantified using this technique through the reporting of a correlation coefficient. As this value approaches zero, there is less and less similarity between the profiles being compared. As the value approaches 1, the profiles are deemed similar; the higher the number, the more similar they are. Specific thresholds for comparing profiles can be found elsewhere (most notably, the critical profiler accuracy report prepared by Karamihas [2005]).

The specifics about how these analyses can be performed in ProVAL are not included here, because they can be found in the supporting documentation for the ProVAL software. ProVAL was developed for the FHWA and through a Pooled Fund project and is distributed free of charge at [www.RoadProfile.com](http://www.RoadProfile.com).

### ***Vibration Measurements Analysis***

At two sites, Michigan and New York, vibration measurements were taken at select locations deemed relevant to the operation of the real-time profilers. More specifically, measurements were collected with the intent to identify vibration frequencies that could contribute to the measurements being collected by the profilers. With this information, it is possible to derive a better understanding of the response of the profilers themselves, because the vibrations can result in measurement artifacts. Although it was beyond the scope of this demonstration phase to conduct a robust analysis of the data collected, a summary of the measurements is provided here.

In all instances, measurements were collected using a MicroStrain Inertia-Link sensor. This sensor can measure accelerations along three orthogonal axes ( $x$ ,  $y$ ,  $z$ ), as well as rotational velocities about these same axes.

### **Arkansas**

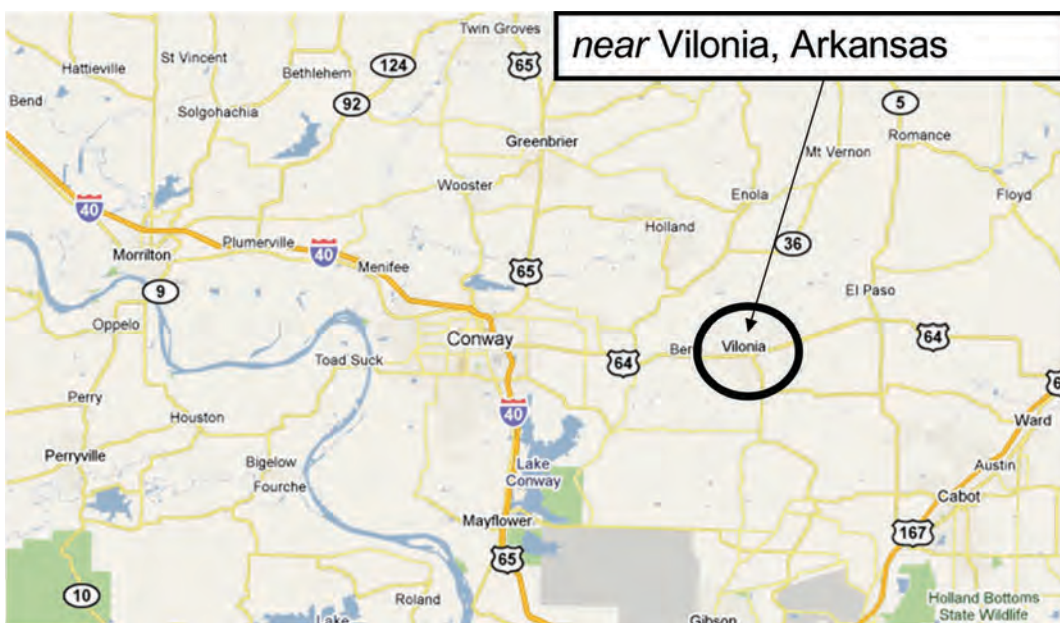
The first technology demonstration was conducted with the GOMACO GSI the week of May 9, 2011, near Vilonia,

Arkansas (see Figures 2.38 and 2.39). GOMACO used two independent GSI units for this demonstration. The first unit was attached to the paver, and the second unit was a stand-alone setup mounted onto the GSI machine that was located behind the texture/cure cart.

In addition to the profile measurements in real-time, a 1,000-ft section paved during the second day (May 10) of the evaluation was retested during the last day (May 11), at which time the JPCP surface was strong enough to support light traffic. Repeat measurements were conducted with the contractor's lightweight profiler—Arkansas Highway and Transportation Department (AHTD) lightweight profiler—and the stand-alone GSI machine. Follow-up measurements with a high-speed profiler (AHTD ARAN system) were conducted later on June 2. All readings matched the track lines profiled in real time during the first day (May 10). The real-time and hardened surface profiles were compared to evaluate accuracy, reproducibility, and repeatability, and the results are summarized in Appendix D.

### ***Test Section Description***

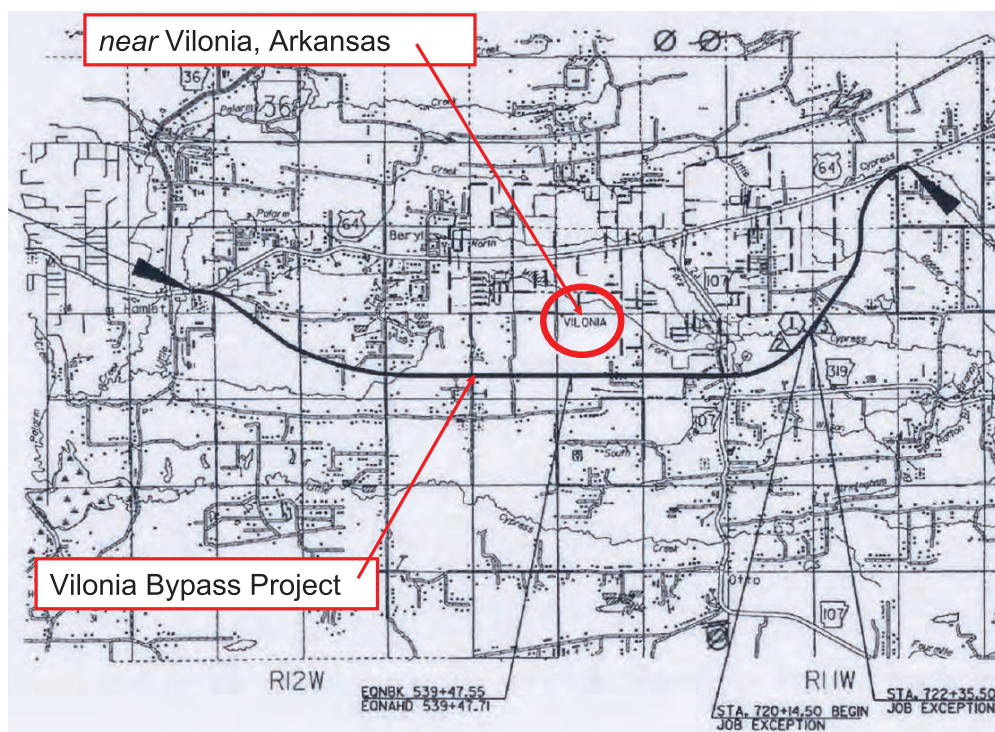
The demonstration took place at the Vilonia Bypass project by AHTD, in Faulkner County, Arkansas (Project NH-0023[40]). The general contractor of the project was Interstate Highway Construction (IHC). It was anticipated that the bypass will experience initial average daily traffic (ADT) of 7,000 vehicles (16% of which will be trucks) based on ADT data for 2010.



© 2011 Google, Map Data.

**Figure 2.38. Phase 3 technology demonstration project in Arkansas.**





**Figure 2.39. Phase 3 technology demonstration project limits in Arkansas.**

The project consisted of new alignment construction of 10.142 mi with JPCP with transverse joints every 15 ft measured from the center of one joint to the center of the next joint (i.e., center-to-center or *c/c*). The transverse joints included 1.25-in. dowel bars placed every 12 in. *c/c*. Longitudinal joints between lanes were held together with No. 5 steel tie bars placed every 30 in. *c/c*. Appendix G presents a typical section and the information provided by the contractor for concrete mix design, quality control, and quality assurance tests.

### **Paving Operation**

Concrete was produced from a central mix batch plant located near the midpoint of the project. The concrete mixture was transported in nonagitating dump trucks and deposited on the grade in front of the slipform paver. Typical haul times from the plant site to the paving operation were approximately 15 min.

Consolidation and initial finishing of the pavement were accomplished with a Guntert & Zimmerman 850 slipform paver (see Figure 2.40). Internal hydraulic vibrators on the paver were placed at approximately 6 in. from the pavement edge and then subsequently spaced at approximately 18 in. *c/c* across the interior of the pavement. A dowel bar inserter was used to place the dowels in the transverse joints.

Hand finishing of the pavement behind the paver was performed using straightedges 12 ft wide, which filled in any surface voids. Smoothness was checked with a 20-ft-wide straightedge (see Figure 2.41). When surface corrections were necessary, they were made with the smaller straightedge and final finishing was then performed with the larger straightedge; a combination of other hand-finishing tools were used for final finishing of the pavement edges. A burlap drag was



**Figure 2.40. Guntert & Zimmerman 850 slipform paver.**



**Figure 2.41. Straightedge used to identify bumps and dips.**

used behind the hand finishers to provide additional texture to the pavement surface.

A transverse tined texture with uniform, 0.75-in. spacing was applied to the pavement surface. This operation typically followed approximately 60 min behind the paving operations; thus curing compound was applied to the pavement surface before any deleterious surface evaporation could occur.

### ***Analysis of Events and Observations in Field Data***

Using the cross-correlation analysis feature of ProVAL, each of the profiler runs could be aligned, and the data within the “golden section” parsed for further analysis. The figures in Appendix D illustrate the results of the various analysis techniques previously described.

In general, the bridge-mounted profiler appears to be trending in a similar fashion to the profiles on the hardened concrete. The paver-mounted profiler, however, appears to be contaminated by other sources, with the most notable being the excessive vibration induced by the oscillating correcting beam (OCB) on the back of the IHC paver. Some additional construction artifacts could be identified in the data from Arkansas, as described in the following sections.

#### ***TRACK LINE DEVIATION***

The real-time smoothness technology demonstration was originally scheduled for the week of April 18, 2011. Extended periods of rain caused the cancellation of this attempt. Subsequently, there were areas of saturated and unstable subgrade that forced the contractor to move the paving operation to the west end of the project where firmer subgrade conditions were present. Despite this change in location, there was



**Figure 2.42. Paver track line deviation resulting from unstable subgrade conditions.**

an isolated area of yielding subgrade in the paver track line (see Figures 2.42 and 2.43).

Localized roughness at this location (Station 357+00) was found to coincide with the change in the track line for the paver to that of a soft material (unstabilized base). Unstable tracking was observed during paving, and the profile at this location was likely affected as a result.

#### ***STRING LINE SPLICE***

One location of interest was indicated by localized roughness at Station 358+00. It was found that at this location, there was a splice in the string line, and it is possible that some survey error, or disturbance of the string line at this location, yielded



**Figure 2.43. Soft material in paver track line at location of localized roughness.**





**Figure 2.44. String line splice at location of localized roughness.**

a deviation from a smooth profile. This deviation led, in turn, to localized roughness. This splice is illustrated in Figure 2.44.

#### UNSTABLE BASE

At Station 359+00, there was an additional location demonstrating localized roughness. In comparing notes taken during construction, this area corresponds to noted failures in the pavement interlayer. Numerous last-minute repairs were made immediately in front of the concrete paving to attempt to rectify these failures; however, not all could be repaired before the paving. One such example is illustrated in Figure 2.45.

#### REAL-TIME FEEDBACK

Approximately 2 h into the technology demonstration, the contractor ceased using the larger straightedge (20 ft wide) for identifying bumps and dips and relied on the GSI for pavement smoothness feedback instead. An adjustment to the sensitivity on one of the paver's leg barrels was made. Under normal conditions, it could take up to approximately 24 h after paving before the contractor would receive any feedback on how this adjustment affected pavement smoothness. By using real-time



**Figure 2.45. Failure in HMA interlayer at location of localized roughness.**

smoothness measurements, however, the contractor reported that the effect of paver adjustments was known in 2 to 3 h.

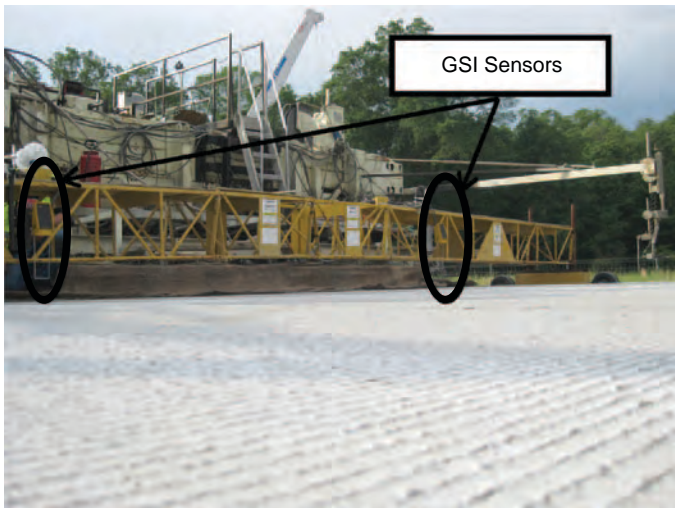
#### OSCILLATING CORRECTING BEAM AND REAL-TIME SYSTEM SETUP

The dowel bar inserter on the paver used an OCB to finish the pavement after the dowels were inserted. The OCB caused significant movement of the real-time system measurement equipment when mounted to the paver (see Figure 2.46). In an effort to minimize the effect of the OCB, the GSI equipment was mounted to a work bridge towed by the paver as shown in Figure 2.47. Although not evaluated by the research team, observations by IHC led to the conclusion that this alternative mounting arrangement performed similarly to the original paver mount setup.



**Figure 2.46. Paver-mounted GSI setup.**





**Figure 2.47.** GSI equipment mounted to a work bridge.

## Texas

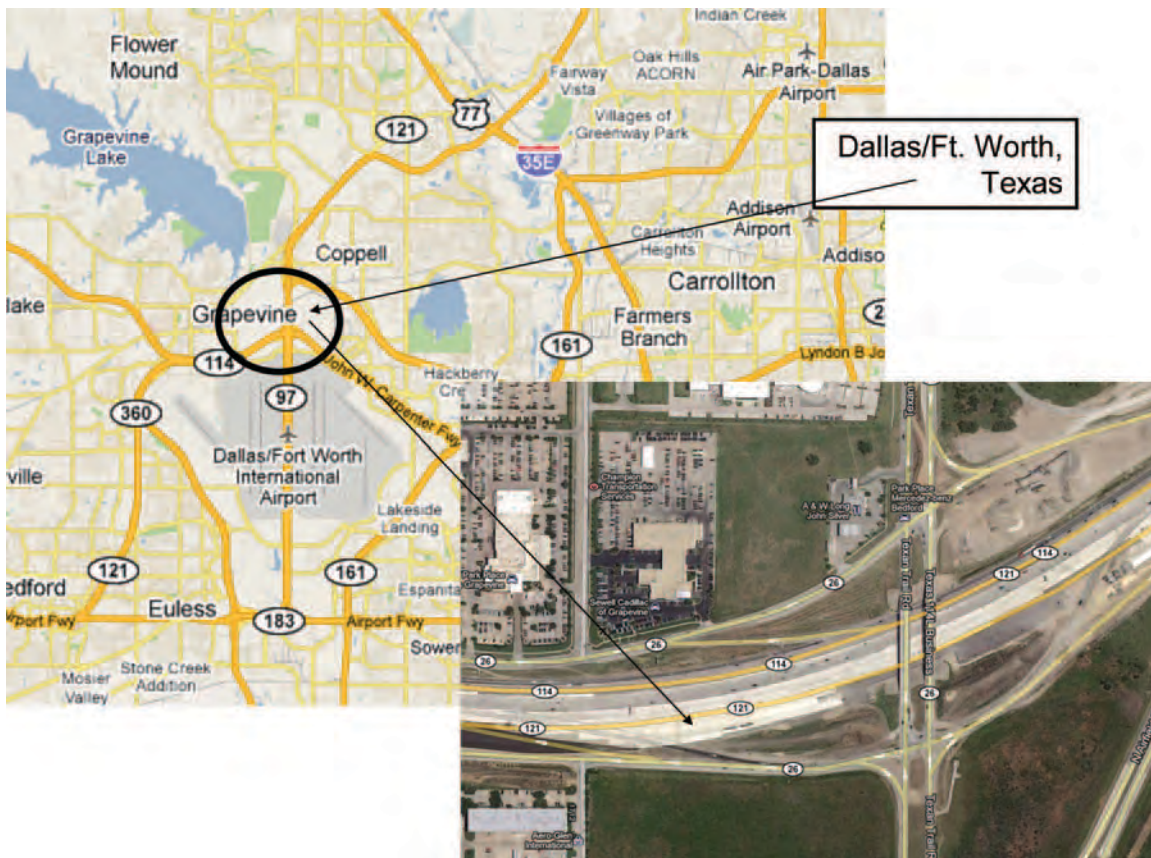
The second technology demonstration was conducted with the Ames Engineering RTP during the week of June 6, 2011, in the Dallas/Fort Worth area of Texas (see Figure 2.48). In

addition to the profile measurements in real time, a 1,000-ft section was retested during the last day (June 10), at which time the pavement surface was strong enough to support light traffic. Repeat measurements were conducted with the contractor's lightweight profiler, and the lightweight profiler was used for quality assurance.

### Test Section Description

The demonstration was conducted at the widening and reconstruction along State Highway 114 and State Highway 121 (SH-114 and SH-121) just east of Texan Trail Road. The reconstructed and widened pavement sections are part of a much larger Texas Department of Transportation Design-Build project commonly referred to as the DFW Connector project. NorthGate is the general contractor (consortium) for this project. Raw traffic data collected for 2011 report an ADT of 214,600 vehicles per day.

The project consisted of 8.4 mi of newly constructed pavement with 13-in.-thick CRCP. Reinforcement followed requirements set forth by the Texas DOT 2009 CRCP Design Standard. All bars were Grade 60, deformed steel. In the longitudinal direction, reinforcement included No. 6 bars



© 2011 Google, Map Data.

**Figure 2.48.** Phase 3 technology demonstration in Texas.



**Figure 2.49. Belt placer/spreader used for concrete placement and live bottom trailer.**

spaced at 5.5 in. *c/c*; in the transverse direction, the use of No. 5 bars spaced at 4 ft *c/c* was typical. Tie bars at longitudinal joints were No. 5 bars spaced at 48 in. *c/c*. Appendix G provides information supplied by the contractor regarding the concrete mix design, quality control, and quality assurance tests.

### **Paving Operation**

Because of hot weather conditions and heavy traffic through the project site, concrete pavement construction was performed during nighttime hours on this project. Concrete was produced from a central mix batch plant located near the midpoint of the project. The concrete mixture was transported in nonagitating live bottom trailers and spread in front of the paver using a GOMACO GHP 2800 belt placer (Figure 2.49). Typical haul times from the plant site to the paving operation were approximately 15 min.

Consolidation and initial finishing of the pavement were accomplished with a Guntert & Zimmerman 850 slipform paver using Leica stringless controls for elevation and steering. Internal hydraulic vibrators on the paver were placed at approximately 6 in. from the pavement edge and then subsequently spaced at approximately 18 in. *c/c* across the interior of the pavement. A final finisher was mounted to the rear of the paver (see Figure 2.50).

In general, hand finishing of the pavement was minimal. The concrete mixture was uniform, workable, and finished easily with few surface voids. An artificial-turf carpet drag was used before the final texture was applied to provide additional texture to the pavement surface. A transverse-tined texture with uniform, 1-in. spacing was applied to the pavement surface. This operation occurred soon enough after paving operations so that the curing compound was applied

to the pavement surface before any deleterious surface evaporation could occur.

### **Analysis of Events and Observations in Field Data**

Unfortunately, after the real-time smoothness data collected was inspected, it was determined that an electrical malfunction during the field demonstration prevented proper operation of the Ames Engineering RTP equipment. In an effort to continue demonstration and refinements of the RTP technology, Ames Engineering participated in the subsequent field demonstrations (Michigan). The original plan had been for them to participate in only one more demonstration (New York).



**Figure 2.50. Guntert & Zimmerman 850 slipform paver and final finisher.**





© 2011 Google, Map Data.

**Figure 2.51. Phase 3 technology demonstration project in Michigan.**

## Michigan

The third technology demonstration was held in Jackson County, Michigan, during the week of July 11, 2011 (see Figure 2.51). Both the GOMACO GSI and Ames Engineering RTP were demonstrated. On this project, the GSI was mounted to a towed work bridge and not the tractor-propelled GSI machine. The RTP was mounted to the same work bridge, but operating in different wheelpaths than the GSI. Because this is a demonstration project, the intent was not to compare these profilers, as was done in Phase 2.

In addition to the real-time smoothness measurements, a 1,200-ft section was retested when the JPCP surface was strong enough to support light traffic. Repeat measurements were conducted at different dates with the contractor's lightweight profiler, both real-time profilers (GSI and RTP), and the Michigan DOT SurPRO 2000 reference profiler. Readings matched the same tracks that were profiled in real time. Surface profiles (real-time and hardened concrete) were compared to evaluate accuracy, reproducibility, and repeatability. The results are summarized in Appendix E.

### Test Section Description

The demonstration took place at the I-94 reconstruction project in Jackson County, Michigan. The general contractor for this project was Interstate Highway Construction. ADT estimate for 2009 was 23,300 vehicles with 18% trucks.

The project consisted of pavement reconstruction with an 11-in.-thick JPCP with transverse joints every 14 ft c/c. The transverse joints included 1.25-in. dowel bars for load transfer. Longitudinal joints were held together with Grade 60, No. 5, deformed steel tie bars spaced at 31 in. c/c at the centerline and 41 in. c/c at the shoulders.

### Paving Operation

Concrete was produced from a central mix batch plant located near the midpoint of the project. The concrete mixture was transported in nonagitating dump trucks and trailers and deposited on the grade in front of the slipform paver. Typical haul times from the plant site to the paving operation were approximately 15 min.

Consolidation and initial finishing of the pavement were accomplished with a Guntert & Zimmerman 850 slipform paver. Internal hydraulic vibrators on the paver were placed at approximately 6 in. from the pavement edge and then subsequently spaced at approximately 18 in. c/c across the interior of the pavement. A dowel bar inserter was used to place the load transfer dowels in the transverse joints.

Straightedges 12 ft wide were used to hand finish the pavement behind the paver. A combination of tools was used for final finishing of the pavement edges. Some texture was applied to the surface using a burlap drag. A longitudinal tined texture with 0.75-in., uniform spacing was applied to the pavement

surface followed by application of a curing compound to the pavement surface before any deleterious surface evaporation could occur.

### ***Analysis of Events and Observations in Field Data***

Using the cross-correlation analysis feature of ProVAL, each of the profiler runs could be aligned, and the data within the golden section could be parsed for further analysis. The results of the data processing for Michigan can be found in Appendix E.

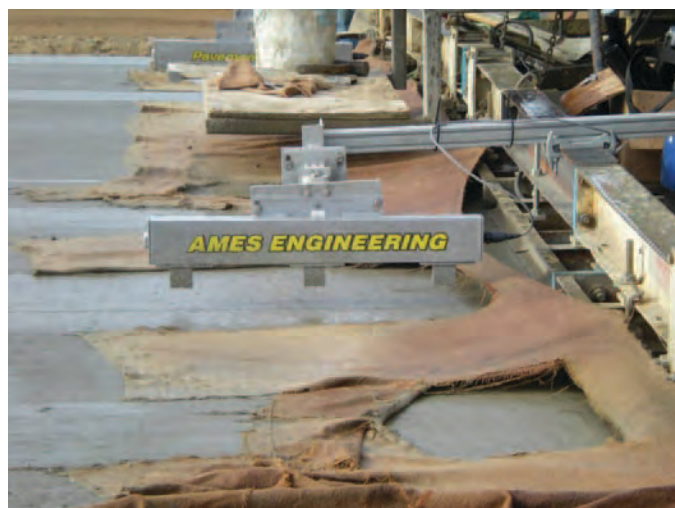
There was little to report in terms of specific construction events that led to artifacts that could be observed in the pavement profiles for this site. As was done by the contractor in Arkansas, the Michigan contractor used the real-time profiling equipment to monitor multiple changes made to the sensitivity of the paver's leg barrels. This allowed the contractor to realize the effect of paver adjustments on smoothness within 2 to 3 h after placement.

### ***Real-Time Profiler Mounting***

On the basis of the experience from the Arkansas technology demonstration where the oscillating correcting beam's vibrations influenced real-time smoothness measurements, the GOMACO GSI and Ames Engineering RTP equipment were mounted to a work bridge towed by the paver (Figure 2.52). At the contractor's request, Ames Engineering stayed on site for an additional day and mounted its equipment to the back of the paver (see Figure 2.53). This mounting appeared to perform well. Data from measurements taken on July 14, 2011, were provided to the research team.



**Figure 2.52. GOMACO GSI and Ames Engineering RTP mounted to a work bridge towed by the paver.**



**Figure 2.53. Ames Engineering RTP mounted to the rear of the paver.**

The dowel bar inserter on the paver used an OCB to finish the pavement after the dowels had been inserted. Contrary to the vibrations observed at the Arkansas technology demonstration, it appeared that the OCB on this paver did not cause excessive vibrations.

### ***Vibration Measurements Analysis***

At this site, six measurement positions were selected for vibration measurements. Because both the Ames Engineering RTP and the GOMACO GSI systems were evaluated at this site, measurements were taken that are relevant to each of the two systems. Table 2.2 summarizes the location and operating conditions for each of the six samples collected using the Inertia-Link sensor.

The ProVAL software was used to view and analyze the Inertia-Link data. The data were transformed into ERD files with a step size in feet equal to the sample interval in seconds (0.01 s). In other words, to interpret the results, “feet” should be interpreted as seconds. The amplitudes are accelerations in units of  $g$ . In this section, accelerations oriented in the vertical direction ( $z$ ) are of most significance, and these values are nominally centered about  $-1.0 g$  because of the Earth's gravitational effect.

Figure 2.57 illustrates the temporal signal of a typical sample of the data (approximately 8 to 9 s in duration) collected along the beam supporting the finishing pan. In this figure, it can be seen that the signals collected at the two locations are similar in nature.

Figure 2.58 shows a sample of similar duration, but for the sensors mounted to the OCB. The signal with the lowest amplitudes was collected while the OCB (and paver) were



**Table 2.2. Summary of Inertia-Link Sensor Locations and Relevant Profiler for Michigan**

| Measurement Sequence | Mount   | Distance from Left Edge (in.) | Relevant Profiler    |
|----------------------|---|-------------------------------|----------------------|
| MI-1                 | Finishing pan (support beam). See Figure 2.54               | 102                           | Ames Engineering RTP |
| MI-2                 | Finishing pan (support beam). See Figure 2.54               | 162                           | GOMACO GSI           |
| MI-3                 | Oscillating correcting beam—OCB in motion. See Figure 2.55  | 102                           | na <sup>a</sup>      |
| MI-4                 | Oscillating correcting beam—OCB stationary. See Figure 2.55 | 102                           | na <sup>a</sup>      |
| MI-5                 | Profiler bridge. See Figure 2.56                            | 176                           | GOMACO GSI           |
| MI-6                 | Profiler bridge. See Figure 2.56                            | 108                           | Ames Engineering RTP |

<sup>a</sup> These are “na” (not applicable) because the OCB would not be a candidate mount location for a real-time profiler.



**Figure 2.54. Inertia-Link mounted to the beam fixed to the finishing pan.**



**Figure 2.55. Inertia-Link mounted to the OCB.**

stationary. The same plot contains the measured accelerations with the OCB switched on. As can be expected, there was a significant difference in the amplitudes because of the motion of the OCB.

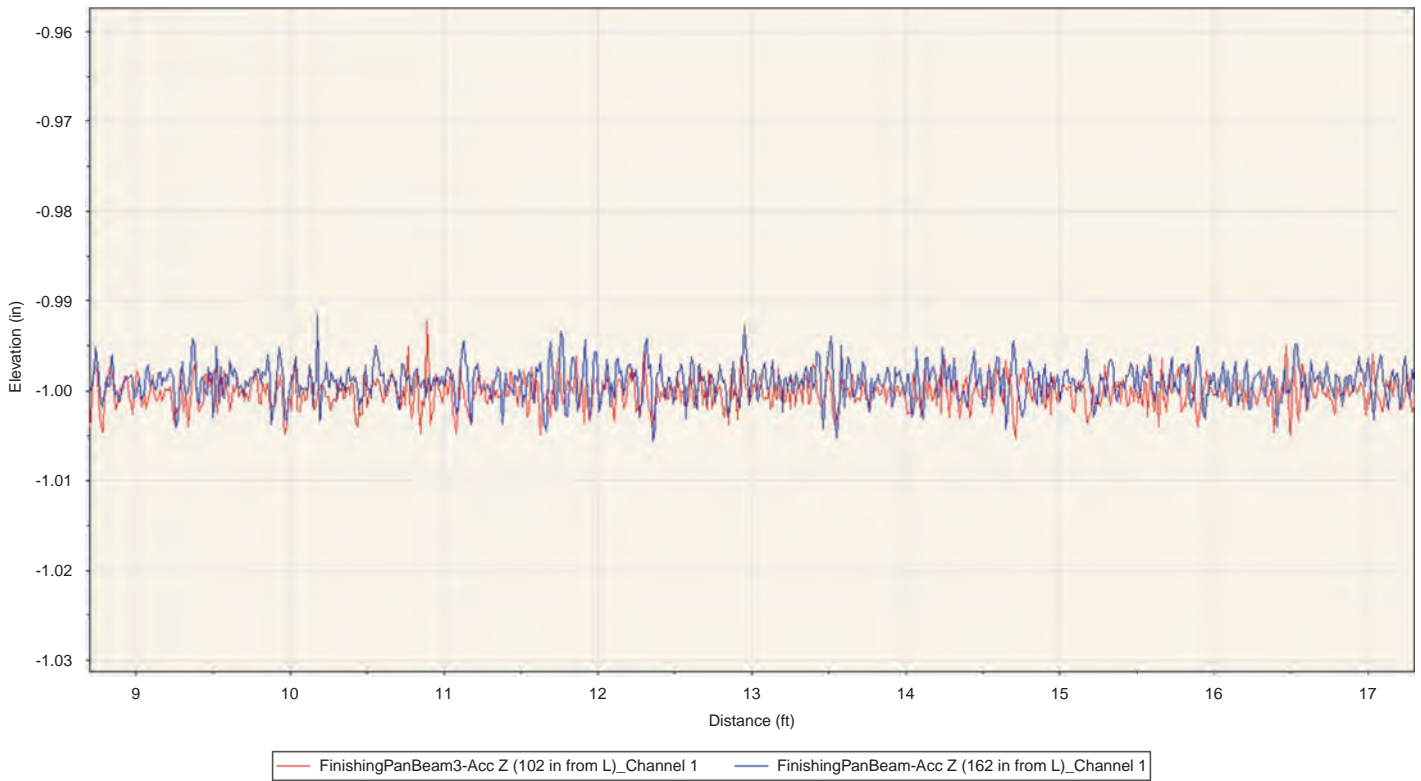
Figure 2.59 includes vertical accelerations along the work bridge supporting the real-time profilers. Signals were collected at two different positions, and differences between the two positions can be noted. Because the work bridge can be idealized as a simply supported beam, varied amplitudes along its length are to be expected.

Analyzing the frequency content of the signals is very straightforward using the ProVAL PSD analysis. Figure 2.60 illustrates the PSD of the two samples collected along the finishing beam, which are the same signals shown in Figure 2.57. As can be seen from the frequency analysis, there are distinct frequencies that are present in the signal. Most of these peaks fall within the 4- to 15-Hz range and are identical for the

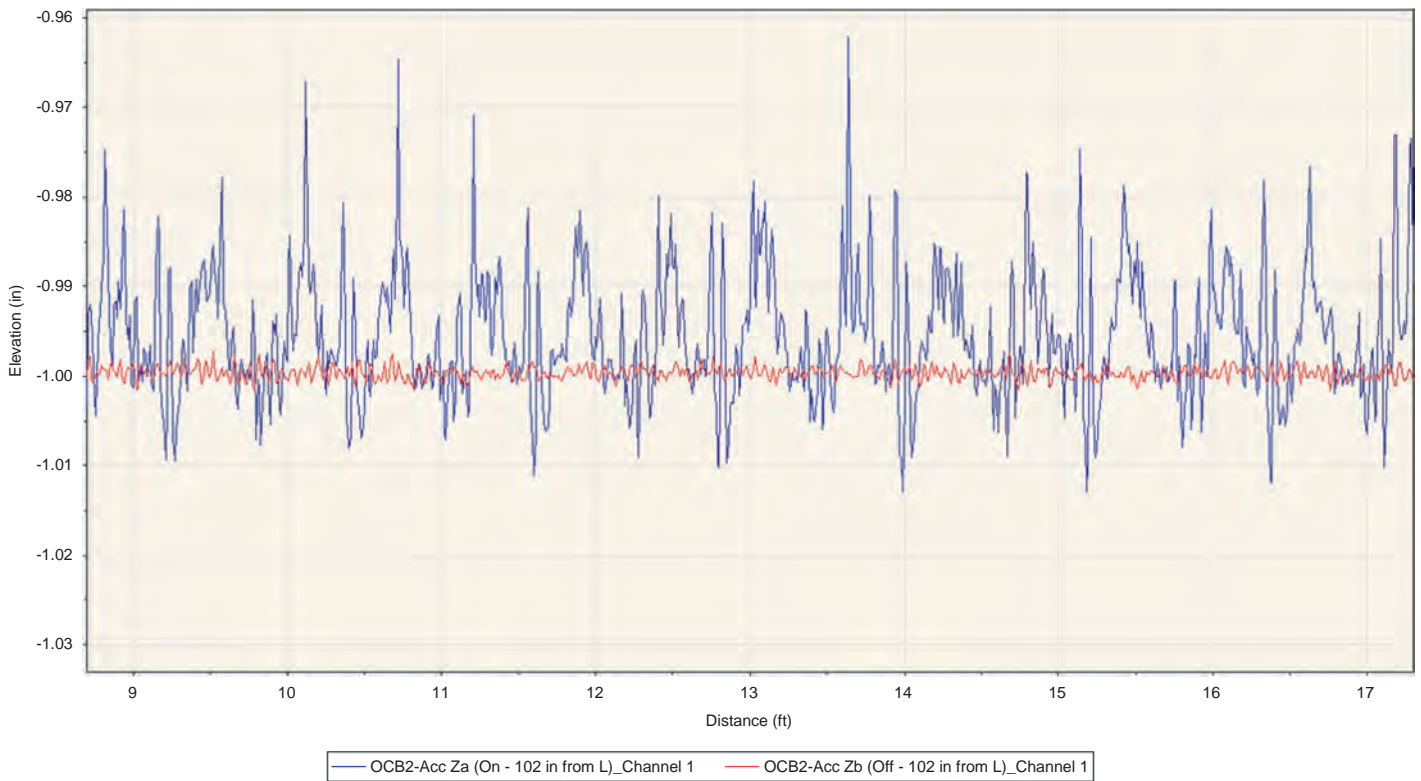


**Figure 2.56. Inertia-Link mounted to the profiler bridge.**

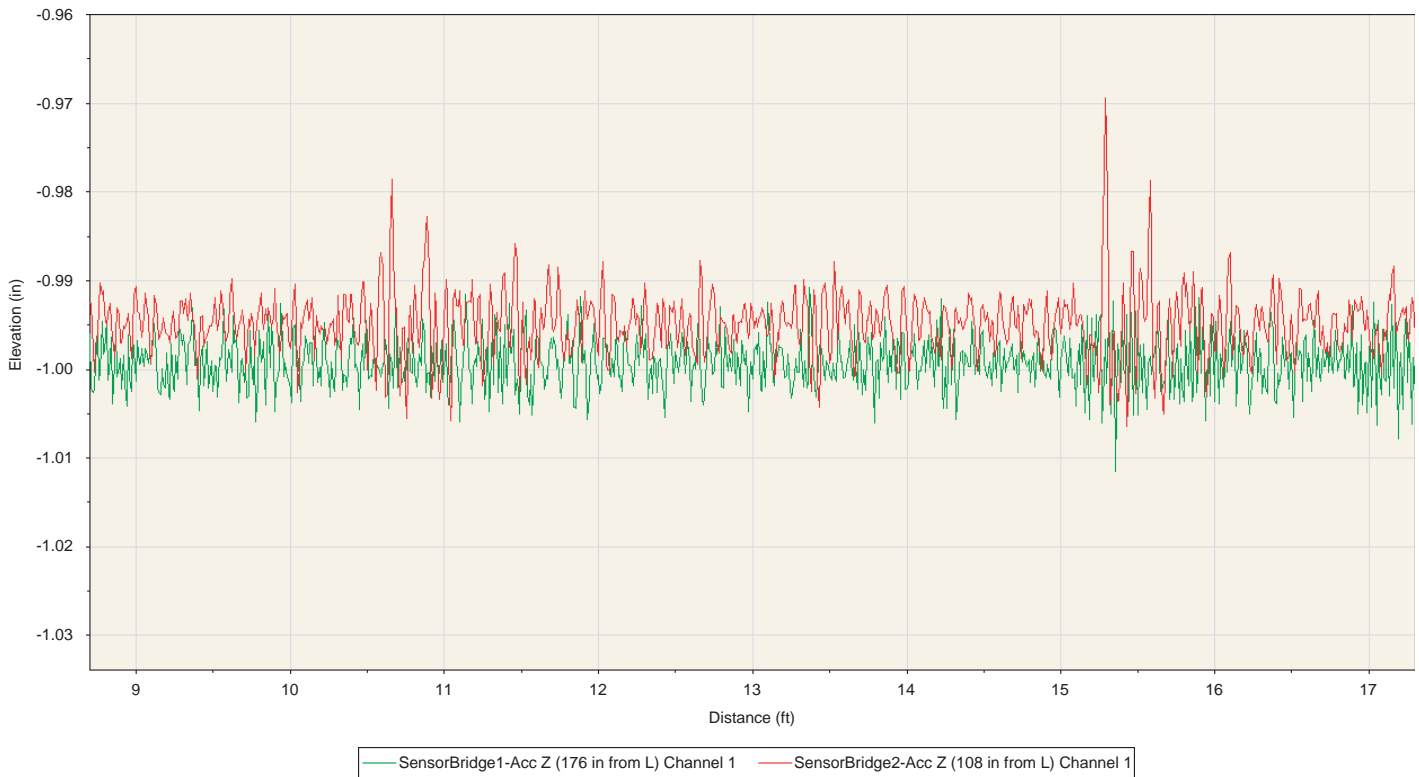




**Figure 2.57. Sample of vertical acceleration data collected at two different locations along finishing pan beam (MI-1 and MI-2).**



**Figure 2.58. Sample of vertical acceleration data collected on the OCB, during operation (MI-3) and when stationary (MI-4).**



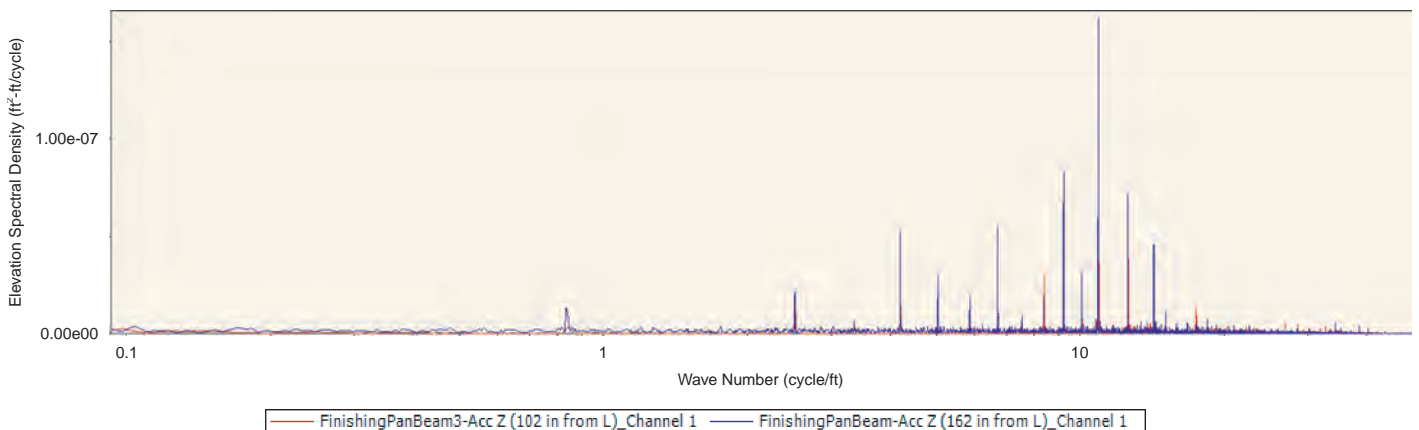
**Figure 2.59. Sample of vertical acceleration data collected on the bridge supporting the profilers (MI-5 and MI-6).**

samples taken at both locations along the beam. These frequencies are likely to be resonant frequencies of the pan and the beam that are being excited by the complex mechanical motion of the paver.

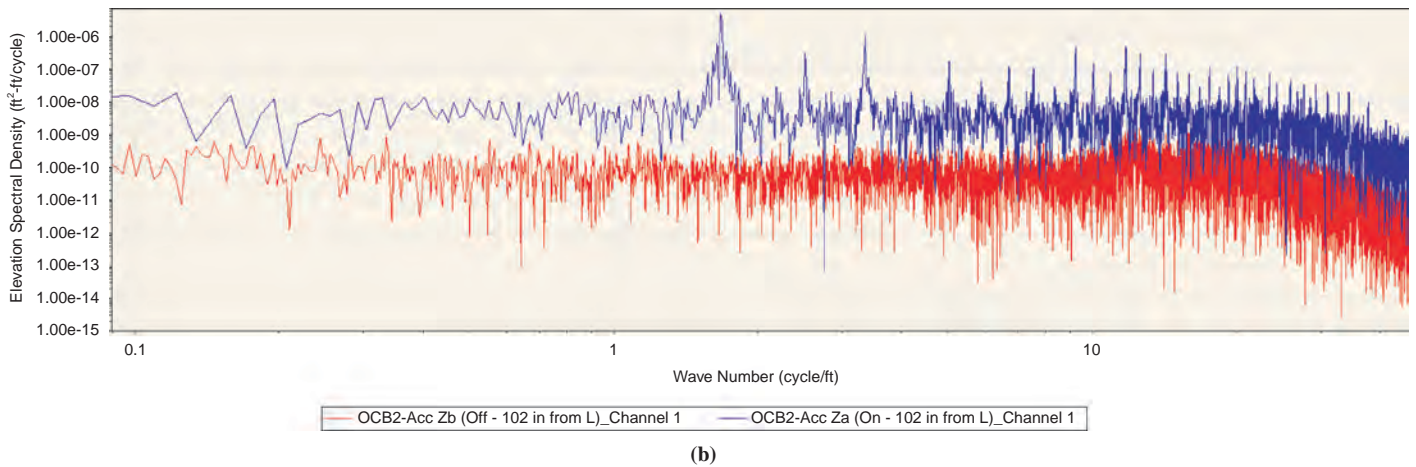
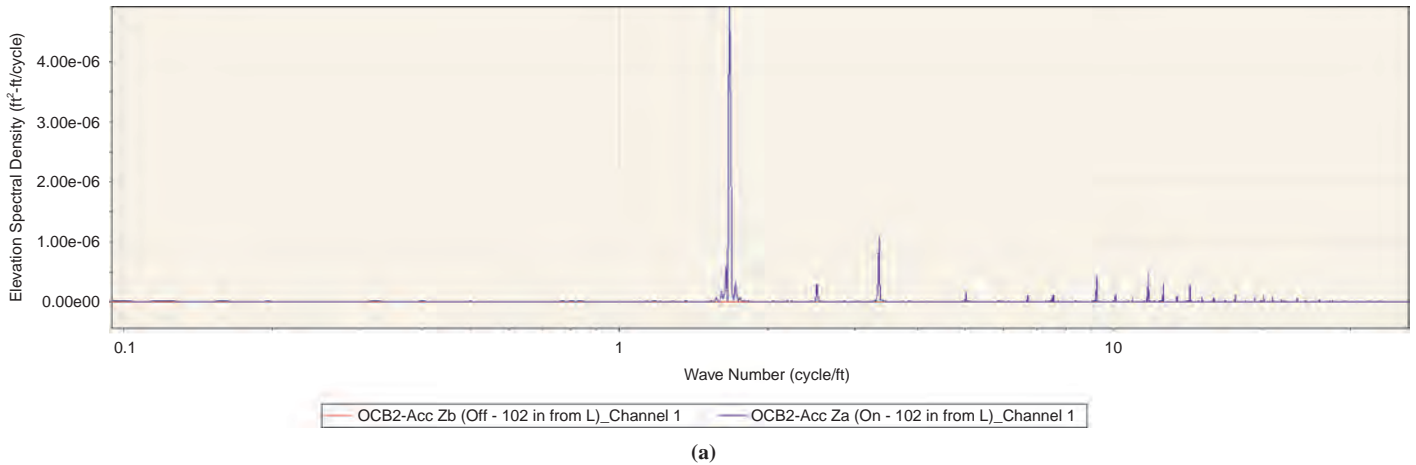
Figure 2.61 shows the PSD analysis of data at the OCB, with the unit both stationary and operating. Figure 2.61a illustrates this with PSD on a linear scale. In this case, the plot of the OCB in the stationary position is a flat line, while the

large peak at 1.66 Hz corresponds to the nominal operating frequency of the OCB (100 rpm). Figure 2.61b shows the same data on a log scale, further confirming the absence of this peak while the unit is stationary.

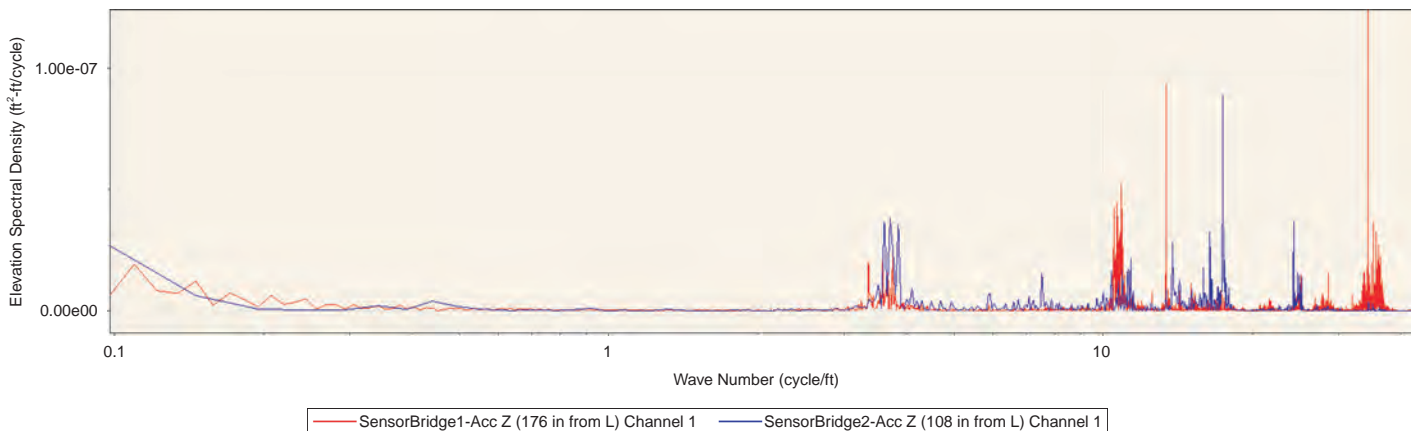
Figure 2.62 illustrates the PSD plots of data collected along the bridge supporting the profilers. From this plot, various frequency peaks can be noted, with many greater than 10 Hz. These peaks are likely caused by the various resonances of the



**Figure 2.60. Spectral analysis of vertical accelerometer data at two different locations along finishing pan beam (MI-1 and MI-2).**

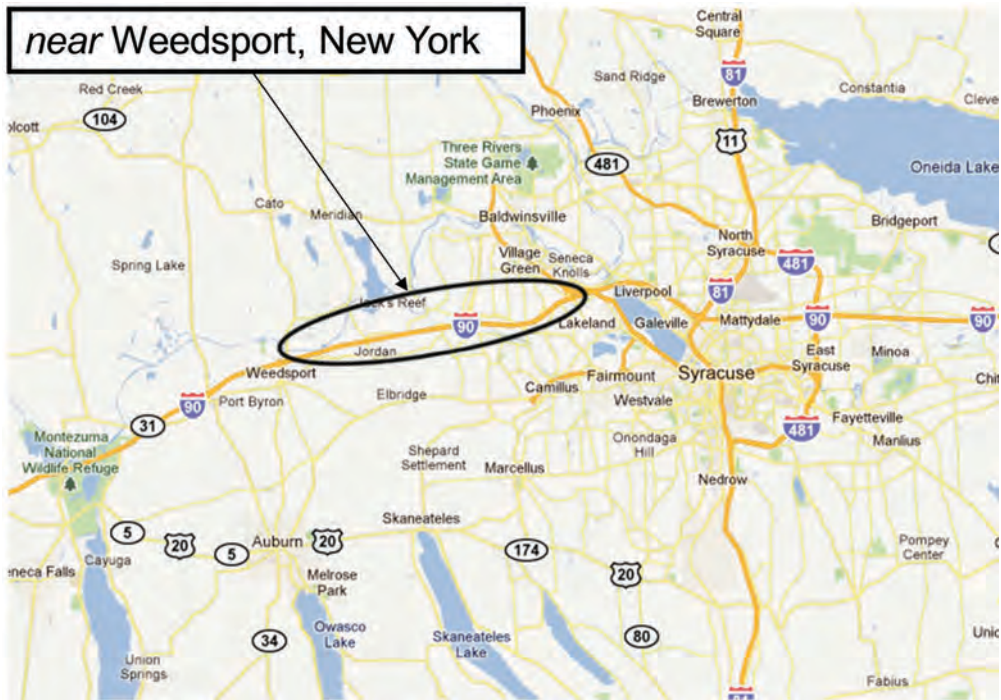


**Figure 2.61. Spectral analysis of vertical accelerometer data at OCB (MI-3 and MI-4) with the PSD on a linear scale (a) and log scale (b).**



**Figure 2.62. Spectral analysis of vertical accelerometer data at two different locations along the bridge supporting the real-time profilers (MI-5 and MI-6).**





© 2011 Google, Map Data.

**Figure 2.63.** Phase 3 technology demonstration project in New York.

whole body motion of the bridge, as well as by the individual segments of the bridge itself.

## New York

The fourth and last technology demonstration was conducted with the Ames Engineering RTP during the week of August 8,

2011, near Weedsport, New York (see Figure 2.63). The contractor, Cold Spring Construction Company, had previously purchased an Ames Engineering RTP unit. The contractor's unit was mounted to the rear of the paver behind the final finishing pan (Figure 2.64). As part of the technology demonstration, Ames Engineering provided a second RTP system that was mounted to a self-powered work bridge (Figure 2.65).



**Figure 2.64.** Contractor-owned RTP equipment mounted to the rear of the paver.



**Figure 2.65.** Additional RTP equipment supplied by Ames Engineering mounted to a work bridge.

Measurements with both units were made along the same path so that comparisons could be more readily made.

In addition to the real-time smoothness measurements, a 1,000-ft section was retested when the JPCP surface was strong enough to support light traffic. Repeat measurements were conducted with the contractor's lightweight profiler and the Ames Engineering RTP. Again, measurements matched the tracks profiled in real time. Surface profiles (real time and hardened concrete) were compared to evaluate accuracy, reproducibility, and repeatability, and the results are summarized in Appendix F.

### **Test Section Description**

The demonstration took place at the Interchange 39-40 reconstruction project by the New York State Thruway Authority in Onondaga and Cayuga Counties, New York. The general contractor for the project was the Cold Spring Construction Company. It was anticipated that the section would experience initial ADT of 43,000 vehicles (26% trucks) based on ADT data for 2009.

The project consisted of the reconstruction of 15.2 mi with JPCP (12.8-in. thick) with transverse joints every 14.8 ft *c/c*. The transverse joints included 1.625-in. dowel bars placed every 12 in. *c/c* for load transfer. Longitudinal joints were held together with No. 6 steel tie bars 15 in. from transverse joints, and then spaced at 40 in. *c/c*. Appendix G provides a typical section for this project and the information provided by the contractor regarding concrete mix design, quality control, and quality assurance testing.

### **Paving Operation**

Ten-cubic-yard batches were produced from a central mix batch plant located near the east end of the project. The concrete mixture was transported in nonagitating dump trucks and deposited on the grade in front of the slipform paver. Typical haul times from the plant site to the paving operation were approximately 10 min.

Consolidation and initial finishing of the pavement were accomplished with a Guntert & Zimmerman 850 slipform paver (Figure 2.66). Internal hydraulic vibrators on the paver were placed at approximately 6 in. from the pavement edge and then subsequently spaced at approximately 14 in. *c/c* across the interior of the pavement. A dowel bar inserter was used to place the load transfer dowels in the transverse joints.

Hand finishing of the pavement behind the paver was performed using 10-ft floats to fill any surface voids and 16-ft straightedges for correcting minor surface deviations. A longitudinal tined texture with 0.75-in. uniform spacing was applied to the pavement surface; this operation typically



**Figure 2.66. Guntert & Zimmerman 850 slipform paver.**

followed approximately 60 min behind the paving operations. Thus curing compound was applied to the pavement surface before any deleterious surface evaporation could occur.

### **Analysis of Events and Observations in Field Data**

Using the cross-correlation analysis feature of ProVAL, each of the profiler runs could be aligned, and the data within the golden section could be parsed for further analysis. The results of the data processing for New York can be found in Appendix F.

In this project, the contractor consistently had higher IRI measurements near the left edge (with respect to the direction of paving) of the pavement; the team tried numerous changes to their operation and equipment adjustments but had been unable to isolate the source of the roughness. They were focused on using the real-time smoothness measuring devices to identify the cause of this roughness and make the appropriate corrections.

Comparing the profile data from the paver-mounted RTP and the work bridge-mounted RTP showed that the paver-mounted unit is still being heavily influenced by the oscillating correcting beam. After the 1-day technology demonstration, the contractor opted to use the work bridge-mounted RTP as the preferred method of using real-time smoothness measurements.

Subsequent to the technology demonstration, the contractor reported that the source of roughness on the left side of the pavement was likely the vibrators nearest that edge of the pavement. Unfortunately this was discovered during the last day of paving on the project and cannot be confirmed until their next paving job with the same equipment.



Again, there was no indication of notable construction artifacts linking to localized roughness. There was one particular feature of interest, however, as described in the following section.

#### *REPETITIVE PROFILE CHARACTERISTIC*

From the PSD analysis on the New York profiles, a repeating feature was evident in the profile at approximately an 18-ft interval. This was noted during the field visit, and various discussions were held between the research team and the contractor to attempt to identify this feature.

One hypothesis for the source of this feature is a manifestation of the length of the paver track, which is approximately 18 ft in length. Figure 2.67 illustrates this for the paver used on the New York project.

A second hypothesis is the possibility of an artifact in the rendering of the model used for continuous adjustments by the stringless guidance system for this paver. The system used is shown in Figure 2.68. It is possible that a subtle but discrete adjustment is being made at a fixed interval because the survey data used to build the model are based on discrete data.

Based on observations of the dump patterns from the concrete trucks, a third hypothesis is that the 18-ft feature corresponds to loads of concrete that would affect the dynamics of the paver as it spreads and extrudes the concrete slab.

#### *Vibration Measurements Analysis*

Acceleration measurements on the New York project were collected at two different locations under a variety of operating conditions. Figures 2.69 through 2.71 show the locations of the mounts. The mount on the paver was located in close



**Figure 2.68.** Stringless guidance system used on New York paving project.

proximity to the Ames Engineering RTP. The mount on the bridge was located at a hard point on the bridge itself, in line with the RTP mount along a vertical axis. Because vertical accelerations were of most interest, this was believed to be a representative location.

The various locations and operating conditions evaluated in New York are summarized in Table 2.3.

Figure 2.72 illustrates approximately 15 s of vertical acceleration data at the paver-mounted device. The configuration in this instance is nominally the same as that during data collection for the golden section at this site. The angle iron was clamped to the profiler mount, and the three dowels that were clamped to the RTP remained.



**Figure 2.67.** Length of paver track is a possible explanation of a repeating feature in New York profiles.



**Figure 2.69.** Location of Inertia-Link sensor with respect to the paver-mounted Ames Engineering RTP, with dowels used for mass dampening.



**Figure 2.70. Location of Inertia-Link sensor on paver-mounted Ames Engineering RTP without dowels.**

Figure 2.73 includes data from the same nominal sensor position, but with the clamp to the angle iron removed. Through a casual observation of the waveform, the dominant frequency is noted to change (decrease) with the clamp removed. This behavior is expected given the additional degree of freedom resulting from removal of the clamped support.

Figure 2.74 includes a sample of data with the dowel bars affixed to the RTP removed. The dominant frequency is noted to increase as a result, which is to be expected given the lower mass.

Figures 2.75 through 2.78 illustrate data collected to represent the vertical accelerations of the bridge-mounted RTP. Three different forward speeds of the bridge were evaluated



**Figure 2.71. Location of Inertia-Link sensor on bridge-mounted Ames Engineering RTP.**

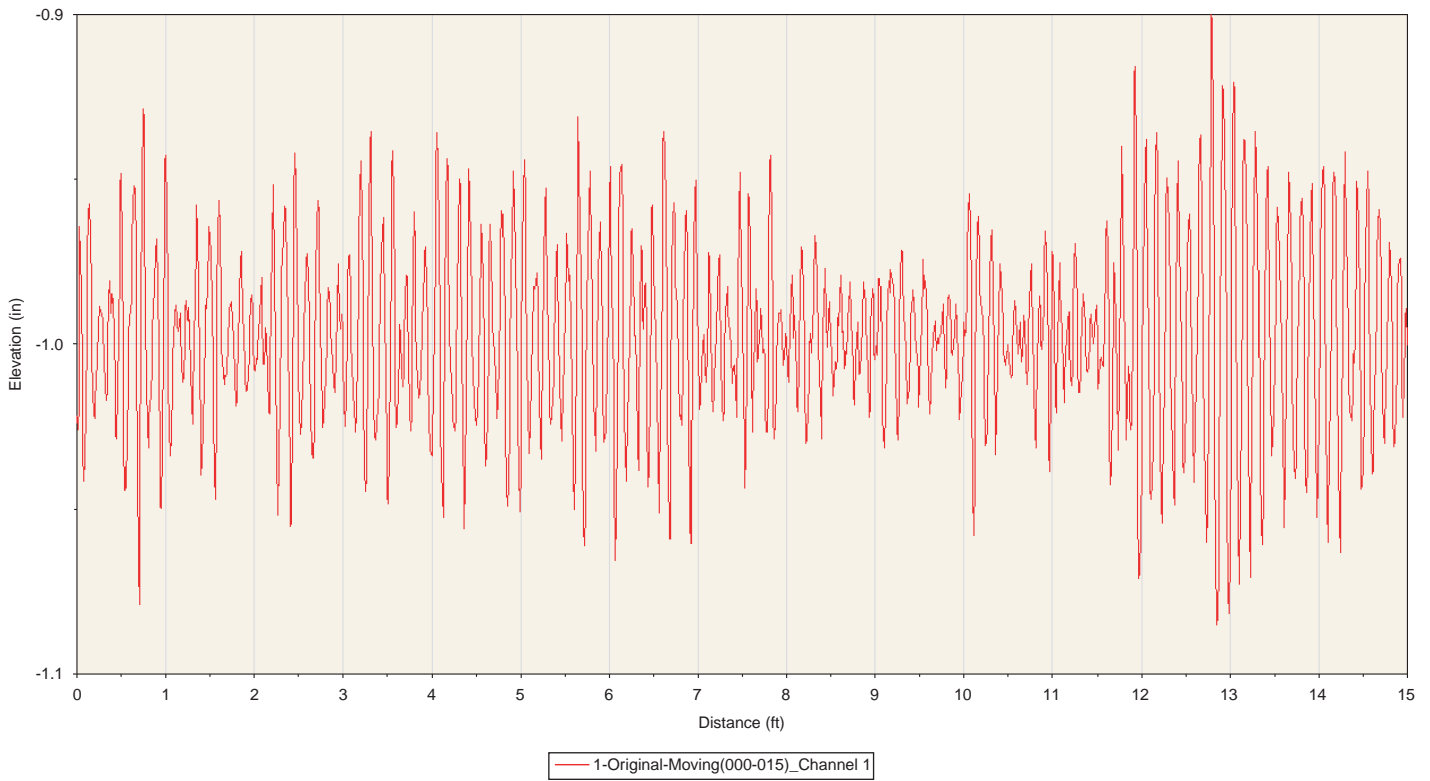
(9, 16, and 24 fpm), along with a measurement where the bridge was not moving. From these figures, it appears that the waveforms (including frequency and amplitude) are very similar among all of these operating conditions.

Figure 2.79 further illustrates the observations about the frequencies previously stated for the paver-mounted device. Figure 2.80 further demonstrates the coincidence of the frequencies for the bridge-mounted device.

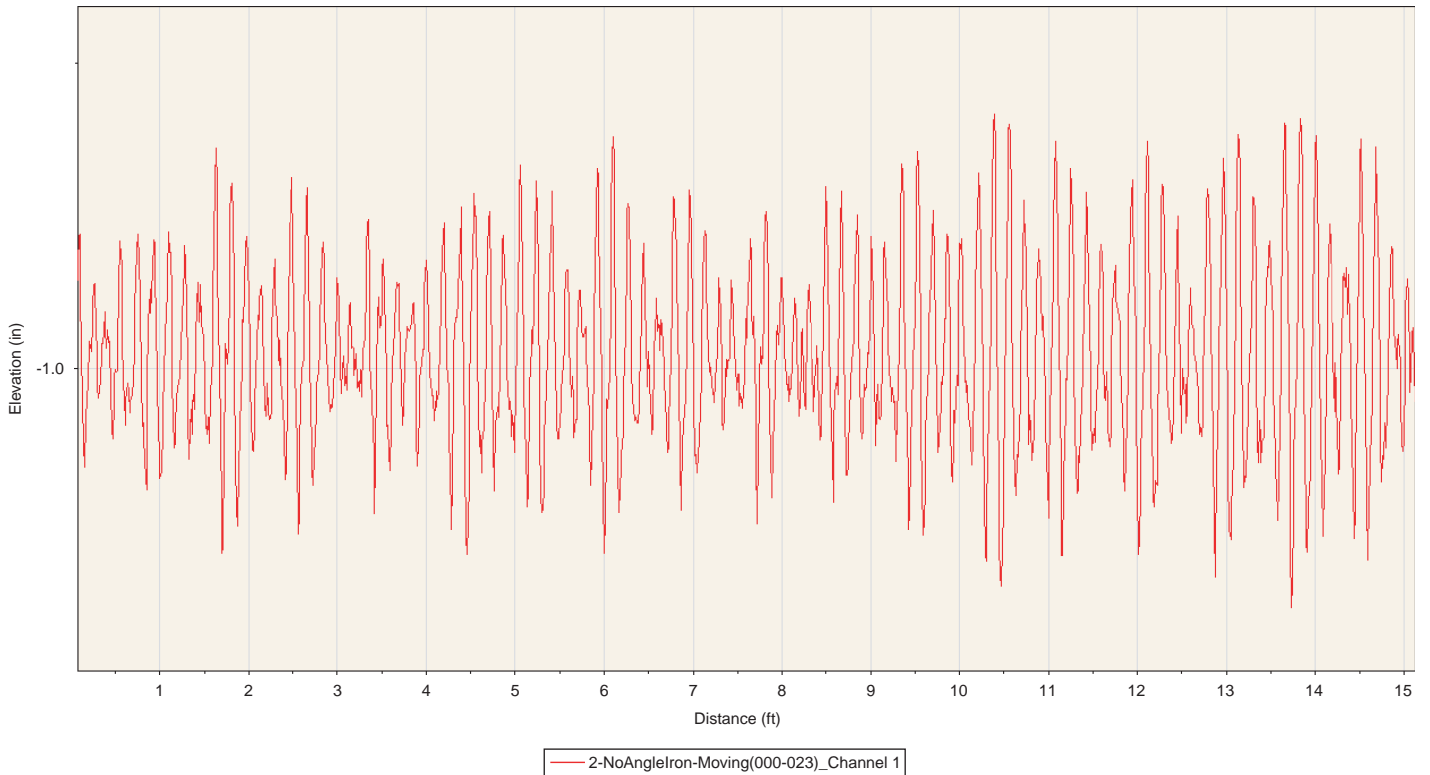
**Table 2.3. Summary of Inertia-Link Sensor Locations and Operating Conditions for New York**

| Measurement Sequence | Mount  | Operating Configuration/Condition  |
|----------------------|--------|--|
| NY-1                 | Paver  | Paver in motion—RTP in same nominal configuration used for golden section testing (with dowels and clamped angle iron support) |
| NY-2                 | Paver  | Paver in motion—clamped angle iron support removed   |
| NY-3                 | Paver  | Paver in motion—clamped angle iron support and dowels removed  |
| NY-4                 | Paver  | Paver stopped—clamped angle iron support and dowels removed  |
| NY-5                 | Bridge | Bridge advancing at 9 fpm  |
| NY-6                 | Bridge | Bridge advancing at 16 fpm   |
| NY-7                 | Bridge | Bridge advancing at 24 fpm   |
| NY-8                 | Bridge | Bridge stopped   |

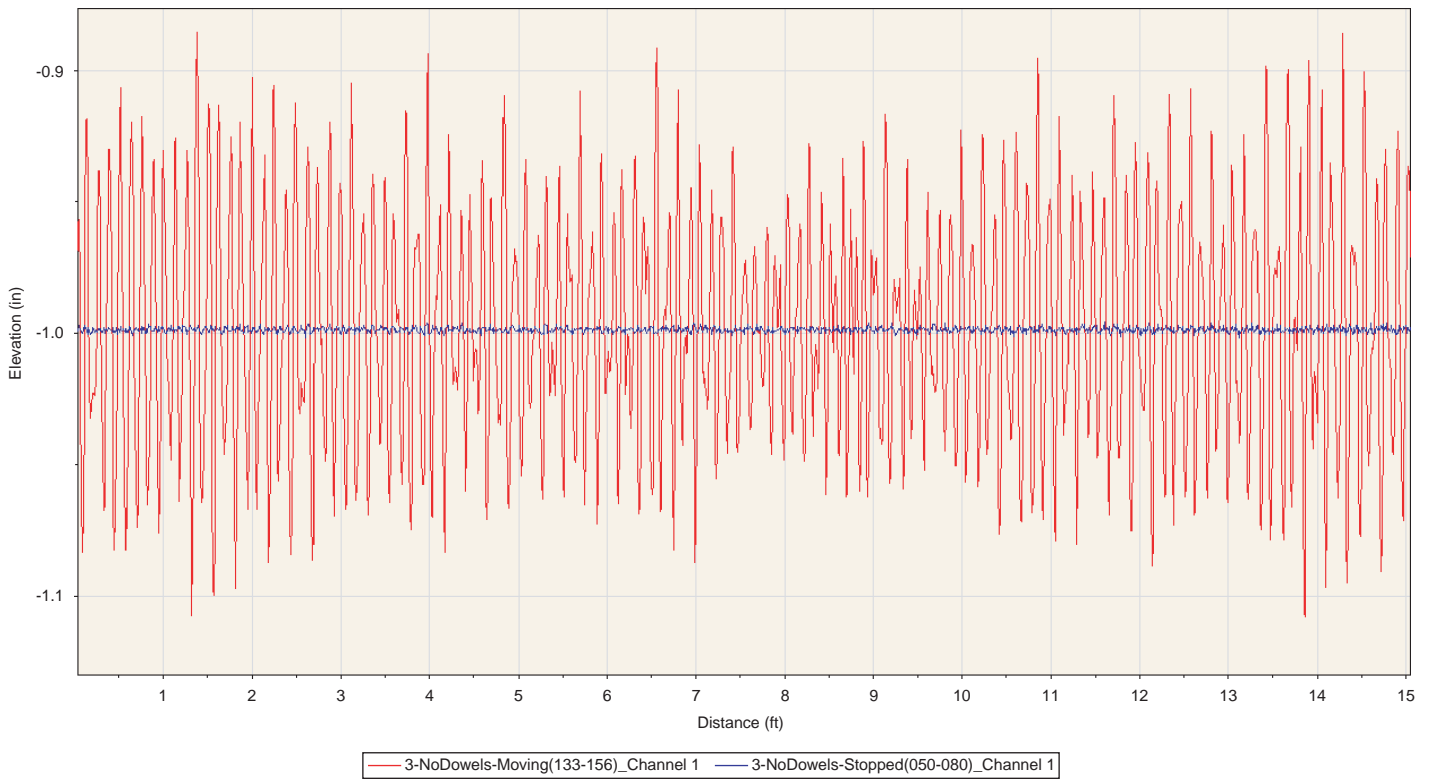
Note: fpm = feet per minute.



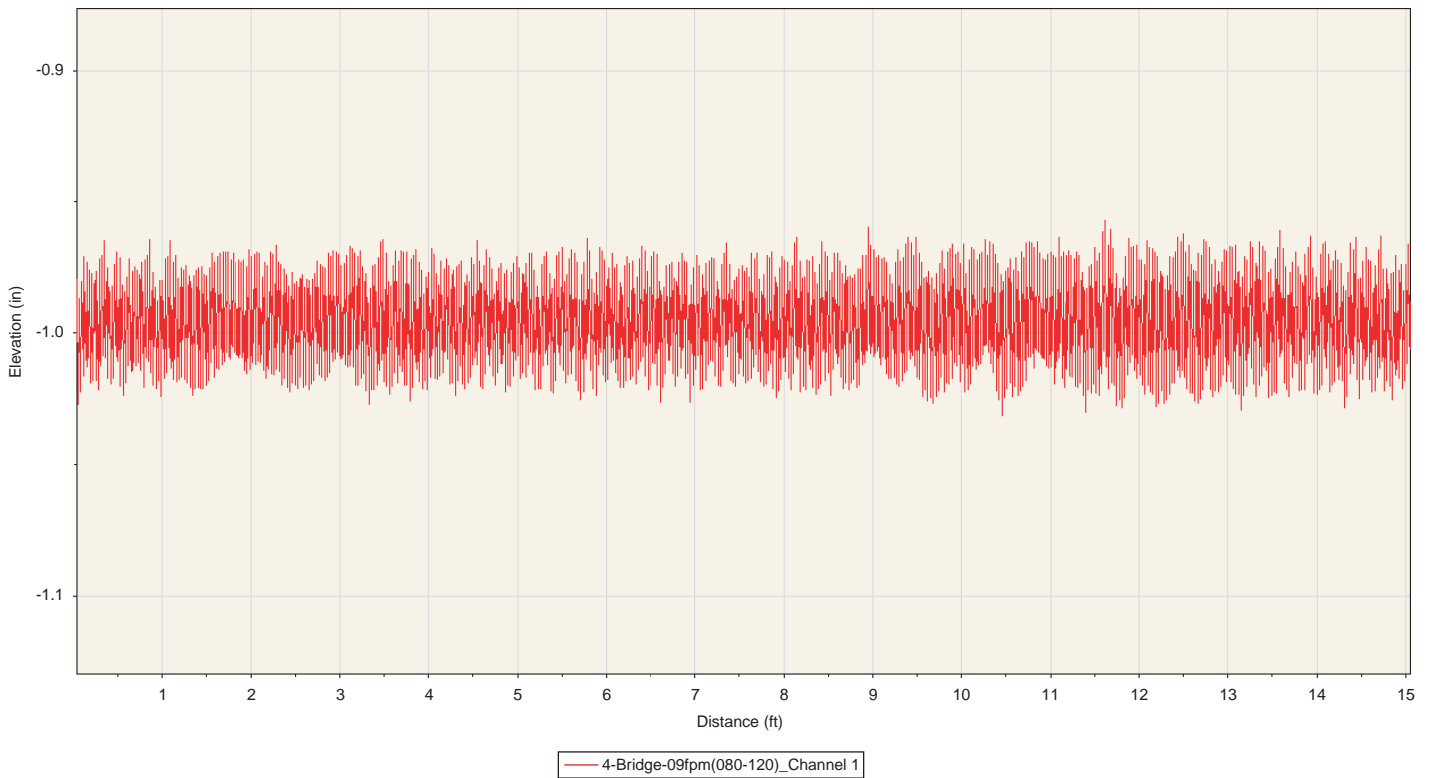
**Figure 2.72. Sample of vertical acceleration data collected on the paver with the clamped angle iron and dowels affixed (NY-1).**



**Figure 2.73. Sample of vertical acceleration data from the paver with angle iron unclamped, but dowels remain affixed (NY-2).**

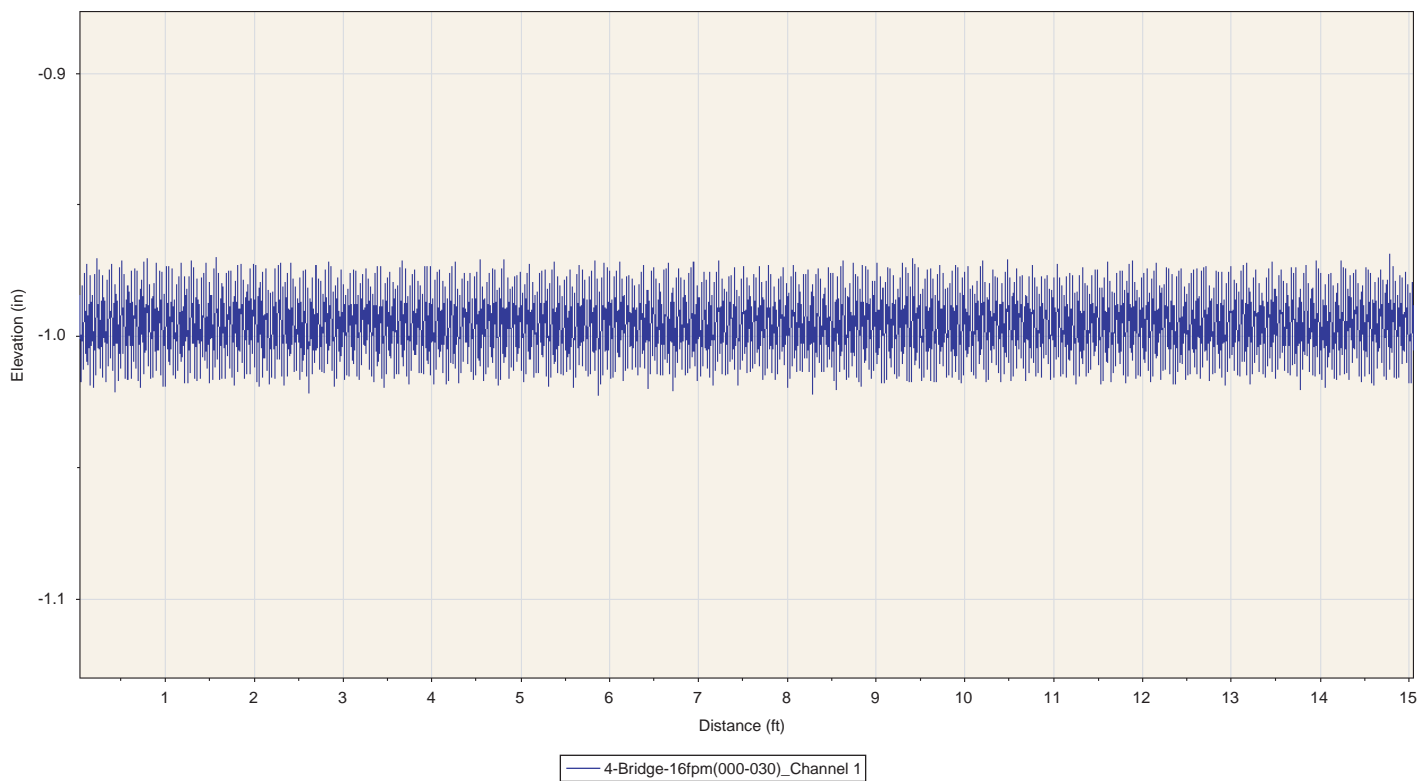


**Figure 2.74.** Sample of vertical acceleration data from the paver with the angle iron unclamped and dowels removed, both with the paver moving (NY-3) and stationary (NY-4).

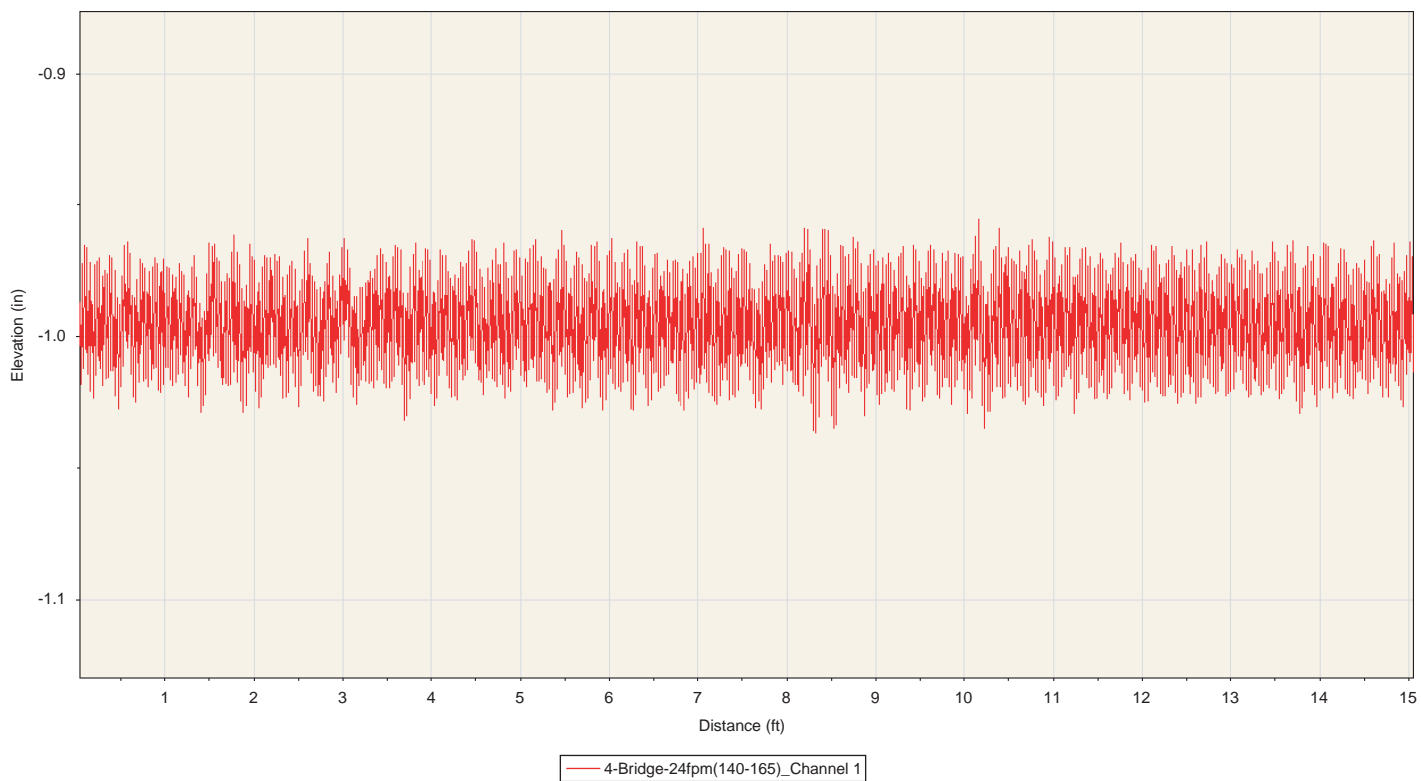


**Figure 2.75.** Sample of vertical acceleration data from the bridge moving at 9 fpm (NY-5).

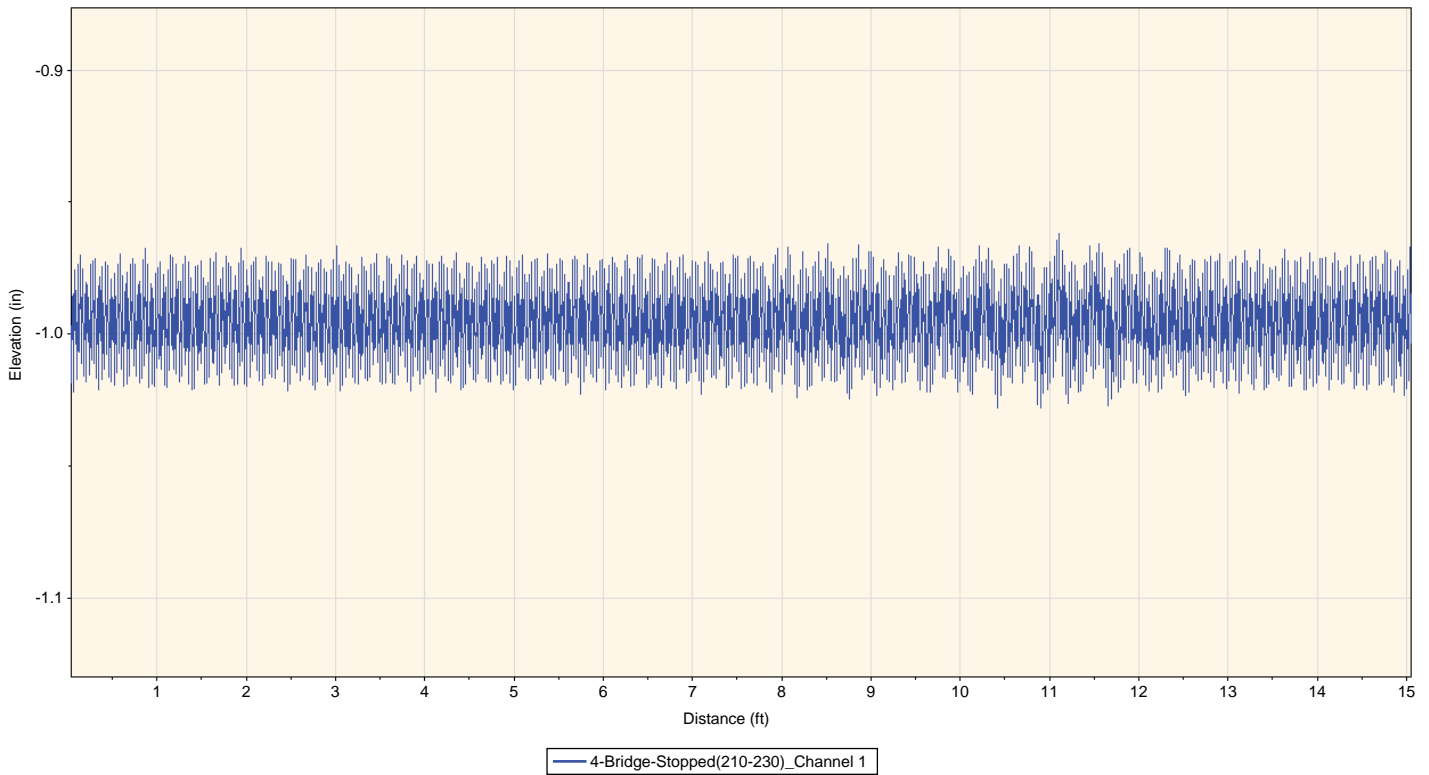




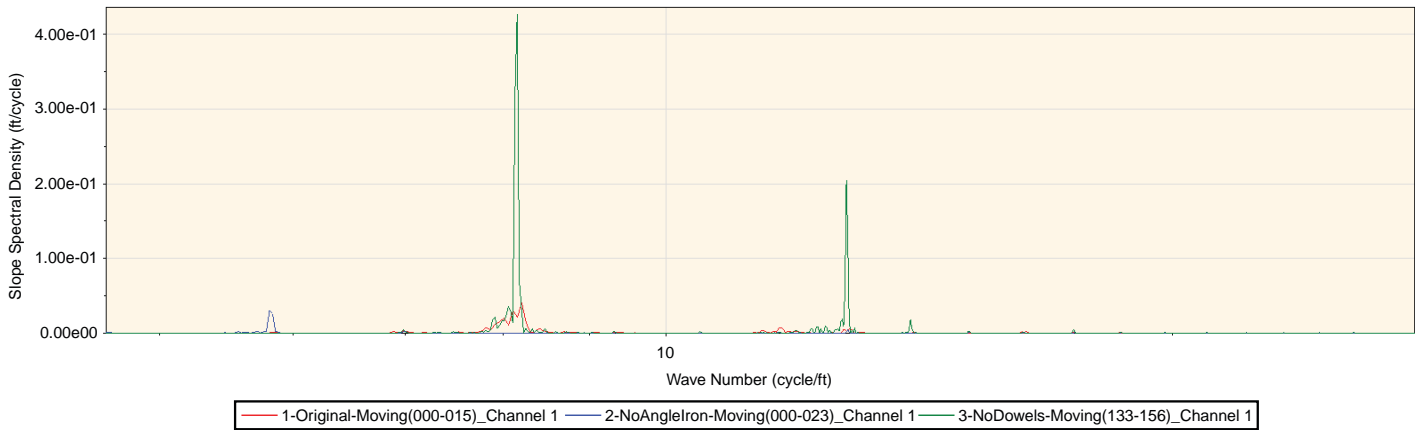
**Figure 2.76. Sample of vertical acceleration data from the bridge moving at 16 fpm (NY-6).**



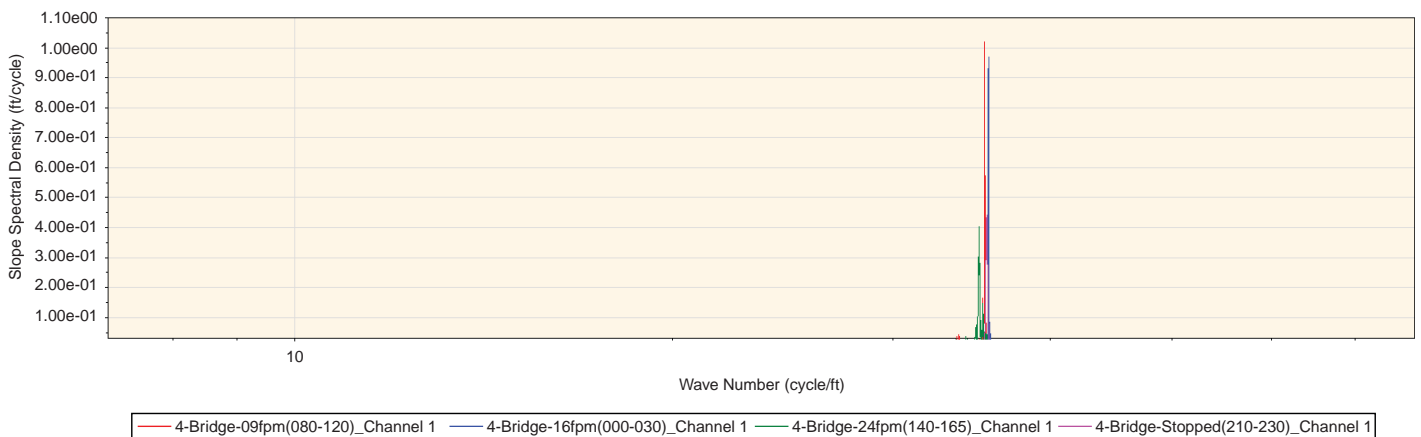
**Figure 2.77. Sample of vertical acceleration data from the bridge moving at 24 fpm (NY-7).**



**Figure 2.78. Sample of vertical acceleration data from the stationary bridge (no forward motion) (NY-8).**



**Figure 2.79. Power spectral density plot of samples collected on the paver.**



**Figure 2.80. Power spectral density plot of samples collected on the bridge.**

## CHAPTER 3

# Findings and Applications

### Summary of Technology Performance

Demonstrating the real-time profilers on projects with such varied conditions allowed the research team to evaluate the viability of this technology. On each project, there appeared to be one or more challenges to the technology, with the most notable being sources of excess vibration. On the basis of the cross-correlation results, it appears that the paver-mounted units are the most susceptible to this type of potential contamination. On all but one of the projects demonstrated, the principal source of vibration was the OCB.

From the cross-correlation numbers, it can be concluded that neither technology is capable of measurements suitable for quality assurance (QA). This was to be expected, however. It also appears from a review of the data collected that the real-time profiler should not be used for quality control (QC) but should be used instead for process monitoring and improvement. Because these profilers provide real-time feedback of process modifications, overall paving quality can be improved in short order. As such, it can be of significant value to both the contractor and the owner-agency, particularly when they are working under a stringent ride quality specification.

### Summary of Technology Refinements

Chapter 2 outlined recommendations for technology refinement that the team made to both vendors at the end of Phase 2. The first task in Phase 3 consisted of conference calls with both vendors to discuss these recommendations.

During Phase 2 it was demonstrated that the GOMACO GSI possesses a simple, intuitive, and powerful real-time display. However, a similar feature was not demonstrated live for the

Ames Engineering RTP and, consequently, the vendor accomplished significant improvements during Phase 3, as described in the following section. A recommendation that is still valid for both technologies consists of developing a robust system of error checking and shake-down procedures to alert the real-time profiler operators of problems with the system.

### Ames Engineering RTP

Ames Engineering changed the encoder wheel assembly from a 27-in. bicycle wheel to a 20-in. wheel. This helped make the system more portable, in that it is easier to move, mount, and store. The hardware change prompted a recalibration of the distance measurement system, but the profiler still provides output at the same distance interval. This change was made before the New York demonstration. Ames Engineering also adapted the mounting hardware during this study in response to the unique challenge posed as new paving equipment was encountered at each demonstration.

The device was upgraded to include a Toughbook CF-19 to improve visibility of the display in the field, with the option to use a CF-31. Ames Engineering also upgraded the device software throughout this research. The upgraded software includes higher contrast colors to improve visibility of the display in field conditions. Figure 3.1 and Figure 3.2 show a display of two elevation traces and paver speed versus distance and a listing of defective segments based on a short-interval continuous report of IRI.

### Development of Specifications and Guidelines

A complementary objective of this research was to draft model specifications and construction guidelines to facilitate evaluation and implementation of real-time smoothness measuring

technologies by state highway agencies and concrete paving contractors. During Phase 1 of this study, a review of smoothness specifications and better practice guidelines was con-

ducted to begin development of a draft model specification for real-time smoothness measurements and a generic set of better practices to improve smoothness.

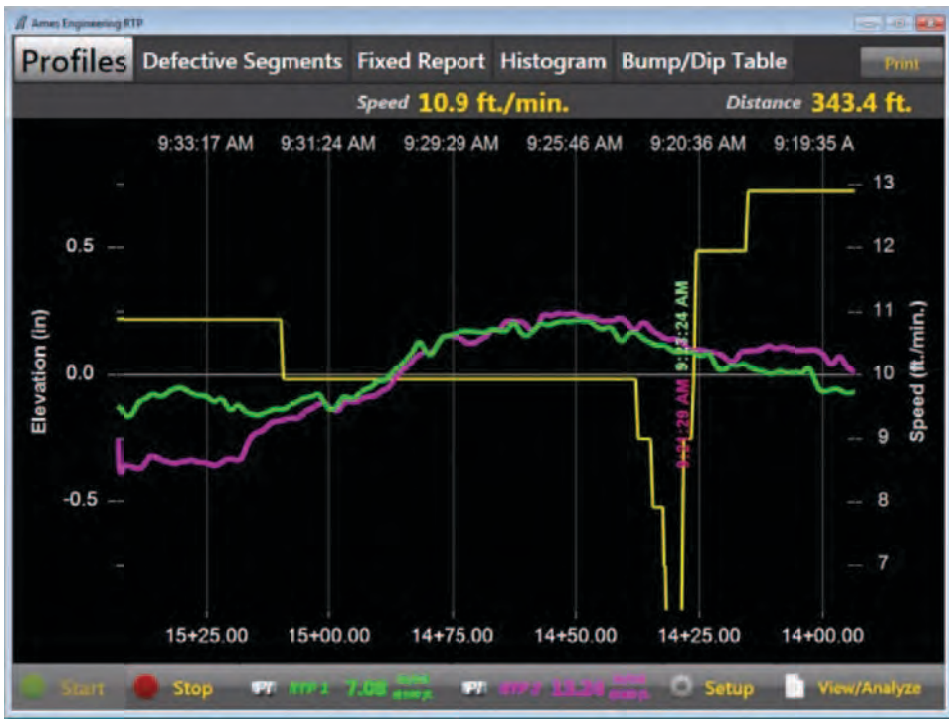


Figure 3.1. Ames Engineering RTP elevation display.

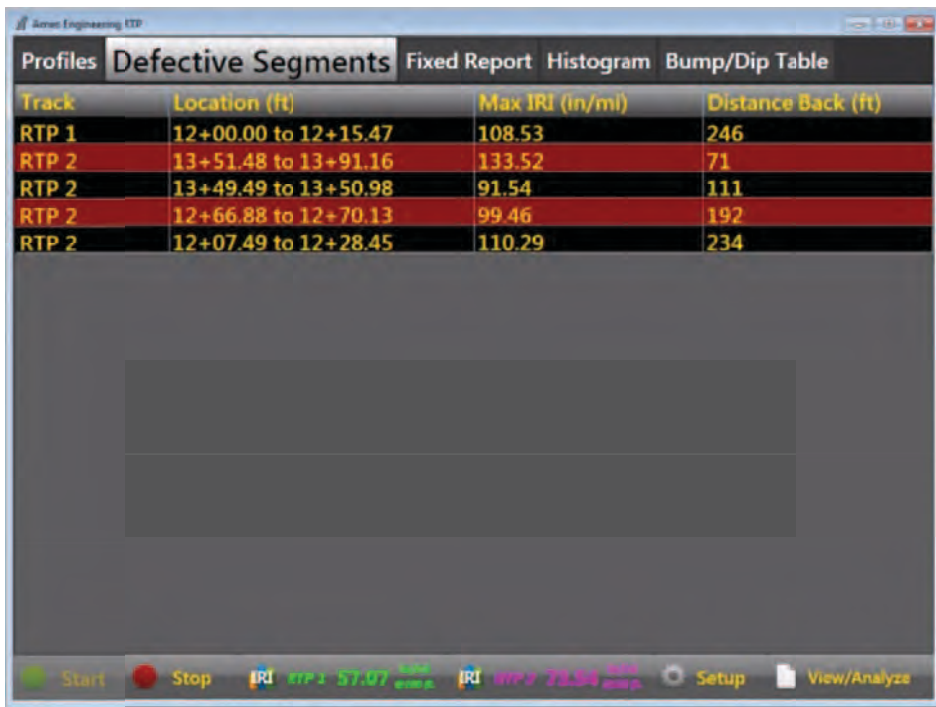


Figure 3.2. Ames Engineering RTP defective segments display.



These documents were refined based on the results from the Phase 2 field evaluation and Phase 3 field demonstrations. Appendix H presents a draft model specification with the recommended practice for conducting real-time smoothness measurements. This chapter presents construction guidelines to recognize and address objectionable profile characteristics in real time.

## Model Specification

During the Phase 1 review of smoothness specifications, four different AASHTO standards were identified (M328-10, R54-10, R56-10, and R57-10), which address lightweight and high-speed inertial profiler equipment requirements, operational procedures, and protocols for construction acceptance testing. These documents were referenced to develop complementary guidance and specifications for smoothness measurements in real time.

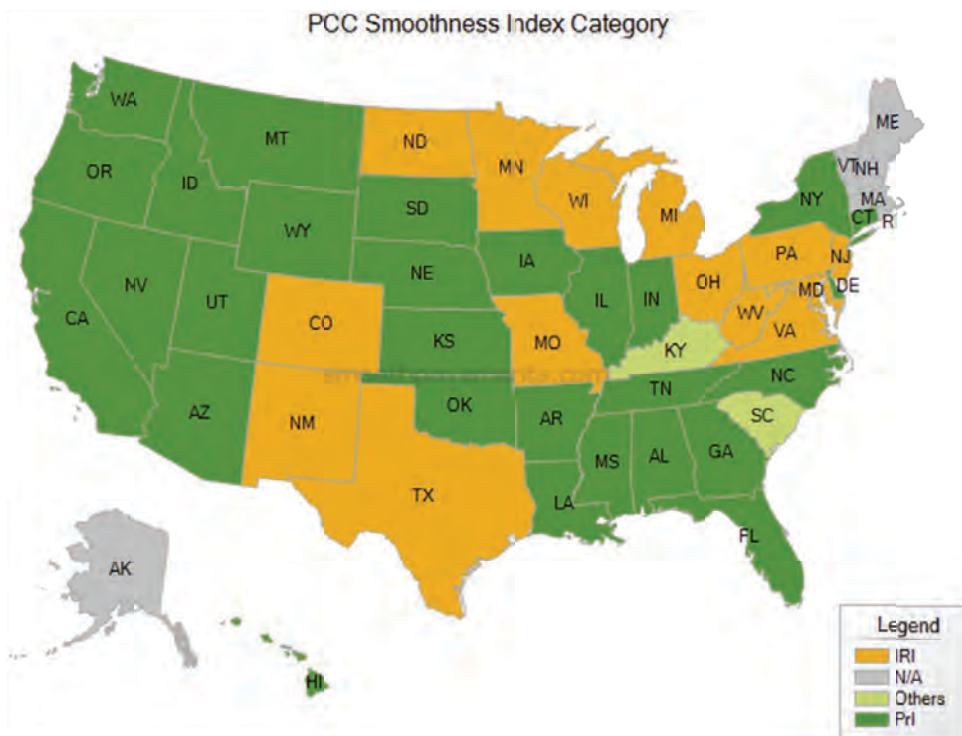
In addition to AASHTO standards, state highway agency smoothness specifications were also reviewed, including those used by the Kansas DOT and the Texas DOT for concrete pavements. The Kansas DOT specification is based on PI mea-

surements, and the Texas DOT ride quality specification is based on IRI. The model specification developed under this effort covers similar aspects for smoothness measurements in real time, including equipment requirements, operational procedures, and data evaluation.

Language and concepts from the current AASHTO standards were used as the basis for the model specification, but recognizing the key differences that define real-time measurements. Among their differences is using real-time smoothness measurements as a quality control tool and not as a replacement for quality acceptance testing. Note that the most logical place to use the model specification developed under this effort is as part of a Quality Management Plan (QMP) and not directly in the project specifications.

## Smoothness Statistics

Figure 3.3 shows the smoothness indices used by state highway agencies in their specifications for construction of new concrete pavements. Note that a large number of states are still using profilograph measurements and the corresponding



Source: SmoothPavements.com.

**Figure 3.3. Summary of smoothness indices specified for construction of new concrete pavements by state highway agencies. PCC = portland cement concrete; IRI = international roughness index; N/A = not available; PrI = profilograph index.**

PI. However, there are numerous states already using or transitioning to IRI-based specifications. The main reason for this change is the availability of lightweight profilers that provide IRI measurements of newly constructed concrete pavements that are consistent with high-speed profiler measurements conducted later in the life of concrete pavements for inventory and resurfacing purposes. This effort focused on using the IRI index for consistency purposes as well.

Note that the smoothness statistics for profiles measured in real time differ from the smoothness statistics for profiles measured on the final surface. Measurements with real-time systems do not reflect roughness artifacts introduced later during the paving operation, such as texturing and joint sawing, or subsequent effects, such as those caused by curling and warping. Furthermore, as described in Chapter 2 (laser gun swap event section) and revealed by Figure 2.30, smoothness measurements also depend on the location of the real-time system along the paving train (i.e., attached to the back of the paver versus a work bridge before or after the hand finishers).

The data from the Phase 3 field demonstrations were examined in an effort to compare the profiles and corresponding IRI values measured in real time and the final measurements during the hardened concrete testing (QC/QA). No meaningful trends were observed so far, in order to develop rational limits for “real-time” smoothness statistics (IRI) or a reliable relationship to the final IRI. Note that collected data are limited to four sites.

This difficulty has been previously documented by Cable et al. (2005), in a study in which the GSI and RTP devices were initially evaluated. Real-time measurements were taken at different stages of the paving operation, including measurements behind the paver (profile pan), after finishing operation, after the texturing and curing machine, and on the final hardened surface. On the one hand, for the GSI device, the final profiles measured on the hardened surface did not have a strong correlation to the profiles measured in real time. Two possible contributing factors were identified: the first factor being genuine profile changes as paving progresses, and the second factor being differences between the GSI and the lightweight profiler that was used. On the other hand, a clear relationship was found between the RTP and the inertial profiler measurements, but it was further noted that both devices were built by the same manufacturer and, more importantly, were based on similar measurement technologies.

Chapter 2 described how one of the technologies (GOMACO GSI) uses the GSI number in its live display, which represents the IRI value averaged over a short segment of road terminating the position of the profiler. Although the GSI number is conceptually the same as a short interval report of the IRI, the unique name helps avoid confusion during wet pavement

operation because the user should not expect the roughness of the surface to remain the same through other stages of the paving process. A similar approach is recommended when using other technologies. In addition, it has to be emphasized that the real-time smoothness values will vary significantly from project to project based on the real-time system setup, project features, and so forth.

An item generally covered in state highway agency smoothness specifications is a pay schedule with incentives and disincentives. This aspect is not included in the model specification presented herein, however, because of the inability to develop rational limits for “real-time” smoothness statistics (IRI) or a direct relationship to the hardened concrete IRI at this point in time.

### ***Additional Detailed Analysis***

In addition to monitoring the smoothness statistic behind the paver, the model specification (Appendix H) recommends employing additional analysis techniques to take full advantage of the quality control applications of this technology. Chapter 2 documented how, during Phase 2 field evaluations and Phase 3 field demonstrations, it was demonstrated that these technologies are capable of identifying objectionable profile characteristics in real time (or nearly real time). This capability allows the paving contractor to make adjustments and achieve a smoother surface.

### ***Equipment Requirements***

As described in Chapter 2, existing and potential technologies to measure smoothness in real time are very diverse in terms of overall measurement principle, physical layout, sensor specifications, and so forth. Therefore, instead of outlining a strict list of technical requirements, the model specification aims to define requirements to provide valid and meaningful real-time smoothness feedback to the paving crew. These requirements include a system capable of measuring and storing profile data, with real-time viewing and analysis capabilities. A key item is the IRI calculation and display in real time. It is important that the real-time display is easily accessible to key members of the paving crew, such as the paving superintendent, project engineer, paver operator, and hand finishers.

### ***Equipment Setup and Mounting***

There are numerous possible sensor configurations for the real-time devices, including attaching the system to the back of the paver or using a stand-alone work bridge or dedicated machine (GOMACO GSI) located behind the hand finishers or texture/cure cart. A combination of sensors may be used as well, such as

having a sensor attached to the paver, followed by sensors on a work bridge behind the hand-finishing operation.

Different considerations apply to each configuration. For example, measurements with a system mounted to the back of the paver may be subject to contamination from paver-related vibrations as was documented during the Phase 3 field demonstrations in which oscillating correcting beams were used (see Chapter 2). The model specification recommends that the paving contractor works closely with the technology manufacturer to determine and accomplish the appropriate mounting configurations required for the different scenarios and applications.

### **Equipment Verification**

Accuracy and repeatability testing of the real-time smoothness measuring technologies represents a complex task because the concrete pavement profile changes as the paving operation progresses from the placement of the concrete, to finishing, texturing, application of curing, and the saw cutting of joints. Additional changes caused by shrinkage and diurnal effects further complicate the evaluation of the section, particularly if measurements on the hardened concrete surface are compared with those measured in real time.

A procedure based on the Phase 2 field evaluation and the hardened pavement profile measurement experiment presented in Appendix B is recommended for verification of the real-time system. A key recommendation in the model specification is the cross-correlation analysis for profile comparison.

### **Operational Procedures**

The work methods section in the model specification stresses the importance of documenting the relevant events during the paving operation that are expected to have an impact on smoothness, such as track line roughness, leave-outs, and so forth. Furthermore, it is important to supplement this information with field notes describing frequent paver stops, sudden changes in paver speed, paver adjustments, material placement ahead of the spreader, concrete head in front of the paver, auger usage, and hand-finishing activity. If the time and location of these events are documented, different profile analysis techniques may be employed in real time (or nearly real time) to assess their impact and make any necessary adjustments. The event marker feature in real-time systems is likely to assist in this task.

It is also recommended to inspect for track line roughness before beginning the real-time measurements, as was presented throughout Chapter 2. Similarly, it is recommended to mark “leave-out” sections such as turning lanes, horizontal

curves with radius of curvature less than 1,000 ft, and super-elevation transitions that are exempt from smoothness specifications requirements. Real-time feedback is still valuable along these sections, but marking these sections will help to explain abrupt changes in real-time smoothness.

### **Software and Data Evaluation**

The data evaluation in real time is to be conducted with the specific technology computer display and accompanying software, which at a minimum should include a display with profile elevations and IRI data, and feature tools to identify localized roughness. Data are to be reported in a format readable by ProVAL (e.g., ERD files) and submitted to the project engineer throughout the day to conduct more detailed analysis as required.

### **Generic Set of Better Practices to Improve Smoothness**

A literature review was conducted to identify better practice guidelines that can be used to recognize and address objectionable profile characteristics, identify their causes, and learn how to prevent or correct them. Three primary publications were considered for this review. The first reference was *Integrated Materials and Construction Practices for Concrete Pavement: A State-of-the-Practice Manual* (Taylor et al. 2007). This manual is a comprehensive document that addresses all aspects of concrete pavement construction, from design and material requirements to construction and evaluation. A second key reference reviewed was the FHWA report, *Smoothness Criteria for Concrete Pavements* (Perera et al. 2009). This report presents the results of an extensive 5-year research project that addressed ride quality and pavement performance, covering items such as construction, smoothness testing, and profile data evaluation. Finally, the FHWA report, *PCC Pavement Smoothness: Characteristics and Best Practices for Construction* (Grogg and Smith 2001), was reviewed. This report addressed construction activities and their impact on smoothness.

Table 3.1 summarizes the results of the information collected from these three primary references, supplemented by the observations and information gathered during the field evaluation and field demonstrations conducted under this study. The table is organized by objectionable profile characteristics that are likely to be identified and possibly corrected in real time.

Chapter 2 and the model specification in Appendix H describe methods to interpret real-time smoothness measurements for construction quality control using filtering techniques, PSD plots, and continuous IRI and PI reports.

**Table 3.1. Summary of Objectionable Profile Characteristics and Better Practice Guidelines to Prevent Them**

| Profile Characteristic  | Description  | Methods to Identify Profile Characteristics in Real Time   | Better Practice Guidelines  |
|---|--|--|---|
| String line effects   | The state of the practice is to construct concrete pavements with string line grade control. A sagging or a disturbed/broken string line will reflect on the pavement profile.   | String line sags will likely appear as repetitive features in the filtered profile. PSD plots will allow confirmation of this feature.<br>It can be checked if a string line disturbance/break had a significant impact on the final surface by checking the continuous IRI report at that location.   | Use two string lines, one on each side of the paver.<br>Use aircraft cable to increase the applied tension and minimize sags. Do not use nylon strings.<br>Place string line outside the paving limits to minimize disturbances by paving equipment, construction traffic, and workers. Extension arms and trusses are available to move paver sensors to the offset string line.<br>Use a maximum stake spacing of 25 ft, and closer spacing for curves and superelevation transitions.<br>Continuously monitor and maintain string lines. |
| Stringless guidance system operation effects  | Phase 2 involved a slipform paver with a stringless guidance system, which eliminates issues with sagging or broken string lines. However, the research team documented frequent and periodic paver stops to relocate the total stations for the system as the paving operation progresses, which may have an impact on smoothness. This issue was documented in Chapter 2.  | This profile characteristic may appear as a repetitive feature or as a one-time occurrence.<br>Inspecting filtered profiles, PSD plots, and checking the profile against field inspector notes will help identify this feature in the profile.<br>Also, a continuous IRI report can be used to alert staff about demonstrations of localized roughness events.   | At this point, a recommendation is to work closely with the stringless system manufacturer to optimize its operation and minimize the number and impact of paver stops to relocate total stations.  |
| Concrete loading/delivery effects   | Delivery of an inconsistent mix or delivery at inconsistent rates to the paver can result in significant changes in the concrete head in front of the paver. The paver will have to adjust to these changes, affecting the final profile surface.  | This profile characteristic may appear as a repetitive feature or a one-time occurrence.<br>Inspecting filtered profiles, PSD plots, and checking the profile against field inspector notes will help identify this feature in the profile.<br>Based on observations during the Phase 2 field evaluation, smoothness variations can be easily monitored by the paving operator using the real-time smoothness statistic displayed by one of the real-time profilers. | Address segregation and workability in design to ensure a consistent mix.<br>Perform continuous and rigorous quality control.<br>Ensure constant speed of paving and constant rates of delivery. Plan truck routes to prevent inconsistent delivery and frequent paver stops.<br>Use a spreader to promote a consistent head of concrete ahead of the paver.  |
| Dowel basket in JPCP and transverse reinforcement steel in CRCP/JRCP effects <sup>a</sup> | Dowel baskets or transverse reinforcement and chairs make proper consolidation difficult to achieve. Voids are created that lead to inconsistencies in the mix, which can affect strength and durability. In addition, at these locations the concrete may settle and create dips in the profile.<br>As the paver approaches, dowel baskets may dam up fresh concrete, increasing concrete head at the front of the paver. This can affect the profile.<br>Pressure exerted onto the baskets as the paver passes over them may cause the baskets to lean forward. Once the paver has passed, the baskets may bounce back into place (rebound). This movement can affect the profile. | Dowel baskets/transverse steel will likely appear as repetitive features in the filtered profiles and PSD plots can help confirm this feature.<br>Chapter 2 presented an example of how filtered profiles and PSD plots can be used to identify transverse steel reinforcement effects.  | Fasten dowel baskets to base course.<br>Place concrete over dowel baskets before paving.<br>Do not cut spacer wires.<br>Use dowel bar inserting equipment.<br>Use v-floats or oscillating beam floats to remove dowel basket rebound and rippling effects.  |

(continued on next page)



**Table 3.1. Summary of Objectionable Profile Characteristics and Better Practice Guidelines to Prevent Them (continued)**

| Profile Characteristic       | Description  | Methods to Identify Profile Characteristics in Real Time  | Better Practice Guidelines   |
|------------------------------|--|---|--|
| Localized roughness/ "bumps" | <p>Any change in the forward motion (velocity) of the concrete paver may result in an event of localized roughness.</p> <p>Headers (transverse construction joints) are another common cause of localized roughness.</p> <p>Another source of localized roughness documented throughout Phase 2 and Phase 3 of this study is track line roughness.</p> | <p>Monitoring the continuous IRI report can be used to alert staff about demonstrations of localized roughness events.</p> <p>Chapter 2 presented examples of how a continuous IRI report can be used to flag localized roughness events.</p>   | <p>Maintain constant speed of paving and, when a change in speed is required, it is preferred to slow down the operation rather than stopping.</p> <p>Coordinate production rates and delivery vehicles, to avoid changes in paving speed.</p> <p>Avoid headers by using a cutback method to create a clean and smooth joint.</p> <p>Extend the base 3 ft beyond the edge of the concrete pavement to give a stable track line for the slipform paver to follow.</p> |
| Finishing effects            | <p>Improper use of straightedges or mechanical floats can induce surface waves.</p>  | <p>Mechanical oscillating floats will likely induce repetitive features on the pavement surface. Comparing the profile across the pavement (i.e., from left to right wheelpaths) combined with filtered profiles and PSD plots can help to identify this feature.</p> <p>In addition, real-time measurements before and after the mechanical floats/hand finishers can help assess the effects of finishing.</p> <p>Chapter 2 presented an example of how real-time measurements before and after hand finishers can be used to assess finishing operation effects.</p> | <p>Limit the amount of hand and mechanical finishing to only where the surface exhibits voids or imperfections.</p> <p>Address segregation, workability, and ease of finishing in the mix design to minimize the amount of hand/mechanical finishing.</p>  |

<sup>a</sup> JRCP = jointed reinforced concrete pavement.

## CHAPTER 4

# Conclusions and Summary of Recommendations

### Conclusions

Throughout the duration of this project, the research team assembled a large amount of information and field data and worked closely with the technology vendors and paving contractors. The following points highlight the key conclusions from this work:

- Numerous real-time smoothness measuring technologies were reviewed during Phase 1, and two of these technologies were recommended for evaluation in Phase 2:
  1. GOMACO Smoothness Indicator (GSI); and
  2. Ames Engineering Real Time Profiler (RTP).
- Additional technologies were reviewed but not recommended for evaluation during this project because they lacked technical maturity and/or a proven history on concrete paving applications.
- Recommendations for broad and specific enhancements for these technologies were presented in Chapter 2. Note that refinements to the Ames Engineering RTP were accomplished during Phase 3 to address the operational issues described in Chapter 2.
- A draft model specification to conduct real-time smoothness measurements during construction of concrete pavements was developed and is presented in Appendix H. Note that the most logical place to use the model specification developed under this effort is as part of a QMP and not directly in the project specifications.
- A summary of objectionable profile characteristics and better practice guidelines to prevent them was outlined based on the detailed documentation gathered throughout the project and presented in Chapter 3.
- Both real-time profilers demonstrated adequate performance as tools for construction quality control during the field evaluation (Phase 2) and subsequent field demonstrations (Phase 3).
- Conversely, these technologies demonstrated they are not suitable for quality assurance devices or for calculation of pay adjustments for smoothness.
- The mounting of the real-time profiling equipment is still an issue, especially for pavers that use an OCB behind a dowel bar inserter. On the basis of the New York technology demonstration, it can be seen that the alternative of using a self-propelled work bridge appears to be an improvement over mounting behind an OCB. This approach, however, is only viable when the track line for the work bridge is relatively smooth.
- An additional mounting-related issue was the initial concern that contractors experience when adding another machine or work bridge to the paving train. This concern appears to disappear once they realize the potential of this technology to identify and diagnose smoothness-related problems.
- To get the most from the real-time profiles, a few simple analyses can be performed (see Chapter 2). The most benefit can be yielded when more than one profile is available for the same pavement. This can include
  - Simultaneous real-time profiles of adjacent lanes or wheelpaths;
  - Simultaneous real-time profiles along the same line, but at different positions in the paving process (e.g., paver mounted compared to behind the hand finishers, on a bridge-mounted device); and
  - Real-time profiles compared to hardened concrete profiles collected using other means (e.g., lightweight or high-speed profilers).
- The latter option is probably the most practical one and has the additional benefit of comparing the real-time profiler to a measurement that is possible for use in QA.

### Summary of Recommendations

During the Phase 3 technology demonstrations, it was noted that there was consensus among the contractors that the real-time smoothness measuring technology represents a valuable

quality control tool. Not surprisingly, a difference of opinion on how the technology should be implemented was also noted. Some of the contractors focused on identifying bumps and dips in real time with the GSI and RTP or were periodically looking at the screen and noting the smoothness statistic (IRI). Other contractors were most interested in monitoring the effects of making paving equipment and process adjustments. Both approaches have merit, but after the detailed evaluation and demonstration of the two technologies involved in this study, it appears that the ability to have real-time feedback from intentional process changes has the potential to make lasting improvements in the smoothness of concrete pavements.

Examples of intentional process changes that can be evaluated with real-time smoothness measuring equipment include

- Equipment adjustments
  - Paving speed;
  - Vibrator frequency;
  - Sensitivity of paver elevation controls;
  - Oscillating correcting beam frequency; and
  - Numerous others.
- Process changes
  - Concrete workability;
  - Concrete dumping and spreading procedures;
  - String line tension;
  - Hand-finishing techniques;
  - Mixing time;
  - Stopping the paver versus slowing the paver; and
  - Numerous others.

Although all of these items fit under the umbrella of quality assurance, it may be misleading to only refer to real-time profilers as a quality control tool. It is a powerful diagnostic tool, similar to the equipment used by automotive technicians to identify needed auto repairs. The current state of the practice is to cautiously make an equipment or process change and wait approximately 24 h for feedback when the hardened pavement can be profiled.

The following sections present recommendations for further preimplementation activities to build on the process monitoring benefits described above and the quality control benefits presented throughout this report.

### Training and Outreach Materials

The research team's first recommendation is related to using real-time smoothness technologies as a training tool for paving crews. As noted earlier in Chapter 2, the research team noticed that several members of the paving crew, particularly the paving superintendent, continuously monitored the



**Figure 4.1. Paving superintendent interacting with the GSI display on the side of the paver.**

smoothness statistic displayed by one of the real-time devices (see Figure 4.1).

One anecdote noted by the research team is that at some point during the field evaluation, dry concrete loads were spotted by the spreader operator and the contractor began to reject them. When this happened, the paver operator intuitively began to monitor the effects of the dry loads and subsequent adjustments at the concrete plant on the smoothness statistic. The paver operator also expressed that it would be beneficial for the crew to locate the real-time profiler display on top of the paver next to the paver operator, instead of on the side of the paver, as during the field evaluation. This would allow the paver operator to understand the effect on smoothness from actions such as strike-off plate adjustments and auger usage. Because the paver operator communicates closely with the spreader operator, and both of them are aware of visual changes of concrete mix quality and consistency, having the real-time display in clear view would allow them to relate concrete mix changes or delivery issues to smoothness.

On the basis of these observations, the research team identified the potential for developing training and outreach materials in the form of an interactive DVD or website using the video and photographic documentation from the field evaluation conducted during Phase 2 and the field demonstrations conducted during Phase 3. These videos showcase real-time smoothness technologies, their feedback, and how the feedback relates to the paving operation, subsequent activities, and ultimately smoothness requirements and specifications. These materials should be targeted to concrete paving contractors but would also be of interest to pavement engineers and designers, construction inspectors, and paving equipment manufacturers.

In addition, it is recommended to prepare supplementary materials to highlight the need for better field practices and operations as documented throughout the field evaluation and demonstrations and summarized in Table 3.1. It is recommended to create a quick field reference card or booklet to readily disseminate the information in this summary table, for users to quickly identify common objectionable profile characteristics and address them in real time. Finally, the team recommends using easy access web tools such as YouTube and Flickr to reach as many stakeholders as possible.

## Workshops

Similarly, the research team identified the potential value for developing training materials for targeted workshops that address concrete pavement smoothness specifications and guidelines. The workshop materials may be partly based on documentation from the field evaluation conducted during Phase 2 and the field demonstrations during Phase 3, which comprise varied projects around the nation with different contractors, paving equipment, pavement types, and so forth. The control of smoothness in real time is to be showcased, but the workshops are to highlight better practices and means to enhance state highway agency practices to improve smoothness. Pilot workshops should be conducted and materials adapted as needed to best meet agency and regional needs. These workshops should be targeted to pavement engineers and designers, construction inspectors, and paving contractors.

## Real-Time Smoothness Equipment Loan Program

The research team identified the potential for a Real-Time Smoothness Equipment Loan Program, possibly as part of a SHRP 2 implementation activity. Such a program would allow further field evaluation and demonstration of this technology. There would be an opportunity to address outstanding issues, particularly the mounting of the real-time profiling equipment, as noted during the field demonstration in New York (Chapter 2) and the conclusions presented earlier in this chapter.

In addition, throughout this report, anecdotes from the field evaluation and demonstrations were documented to illustrate the profile characteristics that have an impact on smoothness, including string line effects, stringless guidance system operation effects, dowel basket and reinforcement steel effects, localized roughness, and finishing effects. This information was

summarized in Table 3.1, and additional field evaluations and demonstrations will provide the opportunity to further investigate and possibly expand this list.

In following the model for similar equipment loan programs (e.g., FHWA), this activity could allow state DOTs and other owner-agencies to use and evaluate these technologies on their projects at minimal cost. Technical assistance could be provided to participating agencies to assure that the lessons learned in the original study are considered when implementing the technology on future projects. From the equipment demonstration, supplementary reports could be prepared and added to a “knowledge base” from which interested agencies can make more informed decisions about the viability of this technology on their projects. This knowledge base can possibly be maintained on the SHRP 2 website, on a current industry reference site (e.g., SmoothPavements.com), or as a dedicated website (e.g., RealTimeSmoothness.com).

## Real-Time Smoothness Knowledge-Based System

Another recommendation is related to the current availability and adequacy of the data processing software. The research team identified the need to expand on real-time profiler data analysis to take full advantage of the benefits associated with these technologies. The research team outlined the following framework for the development of this expert system:

1. The proposed system will contain a tool for interpreting real-time smoothness data analysis and will be able to handle data from the different equipment vendors (similar to the ProVAL software). The research team has learned that some systems feature alarms for bumps (localized roughness). Although this is helpful, the proposed package will expand this concept to a more useful diagnostic tool by identifying additional objectionable profile characteristics, particularly those that are repeating in nature.
2. The proposed system will require more information from the operator. It will “ask questions” that relate possible construction and paving activities to the objectionable profile characteristics being interpreted from the real-time smoothness measurements.
3. The proposed system will provide critical information to the operator to help identify activities, guidelines, and better practices that control and correct the smoothness issues that are being detected.
4. The proposed system can even use a “smartphone” application for “on the fly” changes as a real-time application.



## References

- Cable, J. K., S. M. Karamihas, M. Brenner, M. Leichty, T. Tabbert, and J. Williams. 2005. *Measuring Pavement Profile at the Slip-Form Paver*. Report FHWA DTFH61-01-X-00042 (Project 12). Center for Portland Cement Concrete Pavement Technology, Iowa State University, Ames.
- GOMACO Corporation. 2007. *GOMACO World*, Vol. 35, No. 2.
- GOMACO Corporation. 2008. *GOMACO Smoothness Indicator (GSI) ASAP Smoothness Readings*. GSI Brochure.
- Grogg, M. G., and K. D. Smith. 2001. *PCC Pavement Smoothness: Characteristics and Best Practices for Construction*. Applied Pavement Technology, Inc., Champaign, Ill.
- Karamihas, S. M. 2004. The 2004 FHWA Profiler Round-Up. Presented at the 2004 Road Profiler Users Group Meeting, Stateline, Nev.
- Karamihas, S. M. 2005. *Critical Profiler Accuracy Requirements*. Report UMTRI 2005-24. The University of Michigan Transportation Research Institute, Ann Arbor.
- Perera, R. W., S. D. Kohn, and C. R. Byrum. 2009 (Feb.). *Smoothness Criteria for Concrete Pavements*. Soil and Materials Engineers, Inc., Plymouth, Mich.
- Taylor, P. C., S. H. Kosmatka, G. F. Voigt, et al. 2007. *Integrated Materials and Construction Practices for Concrete Pavement: A State-of-the-Practice Manual*. Report FHWA HIF-07-004. National Concrete Pavement Technology Center/Center for Transportation Research and Education, Iowa State University, Ames.
- Virginia Tech. 2008. *Vehicle Terrain Performance Laboratory-Vehicle Terrain Measurement System*. Danville, Va.
- Walker, R., and E. Fernando. 2007. *Pilot Implementation of Bump Detection Profiler*. Report FHWA/TX-08/5-4385-01-1. University of Texas at Arlington, Texas Transportation Institute.

## APPENDIX A

## Phase 2—Field Evaluation: Paving Process Overview

Appendix A presents additional information regarding the test section along I-75 in Adel, Georgia, for the Phase 2 Field Evaluation. More details regarding the paving operation, including photographs, are provided.

Figure A.1 shows the typical section for the northbound lanes under construction during the field evaluation in Phase 2.

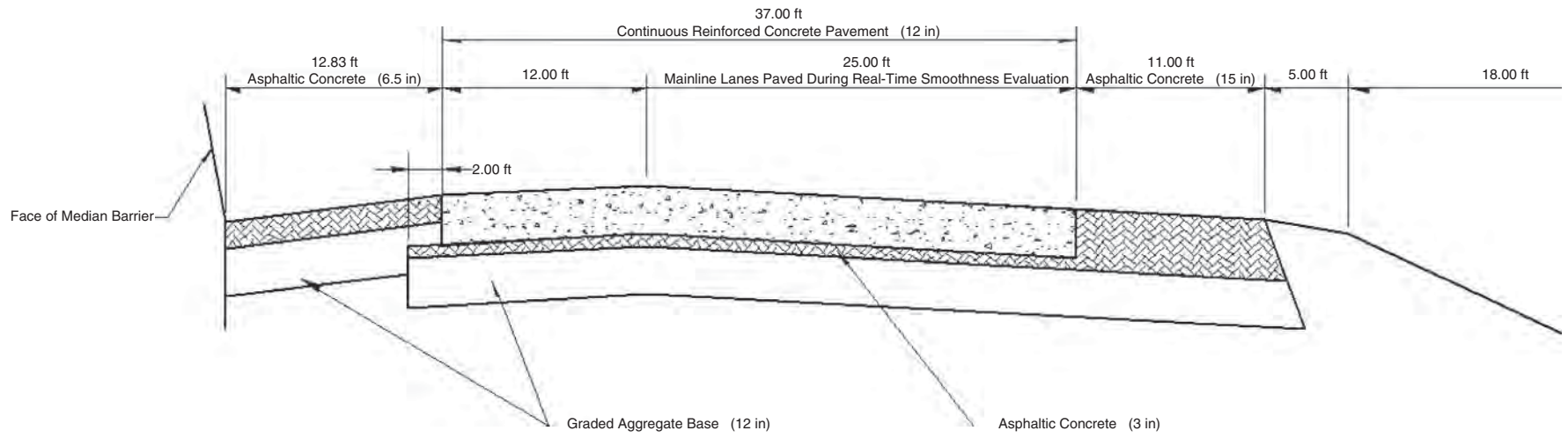
Concrete was produced from a central mix batch plant located near the south end of the project (Figure A.2). Mixing times of approximately 90 s for a batch size of 9 yd<sup>3</sup> were observed by the research team. The concrete mixture was transported in nonagitating dump trucks. Typical haul times from the plant site to the paving operation were approximately 10 to 15 min.

Concrete from the dump trucks was spread via a GOMACO PS 2600 belt placer/spreader (Figure A.3). Consolidation and initial finishing of the pavement were accomplished with a GOMACO GHP 2800 slipform paver (Figure A.4). Internal hydraulic vibrators on the paver were placed at approximately 6 in. from the pavement edge and then subsequently spaced at approximately 16 in. on-center across the width of the pavement being placed. Contractor personnel reported that the vibrators were normally operated at 8,500 vibrations per minute.

At the time of the field evaluation, a Leica stringless guidance system was used on the GOMACO GHP 2800 slipform paver. Figure A.5 shows that total stations in the right (outside) shoulder, along with prisms, slope sensors (not visible in the photograph), and the Leica machine computer mounted on the paver, work together to control the steering and elevations of the paver.

Hand finishing of the pavement behind the paver was performed using 12-ft straightedges to fill any surface voids; smoothness was checked with a 20-ft straightedge. When surface corrections were necessary, they were made with the 12-ft straightedges and final finishing was then performed with the 20-ft straightedge; a combination of hand-finishing tools was used for final finishing of the pavement edges (Figure A.6). A burlap drag was used behind the hand finishing, providing texture to the pavement surface (Figure A.7).

A transverse tined texture (nominally 0.5-in. spacing) was applied to the pavement surface with a GOMACO T/C 600 texture/cure machine (Figure A.8). This operation typically followed approximately 45 to 60 min behind the paving operations. Thus curing compound was applied to the pavement surface before any significant surface evaporation could occur (Figure A.9).



**Figure A.1. Typical section for I-75 Northbound paving.**



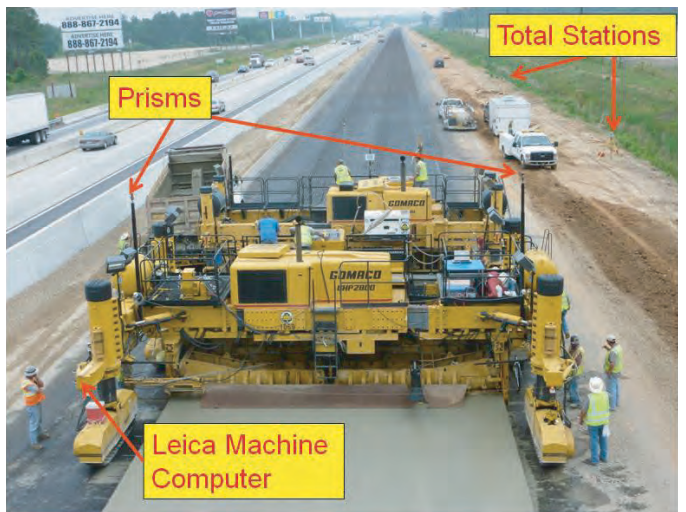
**Figure A.2.** Central mix batch plant used for paving I-75 Northbound.



**Figure A.3.** Front view of GOMACO PS 2600 belt placer/spreader.



**Figure A.4.** Front view of GOMACO GHP 2800 slipform paver.



**Figure A.5.** Leica stringless guidance system.





**Figure A.6.** Rear view of GOMACO GHP 2800 slipform paver and hand finishing.



**Figure A.7.** Burlap drag behind hand finishers.



**Figure A.8.** Transverse tining.



**Figure A.9.** Curing compound applied.

## APPENDIX B

# Phase 2—Field Evaluation: Hardened Pavement Profile Measurement Experiment

Appendix B provides details about repeatability and accuracy testing of the real-time profilers that participated in Phase 2 of the study. The profile measurements were conducted on hardened pavement on Wednesday (May 12, 2010). The use of a hardened pavement section permitted the collection of reference profile measurements with a low-speed device that contacted the pavement, as well as repeat profile measurements by the real-time devices on a stable surface.

The measurements covered a 1,000-ft-long area of pavement from Station 493+00 through Station 503+00, which was paved on Monday (May 10). Because the section was paved 2 days earlier, it was already textured and included a longitudinal saw cut between lanes. It was also sufficiently set to permit light vehicle traffic, although the only vehicle that traversed the pavement for the experiment was an inertial profiler operated by the Georgia Department of Transportation (Georgia DOT). Longitudinal profiles were measured in two lateral positions, shown in Figure B.1. The left lane profiles were collected 3 ft to the left of the longitudinal saw cut, near the left wheelpath. The right lane profiles were collected 7 ft to the left of the right pavement edge, near the lane center.

For guidance, the pavement was marked with a chalk line along each track of interest, and transverse marks were placed at Stations 493+00, 498+00, and 503+00. In some cases, profile measurements covered the entire 1,000 ft. In other cases, one device measured profile over the first 500 ft while the other device measured profile over the second 500 ft. This helped other crews remain productive on one-half of the pavement while the GOMACO work bridge covered the other half. The analyses described below were applied over the entire length of the section whenever it was possible, then repeated using all of the measurements that covered the first half of the section and using all of the measurements that covered the second half of the section.

An auto broom passed over both lanes before the measurements began. In addition, members of the field crew cleaned both wheelpaths of interest by scraping them with a shovel

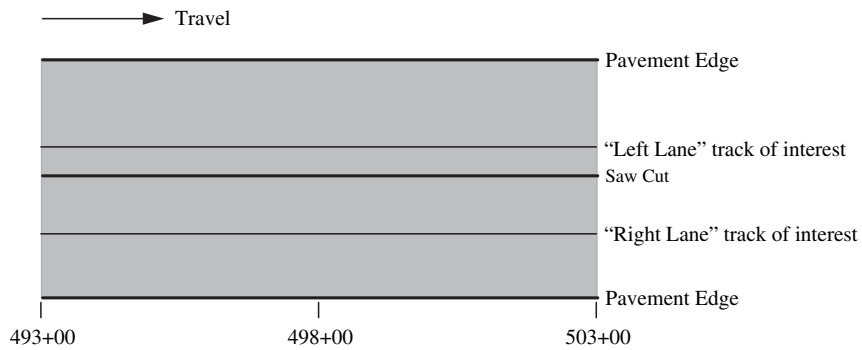
and removing loose chunks of hardened concrete, dust, and debris with a hand broom.

Four profilers conducted measurements on the hardened pavement section: (1) a SurPRO 2000, (2) an International Cybernetics Corporation (ICC) inertial profiler with point lasers, (3) two GOMACO Smoothness Indicator (GSI) units connected to a work bridge, and (4) an Ames Engineering Real Time Profiler (RTP). The SurPRO 2000 served as the reference profiler for this experiment. It covered each wheelpath over the entire 1,000 ft and conducted repeat measurements in each lane over 500 ft. The repeat measurements helped assess the efficacy of using the device as a reference profiler.

The ICC inertial profiler measured each wheelpath over the entire length of the section three times. These measurements provided a sanity check on the reference measurements and an example of the level of repeatability and agreement to the reference measurement that may be expected out of a common inertial profiler. Each real-time profiler measured each wheelpath over the entire length of the section. The GOMACO GSI conducted repeat measurements over the second half of the section, and the Ames Engineering RTP conducted repeat measurements in the right lane over the first 500 ft of the section.

The remainder of this appendix lists the details of the measurement program, repeatability and accuracy statistics, and pertinent observations made during the analysis for each device. This includes the following:

- Profiler make, profiler model, owner, and operator, if known;
- Low-pass filtering, with a judgment on whether the 250-mm moving average is necessary when calculating the international roughness index (IRI) or if it would be redundant;
- A profile measurement log;
- IRI values;
- A repeatability score based on cross correlation of profile between repeat measurements;



**Figure B.1. Wheelpaths of interest.**

- An accuracy score based on cross correlation of profile between a candidate device and the reference measurement;
- Narrative to augment the measurement log; and
- Special observations that either help explain the repeatability and accuracy statistics or other phenomena of interest to the study.

The repeatability and accuracy scores are often the average of all of the possible comparisons. For example, three repeat profile measurements from a candidate profiler yield three comparisons for a reference profile, and three combinations of repeat measurements (1–2, 1–3, and 2–3). The special observations include a note if any one of the repeat measurements stands out as lacking in agreement to the others.

Cross correlation was performed only after filtering the profile to emphasize a given waveband of interest. To do this, the two profiles under comparison passed through the same filter before the output traces were cross correlated. This included four wavebands:

1. IRI: The same filters used in the IRI algorithm were applied. These filters produced a trace that included profile features in proportion to their effect on the IRI.
2. Long waveband: This is a band-pass filter with a long wavelength cutoff of 131 ft (40 m) and a short wavelength cutoff of 26.2 ft (8 m).
3. Medium waveband: This is a band-pass filter with a long wavelength cutoff of 26.2 ft (8 m) and a short wavelength cutoff of 5.25 ft (1.6 m).
4. Short waveband: This is a band-pass filter with a long wavelength cutoff of 5.25 ft (1.6 m) and a short wavelength cutoff of 1.05 ft (0.32 m).

Items 2 to 4 used the same 6th-order Butterworth filters provided in ProVAL, except that the profile was converted to slope before the filter was applied. This helped maintain a reasonably even distribution of content within the pass-band of each filter. Ultimately, cross correlation in the IRI waveband is considered the most relevant judgment of agreement between profiles. Cross correlation in the other wavebands provides diagnostic information.

Several details of the signal processing require careful consideration to ensure the relevance of the results. This study used calculation procedures that were identical to those used in the Benchmark Profiler Experiments conducted under Pooled Fund Study TPF-5(063), “Improving the Quality of Pavement Profile Measurement.”

A critical aspect of the approach is that cross-correlation values are reported after the inconsistencies in longitudinal offset and longitudinal distance measurement are removed. In addition, short waveband repeatability and accuracy scores were derived using 105-ft-long segments of profile spread out throughout the test section. This helped minimize the confounding effect of small (nonlinear) errors in longitudinal distance measurement.

### Profiler Evaluation Report #1

Device: SurPRO 2000  
 Operator: Buzz Powell  
 Date: 12-May-2010  
 Test Section: Scruggs/I-75, 493+00–503+00  
 Recording Interval: 1 in.  
 Use Moving Average: No

The layout of the device imposes an analog filter equivalent to a 250-mm moving average through a mechanism called “wheelbase filtering.”

Up-Sampling: Data were up-sampled to an interval of 5.08 mm for repeatability analysis.

Run Log:

| Run | Lane  | Time  | Range         |
|-----|-------|-------|---------------|
| 1   | Right | 12:40 | 503+00–493+00 |
| 2   | Left  | 13:00 | 493+00–498+00 |
| 3   | Left  | 13:15 | 498+00–493+00 |
| 4   | Left  | 13:25 | 493+00–503+00 |
| 5   | Right | 13:38 | 503+00–498+00 |
| 6   | Right | 13:48 | 498+00–503+00 |

## IRI Values:

| Run | Lane  | Start  | End    | IRI (in./mi) |
|-----|-------|--------|--------|--------------|
| 1   | Right | 493+00 | 503+00 | 52           |
| 1   | Right | 493+00 | 498+00 | 50           |
| 1   | Right | 498+00 | 503+00 | 52           |
| 5   | Right | 498+00 | 503+00 | 51           |
| 6   | Right | 498+00 | 503+00 | 52           |
| 4   | Left  | 493+00 | 503+00 | 50           |
| 2   | Left  | 493+00 | 498+00 | 47           |
| 3   | Left  | 493+00 | 498+00 | 48           |
| 4   | Left  | 493+00 | 498+00 | 47           |
| 4   | Left  | 498+00 | 503+00 | 53           |

## Cross-Correlation Results:

| Lane                  | Right         | Left          |
|-----------------------|---------------|---------------|
| Range                 | 493+00–498+00 | 498+00–503+00 |
| Number of runs        | 3             | 3             |
| Repeatability scores: |               |               |
| IRI waveband          | 0.93          | 0.93          |
| Long waveband         | 0.95          | 0.96          |
| Medium waveband       | 0.93          | 0.93          |
| Short waveband        | 0.40          | 0.46          |

## Notes:

- Repeatability scores include three comparisons (for three runs) over the first half of the test section in the right lane and three comparisons (for three runs) over the second half of the test section in the left lane.
- One of the comparison runs for repeatability for each lane was extracted by cropping a run that covered the entire length of the test section (Runs 1 and 4).

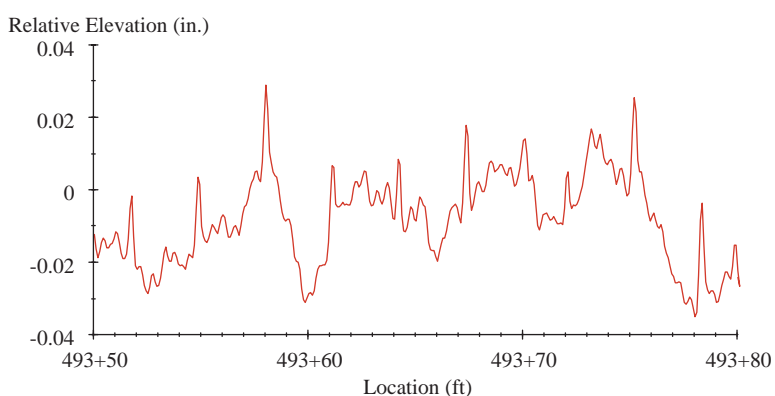
## Special Observations:

- Longitudinal distance measurements were consistent with the test section layout.
- The SurPRO 2000 detected narrow bumps throughout the test section, often with a consistent spacing of 3 ft. This corresponds to the spacing of transverse reinforcing bars in the pavement. The most likely explanation for this is rebound of the bars, causing “reinforcement ripple” at the surface. The figures below provide an example of the effect of the bumps.
- The first plot, Figure B.2, shows a short segment of the right lane elevation profile. The profile was processed with a high-pass filter using a cutoff wavelength of 50 ft. (This removes the grade and makes shallow, short-duration features more visible.)
- The second plot, Figure B.3, shows the power spectral density (PSD) for the right lane profile over the entire 1,000-ft section. The narrow spikes in plot at 3 ft, 1.5 ft, and to a lesser extent 6 ft indicate content in the profile isolated at those wavelengths. The content was not isolated exclusively at 3 ft, because the pattern established by the bumps did not appear with a sinusoidal shape.

## Profiler Evaluation Report #2

Device: ICC high-speed profiler, small footprint height sensor  
 Operator: Georgia DOT  
 Date: 12-May-2010  
 Test Section: Scruggs/I-75, 493+00–503+00  
 Recording Interval: 1.30787 in.  
 Use Moving Average: Yes

A low-pass filter was applied when the file was converted to ERD format. The cutoff wavelength is sufficiently short that the 250-mm moving average is not redundant.



**Figure B.2. Short segment of the right lane elevation profile.**



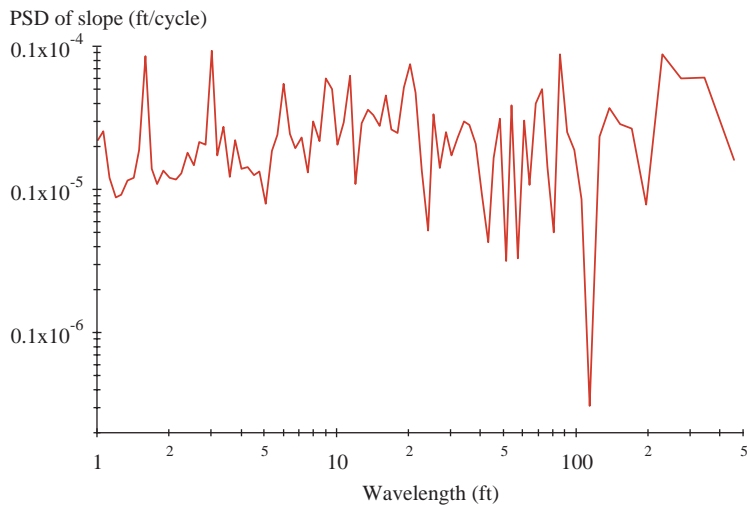


Figure B.3. PSD for the right lane (SurPRO 2000).

Up-Sampling: Data were up-sampled to an interval of 5.08 mm for repeatability analysis and comparison to the reference profiles.

Run Log:

| Run | Lane  | Time  | Range         |
|-----|-------|-------|---------------|
| 1   | Left  | 15:08 | 493+00–503+00 |
| 2   | Left  | 15:11 | 493+00–503+00 |
| 3   | Left  | 15:13 | 493+00–503+00 |
| 4   | Right | 15:18 | 493+00–503+00 |
| 5   | Right | 15:19 | 493+00–503+00 |
| 6   | Right | 15:21 | 493+00–503+00 |

IRI Values:

| Start  | End    | Run | Right Lane IRI (in./mi) | Run | Left Lane IRI (in./mi) |
|--------|--------|-----|-------------------------|-----|------------------------|
| 493+00 | 503+00 | 4   | 50                      | 1   | 48                     |
|        |        | 5   | 50                      | 2   | 48                     |
|        |        | 6   | 51                      | 3   | 49                     |
| 493+00 | 498+00 | 4   | 49                      | 1   | 47                     |
|        |        | 5   | 50                      | 2   | 46                     |
|        |        | 6   | 51                      | 3   | 47                     |
| 498+00 | 503+00 | 4   | 49                      | 1   | 49                     |
|        |        | 5   | 49                      | 2   | 49                     |
|        |        | 6   | 50                      | 3   | 51                     |

Repeatability Results:

| Lane                  | Right         | Left          |
|-----------------------|---------------|---------------|
| Range                 | 493+00–503+00 | 493+00–503+00 |
| Number of runs        | 3             | 3             |
| Repeatability scores: |               |               |
| IRI waveband          | 0.93          | 0.91          |
| Long waveband         | 0.94          | 0.95          |
| Medium waveband       | 0.93          | 0.91          |
| Lane                  | Right         | Left          |
| Range                 | 493+00–498+00 | 493+00–498+00 |
| Number of runs        | 3             | 3             |
| Repeatability scores: |               |               |
| IRI waveband          | 0.95          | 0.89          |
| Long waveband         | 0.97          | 0.97          |
| Medium waveband       | 0.95          | 0.90          |
| Short waveband        | 0.62          | 0.40          |
| Lane                  | Right         | Left          |
| Range                 | 498+00–503+00 | 498+00–503+00 |
| Number of runs        | 3             | 3             |
| Repeatability scores: |               |               |
| IRI waveband          | 0.91          | 0.93          |
| Long waveband         | 0.91          | 0.93          |
| Medium waveband       | 0.90          | 0.93          |
| Short waveband        | 0.53          | 0.48          |

## Accuracy Results:

| Lane             | Right         | Left          |
|------------------|---------------|---------------|
| Range            | 493+00–503+00 | 493+00–503+00 |
| Number of runs   | 3             | 3             |
| Accuracy scores: |               |               |
| IRI waveband     | 0.88          | 0.87          |
| Long waveband    | 0.81          | 0.76          |
| Medium waveband  | 0.89          | 0.90          |

---

| Lane             | Right         | Left          |
|------------------|---------------|---------------|
| Range            | 493+00–498+00 | 493+00–498+00 |
| Number of runs   | 3             | 3             |
| Accuracy scores: |               |               |
| IRI waveband     | 0.90          | 0.88          |
| Long waveband    | 0.86          | 0.83          |
| Medium waveband  | 0.92          | 0.87          |
| Short waveband   | 0.59          | 0.28          |

---

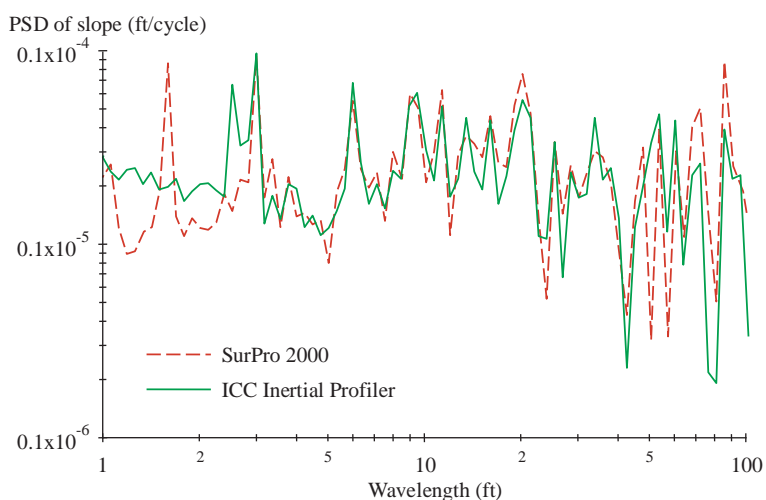
| Lane             | Right         | Left          |
|------------------|---------------|---------------|
| Range            | 498+00–503+00 | 498+00–503+00 |
| Number of runs   | 3             | 3             |
| Accuracy scores: |               |               |
| IRI waveband     | 0.87          | 0.84          |
| Long waveband    | 0.78          | 0.72          |
| Medium waveband  | 0.87          | 0.87          |
| Short waveband   | 0.55          | 0.20          |

## Notes:

- The native low-pass filter appears to be a moving average with a base length equal to twice the recording interval.
- In all runs, the operator passed the right-side sensors (height sensor and accelerometer) over the wheelpath of interest. Data from the left-side sensors were not processed, because they did not pass over any wheelpath covered by other profilers. (For the “right wheelpath” runs, the left sensor set passed over the saw cut.)
- Repeatability and accuracy scores are the average of three comparisons (for three runs).
- The profiler collected an extra 50 ft of profile after station 503+00. This portion of the profiles was ignored.
- All data that cover only half of the section were extracted (cropped) from runs over the entire section.
- Accuracy scores were derived using comparison to runs 1 and 4 from the SurPRO 2000.

## Special Observations:

- The ICC inertial profiler measured longitudinal distance that was about 2% shorter than the SurPRO 2000. The analysis sought the optimal adjustment to longitudinal distance before calculating an accuracy score.
- Accuracy and repeatability in the long waveband were below the level that was expected. This is most likely caused by the relatively slow (25 to 30 mph) speed of operation of the profiler.
- Through most of the range that affects the IRI, agreement in spectral content between the ICC inertial profiler and the SurPRO 2000 was good, as shown in Figure B.4. The



**Figure B.4. PSD (Georgia DOT ICC Inertial Profiler and SurPRO 2000).**

spectral content agreed particularly well in the wavelength range from 3 ft to 50 ft. The agreement level in the medium waveband could not have been achieved otherwise.

- Despite the difference in their underlying technology, both profilers detected the content isolated at wavelengths of 3 ft and 6 ft about equally. This confirms that the roughness was most likely caused by a feature in the road, rather than a measurement artifact. In contrast, the inertial profiler detected some roughness at a wavelength of about 2.5 ft that the SurPRO 2000 did not.
- The SurPRO 2000 detected isolated content at a wavelength of 1.5 ft that the ICC inertial profiler did not. This is most likely caused by a disagreement between the profilers in the shape of the repetitive roughness with a spacing of 3 ft.

### Profiler Evaluation Report #3

Device: GOMACO GSI, mounted to a work bridge  
 Operator: Mark Brenner, GOMACO  
 Date: 12-May-2010  
 Test Section: Scruggs/I-75, 493+00–503+00  
 Recording Interval: 2 in.  
 Use Moving Average: Yes

A low-pass filter was applied as part of the measurement process. The cutoff wavelength is sufficiently short that the 250-mm moving average is not redundant. The native low-pass filter appears to be a moving average with a base length equal to twice the recording interval.

Up-Sampling: Data were up-sampled to an interval of 5.08 mm for repeatability analysis and comparison to the reference profiles.

#### Run Log:

| Run | Lane | Time  | Range         |
|-----|------|-------|---------------|
| 1   | Both | 10:13 | 493+00–503+00 |
| 2   | Both | 12:05 | 498+00–503+00 |
| 3   | Both | 12:58 | 498+00–503+00 |

#### IRI Values:

| Run | Lane  | Start  | End    | IRI (in./mi) |
|-----|-------|--------|--------|--------------|
| 1   | Right | 493+00 | 503+00 | 67           |
| 1   | Right | 493+00 | 498+00 | 67           |
| 1   | Right | 498+00 | 503+00 | 68           |
| 2   | Right | 498+00 | 503+00 | 58           |
| 3   | Right | 498+00 | 503+00 | 60           |

#### IRI Values (*continued*):

| Run | Lane | Start  | End    | IRI (in./mi) |
|-----|------|--------|--------|--------------|
| 1   | Left | 493+00 | 503+00 | 48           |
| 1   | Left | 493+00 | 498+00 | 46           |
| 1   | Left | 498+00 | 503+00 | 50           |
| 2   | Left | 498+00 | 503+00 | 51           |
| 3   | Left | 498+00 | 503+00 | 53           |

#### Repeatability Results:

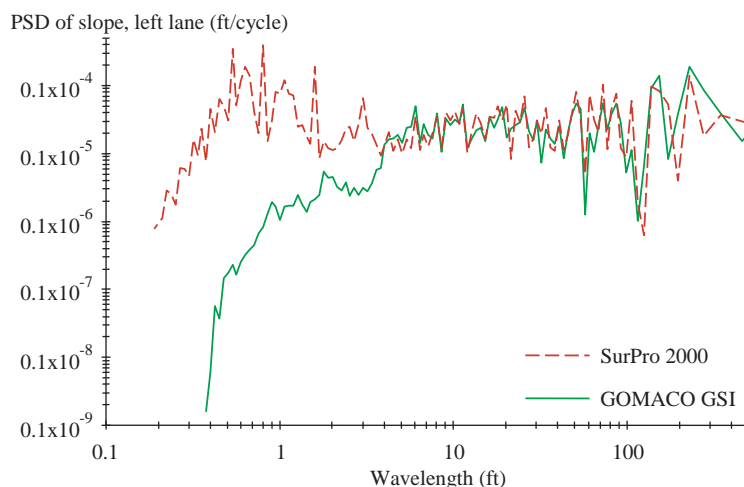
| Lane                  | Right         | Left          |
|-----------------------|---------------|---------------|
| Range                 | 498+00–503+00 | 498+00–503+00 |
| Number of runs        | 3             | 3             |
| Repeatability scores: |               |               |
| IRI waveband          | 0.63          | 0.87          |
| Long waveband         | 0.69          | 0.81          |
| Medium waveband       | 0.62          | 0.88          |
| Short waveband        | 0.25          | 0.54          |

#### Accuracy Results:

| Lane             | Right         | Left          |
|------------------|---------------|---------------|
| Range            | 493+00–503+00 | 493+00–503+00 |
| Number of runs   | 1             | 1             |
| Accuracy scores: |               |               |
| IRI waveband     | 0.49          | 0.85          |
| Long waveband    | 0.51          | 0.76          |
| Medium waveband  | 0.48          | 0.88          |

| Lane             | Right         | Left          |
|------------------|---------------|---------------|
| Range            | 493+00–498+00 | 493+00–498+00 |
| Number of runs   | 1             | 1             |
| Accuracy scores: |               |               |
| IRI waveband     | 0.44          | 0.84          |
| Long waveband    | 0.53          | 0.80          |
| Medium waveband  | 0.43          | 0.85          |
| Short waveband   | 0.16          | 0.08          |

| Lane             | Right         | Left          |
|------------------|---------------|---------------|
| Range            | 498+00–503+00 | 498+00–503+00 |
| Number of runs   | 3             | 3             |
| Accuracy scores: |               |               |
| IRI waveband     | 0.62          | 0.85          |
| Long waveband    | 0.59          | 0.76          |
| Medium waveband  | 0.62          | 0.87          |
| Short waveband   | 0.18          | 0.07          |



**Figure B.5. PSD (GOMACO GSI and SurPRO 2000).**

Notes:

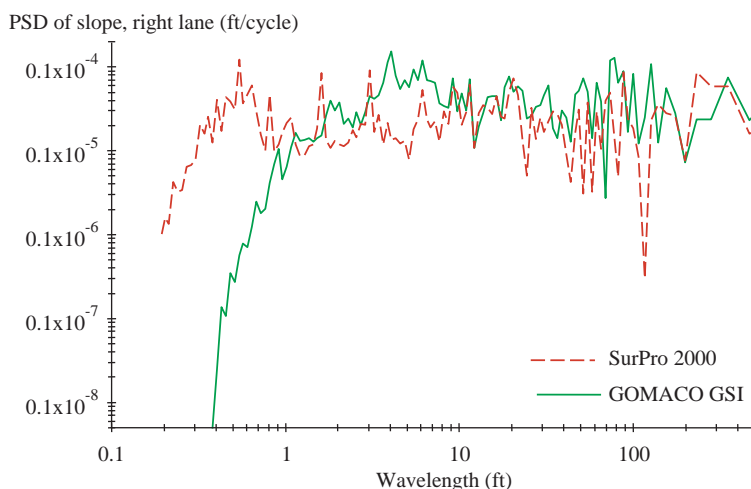
- Repeatability scores include three comparisons (for three runs) in the right lane and three comparisons (for three runs) in the left lane.
- One of the comparison runs for repeatability for each lane was extracted by cropping a run that covered the entire length of the test section (using Run 1).

Special Observations:

- Repeatability in the right lane was much lower than in the left lane. This is attributable in part to a large disturbance that appeared in Run 1 only from 499+20 to 499+30. The repeatability score for the other two runs in the IRI waveband is about 0.70.
- IRI values measured in the left lane agreed well with the SurPRO 2000 (50 in./mi versus 48 in./mi for the entire section). The PSD plot in Figure B.5 shows that the spectral

content for the left lane agrees well with the SurPRO 2000 in the wavelength range from 4 to 50 ft. However, the content measured by the GSI unit drops off compared to the SurPRO 2000 by an order of magnitude or more for most of the wavelength range below 4 ft. (This is an artifact of the sensor arrangement.) In addition, the GSI did not detect the strong content in the profile with a characteristic wavelength of 3 ft.

- IRI values measured in the right lane did not agree with the SurPRO 2000. For example, the SurPRO 2000 measured an average IRI of 52 in./mi over the entire section, whereas the GSI measured 67 in./mi. The other two repeat measurements over the second half of the section agreed better but still overestimated the IRI by 7 to 10 in./mi.
- The PSD plot in Figure B.6 shows that the spectral content for the right lane is higher in the GSI measurement than the SurPRO 2000 for the wavelength range from 2 ft up to about 10 ft. Again, the GSI did not detect the strong content in the profile with a characteristic wavelength of 3 ft.



**Figure B.6. PSD (GOMACO GSI and SurPRO 2000).**



**Profiler Evaluation Report #4**

Device: Ames Engineering RTP  
 Operator: Ames Engineering  
 Date: 12-May-2010  
 Test Section: Scruggs/I-75, 493+00–503+00  
 Recording Interval: 2.995 in.  
 Use Moving Average: No

A low-pass filter was applied an inherent part of the measurement process related to the longitudinal sensor arrangement. The effective cutoff wavelength is sufficiently long that the 250-mm moving average is redundant.

Up-Sampling: Data were up-sampled to an interval of 5.08 mm for repeatability analysis and comparison to the reference profiles.

**Run Log:**

| Run | Lane  | Time        | Range         |
|-----|-------|-------------|---------------|
| 1   | Right | 12:00–14:00 | 493+00–503+00 |
| 2   | Left  | 12:00–14:00 | 503+00–493+00 |
| 3   | Right | 12:00–14:00 | 498+00–493+00 |
| 4   | Right | 12:00–14:00 | 493+00–498+00 |

**IRI Values:**

| Run | Lane  | Start  | End    | IRI (in./mi) |
|-----|-------|--------|--------|--------------|
| 1   | Right | 493+00 | 503+00 | 56           |
| 1   | Right | 493+00 | 498+00 | 61           |
| 1   | Right | 498+00 | 503+00 | 51           |
| 2   | Left  | 493+00 | 503+00 | 55           |
| 2   | Left  | 493+00 | 498+00 | 55           |
| 2   | Left  | 498+00 | 503+00 | 59           |
| 3   | Right | 493+00 | 498+00 | 60           |
| 4   | Right | 493+00 | 498+00 | 53           |

**Repeatability Results:**

| Lane                  | Right         |
|-----------------------|---------------|
| Range                 | 493+00–498+00 |
| Number of runs        | 3             |
| Repeatability scores: |               |
| IRI waveband          | 0.67          |
| Long waveband         | 0.31          |
| Medium waveband       | 0.86          |
| Short waveband        | 0.89          |

**Accuracy Results:**

| Lane             | Right         | Left          |
|------------------|---------------|---------------|
| Range            | 493+00–503+00 | 493+00–503+00 |
| Number of runs   | 1             | 1             |
| Accuracy scores: |               |               |
| IRI waveband     | 0.83          | 0.77          |
| Long waveband    | 0.17          | 0.31          |
| Medium waveband  | 0.91          | 0.86          |

| Lane             | Right         | Left          |
|------------------|---------------|---------------|
| Range            | 493+00–498+00 | 493+00–498+00 |
| Number of runs   | 3             | 1             |
| Accuracy scores: |               |               |
| IRI waveband     | 0.80          | 0.74          |
| Long waveband    | 0.33          | 0.24          |
| Medium waveband  | 0.91          | 0.73          |
| Short waveband   | 0.28          | 0.14          |

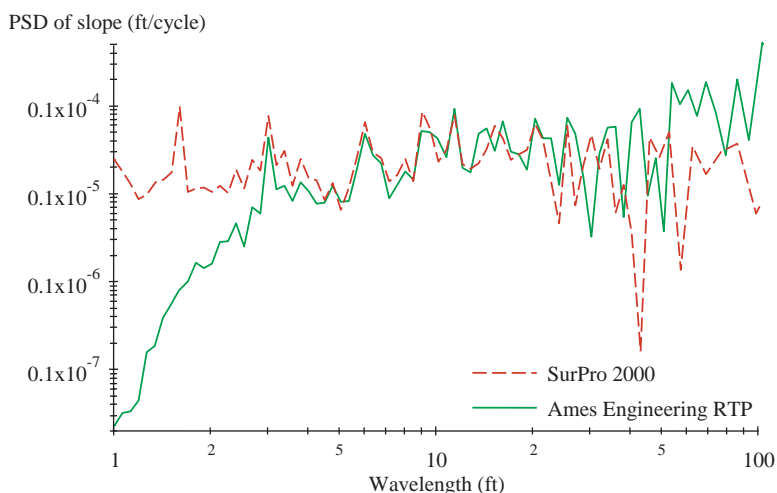
| Lane             | Right         | Left          |
|------------------|---------------|---------------|
| Range            | 498+00–503+00 | 498+00–503+00 |
| Number of runs   | 1             | 1             |
| Accuracy scores: |               |               |
| IRI waveband     | 0.86          | 0.76          |
| Long waveband    | 0.27          | 0.28          |
| Medium waveband  | 0.91          | 0.84          |
| Short waveband   | 0.31          | 0.09          |

**Notes:**

- Repeatability scores include three comparisons (for three runs) in the right lane over the first half of the section.
- Some comparison runs for accuracy over half-sections were extracted (cropped) from Runs 1 and 2.
- Raw profile data included parabolic drift that affected the apparent roughness at the section ends attributable to filter end effects. (This was the case even when the profiles were reflected at the ends to remove this, because of the aggressive curvature.) To mitigate this, cross correlations in the long, medium, and IRI wavebands were performed after cropping 100 ft of profile from the outer edges for the 500-ft-long sections and cropping 200 ft of profile from the outer edges of the 1,000-ft-long profiles.

**Special Observations:**

- Repeatability was very low in the long waveband and somewhat low in the IRI waveband, mainly because of the aggressive (artificial) curvature of the profile at the leading



**Figure B.7. PSD (Ames Engineering RTP and SurPRO 2000).**

end of the section. This effect was removed for accuracy evaluation.

- The RTP agreed best with the SurPRO 2000 in the medium waveband. The PSD plot in Figure B.7 shows that the spectral content for the right lane agrees well with the SurPRO 2000 in the wavelength range from 4 to 40 ft. However, the content measured by the RTP unit drops off compared to the SurPRO 2000 with decreasing wavelength and reaches a notch with very low response at a wavelength of 1 ft. (This is an artifact of the sensor arrangement.)
- The PSD plot shows that the RTP was able to detect the roughness isolated at 3 ft and 6 ft caused by reinforcement ripple, but the content at 3 ft was attenuated somewhat.
- IRI values measured in the left lane were 10% to 20% above those measured by the SurPRO 2000, and IRI values measured in the right lane were up to 20% above those measured by the SurPRO 2000. However, the distribution of roughness within each test section measured by the RTP was similar to the SurPRO 2000, in that both devices agreed on which areas included the most roughness.
- Low accuracy scores for the left lane profiles are attributed to “chatter” in the profiles, in which every other sample is elevated compared to the two samples around it. The plots have the same appearance as the plots produced when two interlaced profiles are meshed together that do not have equivalent drift.

## APPENDIX C

# Phase 2—Field Evaluation: Additional Information Regarding Data Collection Methods and Procedures

Table C.1 provides details regarding the sensors used to monitor paver vibrations and displacements during the field evaluation in Phase 2.

### RoboTex Measurement System

A robotic measurement system, RoboTex, was used to measure the macrotexture of the hardened pavement surface (see Figure C.1, left). The RoboTex system is built around a line laser sensor and fixed atop a remote-controlled robotic chassis, controlled by customized software. The laser manufacturer is LMI Technologies and the laser model is RoLine 1130.

In addition to the line laser, RoboTex incorporates a number of other sensors, including

- Accelerometer, to establish an inertial reference plane;
- Wheel encoder, to determine the position of the robot;
- Global Positioning System, to establish a global position of the robot for reference;
- Time, to determine speed and for global reference; and
- Digital video camera, for a visual record of the surface.

The system is capable of sampling more than 100 points across a 100-mm-wide laser line at 1,000 Hz as it travels down the road under its own power at approximately 1 mph. The result is a pavement texture measurement with a spatial resolution of about 0.4 mm<sup>2</sup> and a height resolution of 0.01 mm. More important, the result is a three-dimensional texture profile along a 100-mm-wide swath of pavement surface.

In addition to macrotexture measurements, RoboTex was used as a vehicle on which to mount the Ames Engineering Real Time Profiler (RTP) to measure the profile of the hardened surface (see Figure C.1, right).

### Environment

#### Portable Weather Station

A portable weather station was set up roadside for both days of paving operations (Figure C.2). The manufacturer is Davis Instruments and the model is Vantage Pro2™ 6152C.

The weather station includes the following sensors:

- Rain collector;
- Temperature;
- Humidity;
- Pressure; and
- Anemometer (wind speed).

The weather station automatically logs data at 1-min intervals. Data logs are downloaded to a laptop computer. The download log includes the date and time, temperature, humidity, dew point, wind speed, wind direction, and barometric pressure.

#### Pavement Surface Temperatures

Fresh and hardened pavement surface temperatures at locations just ahead of the paving operation were recorded throughout each day. The sensor used for these temperature measurements was a handheld, infrared laser device as shown in Figure C.3.

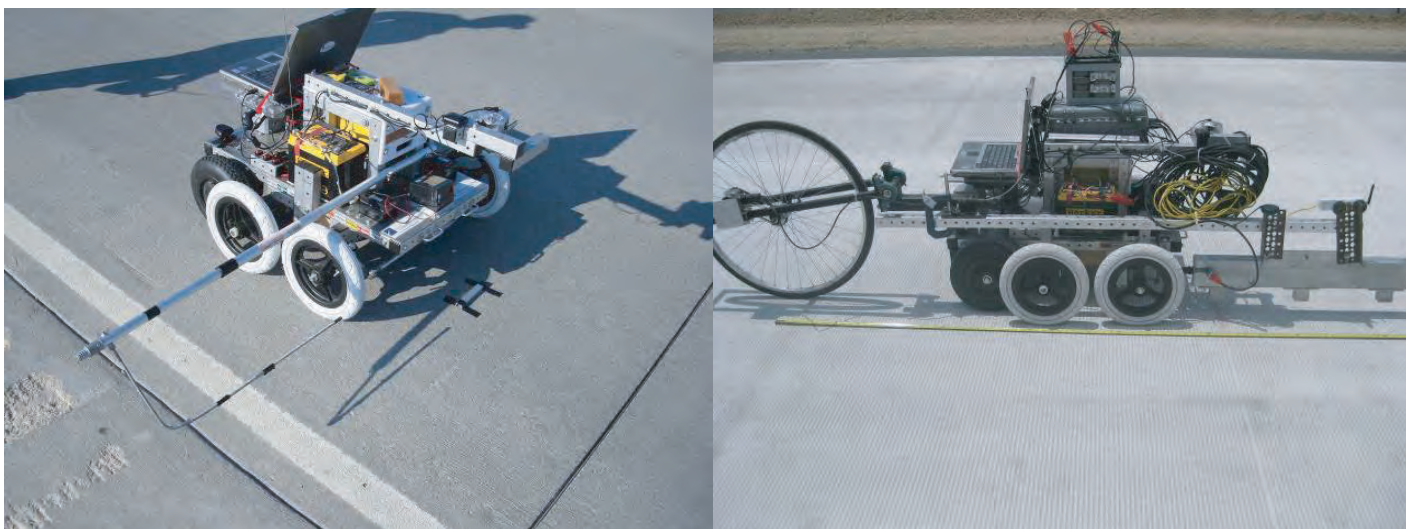
### Concrete Materials Data

The Georgia Department of Transportation (Georgia DOT) standard specifications require a slump value less than 2.5 in. and air content between 3% and 6.5%. The 24-h compressive strength is mix specific and determined in the field by the project engineer. The mixture design information is provided in Figure C.4.



**Table C.1. Summary of Sensor Information**

| Sensor                          | Manufacturer  | Model               | Description   |
|---------------------------------|---------------|---------------------|---|
| Draw wire                       | Micro-Epsilon | WDS-1000-P60-CR-HTL | Measures change in distance along a single axis by extension and retraction of a draw wire.                                 |
| Q-Flex accelerometer            | Honeywell     | QA650               | Measures static and dynamic linear acceleration along a single axis.  |
| Inertial measuring unit         | MicroStrain   | Inertia-Link        | Measures static and dynamic linear acceleration about three axes, and static and dynamic angular velocity about three axes. |
| Fifth wheel with rotary encoder | US Digital    | E6S-1000-625-H      | Measures change in angular position around an axis of rotation.   |



**Figure C.1. RoboTex measurement system in typical configuration (left) and with the Ames Engineering RTP mounted (right).**



**Figure C.2. Portable weather station.**



**Figure C.3. Noncontact infrared thermometer for pavement surface temperatures. The manufacturer is Neiko.**

| <b>Cementitious Materials</b> |  | Source                                 | Type | Spec. Gravity | lb/yd <sup>3</sup> | % Replacement by Mass       |
|-------------------------------|--|--|------|---------------|--------------------|-----------------------------|
| Portland Cement:              |  | Suwanee American Cement - Branford, FL | I    | 3.140         | 487                |                             |
| GGBFS:                        |  |  |      |               |                    |                             |
| Fly Ash:                      |  | Boral - Juliette, GA                   | C    | 2.670         | 68                 | 12.25%                      |
| Silica Fume:                  |  |  |      |               |                    |                             |
| Other Pozzolan:               |  |  |      |               |                    |                             |
|                               |  |  |      |               | <b>555</b>         | <b>lb/yd<sup>3</sup></b>    |
|                               |  |  |      |               | <b>5.9</b>         | <b>sacks/yd<sup>3</sup></b> |

| <b>Aggregate Information</b> |  | Source                          | Type    | Spec. Gravity SSD | Absorption (%) |
|------------------------------|--|---------------------------------|---------|-------------------|----------------|
| Coarse Aggregate:            |  | Aggregates USA Hitchcock Quarry | Granite | 2.700             | 0.60%          |
| Intermediate Aggregate:      |  |                                 |         |                   |                |
| Fine Aggregate #1:           |  | Scruggs Sand Co., - Adel, GA    | Natural | 2.650             | 0.27%          |
| Fine Aggregate #2:           |  |                                 |         |                   |                |

|   |        |
|---|--------|
| Coarse Aggregate %:                     | 51.0%  |
| Intermediate Aggregate %:               |        |
| Fine Aggregate #1 % of Total Fine Agg.: | 100.0% |
| Fine Aggregate #2 % of Total Fine Agg.: |        |
| Fine Aggregate #1 %:                    | 49.0%  |
| Fine Aggregate #2 %:                    |        |

| <b>Mix Proportion Calculations</b>  |       |
|-------------------------------------|-------|
| Water/Cementitious Materials Ratio: | 0.440 |
| Air Content:                        | 4.00% |

|                         | Volume (ft <sup>3</sup> )              | Batch Weights SSD (lb/yd <sup>3</sup> ) | Spec. Gravity | Absolute Volume (%) |
|-------------------------|--|---|---------------|---------------------|
| Portland Cement:        | 2.486                                  | 487                                     | 3.140         | 9.21%               |
| GGBFS:                  |  |   |               |                     |
| Fly Ash:                | 0.408                                  | 68                                      | 2.670         | 1.51%               |
| Silica Fume:            |  |   |               |                     |
| Other Pozzolan:         |  |   |               |                     |
| Coarse Aggregate:       | 9.748                                  | 1,650                                   | 2.700         | 36.10%              |
| Intermediate Aggregate: |  |   |               |                     |
| Fine Aggregate #1:      | 9.365                                  | 1,550                                   | 2.650         | 34.69%              |
| Fine Aggregate #2:      |  |   |               |                     |
| Water:                  | 3.913                                  | 244                                     | 1.000         | 14.49%              |
| Air:                    | 1.080                                  |   |               | 4.00%               |
|                         | <b>27.000</b>                          | <b>3,999</b>                            |               | <b>100.00%</b>      |
|                         | <b>Unit Weight (lb/ft<sup>3</sup>)</b> | <b>148.1</b>                            |               |                     |

| <b>Admixture Information</b> |  | Source/Description                          |
|------------------------------|--|---|
| Air Entraining Admix.:       |  | Hunt Process Corp.-Southern AIR-IN-XT       |
| Admix. #1:                   |  | Hunt Process Corp.-South HPS-R2 Type A or D |

Figure C.4. Mixture design information.

**GA I-75 Real Time Smoothness Field Evaluation  
Fresh Concrete Testing Summary (All Testing Performed by GDOT)**

| Date   | Time  | Conc. Temp.<br>(°F) | Slump<br>(in.) | Air Content<br>(%) | Avg. Compressive<br>Strength (24 hr)<br>(psi) |
|--|-------|---------------------|----------------|--------------------|---|
| 5/10/2010  | 13:45 | 81.2                | 2.0            | 5.5                | 2,270   |
| 5/10/2010  | 15:30 | 82.5                | 2.0            | 5.3                | 2,320   |
| 5/11/2010  | 11:45 | 81.7                | 2.0            | 5.0                | 2,380   |
| 5/11/2010  | 13:40 | 82.9                | 1.8            | 5.4                | NA  |
| Average of all data recorded<br>by SHRP 2 R06 team |       | 82.1                | 1.9            | 5.3                | 2,320   |

Note: NA = not available.

**Figure C.5. Summary of concrete test results. Conc. = concrete.**

Additional information collected during the field evaluation includes concrete temperature, slump, air content, average compressive strength, and gradation. Figure C.5 through Figure C.8 provide a summary of the quality assurance test data provided by the Georgia DOT for informational purposes and as a means of characterizing the concrete materials that were used during the field evaluation.

## Early-Age Temperature Profiles of Continuously Reinforced Concrete Pavement on Asphalt Base

One of the factors considered by the research team when looking for a project to evaluate the real-time smoothness measuring technologies was the influence that slab curling

| Project: NH-75-1(205). Cook County, Georgia    |        |                        |                    |         |                        |   |                       |
|--|--------|------------------------|--------------------|---------|------------------------|---|-----------------------|
| Mix ID: Mainline                               |        |                        |                    |         |                        |   |                       |
| Sample Comments: Testing performed by GDOT OMR |        |                        |                    |         |                        |   |                       |
| Test Date: 11-May-10                           |        |                        |                    |         |                        |   |                       |
| Total Cementitious Material:                   |        | 555 lb/yd <sup>3</sup> |                    |         |                        |   |                       |
| Agg. Ratios:                                   |        | 51.00%                 | 49.00%             | 100.00% |                        |   |                       |
| Sieve  | Coarse | Intermediate<br>#1     | Intermediate<br>#2 | Fine #1 | Combined %<br>Retained | Combined %<br>Retained On<br>Each Sieve | Combined %<br>Passing |
| 2 ½"   | 100%   | na                     | na                 | 100%    | 0%                     | 0%                                      | 100%                  |
| 2"   | 100%   | na                     | na                 | 100%    | 0%                     | 0%                                      | 100%                  |
| 1 ½"   | 100%   | na                     | na                 | 100%    | 0%                     | 0%                                      | 100%                  |
| 1"   | 98%    | na                     | na                 | 100%    | 1%                     | 1%                                      | 99%                   |
| ¾"   | 82%    | na                     | na                 | 100%    | 9%                     | 8%                                      | 91%                   |
| ½"   | 34%    | na                     | na                 | 100%    | 34%                    | 24%                                     | 66%                   |
| ⅜"   | 18%    | na                     | na                 | 100%    | 42%                    | 8%                                      | 58%                   |
| #4   | 5%     | na                     | na                 | 100%    | 48%                    | 7%                                      | 52%                   |
| #8   | 3%     | na                     | na                 | 97%     | 51%                    | 2%                                      | 49%                   |
| #16  | 2%     | na                     | na                 | 84%     | 58%                    | 7%                                      | 42%                   |
| #30  | 1%     | na                     | na                 | 56%     | 72%                    | 14%                                     | 28%                   |
| #50  | 1%     | na                     | na                 | 20%     | 90%                    | 18%                                     | 10%                   |
| #100   | 1%     | na                     | na                 | 5%      | 97%                    | 7%                                      | 3%                    |
| #200   | 1.0%   | na                     | na                 | 0.5%    | 99.2%                  | 2.2%                                    | 0.8%                  |

Note: na = not applicable.

**Figure C.6. Sieve analysis test data provided by Georgia DOT Office of Materials and Research.**



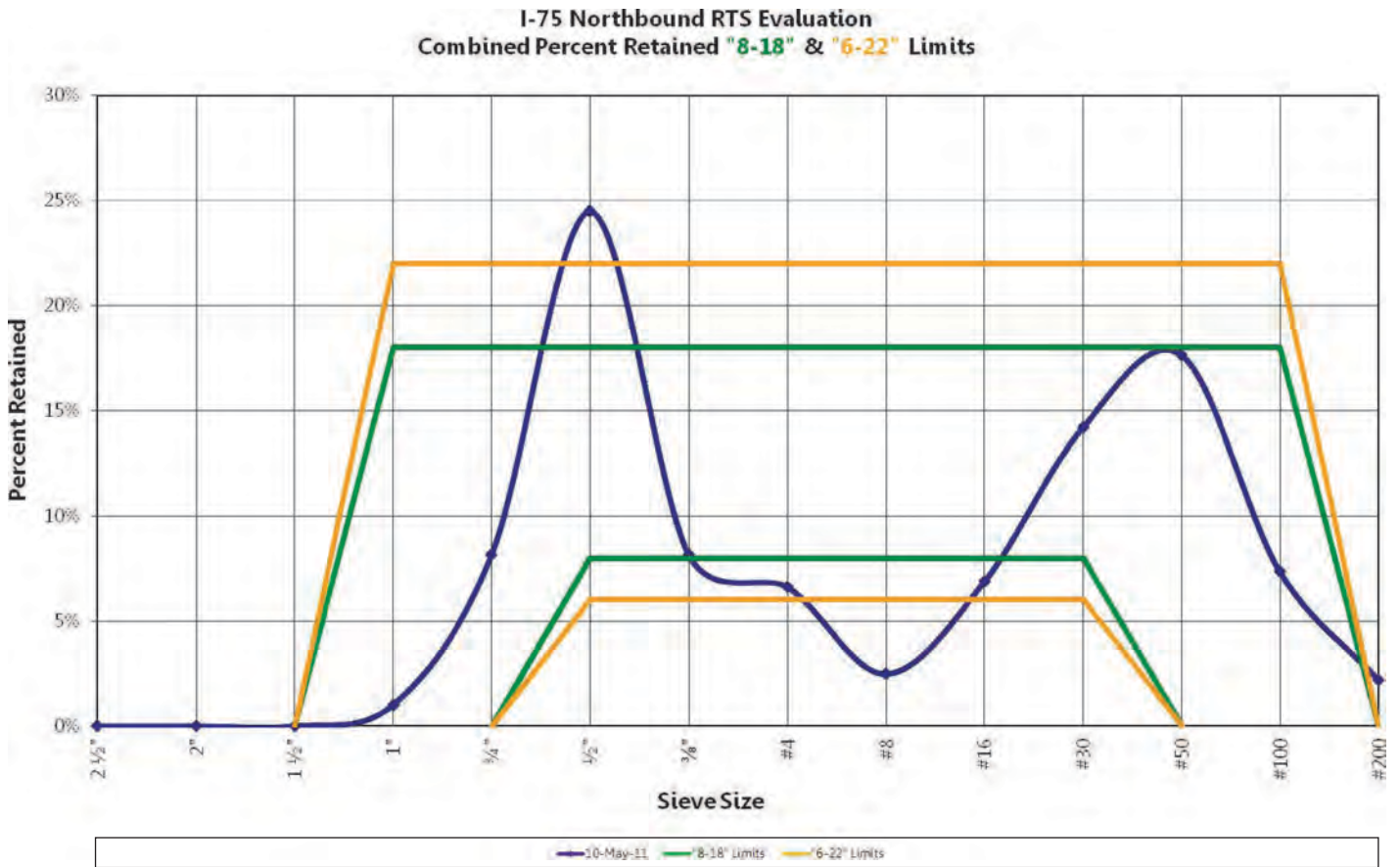


Figure C.7. Gradation as combined percent retained on individual sieves.

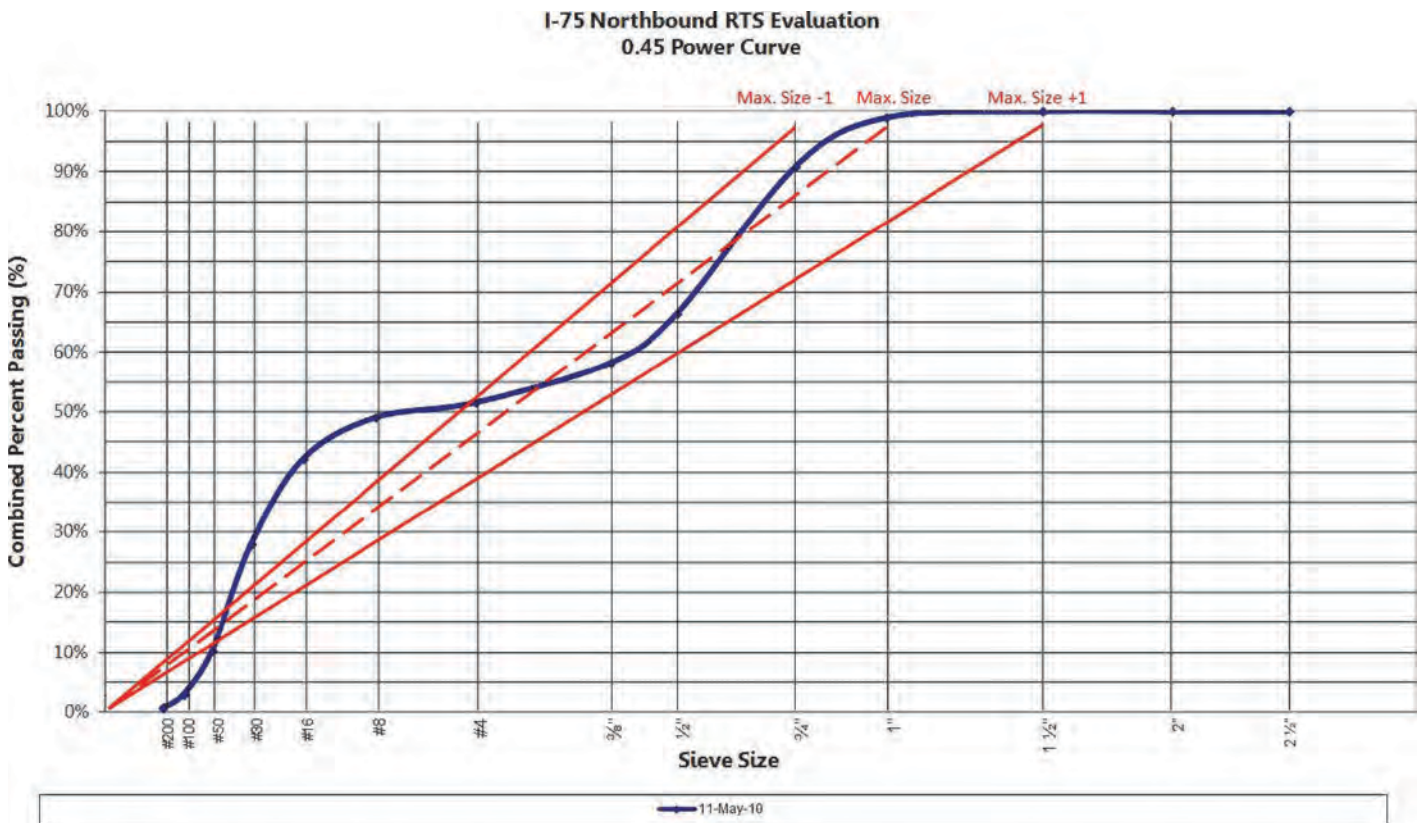
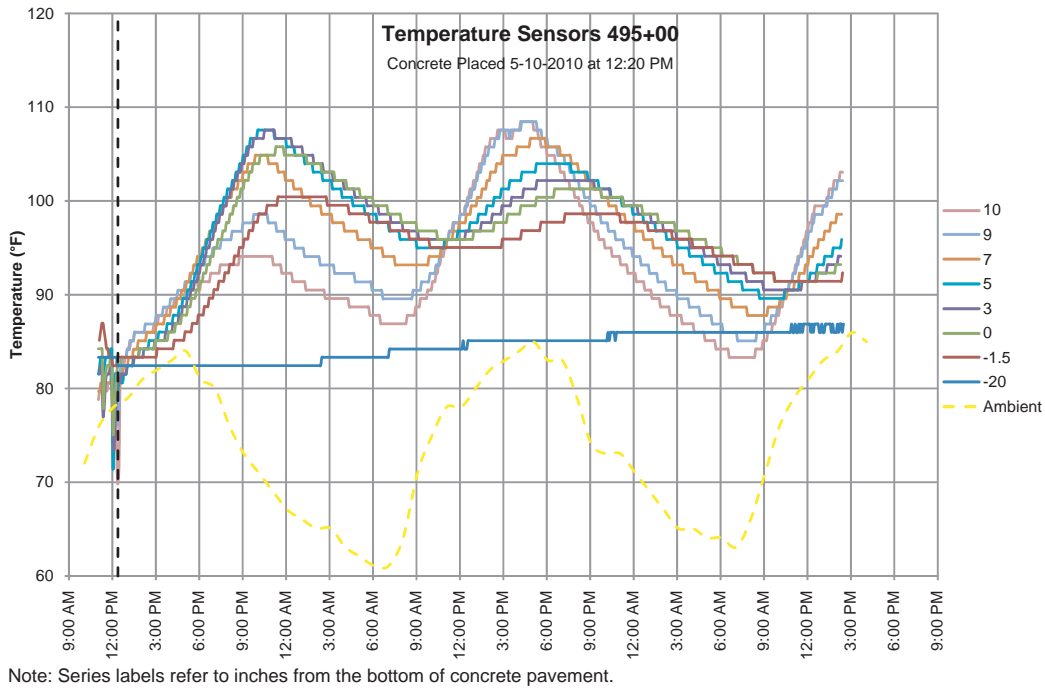


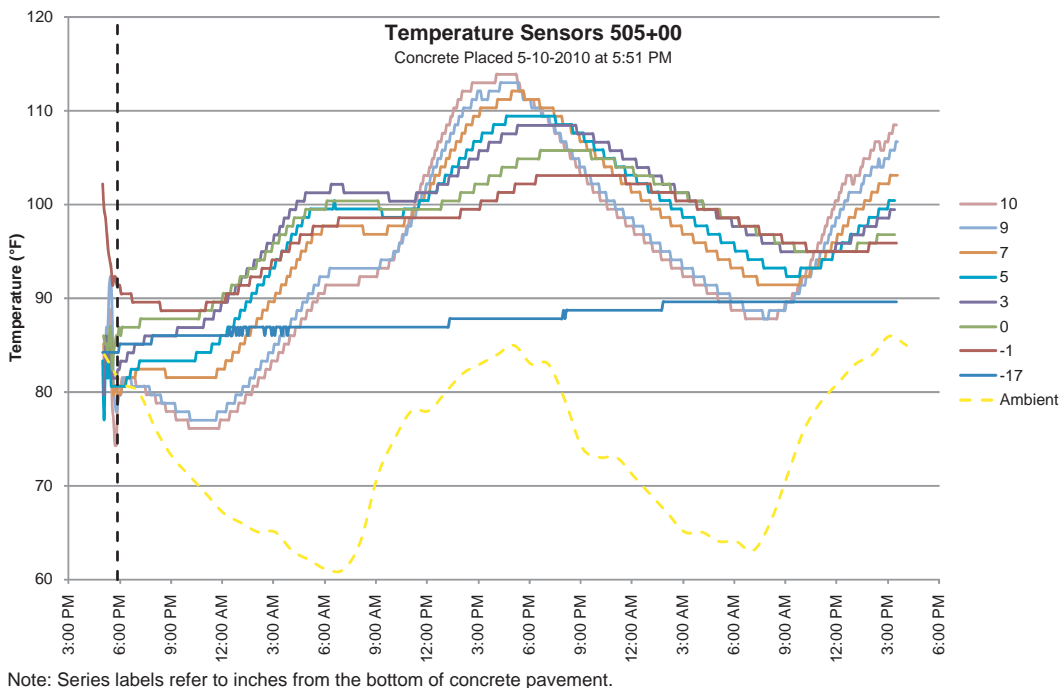
Figure C.8. Gradation on a 0.45 power curve.



**Figure C.9. Early-age temperature profile of CRCP at Station 495+00.**

may have on profile measurements. The I-75 project in Georgia was chosen for the Phase 2 study partly because it is a continuously reinforced concrete pavement (CRCP), which will exhibit less curling than a jointed pavement. Temperature sensors and data loggers were installed at two different locations as part of the field-testing protocol. The early-age temperature profile of the pavement is shown in Figures C.9 and C.10. The plots demonstrate temperature trends that are

typical for concrete paving, with a combined influence of the heat of hydration along with environmental influences. The different trends in these plots show temperatures at various depths, including two sensors installed below the bottom of the concrete. In general, the magnitude of the temperature changes is less as the sensor is further from the surface. The spread in temperatures from top to bottom are what is used to gauge the degree of temperature curling.



**Figure C.10. Early-age temperature profile of CRCP at Station 505+00.**

## APPENDIX D

# Phase 3—Arkansas Field Demonstration Data Reduction and Analysis

Appendix D contains data from the Arkansas field demonstration. The figure plots, which are ProVAL screenshots, show profile elevations, profilograph simulations, ride quality analyses, and power spectral density analyses. Tables contain the cross-correlation data from ProVAL.

Figures D.1 and D.2 plot elevation versus distance for the left lane. The Ames-Hardened profile was taken using a lightweight profiler for quality control. All three GSI-Bridge-Hardened passes, shown in both Figure D.1 and Figure D.2, were measured after the concrete had hardened overnight, whereas GSI-Bridge-Wet was measured in real time. As seen in Figure D.1 and the cross-correlation tables later in this appendix, the paver-mounted profiler has the trend least similar to the others.

Figure D.3 shows localized roughness of the left lane based on a profilograph simulation with a 0-in. blanking band.

Figure D.4 plots the international roughness index (IRI) for each profile measured with the various profilers. The settings were for continuous IRI with 50-ft segments. The paver-mounted profiler shows a consistently higher IRI compared with the other profilers.

In the power spectral density (PSD) analysis in Figure D.5, a wave length of interest can be seen around 14.7 ft. In addition, GSI-Paver-Wet has peaks between approximately 3.5 and 5.6 ft.

Figure D.6 shows the power spectral density for left lane profiles as well, but with the log scale.

Values in Table D.1 are the correlation percentages between various profiler runs, with an IRI filter applied. A higher percentage means better correlation. Maximum correlation was between GSI-Bridge-Hardened-Pass2-L—Filtered and GSI-

Bridge-Hardened-Pass3-L—Filtered. Least correlation was between Ames-Hardened-Pass1-L and GSI-Paver-Wet-1000-L—Filtered.

Values in Table D.2 show how many feet the comparison profile was shifted to best align with the basis profile.

Figure D.7 plots elevation versus distance similar to Figure D.1, but for the right lane instead of the left lane.

Elevations for the three hardened passes measured with the stand-alone GSI machine are plotted in Figure D.8.

Figure D.9 shows localized roughness of the right lane based on a profilograph simulation with a 0-in. blanking band.

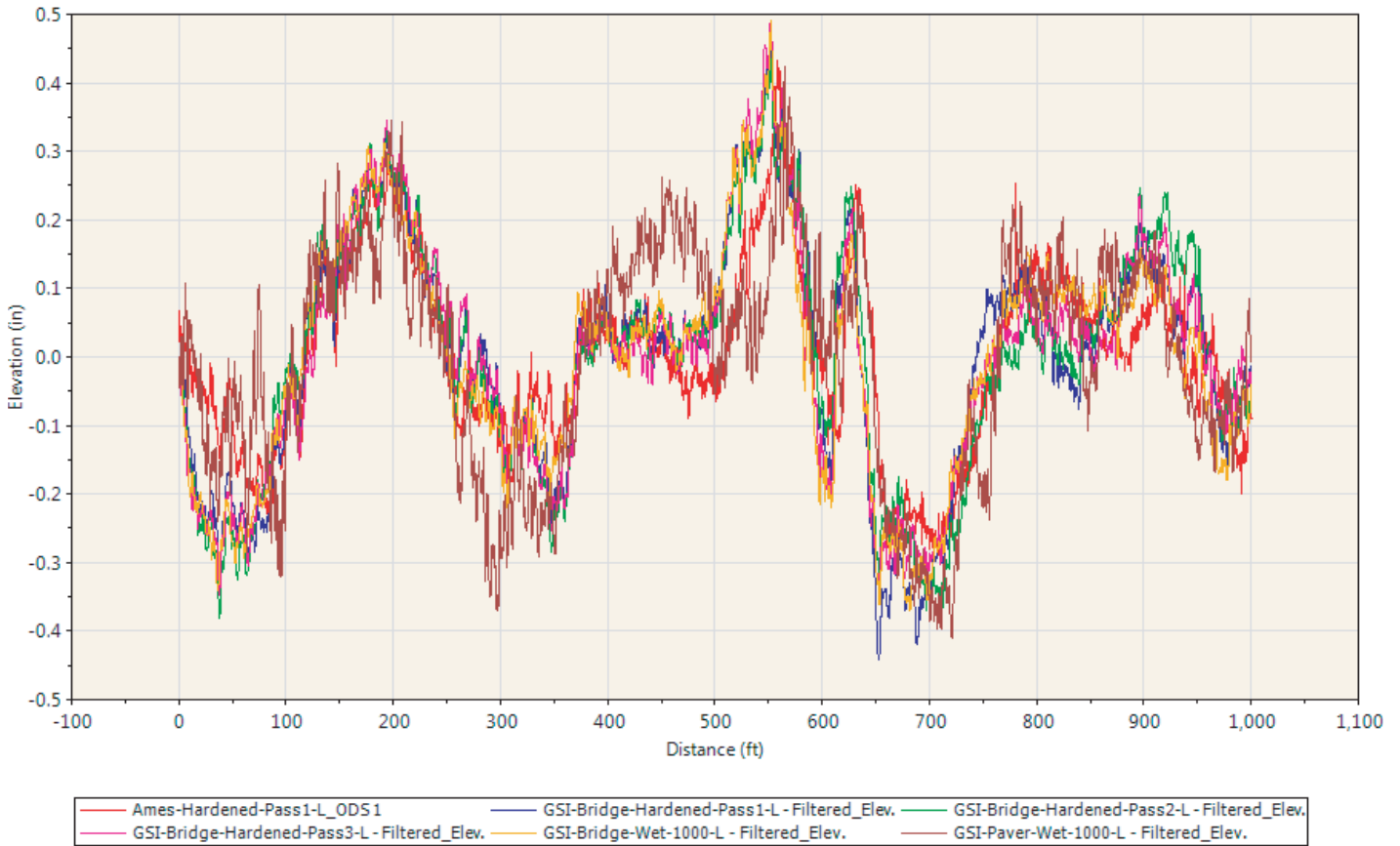
Figure D.10 plots the IRI for each profile measured with the various profilers. The settings were for continuous IRI with 50-ft segments. The paver-mounted profiler shows a consistently higher IRI compared with the other profilers.

In the power spectral density analysis in Figure D.11, wavelengths of interest can be seen around 14.8 ft and 39.3 ft. In addition, GSI-Paver-Wet has peaks between approximately 3.1 and 8.8 ft.

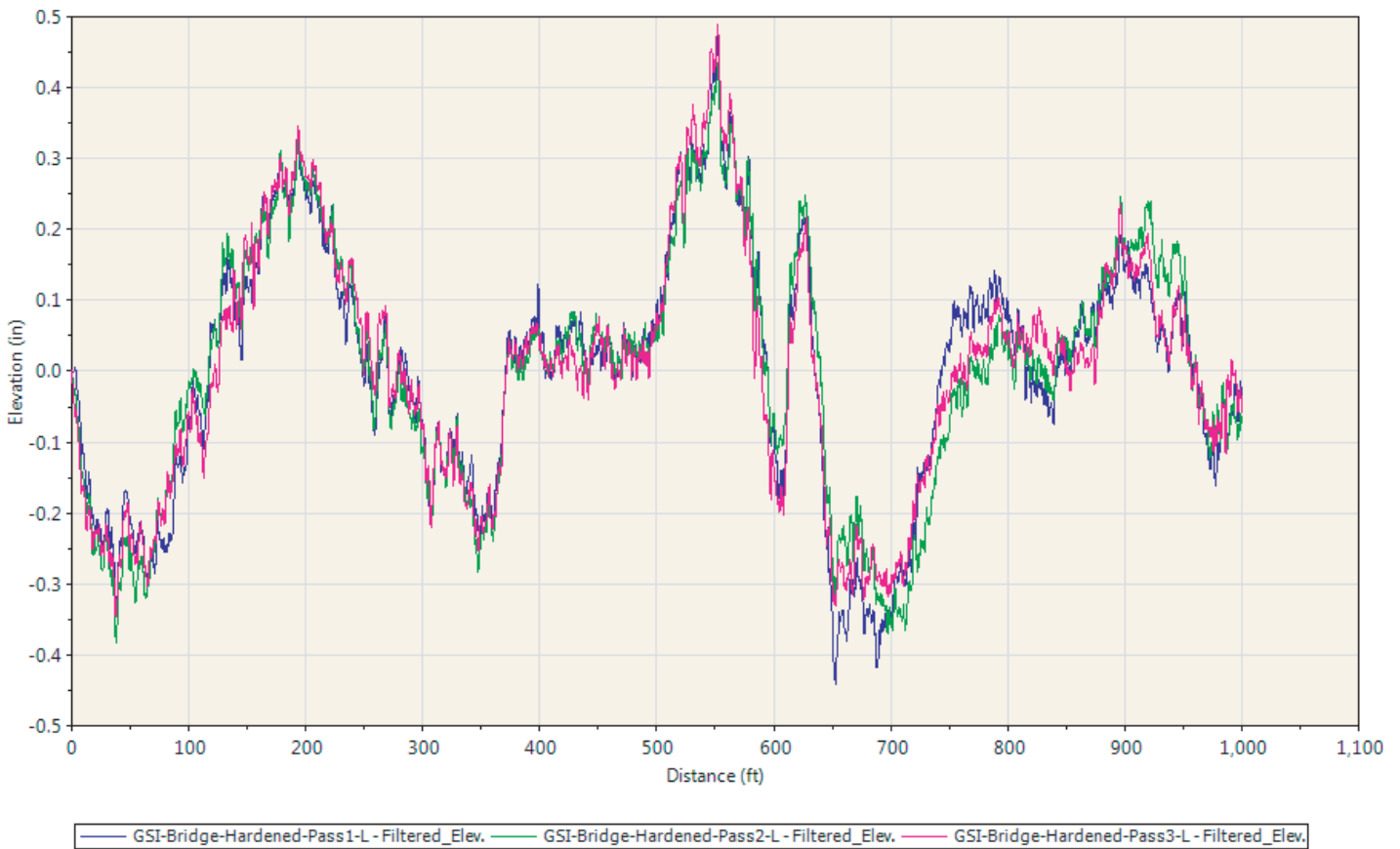
Figure D.12 shows the power spectral density for right lane profiles as well, but with the log scale.

Values in Table D.3 are the correlation percentages between various profiler runs, with an IRI filter applied. A higher percentage means better correlation. Maximum correlation was between GSI-Bridge-Hardened-Pass1-R—Filtered and GSI-Bridge-Hardened-Pass2-R—Filtered. Least correlation was between GSI-Bridge-Hardened-Pass2-R—Filtered and GSI-Paver-Wet-1000-R—Filtered.

Values in Table D.4 show how many feet the comparison profile was shifted to best align with the basis profile.

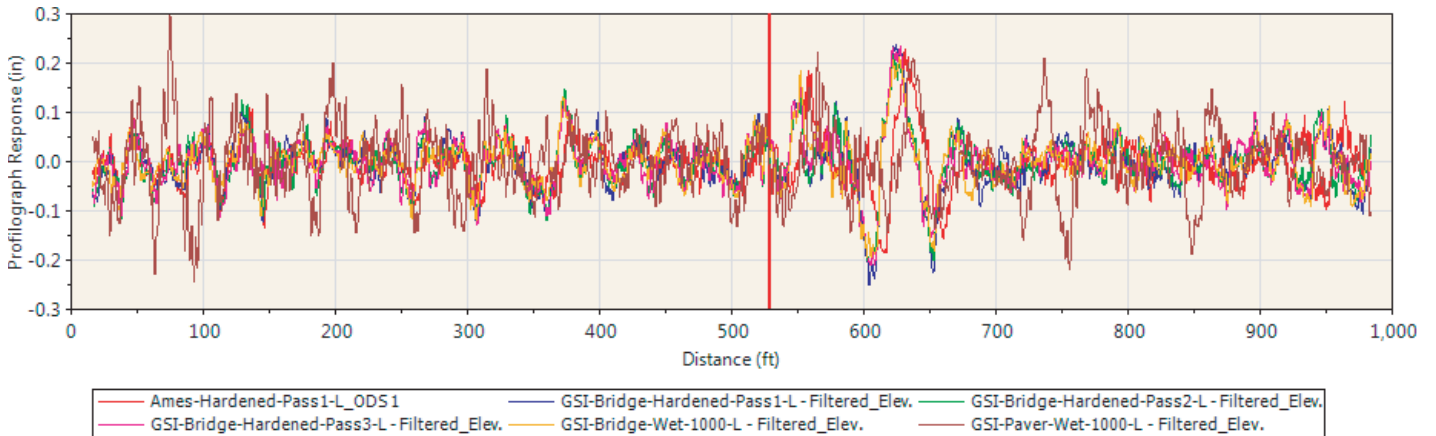


**Figure D.1.** All profile elevations (real time = wet and hardened concrete), left lane.

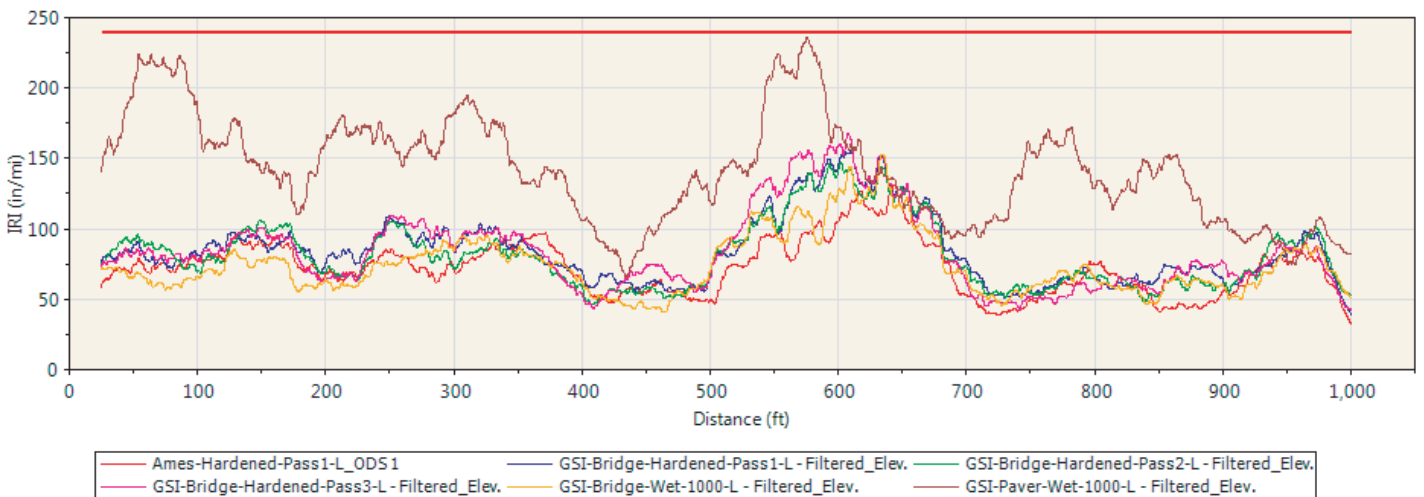


**Figure D.2.** Hardened concrete profile elevations, left lane, repeat runs with GSI machine/bridge.





**Figure D.3. Profilograph simulation of left lane using a 0-in. blanking band.**



**Figure D.4. IRI of left lane (real time = wet and hardened concrete).**

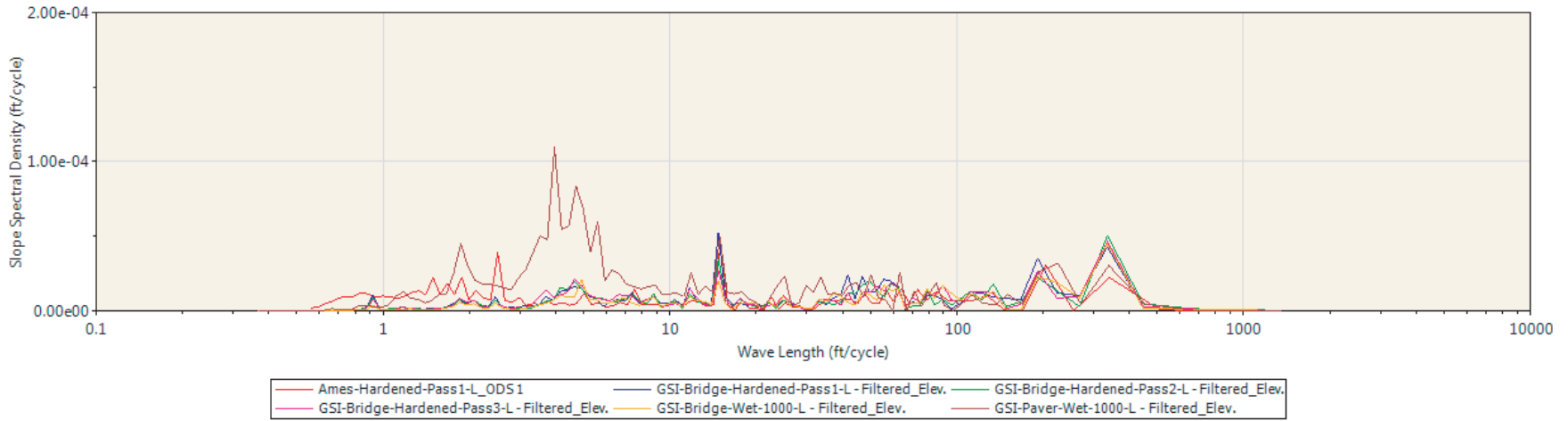


Figure D.5. Left lane PSD.

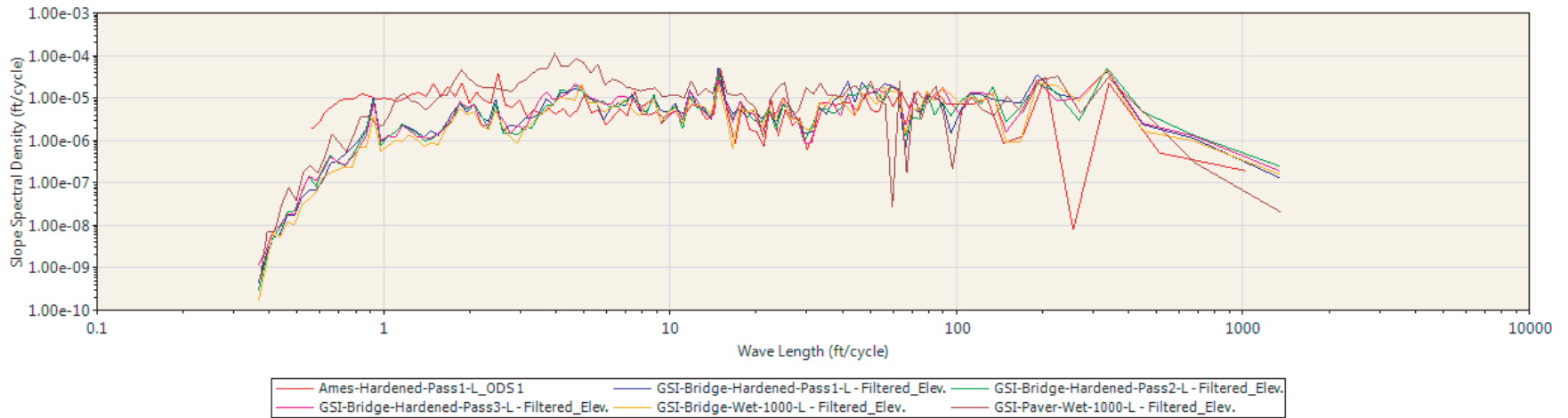


Figure D.6. Left lane PSD, log scale.

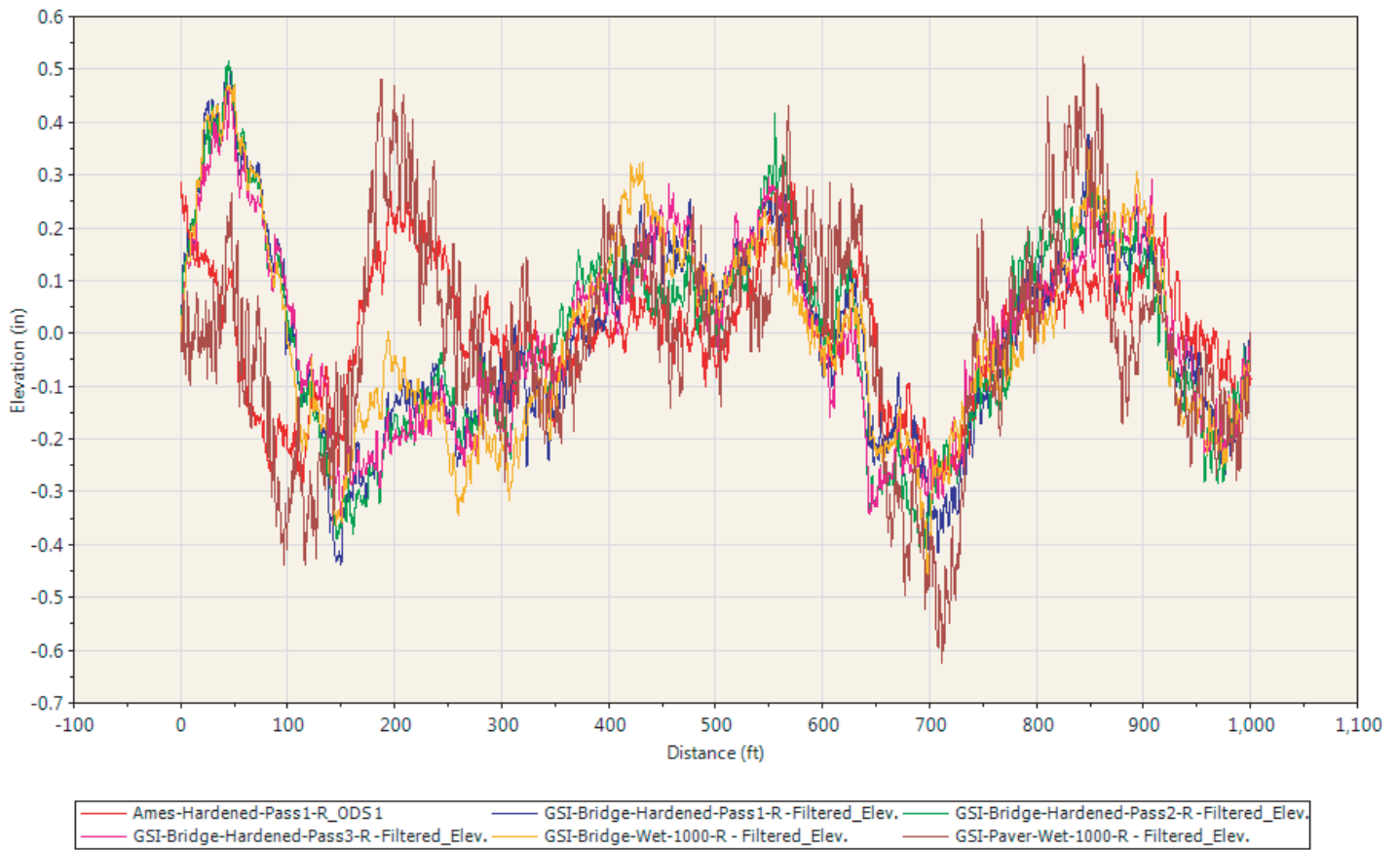
**Table D.1. Left Lane Cross Correlation: Correlation Percentage (Column Used as Basis)**

|                                      | <b>Ames-Hardened-Pass1-L</b> | <b>GSI-Bridge-Hardened-Pass1-L—Filtered</b> | <b>GSI-Bridge-Hardened-Pass2-L—Filtered</b> | <b>GSI-Bridge-Hardened-Pass3-L—Filtered</b> | <b>GSI-Bridge-Wet-1000-L—Filtered</b> |
|--------------------------------------|------------------------------|---|---|---|---------------------------------------|
| GSI-Bridge-Hardened-Pass1-L—Filtered | 23.5                         | na  |   |   |                                       |
| GSI-Bridge-Hardened-Pass2-L—Filtered | 21.9                         | 83.4  | na  |   |                                       |
| GSI-Bridge-Hardened-Pass3-L—Filtered | 19.9                         | 82.6  | 83.6  | na  |                                       |
| GSI-Bridge-Wet-1000-L—Filtered       | 21.7                         | 56.5  | 60.6  | 57.6  | na                                    |
| GSI-Paver-Wet-1000-L—Filtered        | 4.0                          | 7.5   | 4.9   | 5.6   | 6.0                                   |

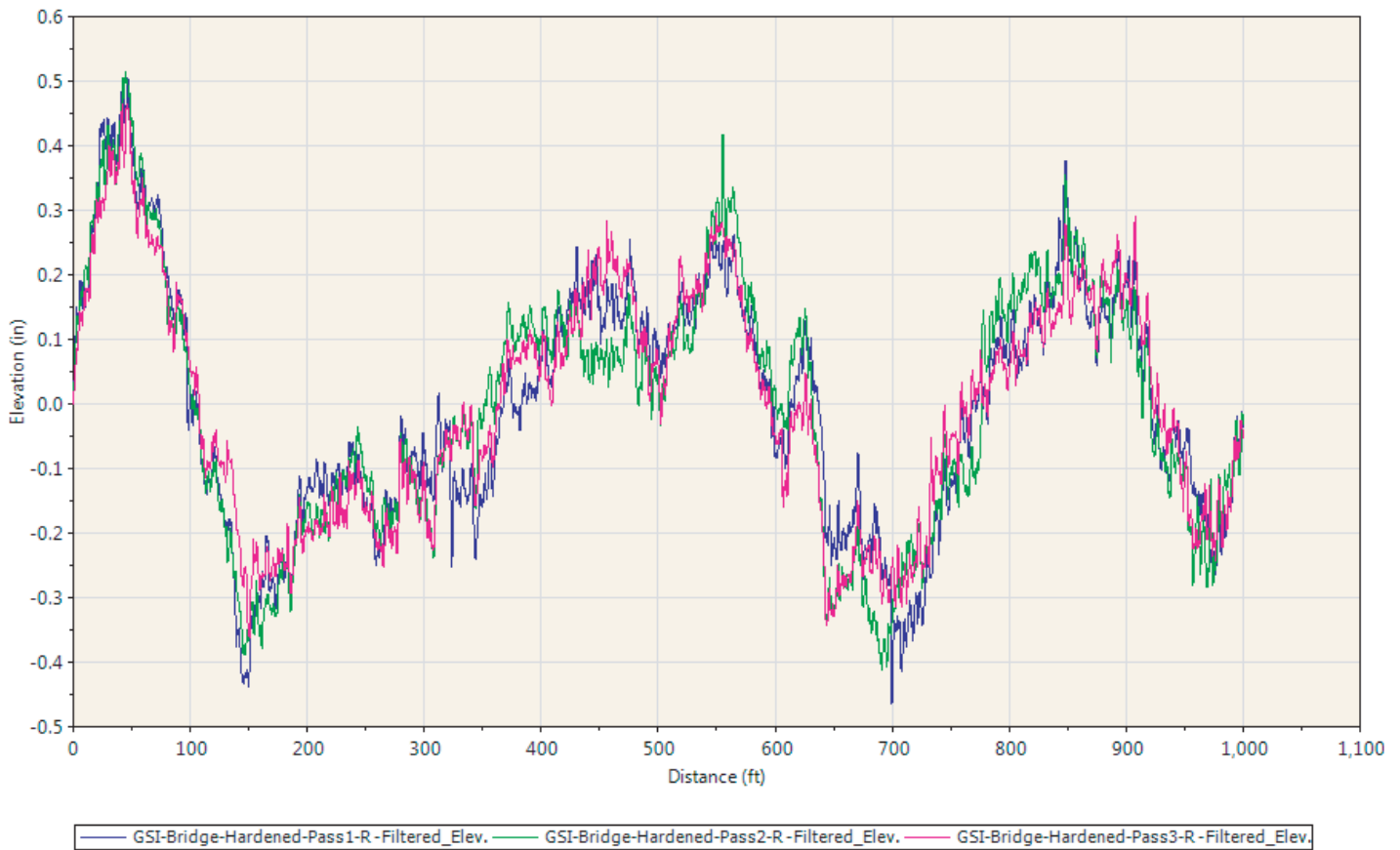
**Table D.2. Left Lane Cross Correlation: Relative Offsets<sup>a</sup>**

|                                      | <b>Ames-Hardened-Pass1-L</b> | <b>GSI-Bridge-Hardened-Pass1-L—Filtered</b> | <b>GSI-Bridge-Hardened-Pass2-L—Filtered</b> | <b>GSI-Bridge-Hardened-Pass3-L—Filtered</b> | <b>GSI-Bridge-Wet-1000-L—Filtered</b> |
|--------------------------------------|------------------------------|---|---|---|---------------------------------------|
| GSI-Bridge-Hardened-Pass1-L—Filtered | 1.75                         | na  |   |   |                                       |
| GSI-Bridge-Hardened-Pass2-L—Filtered | 1.50                         | -0.02                                       | na  |   |                                       |
| GSI-Bridge-Hardened-Pass3-L—Filtered | 2.00                         | 0.15  | 0.15  | na  |                                       |
| GSI-Bridge-Wet-1000-L—Filtered       | 2.50                         | 0.31  | 0.32  | -0.01                                       | na                                    |
| GSI-Paver-Wet-1000-L—Filtered        | -3.00                        | -0.67                                       | 0.32  | -7.21                                       | -6.89                                 |

<sup>a</sup>Relative offsets are in feet.

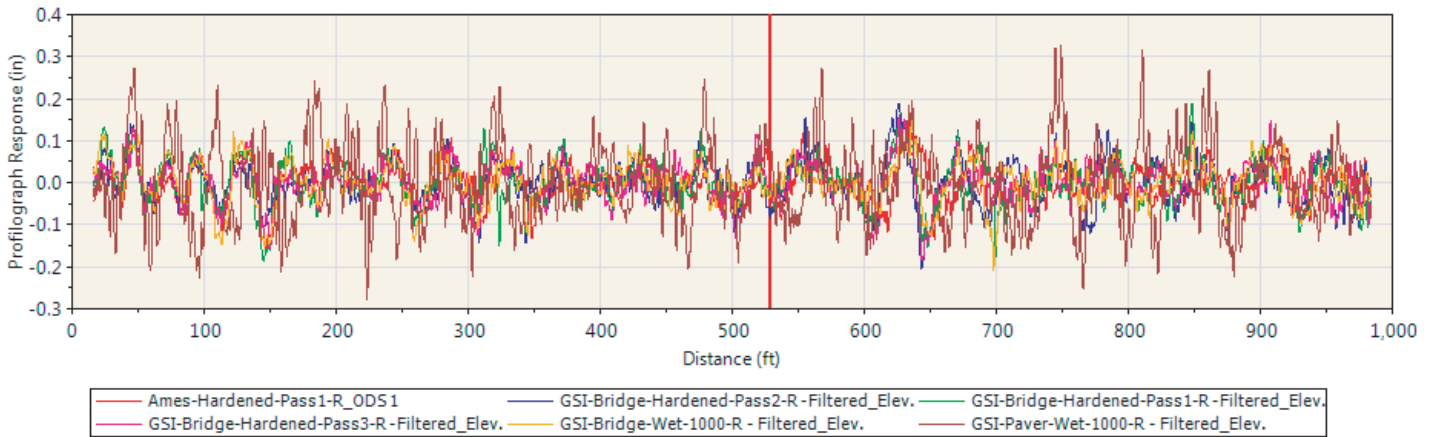


**Figure D.7.** All profile elevations (real time = wet and hardened concrete), right lane.

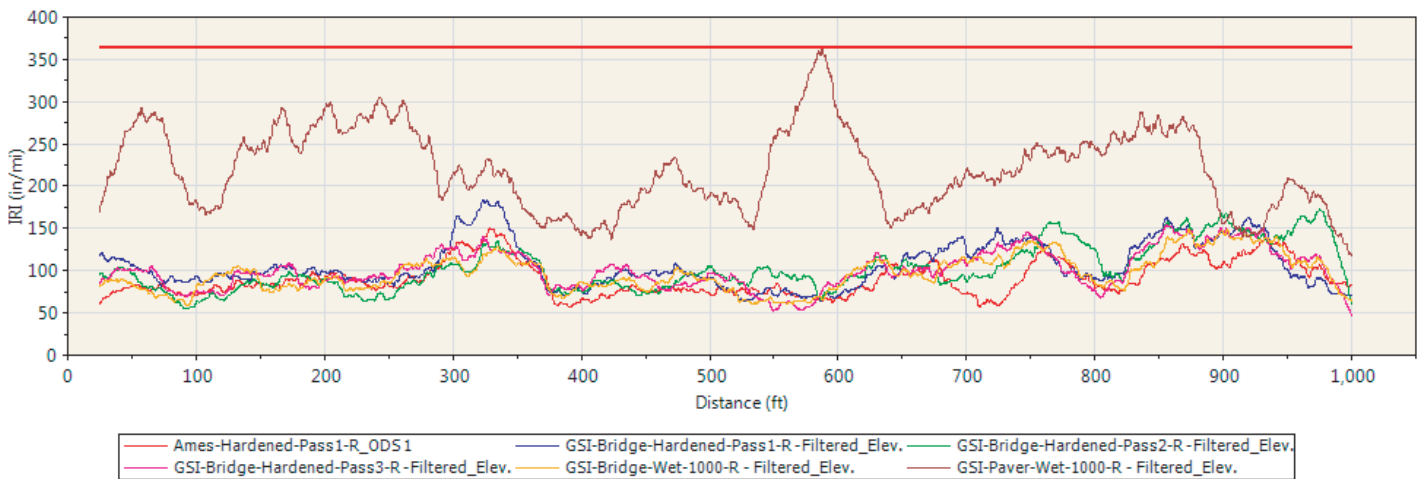


**Figure D.8.** Hardened concrete profile elevations, right lane, repeat runs with GSI machine/bridge.





**Figure D.9. Profilograph simulation of right lane using a 0-in. blanking band.**



**Figure D.10. IRI of right lane (real time = wet and hardened concrete).**

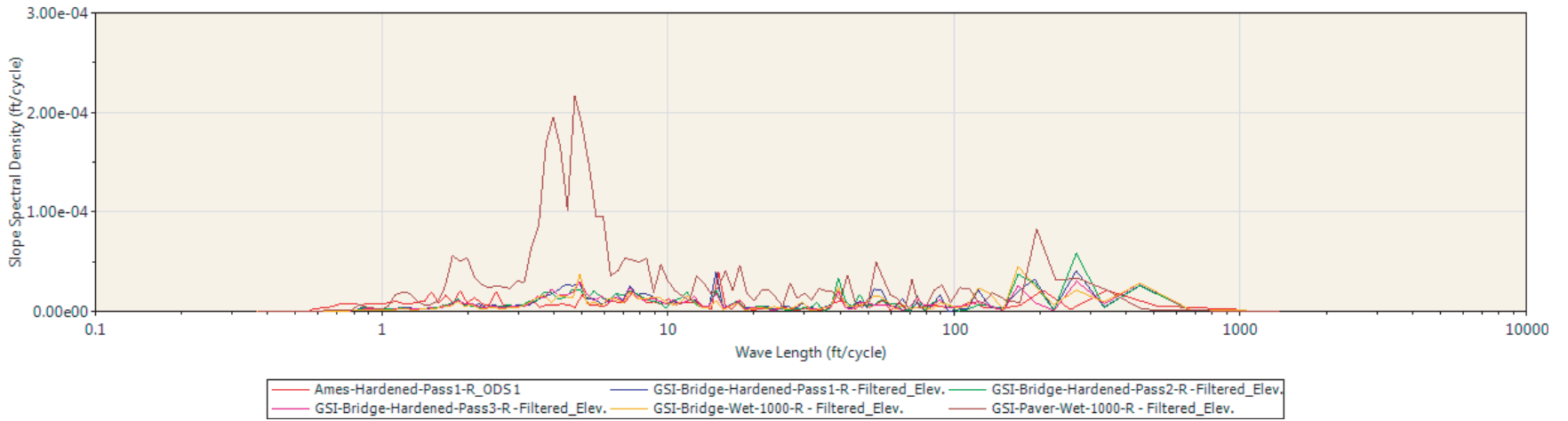


Figure D.11. Right lane PSD.

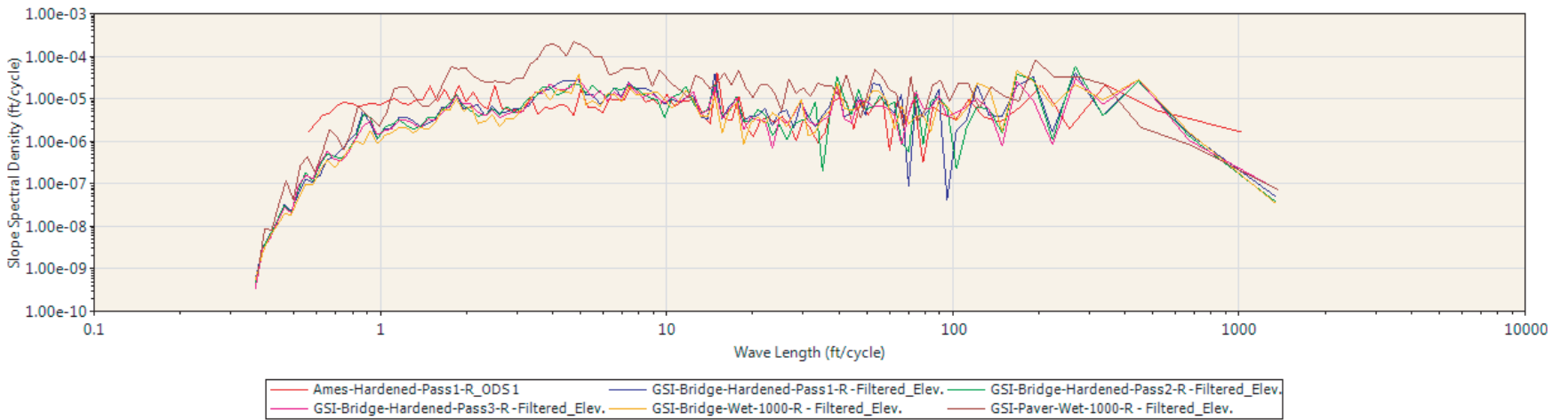


Figure D.12. Right lane PSD, log scale.

**Table D.3. Right Lane Cross-Correlation: Correlation Percentage (Column Used as Basis)**

|                                      | <b>Ames-Hardened-Pass1-R</b> | <b>GSI-Bridge-Hardened-Pass1-R—Filtered</b> | <b>GSI-Bridge-Hardened-Pass2-R—Filtered</b> | <b>GSI-Bridge-Hardened-Pass3-R—Filtered</b> | <b>GSI-Bridge-Wet-1000-R—Filtered</b> |
|--------------------------------------|------------------------------|---|---|---|---------------------------------------|
| GSI-Bridge-Hardened-Pass1-R—Filtered | 20.4                         | na  |   |   |                                       |
| GSI-Bridge-Hardened-Pass2-R—Filtered | 17.4                         | 68.1  | na  |   |                                       |
| GSI-Bridge-Hardened-Pass3-R—Filtered | 19.5                         | 67.1  | 65.9  | na  |                                       |
| GSI-Bridge-Wet-1000-R—Filtered       | 20.7                         | 63.8  | 63.7  | 65.0  | na                                    |
| GSI-Paver-Wet-1000-R—Filtered        | 5.9                          | 4.7   | 2.4   | 3.4   | 3.3                                   |

**Table D.4. Right Lane Cross Correlation: Relative Offsets<sup>a</sup>**

|                                      | <b>Ames-Hardened-Pass1-R</b> | <b>GSI-Bridge-Hardened-Pass1-R—Filtered</b> | <b>GSI-Bridge-Hardened-Pass2-R—Filtered</b> | <b>GSI-Bridge-Hardened-Pass3-R—Filtered</b> | <b>GSI-Bridge-Wet-1000-R—Filtered</b> |
|--------------------------------------|------------------------------|---|---|---|---------------------------------------|
| GSI-Bridge-Hardened-Pass1-R—Filtered | 4.24                         | na  |   |   |                                       |
| GSI-Bridge-Hardened-Pass2-R—Filtered | 4.24                         | 0.13  | na  |   |                                       |
| GSI-Bridge-Hardened-Pass3-R—Filtered | 4.49                         | 0.13  | -0.02                                       | na  |                                       |
| GSI-Bridge-Wet-1000-R—Filtered       | 3.49                         | -0.52                                       | -0.68                                       | -0.84                                       | na                                    |
| GSI-Paver-Wet-1000-R—Filtered        | -5.75                        | -5.75                                       | -4.93                                       | 6.03  | 0.96                                  |

<sup>a</sup> Relative offsets are in feet.

## APPENDIX E

# Phase 3—Michigan Field Demonstration Data Reduction and Analysis

Appendix E contains data from the Michigan field demonstration. The figure plots, which are ProVAL screenshots, show profile elevations, profilograph simulations, ride quality analyses, and power spectral density analyses. Tables contain the cross-correlation data from ProVAL.

Figure E.1 plots elevation versus distance in the left wheelpath of the passing lane. Real-time data from the Ames Engineering Real Time Profiler (RTP) is in two parts, 1-RTP-Part1—BWHP and 1-RTP-Part2—BWHP. This is because the data were saved and collection restarted about a third of the way into the section. There are three quality assurance (QA) control runs and three runs from a SurPRO 2000 reference profiler. BWHP profiles were high-pass filtered at 100 ft.

Figure E.2 shows localized roughness of the left wheelpath of the passing lane based on a profilograph simulation with a 0-in. blanking band.

Figure E.3 plots the international roughness index (IRI) for each profile measured with the various profilers. The settings were for continuous IRI with 50-ft segments. QA profiles included a 250-mm filter. The RTP profiler shows a consistently higher IRI compared with the other profilers.

The power spectral density (PSD) analysis for the left wheelpath of the passing lane can be seen in Figure E.4.

Figure E.5 shows the power spectral density for the left wheelpath of the passing lane as well, but with the log scale.

Values in Table E.1 are the correlation percentages between various profiler runs, with an IRI filter applied. As previously noted, the data from the Ames Engineering RTP is in two parts, 1-RTP-Part1 and 1-RTP-Part2, since the data collection restarted about a third of the way into the section. The cross-correlation data in Table E.1 and in subsequent tables in this appendix present correlation percentages between the real-time profilers (GOMACO GSI or Ames Engineering RTP: 1-RTP-Part1 or 1-RTP-Part2), the QA control profiler, and the SurPRO 2000 reference profiler. No results are provided in cases where both the row and the column pertain to

the same device (e.g., 1-RTP-Part1 and 1-RTP-Part2, which is the same device covering different stretches of the test section).

In Table E.1, a higher percentage means better correlation. Maximum correlation was between 1-QA Control-1 and 1-SurPRO-1. 1-RTP-Part2 was negatively correlated to both 1-QA Control-1 and 1-SurPRO-1.

Values in Table E.2 show how many feet the comparison profile was shifted to best align with the basis profile.

Figure E.6 plots elevation versus distance in the right wheelpath of the passing lane. Real-time data from the Ames Engineering RTP is in two parts, 1-RTP-Part1—BWHP and 1-RTP-Part2—BWHP. This is because the data were saved and collection was restarted about a third of the way into the section. There are three QA control runs and two runs from a SurPRO reference profiler. BWHP profiles were high-pass filtered at 100 ft.

Figure E.7 shows localized roughness of the right wheelpath of the passing lane based on a profilograph simulation with a 0-in. blanking band.

Figure E.8 plots the IRI for each profile measured with the various profilers. The settings were for continuous IRI with 50-ft segments. QA profiles included a 250-mm filter. The RTP profiler shows a consistently higher IRI compared with the other profilers.

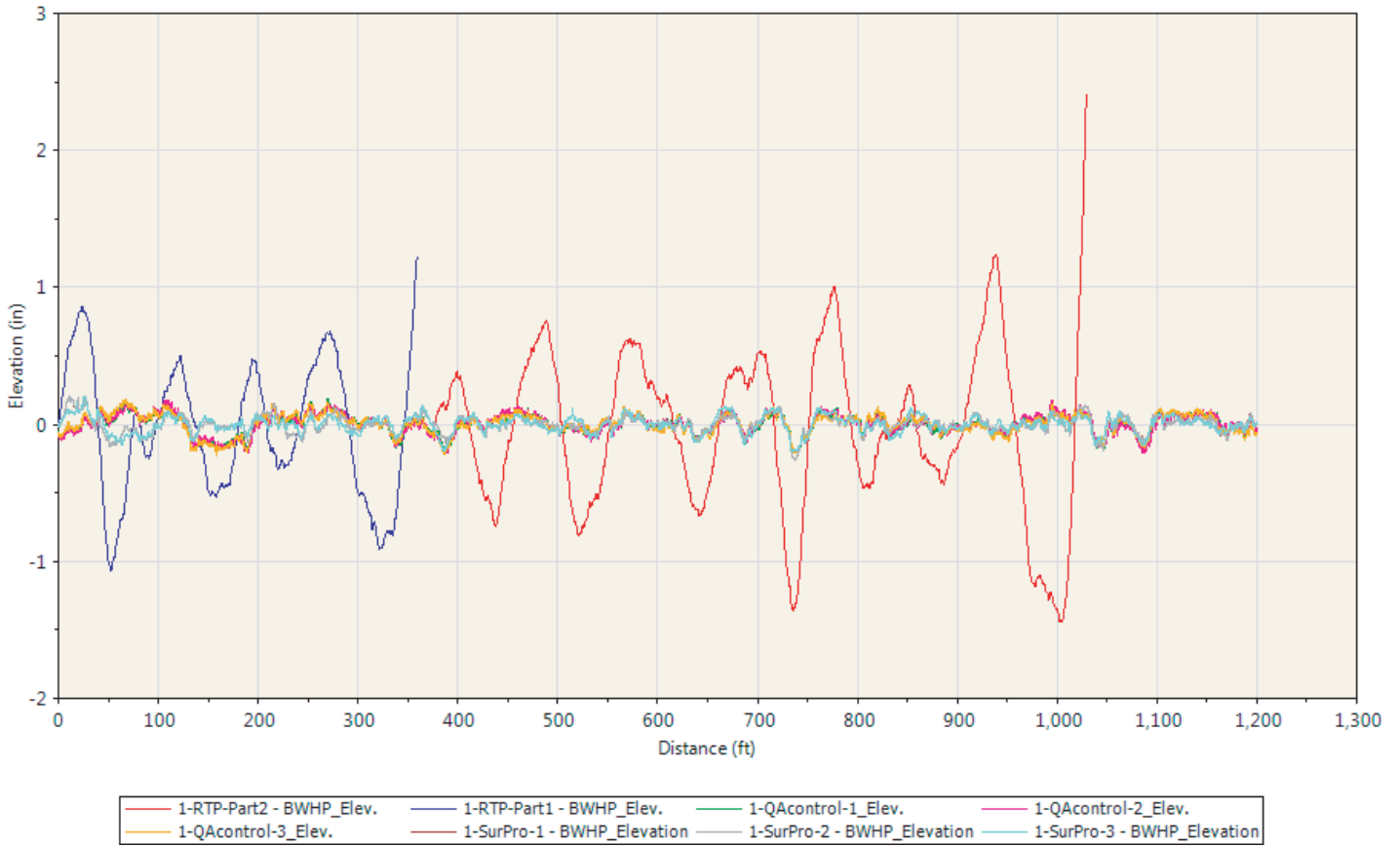
The power spectral density analysis for the right wheelpath of the passing lane can be seen in Figure E.9.

Figure E.10 shows the power spectral density for the right wheelpath of the passing lane as well, but with the log scale.

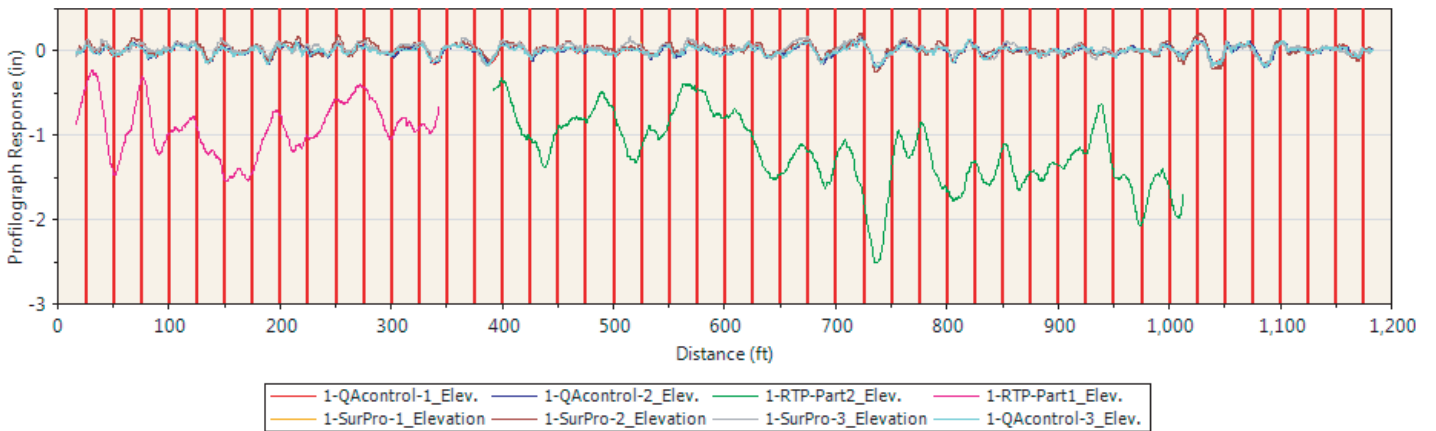
Values in Table E.3 are the correlation percentages between various profiler runs, with an IRI filter applied. A higher percentage means better correlation. Maximum correlation was between 2-QA Control-1 and 2-SurPRO-1. 2-RTP-Part2 was negatively correlated to both 2-QA Control-1 and 2-SurPRO-1.

Values in Table E.4 show how many feet the comparison profile was shifted to best align with the basis profile.

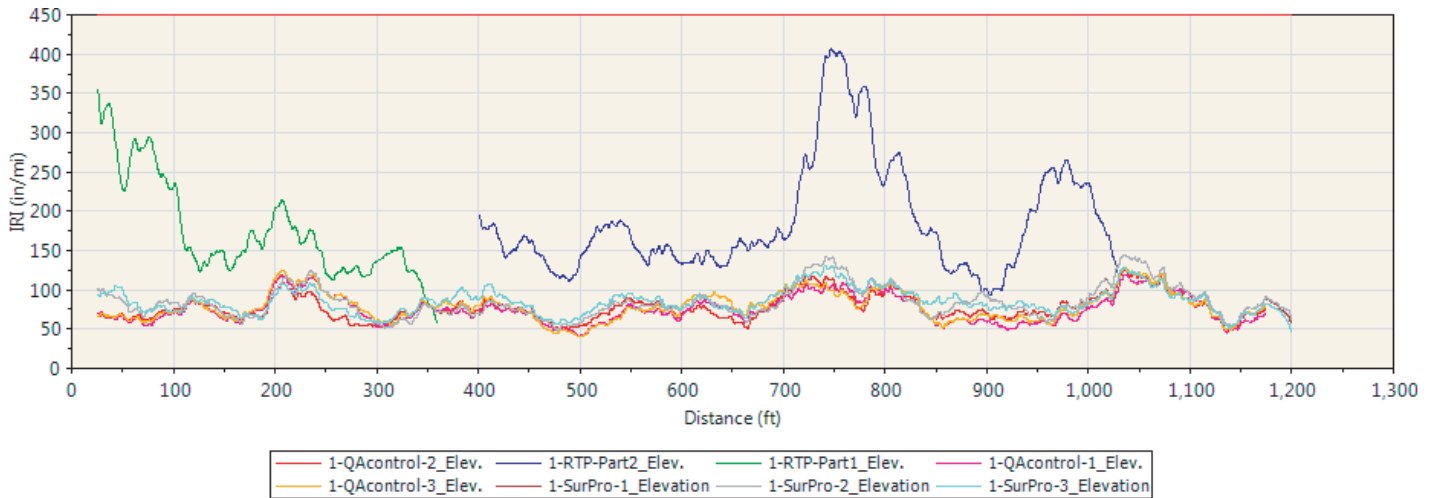




**Figure E.1. Profile elevations Path 1 (real time = RTP and hardened concrete).**



**Figure E.2. Profilograph simulation of Path 1 using a 0-in. blanking band.**



**Figure E.3. IRI of Path 1 (real time = RTP and hardened concrete).**

Figure E.11 plots elevation versus distance in the left wheelpath of the driving lane. The GOMACO GSI was mounted on a work bridge. There are also three QA control runs and one from a SurPRO 2000 reference profiler. BWHP profiles were high-pass filtered at 100 ft.

Figure E.12 shows localized roughness of the left wheelpath of the driving lane based on a profilograph simulation with a 0-in. blanking band.

Figure E.13 plots the IRI for each profile measured with the various profilers. The settings were for continuous IRI with 50-ft segments. QA profiles included a 250-mm filter. Values are similar, but the GSI profiler occasionally shows a higher IRI compared with the other profilers.

The power spectral density analysis for the left wheelpath of the driving lane can be seen in Figure E.14.

Figure E.15 shows the power spectral density for the left wheelpath of the driving lane as well, but with the log scale.

Values in Table E.5 are the correlation percentages between various profiler runs, with an IRI filter applied. A higher percentage means better correlation. Maximum correlation was between 3-QA Control-1 and 3-SurPRO-1.

Values in Table E.6 show how many feet the comparison profile was shifted to best align with the basis profile.

Figure E.16 plots elevation versus distance in the right wheelpath of the driving lane. The GOMACO GSI was mounted on a work bridge. There are also three QA control runs and four from a SurPRO reference profiler. BWHP profiles were high-pass filtered at 100 ft.

Figure E.17 shows localized roughness of the right wheelpath of the driving lane based on a profilograph simulation with a 0-in. blanking band.

Figure E.18 plots the IRI for each profile measured with the various profilers. The settings were for continuous IRI with 50-ft segments. QA profiles included a 250-mm filter. Values are similar, but the GSI profiler occasionally shows a higher IRI compared with the other profilers.

The power spectral density analysis for the right wheelpath of the driving lane can be seen in Figure E.19.

Figure E.20 shows the power spectral density for the right wheelpath of the driving lane as well, but with the log scale.

Values in Table E.7 are the correlation percentages between various profiler runs, with an IRI filter applied. A higher percentage means better correlation. Maximum correlation was between 4-QA Control-1 and 4-SurPRO-1.

Values in Table E.8 show how many feet the comparison profile was shifted to best align with the basis profile.

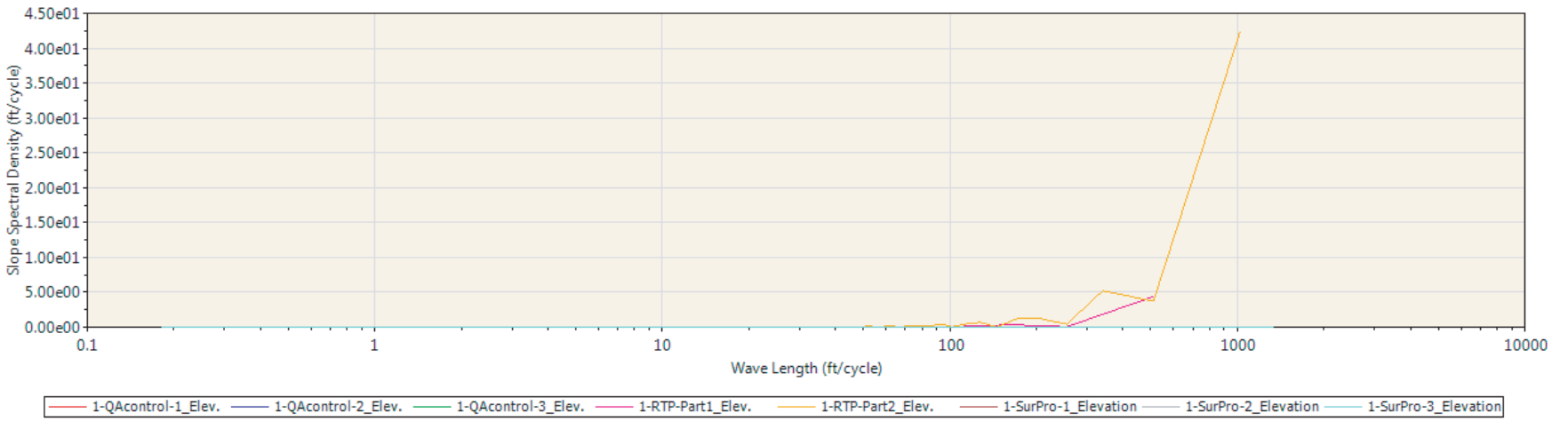


Figure E.4. Path 1 PSD.

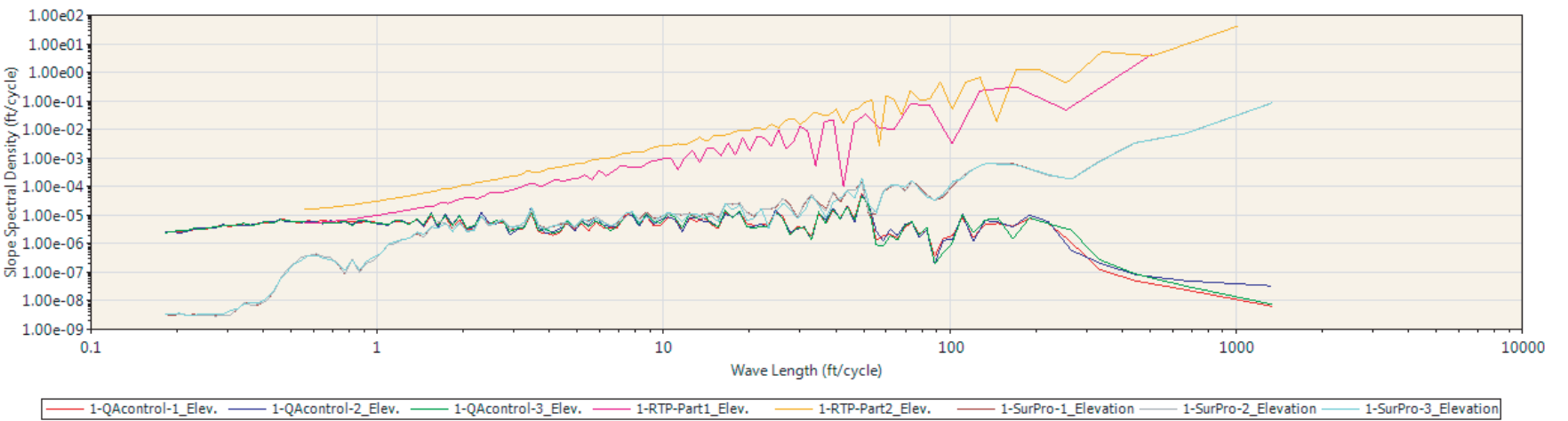


Figure E.5. Path 1 PSD, log scale.

**Table E.1. Path 1 Cross Correlation: Correlation Percentage (Column Used as Basis)**

|             | 1-QA Control-1 | 1-RTP-Part1 | 1-RTP-Part2 |
|-------------|----------------|-------------|-------------|
| 1-RTP-Part1 | 8.4            | na          | na          |
| 1-RTP-Part2 | -1.9           | na          | na          |
| 1-SurPRO-1  | 70.8           | 6.9         | -2.9        |

Note: na = not applicable.

**Table E.2. Path 1 Cross Correlation: Relative Offsets<sup>a</sup>**

|             | 1-QA Control-1 | 1-RTP-Part1 | 1-RTP-Part2 |
|-------------|----------------|-------------|-------------|
| 1-RTP-Part1 | 4.2            | na          | na          |
| 1-RTP-Part2 | 2.36           | na          | na          |
| 1-SurPRO-1  | 0              | -1.01       | 1.24        |

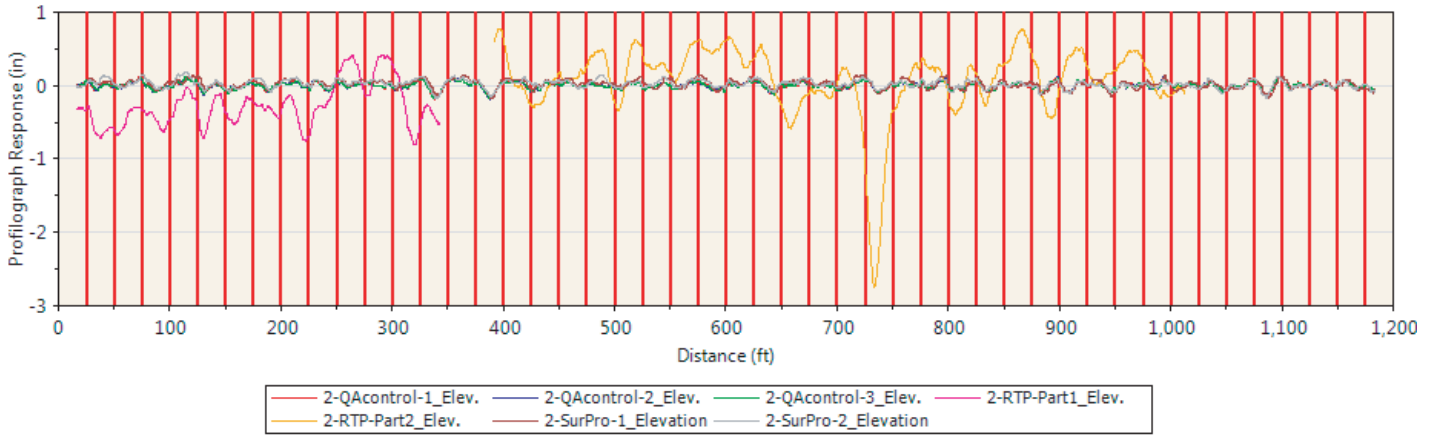
Note: na = not applicable.

<sup>a</sup>Relative offsets are in feet.

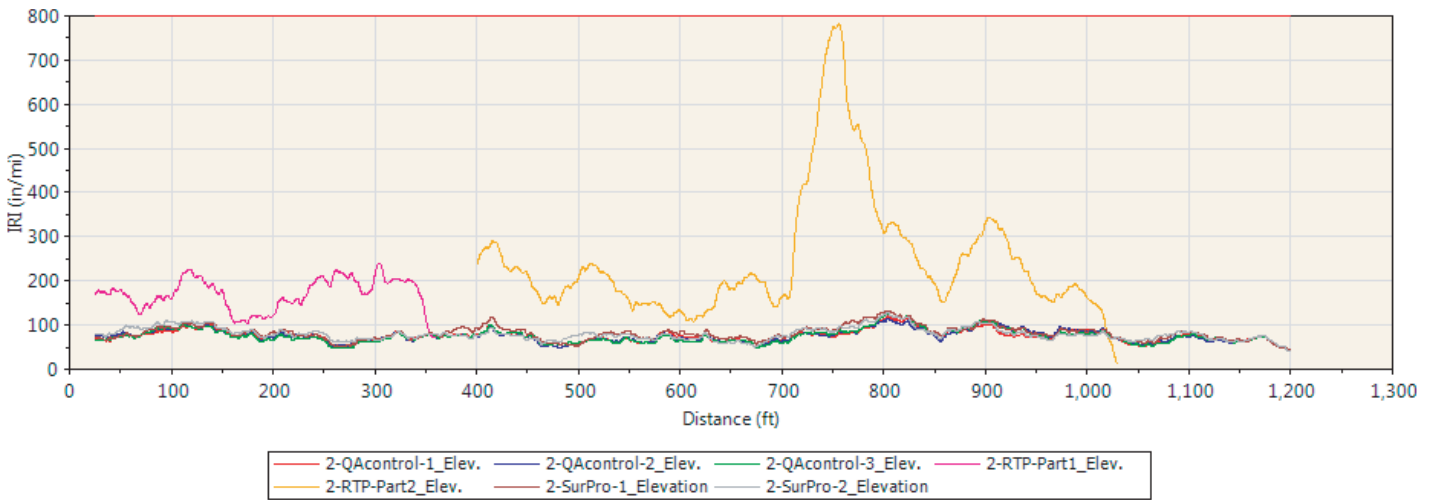


**Figure E.6. Profile elevations Path 2 (real time = RTP and hardened concrete).**





**Figure E.7. Profilograph simulation of Path 2 using a 0-in. blanking band.**



**Figure E.8. IRI of Path 2 (real time = RTP and hardened concrete).**

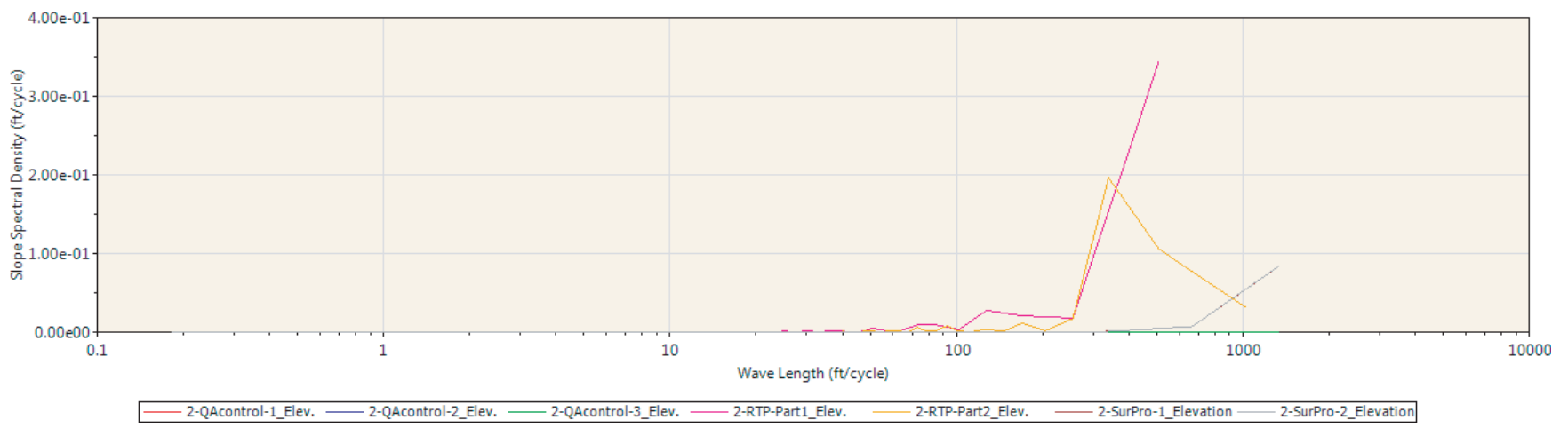


Figure E.9. Path 2 PSD.

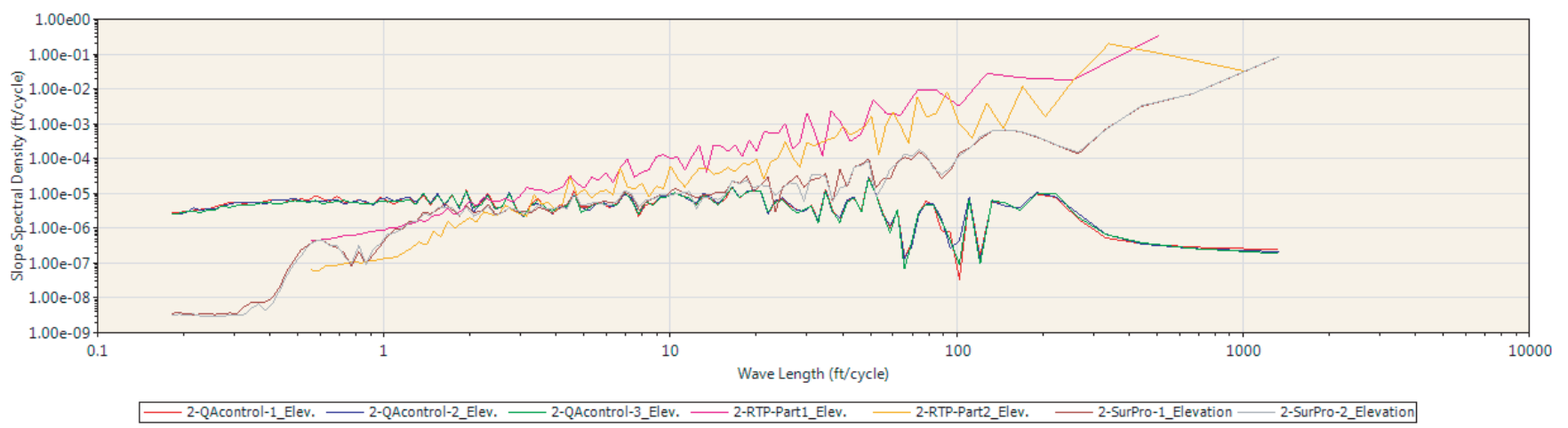


Figure E.10. Path 2 PSD, log scale.

**Table E.3. Path 2 Cross Correlation: Correlation Percentage (Column Used as Basis)**

|             | 2-QA Control-1 | 2-RTP-Part1 | 2-RTP-Part2 |
|-------------|----------------|-------------|-------------|
| 2-RTP-Part1 | 16.8           | na          | na          |
| 2-RTP-Part2 | -1.8           | na          | na          |
| 2-SurPRO-1  | 84.2           | 16.1        | -2.1        |

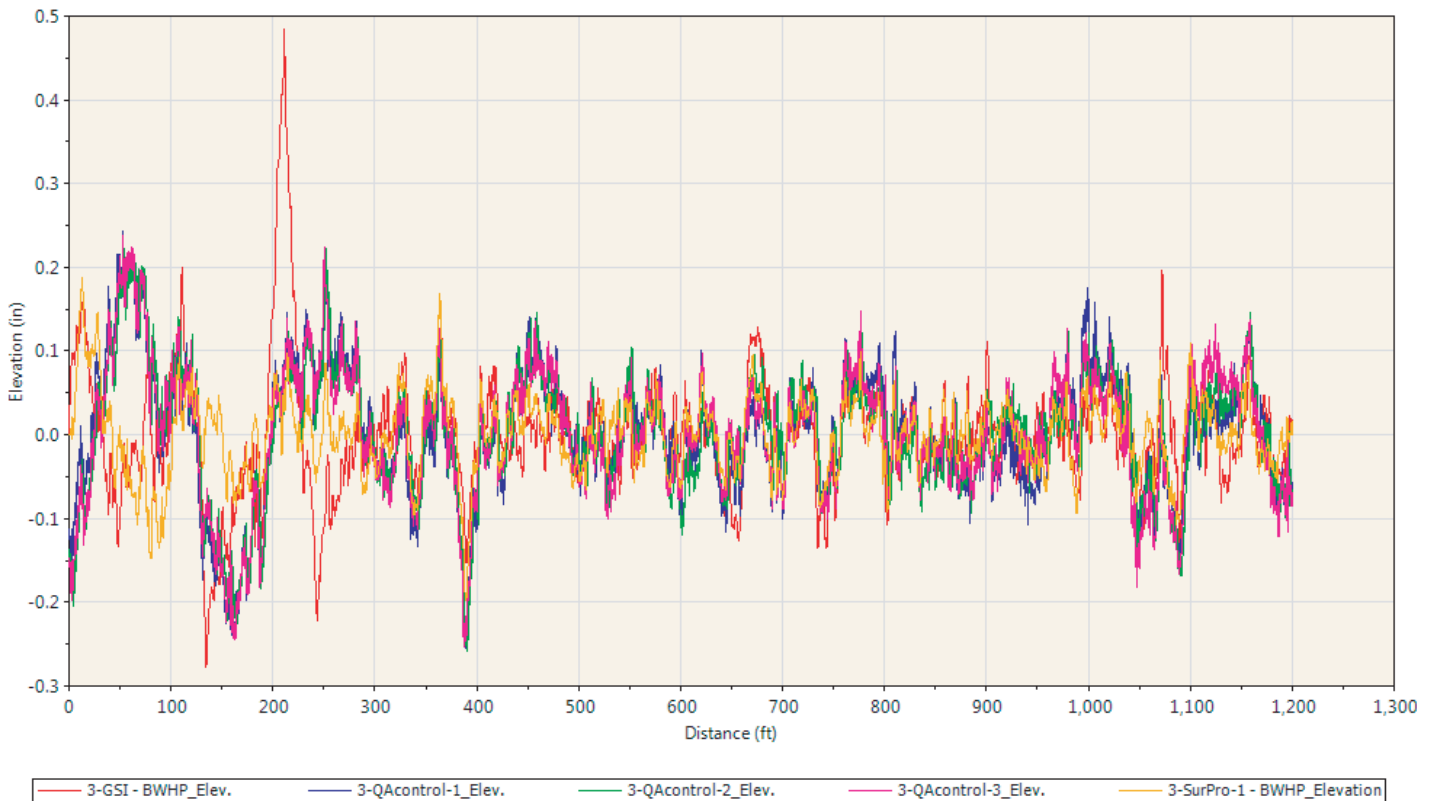
Note: na = not applicable.

**Table E.4. Path 2 Cross Correlation: Relative Offsets<sup>a</sup>**

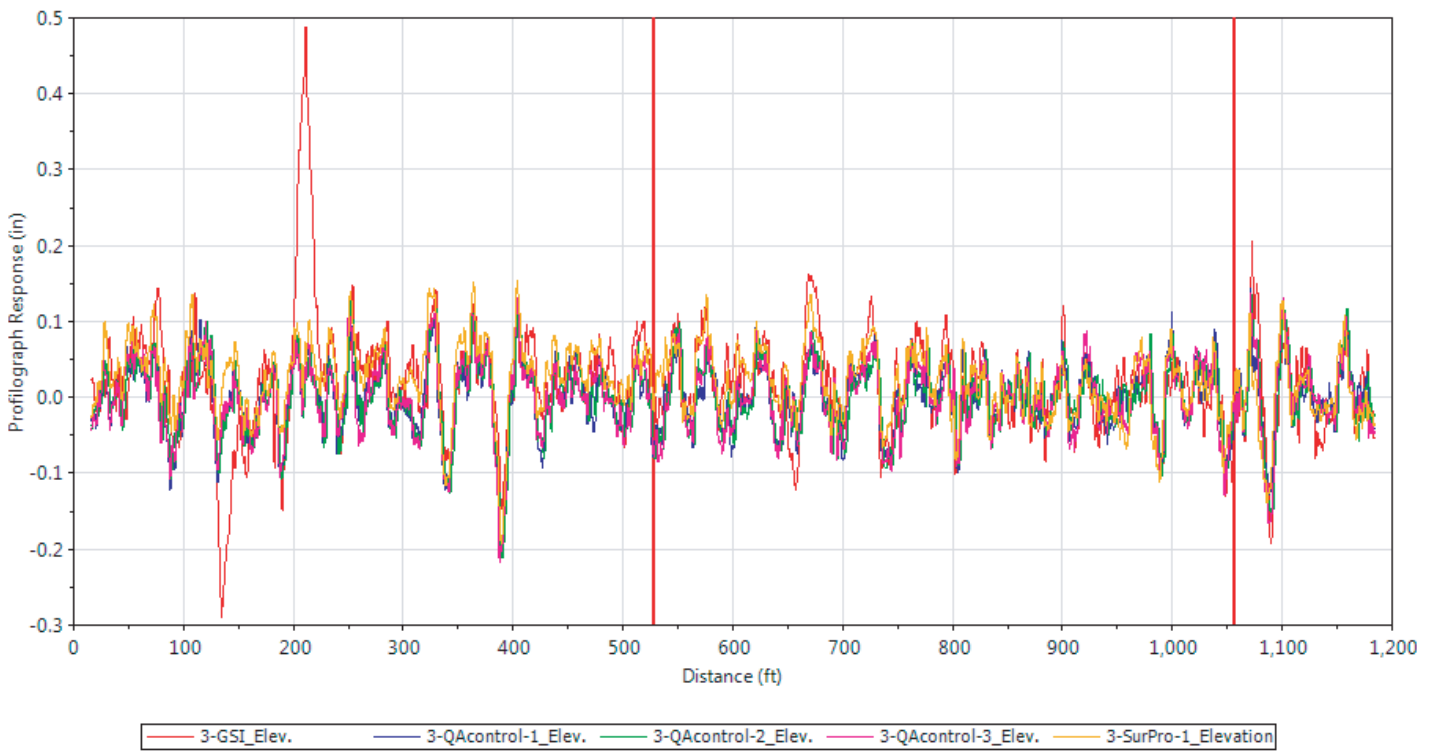
|             | 2-QA Control-1 | 2-RTP-Part1 | 2-RTP-Part2 |
|-------------|----------------|-------------|-------------|
| 2-RTP-Part1 | -0.24          | na          | na          |
| 2-RTP-Part2 | 0.25           | na          | na          |
| 2-SurPRO-1  | -1.38          | -1.75       | -2.00       |

Note: na = not applicable.

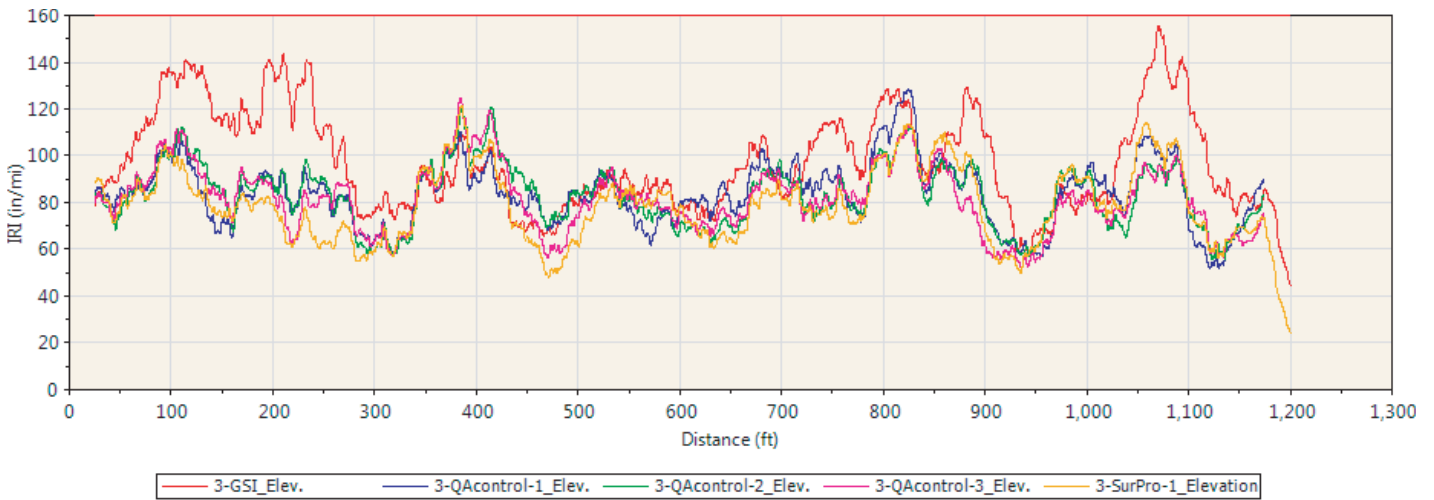
<sup>a</sup>Relative offsets are in feet.



**Figure E.11. Profile elevations Path 3 (real time = GSI and hardened concrete).**



**Figure E.12.** Profilograph simulation of Path 3 using a 0-in. blanking band.



**Figure E.13.** IRI of Path 3 (real time = GSI and hardened concrete).



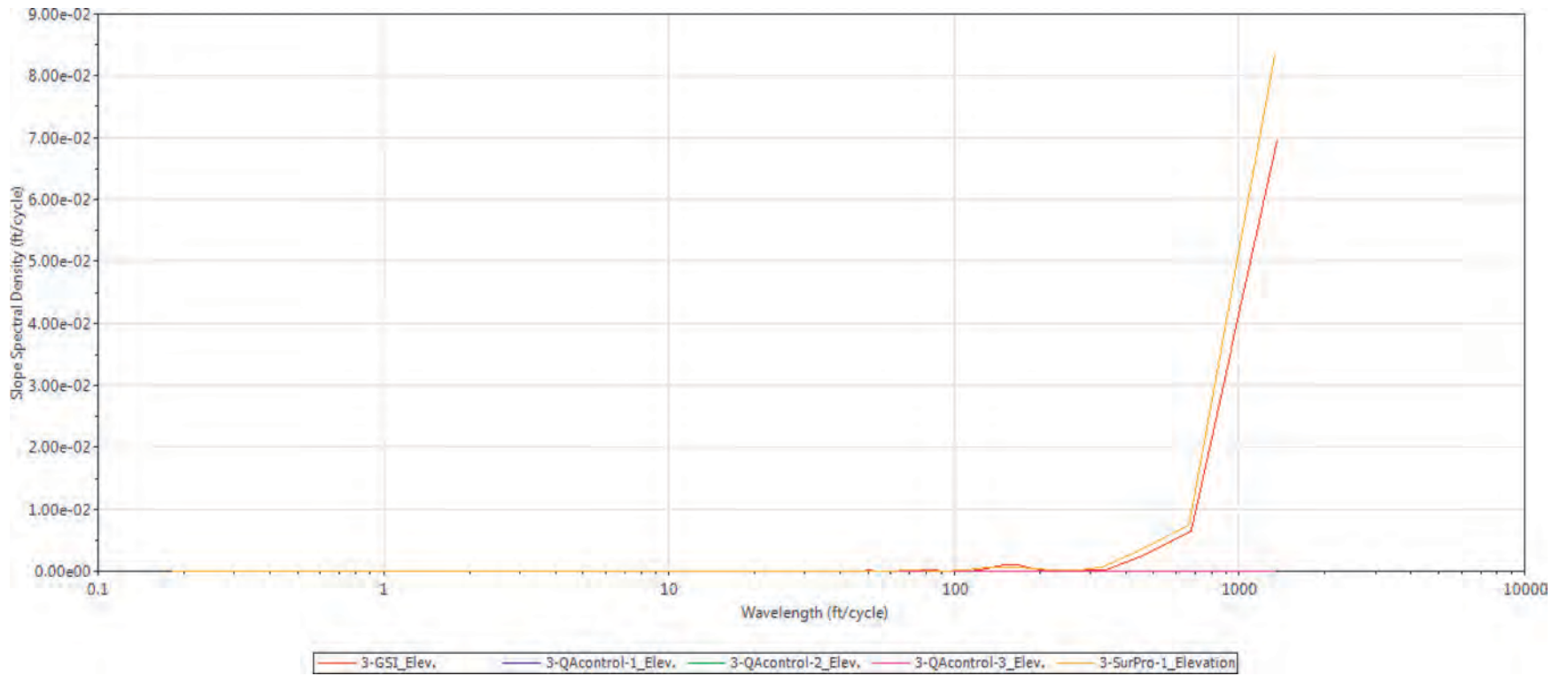


Figure E.14. Path 3 PSD.

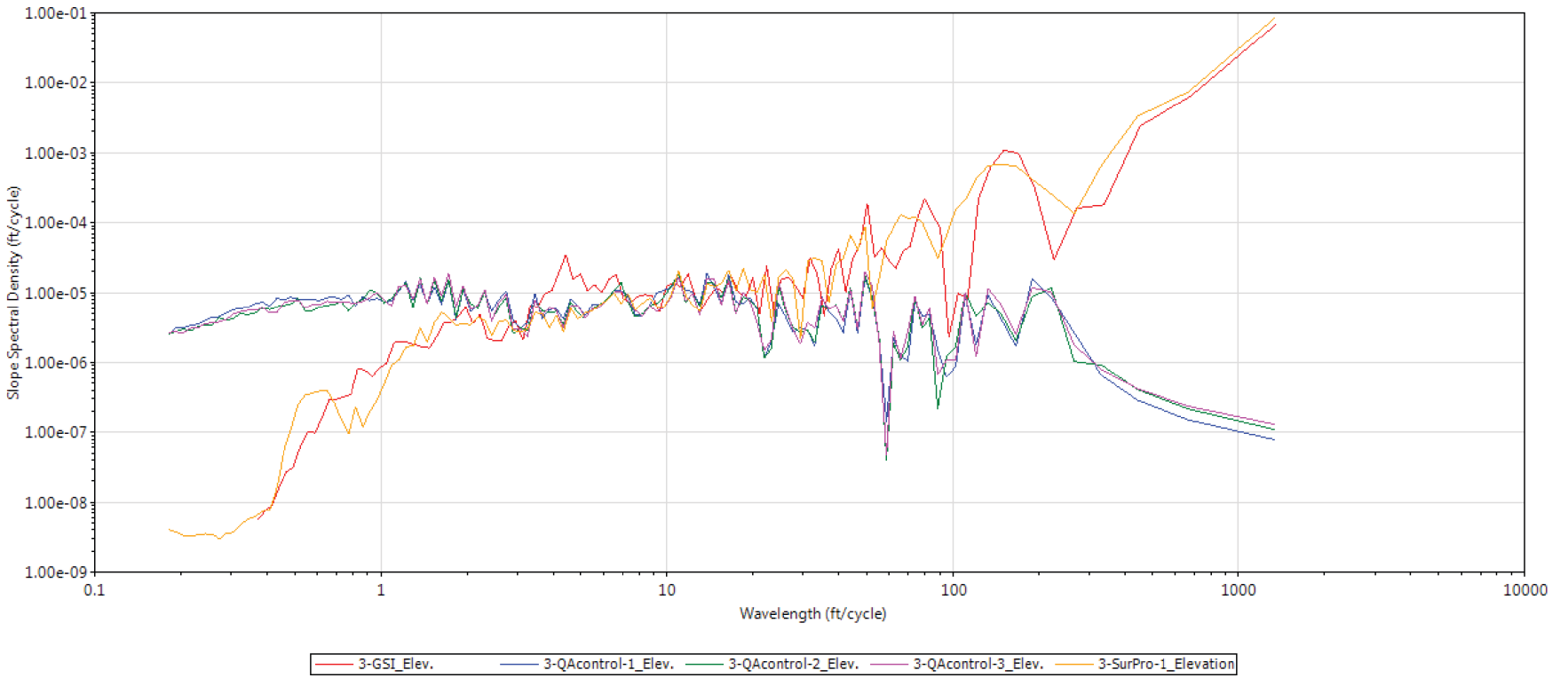


Figure E.15. Path 3 PSD, log scale.

**Table E.5. Path 3 Cross Correlation: Correlation Percentage (Column Used as Basis)**

|            | 3-QA Control-1 | 3-GSI |
|------------|----------------|-------|
| 3-GSI      | 32.8           | na    |
| 3-SurPRO-1 | 70.9           | 32.1  |

Note: na = not applicable.

**Table E.7. Path 4 Cross Correlation: Correlation Percentage (Column Used as Basis)**

|            | 4-QA Control-1 | 4-GSI |
|------------|----------------|-------|
| 4-GSI      | 30.4           | na    |
| 4-SurPRO-1 | 87.9           | 31.8  |

Note: na = not applicable.

**Table E.6. Path 3 Cross Correlation: Relative Offsets<sup>a</sup>**

|            | 3-QA Control-1 | 3-GSI |
|------------|----------------|-------|
| 3-GSI      | 0.08           | na    |
| 3-SurPRO-1 | 0.08           | 0.81  |

Note: na = not applicable.

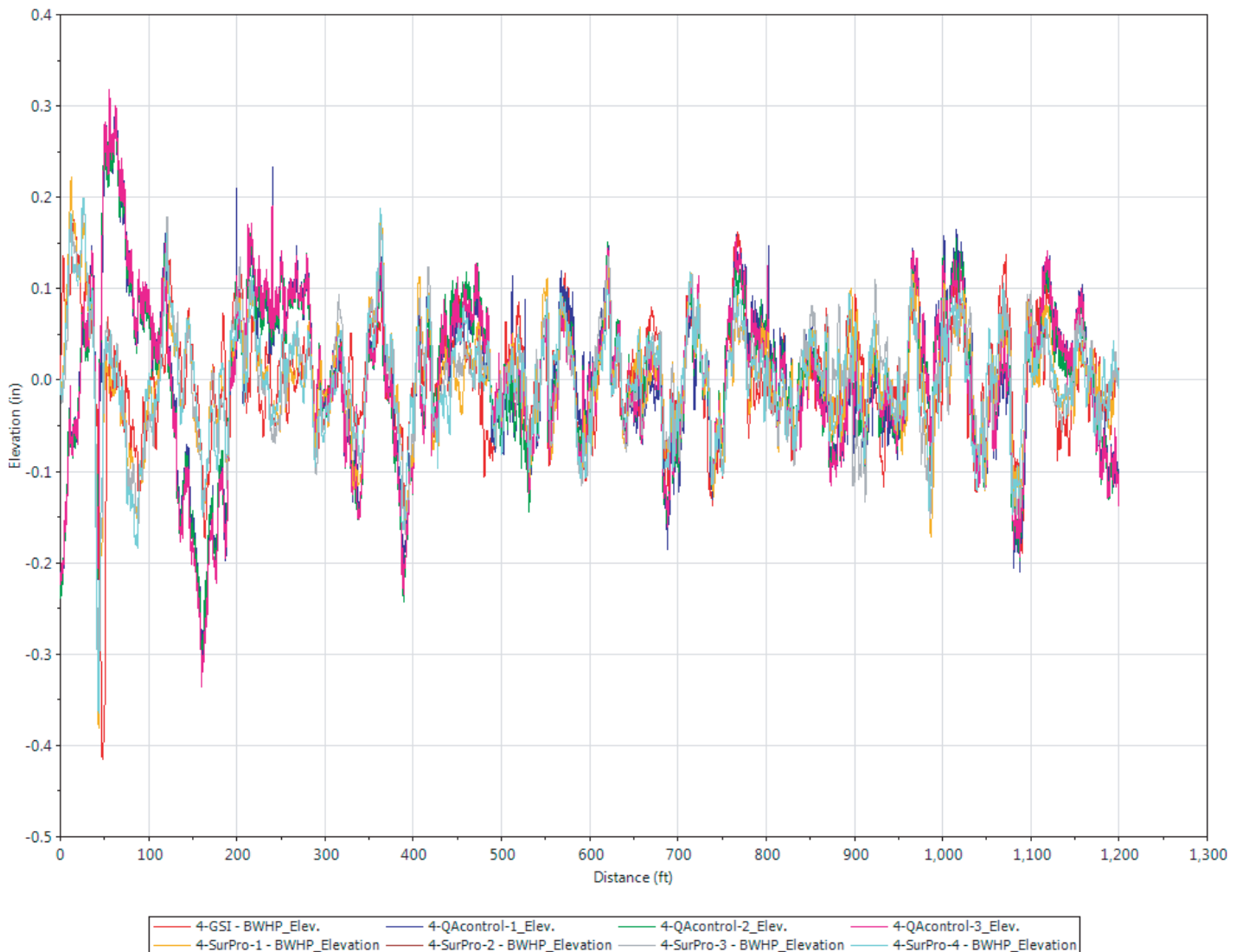
<sup>a</sup>Relative offsets are in feet.

**Table E.8. Path 4 Cross Correlation: Relative Offsets<sup>a</sup>**

|            | 4-QA Control-1 | 4-GSI |
|------------|----------------|-------|
| 4-GSI      | 0.17           | na    |
| 4-SurPRO-1 | -0.73          | -0.68 |

Note: na = not applicable.

<sup>a</sup>Relative offsets are in feet.



**Figure E.16. Profile elevations Path 4 (real time = GSI and hardened concrete).**

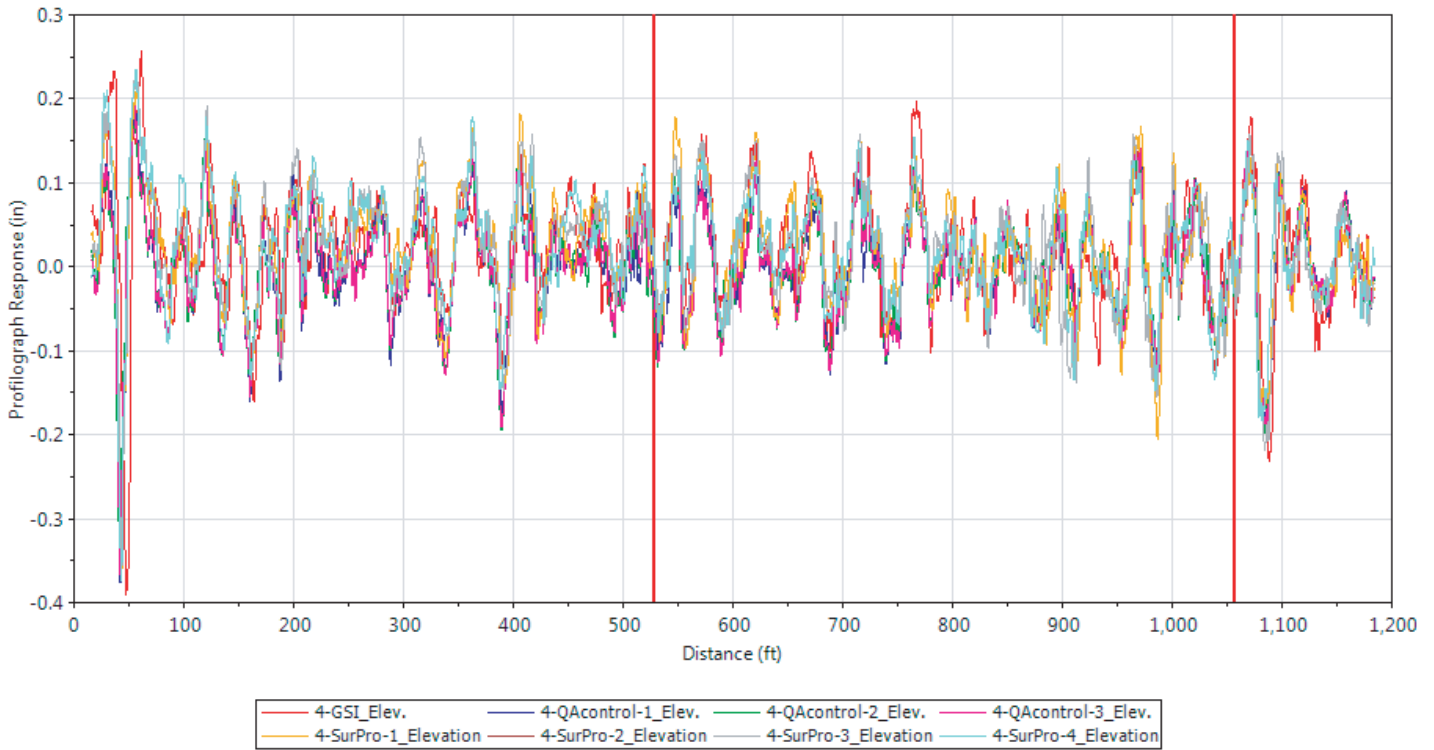


Figure E.17. Profilograph simulation of Path 4 using a 0-in. blanking band.

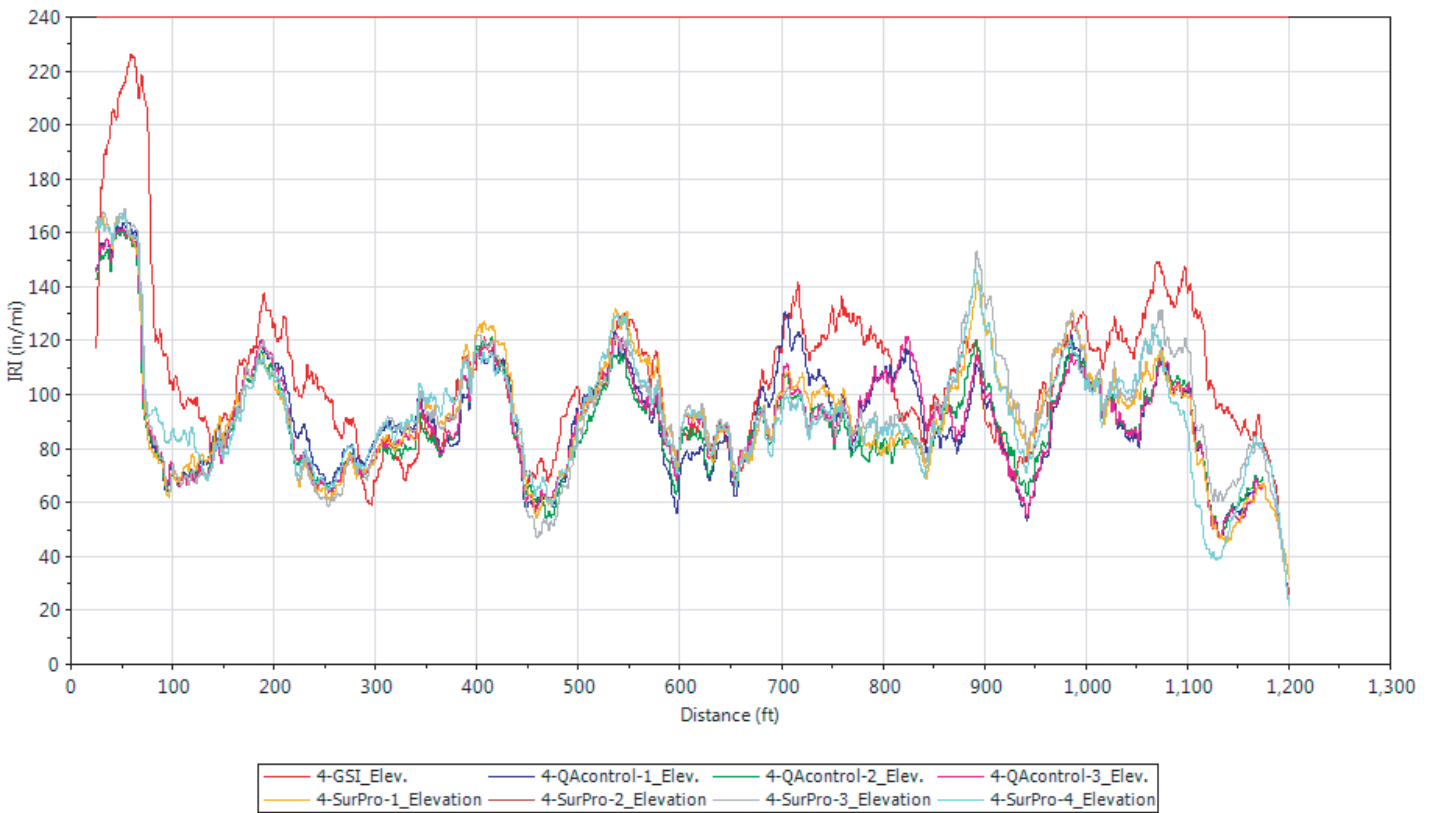


Figure E.18. IRI of Path 4 (real time = GSI and hardened concrete).



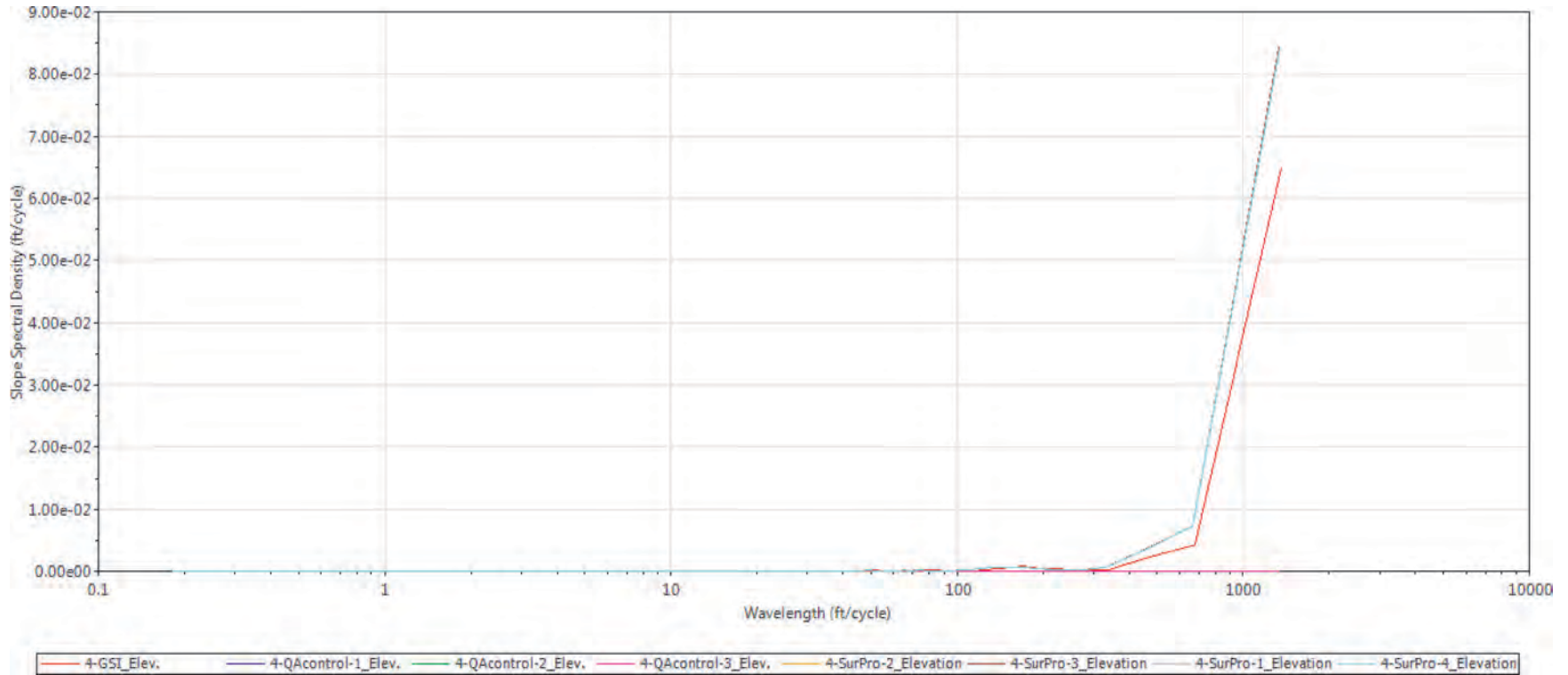


Figure E.19. Path 4 PSD.

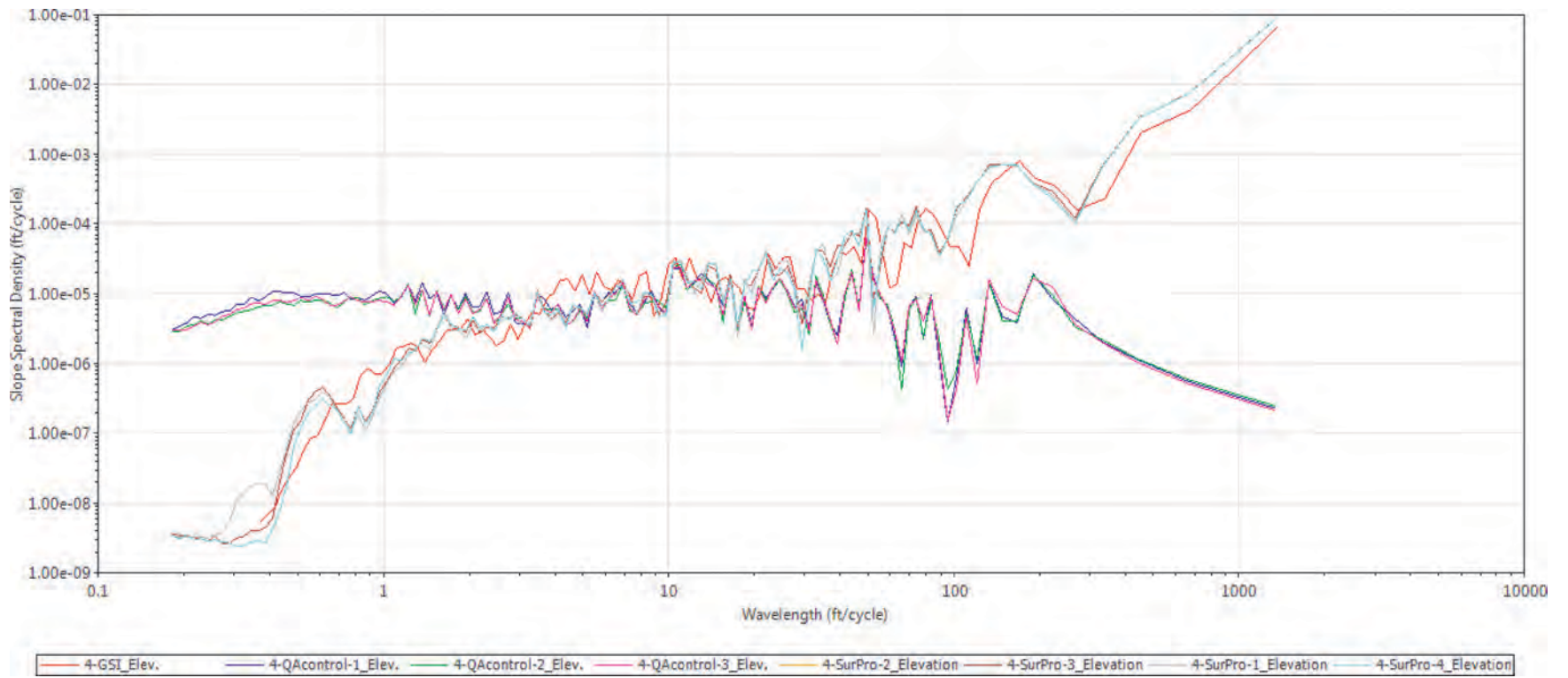


Figure E.20. Path 4 PSD, log scale.

## APPENDIX F

# Phase 3—New York Field Demonstration Data Reduction and Analysis

Appendix F contains data from the New York field demonstration. The figure plots, which are ProVAL screenshots, show profile elevations, profilograph simulations, ride quality analyses, and power spectral density analyses. Tables contain the cross-correlation data from ProVAL.

Figure F.1 plots elevation versus distance in the right wheelpath of the driving lane. One Ames Engineering Real Time Profiler (RTP) was mounted to the rear of the paver, and another RTP was mounted to the work bridge. Quality control (QC) data are also plotted.

Figure F.2 shows localized roughness of the right wheelpath of the driving lane based on a profilograph simulation with a 0-in. blanking band.

Figure F.3 plots the international roughness index (IRI) for each profile measured with the various profilers. The settings were for continuous IRI with 50-ft segments. The RTP-Paver shows a consistently higher IRI compared to the other profilers.

The power spectral density (PSD) analysis for the right wheelpath of the driving lane can be seen in Figure F.4. All profiles show a peak around 18 ft. The RTP-Paver also has significant peaks around 4.8 ft and 7.5 ft.

Figure F.5 shows the power spectral density for the right wheelpath of the driving lane as well, but with the log scale.

Values in Table F.1 are the correlation percentages between various profiler runs. A higher percentage means better correlation. Maximum correlation was between QC-Full-DriveRWP and RTP-Bridge. The least correlation was between RTP-Bridge and RTP-Paver. No results are provided in cases where both the row and the column pertain to the same device.

Values in Table F.2 show how many feet the comparison profile was shifted to best align with the basis profile. No results are provided in cases where both the row and the column pertain to the same device.

**Table F.1. Right Wheelpath Cross Correlation: Correlation Percentage (Column Used as Basis)**

|            | QC-Full-DriveRWP | RTP-Bridge |
|------------|------------------|------------|
| RTP-Bridge | 24.8             | na         |
| RTP-Paver  | 10.3             | 7.9        |

Note: na = not applicable.

**Table F.2. Right Wheelpath Cross Correlation: Relative Offsets<sup>a</sup>**

|            | QC-Full-DriveRWP | RTP-Bridge |
|------------|------------------|------------|
| RTP-Bridge | 8.09             | na         |
| RTP-Paver  | 21.91            | 15.81      |

Note: na = not applicable.

<sup>a</sup>Relative offsets are in feet.

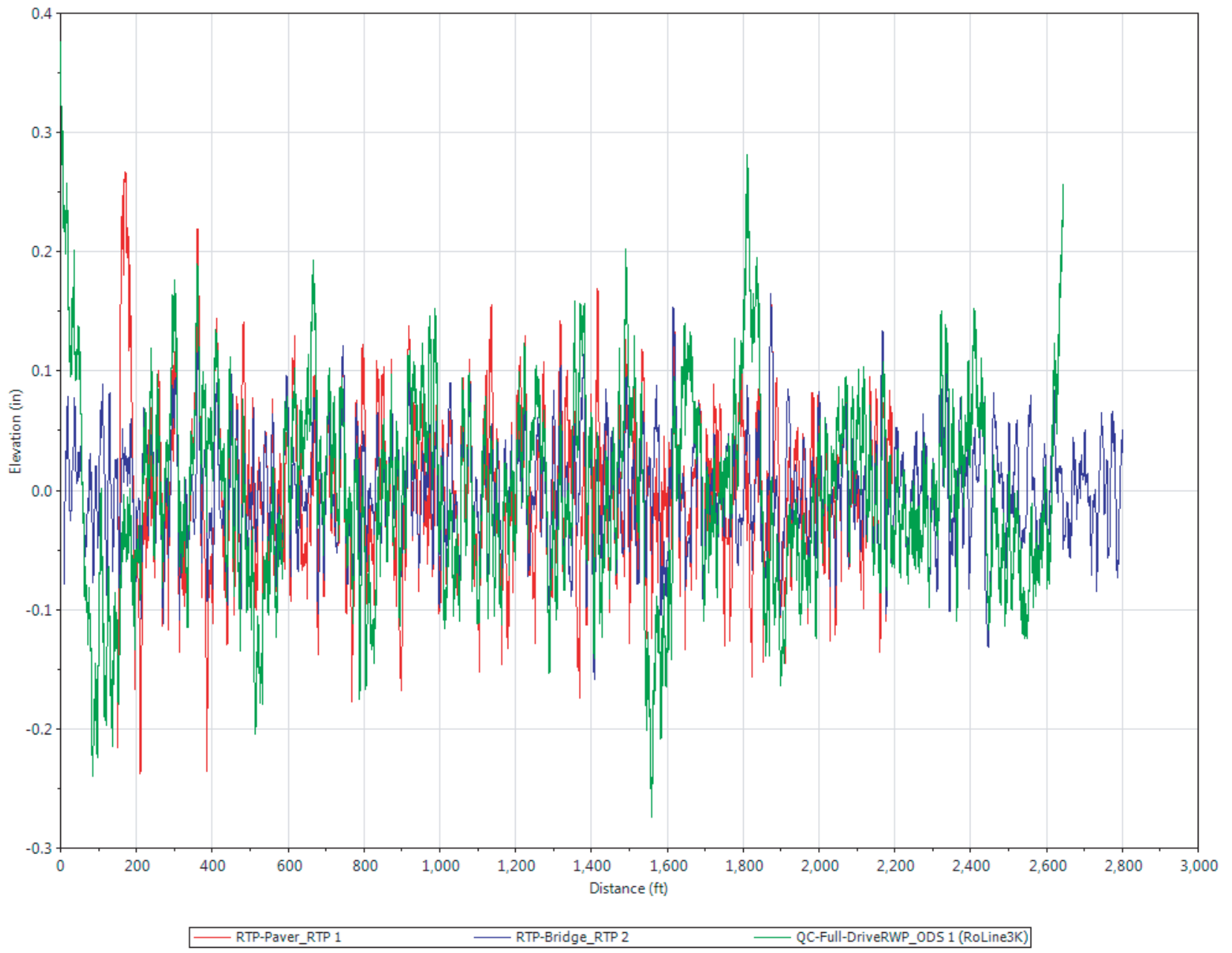
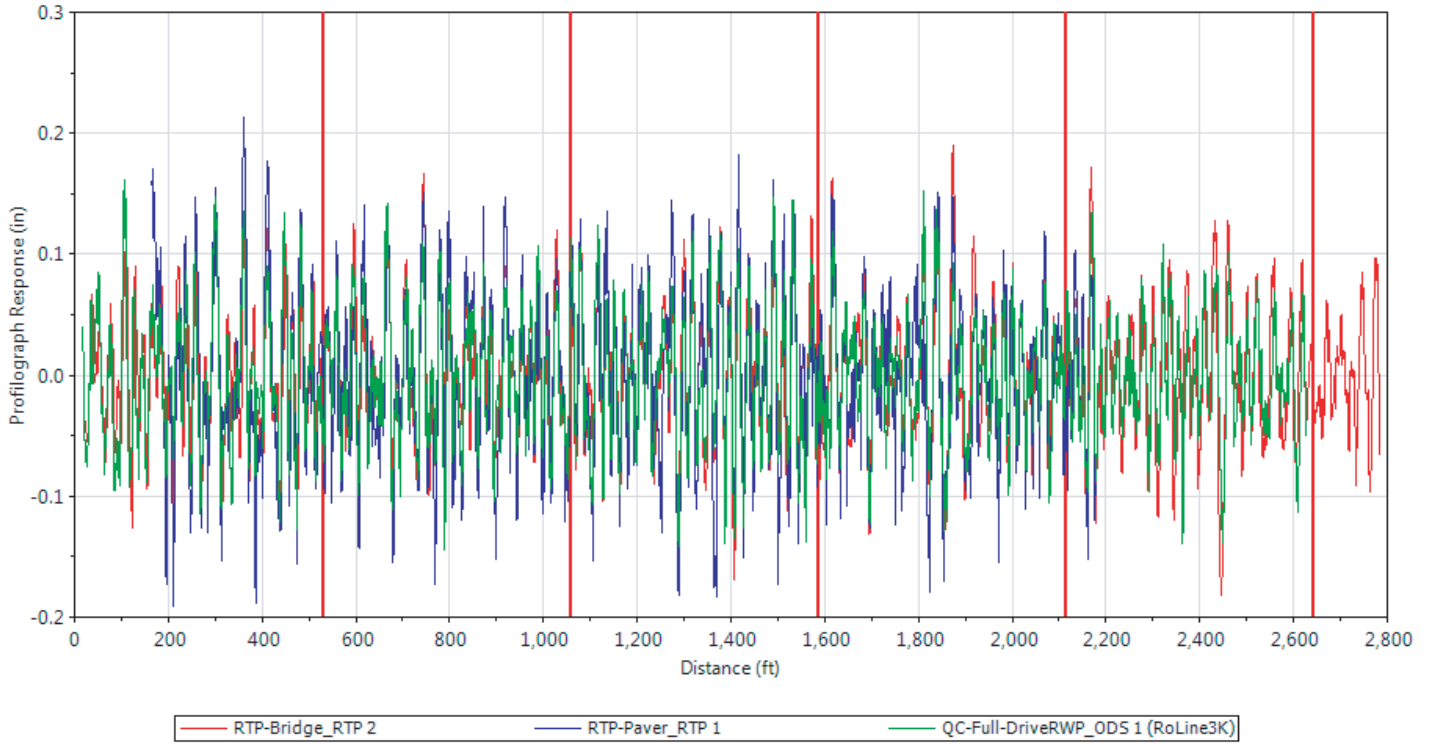
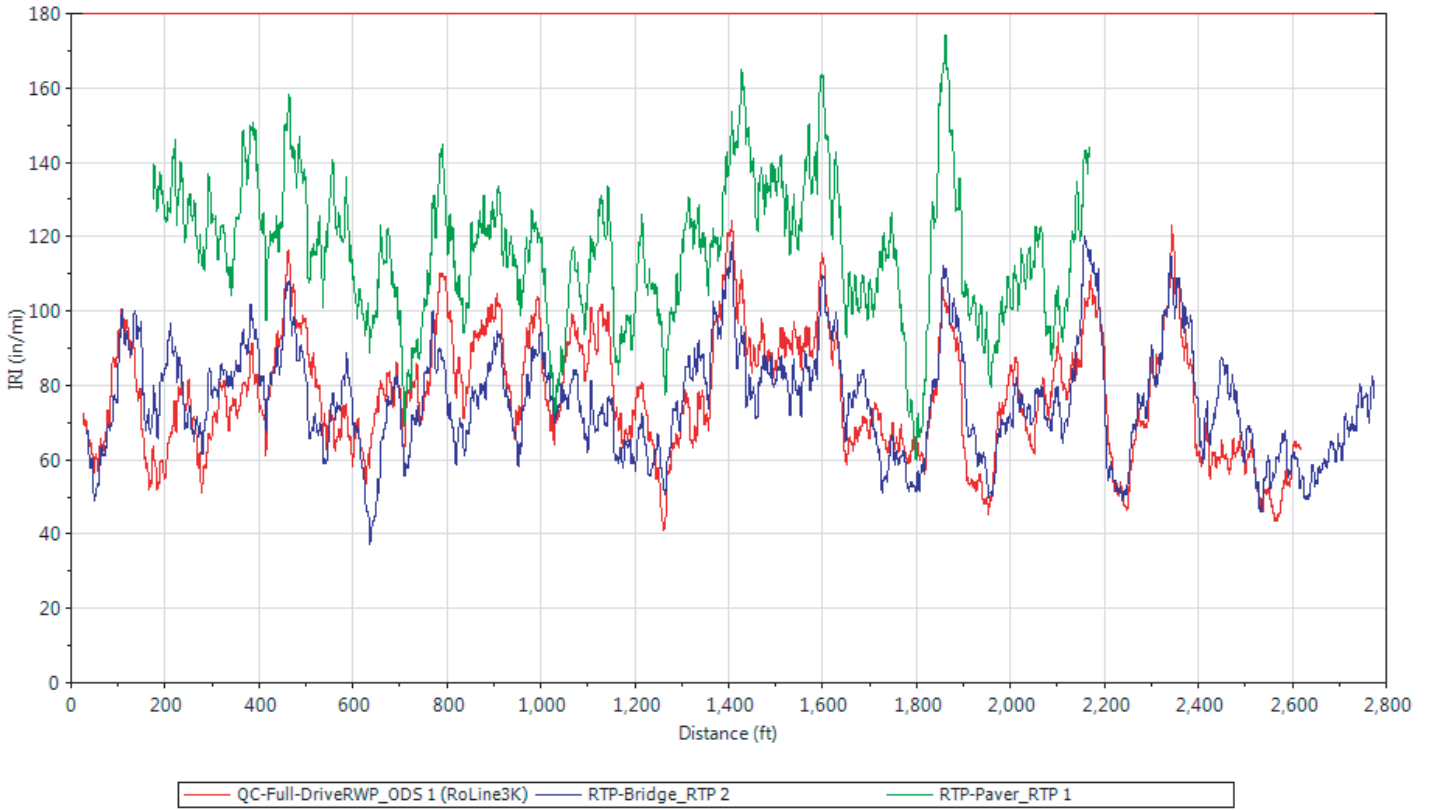


Figure F.1. Profile elevations right wheelpath (real time = RTP and hardened concrete).





**Figure F.2. Profilograph simulation of right wheelpath using a 0-in. blanking band.**



**Figure F.3. IRI of right wheelpath (real time = RTP and hardened concrete).**

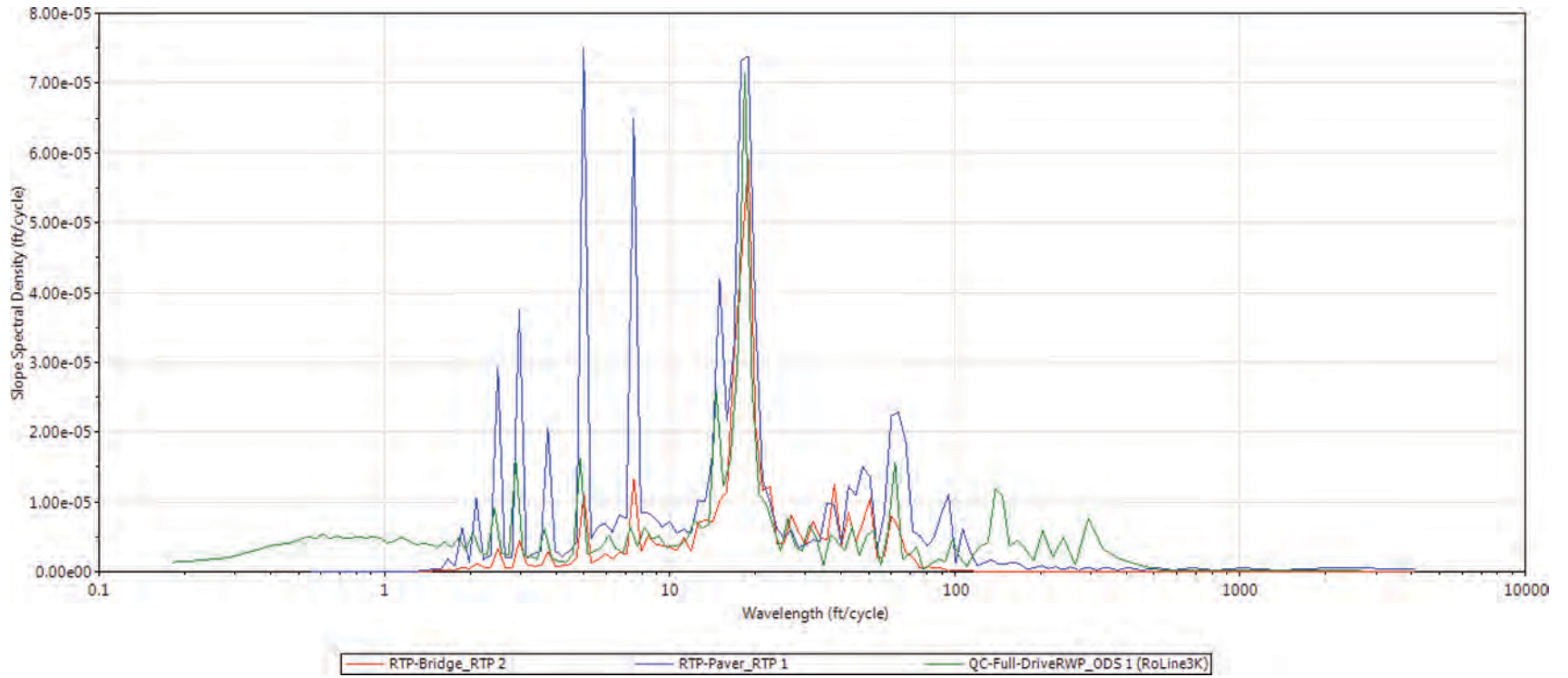


Figure F.4. Right wheelpath PSD.

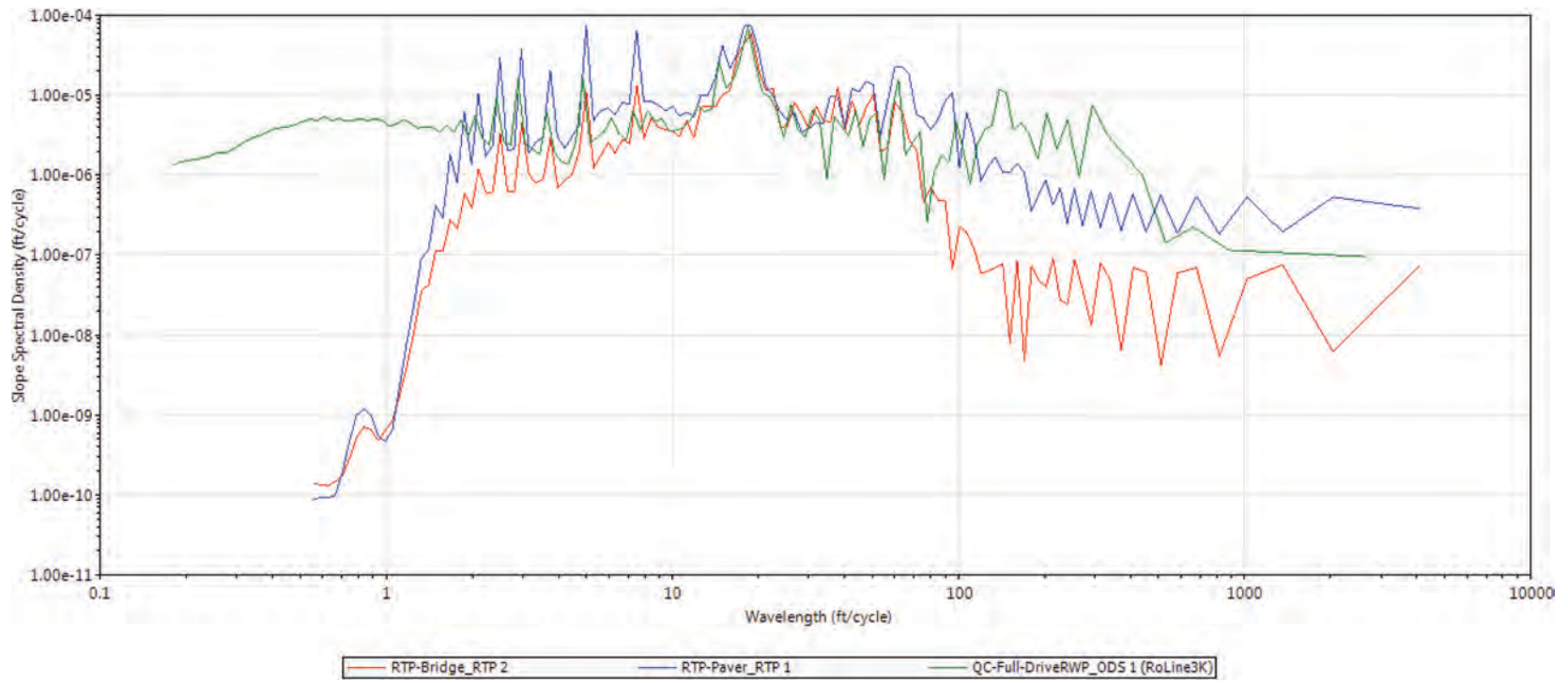


Figure F.5. Right wheelpath PSD, log scale.

## A P P E N D I X G

# Phase 3—Field Demonstrations: Additional Information

Appendix G presents additional information regarding the test sections for the field demonstrations in Phase 2 of this project. Specifically, more details regarding the paving operation, including photographs, are provided. Figures G.1 to G.8 present information related to the Arkansas demonstration.

Figure G.1 shows the typical section for the Vilonia Bypass project, which is the site for the first demonstration in Phase 3.

### Concrete Materials Data

The concrete mixture design used for this project called for Type ½ cement, 20% Class C fly ash, 60% crushed stone, 40% natural sand, a 0.43 water-to-cementitious materials ratio (w/cm), and 6% air. Figure G.2 lists mix design details for this project.

### Summary of Quality Control Test Data Provided by the Contractor

The following summary of test data (Figures G.3 to G.7) is provided for information only and as a means of characterizing the concrete materials that were evaluated during the real-time smoothness technology demonstration. Additionally, the contractor's normal quality control procedures include taking detailed notes that are recorded by two "ground men" who are responsible for paver operations and adjustments. These notes have been transcribed and are shown in Figure G.8.

Figures G.9 to G.13 present information related to the Texas demonstration.

### Concrete Materials Data

The concrete mixture design used for this project called for Type ½ cement; 35% Class C fly ash; an optimized blend of

crushed stone, pea gravel, and natural sand; 0.42 w/cm ratio; and 4.7% air. Figure G.9 lists mix design details for this project.

### Summary of Quality Control Test Data Provided by Contractor

Quality control testing of the concrete mixture placed on June 9, 2011, showed the concrete temperature to be 85°F with a slump of 1.5 in. and an air content of 4.9%. The following summary of aggregate gradation test data (Figures G.10 to G.13) is provided for information only and as a means of characterizing the concrete materials that were evaluated during the real-time smoothness technology demonstration. The analyses indicate the aggregates were well graded with a maximum aggregate size of 1.5 in. (nominal maximum aggregate size of 1 in.), workability factor of 34.0, and a coarseness factor of 57.7.

Figures G.14 to G.19 present information related to the Michigan demonstration.

### Concrete Mixture Design

Mixture design information is provided in Figure G.14.

### Summary of Quality Control Test Data Provided by Contractor

The following summary of test data (Figures G.15 to G.19) is provided for information only and as a means of characterizing the concrete materials that were used during the real-time smoothness technology demonstration.



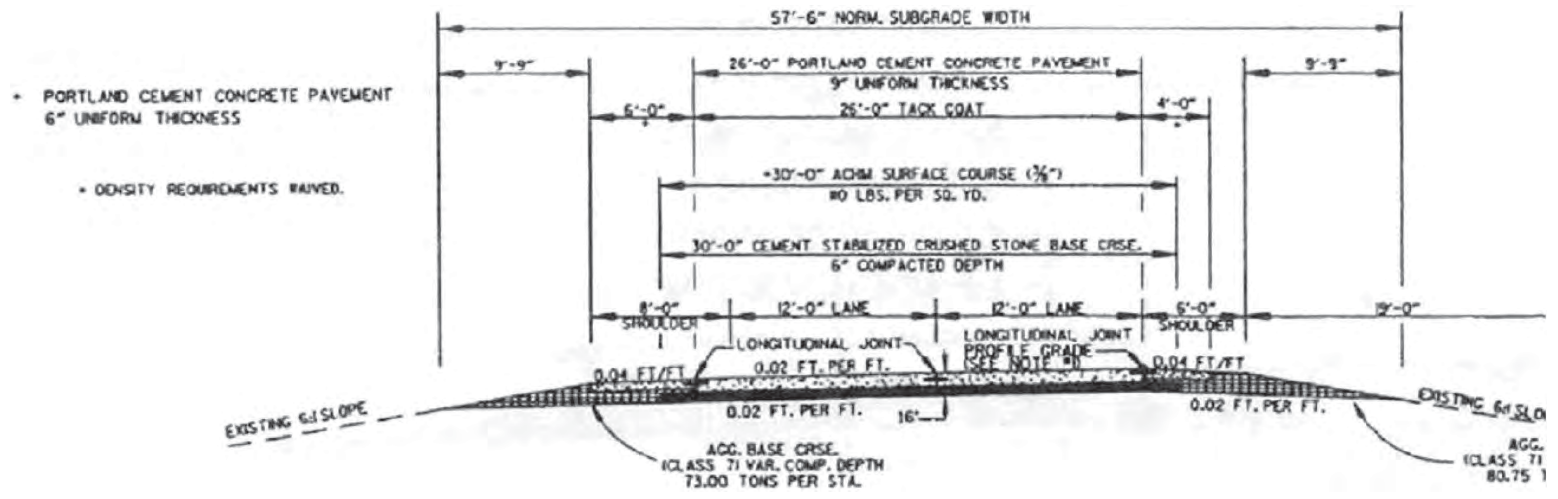


Figure G.1. Typical section of Vilonia Bypass.

| <b>Cementitious Materials</b> |                          | Source | Type  | Spec. Gravity | lb/yd <sup>3</sup>    | % Replacement by Mass |
|-------------------------------|--------------------------|--------|-------|---------------|-----------------------|-----------------------|
| Portland Cement:              | Ash Grove, Foreman, AR   | I/II   | 3.150 | 451           |                       |                       |
| GGBFS:                        |                          |        |       |               |                       |                       |
| Fly Ash:                      | Headwaters, Redfield, AR | C      | 2.610 | 113           |                       | 20.04%                |
| Silica Fume:                  |                          |        |       |               |                       |                       |
| Other Pozzolan:               |                          |        |       |               |                       |                       |
|                               |                          |        |       | 564           | lb/yd <sup>3</sup>    |                       |
|                               |                          |        |       | 6.0           | sacks/yd <sup>3</sup> |                       |

| <b>Aggregate Information</b> |                          | Source        | Type  | Spec. Gravity SSD | Absorption (%) |
|------------------------------|--------------------------|---------------|-------|-------------------|----------------|
| Coarse Aggregate:            | Wecco, El Paso, AR       | Crushed Stone | 2.617 | 1.50%             |                |
| Intermediate Aggregate:      |                          |               |       |                   |                |
| Fine Aggregate #1:           | Jeffrey Sand, Conway, AR | Natural       | 2.623 | 0.30%             |                |
| Fine Aggregate #2:           |                          |               |       |                   |                |

|   |        |
|---|--------|
| Coarse Aggregate %:                     | 60.1%  |
| Intermediate Aggregate %:               |        |
| Fine Aggregate #1 % of Total Fine Agg.: | 100.0% |
| Fine Aggregate #2 % of Total Fine Agg.: |        |
| Fine Aggregate #1 %:                    | 39.9%  |
| Fine Aggregate #2 %:                    |        |

| <b>Mix Proportion Calculations</b>  |       |
|-------------------------------------|-------|
| Water/Cementitious Materials Ratio: | 0.434 |
| Air Content:                        | 6.00% |

|                         | Volume (ft <sup>3</sup> )         | Batch Weights SSD (lb/yd <sup>3</sup> ) | Spec. Gravity | Absolute Volume (%) |
|-------------------------|-----------------------------------|---|---------------|---------------------|
| Portland Cement:        | 2.294                             | 451                                     | 3.150         | 8.50%               |
| GGBFS:                  |                                   |   |               |                     |
| Fly Ash:                | 0.694                             | 113                                     | 2.610         | 2.57%               |
| Silica Fume:            |                                   |   |               |                     |
| Other Pozzolan:         |                                   |   |               |                     |
| Coarse Aggregate:       | 11.107                            | 1,815                                   | 2.617         | 41.14%              |
| Intermediate Aggregate: |                                   |   |               |                     |
| Fine Aggregate #1:      | 7.362                             | 1,203                                   | 2.623         | 27.27%              |
| Fine Aggregate #2:      |                                   |   |               |                     |
| Water:                  | 3.923                             | 245                                     | 1.000         | 14.53%              |
| Air:                    | 1.620                             |   |               | 6.00%               |
|                         | 27.000                            | 3,827                                   |               | 100.00%             |
|                         | Unit Weight (lb/ft <sup>3</sup> ) | 141.7                                   |               |                     |

| <b>Admixture Information</b> | Source/Description |
|------------------------------|--------------------|
| Air Entraining Admix.:       | Euclid, AEA 92     |
| Admix. #1:                   | n/a                |

**Figure G.2. Arkansas concrete mixture design information.**

**AR US-64 Real-Time Smoothness Technology Demonstration  
Fresh Concrete Testing Summary**

| Date                | Sta.   | Conc. Temp. (°F) | Slump (in.) | Air Content (%) | Unit Weight (lb/ft <sup>3</sup> ) |
|---------------------|--------|------------------|-------------|-----------------|-----------------------------------|
| 5/10/2010           | 347+00 | 79.0             | 1.3         | 5.9             | NA                                |
| 5/10/2010           | 347+25 | 79.0             | 0.5         | 5.7             | 143.9                             |
| 5/10/2010           | 347+80 | 79.0             | 0.5         | 5.9             | 144.1                             |
| 5/10/2010           | 351+55 | 79.0             | 0.8         | 4.9             | 145.1                             |
| 5/10/2010           | 354+25 | 79.0             | 1.0         | 5.9             | 142.2                             |
| 5/10/2010           | 358+00 | 80.0             | 1.3         | 6.0             | 143.4                             |
| 5/10/2010           | 360+75 | 81.0             | 1.0         | 5.7             | 142.9                             |
| 5/10/2010           | 363+50 | 83.0             | 1.0         | 5.9             | 144.9                             |
| 5/10/2010           | 367+00 | 81.0             | 1.0         | 5.8             | 142.6                             |
| 5/10/2010           | 370+50 | 82.0             | 1.0         | 5.7             | 142.8                             |
| 5/10/2010           | 374+00 | 80.0             | 1.0         | 5.6             | 143.4                             |
| 5/10/2010           | 378+50 | 80.0             | 1.0         | 5.8             | 143.3                             |
| Average of All Data |        | 80.2             | 0.9         | 5.7             | 143.5                             |

Note: Average compressive strength at 28 days from previous paving is 4,590 psi.  
Conc. = concrete, NA = not available.

**Figure G.3. Summary of concrete test results for Arkansas site.**

Project: F.A.P. No. STM-ARR2(45), NH-0023(40) & TCSP-09AR(2); AHTD Job 080307  
 Mix ID: IHPC-02  
 Sample Comments: Average of 3 Sieve Analyses from 5-10-2011  
 Test Date: 10-May-11

Total Cementitious Material: 564 lb/yd<sup>3</sup>  
 Agg. Ratios: 60.10% 39.90% 100.00%

| Sieve  | Coarse | Intermediate #1 | Intermediate #2 | Fine #1 | Combined % Retained | Combined % Retained On Each Sieve | Combined % Passing |
|--------|--------|-----------------|-----------------|---------|---------------------|-----------------------------------|--------------------|
| 2 1/2" | na     | na              | na              | na      | 0%                  | 0%                                | 100%               |
| 2"     | na     | na              | na              | na      | 0%                  | 0%                                | 100%               |
| 1 1/2" | na     | na              | na              | na      | 0%                  | 0%                                | 100%               |
| 1"     | na     | na              | na              | na      | 0%                  | 0%                                | 100%               |
| 3/4"   | na     | na              | na              | na      | 12%                 | 12%                               | 88%                |
| 1/2"   | na     | na              | na              | na      | 32%                 | 20%                               | 68%                |
| 3/8"   | na     | na              | na              | na      | 41%                 | 11%                               | 59%                |
| #4     | na     | na              | na              | na      | 57%                 | 16%                               | 43%                |
| #8     | na     | na              | na              | na      | 61%                 | 4%                                | 39%                |
| #16    | na     | na              | na              | na      | 66%                 | 5%                                | 34%                |
| #30    | na     | na              | na              | na      | 77%                 | 11%                               | 23%                |
| #50    | na     | na              | na              | na      | 96%                 | 19%                               | 4%                 |
| #100   | na     | na              | na              | na      | 99%                 | 3%                                | 1%                 |
| #200   | na     | na              | na              | na      | 99.0%               | 0.0%                              | 1.0%               |

Workability Factor: 39.0  
 Coarseness Factor: 67.2

Note: na = not applicable.

Figure G.4. Sieve analysis test data (combined gradation) for Arkansas site.

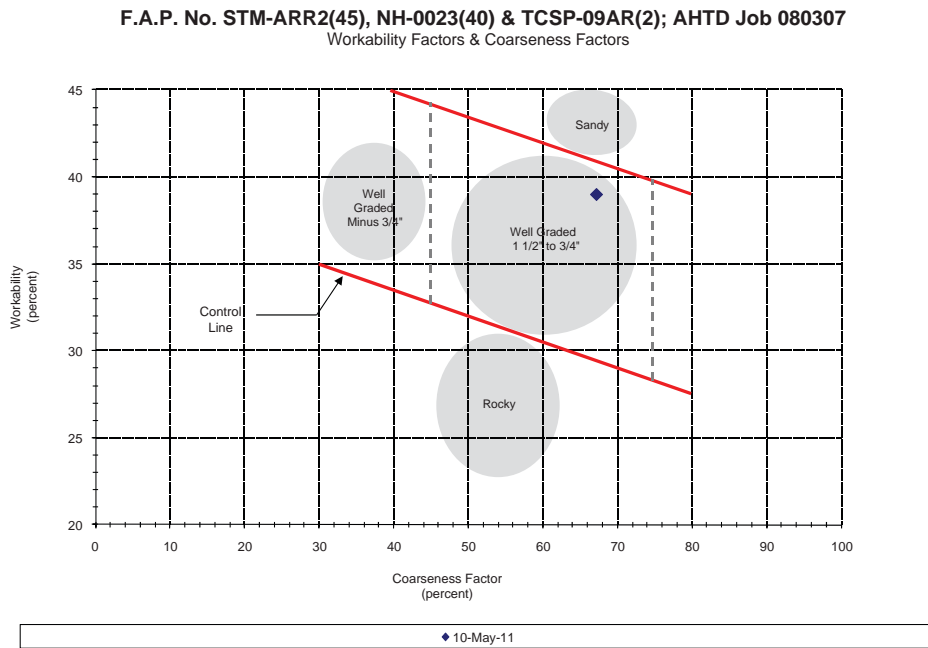


Figure G.5. Combined gradation coarseness and workability factors for Arkansas site.

F.A.P. No. STM-ARR2(45), NH-0023(40) & TCSP-09AR(2); AHTD Job 080307  
 Combined Percent Retained "8-18" & "6-22" Limits

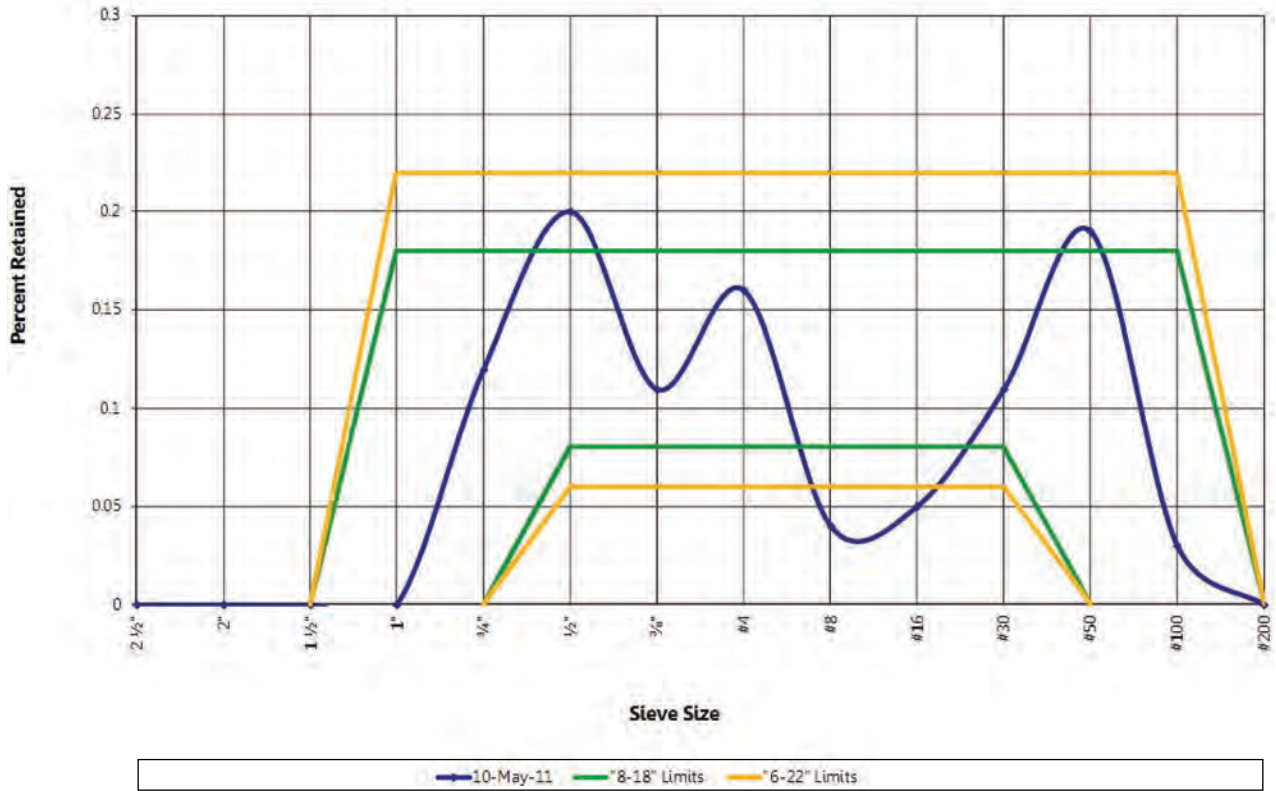


Figure G.6. Combined percent retained on individual sieves for Arkansas site.

Figures G.20 to G.26 present information related to the New York demonstration. Figure G.20 shows the typical section for the Interchange 39-40 reconstruction project, which is the site for the fourth demonstration in Phase 3.

### Concrete Mixture Design

Mixture design information is provided in Figure G.21.

### Summary of Quality Control Test Data Provided by Contractor

The following summary of test data (Figures G.22 to G.26) is provided for information only and as a means of characterizing the concrete materials that were used during the real-time smoothness technology demonstration.



**F.A.P. No. STM-ARR2(45), NH-0023(40) & TCSP-09AR(2); AHTD Job 080307**

0.45 Power Curve

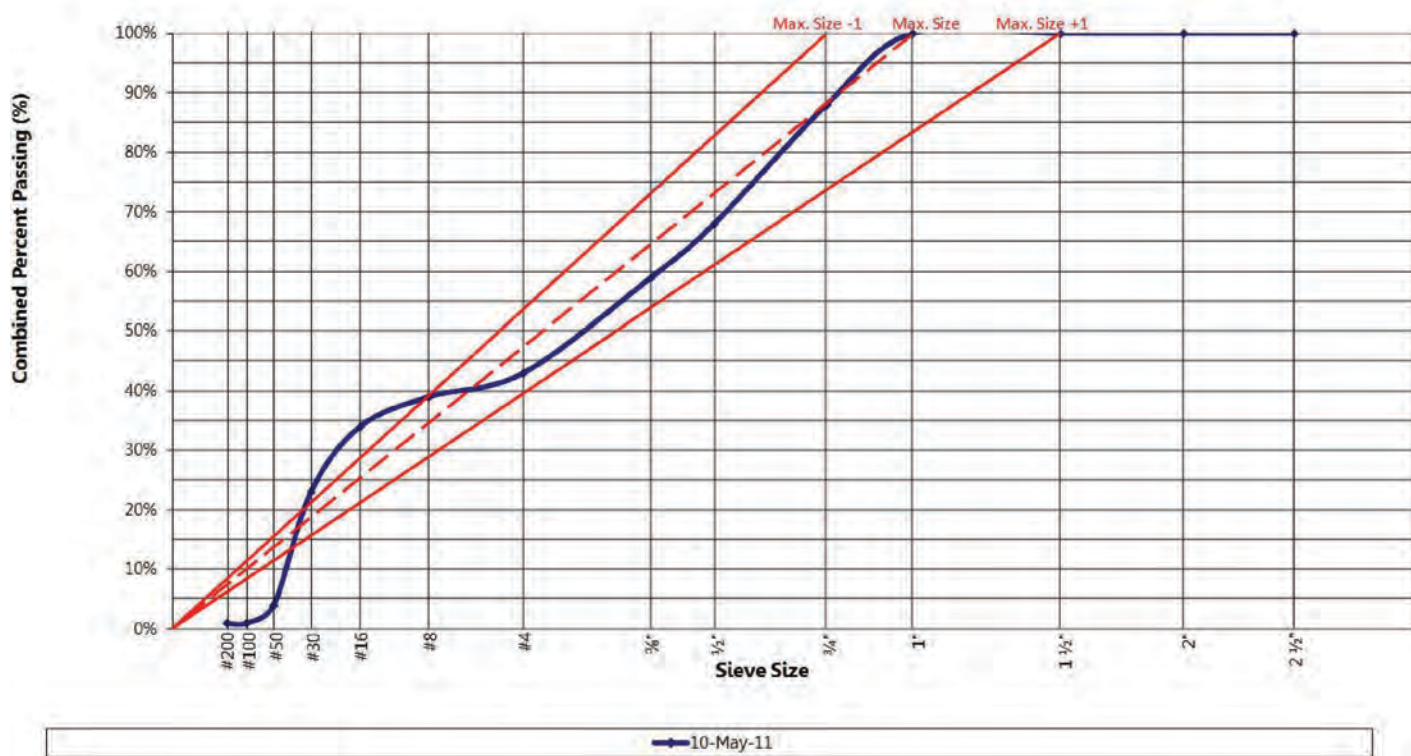


Figure G.7. Plot of the 0.45 power curve for Arkansas site.

| Sta.   | Notes   |
|--------|---|
| 348+00 | paver out of super in to transition   |
| 349+00 | ADJ paver on right side so that I could get the 12' I need on profile, crank down one |
| 349+50 | paver stopped because of TBI  |
| 349+50 | Lusio hit me — on right side with his habalina  |
| 350+00 | RF steering sensor wand hit dowel bar bundle  |
| 350+50 | crank down one on right side  |
| 353+00 | paver stopped to fuel   |
| 354+00 | paver was over loaded   |
| 354+00 | roll size of OCB 1' in  |
| 354+50 | Martin speeded up paver a bit 8' 4" fpm   |
| 354+85 | paver stopped   |
| 355+50 | mud box is about half full only   |
| 355+75 | paver stopped   |
| 356+00 | paver stopped so we can lower edge on left side                                       |
| 356+30 | wet loads   |
| 356+14 | paver is now tracking on asphalt on left side   |
| 356+15 | paver stopped   |
| 356+50 | paver stopped because paver was running low on mud                                    |
| 356+55 | roll size about 10 1/2" on OCB also wet loads   |
| 357+00 | paver no longer running low on mud  |
| 357+50 | paver stopped because of TBI  |
| 357+75 | truck hit line on left side   |
| 358+00 | good mud in front of paver no longer too wet  |
| 358+75 | crank up one on right side to get a foot on profile                                   |
| 358+75 | wet loads   |
| 358+90 | mud box about 1/2 way full  |
| 359+50 | OCB roll is bigger on right side than left  |
| 359+95 | paver stopped because of DBI  |
| 360+40 | paver stopped for DBI   |
| 360+50 | paver is about 3/4 full in the mud box  |
| 360+75 | paver stopped so he can change edges  |
| 361+00 | mud too wet   |
| 361+00 | paver is no longer tracking on asphalt on left side. OCB roll is about 1' in size     |
| 361+25 | paver stopped, no trucks  |
| 362+25 | paver stopped because of DBI  |
| 363+00 | lower sensitivity on right side to match left side                                    |
| 364+25 | paver stopped, no trucks  |
| 364+50 | paver stopped because of TBI  |
| 364+75 | paver stopped because of DBI  |
| 365+00 | paver stopped because TBI   |
| 365+03 | paver stopped because TBI   |
| 365+75 | paver stopped because TBI   |
| 366+00 | mud a little too wet  |
| 366+10 | paver stopped, mud was low in front of paver  |
| 367+00 | paver stopped because of trucks   |
| 369+25 | paver stopped because of trucks   |
| 370+00 | wet loads   |
| 370+25 | paver stopped because of side bars on right side                                      |
| 372+25 | no trucks, paver stopped  |
| 372+66 | paver stop because of DBI   |
| 374+25 | mud is looking better, not so wet   |
| 375+70 | paver stopped, no trucks  |
| 375+75 | wet loads   |
| 376+00 | paver is paving at 7 fpm. No more water   |
| 376+50 | side forms no longer on float or right side   |
| 376+60 | paver stopped because of TBI  |
| 376+75 | paver stopped to fuel and put some more water in the tank                             |
| 377+25 | lowered strike off on right side  |
| 377+50 | paver stopped   |
| 378+00 | mud box low   |
| 378+00 | paver stopped because of a dowel that fell between RR track                           |
| 378+25 | paver overloaded on right side  |
| 378+50 | mud not so wet, look good to me   |
| 379+25 | mud box ran low   |
| 380+25 | paver stopped, also Andy hit line   |
| 380+88 | paver stopped   |

**Figure G.8. Interstate Highway Construction ground men notes.**

| <b>Cementitious Materials</b> |                 |               |                    |                        |
|-------------------------------|-----------------|---------------|--------------------|------------------------|
| Source                        | Type            | Spec. Gravity | lb/yd <sup>3</sup> | % Replacement by Mass  |
| Portland Cement:              | Cemex, Balcones | I/II          | 3.150              | 293                    |
| GGBFS:                        |                 |               |                    |                        |
| Fly Ash:                      | Cemex, TMPA     | C             | 2.690              | 158                    |
| Silica Fume:                  |                 |               |                    | 35.03%                 |
| Other Pozzolan:               |                 |               |                    |                        |
|                               |                 |               | 451                | lb/ yd <sup>3</sup>    |
|                               |                 |               | 4.8                | sacks/ yd <sup>3</sup> |

| <b>Aggregate Information</b> |                        |                   |                |       |
|------------------------------|------------------------|-------------------|----------------|-------|
| Source                       | Type                   | Spec. Gravity SSD | Absorption (%) |       |
| Coarse Aggregate:            | Martin Marietta, Chico | Crushed Stone     | 2.642          | 0.90% |
| Intermediate Aggregate:      | Hanson, Bristol        | Pea Gravel        | 2.658          | 1.5%  |
| Fine Aggregate #1:           | Hanson, Bristol        | Natural           | 2.633          | 0.90% |
| Fine Aggregate #2:           |                        |                   |                |       |

|   |        |
|---|--------|
| Coarse Aggregate %:                     | 43.0%  |
| Intermediate Aggregate %:               | 14.0%  |
| Fine Aggregate #1 % of Total Fine Agg.: | 100.0% |
| Fine Aggregate #2 % of Total Fine Agg.: |        |
| Fine Aggregate #1 %:                    | 43.0%  |
| Fine Aggregate #2 %:                    |        |

| <b>Mix Proportion Calculations</b>  |       |
|-------------------------------------|-------|
| Water/Cementitious Materials Ratio: | 0.419 |
| Air Content:                        | 4.70% |

|                         | Volume (ft <sup>3</sup> )         | Batch Weights SSD (lb/ yd <sup>3</sup> ) | Spec. Gravity | Absolute Volume (%) |
|-------------------------|-----------------------------------|--|---------------|---------------------|
| Portland Cement:        | 1.491                             | 293                                      | 3.150         | 5.52%               |
| GGBFS:                  |                                   |  |               |                     |
| Fly Ash:                | 0.941                             | 158                                      | 2.690         | 3.49%               |
| Silica Fume:            |                                   |  |               |                     |
| Other Pozzolan:         |                                   |  |               |                     |
| Coarse Aggregate:       | 8.716                             | 1,435                                    | 2.642         | 32.28%              |
| Intermediate Aggregate: | 2.838                             | 470                                      | 2.658         | 10.51%              |
| Fine Aggregate #1:      | 8.716                             | 1,430                                    | 2.633         | 32.28%              |
| Fine Aggregate #2:      |                                   |  |               |                     |
| Water:                  | 3.028                             | 189                                      | 1.000         | 11.22%              |
| Air:                    | 1.269                             |  |               | 4.70%               |
|                         | 27.000                            | 3,975                                    |               | 100.00%             |
|                         | Unit Weight (lb/ft <sup>3</sup> ) | 147.2                                    |               |                     |

| <b>Admixture Information</b> |                            |
|------------------------------|----------------------------|
| Source/Description           |                            |
| Air Entraining Admix.:       | Chryso Air 260             |
| Admix. #1:                   | MRWR - Chryso 300          |
| Admix. #2:                   | Retarder - Chryso tard 100 |

Figure G.9. Texas concrete mixture design information.

Project: DFW Connector  
 Mix ID: SF - 1003  
 Sample Comments: Average of 2 Sieve Analyses from 6-09-2011  
 Test Date: 9-Jun-11

Total Cementitious Material: 451 lb/yd<sup>3</sup>  
 Agg. Ratios: 48.00% 14.00% 38.00% 100.00%

| Sieve  | Coarse | Intermediate #1 | Intermediate #2 | Fine #1 | Combined % Retained | Combined % Retained On Each Sieve | Combined % Passing |
|--------|--------|-----------------|-----------------|---------|---------------------|-----------------------------------|--------------------|
| 2 1/2" | 100%   | 100%            | na              | 100%    | 0%                  | 0%                                | 100%               |
| 2"     | 100%   | 100%            | na              | 100%    | 0%                  | 0%                                | 100%               |
| 1 1/2" | 100%   | 100%            | na              | 100%    | 0%                  | 0%                                | 100%               |
| 1"     | 84%    | 100%            | na              | 100%    | 8%                  | 8%                                | 92%                |
| 3/4"   | 60%    | 100%            | na              | 100%    | 19%                 | 12%                               | 81%                |
| 1/2"   | 28%    | 100%            | na              | 100%    | 35%                 | 16%                               | 65%                |
| 3/8"   | 17%    | 96%             | na              | 100%    | 40%                 | 6%                                | 60%                |
| #4     | 5%     | 33%             | na              | 99%     | 55%                 | 15%                               | 45%                |
| #8     | 2%     | 4%              | na              | 83%     | 67%                 | 12%                               | 33%                |
| #16    | 2%     | 3%              | na              | 66%     | 74%                 | 7%                                | 26%                |
| #30    | 2%     | 3%              | na              | 47%     | 81%                 | 7%                                | 19%                |
| #50    | 2%     | 2%              | na              | 16%     | 93%                 | 12%                               | 7%                 |
| #100   | 2%     | 2%              | na              | 2%      | 98%                 | 5%                                | 2%                 |
| #200   | 2.2%   | 3.8%            | na              | 1.8%    | 97.7%               | -0.3%                             | 2.3%               |

Workability Factor: 30.0  
 Coarseness Factor: 60.4

Note: na = not applicable.

Figure G.10. Texas sieve analysis test data (combined gradation).

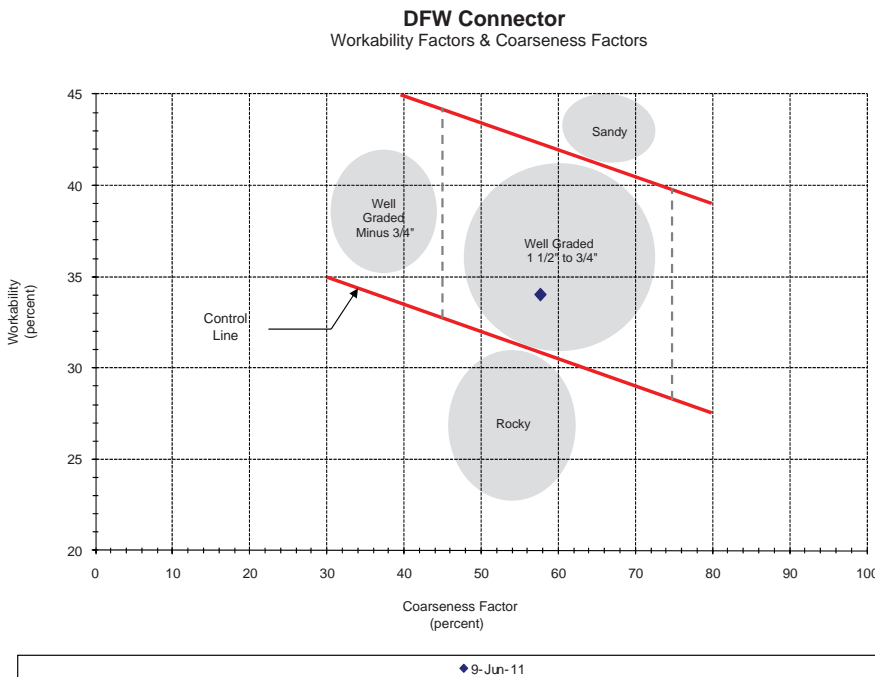
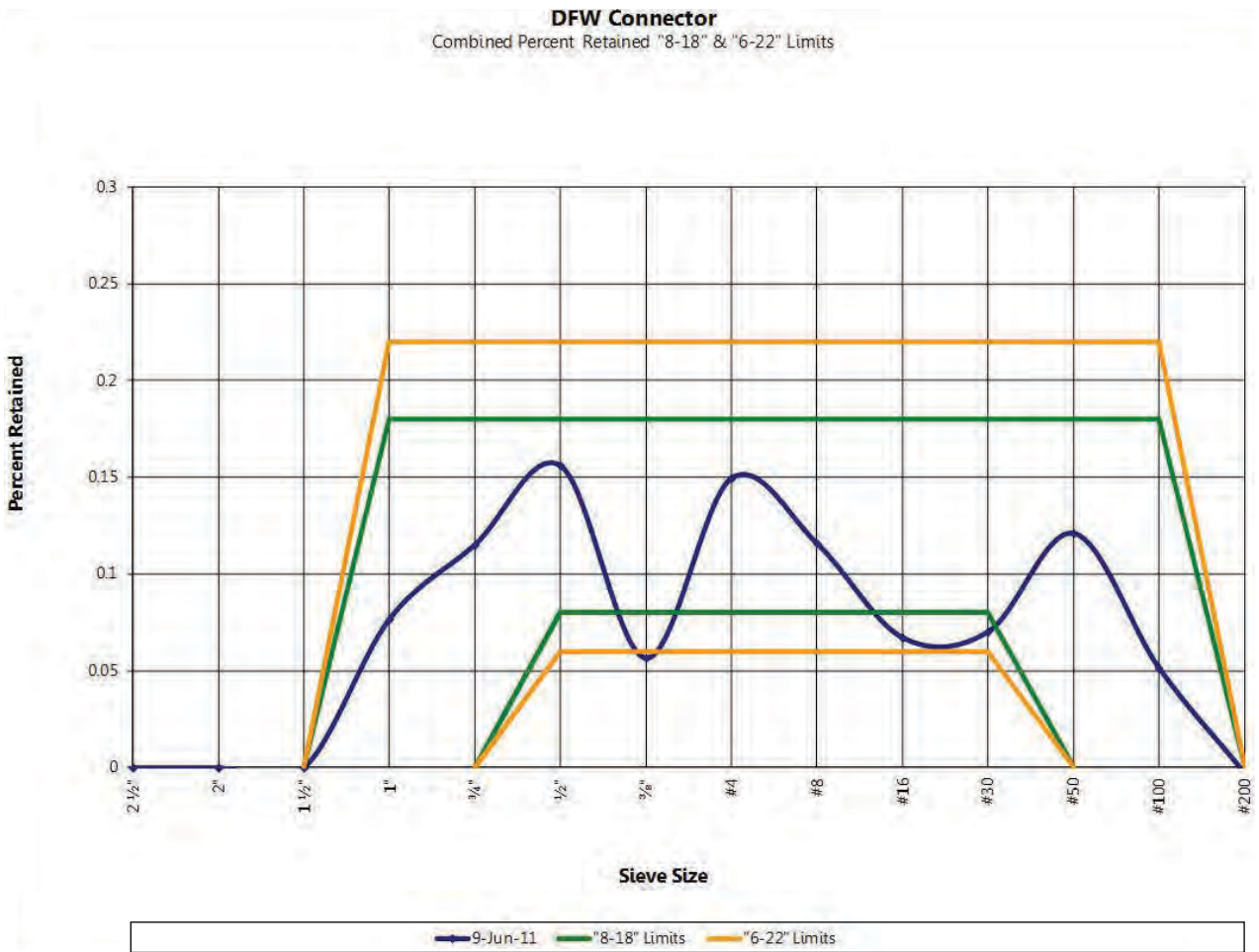


Figure G.11. Combined gradation coarseness and workability factors for Texas site.





**Figure G.12. Combined percent retained on individual sieves for Texas site.**

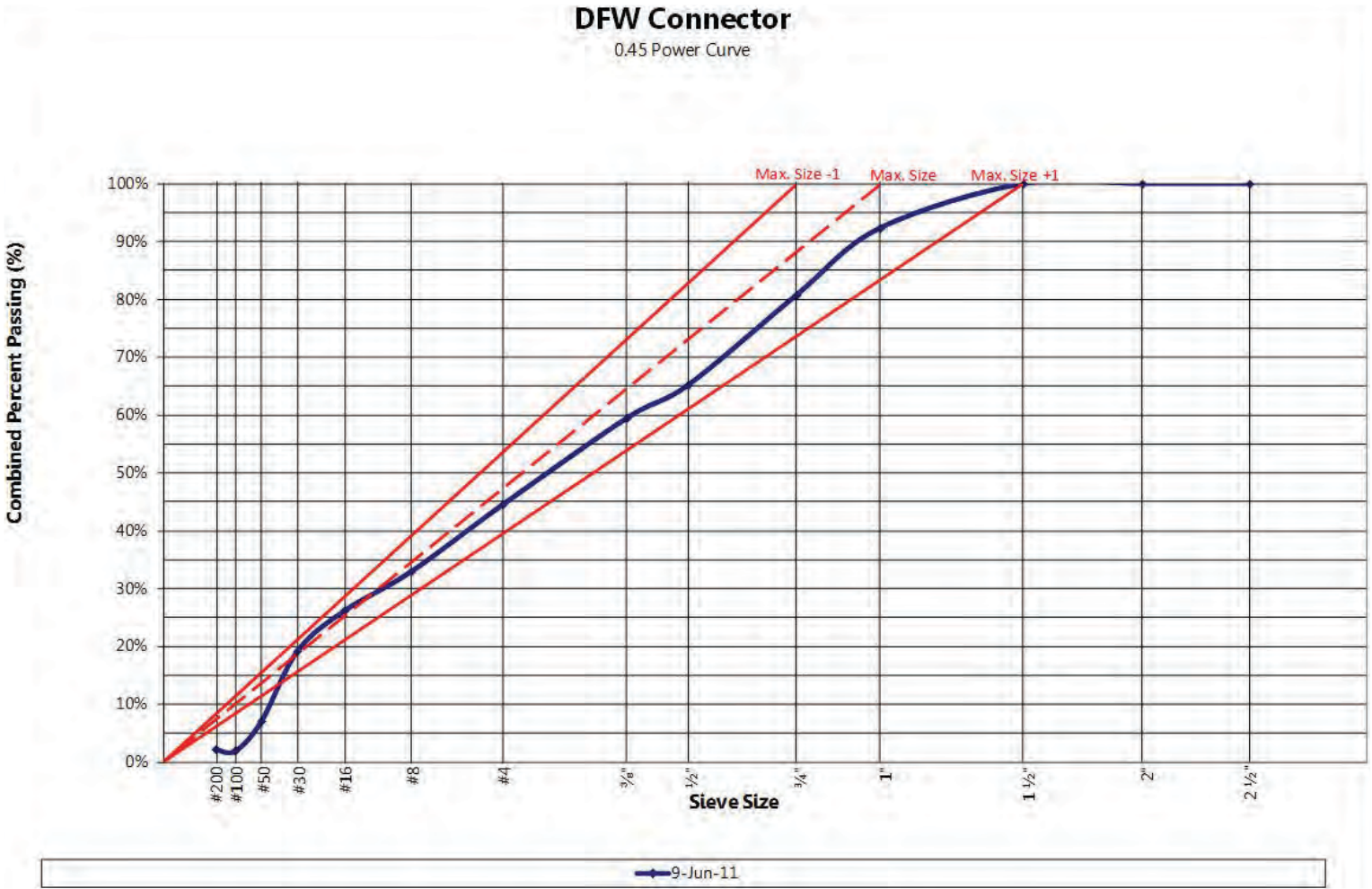


Figure G.13. Plot of the 0.45 power curve for Texas site.

| <b>Cementitious Materials</b> | Source         | Type | Spec. Gravity | lb/yd <sup>3</sup> | % Replacement by Mass |
|-------------------------------|----------------|------|---------------|--------------------|-----------------------|
| Portland Cement:              | Essroc         | I    | 3.150         | 375                |                       |
| GGBFS:                        |                |      |               |                    |                       |
| Fly Ash:                      | Fly Ash Direct | F    | 2.420         | 95                 | 20.21%                |
| Silica Fume:                  |                |      |               |                    |                       |
| Other Pozzolan:               |                |      |               |                    |                       |
|                               |                |      |               | 470                | lb/yd <sup>3</sup>    |
|                               |                |      |               | 5.0                | sacks/yd <sup>3</sup> |

| <b>Aggregate Information</b> | Source               | Type     | Spec. Gravity SSD | Absorption (%) |
|------------------------------|----------------------|----------|-------------------|----------------|
| Coarse Aggregate:            | Stoneco - Ottawa     | 6AAA - M | 2.718             | 1.80%          |
| Intermediate Aggregate:      | Stoneco - Moscow     | 26A      | 2.687             | 1.8%           |
| Fine Aggregate #1:           | Bailey Sand & Gravel | 2NS      | 2.651             | 1.90%          |
| Fine Aggregate #2:           |                      |          |                   |                |

|   |        |
|---|--------|
| Coarse Aggregate %:                     | 44.6%  |
| Intermediate Aggregate %:               | 14.0%  |
| Fine Aggregate #1 % of Total Fine Agg.: | 100.0% |
| Fine Aggregate #2 % of Total Fine Agg.: |        |
| Fine Aggregate #1 %:                    | 41.4%  |
| Fine Aggregate #2 %:                    |        |

| <b>Mix Proportion Calculations</b>  |       |
|-------------------------------------|-------|
| Water/Cementitious Materials Ratio: | 0.449 |
| Air Content:                        | 6.50% |

|                         | Volume (ft <sup>3</sup> )         | Batch Weights SSD (lb/yd <sup>3</sup> ) | Spec. Gravity | Absolute Volume (%) |
|-------------------------|-----------------------------------|---|---------------|---------------------|
| Portland Cement:        | 1.908                             | 375                                     | 3.150         | 7.07%               |
| GGBFS:                  |                                   |   |               |                     |
| Fly Ash:                | 0.629                             | 95                                      | 2.420         | 2.33%               |
| Silica Fume:            |                                   |   |               |                     |
| Other Pozzolan:         |                                   |   |               |                     |
| Coarse Aggregate:       | 8.619                             | 1,450                                   | 2.718         | 31.92%              |
| Intermediate Aggregate: | 2.706                             | 455                                     | 2.687         | 10.02%              |
| Fine Aggregate #1:      | 8.001                             | 1,345                                   | 2.651         | 29.63%              |
| Fine Aggregate #2:      |                                   |   |               |                     |
| Water:                  | 3.382                             | 211                                     | 1.000         | 12.53%              |
| Air:                    | 1.755                             |   |               | 6.50%               |
|                         | 27.000                            | 3,931                                   |               | 100.00%             |
|                         | Unit Weight (lb/ft <sup>3</sup> ) | 145.6                                   |               |                     |

| <b>Admixture Information</b> | Source/Description |
|------------------------------|--------------------|
| Air Entraining Admix.:       | BASF, AE-90        |
| Admix. #1:                   | BASF, Master Pave  |

Figure G.14. Michigan concrete mixture design information.

| <b>MI I-94 Real-Time Smoothness Technology Demonstration</b> |          |                  |             |                 |
|--|----------|------------------|-------------|-----------------|
| <b>Fresh Concrete Testing Summary</b>                        |          |                  |             |                 |
| Date   | Sample # | Conc. Temp. (°F) | Slump (in.) | Air Content (%) |
| 7/13/2011  | 1        | 72.0             | 1.0         | 7.4             |
| 7/13/2011  | 2        | 74.0             | 0.8         | 5.9             |
| 7/13/2011  | 3        | 76.0             | 0.8         | 5.9             |
| 7/14/2011  | 4        | 70.0             | 1.3         | 7.4             |
| 7/14/2011  | 5        | 72.0             | 1.0         | 5.9             |
| 7/14/2011  | 6        | 74.0             | 1.0         | 5.6             |
| 7/14/2011  | 7        | 74.0             | 0.8         | 5.3             |
| 7/14/2011  | 8        | 74.0             | 0.8         | 5.2             |
| Average of All Data  |          | 73.3             | 0.9         | 6.1             |

Note: Conc. = concrete.

Figure G.15. Summary of concrete test results for Michigan site.

Project: ARRA 0138(005)-105785A  
 Mix ID: 142-2  
 Sample Comments: Sieve Analysis Results from 12/JUL2011  
 Test Date: 12-Jul-11

Total Cementitious Material: 470 lb/yd<sup>3</sup>  
 Agg. Ratios: 44.60% 14.00% 41.40% 100.00%

| Sieve  | Coarse | Intermediate #1 | Intermediate #2 | Fine #1 | Combined % Retained | Combined % Retained On Each Sieve | Combined % Passing |
|--------|--------|-----------------|-----------------|---------|---------------------|-----------------------------------|--------------------|
| 2 1/2" | 100%   | 100%            | na              | 100%    | 0%                  | 0%                                | 100%               |
| 2"     | 100%   | 100%            | na              | 100%    | 0%                  | 0%                                | 100%               |
| 1 1/2" | 100%   | 100%            | na              | 100%    | 0%                  | 0%                                | 100%               |
| 1"     | 73%    | 100%            | na              | 100%    | 12%                 | 12%                               | 88%                |
| 3/4"   | 44%    | 100%            | na              | 100%    | 25%                 | 13%                               | 75%                |
| 1/2"   | 20%    | 98%             | na              | 100%    | 36%                 | 11%                               | 64%                |
| 3/8"   | 9%     | 77%             | na              | 100%    | 44%                 | 8%                                | 56%                |
| #4     | 4%     | 19%             | na              | 97%     | 55%                 | 12%                               | 45%                |
| #8     | 3%     | 3%              | na              | 85%     | 63%                 | 8%                                | 37%                |
| #16    | 2%     | 2%              | na              | 64%     | 72%                 | 9%                                | 28%                |
| #30    | 2%     | 2%              | na              | 37%     | 84%                 | 11%                               | 16%                |
| #50    | 2%     | 1%              | na              | 11%     | 94%                 | 11%                               | 6%                 |
| #100   | 2%     | 1%              | na              | 4%      | 97%                 | 3%                                | 3%                 |
| #200   | 1.4%   | 0.9%            | na              | 1.7%    | 98.5%               | 1.2%                              | 1.5%               |

Workability Factor: 34.4  
 Coarseness Factor: 69.5

Note: na = not applicable.

Figure G.16. Sieve analysis test data (combined gradation) for Michigan site.

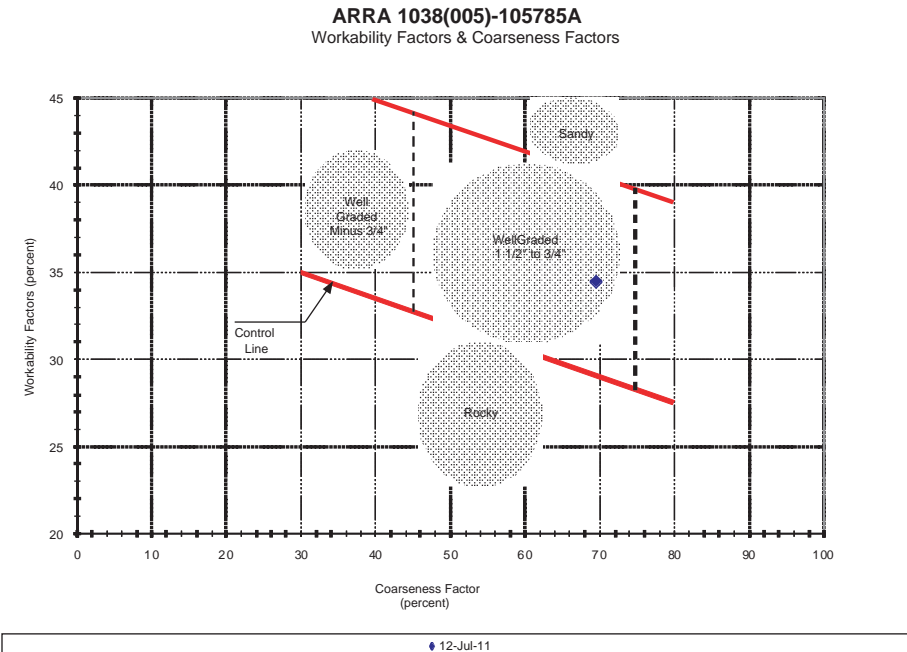
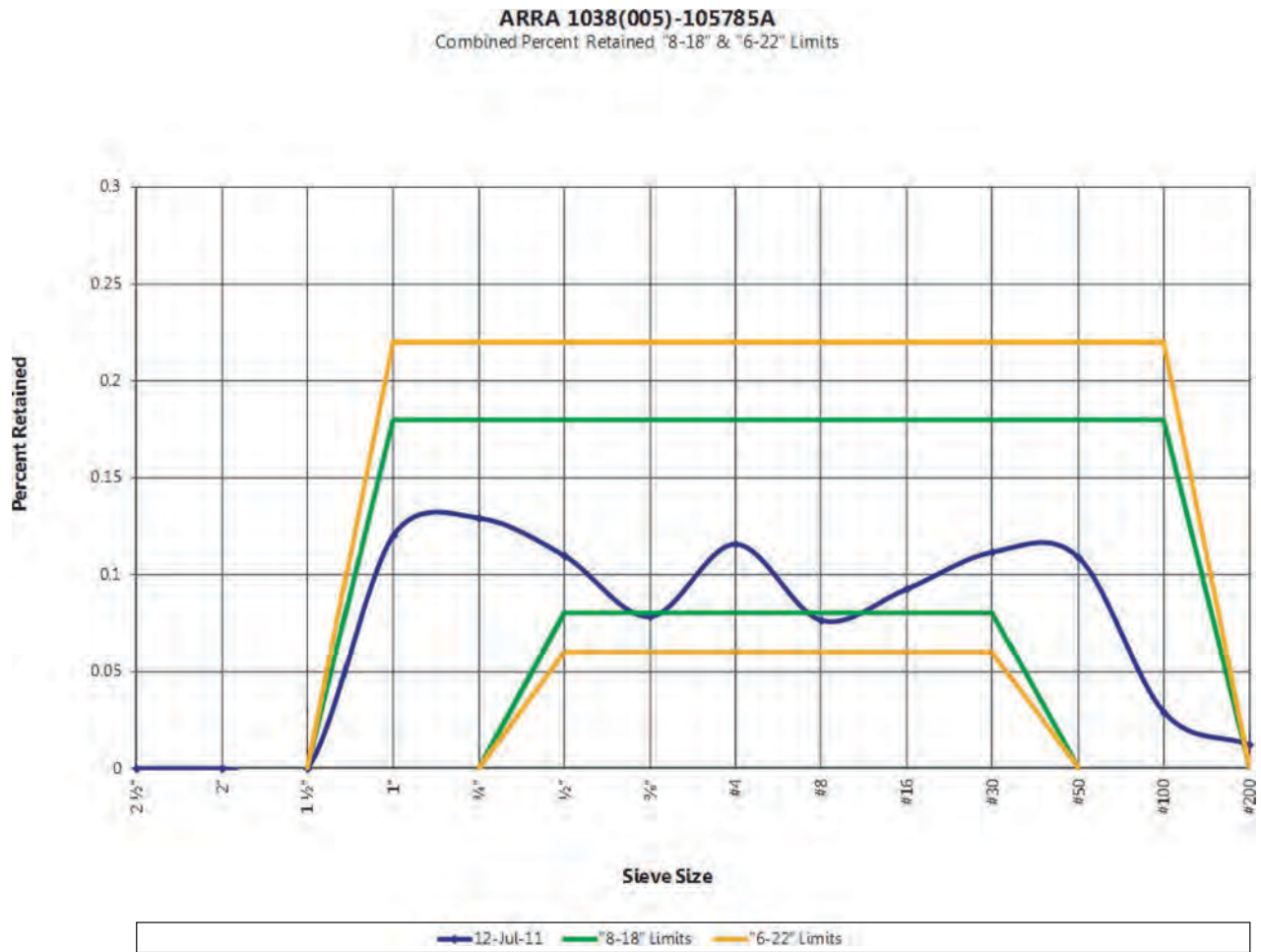


Figure G.17. Combined gradation coarseness and workability factors for Michigan site.





**Figure G.18. Combined percent retained on individual sieves for Michigan site.**

**ARRA 1038(005)-105785A**

0.45 Power Curve

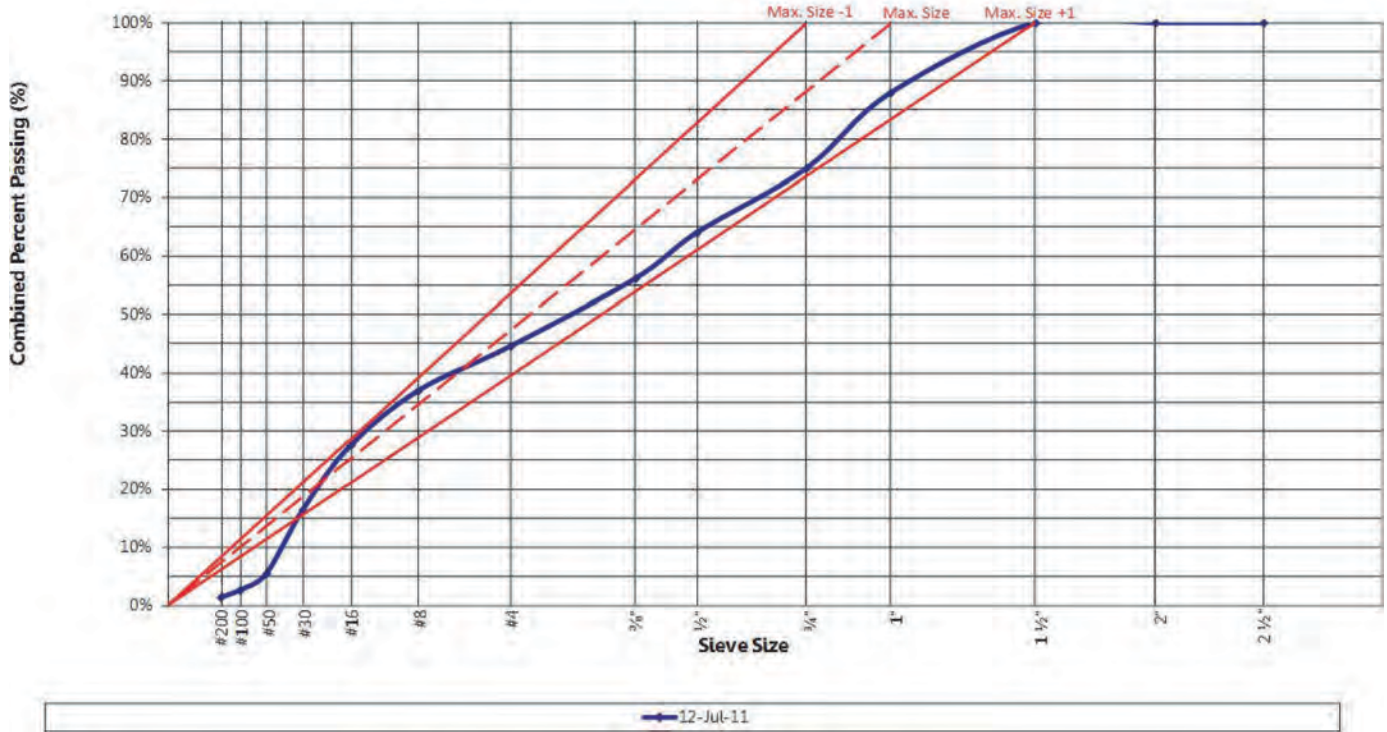


Figure G.19. Plot of the 0.45 power curve for Michigan site.

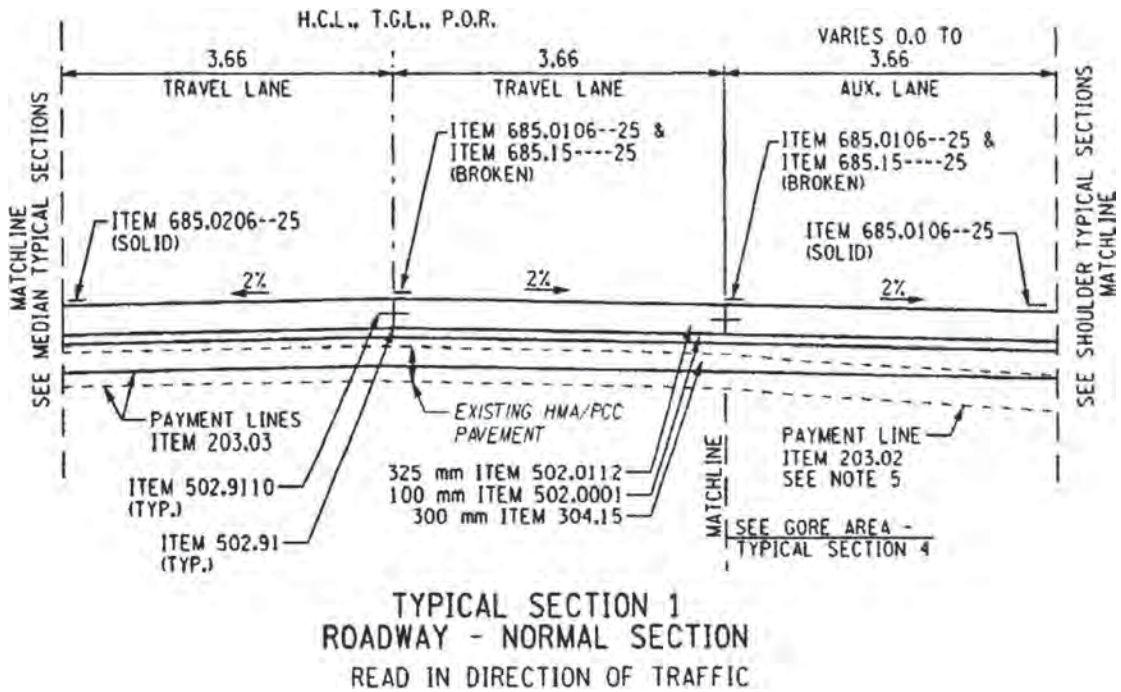


Figure G.20. Typical section for the Interchange 39-40 reconstruction.

| <b>Cementitious Materials</b> | Source     | Type | Spec. Gravity | lb/yd <sup>3</sup> | % Replacement by Mass |
|-------------------------------|------------|------|---------------|--------------------|-----------------------|
| Portland Cement:              | LaFarge    | II   | 3.150         | 458                |                       |
| GGBFS:                        |            |      |               |                    |                       |
| Fly Ash:                      | Headwaters | F    | 2.350         | 114                | 19.93%                |
| Silica Fume:                  |            |      |               |                    |                       |
| Other Pozzolan:               |            |      |               |                    |                       |
|                               |            |      |               | 572                | lb/yd <sup>3</sup>    |
|                               |            |      |               | 6.1                | sacks/yd <sup>3</sup> |

| <b>Aggregate Information</b> | Source          | Type       | Spec. Gravity SSD | Absorption (%) |
|------------------------------|-----------------|------------|-------------------|----------------|
| Coarse Aggregate:            | Hanson - Phelps | #57 4 - 8G | 2.680             |                |
| Intermediate Aggregate:      |                 |            |                   |                |
| Fine Aggregate #1:           | Hanson - Phelps | 4 - 8F     | 2.660             |                |
| Fine Aggregate #2:           |                 |            |                   |                |

|   |        |
|---|--------|
| Coarse Aggregate %:                     | 58.9%  |
| Intermediate Aggregate %:               |        |
| Fine Aggregate #1 % of Total Fine Agg.: | 100.0% |
| Fine Aggregate #2 % of Total Fine Agg.: |        |
| Fine Aggregate #1 %:                    | 41.1%  |
| Fine Aggregate #2 %:                    |        |

| <b>Mix Proportion Calculations</b>  |       |
|-------------------------------------|-------|
| Water/Cementitious Materials Ratio: | 0.439 |
| Air Content:                        | 6.50% |

|                         | Volume (ft <sup>3</sup> )         | Batch Weights SSD (lb/yd <sup>3</sup> ) | Spec. Gravity | Absolute Volume (%) |
|-------------------------|-----------------------------------|---|---------------|---------------------|
| Portland Cement:        | 2.330                             | 458                                     | 3.150         | 8.63%               |
| GGBFS:                  |                                   |   |               |                     |
| Fly Ash:                | 0.777                             | 114                                     | 2.350         | 2.88%               |
| Silica Fume:            |                                   |   |               |                     |
| Other Pozzolan:         |                                   |   |               |                     |
| Coarse Aggregate:       | 10.669                            | 1,800                                   | 2.680         | 39.51%              |
| Intermediate Aggregate: |                                   |   |               |                     |
| Fine Aggregate #1:      | 7.445                             | 1,255                                   | 2.660         | 27.57%              |
| Fine Aggregate #2:      |                                   |   |               |                     |
| Water:                  | 4.024                             | 251                                     | 1.000         | 14.90%              |
| Air:                    | 1.755                             |   |               | 6.50%               |
|                         | 27.000                            | 3,878                                   |               | 100.00%             |
|                         | Unit Weight (lb/ft <sup>3</sup> ) | 143.6                                   |               |                     |

| <b>Admixture Information</b> | Source/Description     |
|------------------------------|------------------------|
| Air Entraining Admix.:       | Terrapave, W.R. Grace  |
| Admix. #1:                   | Daracem 55, W.R. Grace |

**Figure G.21. New York concrete mixture design information.**

**NY I-90 Real-Time Smoothness Technology Demonstration  
Fresh Concrete Testing Summary**

| Date                | Sample # | Conc. Temp.<br>(°F) | Slump<br>(in.) | Air Content<br>(%) |
|---------------------|----------|---------------------|----------------|--------------------|
| 8/10/2011           | 1        | 72.0                | 2.0            | 7.2                |
| 8/10/2011           | 2        | 70.0                | 2.0            | 6.8                |
| 8/10/2011           | 3        | na                  | 2.0            | 6.6                |
| 8/10/2011           | 4        | na                  | 1.4            | 5.5                |
| 8/10/2011           | 5        | 72.0                | 1.6            | 6.6                |
| 8/10/2011           | 6        | 72.0                | 2.2            | 7.7                |
| 8/10/2011           | 7        | 71.0                | 1.6            | 7.6                |
| 8/10/2011           | 8        | 72.0                | 1.4            | 6.3                |
| 8/10/2011           | 9        | 74.0                | 1.4            | 5.9                |
| 8/10/2011           | 10       | 72.0                | 1.6            | 6.2                |
| 8/10/2011           | 11       | 74.0                | 1.4            | 6.8                |
| 8/10/2011           | 12       | 72.0                | 1.6            | 6.6                |
| 8/10/2011           | 13       | 74.0                | 1.8            | 6.5                |
| 8/10/2011           | 14       | 72.0                | 1.6            | 6.2                |
| 8/10/2011           | 15       | na                  | 1.4            | 5.2                |
| 8/10/2011           | 16       | 72.0                | 1.6            | 5.4                |
| 8/10/2011           | 17       | 75.0                | 2.0            | 7.4                |
| 8/10/2011           | 18       | na                  | 1.8            | 7.2                |
| 8/10/2011           | 19       | na                  | 1.6            | 6.8                |
| 8/10/2011           | 20       | na                  | 1.8            | 6.6                |
| 8/10/2011           | 21       | na                  | 1.4            | 6.5                |
| 8/10/2011           | 22       | 76.0                | 1.6            | 7.5                |
| 8/10/2011           | 23       | 76.0                | 1.2            | 8.0                |
| 8/10/2011           | 24       | 76.0                | 1.6            | 6.8                |
| 8/10/2011           | 25       | 76.0                | 0.8            | 5.8                |
| 8/10/2011           | 26       | 76.0                | 0.6            | 6.0                |
| 8/10/2011           | 27       | 77.0                | 1.4            | 6.2                |
| 8/10/2011           | 28       | 77.0                | 1.4            | 6.5                |
| 8/10/2011           | 29       | 77.0                | 1.0            | 5.4                |
| 8/10/2011           | 30       | 77.0                | 1.6            | 6.8                |
| 8/10/2011           | 31       | 78.0                | 1.2            | 6.2                |
| 8/10/2011           | 32       | 78.0                | 1.6            | 6.0                |
| 8/10/2011           | 33       | 78.0                | 1.8            | 6.2                |
| 8/10/2011           | 34       | 78.0                | 1.4            | 5.8                |
| Average of All Data |          | 74.6                | 1.5            | 6.5                |

Note: Conc. = concrete, na = not applicable.

**Figure G.22. Summary of concrete test results for New York site.**



Project: I-90 NY Thruway  
 Mix ID: Class C  
 Sample Comments: Sieve Analysis Results from 10AUG2011  
 Test Date: 10-Aug-11

Total Cementitious Material: 572 lb/yd<sup>3</sup>  
 Agg. Ratios: 58.90% 41.10% 100.00%

| Sieve  | Coarse | Intermediate #1 | Intermediate #2 | Fine #1 | Combined % Retained | Combined % Retained On Each Sieve | Combined % Passing |
|--------|--------|-----------------|-----------------|---------|---------------------|-----------------------------------|--------------------|
| 2 1/2" | 100%   | na              | na              | 100%    | 0%                  | 0%                                | 100%               |
| 2"     | 100%   | na              | na              | 100%    | 0%                  | 0%                                | 100%               |
| 1 1/2" | 100%   | na              | na              | 100%    | 0%                  | 0%                                | 100%               |
| 1"     | 96%    | na              | na              | 100%    | 2%                  | 2%                                | 98%                |
| 3/4"   | 73%    | na              | na              | 100%    | 16%                 | 14%                               | 84%                |
| 1/2"   | 49%    | na              | na              | 100%    | 30%                 | 14%                               | 70%                |
| 3/8"   | 28%    | na              | na              | 100%    | 42%                 | 12%                               | 58%                |
| #4     | 4%     | na              | na              | 100%    | 57%                 | 14%                               | 43%                |
| #8     | 2%     | na              | na              | 90%     | 62%                 | 5%                                | 38%                |
| #16    | 2%     | na              | na              | 63%     | 73%                 | 11%                               | 27%                |
| #30    | 2%     | na              | na              | 35%     | 84%                 | 12%                               | 16%                |
| #50    | 2%     | na              | na              | 18%     | 91%                 | 7%                                | 9%                 |
| #100   | 2%     | na              | na              | 8%      | 96%                 | 4%                                | 4%                 |
| #200   | 1.0%   | na              | na              | 1.0%    | 99.0%               | 3.5%                              | 1.0%               |

Workability Factor: 38.4  
 Coarseness Factor: 68.6

Note: na = not applicable.

Figure G.23. Sieve analysis test data (combined gradation) for New York.

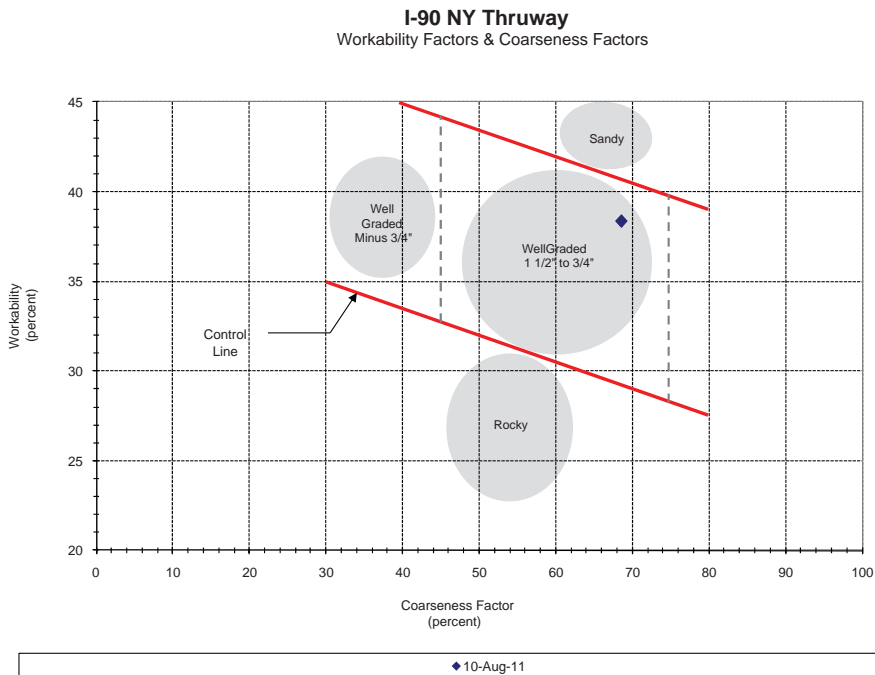


Figure G.24. Combined gradation coarseness and workability factors for New York site.

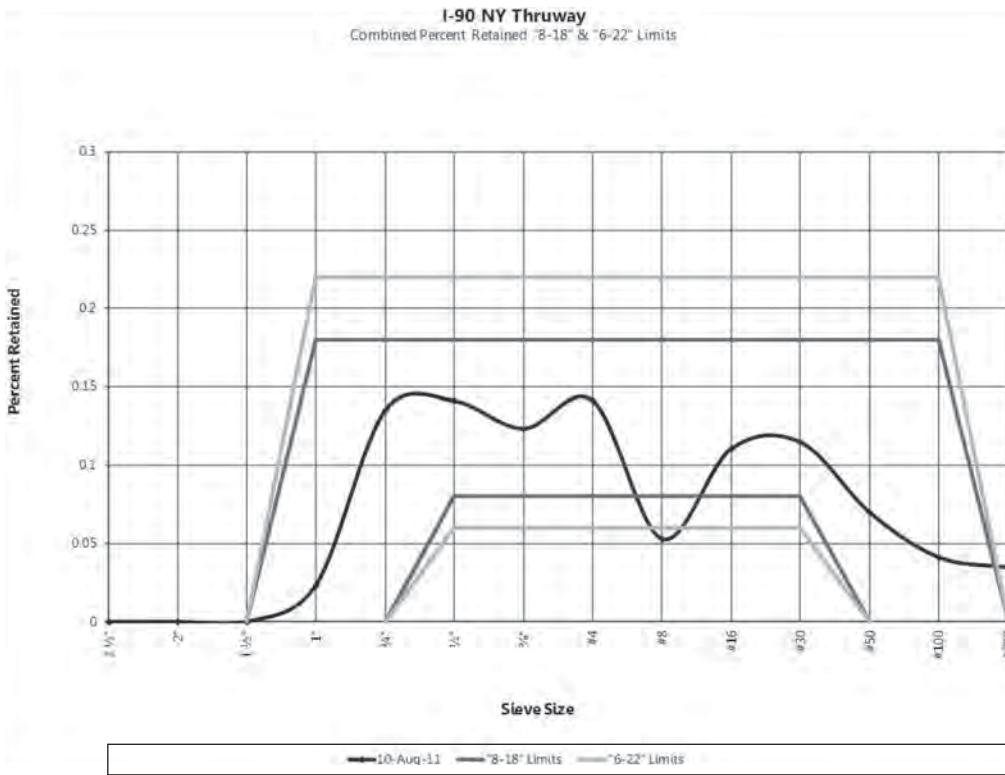


Figure G.25. Combined percent retained on individual sieves for New York site.



## A P P E N D I X H

---

### Recommended Practice for

# Real-Time Smoothness Measurements on Concrete Pavements During Construction

XX-## (2012)

---

## 1. SCOPE

- 1.1. This document provides language that can be used by an Owner-Agency to develop equipment and construction specifications with the objective of conducting real-time smoothness measurements on concrete pavements during construction. These measurements involve conducting pavement profile measurements as pavement is being constructed in order to provide smoothness-related feedback and the corresponding displays to the paving crew. This information is intended for quality control and process improvement purposes and not as a replacement for quality acceptance tests. Nevertheless, the practices presented herein have been demonstrated to increase the likelihood of constructing durable, smoother concrete pavements.
- 1.2. If any part of this practice is in conflict with references made, such as ASTM or AASHTO Standards, this practice takes precedence for its purposes.
- 1.3. The values stated are in U.S. Customary units and are to be regarded as the standard.
- 1.4. This practice should only be adopted after an evaluation of existing smoothness measurement standards. Smoothness standards should be modified as necessary to minimize or eliminate prescriptive language that may conflict with the end-result practices described herein.
- 1.5. *This specification does not purport to address all of the safety concerns, if any, associated with its use. It is the responsibility of the user of this specification to establish appropriate safety and health practices and determine the applicability of regulatory limitations related to and prior to its use.*

## 2. REFERENCED DOCUMENTS

### 2.1. AASHTO Standards:

- M 328-10 Standard Specification for Inertial Profiler
- R 54-10 Standard Practice for Accepting Pavement Ride Quality When Measured Using Inertial Profiling Systems

- R 56-10 Standard Practice for Certification of Inertial Profiling Systems
- R 57-10 Standard Practice for Operating Inertial Profiling System

## 2.2. ASTM Standards:

- E 1926, Standard Practice for Computing International Roughness Index of Roads from Longitudinal Profile Measurements

## 2.3. Other

- Kansas DOT Standard Specifications for State Road and Bridge Construction: Section 503, Portland Cement Concrete Pavement Smoothness
- Texas DOT Test Procedures (1000-S Series): Tex-10010S, Operating Inertial Profilers and Evaluating Pavement Profiles

## 3. TERMINOLOGY

- 3.1. *International roughness index (IRI)*—according to AASHTO R 56-10, a statistic used to determine the amount of roughness in a measured longitudinal profile. The IRI is computed from a single longitudinal profile using a quarter-car simulation as described in the paper “On the Calculation of International Roughness Index from Longitudinal Road Profile” (Sayers 1995). Computer programs to calculate the IRI statistic from a longitudinal profile are referenced in ASTM E 1926.
- 3.2. *Localized roughness*—according to AASHTO R 54-10, short sections of roadway that contribute disproportionately to the overall roughness index value. Areas of localized roughness are identified using a report of continuous IRI with a base length of 25 ft. This yields the IRI of every possible 25-ft segment. Any segment for which the continuous report exceeds a threshold IRI value is considered a defective segment requiring correction.
- 3.3. *Profile*—according to AASHTO M 328-10, [this] is a two-dimensional slice of the roadway surface, taken along an imaginary line, such as the wheelpath, in the longitudinal or travel direction. It represents the perpendicular deviations of the pavement surface from an established reference parallel to the horizontal.
- 3.4. *Profilograph index (PrI)*—a smoothness index that is computed from a profilograph trace. This is sometimes called profile index (PI), but is more specifically called PrI.
- 3.5. *Real-time smoothness*—conducting pavement profile measurements as pavement is being constructed.
- 3.6. *Roughness profile*—a plot that shows the variation of roughness (i.e., IRI, PrI) over a section of pavement.
- 3.7. *Smoothness statistic*—a statistic that summarizes the roughness qualities of a section of pavement, such as the IRI or PrI.

## 4. SIGNIFICANCE AND USE

- 4.1. This example provides specification language for conducting real-time smoothness measurements in concrete pavements during construction. Smoothness statistics for profiles measured in real time differ from the smoothness statistics for profiles measured on the final surface due to subsequent effect such as those caused by texturing, joint sawing, curling, warping, etc.

## 5. EQUIPMENT

- 5.1. *General Requirements*—Provide a qualified real-time smoothness measuring system. Provide the Owner-Agency with documentation of the system’s qualifications.



- 5.1.1. *Profiler*—The profiler shall be equipped with various sensors, interface hardware, computer hardware, and software that, working together, perform the measurement and recording of the longitudinal profile. The profile of the traveled trace(s) is the combination of a processed elevation and the distance traveled. The data shall be stored internally during the test and transferable onto suitable high-density removable storage media after the test.
    - 5.1.1.1. The profiler shall have the capability to process the collected data, to display the derived profile(s), and to report industry standard indices including IRI and simulated profilograph index.
    - 5.1.1.2. The profiler shall function independently from motion and vibration of the hardware to which it is mounted.
  - 5.1.2. *Mounting*—The equipment shall mount on the paving machine behind the pan or on an independent work bridge with minimum disturbance to the paving operation and without contacting the fresh pavement surface.
  - 5.1.3. *Data Display*—The system shall include a live readout display accessible by the project supervisor or the paver operator. Such display needs to be visible in daylight.
  - 5.1.4. *Software*—The system operational software shall provide a means to trigger the start of data collection manually at a given location and terminate data collection manually at a given location.
  - 5.1.5. *Calibration*—The equipment shall have built-in provisions to facilitate the calibration of each transducer signal. Any external devices required for calibration shall be included with the equipment. In addition, it shall have an alarm system that alerts the operator if signals are out of range, or fail to vary. These systems, in conjunction with a calibration protocol specified by the supplier, shall ensure the accuracy of the data.
- 5.2. *Functional Capabilities*—The system shall meet the following specifications:
- 5.2.1. The system shall measure distance data in feet, meters, kilometers, or miles in an incrementing or decrementing mode from a selected starting point and relate the distance to station at any point.
  - 5.2.2. The system shall be capable of obtaining and storing profile measurement data at a longitudinal distance interval of 3 inches or less.
  - 5.2.3. The system shall be capable of calculating, displaying, and storing the average roughness value obtained from the stored data at user-specified intervals. The system shall be capable of collecting and storing internally at least 25 lane miles of profile data.
  - 5.2.4. A vehicle-mounted distance transducer shall be provided to produce a pulse for units of distance traveled by the paver along the track line. The data acquisition system (DAS) shall accept these pulses and in combination with the DAS software shall determine distance traveled and vehicle speed. The system shall process the signals and record the data from the unit. The calibration procedure shall establish and record the data to allow the recorded distance pulses to be interpreted into the desired measurement units selected by the operator. The measured distance shall be accurate to 0.1 percent per mile for typical test speeds.
  - 5.2.5. The DAS shall be capable of recording profile in at least four tracks simultaneously.
  - 5.2.6. The system shall demonstrate agreement with a reference profile via cross-correlation on smooth-textured hardened concrete of 0.8 or better, with 0.94 preferred.
- 5.3. *Software*—The profiler shall be capable of producing profile files in the format described by ASTM E 2560.
- 5.3.1. The system shall provide a plot of elevation versus distance in real time.
  - 5.3.2. The roughness of each profile trace shall be produced in real time using any user-selected report interval chosen for the calculation.
  - 5.3.3. The system shall be capable of calculating a continuous IRI or PrI with a relatively short running interval (25 to 528 ft) and reporting the value and location of continuous IRI values above a user-settable threshold.

- 5.3.4. The system shall be capable of warning the user at localized rough spots, either determined by a high short-interval IRI value, or failure of a simulated profilograph bump template.
- 5.3.5. The system shall permit the user to record event markers and reset the station value in real time at a known landmark.

## 6. EQUIPMENT VERIFICATION

- 6.1. *Accuracy and Repeatability*—As outlined in Section 5.2.6, the system shall demonstrate agreement with a reference profile via cross-correlation on smooth-textured hardened concrete of 0.8 or better, with 0.94 preferred. The following steps are recommended to accomplish equipment verification, as often as required by the Owner-Agency:
  - 6.1.1. A 1,000-ft-long section should be established at the beginning of the project to conduct profile measurements as soon as the pavement is strong enough to support light traffic. Before testing, the concrete surface should be thoroughly cleaned using a motorized broom or other means approved by the Owner-Agency.
  - 6.1.2. *Repeatability*—Conduct a set of three repeat profile measurements along the track of interest (i.e., wheelpath or center of the lane), with the real-time profiler mounted to a stable host vehicle. The equipment manufacturer is to provide detailed specifications to complete this exercise.
    - 6.1.2.1. Evaluate repeatability by conducting cross-correlation analysis of the repeat measurements using ProVAL (or the technology-associated software). This analysis procedure is thoroughly described in AASHTO R 56-10: Standard Practice for Certification of Inertial Profiling Systems.
  - 6.1.3. *Accuracy*—Conduct a set of three repeat profile measurements with a reference profiler, such as a Dipstick® or Walking Profiler.
    - 6.1.3.1. Evaluate accuracy by conducting cross-correlation analysis of the profile measurements with the real-time profiler and the reference profiler using ProVAL (or the technology-associated software). As previously mentioned, this analysis procedure is thoroughly described in AASHTO R 56-10.

## 7. WORK METHODS

- 7.1. *Pre-paving Activities*—Inspect the paver track line for roughness before paving begins and mark any deviations in order to monitor their impact on the real-time smoothness measurements. Mark “leave-out” sections as well, as these may also have an impact on the real-time smoothness measurements.
  - 7.1.1. Determine the location of the longitudinal traces to be profiled based on the project specifics and how many sensors the system includes.
    - 7.1.1.1. Typical profile lines include wheelpaths or the center of the lane, and it is recommended to take in consideration the location for the measurements on the final hardened concrete.
    - 7.1.1.2. If the system configuration allows and according to the paving project specifics, profile measurements may be taken along the same line at different points in the paving train. For example, a possible application is to conduct measurements behind the paver followed by measurements behind the hand-finishing operation in order to assess its effects on smoothness.
- 7.2. *Testing*—Perform continuous real-time profile measurements on a daily basis, throughout the duration of the project.
  - 7.2.1. Operate the real-time smoothness measuring system in accordance with the manufacturer specifications in order to provide real-time feedback to the project supervisor or the paver operator throughout the day.
    - 7.2.1.1. Use the event marker tool to record relevant events (i.e., track line roughness, leave-outs, etc.) that are expected to have an impact on smoothness.

- 7.2.2. Use the technology-associated software to monitor the profile elevations and roughness profile (continuous IRI/PrI plot) in real time.
- 7.2.2.1. If an average IRI or PrI is observed, set a threshold using the technology-associated software that, if exceeded, the software will alert of potential localized roughness.
- 7.2.3. Provide the project supervisor or project engineer the test data in the native/proprietary file format and in a file format readable by ProVAL (e.g., ERD), as requested throughout the day.
- 7.2.3.1. Provide a clear description, identifying the lanes, profile trace, and location of the sensors with respect to the paving train.

**Note 1**—The Profile Viewer and Analysis (ProVAL) software program, originally developed for the Federal Highway Administration, can be used to import, display, and analyze the characteristics of pavement profiles from many different sources and is available for free at [www.RoadProfile.com](http://www.RoadProfile.com).

- 7.3. *Detailed Analysis*—The project supervisor or project engineer will use the technology-associated software or ProVAL to conduct detailed analysis of the profiles measured in real time, as required throughout the day. Such analysis is site specific and depends on what issues are encountered at each site (e.g., equipment tracking, stringline breaks/sags, concrete delivery, frequent paver stops, etc.).

When using ProVAL the following visualization and analysis techniques should be used:

1. ProVAL Viewer—This feature allows the user to plot elevation versus distance. Quite often, diagnostics can be made in this way, particularly if multiple profiles are being compared. The user should look for trends in the profile, along with rapid changes in elevation. To make the most use of this feature, profiles should be filtered using a high-pass Butterworth filter with a cutoff frequency of 100 to 300 ft.
2. Profilograph Simulation Analysis—While many states have made advancements toward using the IRI as a quality metric, some continue to use profilograph indices. ProVAL can be used to analyze the real-time (and other) profiles in such a way to simulate the results of a profilograph. In this way, the “traces” from the various profilers can be compared. Localized roughness can be identified via scallops on these traces, and the overall profilograph indices calculated based on various blanking bands (commonly used values include 0.0 and 0.2 in.).
3. Continuous Ride Quality (IRI) Analysis—This analysis is more relevant to ride quality (as compared to the profilograph analysis). ProVAL can be used to process the profiles in such a way to provide a continuous “trace” of IRI. With this, roughness in the vicinity of any given location can be quantified in a relevant manner. During this analysis, various “Segment Lengths” can be used, but often those in the range of 100 to 500 ft will yield helpful results. Too small a length will make a visual interpretation of the results more difficult, and too long a length will make the identification of localized roughness more difficult.
4. Power Spectral Density (PSD) Analysis—This more advanced analysis can be particularly useful in understanding ongoing “systematic” elements of the profile. Many of the construction artifacts discussed in this report are ones that occur on a repeated basis throughout the paving process. The PSD analysis allows these artifacts to be efficiently identified. Furthermore, when comparing the PSD traces from different profilers or profiler positions, further interpretation can be made about the source of the repeating feature.
5. Cross-Correlation Analysis—This technique can yield a couple of important benefits when analyzing real-time profiler data. First, it can be used to synchronize profiles collected by various equipment. Second, the “similarity” between profiles can be quantified using this technique through the reporting of a “correlation coefficient.” As this value approaches zero, there is less and less similarity between the profiles being compared. As the value approaches 1, the profiles are deemed similar, and the higher the number, the more similar they are. Specific thresholds for comparing profiles can be found elsewhere (most notably the *Critical Profiler Accuracy Report*, prepared by Karamihas in 2005).

The specifics about how these analyses can be performed in ProVAL are not included here, since they can instead be found in the supporting documentation for the ProVAL software.

- 7.3.1. The project supervisor or the paver operator will use the results of the detailed analysis to evaluate the paving methods and equipment. If the source of localized roughness or objectionable profile characteristics is identified during the analysis, adjustments may be made.

## 8. MEASUREMENT AND PAYMENT

- 8.1. *Measurement and Payment*—The work performed, materials furnished, equipment, labor, tools, and incidentals will not be measured or paid for directly, but will be subsidiary to bid items of the contract. No incentive or disincentives are associated with real-time smoothness measurements.

## 9. REFERENCES

- 9.1 Sayers, M. W. 1995. On the Calculation of International Roughness Index from Longitudinal Road Profile. In *Transportation Research Record: Journal of the Transportation Research Board, No. 1501*, TRB, National Research Council, Washington, D.C., pp. 1–12.
- 9.2 Karamihas, S. M. 2005. *Critical Profiler Accuracy Requirements*. Report UMTRI 2005-24. The University of Michigan Transportation Research Institute, Ann Arbor.



## **TRB OVERSIGHT COMMITTEE FOR THE STRATEGIC HIGHWAY RESEARCH PROGRAM 2\***

CHAIR: **Kirk T. Steudle**, *Director, Michigan Department of Transportation*

### **MEMBERS**

**H. Norman Abramson**, *Executive Vice President (retired), Southwest Research Institute*  
**Alan C. Clark**, *MPO Director, Houston–Galveston Area Council*  
**Frank L. Danchetz**, *Vice President, ARCADIS-US, Inc.*  
**Stanley Gee**, *Executive Deputy Commissioner, New York State Department of Transportation*  
**Michael P. Lewis**, *Director, Rhode Island Department of Transportation*  
**Susan Martinovich**, *Director, Nevada Department of Transportation*  
**John R. Njord**, *Executive Director, Utah Department of Transportation*  
**Charles F. Potts**, *Chief Executive Officer, Heritage Construction and Materials*  
**Ananth K. Prasad**, *Secretary, Florida Department of Transportation*  
**Gerald M. Ross**, *Chief Engineer, Georgia Department of Transportation*  
**George E. Schoener**, *Executive Director, I-95 Corridor Coalition*  
**Kumares C. Sinha**, *Olson Distinguished Professor of Civil Engineering, Purdue University*  
**Paul Trombino III**, *Director, Iowa Department of Transportation*

### **EX OFFICIO MEMBERS**

**John C. Horsley**, *Executive Director, American Association of State Highway and Transportation Officials*  
**Victor M. Mendez**, *Administrator, Federal Highway Administration*  
**David L. Strickland**, *Administrator, National Highway Transportation Safety Administration*

### **LIAISONS**

**Ken Jacoby**, *Communications and Outreach Team Director, Office of Corporate Research, Technology, and Innovation Management, Federal Highway Administration*  
**Tony Kane**, *Director, Engineering and Technical Services, American Association of State Highway and Transportation Officials*  
**Jeffrey F. Paniati**, *Executive Director, Federal Highway Administration*  
**John Pearson**, *Program Director, Council of Deputy Ministers Responsible for Transportation and Highway Safety, Canada*  
**Michael F. Trentacoste**, *Associate Administrator, Research, Development, and Technology, Federal Highway Administration*

## **RENEWAL TECHNICAL COORDINATING COMMITTEE\***

CHAIR: **Cathy Nelson**, *Technical Services Manager/Chief Engineer, Oregon Department of Transportation*

### **MEMBERS**

**Rachel Arulraj**, *Director of Virtual Design & Construction, Parsons Brinckerhoff*  
**Michael E. Ayers**, *Consultant, Technology Services, American Concrete Pavement Association*  
**Thomas E. Baker**, *State Materials Engineer, Washington State Department of Transportation*  
**John E. Breen**, *Al-Rashid Chair in Civil Engineering Emeritus, University of Texas at Austin*  
**Daniel D'Angelo**, *Recovery Acting Manager, Director and Deputy Chief Engineer, Office of Design, New York State Department of Transportation*  
**Steven D. DeWitt**, *Chief Engineer, North Carolina Turnpike Authority*  
**Tom W. Donovan**, *Senior Right of Way Agent (retired), California Department of Transportation*  
**Alan D. Fisher**, *Manager, Construction Structures Group, Cianbro Corporation*  
**Michael Hemmingsen**, *Davison Transportation Service Center Manager (retired), Michigan Department of Transportation*  
**Bruce Johnson**, *State Bridge Engineer, Oregon Department of Transportation, Bridge Engineering Section*  
**Leonnie Kavanagh**, *PhD Candidate, Seasonal Lecturer, Civil Engineering Department, University of Manitoba*  
**John J. Robinson, Jr.**, *Assistant Chief Counsel, Pennsylvania Department of Transportation, Governor's Office of General Counsel*  
**Michael Ryan**, *Vice President, Michael Baker Jr., Inc.*  
**Ted M. Scott II**, *Director, Engineering, American Trucking Associations, Inc.*  
**Gary D. Taylor**, *Professional Engineer*  
**Gary C. Whited**, *Program Manager, Construction and Materials Support Center, University of Wisconsin–Madison*

### **AASHTO LIAISON**

**James T. McDonnell**, *Program Director for Engineering, American Association of State Highway and Transportation Officials*

### **FHWA LIAISONS**

**Steve Gaj**, *Leader, System Management and Monitoring Team, Office of Asset Management, Federal Highway Administration*  
**Cheryl Allen Richter**, *Assistant Director, Pavement Research and Development, Office of Infrastructure Research and Development, Federal Highway Administration*  
**J. B. "Butch" Wlaschin**, *Director, Office of Asset Management, Federal Highway Administration*

### **CANADA LIAISON**

**Lance Vigfusson**, *Assistant Deputy Minister of Engineering & Operations, Manitoba Infrastructure and Transportation*

---

\*Membership as of August 2012.

## Related SHRP 2 Research

Technologies to Support Storage, Retrieval, and Utilization of 3-D Utility Location Data (R01A)

Precast Concrete Pavement Technology (R05)

A Plan for Developing High Speed, Nondestructive Testing Procedures for both Design Evaluation and Construction Inspection (R06)

Evaluating Applications of Field Spectroscopy Devices to Fingerprint Commonly Used Construction Materials (R06B)

Composite Pavement Systems (R21)