



## TR News May-June 2013: Railroads and Research: Sharing Track

### DETAILS

---

68 pages | 8.5 x 11 | PAPERBACK

ISBN 978-0-309-43417-1 | DOI 10.17226/22530

### AUTHORS

---

Transportation Research Board

BUY THIS BOOK

FIND RELATED TITLES

### Visit the National Academies Press at [NAP.edu](http://NAP.edu) and login or register to get:

---

- Access to free PDF downloads of thousands of scientific reports
- 10% off the price of print titles
- Email or social media notifications of new titles related to your interests
- Special offers and discounts



Distribution, posting, or copying of this PDF is strictly prohibited without written permission of the National Academies Press. (Request Permission) Unless otherwise indicated, all materials in this PDF are copyrighted by the National Academy of Sciences.

# TR NEWS

NUMBER 286

MAY–JUNE 2013

## RAILROADS AND RESEARCH: SHARING TRACK

### 3 INTRODUCTION

#### **Railroads and Research Sharing Track**

*John Tunna and Deborah Butler*

The railroad industry successfully provides safe and efficient freight and passenger transportation largely by implementing research results. Examples highlighted in this issue are drawn from the disciplines of civil, mechanical, and electrical engineering and from the science of human factors.

### 4 **Crash Energy Management: An Overview of Federal Railroad Administration Research**

*David Tyrell and Jeff Gordon*

From 1999 to 2005, the Federal Railroad Administration, working with industry stakeholders, conducted a series of six impact tests to assess the crashworthiness of rail passenger equipment, both conventional and with crash energy management features. The results can improve train crashworthiness significantly.

#### **11 Realizing the Potential of Diesel Multiple-Unit Technology: Research Overcomes Barriers**

*Thomas C. Cornillie*

### 12 **Cooperative Research in Tank Car Safety Design: How Science and Engineering Are Reducing the Risk of Rail Transport of Hazardous Materials**

*Christopher P. L. Barkan, M. Rapik Saat, Francisco González, III, and Todd T. Treichel*

Railroad tank car safety in North America has improved continuously through cooperative testing, research, and standards development by industry and government. Recent design advances have followed three approaches to enhance the safety of tank cars, which transport more than 1.6 million shipments of hazardous materials each year: statistical analysis and optimization of design, structural modeling, and physical testing.

#### **20 Transporting Hazardous Materials by Rail: Identifying Feasible, Lower-Risk Routes**

*David Hunt, David Friedman, Mark Meketon, and Carl Van Dyke*

### 22 **Gaining Track Support to Improve Track Safety, Efficiency, and the Competitiveness of the Rail Industry**

*Ted Sussmann, David Read, John Choros, and Shane M. Farritor*

Track components have been hardened and strengthened to improve durability and performance, but increases in train loads and speeds, coupled with recent extreme weather events, have necessitated constant vigilance for track safety. The authors explore advances in track support and measurement systems that are ensuring a more efficient and safe performance from the track structure.

### 28 **Evaluations of Demonstration Pilots Produce Change: Fourteen Years of Safety-Culture Improvement Efforts by the Federal Railroad Administration**

*Joyce M. Ranney, Michael K. Zuschlag, Jonathan Morell, Michael K. Coplen, Jordan Multer, and Thomas G. Raslear*

To address the slow progress in reducing accidents, the Federal Railroad Administration implemented an evaluation program to identify and test system-based safety-culture interventions. The program produced four approaches and confirmed significant positive results, particularly through change effected collaboratively by labor and management.

#### **37 Fatigue Research Improves Regulatory Effectiveness**

*Thomas G. Raslear and Colleen A. Brennan*

### 38 **Success Factors in the Reduction of Highway–Rail Grade Crossing Incidents**

*Suzanne M. Horton and Marco P. daSilva*

In the past 20 years, safety at public highway–rail grade crossings has improved significantly. A two-phase study identified 11 factors as likely contributors, including rulemakings, advances in the grade crossing and transportation environment, and political, societal, and economic changes. Most of the 11 factors were associated with applications of research findings.



4



22



28



COVER: Known as the Warm Springs local, a BNSF train leaves the Port of Oakland, California, through the Jack London Square neighborhood; the train provides competitive access to Silicon Valley shippers. (Photo: Thomas C. Cornillie)

# TR NEWS

features articles on innovative and timely research and development activities in all modes of transportation. Brief news items of interest to the transportation community are also included, along with profiles of transportation professionals, meeting announcements, summaries of new publications, and news of Transportation Research Board activities.

## TR News is produced by the Transportation Research Board Publications Office

Javy Awan, Editor and Publications Director  
Lea Camarda, Assistant Editor  
Jennifer J. Weeks, Photo Researcher  
Juanita Green, Production Manager  
Michelle Wandres, Graphic Designer

## TR News Editorial Board

Frederick D. Hejl, Chairman  
Jerry A. DiMaggio  
Charles Fay  
Christine L. Gerencher  
Edward T. Harrigan  
Christopher J. Hedges  
Russell W. Houston  
Katherine Kortum  
Thomas R. Menzies, Jr.  
G.P. Jayaprakash, Research Pays Off Liaison

## Transportation Research Board

Robert E. Skinner, Jr., Executive Director  
Suzanne B. Schneider, Associate Executive Director  
Mark R. Norman, Director, Technical Activities  
Stephen R. Godwin, Director, Studies and Special Programs  
Gary J. Walker, Director, Administration and Finance  
Christopher W. Jenks, Director, Cooperative Research Programs  
Ann M. Brach, Director, SHRP 2

TR News (ISSN 0738-6826) is issued bimonthly by the Transportation Research Board, National Research Council, 500 Fifth Street, NW, Washington, DC 20001. Internet address: [www.TRB.org](http://www.TRB.org).

**Editorial Correspondence:** By mail to the Publications Office, Transportation Research Board, 500 Fifth Street, NW, Washington, DC 20001, by telephone 202-334-2972, by fax 202-334-3495, or by e-mail [jawan@nas.edu](mailto:jawan@nas.edu).

**Subscriptions:** North America: 1 year \$55; single issue \$10. Overseas: 1 year \$80; single issue \$14. Inquiries or communications concerning new subscriptions, subscription problems, or single-copy sales should be addressed to the Business Office at the address below, or telephone 202-334-3216, fax 202-334-2519. Periodicals postage paid at Washington, D.C.

**Postmaster:** Send changes of address to TR News, Transportation Research Board, 500 Fifth Street, NW, Washington, DC 20001.

**Notice:** The opinions expressed in articles appearing in TR News are those of the authors and do not necessarily reflect the views of the Transportation Research Board. The Transportation Research Board and TR News do not endorse products or manufacturers. Trade and manufacturers' names appear in an article only because they are considered essential.

Printed in the United States of America.

Copyright © 2013 National Academy of Sciences. All rights reserved. For permissions, contact TRB.

**43 Grade Crossing Electronic Document Management Systems: Developing a Cost-Effective, Comprehensive Inventory and Project Management Tool**

Steve Laffey

**44 On Track for Railroad Crossing Safety: North Carolina's Sealed Corridor Program**

Paul C. Worley

**45 Developing and Implementing Positive Train Control at BNSF Railway**

Larry Milhon

In response to requirements in the Rail Safety Improvement Act of 2008, BNSF Railway is developing and implementing an electronic train management system to prevent train-to-train collisions, overspeed derailments, incursions into work zones, and movements through improperly aligned switches. The author describes the testing and application of research findings and the progress to date.

**49 Mobile Locomotive Simulator for Human Factors Research: The Federal Railroad Administration's Cab Technology Integration Laboratory**

Gina Melnik

**50 Trip Optimizer: Autocontrol System Saves Fuel**

Suneil Kuthiala

**52 POINT OF VIEW**

**Diverse Motivations Strengthen Rail Research**

Anthony Perl

Railroad research reflects diverse priorities—the varied needs of carriers, shippers, travelers, and government—as well as the distinctive means for seeking new knowledge preferred by industry, government, and universities, the author notes. Each of these orientations brings strengths to measuring and managing research, and aligning the motivations can enhance the effectiveness of rail research.

## ALSO IN THIS ISSUE:

**55 Research Pays Off  
Improving Railroad Track  
Maintenance Scheduling  
with Operations Research  
Techniques**

Yanfeng Ouyang

Second Strategic Highway Research Program News, 60

Launch Pad for Transportation Careers: Four Years of TRB's Minority Student Fellows Program, 61

Karen Febey

Increasing Opportunities for Women in Transportation: White House Forum Invites Discussion, 63

Katherine F. Turnbull and  
Marsha Anderson Bomar

**57 Calendar**

**58 Profiles**

Transportation policy professor Anthony D. Perl and freight researcher and rail consultant Peter F. Swan

**60 TRB Highlights**

Cooperative Research Programs News, 60

**64 News Briefs**

**65 Bookshelf**

## COMING NEXT ISSUE

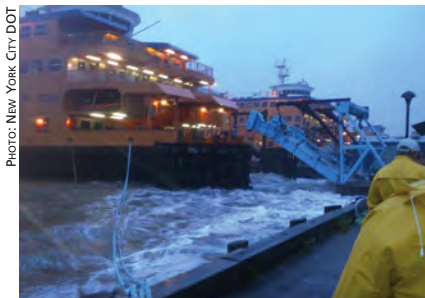

Staten Island Ferry crew and landside staff set heavy water moorings in advance of Superstorm Sandy, October 2012, at the Ferry Maintenance Facility in New York City harbor.

The logistics of disaster response and business continuity is the focus of articles in the July–August TR News, examining supply chain performance challenges in a crisis, the role of the private sector in maintaining supply chains for relief efforts, recent lessons learned for postdisaster relief logistics, and a state department of transportation's emergency management program—plus reports on the effect of gasoline shortages after a disaster, the role of ferries in rescue efforts, applications of social media in disaster preparation and in response and recovery, contingency planning for airport irregular operations, and more.

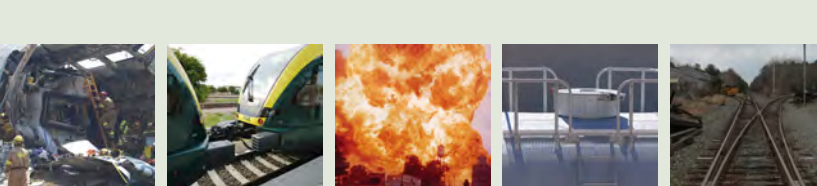

INTRODUCTION

# Railroads and Research Sharing Track

JOHN TUNNA AND DEBORAH BUTLER



*Tunna is Director, Office of Research and Development, Federal Railroad Administration, Washington, D.C. Butler is Executive Vice President, Planning, and CIO, Norfolk Southern Corporation, Norfolk, Virginia, and Chair of the TRB Executive Committee.*

**R**esearch has helped keep railroads running efficiently and safely since the early days in the 19th century, when August Wöhler conducted fatigue tests on railway axles. This special issue of *TR News* provides many examples of this tradition continuing today. The railroad industry successfully provides safe and efficient freight and passenger transportation largely by implementing research results. Examples highlighted in this issue are drawn from the disciplines of civil, mechanical, and electrical engineering and from the science of human factors.

David Tyrell and Jeff Gordon present the story of improved passenger vehicle crashworthiness. Incorporating results from 20 years of modeling, testing, and analysis, new passenger vehicles are entering operation in the United States with inherently safe designs.

Improvements in tank car safety in the past 20 years have been a success story for the industry. Christopher P. L. Barkan, M. Rapik Saat, Francisco González, III, and Todd T. Treichel supply the research and development perspective on this achievement.

Ted Sussmann of the Volpe Center and coauthors David Read, John Choros, and Shane M. Farritor describe the research and development supporting inspections of track for quality and defects. Of all railroad components, track has one of the most demanding roles, as expectations increase for higher axle loads, faster train speeds, and longer service lives. Modern inspection methods have ensured the achievement of all three of these goals.

Changing a safety culture modeled on a military-style chain of command to become more open and ready to share best practices is the focus of an article by Joyce M. Ranney, Michael K.

Zuschlag, Jonathan Morell, Michael K. Coplen, Jordan Multer, and Thomas G. Raslear. The authors describe pilot programs that have achieved impressive improvements in safety and accident prevention. The industry is quickly adopting and applying the proven procedures and techniques.

Highway-rail grade crossings are the most significant causes of railroad fatalities, second only to trespassing. Research into grade crossing safety brings together the science of human behavior with engineering technology. Suzanne M. Horton and Marco P. da Silva describe several success factors in improving grade crossing safety.

Larry Milhon describes the evolution of the electronic train management system at BNSF Railway. Through research and testing, this system is gaining enhancements and is poised to become BNSF's solution in meeting the mandate for positive train control.

Anthony Perl, who contributed a Point of View column in the *TR News* special edition on passenger rail in 2002, offers a perspective on "the forces that shape research performance." How have the hopes expressed 10 years ago been fulfilled?

Some themes emerge from the articles assembled in these pages. Research projects have long life cycles. In a mature industry, the easy-to-solve problems already have been addressed. Thanks in part to Wöhler's early work, broken axles are rare today. The remaining problems are tough and call for the collaborative efforts of government, railroads, suppliers, and academia to achieve solutions. Continued funding for rail research is needed, along with the support offered by the Transportation Research Board and its associated rail committees.

Appreciation is expressed to TRB Senior Program Officer Christine L. Gerencher for her work in coordinating this issue of *TR News*.



PHOTO: METROLINK

The Metrolink train accident in Glendale, California, in 2005 involved three trains and resulted in 11 fatalities and many injuries.

**Railroads and  
Research**  
Sharing Track

# Crash Energy Management

An Overview of Federal Railroad Administration Research

DAVID TYRELL AND JEFF GORDON

Tyrell is Senior Technical Advisor, Structures and Dynamics Division, Volpe National Transportation Systems Center, Cambridge, Massachusetts, and Gordon is Program Manager, Passenger Equipment Safety Research, Office of Research and Development, Federal Railroad Administration, Washington, D.C.

A crashworthy vehicle preserves space for the occupant to ride out a collision and limits the forces imparted to the occupant to survivable levels. The foundation for crashworthiness is achieved by designing and fabricating a strong principal car body structure within the limits of space and weight.

Crash energy management (CEM) is a design technique that enhances crashworthiness. CEM seeks to control the load path into the car body structure and to absorb the energy with components that are outside the occupied volume. CEM is commonly understood in the context of automobile designs that incorporate “crumple zones” and passive safety features—such as seat belts—to protect occupants. Passenger rail car construction has adopted these concepts, primarily as a result of European practice.

Crashworthy designs incorporating CEM can be accomplished with computer-aided engineering.

For more than 100 years, conventionally designed car bodies have been built to support high loads without sustaining damage. This approach offers advantages, such as ease of design and demonstra-



PHOTO: FRA

A frame from the conventional train-to-train impact test captures the moment of override.

tion of compliance, but has a limitation—only one car may crush and absorb energy in a train-to-train collision.

Conventional crashworthy designs can be accomplished with straightforward calculations. Compliance can be demonstrated by applying a high load to a car body and carefully inspecting the car body to make sure it looks the same after the test as it did before the test. Because only one car may crush in a collision, the crush can be extensive, and occupied volume may be lost.

## Crashworthiness Research

For nearly 20 years, the Office of Research and Development of the Federal Railroad Administration (FRA) has been investigating crashworthiness strategies that will ensure the preservation of occupied space and limit the severity of the secondary impact environment to which the occupants are exposed. One effective crashworthiness strategy is to build car body end structures that systematically collapse when overloaded. CEM strategies have improved the performance of freight locomotives (1), tank cars carrying hazardous materials (2), and passenger trains (3) in accidents.

The crashworthiness research by FRA's Office of Research and Development assesses the likelihood and extent of damage from accidents and develops accident scenarios. Safety strategies to mitigate the consequences of the scenarios—including the development of technologies to improve occupied volume preservation, injury prevention, fuel containment, and glazing impact resistance—are considered, analyzed, and tested. This research produces the information to understand and apply the technology to the rail industry. The information may be used to engineer equipment, verify performance, inform policy decisions, and support standards development.

From 1999 to 2005, FRA conducted a series of six impact tests to assess the crashworthiness of rail passenger equipment, both conventional and with CEM features. The CEM designs included energy-absorbing crush zones, located at the ends of each car. The results showed that CEM features can improve crashworthiness significantly. Full participation by the rail industry contributed to the success of these tests.

## Implementing the Results

The Los Angeles commuter railroad Metrolink has used the findings from the impact tests to develop specifications for the crashworthiness features of new equipment. The research also has helped lay the technical foundation for assessing the crashworthiness and occupant protection performance of alternatively designed train sets for Tier I passenger service, which

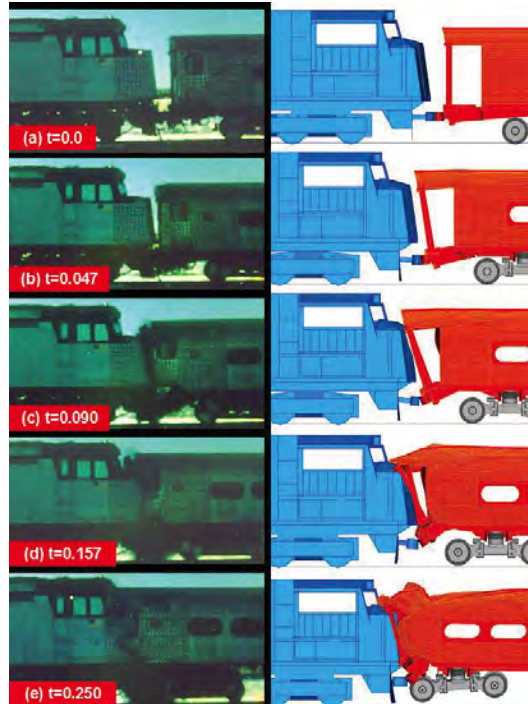

A crash energy management (CEM) impact test sequence shows car body end structures that systematically collapse when overloaded, limiting the secondary impact of the crash.

does not exceed 125 mph (4). In addition, the results have assisted FRA's Railroad Safety Advisory Committee (RSAC) in developing recommended crashworthiness requirements for high-speed trains (5).

New equipment specifications increasingly are incorporating CEM, as evidenced by a suite of specifications developed for the next generation of passenger equipment. For example, the procurement of a fleet of bilevel cars for California and the Midwest, now under way, specifies CEM standards.

Metrolink and other rail agencies are incorporating CEM in new equipment specifications.

PHOTO: DON BARRETT





PHOTO: VOAFR CENTER

An April 2002 crash in Placentia, California.

## Stakeholder Involvement

Government and industry working groups are committed to increasing railroad safety. Some of these groups are government-led, such as the RSAC (6); some are industry-led, such as the American Public Transportation Association's (APTA's) Passenger Rail Equipment Safety Standards Committee<sup>1</sup> (PRESS); and others are jointly led, such as the Passenger Rail Equipment and Improvement Act Section 305 Next-Generation Corridor Equipment Pool Committee.<sup>2</sup>

Whatever their makeup, these groups include the participation of all interested stakeholders: railroads,

<sup>1</sup> [www.aptastandards.com/StandardsPrograms/PRESSStandardsProgram/tabid/59/language/en-US/Default.aspx](http://www.aptastandards.com/StandardsPrograms/PRESSStandardsProgram/tabid/59/language/en-US/Default.aspx).

<sup>2</sup> [www.ngec305.org](http://www.ngec305.org).

suppliers, labor, government agencies, and consultants. The groups address all aspects of railroad safety, including equipment safety, track safety, and operating practices, and have helped develop FRA's passenger equipment safety standards (7), FRA's locomotive crashworthiness standards (8), the Association of American Railroads' locomotive crashworthiness standards,<sup>3</sup> FRA's cab car end frame requirement (9), and APTA's standard for the design and construction of passenger railroad rolling stock.<sup>4</sup>

A timeline for the formation of the various working groups, along with major passenger train accidents and related crashworthiness research, is shown on page 8. Accident investigations inform the research, and the working groups apply the results to develop regulations, standards, and specifications. The new requirements in turn influence the next generation of rail equipment.

## Four-Phase Approach

The approach to research and the application of results consists of four phases, illustrated in Figure 1 (page 7):

1. Accident investigations assemble a sequence of events leading to injury or fatality.
2. The equipment performance is analyzed, and

<sup>3</sup> AAR S-580, December 2004, revised 2008.

<sup>4</sup> [www.aptastandards.com/portals/0/PRESS\\_pdfs/Construct/construct%20reaffirm/APTA%20SS-CS-034-99%20Rev%202-Approved.pdf](http://www.aptastandards.com/portals/0/PRESS_pdfs/Construct/construct%20reaffirm/APTA%20SS-CS-034-99%20Rev%202-Approved.pdf).



PHOTO: VOAFR CENTER

Accident investigators on scene at a 2008 rail accident in Chatsworth, California. Research and application of results progress through four phases: accident investigation; equipment analysis and design testing; development of specifications and standards; and improved equipment design.

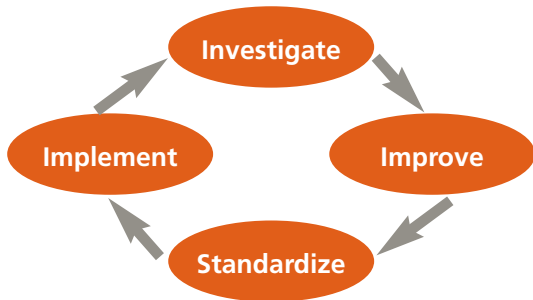

**FIGURE 1** Approach to engineering research on rail equipment crashworthiness.

potential improvements are explored. Conventional and improved designs are tested, and the results are compared.

3. Specifications and standards are developed from the results of the accident investigations, analyses, and tests.

4. Improved equipment is designed according to the evolving standards and is introduced into service.

As technological advances show promise for improved performance, the phases can proceed in an evolutionary fashion, with continuous research leading to continuously improving standards and safer designs.

### CEM Research Participants

The CEM research demonstrates FRA's work to engage the full spectrum of stakeholders to ensure the successful implementation of findings:

- ◆ APTA's PRESS Committee coordinated industry participation, including passenger railroad operators, suppliers, labor organizations, and consultants to assist FRA in the planning and conduct of the impact test program. The PRESS Construction and Structural Subcommittee acted as a board of directors for the tests.

- ◆ Southeastern Pennsylvania Transportation Authority, the Philadelphia commuter railroad; Long Island Railroad, one of the New York City–area commuter railroads; and Amtrak provided the cars and locomotives for testing.

- ◆ Bombardier and ElectroMotive Diesel provided structural information for the cars and locomotives.

- ◆ Tiax, with Taylor Raynauld Amar and Associates, consultants to FRA and the Volpe Center, designed the detailed CEM modifications to the conventional equipment.

- ◆ Transportation Technology Center, Inc., under contract to FRA, performed the tests.

- ◆ Under the sponsorship of FRA, the Volpe Center designed the tests and oversaw the engineering.



PHOTO: VOLPE CENTER

### Full-Scale Tests

Six tests were conducted to measure crashworthiness performance—three kinds of tests each for conventional equipment and equipment incorporating CEM features (10):

1. The impact of a single car into a fixed barrier,
2. The impact of two coupled cars into a fixed barrier, and
3. The collision of a train led by a cab car into a standing conventional locomotive-led train.

The six full-scale tests consisted of three tests each of conventional and of CEM cars: a single car into fixed barrier (*conventional, shown*), two coupled cars into a fixed barrier, and one train into another.

The single-car test recorded the force required to reduce the length of the passenger car, as well as the changes in the geometry of the car as its length was reduced. The two-car test added information about the interaction of coupled passenger cars. The train-to-train test provided information about the interaction of colliding cars, as a passenger car with an operator's control stand—that is, a cab car—led train—collided with a locomotive-led train at 30 mph.

Cars used in CEM tests were modified to include crush zones and bolsters on the ends.



PHOTO: VOLPE CENTER





In tests of a single, conventional rail car crashing into a fixed barrier, the car body crippled haphazardly (*left*). The CEM equipment systematically absorbed the energy from the impact (*right*).

For the CEM tests, cars used in the conventional tests were modified to include crush zones on the ends (11). The center portions of the cars, between the body bolsters, were not modified, so that the strength of the primary structures remained unchanged.

### Test Results

In the single-car test of conventional equipment, the car body crippled haphazardly when the peak force was reached (12). In the single-car test of CEM equipment, the crush zone systematically absorbed energy (13). The wheels remained on the track during the single-car test of CEM equipment, but the lead truck derailed during the single-car test of conventional equipment.

In the two-car test of conventional equipment, the lead car crushed in essentially the same way as the conventional car in the single-car test; the trailing car suffered little structural damage (14). In the two-car test of CEM equipment, the forward and rear crush zones of the lead car and the forward crush zone of the trailing car were activated; the cars remained in line, and the loads transmitted between the cars remained aligned with the stronger structural elements (15).

In the train-to-train test of conventional equipment, the front third of the colliding cab car was crushed, with little damage to any of the other equipment. In the conventional train-to-train test, the cab car lost the space for the operator and 47 passengers (16). For the CEM equipment, the impacting CEM cab car and conventional locomotive remained in-line and engaged. The crush was distributed among all of the cars of the passenger train. The CEM train-to-train test preserved the entire occupied volume for the passengers and crew (17).

### Timeline of Working Group Formation, Significant Accidents, and Related FRA Research and Development Activities

|                    |  |
|--------------------|--|
| March 15, 1999     | Bourbonnais, Illinois, passenger train–truck collision   |
| May 12, 1999       | Passenger Equipment Safety Standards Final Rule published  |
| November 16, 1999  | Conventional design single-car impact test   |
| April 4, 2000      | Conventional design two-car impact test  |
| January 31, 2002   | Conventional design train impact test  |
| April 23, 2002     | Placentia, California, train collision   |
| 2003               | FRA RSAC Crashworthiness–Glazing Task Force  |
| December 3, 2003   | CEM single-car impact test   |
| February 26, 2004  | CEM two-car impact test  |
| 2005               | FRA–Federal Transit Administration–American Public Transportation Association Ad Hoc CEM Working Group     |
| January 26, 2005   | Glendale, California, passenger train crash  |
| September 17, 2005 | Chicago, Illinois, passenger train derailment  |
| March 23, 2006     | CEM train impact test  |
| 2008               | Waiver requests: Caltrain 2025, California High-Speed Train Project, Dallas Area Rapid Transit, and others |
| September 12, 2008 | Chatsworth, California, train collision  |

### CEM Specification

At the time of the Glendale incident in January 2005, Metrolink was preparing to purchase new equipment. The accident involved three trains, resulted in 11 fatalities and many serious injuries, and was investigated in an ongoing FRA field study of occupant injury in passenger train collisions and derailments (18).

Metrolink sought to apply results from the FRA crashworthiness research in the procurement. APTA and Metrolink collaborated with FRA and the Federal Transit Administration (FTA) to form an ad hoc CEM Working Group of stakeholders in May 2005.

In approximately four months, the group developed a detailed specification for a CEM cab car–led train that was as crashworthy as a conventional locomotive-led train (19). Metrolink’s commitment, the availability of well-developed technical information, the sustained commitment to railroad safety by gov-

ernment and industry groups, and the support of FRA, FTA, and APTA management and representatives contributed to this success.

The specification prescribes performance requirements for the train, the cab, the trailer cars, and the CEM mechanisms. Each requirement includes quantitative criteria for evaluating compliance. Components critical to the functioning of the crush zone underwent destructive testing, to ensure that the performance requirements were achieved.

Metrolink released the specification, including the CEM recommendations, on September 16, 2005, as part of an invitation for bids. The contract for the equipment manufacturing was awarded to Rotem, a division of Hyundai, now Hyundai Rotem Company. Rotem developed a shaped-nose, CEM design for the new Metrolink cab cars (see photograph, page 10). This equipment went into service in December 2010.

## Ongoing Activities

Until recently, the rail industry had relied on non-destructive tests and manual calculations to demonstrate crashworthy designs that complied with regulations. Classical engineering beam and elastic analyses have assured that the structures can support high loads without damage or “permanent deformation.”

Much of the technology that was developed from the test program has relied on computer simulations and destructive testing of critical components to

PHOTO: VOIPE CENTER



In the coupled-car tests of conventional equipment, the lead car crumpled while the trailing car stayed mostly intact; the load path was distorted.

demonstrate performance. Uniform practices are being developed for applying computer simulations, to assure a shared understanding by the railroads, rail equipment suppliers, and FRA. The RSAC's Engineering Task Force is performing much of the work for establishing industry best practices.

Related FRA research has addressed occupied volume integrity (20), to facilitate alternatives to the long-standing end strength requirement of 800,000 lb for conventional equipment (4). Other research includes the development of prototype CEM components for locomotives (1). CEM research findings also have benefited FRA research to improve the integrity of tank cars carrying hazardous materials (2).



The colliding CEM car and conventional locomotive remained in-line and engaged in train-to-train impact tests.

Metrolink's new cars feature a shaped-nose, CEM design, manufactured by Hyundai Rotem Company.



FRA and industry are working together to address and cope with a range of safety concerns. The CEM tests and the application of the research results to improve railroad safety exemplify FRA's successful influence on railroad safety culture.

## References

1. Llana, P., and R. Stringfellow. *Preliminary Development of Locomotive Crashworthy Components*. Paper No. JRC2011-56104, American Society of Mechanical Engineers, March 2011.
2. Jeong, D. Y., D. C. Tyrell, M. E. Carolan, and A. B. Perlman. *Improved Tank Car Development: Ongoing Studies on Sandwich Structures*. Paper No. JRC2009-63025, American Society of Mechanical Engineers, March 2009.
3. Jacobsen, K. *Collision Dynamics Modeling of Crash Energy Management Passenger Rail Equipment*. Master's thesis. Tufts University, January 2008.
4. *Technical Criteria and Procedures for Evaluating the Crashworthiness and Occupant Protection Performance of Alternatively-Designed Passenger Rail Equipment for Use in Tier I Service*. DOT/FRA/ORD-11/22. Federal Railroad Administration, U.S. Department of Transportation, October 2011.
5. Docket No. FRA-2000-7257; Notice No. 71, Railroad Safety Advisory Committee (RSAC) Working Group Activity Update. *Federal Register*, Vol. 77, No. 184, September 21, 2012.
6. Docket No. RSAC-96-1, Railroad Safety Advisory Committee Establishment. *Federal Register*, Vol. 61, No. 48, March 11, 1996.
7. 49 CFR Part 238, Passenger Equipment Safety Standards: Final Rule. *Federal Register*, Vol. 64, No. 91, May 12, 1999.
8. 49 CFR Parts 229 and 238, Locomotive Crashworthiness: Final Rule. *Federal Register*, Vol. 71, No. 124, June 28, 2006.
9. 49 CFR Appendix F to Part 238, Alternative Dynamic Performance Requirements for Front End Structures of Cab Cars and MU Locomotives. *Federal Register*, Vol. 75, No. 5, January 8, 2010.
10. Tyrell, D., K. Severson, A. B. Perlman, B. Brickle, and C. VanIngen-Dunn. Rail Passenger Equipment Crashworthiness Testing Requirements and Implementation. *Rail Transportation 2000*, Vol. 19, 2000.
11. Mayville, R. A., K. N. Johnson, R. G. Stringfellow, and D. C. Tyrell. *The Development of a Rail Passenger Coach Car Crush Zone*. Paper No. JRC2003-1653, American Society of Mechanical Engineers, April 2003.
12. Tyrell, D., K. Severson, and A. B. Perlman. *Single Passenger Rail Car Impact Test, Volume I: Overview and Selected Results*. DOT/FRA/ORD-00/02.1. Federal Railroad Administration, U.S. Department of Transportation, March 2000.
13. Jacobsen, K., D. Tyrell, and A. B. Perlman. *Impact Test of a Crash-Energy Management Passenger Rail Car*. Paper No. RTD2004-66045, American Society of Mechanical Engineers, April 2004.
14. Tyrell, D., K. Severson, J. Zolock, and A. B. Perlman. *Passenger Rail Two-Car Impact Test, Volume I: Overview and Selected Results*. DOT/FRA/ORD-01/22.1. Federal Railroad Administration, U.S. Department of Transportation, January 2002.
15. Jacobsen, K., D. Tyrell, and A. B. Perlman. *Impact Tests of Crash Energy Management Passenger Rail Cars: Analysis and Structural Measurements*. Paper No. IMECE2004-61252, American Society of Mechanical Engineers, November 2004.
16. Tyrell, D. *Passenger Rail Train-to-Train Impact Test, Volume I: Overview and Selected Results*. DOT/FRA/ORD-03/17.1. Federal Railroad Administration, U.S. Department of Transportation, July 2003.
17. Tyrell, D., K. Jacobsen, and E. Martinez. *A Train-to-Train Impact Test of Crash Energy Management Passenger Rail Equipment: Structural Results*. Paper No. IMECE2006-13597, American Society of Mechanical Engineers, November 2006.
18. Parent, D., D. Tyrell, K. Jacobsen, and K. Severson. *Crashworthiness Analysis of the January 26, 2005, Glendale, California Rail Collision*. Paper No. JRC2011-56132, American Society of Mechanical Engineers, March 2011.
19. Tyrell, D., E. Martinez, K. Jacobsen, D. Parent, K. Severson, M. Priante, and A. B. Perlman. *Overview of a Crash Energy Management Specification for Passenger Rail Equipment*. Paper No. JRC2006-94044, American Society of Mechanical Engineers, April 2006.
20. Carolan, M., A. B. Perlman, and D. Tyrell. *Alternative Occupied Volume Integrity (OVI) Testing and Analyses*. Federal Railroad Administration, U.S. Department of Transportation, 2013 (in publication).

# Realizing the Potential of Diesel Multiple-Unit Technology

## Research Overcomes Barriers

THOMAS C. CORNILLIE

Designers of railroad vehicles long have recognized the efficiencies achievable by locating propulsion within a passenger-carrying vehicle, eliminating the need for a separate locomotive. Although various designs of vehicles powered by steam- and gasoline-fueled engines came into service starting in the 1890s, “diesel multiple unit” (DMU) emerged as a term-of-art in the late 1930s to describe vehicles that could operate as single cars or be combined to form a longer train.

For the past 60 years, the rail diesel car (RDC) has epitomized DMU technology in North America. The Budd Company of Philadelphia built nearly 400 RDCs between 1949 and 1962. These cars quickly gained a reputation for reliability, for adaptability to a range of services, and for the ease of making incremental technological upgrades.

As federal policy structures for supporting transit investments solidified in the 1970s, DMU technology offered a way to improve the efficiency of commuter rail service. Revenue service demonstrations of European DMUs were carried out with federal funding; however, these efforts did not lead to the deployment of new technology. Moreover, in 1979, the Budd Company released an updated version of the RDC, dubbed the SPV-2000, but few orders and a checkered mechanical reputation limited the model’s role in the North American market.

In other nations, DMU designs continued to advance. By the turn of the 21st century, DMUs were providing the majority of nonelectrified intercity and commuter rail services in Britain, and a significant portion of passenger services across continental Europe and in Japan. Certain Federal Railroad Administration (FRA) regulations affecting North American design practices, however, slowed efforts to import internationally developed vehicle designs.

This situation changed with a confluence of research by the U.S. Department of Transportation’s Volpe Center using FRA funding, with input from the American Public Transportation Association’s Passenger Rail Equipment Safety Standards task force and with updated research into the relative economies of DMU technology. Salient in these efforts was the consideration of crash energy management (CEM) technologies, a standard in DMU vehicle designs in international applications.

Research proving the effectiveness of CEM in meeting

---

*The author is Principal, Thomas Cornillie Independent Scholar, Alameda, California, and Chair of the Research Subcommittee of the TRB Commuter Rail Committee.*



PHOTO: THOMAS C. CORNILLIE

*The Denton County Transportation Authority operates DMU vehicles between Denton, Texas, and a connection with the Dallas Area Rapid Transit System at Carrollton. Couplings that consolidate power and control connections into a single couple—a standard feature on current DMU designs—facilitate adapting train configuration to ridership demand.*

the intent of FRA crashworthiness regulations, coupled with regulatory reforms, has opened the door in American and Canadian cities to DMUs incorporating proven Asian and European designs. Implementation of these vehicles realizes long-sought cost efficiencies and provides other improvements, such as low-floor boarding, which reduces dwell times and improves accessibility.

TRB meetings and publications have provided forums for sharing news about emerging technologies and major trends and for articulating research needs, identifying applications for DMU technology in the United States. Through TRB’s Commuter Rail Committee and its Self-Powered Vehicle Subcommittee, research into the economic characteristics of DMU operations and technology innovations continue to be discussed and shared.



PHOTO: KIMURA, WIKIMEDIA COMMONS

*A DMU at an East Japan Railway Company station in Hitachiomiya, Japan. DMUs provide a large share of intercity and commuter rail services in Japan.*

Testing of tank car thermal protection at the Transportation Technology Center near Pueblo, Colorado, in the early 1970s helped quantify the rate of heat transfer into a tank under intense fire conditions.

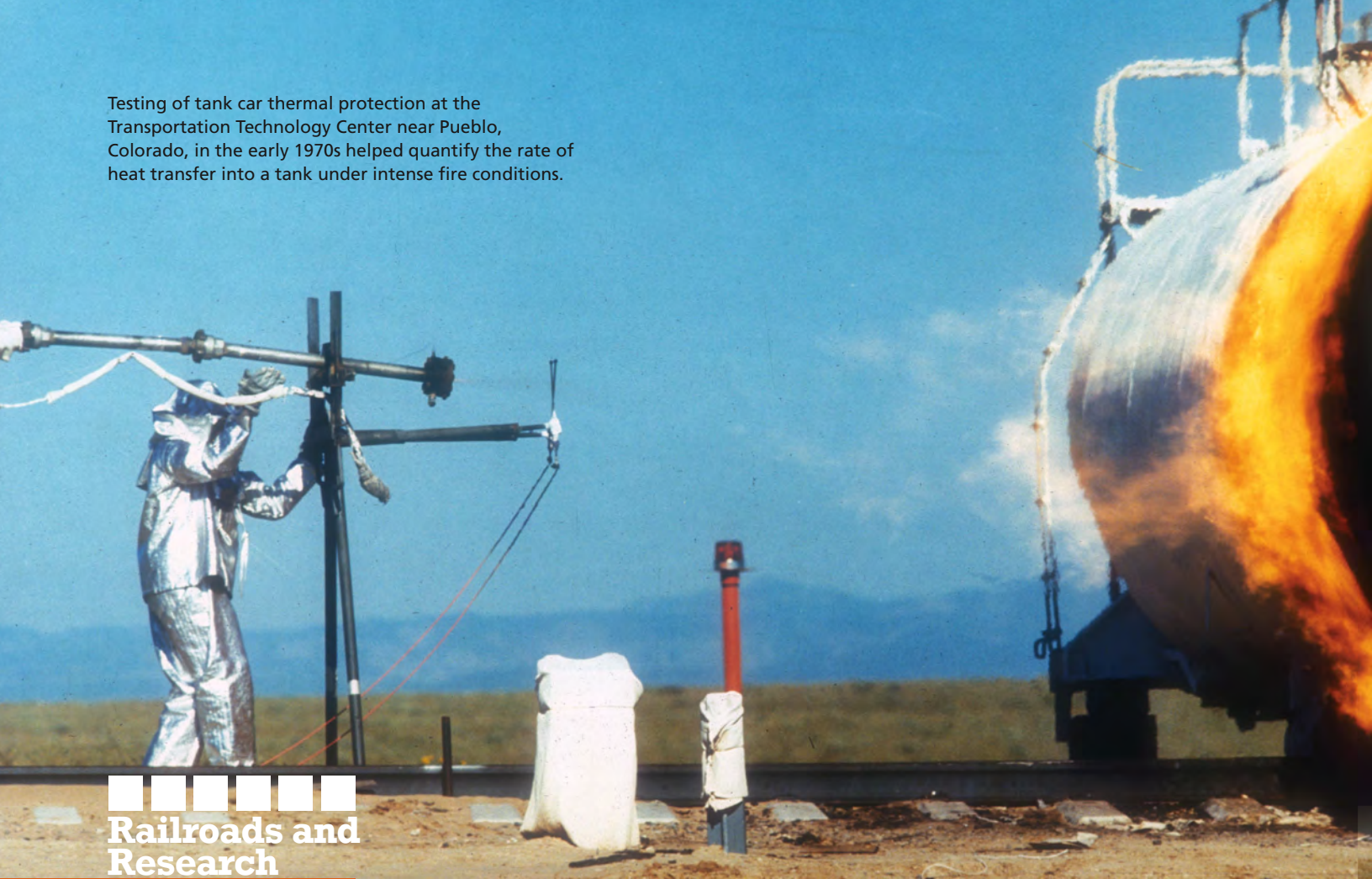

■ ■ ■ ■ ■ ■ ■ ■  
**Railroads and  
Research**  
Sharing Track

# Cooperative Research in Tank Car Safety Design

How Science and Engineering Are Reducing the Risk of Rail Transport of Hazardous Materials

**CHRISTOPHER P. L. BARKAN, M. RAPIK SAAT,  
FRANCISCO GONZÁLEZ, III, AND TODD T. TREICHEL**

*Barkan is Professor, Department of Civil and Environmental Engineering, and Executive Director, Rail Transportation and Engineering Center, University of Illinois at Urbana-Champaign. Saat is Research Assistant Professor, University of Illinois at Urbana-Champaign. González is Hazardous Materials and Tank Car Project Manager, Office of Research and Development, Federal Railroad Administration, Washington, D.C. Treichel is Director, Railway Supply Institute-Association of American Railroads Railroad Tank Car Safety Research and Test Project, Leesburg, Virginia.*

**R**ailroad tank car safety in North America has improved continuously through cooperative testing, research, and standards development by industry and government. Although much of this progress has been evolutionary, in recent decades more revolutionary approaches have taken hold.

The railroad, tank car, and petrochemical industries have worked together with the government to develop and improve safety design standards for tank cars since the early 20th century (1). In 1903, the Master Car Builders' Association formed the Committee on Tank Cars, composed of the mechanical officers from several railroads and a representative from Union Tank Line, then the major tank car owner. The committee recommended practices that were soon established as industry standards for the construction and repair of tank cars.

The American Railway Association and its successor, the Association of American Railroads (AAR), later adopted the standards. The AAR Tank Car Committee is charged with reviewing and revising standards to advance tank car safety.

The public's interest was represented early on—in 1912, the Interstate Commerce Commission referenced the tank car standards as the basis for federal regulations. The public sector's oversight role—now under the auspices of the U.S. Department of Transportation (DOT)—has expanded (2), as private- and public-sector stakeholders work toward the common goal of ever-safer transportation of hazardous materials.

## Improving Tank Car Safety

The substantial economies offered by the safe, reliable bulk transport of petroleum and chemical products led to a proliferation of increasingly specialized tank car designs to accommodate an extraordinary variety of hazardous and nonhazardous liquid products. As the tank car has evolved, new materials, designs, and manufacturing technologies have contributed to technical solutions for a variety of challenges.

Tank cars today are the second most common type of railroad freight car in North America, accounting for approximately 20 percent of the rail car fleet. Each year, tank cars transport more than 1.6 million shipments of hazardous materials for a range of products and processes essential to the nation's economy, public health, and quality of life.

Nearly all of these shipments arrive safely at their destinations. Nevertheless, a train accident involving tank cars may release a hazardous material with a potential to harm humans, property, and the environment.

Building on a century of cooperative efforts, government and industry continue working together to improve tank car safety; recent design advances have followed three parallel and complementary approaches:

- ◆ Statistical analysis and optimization of safety design,
- ◆ Structural modeling, and
- ◆ Physical testing.

## Quantitative Analysis

A series of catastrophic tank car accidents in the late 1960s and early 1970s released flammable gases and toxic materials. Industry and government did not sufficiently understand the factors affecting these accidents and the principal failure modes that caused the releases. Two new cooperative research programs were initiated; one focused on train accident prevention and the other on tank car safety improvement.

The Railroad Tank Car Safety Research and Test Project started in 1970 under the auspices of the Railway Progress Institute—now the Railway Supply



Photo: AMERICAN CAR & FOUNDRY COMPANY, EDWARD S. KAMINSKI COLLECTION

Institute—and AAR. The project conducted research and testing with U.S. DOT to identify and evaluate design concepts for improving the damage resistance of tank cars in accidents. This research led to such now-common safety features as head shields, shelf couplers, and thermal protection on tank cars carrying materials that pose the highest hazard; these features protect against the most likely failure modes.

U.S. DOT regulations and AAR standards incorporating these safety features have reduced tank car releases in accidents substantially. As the first major design elements with the sole purpose of protecting tank cars from damage in accidents, these features were revolutionary in their time.

Although effective in tests, the new design elements required proof on cars in service. The RSI-AAR Safety Project therefore launched a parallel effort to record extensive information about tank car performance in accidents. In 43 years, the effort has collected data on more than 40,000 damaged tank cars and 26,000 accidents (3).

Complementing this database is the Railroad Accident–Incident Reporting System, which the Federal Railroad Administration (FRA) revamped and expanded in 1975 to improve analyses of accident causes and trends.

Together, these two databases—one on accident causes and characteristics, the other on damage to

Tank car built in 1924 by American Car & Foundry was state of the art for rail transport of chlorine.



An accident at Crescent City, Illinois, in 1970, released and ignited liquefied petroleum gas; industry and government soon launched new, cooperative research programs to improve railroad and hazardous materials transportation safety.

Physical tests of tank cars with head shields (left) and without head shields (right) were conducted in the 1970s. The head shield is designed to protect the end—or head—of the tank car from impacts in accidents.



the vehicles involved—provide an inferential capacity that is unparalleled in the safety databases for any other U.S. transportation mode or in any comparable rail safety database in the world. The databases enable detailed quantitative understanding of the frequency and severity of tank car accident failure modes and of the effects of different design features.

### Optimizing Safety Design

The expansion and refinement of the RSI-AAR database has allowed increasingly robust statistical analyses of the performance of tank car designs and variations. For the first time, the relative benefits of alternative tank car designs could be evaluated with “what if” analyses. The combinations of changes most likely to maximize safety benefits could be quantitatively assessed, leading to a new approach to improving tank car safety.

The traditional approach was to overpackage hazardous products—that is, to transport them in tanks with higher pressure specifications than necessary.

Now that the performance of each part of the tank car affecting safety could be quantified, an optimization model could be developed, combining the statistical estimates with data on tank car engineering design and economics, to assess the costs and potential benefits of candidate designs (4). The combinations offering the greatest benefit for the least cost—primarily represented as additional weight—could be identified (Figure 1, page 15).

Most tank car safety design enhancements involve thicker steel, which increases weight. Increasing a car’s weight, however, reduces its carrying capacity because of the maximum allowable gross rail load or total weight. This in turn may require more shipments and more railcars to move the same quantity of goods.

### Informing Standards

The optimization model revealed which combination of design features offered the greatest safety benefit for the least amount of incremental weight, helping

(Left:) Modern, nonjacketed tank car equipped with a half-height head shield. Many cars are built with a full-height head shield that is integral with a steel jacket enveloping the tank, to provide insulation or thermal protection.

(Right:) Double-shelf couplers are designed to prevent disengagement during derailments, so that adjacent cars cannot batter and puncture the tank car.

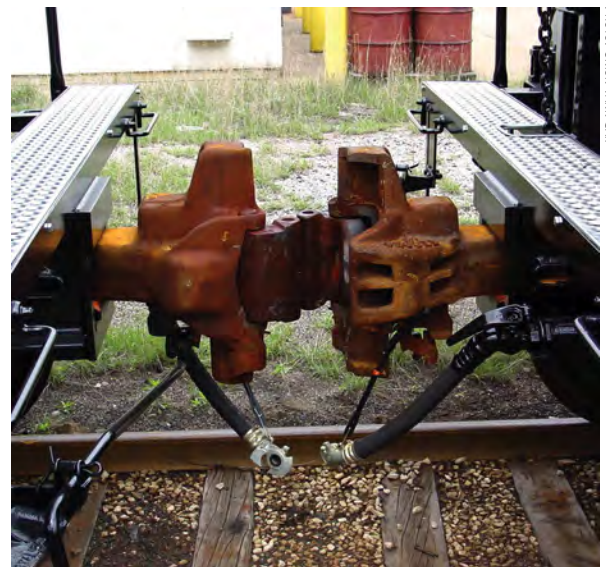

PHOTO: TRINITYRAIL

PHOTO: UNION TANK CAR

to identify the most efficient approaches to enhancing safety. The AAR Tank Car Committee used the tank car safety design optimization model results to develop several new standards, including design requirements for tank cars with higher carrying capacity (5).

One petition for U.S. DOT rulemaking led to new standards for toxic-inhalation hazard (TIH) tank cars (Figure 2, below). More than 1,600 new cars have been built since, and the risk of transporting TIH products in these cars has dropped by an estimated 60 to 65 percent. The AAR Tank Car Committee has used the results from the model to develop another petition for rulemaking for new, improved standards for flammable materials.

The optimization technique helps determine which combination of features will most efficiently achieve a given level of safety performance but does not answer the question, “how safe is safe enough?” Performance requirements of tank car designs vary widely, depending on the hazards associated with the material being transported. Industry and government have grappled with this question for decades, as understanding of different hazards has become more sophisticated, shipping patterns have changed, and societal expectations of tolerable risk have evolved.

### Clarifying Trade-Offs

Assigning relative value to harmful impacts can be technically challenging and sometimes controversial. Nevertheless, with improved quantitative rigor, decision making becomes more objective, traceable, and accountable, so that all parties are informed about the necessary trade-offs.

Analysis of the FRA and RSI-AAR databases yields information about risk and helps determine an appropriate level of safety to incorporate into tank car design. Safety design should be commensurate with the hazard posed by the materials, with more hazardous materials warranting greater protection.

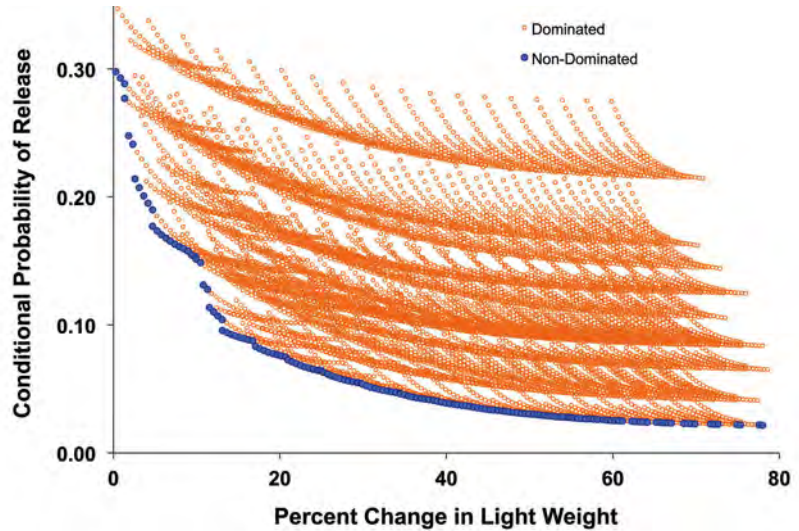

**FIGURE 1** Pareto optimal analysis of various combinations of tank car safety enhancements. The blue “nondominated” points represent the most efficient family of options to improve safety, minimizing the increase in tank car weight and consequent loss in capacity (4).

As noted, tank cars can be made safer by increasing the damage resistance of various components; however, this generally can have the effect of making the tank cars less efficient for transportation and more costly to purchase. University of Illinois researchers developed a quantitative framework to assess the cost of losses of different hazardous materials—the incremental benefit of avoided costs was compared with the cost of more robust tank cars. Higher-hazard materials offered larger benefits for an equivalent level of tank car safety improvement.

### New Safety Design Concepts

From 1980 to 2012, the rate of hazardous materials releases caused by train accidents declined by more than 90 percent as a result of tank car safety enhancements and of a dramatic reduction in accidents, as shown in Figure 3 (page 16). Several accidents in the mid-2000s, however, caused fatal releases of

**FIGURE 2** Results of simulated rollover analyses of (a) conventional top-fittings protection compared with (b) a new design for pressure tank cars.

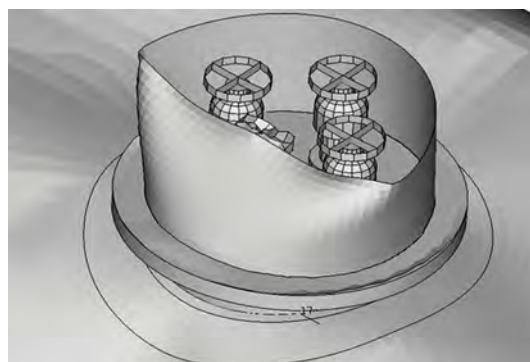

(a)

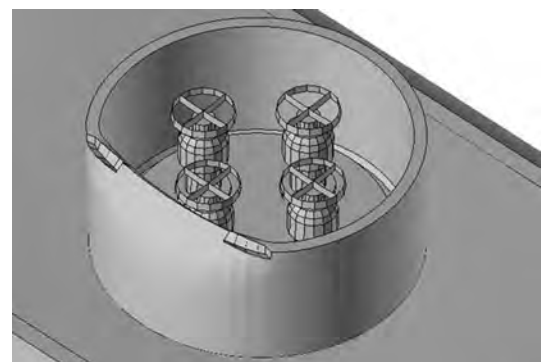

(b)



TIH tank car that conforms to new, more robust standards required by AAR and FRA. These cars are approximately 60 to 65 percent less likely to release their contents in an accident than cars conforming to the previous standard.

(Below, left:) Thermal protection can shield a tank and its contents from a buildup of heat-induced pressure in an accident that triggers an engulfing fire.

(Below, right:) Lower-profile protection for top fittings of TIH tank cars.



**FIGURE 3** The occurrence of hazardous materials releases caused by rail-road accidents has declined more than 90 percent since 1980, with improvements in tank car safety design and substantial reductions in accidents (Source: FRA).

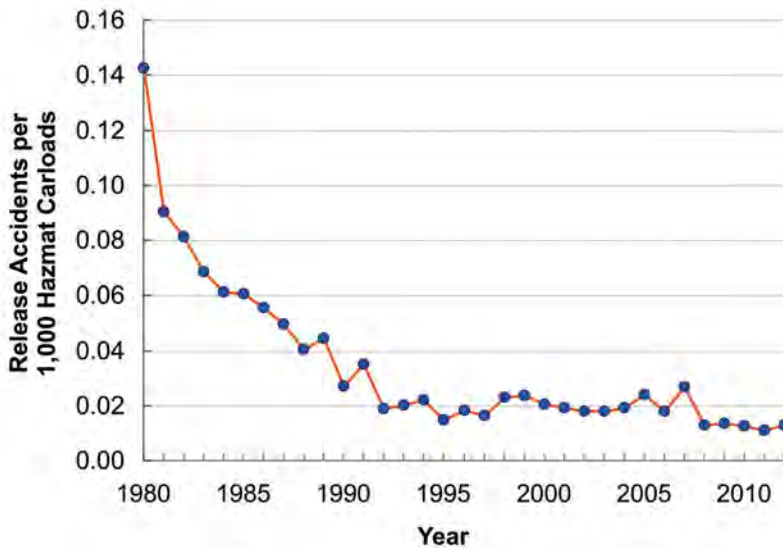

hazardous materials and stimulated renewed interest in tank car safety design.

Although further improvements were possible by making tank cars thicker and heavier, statistical analysis indicated diminishing returns to this approach. A consensus emerged that a more effective approach might be to consider new materials, structural designs, and components that would yield substantial safety benefits without as much additional weight.

In 2006 Dow Chemical, Union Pacific Railroad, and Union Tank Car Company formed a partnership to develop the next-generation rail tank car (NGRTC). The coalition soon expanded to include several other industry and academic partners, as well as U.S. DOT and Transport Canada, with the goal of improving tank car safety more effectively and efficiently. Extensive research explored innovative concepts in tank car crashworthiness, including

computer modeling of the dynamics of train derailment and tank car response (as shown in Figure 4, at right), materials testing, full-scale crash testing, and tank car design optimization modeling (4, 6, 7).

**Impact Tests**

This work included a series of full-scale impact tests that examined the puncture resistance of the tank car head and shell and evaluated the performance of several designs hit by impactors with different sizes, shapes, and speeds. Accelerometer measurements were converted into force and displacement histories to characterize the force-crush response of the tank. The data were compared with results from finite element analysis models developed to simulate the tests and were found to be in reasonable agreement.

FRA also conducted impact tests on high-strength, low-alloy steels in welded sandwich panels as a possible means of protecting tanks during impacts (8). In addition, FRA is studying the vulnerability of tank car fittings—such as valves and other appurtenances—in accidents. Full-scale rollover tests have quantified the nature and magnitude of the forces on the cars and appurtenances (9). The test data can be used to refine and validate models now in development to predict tank car behavior and performance in accidents (Figure 5, page 18).

Union Tank Car Company or UTLX has constructed several “Tank Cars of Tomorrow,” incorporating a tank-within-a-tank or sandwich design, along with other new safety features derived from the

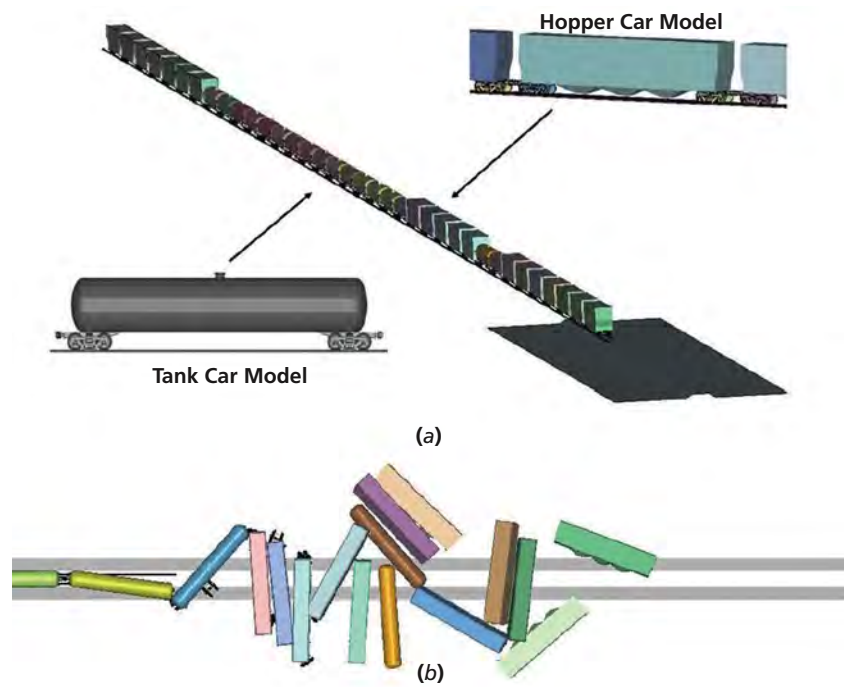

**FIGURE 4** Computer simulation models of the dynamics of train derailment were developed to understand the force of impacts on different parts of tank cars in accidents: (a) 36-car train model and (b) calculated response of train 25 seconds after derailment (7).

Full-scale impact test setup at the Transportation Technology Center for evaluating various safety improvement concepts in the Next-Generation Rail Tank Car project (7).



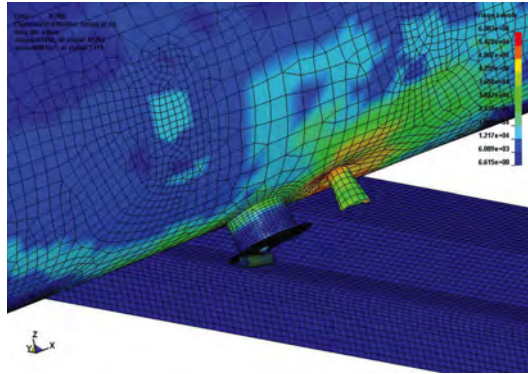

**FIGURE 5** A finite element analysis model simulating the response of the top fittings and the tank structure during a tank car rollover after derailment (9).

research and development under the Next-Generation Rail Tank Car Project.

### Simulation Tests

In 2009 a larger coalition was formed to continue the work on the NGRTC. The Advanced Tank Car Collaborative Research Program (ATCCRP) includes AAR, RSI, the American Chemistry Council, the Fertilizer Institute, and the Chlorine Institute—repre-

senting private-sector stakeholders—and U.S. DOT, the U.S. Transportation Security Administration, and Transport Canada.

Informed by the extensive safety data and by the results of the physical testing and modeling research, the ATCCRP partners developed an extensive list of potential projects. The first two were (a) to identify the most appropriate failure criteria in modeling the performance of tank steels, as well as the material properties to support accurate use of those criteria, and (b) to simulate a variety of scenarios for tank head and shell impacts, to estimate how much energy each tank design could absorb.

Both projects aimed to improve assessments of the relative performance of tank car designs by improving the accuracy of the models in the finite element software, providing greater fidelity in predicting the failure process. For each type of tank steel, the most appropriate failure criteria—that is, the set of assumptions about how that material's failure will unfold at the microstructural level—were identified for use in larger impact scenarios.

The tank impact simulation project sought to refine the design of physical tests for developing a performance standard and to understand the forces acting on a tank in an accident. Many interesting findings emerged. For example, the size and shape of the impacting object in the tests started out as a major topic of debate, but the simulations made clear that larger impactors—including those with irregular shapes and angles—were essentially equivalent to smaller, sharper impactors in this context (Figure 6, at left). The element of a large impactor that makes initial contact with the tank acts like a small, sharp impactor, doing much of its damage quickly.

### Follow-Up Projects

Several follow-up projects are now under way to

- ◆ Derive up-to-date, empirical estimates from the RSI-AAR Safety Project and FRA databases for the probability that a derailed car will lose some or all of its contents or lading and through which components;
- ◆ Simulate the performance of tank protection systems fabricated from composite materials and compare the results with those for different types of steel;
- ◆ Develop mathematical relationships between the empirical lading-loss probabilities and the estimated energy absorption results from tests and simulations;
- ◆ Develop testing protocols to determine whether a new design meets specified performance criteria; and
- ◆ Evaluate new protective design systems, including additional layers of protective material surrounding the tank.

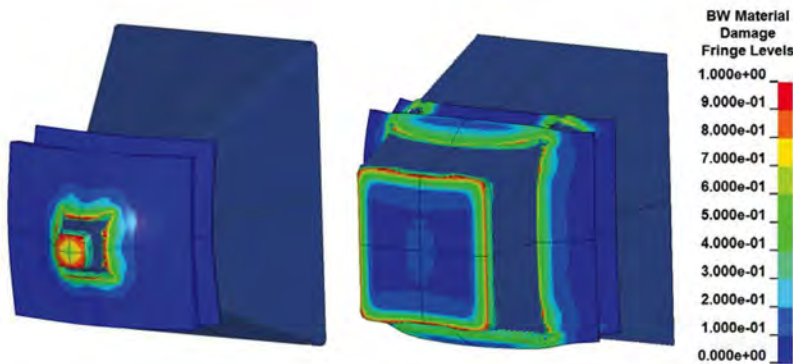

(a)

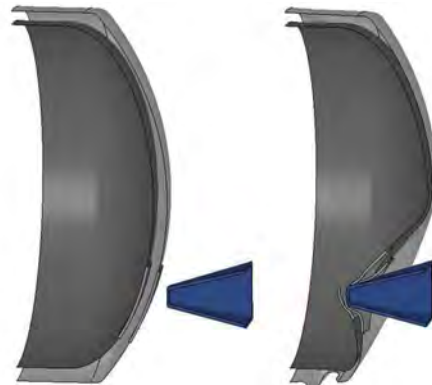

(b)

**FIGURE 6** The effect of different sizes and shapes of impactors was modeled to understand the relationship between failure mode and the geometry of objects that might strike a tank car in an accident: (a) calculated puncture behaviors with a 3-by-3-inch and a 12-by-12-inch impactor; and (b) initial impact conditions (left) and puncture response of the head (7).



Several “Tank Cars of Tomorrow” were constructed in 2012 applying findings from the Next-Generation Rail Tank Car project; the tank cars are undergoing field tests.

The findings from these research projects may be used to design and build a prototype for a new generation of tank cars for TIH materials, with a much-improved accident performance. The lessons learned also can be applied to tank cars transporting other hazardous materials. As these new design concepts are developed, tested, and perfected for implementation, the optimization techniques can help decide which combinations will offer the most effective design for tank car safety.

### Impressive Advances

In 2012 the accident rate for mainline freight trains reached an all-time low. Although technical challenges remain, the vision is that when the new tank car design concepts now under development are implemented, further significant improvements will be possible.

Working together for more than a century, industry and government have conducted research and development that has generated impressive advances in tank car safety. These advances have served the public interest by making the transportation of hazardous materials safer.

### Dedication

The authors dedicate this article to the memory of the late William J. Harris, Jr., who played a critical role in establishing the modern era of cooperative tank car safety research. Harris was a leader in the formation of the Railroad Tank Car Safety Research and Test Project of the Railway Progress Institute and the Association of American Railroads. Much of the progress in tank car safety improvements in the past four decades can be attributed to his visionary leadership.

### References

1. Heller, F. J. Evolution of Tank Car Design Through Engineering, *Proceedings of the 1970 Annual ASME Petroleum Conference*, Denver, Colorado, 1970.
2. Rader, J. H. *A Standard of Government Responsibility: Overseeing the Tank Car Committee*. Unpublished report. Federal Railroad Administration, Washington, D.C., July 2000.
3. Treichel, T. T., J. P. Hughes, C. P. L. Barkan, R. D. Sims, E. A. Philips, and M. R. Saat. *Safety Performance of Tank Cars in Accidents: Probability of Lading Loss*, RSI-AAR Railroad Tank Car Safety Research and Test Project, Association of American Railroads, Washington, D.C., 2006.
4. Saat, M. R., and C. P. L. Barkan. Generalized Railway Tank Car Safety Design Optimization for Hazardous Materials Transport: Addressing the Trade-Off Between Transportation Efficiency and Safety. *Journal of Hazardous Materials*, Vol. 189, pp. 62–68, 2011.
5. Barkan, C. P. L. Improving the Design of Higher-Capacity Railway Tank Cars for Hazardous Materials Transport: Optimizing the Trade-Off Between Weight and Safety. *Journal of Hazardous Materials* Vol. 160, pp. 122–134, 2008.
6. Jeong, D. Y., Y. H. Tang, H. Yu, M. L. Lyons, J. E. Gordon, O. Orringer and A. B. Perlman. *Engineering Studies on Structural Integrity of Railroad Tank Cars Under Accident Loading Conditions*. Final Report, DOT/FRA/ORD-09/18. Federal Railroad Administration, Washington, D.C., October 2009.
7. Kirkpatrick, S. W. *Detailed Puncture Analyses of Various Tank Car Designs*. Final Report—Revision 1, Applied Research Associates, Inc., Mountain View, California, 2010.
8. Carolan, M. E., D. Y. Jeong, A. B. Perlman, Y. H. Tang, and F. González, III. Deformation Behavior of Welded Steel Sandwich Panels Under Quasi-Static Loading. *Proceedings of the ASME/ASCE/IEEE/AREMA/TRB/INFORMS 2011 Joint Rail Conference*, Pueblo, Colorado, March 16–18, 2011.
9. Trent, R., A. Prabhakaran, D. Brabb, and V. Sharma. *Survivability of Railroad Tank Car Top Fittings in Rollover Scenario Derailments—Phase 2*. Final Report, DOT/FRA/ORD-09/20. Federal Railroad Administration, October 2009.

# Transporting Hazardous Materials by Rail

## Identifying Feasible, Lower-Risk Routes

DAVID HUNT, DAVID FRIEDMAN, MARK MEKTON, AND CARL VAN DYKE

More than 5 percent of the carloads traveling by rail in the United States contain hazardous materials, including approximately 75,000 carloads of toxic inhalation hazards (TIH) per year (1). Federal regulations enacted in 2008 specify that railroads must determine the routings for TIHs, as well as for certain classes of explosives and high-level radioactive materials (2). These regulations require the generation of alternative routes, which are subjected to a risk assessment that considers the potential impacts on the population, the environment, landmarks, and rail operations from an accident or an act of terrorism. Any deviation from the minimum-risk route requires justification—therefore a key challenge is to generate routes that are cost-effective, operationally feasible, and sufficiently diverse to provide substantial alternatives.

The regulations have spurred the development of a complex, interrelated suite of software tools incorporating a *k*-alternate path algorithm, risk assessment modeling, and data archiving.

### Generating Alternative Routes

To comply with the federal regulations, railroads must generate and evaluate a set of routes for shipping hazardous materials. The routes must be operationally feasible and must take into account the existing or planned trains operated by the railroad. Simply selecting the shortest path as an alternative route for hazmat-loaded rail-

cars would likely be infeasible from a rail operations viewpoint and would yield an assessment of unacceptable risk.

All large railroads plan their operations with specialized software tools. Several apply MultiRail, developed by Oliver Wyman, to develop the blocking plans, the train schedules, and the corresponding trip plans for moving shipments through the rail network.<sup>a</sup> Working with the railroads, Oliver Wyman extended MultiRail to include a *k*-alternate path algorithm for routing hazmat shipments. The algorithm generates

- ◆ The current railroad-operated route for the hazmat traffic and
- ◆ A set of *k*-alternate paths—the user defines the number represented by *k*—based on the existing blocking plan and train schedules, ensuring that each alternative is a feasible route.

The routes generated are distinct and move through different corridors wherever possible. Planners are able to examine the routes graphically (see Figure A, page 21) and to compare key statistics such as distance, handlings, and geographic diversity.

The planner selects routes for further examination and then begins a risk assessment with the Rail Corridor Risk Management System (RCRMS).<sup>b</sup>

### Risk Scoring

The RCRMS is a web-based software tool developed through the Railroad Research Foundation, with initial funding from the U.S. Department of Homeland Security–Federal Emergency Management Agency and CSX, and subsequent funding from the Federal Railroad Administration (FRA) and the rail industry.

Railroads submit the planned route and a set of feasible alternative routes to the RCRMS, which contains the necessary databases and risk models to evaluate each route in terms of 27 federally specified factors, including traffic volume and density; trip length; track type, grade, and

<sup>a</sup> <http://rail.railplanning.com/multi-rail/>.

<sup>b</sup> [www.railroadresearch.org/security](http://www.railroadresearch.org/security).

*The authors are with Oliver Wyman, Princeton, New Jersey: Hunt is Senior Specialist, Friedman is Senior Manager of Operations, Mekton is Vice President, and Van Dyke is Partner.*



PHOTO: NATIONAL TRANSPORTATION SAFETY BOARD

National Transportation Safety Board personnel investigate a rail crash involving hazardous materials in Paulsboro, New Jersey. Federal regulations require that railroads must determine—and obtain approval for—the routings for hazardous materials.



**FIGURE A** Illustrative example of four alternate routes for a hazardous material shipment. Each route (shown in a different color) is submitted to the RCRMS for a risk score. (NOTE: The illustration overlays hazardous material routes for a U.S. Class I railroad onto a Google map of Brazil to avoid security issues. The RCRMS is a U.S.-based risk model.)

curvature; proximity to iconic targets; population density; environmentally sensitive areas; emergency response capability along the route; passenger trains; past incidents; and impact on rail network congestion (2).

The RCRMS returns a score that incorporates the risk factors that have been quantified by the model, along with information on the risk factors that have not been quantified.<sup>c</sup> The risk scores and information output by the RCRMS allow rail planners to develop comprehensive risk profiles for each potential route.

### Archiving Historical Routes

The planner selects a final route for the hazmat shipment using the risk rankings from the RCRMS and the operating statistics from MultiRail. To comply with potential FRA audits, the railroads must document why each route was selected. To comply with another requirement, MultiRail can archive the precise route for every hazmat shipment so that the information can be provided quickly to FRA on request.

Through evolving technology solutions and advanced risk modeling, railroads are working to provide safe, secure, and efficient transportation of hazardous materials across the country.

### References

1. *Hazmat Transportation by Rail: An Unfair Liability*. Association of American Railroads, Washington, D.C., March 2011.
2. *Federal Register*, Vol. 73, No. 229, November 26, 2008, pp. 72182–72194.

<sup>c</sup> Of the 27 factors, 12 are not currently quantified; efforts are under way to quantify 7 of the 12.



PHOTO: JOHN PHELAN

To avoid environmentally sensitive areas, proposed hazmat routes must be evaluated according to federal standards; sensitive environmental resources along the Fall River Line in Massachusetts include the Freetown–Fall River State Forest, priority habitats of state-listed rare species, vernal pools, and wetlands.

Acela Express on the  
Northeast Corridor.



PHOTO: VOLPE CENTER

**Railroads and  
Research**  
Sharing Track

# Gaining Track Support to Improve Track Safety, Efficiency, and the Competitiveness of the Rail Industry

TED SUSSMANN, DAVID READ, JOHN CHOROS, AND SHANE M. FARRITOR

Sussmann is Civil Engineer and Choros is Mechanical Engineer, Volpe National Transportation Systems Center, Cambridge, Massachusetts. Read is Principal Investigator (retired), Transportation Technology Center, Inc., Pueblo, Colorado. Farritor is Professor, Mechanical and Materials Engineering, University of Nebraska, Lincoln.

**R**ailway track innovations historically have focused on track structure support. Although track structure is simple, improving the performance and interaction of the components under passing trains is a challenge.

From development of new rail sections to improving the tie and fastening systems, technological advances have made rail competitive as a transportation mode. Advances in track support and measurement systems are ensuring a more efficient and safe performance from the track structure. Structural measures evaluate the geometric smoothness and condition of track and provide the data for assessing track performance.

The efficiency of track structure increases with

structural reliability brought about by improved components and by diagnostic tools that can identify zones of increased failure risk. These tools, along with methods to improve track stability, are critical to the competitiveness of the U.S. rail industry.

Track diagnostic tools provide assessments of the most common failure modes. Each tool has developed from an accident that exposed a particular vulnerability of the track structure, indicated in the statistics of the Federal Railroad Administration's (FRA's) Railway Accident–Incident Reporting System.

Track components have been hardened and strengthened to improve durability and performance, but increases in train loads and speeds, coupled with

recent extreme weather events, have necessitated constant vigilance for track safety. Reducing the stresses by ensuring proper performance of the track structure is a key endeavor. Track structure diagnostic tools can ensure that the track structure is working to reduce the stress on individual components and can help avoid the stresses associated with the deterioration of local track support.

### Safe, Efficient Infrastructure

Safety and efficiency are often competing goals—safety requires good track performance, but efficiency requires low-cost track maintenance and construction. The two goals must be addressed together successfully and positively to ensure industry competitiveness. The rail industry has accomplished this—rail is the leading transportation mode in terms of safety and efficiency.

The industry has developed and implemented technologies for safe operations, but at low initial cost in response to pressure from competitors and investors. Figure 1 (below) illustrates safety trends. Periodically the industry has applied a long-term perspective to the goal of keeping costs low and has built infrastructure that will last, realizing that the cost of replacement would be prohibitive.

The service life of railway track varies; many lines have served for more than 100 years. The service life of track components, however, generally extends into tens of years. An increase in component life, therefore, will yield an economic benefit.

An economic analysis of the life cycle of track infrastructure should consider a period of more than the typical 20 years and take into account the vari-



PHOTO: METROPOLITAN TRANSPORTATION AUTHORITY

ability of service life among components. This type of analysis places a premium on maintenance throughout the service life. The economic goal should be a predictable track life cycle in which no single component fails or compromises the integrity of the whole.

### Performance Characteristics

One of the challenges facing the industry is the initial capital investment, which involves justifying the increased initial costs to reduce life-cycle costs. Therefore a premium, next-generation track structure is likeliest in a passenger corridor with strong ridership and a tight operating schedule (1). Except in California, most planned U.S. passenger projects will be incremental—new service will be established,

Workers from New York’s Metropolitan Transportation Authority repair damage to Metro-North’s Hudson Line after Superstorm Sandy in 2012. Extreme weather and increases in train loads and speeds require constant attention to track safety.

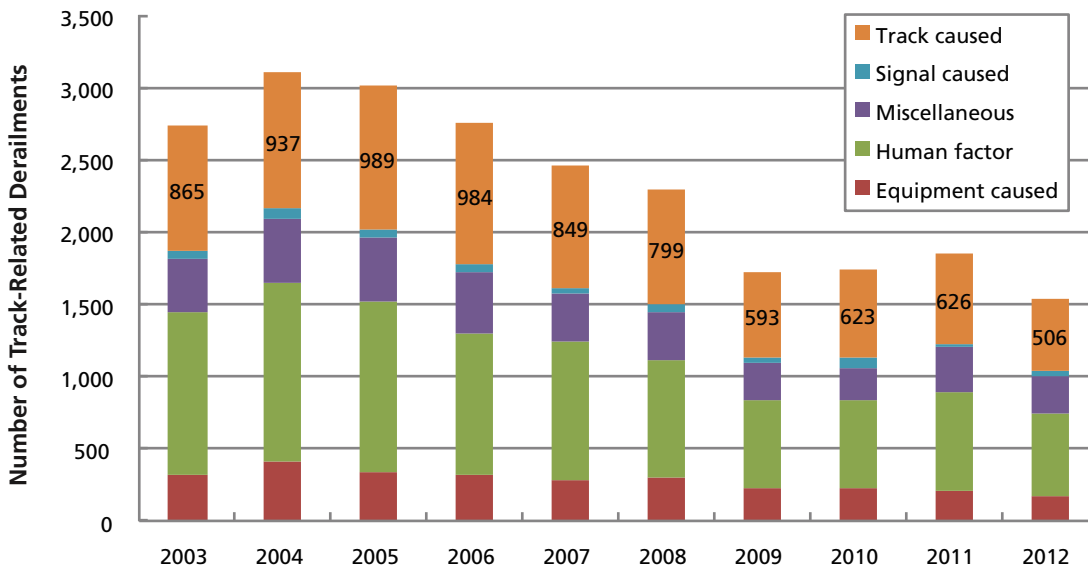

**FIGURE 1** Track safety trends for the past 10 years show decreases in track-related derailments, which nevertheless constitute 32 percent of rail accidents.





Transition from slab track to ballasted track at demonstration test, Transportation Technology Center, Inc.

and existing service will be improved, while major infrastructure additions are undertaken.

Premium track designs—for example, direct fixation concrete slab track instead of ballast (see photograph, above)—may be used in critical locations, such as urban corridors, for which the primary concern is service reliability, as in large portions of the Japanese high-speed rail network. France’s high-speed rail network, in contrast, has relied on ballasted track (2), which is common on corridors with speeds and traffic volumes similar to those of the emerging and high-speed corridors in the United States.

Required performance characteristics for high-performance ballasted track are as follows:

1. Premium track components;
2. Good track support;
3. Open, maintainable track structure;
4. Realignment, repair, and maintenance flexibility; and
5. Surveys of the track location.

High-speed rail in France—a system that shares features with high-speed rail in the United States—uses high-performance ballasted track.



PHOTO: RAIL EUROPE

Track constructed with these characteristics must be monitored periodically to assess condition, to plan maintenance, and to evaluate safety. The inspections should apply measures of track structural condition to identify any variations from the design at an early stage, ensuring the effectiveness of repairs in achieving the desired long-term performance.

## Structural Assessment

A structural assessment measures engineering properties or physical characteristics to assess the stability and durability of the track. Track geometry inspections, in contrast, focus on smoothness for ride quality and on vehicle derailment risk. A trend of deterioration in track geometry may indicate compromised structural integrity, but additional, appropriate data are needed to diagnose the cause or to evaluate track load capacity or expected service life. A structural assessment of track applies parameters directly linked to failure mechanisms; it detects emerging structural problems, evaluates stability and durability, and enables timely repairs.

**TABLE 1 Track Structural Parameters and Failure Mechanisms**

| Parameter                | Failure Mechanism                    |
|--------------------------|--------------------------------------|
| Lateral track strength   | Track buckle                         |
| Rail neutral temperature | Rail pull-apart, track buckle        |
| Gage restraint           | Wide gage, wheel drop, rail rollover |
| Ballast condition        | Track instability, geometry fault    |
| Track deflection         | Track load capacity, settlement      |

The parameters for track structural assessment are linked to specific failure mechanisms and the associated failure risks, as shown in Table 1 (above). A derailment caused by track buckle or misalignment will damage cars, equipment, and track extensively, but a wide-gage track geometry—when rails are spread wider apart, so that the wheelsets drop between the rails—may be less destructive and may cause less potential harm. The failure mechanisms listed in the table either have a high likelihood of occurrence—such as wide gage—or have the potential to be particularly destructive—such as track buckle—and sometimes both.

### Lateral Track Support

Lateral track strength is the resistance of track to lateral movement. Passing traffic or built-up stress in the rail generates lateral loads, which tend to deform the track. Lateral track strength measurement

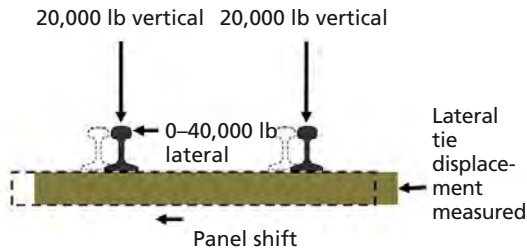

**FIGURE 2** Lateral track strength measurement.

addresses tie displacement under a lateral force applied by a constant vertical load, as illustrated in Figure 2 (above). Lateral resistance can be evaluated with stationary tests or with moving loads, such as the Association of American Railroads' track loading vehicle (TLV) (2, 3).

Lateral track strength decreases substantially after tamping—a maintenance activity that raises the ballast layer to correct the track profile; tamping presents a particular risk to lateral track deformation until the track is stabilized, as illustrated in Figure 3 (below) (2).

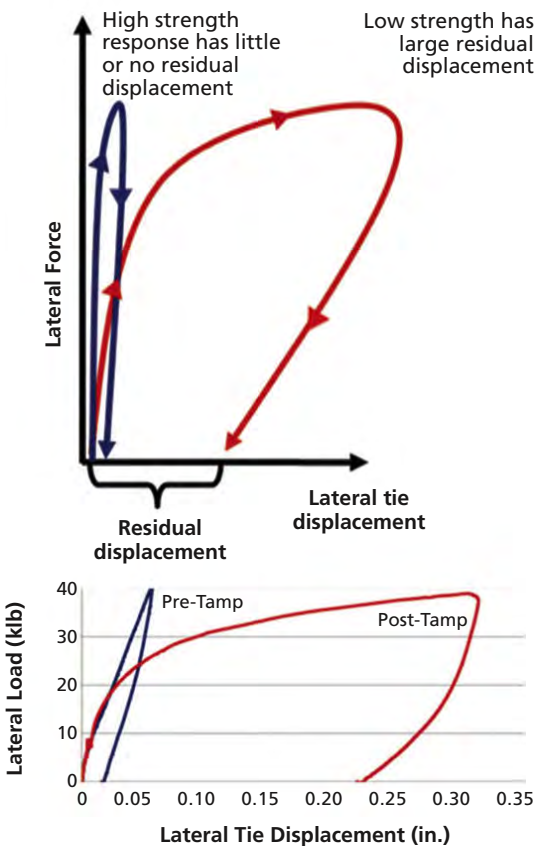

**FIGURE 3** Lateral track strength data recorded by a track-loading vehicle before and after track tamping.



### Longitudinal Stability

Longitudinal rail movement changes both the rail stress condition and the temperature, increasing the risk that the track will buckle (3) or pull apart. The track lateral resistance must be high enough to avoid buckling; again, tamping may present a risk of buckling until the track is stabilized.

New rail stress measures are in development to address the effect of rail movement through the fastener, as well as to evaluate the track position, both of which are challenging tasks. Various rail compression or tension measurements have emerged and have been used in assessing rail stress, including the Vortok Verse and a noncontact, ultrasonic device pioneered by the University of California, San Diego, under the sponsorship of FRA.

### Gage Widening

Track gage strength is measured by applying a lateral load to both rails under a constant vertical load and then measuring the deflection. The strength is assessed based on the difference in track gage before and at the load application; the difference is known



Association of American Railroads' track-loading vehicle.

Testing of University of California–San Diego's rail neutral temperature measurement device on continuous welded rail with concrete ties at Transportation Technology Center, Inc. Note the strain gauge on each side for validation and comparison.



FRA DOTX-218 gage restraint measurement system with University of Nebraska–Lincoln’s track deflection system.

as delta gage. Rail-bound vehicles that operate only on track and high-rail vehicles that can operate on road and track have been developed to measure gage strength (4); examples include the TLV, the FRA DOTX-218 gage restraint measurement system, and the Holland Track Star.

### Ballast Condition

Ballast is the track’s foundation, and the ballast condition affects long-term performance of the track; any settlement-related degradation of performance will cause stress on track components and rolling stock. As track degrades, ballast wear under load or from contamination with material blown in or spilled from passing trains can cause ballast fouling, which can increase the rate of deterioration (5).

Track inspections can detect ballast fouling with ground-penetrating radar (GPR), a nondestructive technology that pulses electromagnetic energy into the ground to develop an image of the subsurface (6, 7), as shown in Figure 4 (below, left). Although the measurement of fouling has been a challenge with GPR, methods have developed to analyze the difference in signal response between clean ballast and highly fouled ballast and to correlate the result with accepted measures of fouling condition (8, 9). GPR also may assist in measuring the layer thickness, profile, moisture content, and drainage of track substructure and may detect buried objects.

### Track Deflection

Track support is critical to track performance. The best measure of track support is the vertical track stiffness, analyzed with the track vertical load-deflection curve slope (9), as illustrated in Figure 5 (right). Most important are the slope associated with the seating deflection, which indicates gaps of slack between track components, and the slope associated with the contact deflection, which indicates the load-deflection response of the track when all elements are engaged. The contact deflection is associated with variations in subgrade stiffness, track superstructure, and the shallow substructure.

Challenges to measuring the full load-deflection curve have led to the development of a system by the University of Nebraska–Lincoln to survey the track for locations of excessive track deflection (10). A

beam mounted to the side frame of a truck measures the relative position of the wheel–rail contact and a reference point on the rail 4 feet away. A high reading indicates a large deflection, which implies track support problems.

Measuring deflection will become increasingly important for maintenance planning, because excessive deflection increases stress in the rail, decreasing service life (11, 12). Comprehensive testing of the curve slope and of the measuring system developed by the University of Nebraska–Lincoln has shown that deflection measurements complement other track measurements.

## High Expectations

The rail industry anticipates growth in intermodal traffic, both domestic and international, as public entities and trucking companies turn to the railroads to help solve problems of highway congestion, escalating fuel prices, and driver shortages. Challenges include issues associated with an aging infrastructure and an aging workforce, along with a constant pressure to maintain leadership in terms of safety and efficiency. The pressure to do more with fewer resources and less staff has never been greater.

Track structural assessment and inspection tools present unique opportunities to respond to these challenges. By providing timely and accurate safety inspections, by guiding maintenance, and by ensuring efficient use of resources, these technologies can advance the efficiency and safety goals of the industry. In addition, these technologies can assist in evaluating compliance with construction specifications, so that new rail infrastructure can offer higher levels of quality and uniformity.

The vibrant history of railway track research and development has introduced many technologies that have spurred further understanding of track behavior and quality. Industry has applied these advances to the training of inspectors and workmen in the finer points of track behavior and inspection.

These efforts have produced high expectations

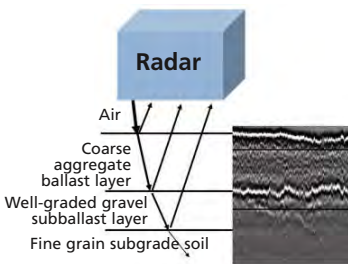

FIGURE 4 Ground-penetrating radar signal generation in response to track substructure boundaries.

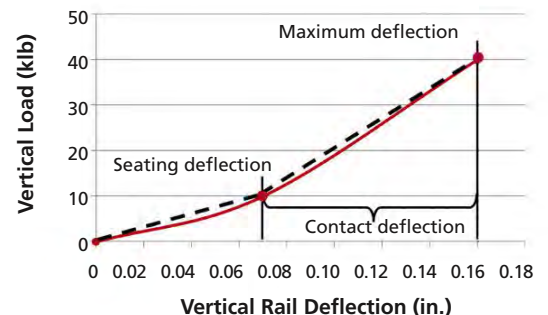

FIGURE 5 Track vertical load-deflection curve slope.



State-of-the-art track assessment vehicles near Cheyenne, Wyoming: Union Pacific EC-4 evaluation car and FRA DOTX-218 gage restraint measurement system in consist with University of Nebraska-Lincoln track deflection system.

for industry safety and efficiency. Continuing this trend will require research targeted at persistent and unrelenting safety risks. Building higher-quality infrastructure and using structural inspection tools to monitor deterioration will ensure that the industry can meet the ever-increasing safety and cost efficiency expectations of modern railway track.

## References

1. Li, D., Bilow, D., and T. R. Sussmann. Slab Track for Shared Freight and High-Speed Passenger Service. *Proceedings of the 2010 Joint Rail Conference on High-Speed and Intercity Rail*, Urbana, Illinois, April 2010.
2. Esveld, C. Recent Developments in High-Speed Track. *Proceedings of the First International Conference on Road and Rail Infrastructure*, Opatija, Croatia. May 17–18, 2010.
3. Sussmann, T. R., A. Kish, and M. J. Trosino. Investigation of the Influence of Track Maintenance on the Lateral Resistance of Concrete Tie Track. In *Transportation Research Record: Journal of the Transportation Research Board*, No. 1825, Transportation Research Board of the National Academies, Washington, D.C., 2003, pp. 56–63.
4. Li, D., R. Thompson, P. Marquez, and S. Kalay. Development and Implementation of a Continuous Track-Support Testing Technique. In *Transportation Research Record: Journal of the Transportation Research Board*, No. 1863, Transportation Research Board of the National Academies, Washington, D.C., 2004, pp. 68–73.
5. Sussmann, T. R., M. Ruel, and S. Chrismer. Source of Ballast Fouling and Influence Considerations for Condition Assessment Criteria. In *Transportation Research Record: Journal of the Transportation Research Board*, No. 2289, Transportation Research Board of the National Academies, Washington, D.C., 2012, pp. 87–94.
6. Choros, J., T. R. Sussmann, M. Fateh, and E. Curtis. *Gage Restraint Measurement System Comparison Tests: Railbound and Hi-Rail Vehicles*. Report No. DOT/FRA/ORD/03/29. Federal Railroad Administration, 2003.
7. Roberts, R., I. Al-Qadi, E. Tutumluer, J. Boyle, and T. Sussmann. Advances in Railroad Ballast Evaluation Using 2 GHz Horn Antennas. Presented at 11th International Conference on Ground-Penetrating Radar, Columbus, Ohio, 2006.
8. Roberts, R., I. Al-Qadi, E. Tutumluer, and J. Boyle. *Subsurface Evaluation of Railway Track Using Ground-Penetrating Radar*. Report No. FRA/ORD-09/08. Federal Railroad Administration, 2008.
9. Silvast, M., M. Levomaki, A. Nurmikolu, and J. Noukka. NDT Techniques in Railway Structure Analysis. Presented at 7th World Congress on Railway Research, Montreal, Canada, June 2006.
10. Sussmann, T. R., W. E. Ebersohn, and E. T. Selig. Fundamental Nonlinear Track Load-Deflection Behavior for Con-

dition Evaluation, In *Transportation Research Record: Journal of the Transportation Research Board*, No. 1742, TRB, National Research Council, Washington, D.C., 2001, pp. 61–67.

11. Farritor, S. *Real-Time Measurement of Track Modulus from a Moving Car*. Report No. FRA/ORD-05/05. Federal Railroad Administration, December 2005.
12. Greisen, C., S. Lu, H. Duan, S. Farritor, R. Arnold, T. Sussmann, W. GeMeiner, D. Clark, T. Toth, K. Hicks, M. Fateh, and G. Carr. Estimation of Rail Stress from Real-Time Vertical Track Deflection Measurement. Presented at American Society of Mechanical Engineers Joint Rail Conference, Pueblo, Colorado, March 2009.

## IDEA Programs Seek Proposals for Railroad Safety

The Transportation Research Board (TRB) is accepting proposals for projects to develop and test innovative methods to improve railroad safety or performance through the Safety Innovations Deserving Exploratory Analysis (IDEA) Program. Proposals should seek to develop or test promising but unproved innovations to advance railroad practice and can be applicable to any type of railroad, including high-speed rail, intercity passenger rail, or freight railroads.

Proposals are due September 16, 2013. The Federal Railroad Administration (FRA) funds the Safety IDEA program, which is managed by TRB.

For instructions on preparing and submitting IDEA proposals, see the IDEA Program Announcement on the IDEA website, [www.TRB.org/IDEA](http://www.TRB.org/IDEA). Proposals are eligible for up to \$100,000 in IDEA funds. Address questions to Jon Williams, [jwilliams@nas.edu](mailto:jwilliams@nas.edu), 202-334-3245.



Installation of an IDEA project at the Transportation Technology Center, Inc., to detect railroad car truck hunting, or swaying.



Many improvements in rail safety over the past century— such as warning lights and safer work practices—resulted from new technological and procedural approaches.

Photo: Greg Bator

**Railroads and Research**  
Sharing Track

# Evaluations of Demonstration Pilots Produce Change

Fourteen Years of Safety-Culture Improvement Efforts by the Federal Railroad Administration

JOYCE M. RANNEY, MICHAEL K. ZUSCHLAG, JONATHAN MORELL, MICHAEL K. COPLEN, JORDAN MULTER, AND THOMAS G. RASLEAR

*Ranney is Senior Program Manager, Zuschlag is Engineering Psychologist, and Multer is Rail Program Manager, Volpe National Transportation Systems Center, Cambridge, Massachusetts. Morell is Director of Evaluation, Fulcrum Corporation, Reston, Virginia. Coplen is Senior Evaluator and Manager, Safety and Culture Performance Program, and Raslear is Chief, Human Factors Research Division, Office of Research and Development, Federal Railroad Administration, Washington, D.C.*

**R**ailroading began in the 1830s with the invention of the steam engine. Reflecting the military backgrounds of its early managers, the industry adopted a command-and-control style that relied on punishment and discipline to maintain smooth operations. The style, however, also fit an enterprise that needed tight control to prevent widespread disruptions and uncertain operating conditions. The result was a reactive management style and adversarial relations between labor and management.

U.S. Army railroad operations in northern Virginia during the Civil War. The military backgrounds of the rail industry's early managers set the tone for employee relations.

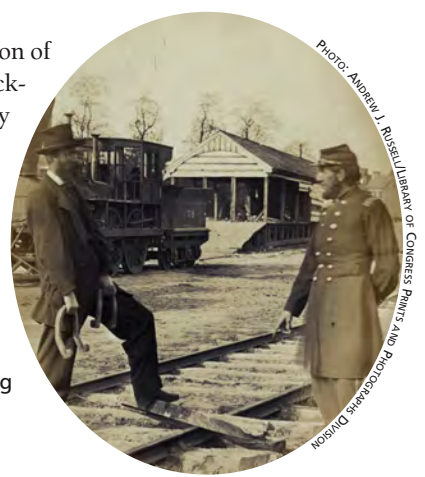

Photo: Andrew J. Russett, Library of Congress Prints and Photographs Division

The industry was so dangerous that a workman's compensation model of support for injured employees was not viable; between 1888 and 1894, for example, more than 16,000 fatalities were associated with the joining or coupling of cars. The Federal Employers' Liability Act (FELA) of 1908 based compensation on the allocation of relative fault determined through legal proceedings.

This history prevented a culture of information-sharing and problem solving. No framework arose for understanding why railroad accidents occurred. Instead, simplistic, superficial explanations prevailed; today's view is that accident causes are rooted in systems—a complex of technology, business, human behavior, process, and operating environments (1). The railroad industry was not set up to be responsive to system-based safety approaches to minimizing risk.

As a result, the industry relied on technological and procedural approaches. Technological approaches deal with work-environment design, such as signals or personal protection equipment; procedural approaches address work practices, such as rules for sounding a horn when approaching a crossing.

These targeted approaches have proved successful—in the past 40 years, accidents have decreased and have remained at low levels. The same statistics, however, also indicate that technology and procedure approaches, considered individually, are limited in their ability to continue to improve safety. Analyzed in terms of employee hours and of train miles, the trends in accident reduction have slowed considerably since 1985 (2).

A combination of business conditions, federal policy, labor-management relations, accident statistics, evolving opinion, and research on the causes of accidents encouraged the Federal Railroad Administration (FRA), management, and labor to experiment with system-based safety culture interventions.

## Safety Culture Approaches

To address the slow progress in reducing accidents, the FRA Office of Research and Development (ORD) implemented an evaluation program from 1998 to 2012 to identify and test system-based safety culture interventions: what would work and why, what benefits could be expected, and how those innovations could be maintained. The evaluation program produced four approaches to system-based safety culture change:

- ◆ Participative Safety Rules Revision,
- ◆ Investigation of Safety-Related Occurrences Protocol (ISROP),
- ◆ Clear Signal for Action (CSA), and



PHOTO: HARLAN HOUFFER/LIBRARY OF CONGRESS PRINTS AND PHOTOGRAPHS DIVISION

### ◆ The Confidential Close-Call Reporting System (C<sup>3</sup>RS).

FRA was a major driver of CSA and C<sup>3</sup>RS; the railroad industry initiated Participative Safety Rules Revision and ISROP. ORD evaluated the programs and analyzed what enhanced and what limited the success.

The programs encompassed six aspects of system-based safety approaches:

- ◆ Risk identification,
- ◆ Collaborative problem-solving,
- ◆ Root-cause determination,
- ◆ Peer-to-peer coaching and feedback,
- ◆ Implementation of corrective actions, and
- ◆ A mechanism by which dangerous and sensitive conditions could be openly discussed without fear of retribution.

In ISROP and C<sup>3</sup>RS, the dominant themes were collective root-cause problem solving and implementation of corrective actions. CSA added the unique element of peer-to-peer coaching and feedback. Participative rules revision dealt exclusively with collaborative problem-solving by labor and management.

The testing and evaluations included 14 demonstration pilot sites; eight passenger and freight railroads; one barge line; and workers in the transportation, mechanical, track, signal, and passenger-service unions (Table 1, page 30). ORD's evaluation program aimed at determining whether any of these approaches would work in railroad settings.

A major wreck on the T.P. & W.R.R. near Chatsworth, Illinois, in 1887, was labeled "the most appalling railroad disaster on the Continent." In the late 19th and early 20th centuries, the rail industry was so dangerous that workman's compensation was impossible to implement.

## ORD's Program

Evaluators at FRA and the Volpe National Transportation Systems Center examined the evaluations and impacts and incorporated industry perspectives on the lessons learned from each of the demonstration pilot sites. Safety improvements were seen as the approaches were implemented.

As a result, the industry was educated on the value not only of safety culture approaches but also of independent, objective evaluations. To ensure the rigor of the evaluations, FRA recruited and assembled a group of experts with the working relationships and technical capabilities to design and execute a range of rail-related evaluation projects (3).

### Safety Rules Revision

#### Description of Approach

The many mergers in the railroad industry in the 1980s and 1990s led to a proliferation of operating rules, some overlapping and some conflicting. The rules are critical in directing safe behavior, but too many can be counterproductive, with disagreements about application and confusion about expectations.

Moreover, in the industry's fault-based liability structure, rules violations can generate tension between labor and management (4–6).

In the traditional approach to rules revision, managers write rules without labor involvement. Stakeholder involvement, however, is a key element and strategy for evaluation; FRA therefore was interested in demonstrations that involved a joint effort of labor and management. Initially, the evaluations addressed four questions:

- ◆ Which rules should remain?
- ◆ Which rules should cover all employees and which should be craft-specific?
- ◆ What wording would make the new rules observable and enforceable?
- ◆ What wording would ensure that a rule is unambiguous and describes the *only* proper way to perform a work activity?

Actively involving labor, with the support of management, is meant to generate labor's ownership of the rules, encouraging compliance, improving the

**TABLE 1 Chronology of ORD Pilots**

| Approach  | Carrier                            | Start Year | Population  |
|---|------------------------------------|------------|---|
| <b>Participative Safety Rules Revision</b>                          | CSX Transportation                 | 1991       | Mechanical, track, engineering, transportation, signal      |
|   | American Commercial Barge Lines*   | 1999       | All operating departments                                   |
|   | Kansas City Southern               | 2000       | Mechanical, track, engineering, transportation, signal      |
|   | Canadian National–Illinois Central | 2001       | Mechanical, track, engineering, transportation, signal      |
| <b>Root-Cause-Analysis Problem Solving</b>                          | Canadian Pacific (3 sites)         | 2003       | Three mechanical departments                                |
| <b>Clear Signal for Action (CSA)</b>                                |                                    |            |   |
| EAGLES (Employee Alliance for Great Levels of Excellence in Safety) | Amtrak                             | 2001       | Baggage, Red Caps, ticket and gate agents, customer service |
| CAB (Changing At-Risk Behavior)                                     | Union Pacific                      | 2005       | Road and yard crews   |
| STEEL (Safety Through Employees Exercising Leadership)              | Union Pacific                      | 2006       | Yard crews  |
| <b>Confidential Close-Call Reporting System (C<sup>3</sup>RS)</b>   | Union Pacific                      | 2007       | Conductors, engineers                                       |
|   | Canadian Pacific                   | 2008       | Conductors, engineers                                       |
|   | New Jersey Transit                 | 2009       | Conductors, engineers                                       |
|   | Amtrak                             | 2010       | Conductors, engineers                                       |

\* Not a railroad but a transportation carrier with workers subject to a rule structure similar to that of railroads.

labor-management relationship, and strengthening the safety culture.

The Participative Safety Rules Revision was applied in two phases. The first comprised activities that made clear management's willingness to involve labor in deciding which rules were worthy of retaining and which should be removed from the rulebook. In the second phase, labor and management collaborated to simplify and reduce the rules and to make them more objective and enforceable.

This project tested two hypotheses:

1. Labor involvement and collaboration with management would provide a better understanding of which rules could be observed and enforced and which could not, and
2. Collaboration would improve safety and safety culture.

*Methods and Findings*

The evaluation involved interviews of participants in the review and revision of the rules. The results suggested that a successful approach requires both safety leadership and collaborative problem solving by labor and management.

Respondents from carriers that used both safety leadership and participative rulemaking reported a positive shift in safety culture. The work force experienced a change in the value of rules—survey responses transitioned from “mostly not helpful” to “mostly helpful.” This is a major accomplishment—an alteration in the way that labor historically had viewed railroad industry rules.

The interviews also suggested improvements in labor-management relations and in rule compliance. The number of rules dropped significantly at all four participating transportation carriers, as shown in Table 2 (above, right).

**TABLE 2 Number of Safety Rules Before and After Revision**

| Railroad                                  | Total Rules Before | Total Rules After | Craft Rules After | Core Rules After |
|---|--------------------|-------------------|-------------------|------------------|
| <b>American Commercial Barge Lines</b>    | 400                | 125               | 101               | 24               |
| <b>Canadian National–Illinois Central</b> | 1,360              | 686               |                   |                  |
| <b>CSX Transportation</b>                 | 900                |                   |                   | 17               |
| • Transportation                          |                    | 36                | 19                |                  |
| • Mechanical                              |                    | 105               | 88                |                  |
| • Track and engineering*                  |                    | 105               | 88                |                  |
| <b>Kansas City Southern</b>               | 742                |                   |                   | 17               |
| • Transportation                          |                    | 110               | 93                |                  |
| • Mechanical                              |                    | 259               | 242               |                  |
| • Track and engineering                   |                    | 244               | 227               |                  |
| • Clerical                                |                    | 115               | 98                |                  |

\* Informed estimate; specific count not available.

An analysis of FRA incident data showed that at one railroad, the rules-revision approach resulted in a drop of approximately 30 percent in reportable injuries across all crafts. Two sites observed a decrease in liability claims. In addition, the rules revision approach added a previously unrecognized distinction between core rules and craft-specific rules.

**Root-Cause Analysis**

*Description of Approach*

Railroads were implementing different, innovative risk-management and safety culture approaches. Canadian Pacific (CP) Railroad, for example, had established a program for investigating incidents, Investigation of Safety-Related Occurrences Protocol

PHOTO: CANADIAN PACIFIC RAILROAD



Canadian Pacific Railroad allowed FRA to study its incident investigation program, which comprised safety leadership, root-cause analysis of close-call and incident investigations, corrective actions, and safety communication.



**FIGURE 1 Logic of operations and impact: Investigation of Safety-Related Occurrences Protocol (ISROP).** (Mgmt = management; H&S = health and safety)

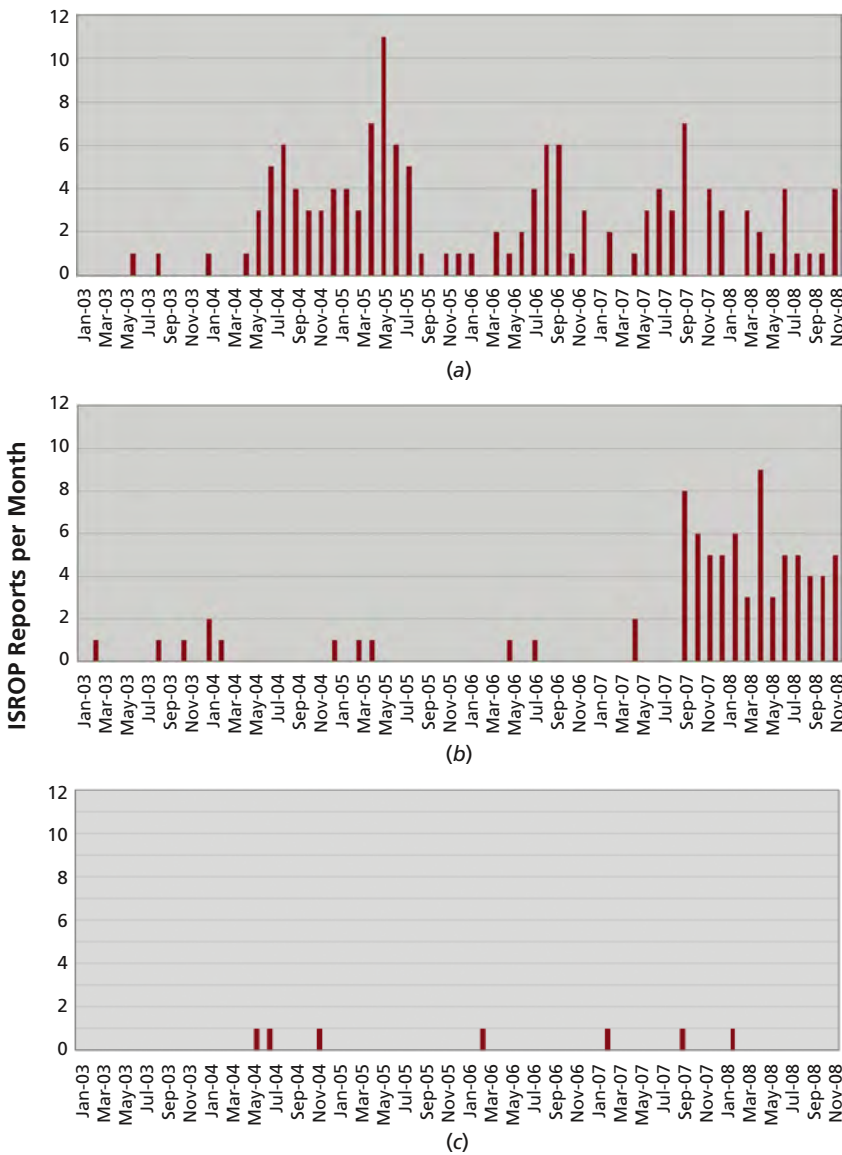
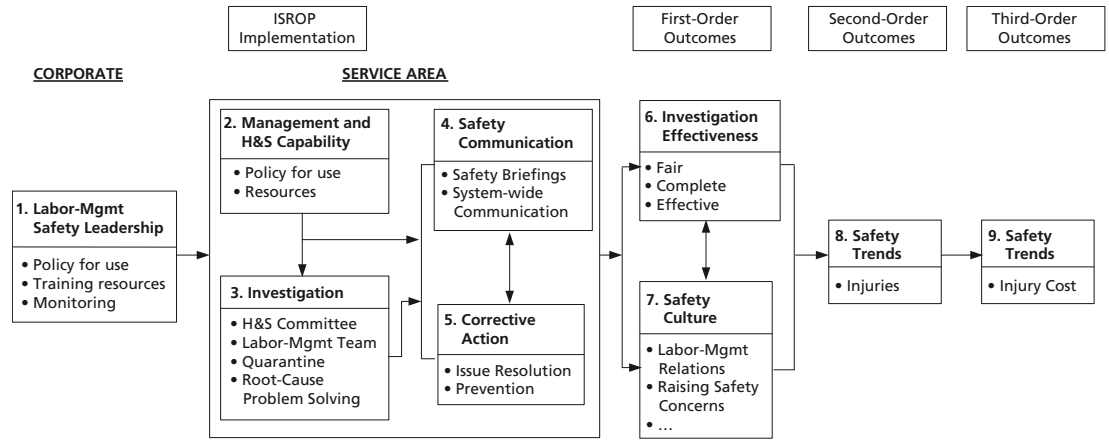

**FIGURE 2 Injury reduction related to number of investigations:** (a) Department 1: many investigations, 50 percent (significant) reduction in injury rate; (b) Department 2: later start, 43 percent (significant) reduction in injury rate; and (c) Department 3: few investigations, 4 percent reduction in injury rate.

(ISROP), which appeared to be influencing safety culture. Senior management at CP agreed to allow FRA to evaluate ISROP, which combines labor–management safety leadership, labor–management root-cause analysis of close-call and incident investigations, corrective actions, and safety communication. As the program was rolled out, senior management reviewed investigation reports to ensure that the list of contributing causes included such factors as company policy, procedures, and management practices.

FRA evaluated ISROP at three mechanical departments at three locations. One site was a high user of ISROP, one was a moderate user, and the third a low user. Figure 1 (above) depicts a model of the ISROP process (7–9).

*Methods and Findings*

Quantitative measures included the numbers of investigations and injuries, as well as the scores on a safety culture scale. Qualitative data included field notes, analysis of corrective actions, and baseline and follow-up interviews with workers and managers at the three sites.

ISROP produced many investigations and corrections of safety-related problems. Between April 2003 and January 2008, the site that used the protocol the most conducted 142 investigations; the site that used it slightly less, 114 investigations; and the site that used it the least, seven investigations. The highest-use site experienced a 50 percent decrease in injury rates; the sites that made less use of ISROP experienced correspondingly smaller changes (Figure 2, at left).

**Clear Signal for Action**

*Description of Approach*

CSA integrates three processes that have worked in other industries to improve safety:

- ◆ Peer-to-peer feedback (10, 11),

- ◆ Continuous process improvement (10–13), and
- ◆ Safety leadership (14, 15).

With strong labor–management cooperation, the three processes work together to address risks that are within workers’ control, as well as systemic issues that only management can correct. Outcomes of the process include changes in worker practices, systemic conditions, and management practices. In turn, these changes result in improvements in safety and safety culture (2, 16–21). Figure 3 (below) illustrates the CSA process.

*Methods and Findings*

Three demonstration pilot sites were evaluated. Quantitative measures included railroad safety outcomes such as injuries, locomotive engineer decertifications, derailments, and a pre- and postperception survey. Qualitative measures included interview results and analyses of project records to assess the extent of implementation.

The first demonstration focused on baggage handlers at Amtrak in Illinois and resulted in a 76 percent reduction in injuries (12). The second demonstration was with Union Pacific road crews in Texas and resulted in a 79 percent decrease in locomotive engineer decertifications—considered a proxy for collisions, because running through a red signal risks crashing into another train. The third demonstration was with Union Pacific yard crews in



PHOTO: MATT JOHNSON

Louisiana and recorded a 62 percent reduction in derailments and a resulting increase in productivity, with less time spent on repairs.

Interview and survey data suggested that safety culture improved, although the three sites varied in how effectively the local managers led the approaches. Pilot sites with strong leaders improved safety culture and had smoother implementations. The success of the pilot sites encouraged Union Pacific and Amtrak to expand CSA throughout their organizations.

A pilot demonstration of the Clear Signal for Action approach with Amtrak baggage handlers led to a 76 percent reduction in injuries.

**Close-Call Reporting System**

*Description of Approach*

C<sup>3</sup>RS sends close-call reports through a neutral third party to remove sensitive information and then

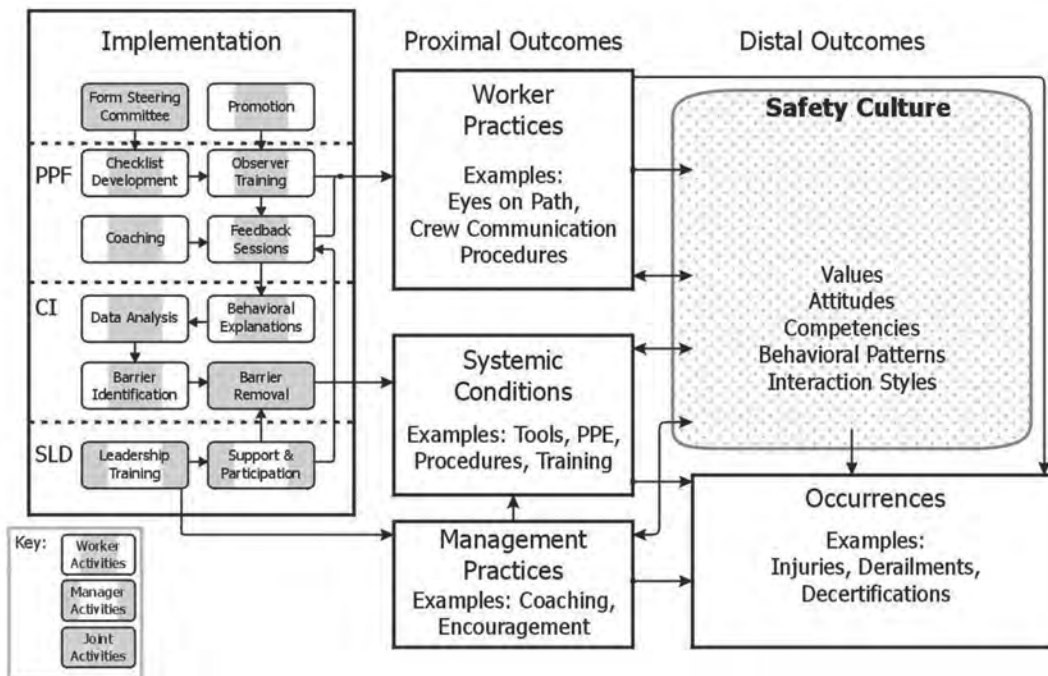

**FIGURE 3** Logic of operation and impact: Clear Signal for Action (CSA) process. (PPF = peer-to-peer feedback; CI = continuous improvement; SLD = safety leadership development; PPE = personal protective equipment.)

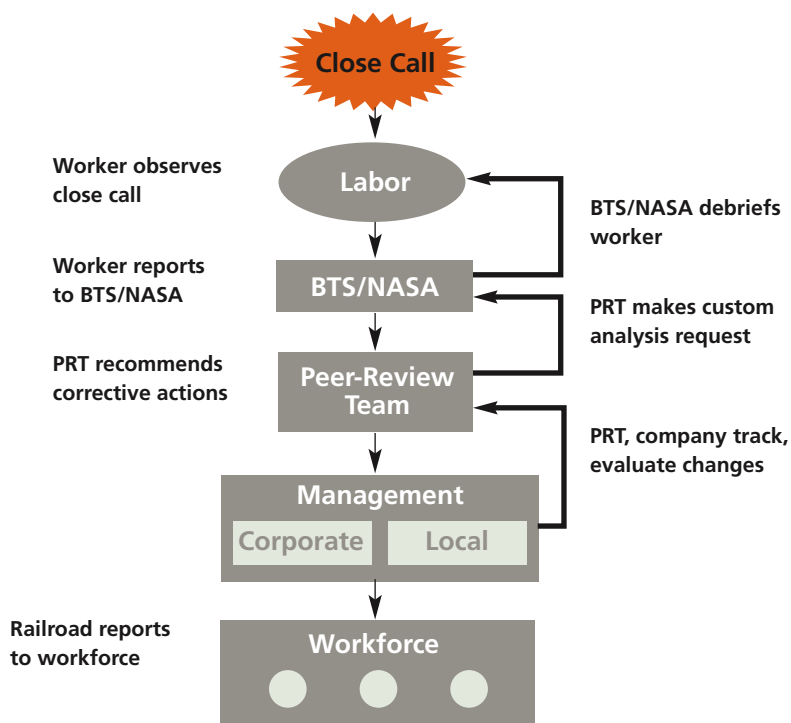
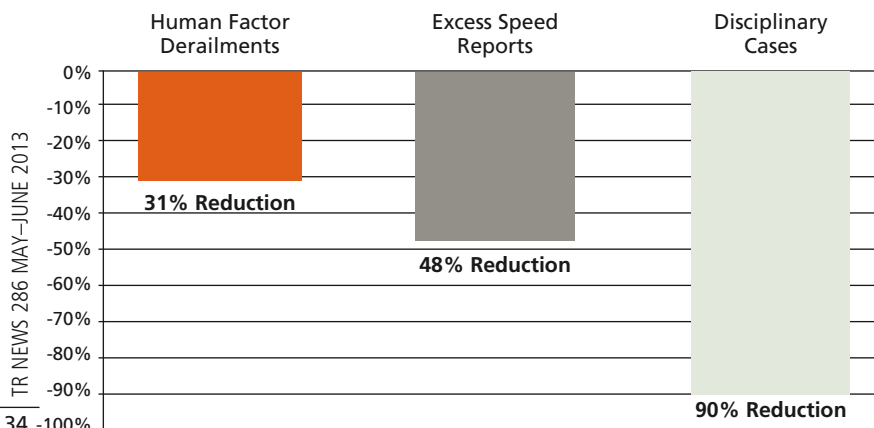

**FIGURE 4 Confidential Close-Call Reporting System (C<sup>3</sup>RS) process.** (BTS = Bureau of Transportation Statistics; NASA = National Aeronautics and Space Administration; PRT = peer-review team.)

transmits the case to a problem-solving peer-review team of labor, management, and FRA representatives. The reports allow railroads to learn more about risks and to mitigate risks, while protecting employees from blame (22, 23). Figure 4 (above) depicts the C<sup>3</sup>RS process.

With C<sup>3</sup>RS, the peer-review teams, trained in root-cause analysis and continuous-process improvement, analyze close-call events for the root causes of accidents and recommend corrective actions. Interposed between the worker and management is a neutral third party—either the Bureau of Transportation Statistics or the National Aeronautics and Space Administration, depending on the railroad involved—that collects event reports and communicates to the railroad, protecting employee identities.

**FIGURE 5 C<sup>3</sup>RS impacts at one site (percent change).**



### Methods and Findings

Four pilot sites have implemented all elements of C<sup>3</sup>RS successfully, including third-party reporting, close-call case analysis by labor–management teams, and corrective actions. A commonly reported problem was excessive speed on the mainline track during “slow orders,” when multiple orders to slow down because of track maintenance are grouped closely together. The recommended corrective action encouraged maintaining one speed—the lowest velocity—throughout all adjacent slow orders.

Quantitative analysis of these sites showed a 31 percent decrease in human factors–related derailments for one railroad (Figure 5, below left). At the same site, tests found positive changes in many validated survey scales of safety culture (Table 3, page 35). In interviews, knowledgeable respondents indicated that disciplinary cases decreased by approximately 90 percent. Data indicated a 48 percent decrease in C<sup>3</sup>RS reports related to excess speed.

### Beyond the Pilots

ORD’s evaluation program has affected the industry in many ways (Table 4, page 35). Many labor, management, and FRA personnel who were committed to the demonstrations became advocates for system-based approaches to reduce risk and to improve safety culture. Relationships among these advocates facilitated collaboration, coalitions, and gradual industrywide culture change.

Knowledge about the demonstrations spread within the industry through research briefs, conferences and presentations, efforts of the C<sup>3</sup>RS national steering committee, and other targeted meetings, events, and activities that included labor, management, and government stakeholders. The results from the demonstrations have precipitated a variety of changes within both the industry and the U.S. Department of Transportation.

Evaluations of FRA’s 14-year evaluation program to test new approaches to improving safety and safety culture confirm that the approaches can be implemented successfully with (a) a high and sustained level of commitment and championship by the senior management of a carrier and (b) visible, active leadership from labor and management at all levels. Implementing the approaches required considerable effort, formative evaluations improved the implementations, and the success of the implementations was an accomplishment in and of itself.

The evaluations also confirmed significant positive results in improving safety and safety culture, as well as the value of change effected collaboratively by labor and management in these areas, as summarized in Table 5 (page 36).

## Acknowledgments

Many people and organizations served as partners and advisers to the federal personnel responsible for the funding, implementation, and evaluation of the demonstration projects. Appreciation is expressed to evaluation staff at the Evaluation Center, Western Michigan University; labor and management at American Commercial Barge Lines, Amtrak, Canadian Pacific Railroad, CSX, Kansas City Southern, and Union Pacific; to members and leaders of the American Public Transportation Association, the American Short Line and Regional Railroad Association, the Association of American Railroads, the Brotherhood of Locomotive Engineers and Trainmen, the Transportation Communications International Union, and the United Transportation Union; to consultants, evaluators, and researchers at Behavioral Science Technology, Inc., the Bureau of Transportation Statistics, Cyintech, Inc., Hile Group, Jacobs Engineering, and MacroSys Technical Services; to the Industrial and Organizational Psychology Program, University of Connecticut; and to The WreathWood Group.

## References

1. Leveson, N. G. *Engineering a Safer World: Systems Thinking Applied to Safety*. MIT Press, Cambridge, Massachusetts, 2011.
2. Zuschlag, M., J. Ranney, M. Coplen, and M. Harnar. *Transformation of Safety Culture on the San Antonio Service Unit of Union Pacific Railroad*. Final Report. Federal Railroad Administration, Washington, D.C. October 2012. [www.fra.dot.gov/eLib/details/L04121](http://www.fra.dot.gov/eLib/details/L04121).
3. *Program Evaluation: A Variety of Rigorous Methods Can Help Identify Effective Interventions*. GAO 10-30. U.S. Government Accountability Office, Washington, D.C., November 2009.
4. Ranney, J., and C. Nelson. *Impacts of Participatory Safety Rules Revision in U.S. Railroad Industry: An Exploratory*

**TABLE 3 Confidential Close-Call Reporting System: Safety Culture Change for Labor and Management**

| Safety Culture Scale                  | Significant Improvement Management | Labor |
|---------------------------------------|------------------------------------|-------|
| Labor–management relations            | X                                  | X     |
| Organizational fairness during change | X                                  |       |
| Supervisor fairness                   | X                                  | X     |
| Supervisor–employee relationships     |                                    | X     |
| Management safety                     | X                                  | X     |
| Raising concerns with supervisors     |                                    | X     |
| Work safety priorities                |                                    | X     |
| Helping behavior                      |                                    | X     |
| Coworker safety                       | X                                  |       |

Assessment. In *Transportation Research Record: Journal of the Transportation Research Board*, No. 1899, Transportation Research Board of the National Academies, Washington, D.C., 2004, pp. 156–163.

5. Ranney, J., and C. Nelson. *The Impact of Participatory Safety Rules Revision on Incident Rates, Liability Claims, and Safety Culture in the U.S. Railroad Industry*. Report No. DOT/FRA/ORD-07/14. Federal Railroad Administration, Washington, D.C., 2007. [www.fra.dot.gov/eLib/details/L01613](http://www.fra.dot.gov/eLib/details/L01613).
6. Coplen, M., and J. Ranney. *The Impact of Safety Rules Revisions on Safety Culture, Incident Rates, and Liability Claims in the U.S. Railroad Industry*. Research Results RR03-03. Federal Railroad Administration, Washington, D.C., January 2003. [www.fra.dot.gov/eLib/details/L03554](http://www.fra.dot.gov/eLib/details/L03554).
7. Johnson, K., L. O. Greenesid, S. A. Toal, J. A. King, F. Lawrenz, and B. Volkov. *Research on Evaluation Use: A Review of the Empirical Literature from 1986 to 2005*. *American Journal of Evaluation*, Vol. 30, 2009, pp. 377–410.
8. Wu, S., J. Ranney, M. Zuschlag, and M. Coplen. *Cooperative Root-Cause Analysis and Corrective Actions for Reducing Injuries and Improving Safety Culture: Implementation and Outcomes of Canadian Pacific’s Investigation of Safety-Related Occurrences Protocol (ISROP)*. Federal Railroad Administration, Washington, D.C. (in preparation).

**TABLE 4 Safety Culture Changes Influenced by ORD Program**

| Organization                                     | Changes   |
|--|---|
| Canadian Pacific                                 | Systemwide policy change, with emphasis on systems instead of individuals   |
| Toronto Transit                                  | Systemwide safety culture program   |
| Union Pacific Railroad                           | Systemwide total safety culture program   |
| Federal Railroad Administration                  | Risk-reduction program  |
| Congress   | Rail Safety Improvement Act of 2008 requires railroads to develop risk-reduction programs that systematically evaluate risk. (“The Secretary may conduct behavior-based safety and other research, including pilots before promulgating regulations....”) |
| Amtrak   | Safe-to-Safer Program: \$20 million effort aimed at organizational culture change, improved collaboration, and peer-to-peer safety  |
| BNSF   | Safety leadership development   |
| Norfolk Southern                                 | Peer-to-peer electronic distraction pilot   |
| U.S. Department of Transportation Safety Council | Includes a safety culture action team to spread safety culture within the department  |

**TABLE 5 Summary of Results Across All Pilots**

| Approach                                 | Functions           | Outcomes   |
|--|---------------------|--|
| Participative Safety Rules Revision      | All operating       | <ul style="list-style-type: none"> <li>• 30% reduction in reportable injuries</li> <li>• Drop in liability claims</li> </ul>   |
| Root-Cause Analysis Problem Solving      | Mechanical          | <ul style="list-style-type: none"> <li>• 50% drop in injury rates (all injuries)</li> </ul>  |
| Clear Signal for Action                  | Station services    | <ul style="list-style-type: none"> <li>• 76% drop in injury rates</li> <li>• 71% drop in reportable injuries</li> </ul>  |
|  | Road crews          | <ul style="list-style-type: none"> <li>• 79% drop in locomotive engineer decertification rates</li> <li>• 81% drop in derailments</li> </ul>                                       |
|  | Yard crews          | <ul style="list-style-type: none"> <li>• 62% drop in yard-derailment rates</li> </ul>  |
| Confidential Close Call Reporting System | Road and yard crews | <ul style="list-style-type: none"> <li>• 31% reduction in derailments at one site</li> <li>• 90% drop in disciplinary cases</li> <li>• 48% drop in excess-speed reports</li> </ul> |

- Coplen, M., and M. T. Lee. *Canadian Pacific Railway Investigation of Safety-Related Occurrences Protocol Considered Helpful by Both Labor and Management*. Research Results RR06-13. Federal Railroad Administration, Washington, D.C., September 2006. [www.fra.dot.gov/eLib/Details/L03518](http://www.fra.dot.gov/eLib/Details/L03518).
- Krause, T. R. *Employee-Driven Systems for Safe Behavior: Integrating Behavioral and Statistical Methodologies*. Van Nostrand Reinhold, New York, 1995.
- Geller, E. S. Behavior-Based Safety in Industry: Realizing the Large-Scale Potential of Psychology to Promote Human Welfare. *Applied and Preventive Psychology*, Vol. 10, pp. 87–105 (2001).
- Juran, J. M. *Managerial Breakthrough: A New Concept of the Manager's Job*. McGraw-Hill, New York, 1964.
- Harrington, H. J. *The Improvement Process: How America's Leading Companies Improve Quality*. McGraw-Hill, New York, 1987.
- Krause, T. R., K. J. Seymour, and K. C. M. Sloat. Long-Term Evaluation of a Behavior-Based Method for Improving Safety Performance: A Meta-Analysis of 73 Interrupted Time-Series Replications. *Safety Science*, Vol. 32, 1999, pp. 1–18.
- Cook, S., and T. E. McSween. The Role of Supervisors in Behavioral Safety Observations: A Case Study Examination of an Ongoing Debate. *Professional Safety*, 2000, pp. 33–36.
- Coplen, M., J. Ranney, and M. Zuschlag. *Behavior-Based Safety at Amtrak—Chicago Associated with Reduced Injuries and Cost*. Research Results RR07-07. Federal Railroad Administration, Washington, D.C., February 2007. [www.fra.dot.gov/eLib/details/L03506](http://www.fra.dot.gov/eLib/details/L03506).
- Coplen, M., J. Ranney, and M. Zuschlag. *Decreases in Collision Risk and Derailments Attributed to Changing At-Risk Behavior Process at Union Pacific*. Research Results RR09-20. Federal Railroad Administration, Washington, D.C., September 2009. [www.fra.dot.gov/eLib/details/L01342](http://www.fra.dot.gov/eLib/details/L01342).
- Zuschlag, M., J. Ranney, and M. Coplen. Program Evaluation of an Organizational Change Program for Union Pacific Road and Yard Operations Shows Improved Safety Performance and Safety Culture. Submitted for publication in *Safety Science*.
- Coplen, M., J. Ranney, and M. Zuschlag. *Clear Signal for Action Program Addresses Locomotive Cab Safety Related to Constraining Signals*. Research Results RR07-08. Federal Railroad Administration, Washington, D.C., February 2007. [www.fra.dot.gov/eLib/details/L03505](http://www.fra.dot.gov/eLib/details/L03505).
- Coplen, M., J. Ranney, and M. Zuschlag. *Improved Safety Culture and Labor—Management Relations Attributed to Changing At-Risk Behavior Process at Union Pacific*. Research Results RR09-19. U.S. Department of Transportation, Federal Railroad Administration, Washington, D.C., September 2009. [www.fra.dot.gov/eLib/details/L01462](http://www.fra.dot.gov/eLib/details/L01462).
- Coplen, M., and J. Ranney. *Safe Practices, Operating Rule Compliance, and Derailment Rates Improve at Union Pacific Yards with STEEL Process*. Research Results RR09-08. Federal Railroad Administration, May 2009. [www.fra.dot.gov/eLib/Details/L04248](http://www.fra.dot.gov/eLib/Details/L04248).
- Derailments Decrease at C<sup>3</sup>RS Sites at Midterm*. Research Results RR12-04. Federal Railroad Administration, Washington, D.C., 2012. [www.fra.dot.gov/rpd/downloads/RR\\_Derailments\\_Decrease\\_C3RS\\_Site\\_at\\_Midterm\\_final.pdf](http://www.fra.dot.gov/rpd/downloads/RR_Derailments_Decrease_C3RS_Site_at_Midterm_final.pdf); [www.fra.dot.gov/eLib/details/L03582](http://www.fra.dot.gov/eLib/details/L03582).
- Raslear, T., J. Ranney, and J. Multer. *Confidential Close-Call Reporting System: Preliminary Evaluation Findings*. Research Results RR08-33. Federal Railroad Administration, Washington, D.C., December 2008. [www.fra.dot.gov/eLib/Details/L04249](http://www.fra.dot.gov/eLib/Details/L04249).

The Sunnyside rail yard in Queens, New York, was the site of an Amtrak pilot test of the Confidential Close-Call Reporting System.



Photos: Rowan, Flickr

## Fatigue Research Improves Regulatory Effectiveness

THOMAS G. RASLEAR AND COLLEEN A. BRENNAN

The Rail Safety Improvement Act of 2008 (RSIA) authorized the U.S. Secretary of Transportation to prescribe additional regulations governing the hours of service by train and engine employees in rail passenger transportation. The Secretary delegated this authority to the head of the Federal Railroad Administration (FRA).

Before the RSIA, Congress had raised questions about the safety of split shifts in passenger service. In split shifts, individuals work the morning peak period, have at least four hours off duty in the middle of the day—called “interim release”—and then return to work for the evening peak. Employees working split shifts therefore may be awake for long periods of time, which may increase fatigue. When employees are fatigued, human factors accidents are more likely. FRA’s regulatory impact analysis, however, indicated that alternatives to split shifts would require railroads to hire more employees and would limit pay for current employees.<sup>a</sup>

The RSIA required that the regulations consider “scientific and medical research related to fatigue and fatigue abatement [and] railroad scheduling and operating practices that improve safety or reduce employee fatigue.” To support the rulemaking, FRA surveyed passenger train employees about their work schedules and sleep patterns.<sup>b</sup> The findings showed that employees in split shifts worked 7.6 hours, compared with 7.9 hours by employees who worked straight through, without an interim release.

Interim releases ranged from 4 to 9 hours, with a median time of 5.1 hours. Two-thirds of the interim release periods coincided with sleep, as split-shift workers offset workday sleep deficits by napping during the interim release. FRA researchers analyzed the work and sleep schedules with the Fatigue Avoidance Scheduling Tool, a biomathematical model of performance and fatigue, and concluded that split-shift workers were less fatigued than passenger train employees whose schedules did not include an interim release.



PHOTO: NEFF CONNER

*A worker commutes on the Dallas Area Rapid Transit Red Line in Texas. FRA researchers studied fatigue impacts of split shifts, or shifts with long off-duty breaks in between peak work periods, and found that split-shift employees often were less tired than workers on regular shifts.*

The research revealed that the majority of split-shift workers used the interim release for napping and were less fatigued than other passenger train employees. Consequently, FRA’s regulation has allowed split shifts and interim release to continue in passenger service, avoiding the need for scheduling changes that would have been costly for rail carriers and employees.

The RSIA had stipulated that if hours-of-service regulations for passenger train employees were not issued and put into effect within three years, the statutory hours-of-service provisions for freight train employees would apply to passenger train employees as well. The RSIA was enacted on October 16, 2008; FRA met the statutory deadline, and the rule became effective on October 15, 2011.

---

*Raslear is Chief, Human Factors Research Division, Office of Research and Development, and Brennan is Trial Attorney, Office of the Chief Counsel, Federal Railroad Administration, Washington, D.C.*

<sup>a</sup> Federal Register, Vol. 76, No. 156, p. 50390.

<sup>b</sup> [www.fra.dot.gov/eLib/details/L01305](http://www.fra.dot.gov/eLib/details/L01305).



PHOTO: TRB STAFF

An FRA study examined the causes behind an approximately 65 percent drop in injuries, fatalities, and collisions at highway-rail grade crossings.

■ ■ ■ ■ ■ ■ ■ ■ ■ ■  
**Railroads and Research**  
Sharing Track

# Success Factors in the Reduction of Highway-Rail Grade Crossing Incidents

SUZANNE M. HORTON AND MARCO P. daSILVA

*The authors are with the Research and Innovative Technology Administration, Volpe National Transportation Systems Center, Cambridge, Massachusetts. Horton is Operations Research Analyst, and daSilva is Engineer, Systems Safety and Engineering Division.*

**I**n the past 20 years, safety at public highway-rail grade crossings has improved significantly. Despite increases in motor vehicle and train traffic, collisions at grade crossings have declined by approximately 65 percent, fatalities by approximately 63 percent, and injuries by approximately 65 percent (1).

The collaboration of many agencies and organizations that share the goal of reducing grade crossing incidents, fatalities, and injuries has driven these trends. In addition, major research initiatives by the Federal Railroad Administration (FRA) have provided the information to support implementation of industry guidance, policies, and rules, which have provided a significant safety benefit.

The improvements in grade crossing safety were evident, but the factors and initiatives that contributed to the successes had not been identified. FRA therefore funded a two-phase study to determine the safety factors that had an impact on the reduction of highway-rail grade crossing incidents from 1994 to 2007 (2, 3). The study identified possible factors in grade crossing incident reduction and applied data from the FRA Railroad Accident-Incident Reporting System (RAIRS) to estimate the impact of each factor. A similar study by Mok and Savage focused on the reduction in grade crossing incidents and fatalities from 1975 to 2001 and credited highway safety improvements as the greatest influence on safety (4).

## Identifying Success Factors

Extensive reviews of the literature and discussions with subject matter experts identified 11 factors as likely contributors to the improvement in grade crossing safety. The factors included rulemakings, changes or advances in the grade crossing and transportation environment, and political, societal, and economic changes. Most of the 11 factors were associated with a significant FRA research effort.

### **Commercial Driver Safety**

During the period of study, national legislation placed a greater emphasis on commercial driver safety. The Motor Carrier Safety Improvement Act of 1999 established the Federal Motor Carrier Safety Administration, with the primary mission of reducing crashes, injuries, and fatalities involving large trucks and buses. In October 1999, the law on Commercial Driver Disqualification stated that the licenses of commercial drivers convicted of violating warning devices at a highway–rail grade crossing would be suspended.<sup>1</sup>

### **Locomotive Conspicuity**

Making locomotives more conspicuous aids drivers not only in seeing an oncoming train, but in judging its distance and speed. The Locomotive Safety Standards, effective December 1997, stated that all locomotives that exceed 20 mph at a crossing must have auxiliary alerting lights in addition to the headlights.<sup>2</sup>

Before the rulemaking, FRA undertook research to evaluate the effects of various locomotive headlight configurations on motorists' decision making and published the results (5).

### **More Reliable Motor Vehicles**

Automobiles manufactured during the period of study increased in safety and reliability. A more reliable vehicle reduces the possibility of breaking down or stalling while crossing railroad tracks and being struck by an oncoming train.

### **Sight Lines Clearance**

The clearing of vegetation and the removal of obstructions at grade crossings enables highway users to observe the tracks and any oncoming trains at farther distances from the crossing. Adequate sight distance allows highway users to stop safely, reducing the risk of collision with an unexpected or undetected train. The U.S. Department of Transportation established a technical working group in 2002 to determine calculations for adequate sight distance (6).

### **Grade Crossing Maintenance Rule**

The final rule on Grade Crossing Signal System Safety, issued in 1995, stated that railroads must implement specific maintenance, inspection, and testing requirements for active crossing warning systems.<sup>3</sup> Regular maintenance and inspection were intended to reduce the risk of warning device malfunction.

<sup>1</sup> 69 Code of Federal Regulations (CFR) 48104.

<sup>2</sup> 49 CFR 229.

<sup>3</sup> 49 CFR 234.



PHOTO: TRB STAFF

FRA requires all locomotives exceeding 20 mph at a crossing to have auxiliary alerting lights—which increase perceptibility for drivers—as well as headlights.





PHOTO: BRETT VA

Street markings and flashing lights at a Washington State rail crossing protect pedestrian traffic.

Construction crews build a bridge to grade-separate a CSX crossing in Bladensburg, Maryland. U.S. Congress appropriated funds to improve highway-rail grade crossings under Section 130, Title 23, of the U.S. Code.

**Freight Car Reflectorization**

The final rule on Reflectorization of Rail Freight Rolling Stock, effective March 2005, mandated the application of retroreflective sheeting to the sides of freight cars and locomotives in a specified color and pattern. FRA conducted extensive research to determine the value of adhering reflectors to freight rail cars and the optimal size and pattern for the application.<sup>4</sup> The full research report was published in 1999 (7).

**Pedestrian Safety**

New devices and technologies installed at grade crossings protect pedestrian traffic. The FRA Office of Safety has worked with states, railroads, and other stake-

<sup>4</sup> 49 CFR 224.



PHOTO: ANDREW BOSSI

holders to identify and catalogue pedestrian-specific treatments at highway-rail grade crossings (8).

**Crossing Closure and Grade Separation**

In 1991, the FRA Administrator recommended the closing of 25 percent of all crossings. Of the 292,839 public and private at-grade crossings at the end of 1990, 70,004 had been closed as of 2008. Closures and grade separations reduce the risk of a collision to nearly zero.

**Warning Device Upgrades**

Upgrading to crossing warning devices that have a higher effectiveness value reduces the risk of a collision. States and communities routinely evaluate warning devices at crossings for upgrades and safety improvements.

**Education and Enforcement**

Communities are taking a proactive approach by educating the public on the dangers of highway-rail grade crossings and by discouraging risky behavior at crossings with active enforcement. Operation Lifesaver is an international organization that provides education and awareness programs to prevent tragic collisions, fatalities, and injuries at highway-rail grade crossings and on railroad rights-of-way. The FRA-sponsored Public Education and Enforcement Research Study traced the effects of the initiatives on reducing risky behavior at highway-rail grade crossings (9).



IMAGE: OPERATION LIFESAVER

Operation Lifesaver posters and other safety resources bring public awareness to safety at rail crossings and railroad rights-of-way.

**Crossing Improvement Programs**

Congress appropriates highway funds for safety improvements to highway-rail grade crossings under Section 130, Title 23, of the U.S. Code. States apply the funds, and each state implements its own crossing improvement plan. The Section 130 program overlaps other success factors, since the funds are used also to close, separate, and upgrade crossings.

**Research Methodology**

The first phase of the research on success factors analyzed the reduction in highway-rail grade crossing incidents from 1994 to 2003. The second phase analyzed the continued decline in incidents from 2003 to 2007.

Seven of the 11 factors considered in the study were estimated with data from the RAIRS: commercial driver safety, locomotive conspicuity, grade crossing maintenance, more reliable motor vehicles, sight lines clearance, freight car reflectorization, and pedestrian safety. The remaining four were analyzed qualitatively and with data from outside RAIRS: warning device upgrades, education and enforcement, crossing improvement programs, and crossing consolidation–grade separation.

The RAIRS data fields indicated that the incident characteristics implied the influence of one or more of the factors. For example, an incident with a commercial vehicle would be influenced by the commercial driver safety factor. Assigning incidents to the success factors made it possible to analyze the factors' impacts.

The impact of the factors analyzed with grade crossing data from RAIRS was estimated with two metrics—percent impact and percent reduction. The percent impact is the percentage of incidents attributable to behaviors that the factor was attempting to change. The percent reduction is the percentage of incidents reduced that can be attributed to the safety countermeasures. Together, these two metrics provided a complete estimate of the factors' impact on the reduction of incidents.

To estimate each factor's contribution to improving highway–rail grade crossing safety, each incident during the study period was assigned to an individual factor, to a combination of factors, or to no identified factor. The assignment was made based on the RAIRS data fields for each incident. If the characteristics of the incident indicated multiple factors, it was assigned to a combination of factors; if none of the factor characteristics was present in the incident, it was assigned to no identified factor. This ensured that the incidents were not counted multiple times for different factors, inflating the factors' impacts.

The contributions of the factors that were not analyzed with RAIRS data were investigated through other relevant studies and with data available from other sources, such as the National Highway–Rail Grade Crossing Inventory.

## Results and Analyses

The percent impact and percent reduction were calculated for the factors in each phase of the study. The results are shown in Table 1 (below).

During the first phase, from 1994 to 2003, improvements in commercial driver safety and locomotive conspicuity made the largest contributions to the reduction in incidents. The analysis during the second phase revealed that the safety benefits from regulations and measures introduced during the 1990s had been fully realized by 2007.

The study from 2003 to 2007 was a shorter period, with fewer incidents included in the analysis, which magnified any variability in the annual data. Negative values in the results table do not imply that the factor caused an increase in incidents, but that no further benefits were derived from those factors after the first phase.

Two additional factors were included in the second phase of the study: pedestrian safety and freight car reflectorization. Neither the RAIRS Grade Crossing database nor the Crossing Inventory indicates the type of pedestrian warning device or treatment at a crossing. Therefore, evaluating the effects of pedestrian warning devices was not possible; the data show the trend of pedestrian incidents as a whole.

The increase in pedestrian incidents from 2003 to 2007 did not reflect the effectiveness of any particular warning device or safety program. This could be a result of variability and fluctuations from year to year because of fewer incidents during the second phase of the study. The finding also could indicate that the installation of new pedestrian devices should be more widespread.

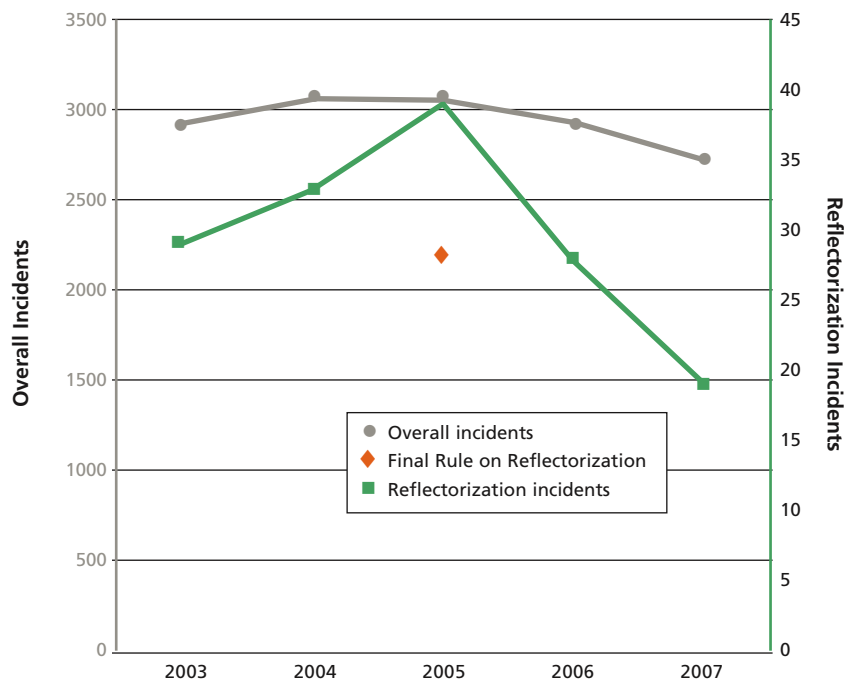

PHOTO: MICHAEL HICKS

Warning device upgrades were among the success factors considered in the FRA study.

**TABLE 1 Percent Impact and Percent Reduction for Identified Success Factors**

|                              | Percent Impact |           | Percent Reduction |           |
|------------------------------|----------------|-----------|-------------------|-----------|
|                              | 1994–2003      | 2003–2007 | 1994–2003         | 2003–2007 |
| Commercial driver safety     | 21.8           | 18.7      | 34.6              | 1.02      |
| Locomotive conspicuity       | 15.0           | 15.5      | 15.6              | –5.1      |
| Grade crossing maintenance   | 1.2            | 1.4       | 3.1               | 4.6       |
| More reliable motor vehicles | 1.9            | 1.6       | 3.1               | 3.1       |
| Sight lines clearance        | 2.6            | 1.8       | 3.7               | 4.6       |
| Freight car reflectorization | -              | 1.0       | -                 | 5.1       |
| Pedestrian safety            | -              | 1.8       | -                 | –8.7      |



**FIGURE 1**  
Reflectorization incidents and overall incidents, 2003–2007.

Although the time period for the second phase was shorter and the data set therefore less extensive, the improvements from making freight cars more visible with reflectorization were evident after the passage of the 2005 rule. Figure 1 (above) presents the impact of the improvements.

Although analyzed with a different methodology and additional data sources, warning device upgrades and crossing closures were effective strategies in improving safety at grade crossings. Crossing closures eliminate nearly all risk of incidents, injuries, and fatalities at that location; crossing closures showed one of the strongest impacts on the reduction in incidents. The effects of education and enforcement and of crossing improvements were difficult to analyze quantitatively, but other studies and reports have indicated the effectiveness of these factors in improving highway–rail grade crossing safety.

### Value of Research Investments

These findings highlight the value of several major research initiatives undertaken by the federal government and industry to improve highway–rail grade crossing safety. During the study of success factors for 1994 to 2003, commercial driver safety and locomotive conspicuity were the two greatest successes in reducing incidents. Although the number of incidents related to freight car reflectorization was relatively small during the 2003 to 2007 study period, the data showed a discernible downturn after the final rule went into effect in 2005. Crossing closures also showed a significant impact on the reduction of incidents.

Many of the factors identified were the result of major research initiatives by the federal government, industry, or other stakeholders. The research investment in highway–rail grade crossing safety has provided significant safety improvement. The implementation of the research investments, particularly for locomotive conspicuity and freight car reflectorization, has yielded real-world safety benefits. The study results also revealed factors that did not have an impact on the reduction in incidents or that have not fully realized the benefits. These results highlight areas for new safety research efforts.

Investing in highway–rail grade crossing safety research has reduced the number of incidents between highway users and trains. FRA continues to improve highway–rail grade crossing safety with research and development.

This study underscores the value of investing in safety-related research and using the results in regulatory, policy, or technological changes and advances. The differing results from the two phases of the study also show the need for research to evolve and to identify and explore new means to improve safety at highway–rail grade crossings.

### References

1. Railroad Accident–Incident Reporting System. Office of Safety Analysis, Federal Railroad Administration, Washington, D.C. <http://safetydata.fra.dot.gov>. Accessed November 2012.
2. Horton, S., A. A. Carroll, M. Chaudhary, J. Mozenter, T. Ngamdung, and D. Skinner. *Success Factors in the Reduction of Highway–Rail Grade Crossing Incidents, 1994 to 2003*. Report DOT/FRA/ORD-09/05. Federal Railroad Administration, Washington, D.C., April 2009.
3. Horton, S. *Success Factors in the Reduction of Highway–Rail Grade Crossing Incidents*. Presented at 89th Annual Meeting of the Transportation Research Board, Washington, D.C., January 2010.
4. Mok, S., and I. Savage. Why Has Safety Improved at Rail–Highway Grade Crossings? *Risk Analysis*, Vol. 25, No. 4, November 2005, pp. 867–881.
5. Carroll, A. A., J. Multer, and S. H. Markos. *Use of Auxiliary External Alerting Devices to Improve Locomotive Conspicuity*. Report DOT/FRA/ORD-95/13. Federal Railroad Administration, Washington, D.C., July 1995.
6. Highway–Rail Grade Crossing Technical Working Group. *Guidance on Traffic Control Devices at Highway–Rail Grade Crossings*. Federal Highway Administration, Washington, D.C., November 2002.
7. Carroll, A. A., J. Multer, D. Williams, and M. Yaffee. *Safety of Highway–Rail Grade Crossings: Freight Car Reflectorization*. Report DOT/FRA/ORD-98/11. Federal Railroad Administration, Washington, D.C., January 1999.
8. *Compilation of Pedestrian Safety Devices in Use at Grade Crossings*. Office of Safety, Federal Railroad Administration, Washington, D.C., January 2008.
9. Sposato, S., P. Bien-Aime, and M. Chaudhary. *Public Education and Enforcement Research Study*. Report DOT/FRA/ORD-06/27. Federal Railroad Administration, Washington, D.C., June 2006.

# Grade Crossing Electronic Document Management Systems

*Developing a Cost-Effective, Comprehensive Inventory and Project Management Tool*

STEVE LAFFEY

Highway–rail grade crossings are critical transportation junctures. According to the Federal Railroad Administration (FRA), 11,118 train–vehicle collisions occurred at these sites between 2006 and 2011 that resulted in 4,637 injuries and 1,403 fatalities to highway users, train passengers, and railroad employees. Reducing the number of collisions is an important public policy goal.

Maintaining accurate information about grade crossing engineering, as well as operational and safety characteristics, in an easy-to-use information management system can assist in achieving this goal. The system could identify high-risk grade crossings, as well as the most efficient, cost-effective improvements to reduce the risk of incidents.

The American Association of State Highway and Transportation Officials (AASHTO) has established a technology implementation group (TIG) to document and promote state-of-the-art grade crossing information systems, known as Grade Crossing Electronic Document Management Systems. The high-payoff, ready-to-use, innovative technology already is proving highly beneficial to states and their industry partners.

The systems are designed to collect and manage the day-to-day highway–rail crossing inventory specified on the U.S. Department of Transportation's (DOT's) form.<sup>a</sup> The system provides electronic updates to the National Highway–Rail Grade Crossing and Structure Inventory file, facilitating railroad-related internal communications, electronic document storage,



PHOTO: AMOCKLEY, FLICKR

Accurate information about engineering and safety characteristics of grade crossings can help reduce collisions.

and expedited external and interagency communications between the state DOT, the public utility commission (PUC), railroad companies, and FRA.

Typically developed with the highway–rail crossing inventory as the core module, the systems are designed to accommodate add-on data modules for improvement program development, collision tracking, crossing inspections, and geographic information systems mapping. The systems can incorporate photographs, scanned images of documents, and other information, and can link to other state DOT systems to share data. The systems also can be Internet- or intranet-based and can communicate electronically with all partners in the grade crossing arena—for example, railroads, PUCs, FRA, and the Federal Highway Administration.

Systems developed by Pennsylvania, Illinois, Virginia, North Carolina, and several other states have realized these communication benefits. The states' systems have facilitated internal communications about railroad crossings, as well as external communications between the state DOT, FRA, and railroad companies. The partners are able to submit and view securely via the web all documents that pertain to joint projects.

The TIG executive committee has formed a lead state team including FRA, Illinois, North Carolina, Pennsylvania, and Virginia. The team has surveyed states and railroads to identify the state of the art, as well as the components of an ideal system. The survey results and complete information on the Grade Crossing Electronic Document Management Systems TIG are available at <http://tig.transportation.org/Pages/GradeCrossingElectronicDocumentManagementSystem.aspx>.

*The author is Railroad Safety Specialist, Illinois Commerce Commission, Springfield, and Chair, TRB Highway–Rail Grade Crossing Committee.*

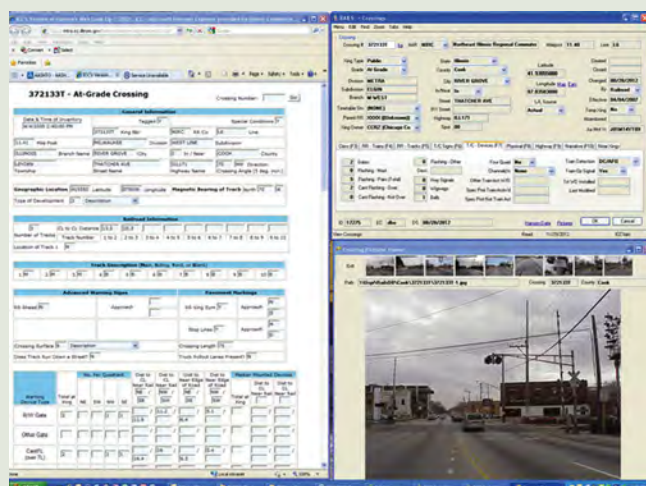

Sample screen shot of an information system.

<sup>a</sup> Crossing Inventory Form FRA F6180.71.

## On Track for Railroad Crossing Safety

### North Carolina's Sealed Corridor Program

PAUL C. WORLEY

In 1992, the U.S. Department of Transportation (DOT) designated five national high-speed rail corridors, including one connecting Washington, D.C., Raleigh, and Charlotte, North Carolina. Since then, North Carolina has received funds to improve at-grade railroad crossing safety along its portion of the Southeast High-Speed Rail (SEHSR) corridor.

North Carolina DOT's Sealed Corridor Program aims to improve or consolidate every public and private crossing along the section of the SEHSR corridor connecting Raleigh, Greensboro, and Charlotte. Although public agency involvement in private crossings—which generally are under the jurisdiction of the railroad companies—had no legal precedent, the Private Crossing Safety Initiative has focused on the same safety goals as for public crossings, has inventoried and evaluated all private crossings on the corridor, and has recommended signalization, signage, or closure.

North Carolina DOT also has conducted comprehensive traffic separation studies to identify crossings for near- and long-term improvements, including consolidation or replacement with bridges or with safer parallel crossings.

The Sealed Corridor Initiative has demonstrated devices to enhance safety at highway–railroad grade crossings. Video-monitored tests in the 1990s documented a 67 percent to 98 percent reduction in gate violations, depending on the treatments. An analysis by the U.S. DOT's Volpe Center estimated that a potential 19.7 lives were saved as a result of the projects implemented on the corridor through December 2007.

The enhanced devices and strategies that were evaluated included the following:

◆ **Median separators.** Installed along the centerline of a roadway and extending approximately 70 to 100 feet from



PHOTO: NORTH CAROLINA DOT

*Median separators prevent motorists from crossing lanes to avoid activated gates.*

the crossing, the separators prevent motorists from crossing lanes to get around the activated gates. The median devices may be tubes, or flat delineator panels attached to a prefabricated island, or a concrete monolith with tubes. The devices have reduced crossing violations by 77 percent.

◆ **Four-quadrant gates.** The gates block all lanes of travel across the railroad tracks when the signals are activated and have decreased violations by up to 86 percent.

◆ **Combinations of median separators with four-quadrant gates** have reduced violations by 98 percent.

◆ **Longer gates.** Extending across three-fourths of the roadway at a crossing, longer gates reduce a driver's ability to dodge around and have decreased violations by 84 percent.

In addition, special signage can indicate the stopping point for vehicles, provide a phone number for reporting signal outages, or remind drivers not to stop their vehicles on the tracks. Equipment monitoring was found to be a valuable part of a centralized communications system, notifying railroad personnel in a timely way about malfunctions in crossing equipment.

Federal Railroad Administration (FRA) grants and state funds supported the initial projects of the Sealed Corridor Program. Additional grade separations and closures are now being built through FRA's High-Speed Intercity Passenger Rail Program and are scheduled for completion by 2017. Copies of FRA research and development reports are available at [www.fra.dot.gov/Page/P0001](http://www.fra.dot.gov/Page/P0001).



PHOTO: NORTH CAROLINA DOT

*Four-quadrant gates block all lanes of travel across railroad tracks when signals are activated.*

*The author is Rail Division Director, North Carolina Department of Transportation, Raleigh.*



PHOTO: DON BARRETT

■ ■ ■ ■ ■ ■  
**Railroads and  
Research**  
Sharing Track

# Developing and Implementing Positive Train Control at BNSF Railway

LARRY MILHON

*The author recently retired as Director, Train Dynamics, BNSF Railway.*

**B**NSF Railway began development of its electronic train management system (ETMS) in 2003 to prevent train collisions and derailments. The ETMS is a positive train control (PTC) system, which works in conjunction with railroad operations by interfacing with signal systems, wayside devices, and office train dispatch systems via communication links. A PTC system warns the locomotive engineer about the need for action and, if necessary, will automatically stop a train to prevent train-to-train collisions, overspeed derailments, incursions into work zones, and movements through improperly aligned switches.

Field signal systems and computer-aided dispatch (CAD) systems—which assist dispatchers in authorizing and monitoring train movement—generate mandatory directives for a train’s movements, speed restrictions, and work zone limits. The ETMS enforces compliance; the field signals, which govern the crew’s operation of the train, and the dispatcher still maintain train separation and protection.

The technology of the ETMS combines proven products from other industries—such as the Global Positioning System and very high frequency (VHF)

packet radio—with new tools that have a high potential for success in data collection and decision making applications. The ETMS provides onboard delivery and enforcement of authorizations and speed restrictions, onboard display of a track map, signal-aspect speed enforcement, switch-position monitoring, track-integrity monitoring, and an onboard braking system to prevent overspeeding and authority violations. BNSF is working with Wabtec Railway Electronics in the ongoing development of the ETMS.

### Initial Development

Initial ETMS development and implementation took place on the Beardstown Subdivision in Central Illinois, a territory with relatively light traffic that operates with centralized traffic control, which directs the movement of trains with signals controlled from a central location, and with track warrant control, in which a dispatcher in a central location verbally authorizes train movements by radio communication with train crews. The ETMS implementation developed techniques for surveying and for identifying critical features. Initial revenue service demonstra-

A BNSF freight train in the Tehachapi Loop near Bakersfield, California.

tions began in 2004, and the ETMS received approval in 2006 for grades of up to 1 percent on single track with sidings.<sup>1</sup>

After gaining extensive experience in the Beardstown Subdivision, BNSF implemented and tested the ETMS on portions of the Fort Worth Subdivision in Texas and the Red Rock Subdivision in Oklahoma, including areas of double-track operation—that is, with two parallel mainline tracks. As a result, the ETMS was certified for operation in territories with double track.

BNSF worked with Amtrak in 2008 to add ETMS passenger operation on lines with centralized traffic control with up to 1 percent grade. In winter 2009, BNSF successfully conducted mountain-grade braking tests in the Stampede Subdivision in Washington State, and the ETMS gained certification for freight trains on grades of up to 2.2 percent.

Under the Rail Safety Improvement Act of 2008, the next release of the ETMS must include features for interoperability with other PTC systems. In 2010, Version VI of the ETMS achieved certification as a nonvital overlay PTC system.

## Migration to I-ETMS

ETMS VII is the last version before a changeover to Interoperable ETMS (I-ETMS), the industry standard. ETMS VII introduced new 220-MHz radios, a new messaging interface, and a wayside interface compatible with the I-ETMS for major Class 1 railroads.

The Southern California passenger rail system Metrolink is testing ETMS VII on the BNSF San Bernardino Subdivision as an interim step toward full I-ETMS compliance.<sup>2</sup>

<sup>1</sup> 49 CFR 236, Subpart H.

<sup>2</sup> [www.metrolinktrains.com/pdfs/Agency/PTC\\_Fact\\_Sheet\\_1.pdf](http://www.metrolinktrains.com/pdfs/Agency/PTC_Fact_Sheet_1.pdf).

## Braking Algorithm

The braking algorithm is a fundamental component of the ETMS. The calculation enables the system to warn the engineer to apply the brakes and stop short of a hazard. The development of the algorithm was challenging—if the calculated stopping distance is too small, the system will not stop the train short of the hazard; but if the results are too conservative, the system's warning will force the engineer to slow the train too soon. A slowdown reduces the railroad's average train speed and can lead to a dramatic loss of capacity, critical on a busy line.

The Federal Railroad Administration's (FRA's) Office of Research and Development sponsored a project to optimize the braking calculation. The work is ongoing at the Association of American Railroads' Transportation Technology Center, Inc., near Pueblo, Colorado, and continues to produce improvements to the braking algorithm.

Because the cost of telecommunications is a significant challenge for all mobile data systems, a decision was made early in the design process to minimize the data traffic. Instead of sending information about each car in the train, only a summary of the train consist is sent—the train's weight, length, and number of loads and empties.

A braking algorithm, however, calculates the train's total brake force. With only summary information about a train, the calculation of total brake force could vary by as much as 50 percent, because some cars have high-capacity brakes and some have empty-and-load brake valves. BNSF decided to calculate the total brake force in the central control or back office, because detailed information about the train consist is readily available via a mechanical database known as UMLER.

The total brake force result is sent to the onboard system as part of the message about the train's consist. The onboard system recognizes that 5 percent of the brakes could be cut out in all calculations. With this process, the braking algorithm can reduce the safety margin or cushion and maintain the required level of safety.

Distributed power offers another improvement in the braking algorithm; locomotives are placed at intermediate points within or at the ends of a train, and the engineer in the locomotive at the front of the train remotely controls the distributed locomotives. A train with distributed power stops much shorter than one without distributed power, because the brake pipe reduction can be propagated from both ends. This solution is in testing but should be incorporated in a future release of the ETMS software.

To enforce train operations, the ETMS currently uses a full-service penalty brake application, actuated

A Metrolink video demonstrates positive train control (PTC).



by a safety control device, which produces the maximum train-braking effort without engaging the emergency brake system. More than 25 variables must be considered in calculations for a penalty brake application. Some of the values are well known, but the exact value of each variable cannot be known with absolute certainty; in some cases, therefore, assumed values are used, relying on historic norms.

If too many variables differ from the assumed values for any particular train, however, the train stop distance calculation could fall outside the expected range. To counter this, the safety cushion could be increased. Another option would be for the train's emergency brake system to cover these rare events. This approach has been pilot-tested and appears to work well; a future release of the ETMS software will include this solution.

Using the emergency brake, however, will require a thorough investigation of the air brake interface to guarantee that the train will have enough air left to initiate the emergency brake, if needed.

## Data Radio and Communications

The initial ETMS rollout used a 44-MHz radio network to transmit data and a proprietary wireless protocol developed by MeteorComm, a telecommunications firm. The radio network had limitations in throughput and message density and was not suited for extensive deployment across multiple railroads or for supporting interoperability with other PTC systems.

The Class 1 railroads have acquired 220-MHz frequencies for an interoperable PTC spectrum. The frequencies offer propagation characteristics that are suitable for the fixed spacing of railroad signals and other assets.

MeteorComm developed a software-defined radio from specifications and requirements identified by the Interoperable Train Control Technical Team, a railroad industry committee charged with establishing standards and coordinating efforts for interoperability. The software-defined radio, which automatically achieves optimum communication performance, operates in the 217- to 222-MHz spectrum range with channel spacing of 25 kHz. The device is required to support PTC subsystem integration, system qualification testing, FRA system certification, and widespread deployment by December 31, 2015.

A messaging protocol, developed by MeteorComm to specifications and requirements from the Interoperable Train Control Technical Team, is not available as a commercial off-the-shelf product. With support from FRA, MeteorComm developed a software-defined radio that incorporated a messaging

PHOTO: SNEEBLY, FLICKR



Class 1 railroads operate 220-MHz frequencies for an interoperable PTC spectrum.

protocol and a wireless protocol for the interoperable communication system.

Software-defined radio offers increased flexibility for implementing changes in communications protocols, as well as simplicity of design, because the radio functions can be implemented on general-purpose processors. This flexibility also reduces deployment risks, making it possible to deploy expensive infrastructure or large numbers of mobile devices without locking in a communications standard. This protects the user from potential changes and market uncertainties. Designing a reliable, economical radio that can operate over long periods in the railroad environment has proved a challenge.

## Employee-in-Charge Application

A potential enhancement to the ETMS involves enforcement of the speed limits around a work zone. Speed limits currently are relayed to the train via voice communication; PTC systems, however, work primarily with digital data.

The application in development therefore would allow the employee in charge (EIC) of a work zone to transmit entry permission electronically to PTC-equipped trains, with speed and stop instructions. The PTC system would enforce the instructions when the train enters the work zone. The electronic permission transmitted to the PTC-equipped locomotive would supplement the standard voice communication.



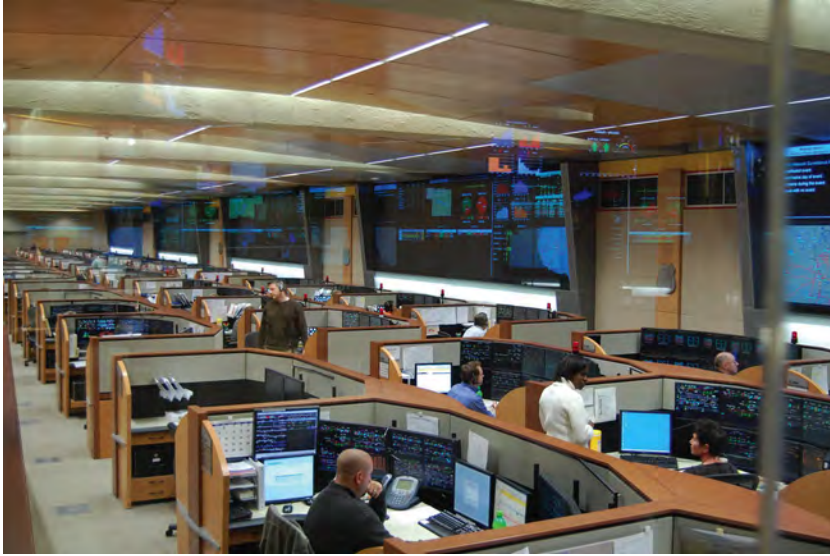

PHOTO: AMERICA'S POWER

Union Pacific's Harriman Dispatching Center. BNSF's central control plays a key role in the employee-in-charge enhancement to the ETMS.

Approaching a work zone, a PTC-equipped locomotive would send a request for entry to the PTC's back office segment—the central control location for the equipment that electronically issues authorizations for train movements—which would forward the request to the work zone's EIC application. The EIC would give both electronic and verbal permission for the train to enter the work zone in accordance with the General Code of Operating Rules.<sup>3</sup> The PTC-equipped locomotive would hold to the specified speed, which may range from maximum track speed to 5 mph, to a restricted speed, or to values in between. The EIC also may specify stop-and-wait—the PTC locomotive would have to stop at a certain location and await further instructions.

Transportation Technology Center, Inc., is developing the EIC application with funding from the FRA Office of Research and Development and BNSF. BNSF plans to test the function in ETMS VII. The

<sup>3</sup>GCOR Rule 15.2.

Track data from the BNSF San Bernardino Subdivision in California were collected and loaded into a simulator program to study the safety impacts of PTC.

development and implementation of the interface between the I-ETMS and the EIC application also is planned, but not for the initial rollout.

## Train Control Simulations

The PTC development process requires verification and validation—which include a demonstration that the key features are functioning. The FRA Office of Research and Development sponsored the development of the Generalized Train Movement Simulator (GTMS) to simulate railroad operations with and without the PTC system. The program showed that PTC improved safety.

The program simulated the movement of all trains across a specific territory and identified possible locations for incidents. The program modeled the same trains with the PTC system in place and analyzed the events to determine if a collision or derailment would have resulted.

For example, statistics show the number of times that a train not equipped with PTC may pass a red signal without stopping; sometimes the failure to stop will result in a collision and sometimes not. By modeling historic traffic data, a rate can be developed for the opportunity for collisions to occur. The same trains are modeled in the simulations with the PTC system in place, and a new opportunity value is developed. The difference is the improvement in safety. The regulations require a nonvital overlay PTC system to show a risk improvement greater than 80 percent.<sup>4</sup>

BNSF worked with FRA and the program developer to evaluate the Mendota Subdivision in Illinois and the San Bernardino Subdivision in California. The track data were collected for each territory and loaded into the GTMS program. Historic traffic data were collected and modeled for a 25-year span to develop the baseline opportunity values. The GTMS program used safety statistics from the ETMS VII Positive Train Control Safety Plan to determine the improvement opportunities. Both studies showed risk improvements far exceeding the 80 percent requirement.

## Making Progress

The ETMS has progressed a long way from initial testing—data radios have been updated, braking performance has improved, and EIC terminals are showing great promise. Substantial work remains to reach the interoperable safety system required by the Rail Safety Improvement Act of 2008. The cooperation of the Class 1 railroad community and the continued support of the FRA Office of Research and Development will achieve this goal.

<sup>4</sup>49 CFR 236, Subpart I.



PHOTO: PATRICK DIRKEN

## Mobile Locomotive Simulator for Human Factors Research

*The Federal Railroad Administration's Cab Technology Integration Laboratory*

GINA MELNIK



PHOTO: VOLPE NATIONAL TRANSPORTATION SYSTEMS CENTER

**T**he Cab Technology Integration Laboratory (CTIL) is a mobile, full-sized locomotive simulator configured with tools for analyzing crew performance with new cab technologies and configurations. The CTIL is owned by the Federal Railroad Administration (FRA) and housed and operated by staff at the Volpe National Transportation Systems Center in Cambridge, Massachusetts. Unlike most locomotive cab simulators, the CTIL was designed specifically for human factors research.

The CTIL provides a platform for research into human-machine interface in relation to human performance, enabling assessment of the safety impact of various technologies, procedures, concepts of operations, and operating scenarios. The lab is a national resource available to railroad, industry, academic, and government researchers, facilitating collaborations.

CTIL's capabilities and features include the following:

- ◆ *System mobility*, which allows packaging and transport to other laboratories, rail facilities, and demonstration venues;
- ◆ *A reconfigurable cab*, which can accommodate new control, display, and automation technologies, as well as components such as new seating;
- ◆ *Scenario customization*, which adjusts track, grade, signals, signage, scenery, and more to create experimental scenarios for any project;
- ◆ *Postrun analysis*, which allows for visualization of locomotive crew performance based on the track, consist, and locomotive state and compares crew performance against the standards set for the scenario;
- ◆ *Audio and video recording*, which offers several video and audio recording channels;

---

*The author is Engineering Psychologist, Volpe National Transportation Systems Center, Research and Innovative Technology Administration, Cambridge, Massachusetts.*

*The Federal Railroad Administration's Cab Technology Integration Laboratory (CTIL) is a full-size locomotive simulator designed specifically for human factors research.*

- ◆ *Video data analysis*, which allows live coding of behavior and environmental occurrences for analysis and aids in the retrieval of relevant segments of video;
- ◆ *High-fidelity head-and-eye tracking system*, which can identify, record, and analyze the engineer's head and eye movements;
- ◆ *Anthropometric and behavioral modeling tools*, which allow for manipulation and animation of human manikins in a three-dimensional representation of the cab, useful for evaluating control and display positions, visual angles, and other ergonomic considerations; and
- ◆ *Locomotive crew task and workload modeling software*, which permits the modeling of crew behavior and performance—such as task completion times, workload, and the potential for human error.

FRA and Veolia Transdev are collaborating on a CTIL project to improve understanding of human error caused by distraction during locomotive railroad operations. The study examines the effect of distraction on practicing locomotive engineers who operate the simulator over animated track segments while experiencing a variety of distractions. The goal is to develop an effective, comprehensive training program in sustained attention for railroad engineers and conductors. Measures of head and eye movement are being applied, as well as other operator performance measures—such as speed maintenance, proper stopping distances, adherence to signals, and temporary speed restrictions.

For more information about the CTIL or about collaboration with FRA to use the CTIL, contact Michael Jones at michael.e.jones@dot.gov.

## Trip Optimizer

### Autocontrol System Saves Fuel

SUNEIL KUTHIALA



PHOTO: TRB Staff

The Trip Optimizer, an autocontrol system for locomotives, makes velocity calculations that save fuel by minimizing brake applications for a specific train and track topography. Figure 1 (below) presents a simplified block diagram of the Trip Optimizer, which was developed in 1995 at the GE Research Center in Niskayuna, New York.

Before departure, an off-board system provides the detailed train makeup and locomotive information to the onboard systems via a wireless link. Database information about the

CSX has installed more than 1,300 Trip Optimizer units on its locomotives.

track on the route is stored on board; the off-board system transfers the current data as of the start of the trip. When all the information is mapped to the locomotive and validated by the operator, the optimal velocity profile is calculated for the entire trip. This profile passes to the locomotive's control system, which drives the train, so that the Trip Optimizer handles all throttle control for motoring and for dynamic braking—a closed loop operation.

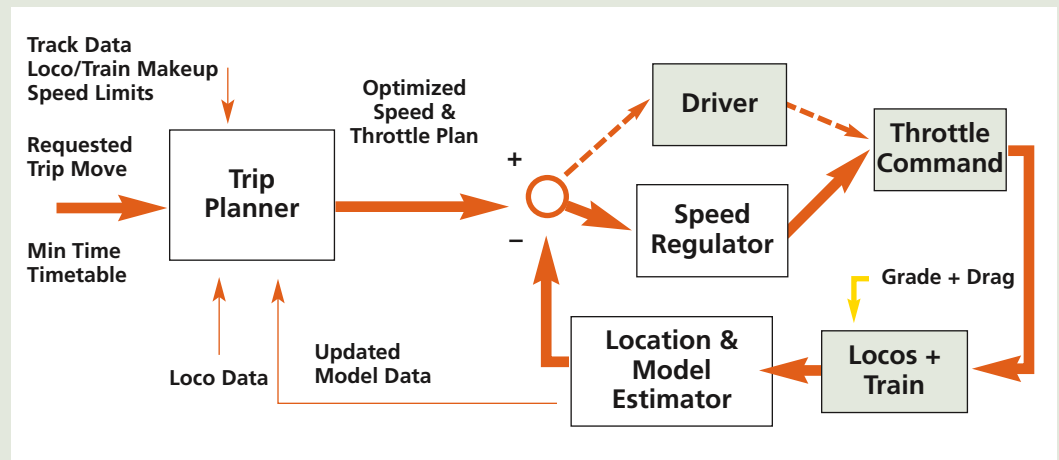
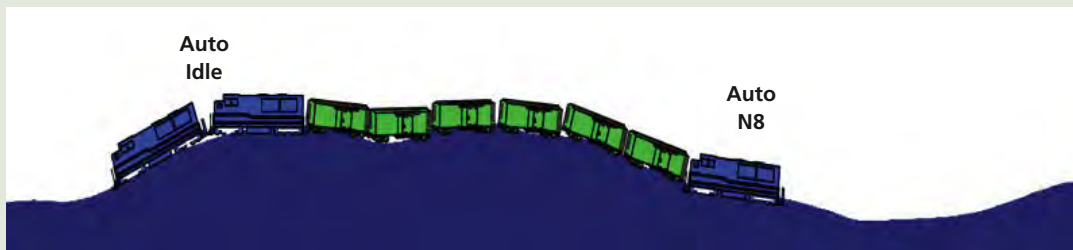

FIGURE 1 Diagram of Trip Optimizer information and systems (min = minimum, loco = locomotive).



**FIGURE 2** The Trip Optimizer calculates different locomotive throttle settings to determine the best configuration for fuel savings. As shown, the throttles of the two lead locomotives are set to idle on the downgrade, while the remote locomotive remains in Throttle Notch 8 (N8) going up the grade.

Nearly 2,000 locomotives are equipped with the Trip Optimizer, running on more than 45,000 miles of track on several railroads in North America. Tests have demonstrated fuel savings that range from 3 percent to 17 percent, depending on the train type and the topography. The system operates on all freight train types with configurations that vary from 800 to 30,000 trailing tons, up to 15,000 feet long, with a horsepower per ton (HPT) that ranges from 0.5 to 10 HPT.

The Trip Optimizer can control conventional and Locotrol distributed power (DP) trains, which allow the locomotives to operate away from the lead consist—for example, at the end of the train—via a radio link. The remote loco-

motives can push the cars, reducing the tensile stress on the couplers throughout the train. Good train handling techniques sometimes demand that the DP locomotive operate at a power setting different from that of the lead locomotive, depending on the terrain. This capability is built into Locotrol DP in the asynchronous or independent mode.

CSX has installed more than 1,300 Trip Optimizer units on its locomotives; many of these contain the

first production release of the Auto Independent feature. These units primarily run on long, heavy coal trains from Irwin, Tennessee, to Spartanburg, South Carolina. The feature allows the Trip Optimizer to adjust the different throttle settings of the lead and remote locomotives in the consist au-

tomatically, as depicted in Figure 2 (above). This significantly reduces the workload for the train's engineer and ensures good train handling and optimal fuel savings.

The next release of the Trip Optimizer for CSX, scheduled for later this year, will include the Trip Optimizer SmartHPT feature (Figure 3, below). SmartHPT promises incremental fuel savings by powering the minimum

required number of locomotives while maintaining the originally planned speed and travel time. SmartHPT redistributes the horsepower demand to fewer locomotives to increase the consist efficiency. This effectively changes the train's HPT rating and decreases fuel consumption. SmartHPT is expected to achieve a fuel savings of 3 percent.



IMAGE COURTESY SWEET KOTHIYALA

The Trip Optimizer handles throttle control for motoring and dynamic braking based on a route's topography. Fuel savings range from 3 to 17 percent.

The author is Director, Advanced Engineering, CSX Transportation, Inc., Jacksonville, Florida.



**FIGURE 3** Trip Optimizer SmartHPT can calculate the optimal use of locomotive power and can dynamically autostart, shut down, or isolate locomotives as needed during a trip.

# Diverse Motivations Strengthen Rail Research

ANTHONY PERL

The author is Professor of Urban Studies, Simon Fraser University, Vancouver, British Columbia, Canada, and Chair of the TRB Rail Group.



PHOTO: HEATH ALSBIE

The Denver Rail Yard reflects the diversity of industry needs—from carriers to shippers to travelers.

Railroads boost economic productivity by moving goods and people efficiently. The railroad system gains from robust research and development initiatives that advance the understanding of technology, operating practices, and organizational structure. As the articles in this issue of *TR News* show, research results prove their value by saving lives and money and by reducing rail's ecological impact in meeting mobility needs. Railroad research is focused on building new knowledge into a venerable mode of transportation.

Railroad research reflects diverse priorities—the varied needs of carriers, shippers, travelers, and government—as well as the distinctive means for seeking new knowledge preferred by industry, government, and universities. Accounting for why today's railroad research is being pursued can offer important insight into how this knowledge is being advanced and can reveal some of the forces that shape research performance, facilitating strategies to improve results.

## Three Approaches

The aspirations that motivate railroad research range from enhancing commercial performance to creating public benefits to satisfying innate curiosity. Given the predominantly private ownership of railroads in North America, as well as the important role played by private enterprise in railroading throughout the world, industry's goals for research have a major influence on the search for knowledge. With the intensified flow of ideas and information across the globe, rail research in North America increasingly is connected to investigations initiated on other continents. But whether North American rail research leads or follows international efforts, three approaches intersect to shape its attributes.

### Private Industry

Private industry participation in rail research maintains a business focus. Industrial researchers and their corporate sponsors apply the discipline of the market to analytical efforts. The expected research

*POINT OF VIEW* presents opinions of contributing authors on transportation issues. Readers are encouraged to comment in a letter to the editor on the issues and opinions presented.

output must make a measurable contribution to a railroad operator or to a supplier's profitability within a reasonable time, to justify launching and sustaining a research activity.

Therefore translating rail research results into either safety improvements or monetary benefits, or a combination of both, needs to remain sufficiently clear and certain during the life of the research project. But uncertainty is inherent in research, and private industry regularly reviews its research programs to assess whether the anticipated contribution to profitability remains realistic. This kind of evaluation favors investigations that show promise in delivering expected benefits and identifies unexpected outcomes that could diminish or qualify the benefits. The anomalies that often arise in research activity receive close scrutiny, and if uncertainty about the expected benefits crosses a certain threshold, the research efforts could be restructured or curtailed. Industry's scrutiny reduces—but never eliminates—the risk that rail research may arrive at a dead end after considerable investment of time and money.

### Public Sector

Public-sector support for rail research extends this bottom-line calculus of what to explore, and how far to pursue it, by recognizing less tangible benefits and less widely shared payoffs that can be created by new or improved rail technology and techniques. This broadened focus on the value added from research can advance findings that are hard to monetize because their effects are spread across society or around the world, as with innovations that reduce railroads' greenhouse gas emissions. Research also can produce tangible results for everyone in a community, as with breakthroughs to reduce the noise from railroad operations. In these circumstances, the real value that spreads beyond the financial bottom line of a single organization can justify public support for research that otherwise may not have priority.

### Universities

The third approach to rail research arises from the academic world, in which creating new knowledge is a valued end in itself. The curiosity-driven research that is pursued at universities and national laboratories has contributed to significant breakthroughs in propulsion and communications technology and has improved the materials used in rail equipment and infrastructure. But this path to payoffs often proves to be lengthy and convoluted.

Academic institutions and the grants councils and foundations that support basic research usually take a long view about the time to attain results, tolerating uncertainty and unexpected outcomes. Outputs



PHOTO: UNIVERSITY OF ILLINOIS AT CHAMPAIGN-URBANA

that are not ready for immediate adoption by industrial users often require an intermediate stage of applied research to translate the potential value into results. Academic sponsors rely on others to accomplish the transitional efforts and place a high value on the educational benefits of training aspiring professionals through research. Student participation in research activities builds capability not only in research, but also across society.

### Aligning the Approaches

Aligning these diverse motivations can enhance the effectiveness of rail research. Industry, government, and academic orientations each bring strengths to measuring and managing research. Industry can place a clear value on potential payoffs from research and can distinguish promising results from less auspicious efforts and unproductive findings. Government's ability to recognize research goals that could result in wider benefits to society—and the public sector's higher tolerance for uncertainty about the risk of reaching a dead end—can bolster research

Internships and site visits are key components of railway engineering education at the National University Rail Center (NURail) at the University of Illinois at Champaign-Urbana.

NURail research on concrete crossties and fastening systems, including tests conducted at the Transportation Technology Center, Inc. (TTCI), near Pueblo, Colorado, addresses the challenge of operating higher-speed passenger and heavy axle-load freight trains on shared rail corridors.



PHOTO: UNIVERSITY OF ILLINOIS AT CHAMPAIGN-URBANA

NURail is the first federally funded University Transportation Center devoted to rail research.



PHOTO: UNIVERSITY OF ILLINOIS AT CHAMPAIGN-URBANA

efforts that require incubation. University researchers can uncover valuable breakthroughs—or the key ingredients that enable breakthroughs—by pursuing questions less obviously connected to immediate needs. Although these three orientations can be at odds with one another, the increasing articulation of railroad research delivery has encouraged interconnection of these different perspectives on the value of research activity.

#### ***Fostering Innovative Synergy***

The Federal Railroad Administration's Transportation Technology Center in Pueblo, Colorado, represents an exemplary venue for creating these synergies, integrating the research strengths of industry, government, and academic institutions. Launched as the U.S. Department of Transportation's (DOT's) High-Speed Ground Test Center and funded by the High-Speed Ground Transportation Act of 1965, the center was intended to introduce high-speed passenger trains to the United States. After early efforts lost momentum, the facility hosted the research and development for a range of railroad needs. In 1998, the Transportation Technology Cen-

The public-sector, industry, and university approaches to rail research are integrated at TTCI.

ter, Inc. (TTCI), a wholly-owned subsidiary of the Association of American Railroads (AAR), took over the long-term management of the center.

TTCI operates on a fee-for-service basis and welcomes research projects supported by governments, private railroads, and equipment suppliers, as well as academic initiatives. The facility provides a unique research infrastructure, both in terms of the hardware and of the links between the private, public, and academic rationales for pursuing new knowledge. TTCI facilitates an innovative synergy between public and private research cultures. U.S. DOT's recent renewal of support for academic research has opened the way for innovative approaches that can leverage the capacity of America's colleges and universities.

#### ***Assembling Expertise***

U.S. DOT funds 22 University Transportation Centers (UTCs) across the United States. In 2012, for the first time, a UTC received funding with a mandate to pursue railroad research. The National University Rail Center (NURail), based at the University of Illinois at Champaign-Urbana, includes as partners the University of Illinois at Chicago, the University of Kentucky, Michigan Technological University, Massachusetts Institute of Technology, the University of Tennessee at Knoxville, and the Rose-Hulman Institute of Technology. NURail has assembled the advanced expertise in rail research that had been diffused across many academic institutions. This critical mass of skills and competencies can multiply the know-how devoted to the successful conduct of rail research. Reconciling the motivations behind the pursuit of rail research will increase the will to persevere during tough times.

#### **Bright Prospects**

Demand is volatile today for all forms of mobility, reflecting the economic turbulence of global markets since 2008; the value of railroad research is more important than ever. When profitability appears vulnerable, industry may find research and development budgets a tempting target. Similarly, public-sector research budgets come under pressure when governments address deficits.

But cutbacks in the efforts to discover new technology and techniques to advance railroading will come at a significant future cost. The value of research results can be measured by a common monetary denominator, but the value of the discoveries emanating from research will vary depending on where the assessment is being made. When these diverse perspectives complement each other, the prospects for demonstrating the long-term value of rail research appear bright.



PHOTO: U.S. SENATOR MARK UDALL



# Improving Railroad Track Maintenance Scheduling with Operations Research Techniques

YANFENG OUYANG

*The author is Associate Professor, Department of Civil and Environmental Engineering, University of Illinois at Urbana–Champaign.*

CSX Transportation spends hundreds of millions of dollars every year on railroad track maintenance activities, routing large crews and heavy machinery throughout its extensive railroad networks. Effective planning saves on maintenance costs and resources and affects the safety and operational efficiency of the maintenance activities. Operations research techniques offer opportunities to facilitate and improve the decision-making process.

## Problem

The scheduling of track maintenance involves a series of highly complex activities. Thousands of miles of tracks must be inspected regularly to identify defects. The defects are grouped into projects, and each project comprises a workload suitable for specialized maintenance teams. The teams travel around the network to complete all projects, aiming at efficient travel schedules and complying with thousands of business rules, including technological and operational requirements.

The main outputs are a series of timetables that specify the inspection plan, the project composition, and the maintenance teams' travel schedules. Additional considerations include how many inspection or maintenance teams should be hired the following year, how the workloads can be balanced across teams, and the cost in resources.

## Solution

Through collaborative research, the University of Illinois at Urbana–Champaign (UIUC) and CSX Transportation have developed a series of sophisticated models and tools to address these considerations. The problem was divided into three main parts:

1. Scheduling rail inspections (1),
2. Clustering jobs into projects (2), and
3. Scheduling maintenance teams (3, 4).

To schedule the inspections, the railroad network is divided into hundreds of segments. Each segment is inspected periodically to ensure the safety of train operations. The schedule specifies the activities assigned to each inspection team, as well as the starting times of the activities, so that all of the required



Photo: CSX

CSX track inspection.

inspections can be completed. The inspection teams must optimize their routes, to spend less time traveling between activities that may be far apart.

The model also satisfies a variety of business constraints—for example, the teams should not have to work during weekends and holidays, and no more than one team should be working at any time within a subdivision, which is the basic unit of analysis for traffic operations in the railroad network.

## Clustering Jobs

Thousands of track maintenance jobs—such as the replacement of track components and other major repairs—are identified for maintenance teams to perform in the following year. The model clusters the jobs into projects, so that each project spans full weeks, because the machinery must be relocated on weekends, when the teams are not working.

Sometimes a maintenance team can work overtime at extra cost to reduce a project's duration. A major goal of the model is to minimize the total number of weeks needed to complete a project, reducing



Photo: CSX

Maintenance activities.



**TABLE 1 Estimated Improvements for Full-Scale Implementation**

| Model                       | Performance Metric     | Reduction (%) |
|-----------------------------|------------------------|---------------|
| Rail inspection scheduling  | Travel distance        | 25.0          |
| Job clustering              | Total project duration | 11.0          |
| Maintenance team scheduling | Travel distance        | 13.6          |

the labor costs, and to select projects for overtime work. In clustering jobs, the model must accommodate many operational constraints. For example, clustering certain jobs in different subdivisions could cause difficulties in rescheduling train traffic.

### Addressing Constraints

After the projects are created, the team assignments and schedules are determined. The routes of teams must be optimized to reduce the total travel costs between projects, as well as other costs that may arise. For example, certain projects may require additional devices and procedures in winter; multiple ongoing projects within adjoining subdivisions or in major corridors may block train traffic and should be avoided. The model addresses thousands of such requirements.

All of these problems are formulated into large-scale network routing and scheduling models with many complex constraints. These were solved by developing a variety of advanced operations research and optimization techniques with customized features. For example, the rail inspection scheduling problem was solved with a local search algorithm in an incremental scheduling horizon framework. The job clustering problem was solved with a multistep heuristic search algorithm. The maintenance team scheduling problem was solved with a multiple neighborhood search algorithm and mixed integer programming subroutines.

### Application

The collaboration between CSX Transportation and UIUC on track inspection and maintenance scheduling started in 2008. The CSX Operations Research Department focused on providing business requirements and data, and the UIUC team focused on developing mathematical models and solution algorithms. The researchers held weekly teleconferences to update each other on the project's progress.

Experts from the CSX engineering department reviewed the solutions at every development phase; in addition, comparisons were made with state-of-the-art benchmark solutions. The UIUC researchers received feedback on model enhancements and modifications. This solution-and-review process was repeated throughout the project to ensure that the models were accurate and the results were implementable.

The CSX decision-support system incorporated the three main models between 2009 and 2011, and the results were impressive. The new modeling approaches proved effective, efficient, and suitable for full-scale practical use and have provided CSX with functional schedules. The success of this project also strengthened the collaboration between CSX and the UIUC Rail Transportation and Engineering Center.

### Benefits

The performance of the implemented models, estimated for recent years of operation from the railroad's actual information, was compared with the state-of-the-practice benchmark solutions; Table 1 (above, left) summarizes the results. As shown, the models that were developed yielded better solutions in the three aspects of track maintenance scheduling. The inspection and maintenance team scheduling models reduced the total travel distances for inspection teams by 25.0 percent and for maintenance teams by 13.6 percent; the job clustering model reduced the total duration of projects by 11 percent.

The decision tools offer the advantage of working fast; for example, the solution time for the full-scale maintenance team scheduling problem formerly required one week under the state-of-the-art manual solution process; this has been reduced to only a couple of hours. CSX now can conduct a what-if analysis efficiently to optimize resource planning for material and manpower. These optimization approaches have helped CSX save millions of dollars in the past few years.

For more information, contact Yanfeng Ouyang, 1209 Newmark Civil Engineering Laboratory, University of Illinois at Urbana-Champaign, 205 North Mathews Avenue, Urbana, IL 61801; yfouyang@illinois.edu; or 217-333-9858;

### References

1. Peng, F., Y. Ouyang, and K. Somani. Periodical Rail Inspection Scheduling in Large-Scale Railroad Networks. Working Paper, University of Illinois at Urbana-Champaign, 2012.
2. Peng, F., and Y. Ouyang. Optimal Clustering of Railroad Track Maintenance Jobs. *Computer-Aided Civil and Infrastructure Engineering*. In review, 2013.
3. Peng, F., S. Kang, X. Li, Y. Ouyang, K. Somani, and D. Acharya. A Heuristic Approach to Railroad Track Maintenance Scheduling Problem. *Computer-Aided Civil and Infrastructure Engineering*, Vol. 26, No. 2, 2010, pp. 129–145.
4. Peng, F., and Y. Ouyang. Track Maintenance Production Team Scheduling in Railroad Networks. *Transportation Research Part B*, Vol. 46, No. 10, 2012, pp. 1474–1488.

EDITOR'S NOTE: Appreciation is expressed to Amir N. Hanna, Transportation Research Board, for his efforts in developing this article.

Suggestions for Research Pays Off topics are welcome. Contact G. P. Jayaprakash, Transportation Research Board, Keck 488, 500 Fifth Street, NW, Washington, DC 20001 (202-334-2952; gjayaprakash@nas.edu).

# CALENDAR

## TRB Meetings

### July

- 9–10 National Congestion Pricing Conference\*  
Seattle, Washington
- 11–12 8th SHRP 2 Safety Symposium  
Washington, D.C.
- 14–17 8th International Conference on Road and Airfield Pavement Technology\*  
Taipei, Taiwan
- 16–19 Workshop on the Future of Road Vehicle Automation  
Palo Alto, California
- 17–19 20th International Symposium on Transportation and Traffic Theory\*  
Noordwijk, Netherlands
- 21–24 52nd Annual Workshop on Transportation Law  
Nashville, Tennessee
- 22–25 Transportation: Driving a Sustainable Urban Environment  
New Brunswick, New Jersey

### August

- 4–7 International Symposium of Climatic Effects on Pavements and Geotechnical Infrastructure\*  
Fairbanks, Alaska

- 14–16 Barge and Rail Symposium: Moving Freight Between Multimodal Systems\*  
Louisville, Kentucky
- 19–23 Transportation Hazards and Security Summit and Peer Exchange  
Irvine, California
- 20–21 Roadway Safety Culture Summit  
Washington, D.C.
- 26–27 7th New York City Bridge Conference\*  
New York, New York

### September

- 23–27 Smart Rivers 2013\*  
Liège, Belgium; Maastricht, Netherlands

### October

- 10–11 Shared-Use Mobility Summit\*  
San Francisco, California
- 16–17 Transit GIS Conference\*  
Washington, D.C.
- 21–22 Innovations in Freight Modeling and Data: Integrating Supply-Chain Models and Data into Public-Sector Freight Demand Modeling  
Herndon, Virginia

- 23–25 7th International Visualization in Transportation Symposium: Visualization for Big Data  
Irvine, California

- TBD Development of a Formalized Process for the Adoption, Development, Maintenance, and Enhancement of TransXML Schemas Workshop  
Washington, D.C.

### December

- 12–15 2nd Conference of the Transportation Research Group of India\*  
Agra, India

## 2014

### January



- 12–16 TRB 93rd Annual Meeting  
Washington, D.C.  
[www.TRB.org/AnnualMeeting](http://www.TRB.org/AnnualMeeting)

### March

- TBD Transportation Planning, Land Use, and Air Quality Conference\*  
Charlotte, North Carolina

Additional information on TRB meetings, including calls for abstracts, meeting registration, and hotel reservations, is available at [www.TRB.org/calendar](http://www.TRB.org/calendar). To reach the TRB staff contacts, telephone 202-334-2934, fax 202-334-2003, or e-mail [TRBMeetings@nas.edu](mailto:TRBMeetings@nas.edu). Meetings listed without a TRB staff contact have direct links from the TRB calendar web page.

\*TRB is cosponsor of the meeting.

## Anthony D. Perl

*Simon Fraser University*

Anthony Perl's research crosses disciplinary and national boundaries to explore the policy decisions that affect transportation, cities, and the environment. "As a political scientist, I look for ways to educate transportation professionals about governance and teach those in government about transportation," he comments.

Perl received a bachelor's degree in government from Harvard University and master's and doctoral degrees in political science from the University of Toronto, where he also served as C. A. Ashley Fellow at Trinity College and as instructor in the Department of Political Science from 1990 to 1993. Perl also taught at the Université Lumière Lyon, France; the University of Calgary; and at the City University of New York before joining the faculty of Simon Fraser University in Vancouver in 2005.



**"Successful transportation engineers, designers, planners, and managers recognize how politics shapes their environment and find ways to participate effectively in political decision making so that the resulting projects can work better."**

Perl is professor of political science and urban studies at Simon Fraser University. As the first full-time Director of Urban Studies at Simon Fraser University from 2005 to 2012, he guided the development of a graduate curriculum focused on making cities more sustainable. He has taught courses on urban research, transportation and urban development, and public policy analysis.

Although politics plays an integral role in transportation planning, development, and operation, the effects of politics often are taken for granted in subsequent analyses of transportation projects, Perl notes. "When transportation professionals criticize a decision as having been shortchanged by 'politics,' they are missing the point—that it will always require politics to reconcile the interests and values that shape any big decision about mobility," he observes. "Successful transportation engineers, designers, planners, and managers recognize how politics shapes their environment and find ways to participate effectively in political decision making so that the resulting projects can work better."

Perl studies how politics creates institutional structures for transportation finance and governance in North America, Europe, and Asia, and why innovations are embraced in some

areas but ignored in others—high-speed rail, for example. Participation in TRB has allowed Perl to become involved in research about a variety of modes, to integrate many different subjects, and to apply ideas to practice. "TRB has enabled me to personally experience how breakthroughs can be generated by connecting the knowledge of different disciplines and perspectives," he observes.

Perl has been active on TRB committees since 1997, when he was appointed to the Steering Committee for the National Conference on Critical Issues for the Future of Passenger Rail and to a Transit Cooperative Research Program project panel on new paradigms in public transportation. In 1998, Perl joined the Intercity Passenger Rail Committee; he served as chair from 2006 to 2011. He also has served on the Environmental Impacts of Aviation Committee, as well as on two National Cooperative Highway Research Program panels. He now chairs the Rail Group and is a member of the Technical Activities Council and of the Oversight Committee for the new National Cooperative Rail Research Program.

As a political science professor, Perl notes that although his students generally are not transportation specialists, many will enter careers that influence mobility decisions. "I try to help them see how improving transportation will enhance the quality of life in many ways," he comments. "I look forward to seeing what the result will be of my teaching some of tomorrow's political leaders about transportation." Among his former students is Alison Redford, the Premier of Alberta, Canada.

Perl is the author of *New Departures: Rethinking Rail Passenger Policy*, published in 2002. He has coauthored or coedited several volumes, including *The Politics of Improving Urban Air Quality* (1999); *The Integrity Gap: Canada's Environmental Policy and Institutions* (2003); *Studying Public Policy: Policy Cycles and Policy Subsystems, Third Edition* (2009); and *Transport Revolutions: Moving People and Freight Without Oil* (second edition, 2010). His research has been published in many journals, including *Energy Policy*; *Transportation Research Record: Journal of the Transportation Research Board*; *Journal of Public Policy*; and *Scientific American*.

From 2008 to 2012, Perl served on the Board of Directors of VIA Rail Canada, Canada's national passenger rail service. He also was vice chair of Canada's Centre for Sustainable Transportation from 2005 to 2010 and, from 2001 to 2006, editorial board member of the journal *Policy and Society*. In 2003, Perl received the Distinguished Research Award from the University of Calgary.

## Peter F. Swan

*Pennsylvania State University, Harrisburg*

Peter F. Swan defines his role in TRB as an advocate for freight. He began his TRB service as a member of the Freight Transportation Economics and Regulation Committee in 2001 and soon was appointed chair. At the time, trucking only had one committee to address issues not related to safety, Swan recalls; as chair, he implemented a directive to work with the Transportation Economics Committee and other groups to share a focus on freight.

Working with the Transportation Economics Committee chair, the late David Forkenbrock, Swan and his committee members brought practitioners and economists together to delve into rail, trucking, and freight economics issues that previously had gone unexplored. “As highway privatization and demand-based tolling increased, Forkenbrock’s encouragement led the



**“It is the collaboration with colleagues at TRB that has both sustained my interest in transportation and deepened my understanding.”**

two committees to redouble efforts to reach out to one another. Although the process was not always smooth, it always was worth the effort and could only happen at TRB,” Swan notes.

In 2002, Swan joined the Task Force on Trucking Industry Research, which became the Trucking Industry Research Committee in 2006. He joined the Freight Systems Group in 2004, serving as group chair and member of the Technical Activities Council from 2010 to 2013. From 2005 to 2008, Swan also served as a liaison representative to the Rail Group.

Efforts to conduct outreach on freight issues led to several important breakthroughs, such as a meeting in Boston in which truckers explained to other attendees that most over-the-road drivers are not paid by the hour, but by the mile; therefore, from a trucking firm’s perspective, drivers’ time was worth much less than most economic models previously had assumed. “There was a literal ‘aha’ moment as several meeting participants gained an understanding that they did not previously have,” Swan recalls.

Swan graduated with a bachelor’s degree from the University of Michigan (UM) in 1977. He worked for General Motors Corporation before earning a master’s degree in business administration from the University of Tennessee in 1980. From

1980 to 1987, Swan held various positions at CSX Transportation, working in operations—terminal trainmaster, assistant terminal trainmaster, assistant to the division manager, and operations analyst—and in marketing. As market manager, Swan guided special projects for new service and line rationalization and participated in an award-winning project to start railroad service between Detroit, Michigan, and Atlanta, Georgia. He also served as a liaison between automotive marketing and other departments.

In 1987, Swan founded Transportation Operations, Inc., a consulting company that assisted short-line railroads with acquisition studies and accounting software. He created and maintained a software system for railroad car hire and revenue accounting that included electronic data interchange of car hire and car interchange reports.

A Ph.D. in business administration from UM Business School in 1997 marked the beginning of Swan’s academic career. From 1997 to 1998, he served as adjunct researcher at UM Business School in the Trucking Industry Program, helping to develop instruments and oversee data collection for a case study of less-than-truckload firms and for a truck driver survey. He joined the faculty at the Pennsylvania State University’s Smeal College of Business in 1998 as assistant professor of supply chain management, and in 2005, Swan became assistant professor of logistics and operations management at the School of Business Administration at Pennsylvania State University, Harrisburg. He became associate professor in 2012.

In the mid-2000s, Swan noted a lack of research literature on trucking elasticity of demand—most studies were based on stated-preference models. In 2008, Swan and colleague Michael Belzer conducted an analysis of diversion from the Ohio Turnpike—which recently had raised tolls to finance expanded capacity—and presented their findings at the 2008 TRB Annual Meeting. In 2013, they published a follow-up paper in *Public Works Management & Policy*, estimating the crash costs that result from trucks diverted from the turnpike. “Neither of these papers would have been written, let alone published, had it not been for the debate fostered by conversations and presentations at TRB Annual Meetings,” Swan observes.

Other publications include papers in *Transportation Journal*, *Utilities Policy*, *Journal of Business Logistics*, and *The Economic and Labour Review*. Swan contributed chapters to the books *Engineered in Japan* (1995) and *Trucking in the Age of Information* (2005) and, in 2011, participated in a strategic review of the National Cooperative Freight Research Program.

Swan recommends that young researchers find a focus for their research pursuits and become involved in TRB committees. “It is the collaboration with colleagues at TRB that has both sustained my interest in transportation and deepened my understanding,” he comments.



**POLICY REVIEW**—TRB Executive Committee Chair Deborah Butler (*center*), with TRB Associate Executive Director Suzanne Schneider (*left*) and second Strategic Highway Research Program Director Ann Brach (*right*), participates in a meeting of the Subcommittee on Planning and Policy Review. The subcommittee met in April at the National Academies' Keck Center in Washington, D.C., to deliberate on TRB policy-oriented studies, develop opportunities for new Executive Committee initiatives, and identify critical transportation issues warranting TRB consideration.

**DISTINGUISHED MEMBER**—

For meritorious service to the Hydrology, Hydraulics, and Water Quality Committee, Wilbert O. Thomas, Jr. (*right*), received an Emeritus Award at the 2013 TRB Annual Meeting. With him are committee chair Jon Zirkle (*center*) and design section chair Brian Ray (*left*). An editorial oversight omitted Thomas from the list of emeritus members published in the March–April *TR News*, page 22.



PHOTO: STEPHEN MAHER

### New Webinar Series Shares SHRP 2 Research Results



The second Strategic Highway Research Program (SHRP 2) recently launched a new webinar series, appearing twice a month on Tuesday afternoons. The series provides a substantive summary of the research and detailed description of SHRP 2 products, as well as information about implementation opportunities and assistance from implementation partners, the Federal Highway Administration (FHWA) and the American Association of State Highway and Transportation Officials (AASHTO), and offers the perspective and experience of participants who have pilot-tested the products.

The second round of webinars begins August 6 and includes such topics as establishing monitoring programs for mobility and travel time reliability, modular pavement technology, bridges for service life beyond 100 years, incorporation of travel time reliability into the *Highway Capacity Manual*, improved economic analysis tools, composite pavement systems, and more.

SHRP 2 Tuesday topics will coordinate with the Implementation Assistance Program developed by FHWA and AASHTO ([www.fhwa.dot.gov/goshrp2](http://www.fhwa.dot.gov/goshrp2)). The program has three participation levels, with incentives to conduct proof-of-concept pilot tests, lead adopter incentives to offset costs associated with adopting innovations, and user incentives for activities such as peer exchanges.

For announcements and registration information, subscribe to SHRP 2 News at [www.TRB.org/SHRP2](http://www.TRB.org/SHRP2). Most SHRP2 Tuesday webinars offer PDH credits. Questions can be addressed to Linda Mason, [lmason@nas.edu](mailto:lmason@nas.edu).

## COOPERATIVE RESEARCH PROGRAMS NEWS

### Traffic Incident Management Performance Measurement

Effective traffic incident management (TIM) reduces the duration and impacts of traffic incidents and improves the safety of motorists, crash victims, and emergency responders. Performance measurement is a key component in improving the effectiveness of TIM programs.

Applied Engineering Management Corporation has received a \$199,991, 18-month contract [National Cooperative Highway Research Program (NCHRP) Project 07-20, FY 2012] to develop concise guidance on the implementation of TIM performance measurement for a range of transportation and incident-responding agencies. Guidance will include clear definitions and data elements for performance measures, descriptions of typical data sources and collection strategies, and an example reference database.

For further information, contact B. Ray Derr, TRB, 202-334-3231, [rderr@nas.edu](mailto:rderr@nas.edu).

### Improving the Highway Geometric Design Process

The design of a highway—three-dimensional features and accessories for drainage, traffic control, and safety—requires a well-defined process. The American Association of State Highway and Transportation Officials (AASHTO) has published highway design policy guidance since the 1940s; the underlying highway design process has remained essentially unchanged since then. An assessment of the current design process can ensure that recent advances in knowledge, such as the AASHTO *Highway Safety Manual*, and emerging issues like complete streets or flexible design are addressed appropriately.

CH2M Hill has received a \$424,968, 33-month contract (NCHRP Project 15-47, FY 2013) to develop a comprehensive, flexible design process to meet future needs of geometric designers, considering project purposes and needs, context, desired outcomes, and more.

For further information, contact B. Ray Derr, TRB, 202-334-3231, [rderr@nas.edu](mailto:rderr@nas.edu).

# Launch Pad for Transportation Careers

## Four Years of TRB's Minority Student Fellows Program

KAREN FEBEY

Since 2010, 30 talented graduate students and advanced undergraduates have participated in TRB's Minority Student Fellows Program, which promotes minority participation in transportation and in TRB. An outcome of the strategic planning process overseen by the TRB Executive Committee and developed under the leadership of TRB Associate Executive Director Suzanne Schneider, the program provides support for full-time students from underrepresented minority groups to present research-based papers on a transportation-related topic at the TRB Annual Meeting.

Selected fellows must be enrolled in a transportation-related curriculum at an eligible historically black college or university or Hispanic-serving institution in the United States. To be eligible, an institution must be a verified minority-serving school and must have an established relationship with TRB, including a TRB University Representative. The 12 minority-serving institutions that have participated to date are as follows:

- ◆ California State Polytechnic University, Pomona,
- ◆ Florida A&M University,
- ◆ Howard University,
- ◆ Jackson State University,

- ◆ Morgan State University,
- ◆ New Mexico State University,
- ◆ North Carolina A&T State University,
- ◆ South Carolina State University,
- ◆ Tennessee State University,
- ◆ Texas Southern University,
- ◆ University of New Mexico, and
- ◆ University of Texas, El Paso.

Each institution selects one student to participate in the program, which covers expenses for fellows to attend and present their transportation-related research at one of the Annual Meeting's poster or lectern sessions. Also covered are expenses for faculty mentors to accompany the fellows. TRB provides funding for these expenses, with support from other sponsors, including the Federal Highway Administration; the North Central Texas Council of Governments; Parsons Brinckerhoff, Inc.; the South Coast Air Quality Management District, California; Stantec, Inc.; and many individual contributors.

Fellows must submit their research papers for peer review by the August 1 deadline before the Annual Meeting, offering the students the chance to experience a peer-review critique. According to past fellows and faculty mentors, this critique has been helpful in sharpening their writing skills and improving presen-

---

The author is Report Review Officer, TRB.



PHOTO: REIDON PHOTOGRAPHY

2013 TRB Minority Student Fellows: (back row, left to right) Kameron A. Boggan, Jackson State University; Roberto C. Flores, California State Polytechnic University, Pomona; Lucas Guaderrama, New Mexico State University; Winsbert C. (Curt) Charles, Howard University; Davis Aluengeh, University of New Mexico; (front row, left to right) Chelse L. Hoover, Texas Southern University; Alicia Romo, University of Texas, El Paso; Kiara J. McCummings, Tennessee State University; and Matthew D. Crooks, Morgan State University. Not pictured are Andrew M. Brunner, South Carolina State University; Albert C. Onochie, North Carolina A&T State University; and Kenya A. Rolle, Florida A&M University.



At the 2011 TRB Annual Meeting, (left to right) Roger Olson, Minnesota DOT; TRB Associate Executive Director Suzanne Schneider; and James Bryant, Jr., TRB Senior Program Officer, discuss pavement crack mitigation strategies with fellow Kyle Green (right), then a student at North Carolina A&T State University.

tation quality. Fellows have presented research on such topics as bus route performance, strain behavior of ultrahigh-performance concrete, pre-crash factors between cars and trucks, demand for bicycle facilities, and the application of traffic software.

In the four years since the program was established, both the number of fellows and the number of eligible institutions have grown. In 2010, the program had four fellows from four eligible institutions; in January 2013, 14 institutions were eligible, and 12 selected a student to participate. In 2014, the program is slated to grow to 15 eligible institutions. Among the 30 fellows who have participated since 2010, 16 have been female and 14 have been male. Two-thirds of the participants have been African-American, and the rest Hispanic and Native American.

## Positive Experience

Of the 13 former fellows who took part in follow-up interviews earlier this year, six are full-time students and seven are working full-time. Among the full-time students, two are completing the transportation degree programs they were in as fellows and four are seeking new degrees—two Ph.D. students, one master's degree student, and a law student. The diverse career paths of the seven former fellows who are working full-time include transportation and pavement design engineer, traffic engineer, project engineer at a construction company, buyer for a major manufacturing company, field trainer in the oil and gas industry, and researcher at Los Alamos National Laboratory in New Mexico.

Former fellows report that their experience at the TRB Annual Meeting provided critical exposure to the range of transportation careers and fields and demonstrated the ways in which classroom theory can be applied to transportation problems. A few fellows noted that the TRB Annual Meeting was their first conference experience—they probably would not have had such an opportunity were it not for

TRB. Other fellows expressed pride that their research could make a real contribution to the field of transportation, an insight gained at the meeting. One reports that his research presentation was the highlight of his TRB Annual Meeting experience. “I liked my poster session the most,” he comments. “I felt important at this event, sharing the floor with professionals and academia’s best.”

The fellows who are working full-time commented that the TRB Annual Meeting experience helped them refine their career goals and that the networking opportunities at the meeting helped their professional growth; moreover, the fellowship stood out as a distinction on their résumés. A former fellow, now a doctoral student, notes that when she was seeking advice on applying to a transportation-related Ph.D. program, she was able to contact several faculty members she had met at the TRB Annual Meeting. Another fellow observes that including the fellowship on his resume helped him obtain an internship at a state department of transportation.

Former participants also observed that the process of carrying out their own research, writing up the results, responding to peer-review critiques, and presenting the research to transportation professionals provided them with a more nuanced understanding of the research process and improved their writing and presentation skills.

## Future Goals

As the Minority Student Fellows Program moves into 2014 and beyond, TRB will continue to refine it with the aim of enriching fellows’ TRB Annual Meeting experience and professional development. Ideas suggested by former fellows include events to connect students with potential employers in their particular fields, helping to connect their experience to a career. Many former fellows indicated a strong desire to become involved with TRB by joining standing committees—deepening their involvement in the transportation field and advancing their networking opportunities with other professionals. TRB encourages continued involvement by reserving four spots on each committee for younger members. If younger members are unable to secure a spot, they also can participate as a friend of a committee, which allows them to attend meetings and participate in regular committee functions.

To continue to expand the program, TRB seeks additional organizational and individual contributors and interested minority-serving institutions that are able to meet the eligibility requirements. For more information, contact Suzanne Schneider, 202-334-2959 or [sschneider@nas.edu](mailto:sschneider@nas.edu), or Karen Febey, 202-334-2829 or [kfebey@nas.edu](mailto:kfebey@nas.edu).

# Increasing Opportunities for Women in Transportation

## White House Forum Invites Discussion

KATHERINE F. TURNBULL AND MARSHA ANDERSON BOMAR

Approximately 60 women leaders from industry, public agencies, professional organizations, and universities convened with top-ranking personnel from the White House and the U.S. Department of Transportation (DOT) in April at the Eisenhower Executive Office Building in Washington, D.C., for a special forum on increasing the opportunities for women in transportation.

Valerie Jarrett, Senior Adviser to the President and Chair, White House Council on Women and Girls; U.S. Transportation Secretary Ray LaHood; U.S. Health and Human Services Secretary Kathleen Sebelius; Susan Kurland, Assistant Transportation Secretary for Aviation and Internal Affairs; and other speakers outlined the diverse jobs available for women throughout the transportation industry, research on women in the workforce and women leaders, and the business case for women in transportation. Small group sessions focused on education, recruitment, retention, and leadership development of women in all facets of transportation. U.S. DOT will integrate the forum results into its contributions to the Asia-Pacific Economic Cooperation Women in Transportation initiative.

Presented are two perspectives on the forum and the possible roles TRB can play in advancing the action steps.

### A Nurturing Environment

*Katherine F. Turnbull*

The combination of presentations and small group discussions provided an excellent method for sharing information, experiences, ideas, and follow-up activities.

TRB has many activities under way to expand opportunities for women in transportation, introducing younger women into the transportation community, providing networking opportunities throughout their careers, and developing leadership skills. The Young Members Council targets Annual Meeting sessions, webinars, networking opportunities, and other activities toward women and men completing their education and beginning their careers in transportation. All standing committees and task forces have four young member spots as well as extensive lists of committee friends.

The New Attendees Welcome session at the Annual Meeting helps introduce women of all ages to TRB opportunities, and the Women's Issues in Transportation Committee, regular international conferences on women's issues, and the development of research problem statements further advance the understanding of women's transportation needs.

TRB provides a nurturing environment to women at all levels in their careers. Standing committees offer an effective venue to advance many of the action items developed at the forum. The education breakout session provided an occasion for developing my "elevator" speech about attracting women to transportation careers: "If you are looking for a career that is exciting, challenging, provides growth opportunities, and makes a difference in your community, state, and country, transportation is where you want to be. Your active involvement in TRB will help throughout your career."

### Mentorship and Sponsorship

*Marsha Anderson Bomar*

Wearing several hats at this event gave me the opportunity to examine many aspects of the history and future of women in transportation. I represented Stantec Consulting as the Executive Director for Netweaving and Diversity for our Transportation group; the four pillars of the event aligned with elements of our mission—education, access to jobs, retention, and leadership. Forty years in this industry have armed me with many examples of the successes of and challenges in attracting, retaining, and developing leadership opportunities for bright women.

Another hat I sport is as cochair of the TRB Women's Issues in Transportation Committee. The committee is developing a track on transportation matters that affect women for our April 2014 conference; we also share findings from research on safety and security of transit travel, the impact of technical developments, and other topics with a strong gender consideration.

In my career, I have been the first woman to serve in a number of capacities, and the lessons learned allowed me to be an engaged participant in the leadership track.

Mentorship and sponsorship are vital. Research shows that approximately 50 percent of graduates are women, but at the top, only 3 percent of leadership positions are filled by women. Transportation professionals must be actively and enthusiastically engaged in mentorship—nurturing women to be fully qualified to serve in leadership—and in sponsorship—identifying opportunities and speaking up about strong female candidates.

---

*Turnbull is Executive Associate Director, Texas A&M Transportation Institute, and Chair, TRB Technical Activities Council. Anderson Bomar is Senior Principal, Stantec Consulting, Inc., and Cochair, TRB Women's Issues in Transportation Committee.*



Katherine F. Turnbull, Texas A&M Transportation Institute (above), and Marsha Anderson Bomar, Stantec Consulting, Inc., represented TRB in April at a White House forum.

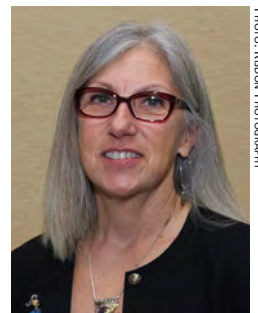





PHOTO: SIEMENS

Amtrak *Cities Sprinter* locomotives will undergo field testing this summer.

## Energy-Efficient Locomotives on Track

Amtrak is adding 70 new electric locomotives to its fleet as part of a comprehensive equipment modernization and expansion plan. Built by Siemens in a renewable-energy powered rail manufacturing plant, the Amtrak *Cities Sprinter* locomotives will operate on Northeast Regional trains at speeds up to 125 mph between Boston, New York, and Washington, D.C., and on Keystone Service trains at speeds up to 110 mph between Philadelphia and Harrisburg, Pennsylvania. All long-distance trains on the Northeast Corridor will be powered by the new locomotives.

The first three units of the \$466-million order will be tested this summer—two at the U.S. Department of Transportation facility in Pueblo, Colorado, and one on the Northeast Corridor—to enter into revenue service in the fall.

The new locomotives meet the latest federal rail safety regulations and are designed for easier maintenance and enhanced mobility. With a regenerative braking system that will feed energy back into the power grid, the units also are energy efficient. They will replace electric loco-

motives that have been in service for 25 to 35 years and that have traveled an average of more than 3.5 million miles.

For more information, see [www.amtrak.com/ccurl/898/720/Amtrak-Siemens-Locomotive-ATK-13-039.pdf](http://www.amtrak.com/ccurl/898/720/Amtrak-Siemens-Locomotive-ATK-13-039.pdf).

## Voice-to-Text Offers Drivers No Safety Advantages

Voice-to-text mobile phone applications offer no safety advantage over manual texting, according to research from the Texas A&M Transportation Institute. Based on the performance of 43 research participants driving an actual vehicle on a closed course, the study is the first of its kind and was sponsored by the Southwest Region University Transportation Center.

Participants first navigated the driving course without the use of cell phones. Each driver then traveled the course three more times, once each using two voice-to-text applications—Siri for the iPhone and Vlingo for Android—and once texting manually. Researchers measured the length of time it took each driver to complete the tasks and to respond to a light that came on at random intervals during the exercises.

According to the study, driver response times were significantly delayed with both texting methods—in each case, the reaction times were approximately twice as long as in a texting-free environment—and both of the texting platforms significantly reduced the amount of time drivers spent looking at the roadway ahead. Although manual texting required slightly less time for most tasks than the voice-to-text method, driver performance suffered by approximately the same amount. Drivers reported feeling less safe when they were texting manually but safer when using a voice-to-text application.

For more information, visit <http://tti.tamu.edu/groups/texting-and-driving>.

## INTERNATIONAL

### New Test Facility Measures Railway Performance

Among the challenges related to the construction and maintenance of high-speed railway infrastructure in Europe, North America, and East Asia is the permanent settlement of ballasted tracks under the strong impact of high-speed trains, leading to greater dynamic interaction between train and track. With higher stability and durability, ballastless slab track is widely used in new high-speed railways. Field observation and laboratory testing, however, are required for further development of ballastless slab track.

Although field measurements provide valuable data on railway behavior under moving loads, extensive field tests are hindered by high costs. Model tests provide a reliable, low-cost alternative.

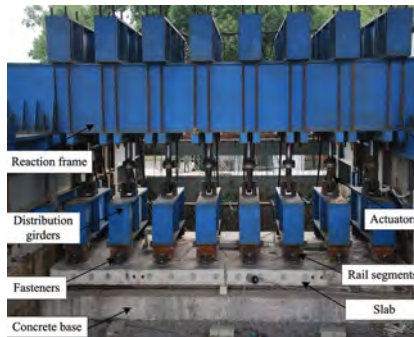

Zhejiang University rail testing facility.

Zhejiang University in Hangzhou, China, has opened a full-scale testing facility for high-speed railways. At the facility, a series of dynamic actuators generates sequential loading on a track structure to simulate a train's passage. Department of Civil Engineering faculty have conducted full-scale model testing of ballastless slab track constructed according to China's high-speed railway design code. Before the Beijing-Shanghai High-Speed Railway was put into commercial operation, the newly built ballastless slab track underwent tests on a full-scale model at the

facility. Field measurements confirmed the accuracy of the model test results.

For more information on the full-scale testing facility at Zhejiang University, contact Xuecheng Bian at [bianxc@zju.edu.cn](mailto:bianxc@zju.edu.cn) or visit [www.ssgo.zju.edu.cn](http://www.ssgo.zju.edu.cn).



### **Planning Sustainable Transport**

Barry Hutton. Routledge, 2013; 430 pp.; \$59.95; 978-18-4971-391-7.

Through a cross-disciplinary overview of transportation systems and their interactions with urban and regional planning decisions and environmental issues,

this volume offers a critique of existing methodology and policy and explores the definitions, trends, problems, objectives, and policies of transportation planning.



### **Underground Engineering for Sustainable Urban Development**

Board on Earth Sciences and Resources; Division on Earth and Life Studies; National Research Council. National Academies Press, 2013; 230 pp.; \$59; 978-03-0927-824-9.

Well-maintained, resilient, and adequately performing underground infrastructure can be an essential part of sustainability, but much remains to be learned about improving the sustainability of underground infrastructure itself. This volume identifies research needs to maximize opportunities for using underground space and enhances understanding of the role of underground engineering in urban sustainability.

The books in this section are not TRB publications. To order, contact the publisher listed.

### **Grand Central: How a Train Station Transformed America**

Sam Roberts. Grand Central Publishing, 2013; 320 pp.; \$30; 978-14-5552-596-6.

The author explores how New York's Grand Central Terminal—now celebrating its 100th anniversary—anticipated the evolution of suburban development and, with the railroad, encouraged westward expansion and growth.

The plans for Grand Central Terminal were catalyzed by a fatal 1902 train crash in the Park Avenue Tunnel that killed 15 passengers. New York Central Railroad chief engineer William J. Wilgus proposed switching to electric trains and replacing the rail yard in the heart of New York City with a luxurious new terminal. In 1903, the railroad's board of directors voted to proceed; the following year, ground broke on the project that would take a decade and \$2 billion in current U.S. dollars to complete.



West balcony of the Grand Central Terminal main concourse, ca. 1910–1920.

Almost with its opening in 1913, Grand Central became a classic Manhattan landmark. Among the amenities provided were separate waiting rooms, shoe-polishing services, dressing rooms, and salons for women; private barbershops for men; and uniformed informational guides, dubbed “walking encyclopedias” in the promotional literature. Iconic features include the opal-faced clock, marble staircases modeled on those at the Paris Opera House, and the celestial ceiling in the main lobby, which has served as a backdrop to several classic film scenes.

Outlined in this illustrated history of the iconic transit hub are the station's conception, history, and its long-lasting cultural effects, along with information about the terminal's role in standardizing time; the debate over AC/DC power for the electric trains; and innovations, such as luggage ramps, that now are taken for granted.



## TRB PUBLICATIONS

### **Statistical Methods and Highway Safety Performance 2012**

Transportation Research Record 2279

Rule-based forecasting of traffic flow, household automobile and motorcycle ownership, quantile effects of causal factors on crash distributions, *Highway Safety Manual* calibration factors, and crash modification factors for changes to left-turn phasing are among the topics examined in this volume.

2012; 131 pp.; TRB affiliates, \$51.75; nonaffiliates, \$69. Subscriber categories: *data and information technology; safety and human factors.*

### **Sustainable Practices, Performance Measures, and Management**

Transportation Research Record 2280

Authors present research on hard highway shoulder running, safety intervention models, real-time safety evaluations, crash avoidance maneuvers, integrating observational and traffic simulation models, crash frequency in work zones, and more.

2012; 191 pp.; TRB affiliates, \$58.50; nonaffiliates, \$78. Subscriber categories: *safety and human factors; data and information technology.*

### **Highway Safety 2012: Traffic Law Enforcement, Alcohol, Occupant Protection, Motorcycles, and Trucks**

Transportation Research Record 2281

Explored are topics including the spatial effectiveness of speed feedback signs, risks of apprehension for speeding in Norway, effects of alcohol on

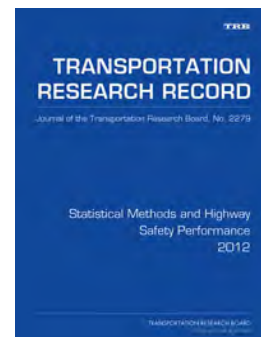

## TRB PUBLICATIONS (continued)

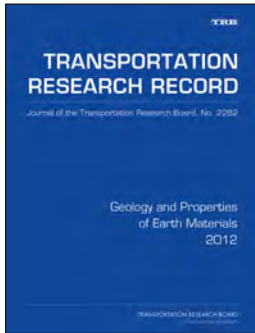

speeding and road positioning, and moped rider violation behavior and moped safety at intersections in China.

2012; 132 pp.; TRB affiliates, \$51.75; nonaffiliates, \$69. *Subscriber categories: safety and human factors; vehicles and equipment.*

**Geology and Properties of Earth Materials 2012**  
Transportation Research Record 2282

Papers on such subjects as a snow melting model for hydronically heated pavement, road milling with diamond-enhanced or tungsten carbide teeth, accelerated pavement testing of uncrushed aggregates in unsurfaced road applications, and emerging technological approaches to analyzing rural highway projects are presented in this volume.

2012; 99 pp.; TRB affiliates, \$46.50; nonaffiliates, \$62. *Subscriber categories: geotechnology; pavements; construction.*

**Network Modeling 2012, Vol. 1**

Transportation Research Record 2283

This volume addresses path-constrained traffic assignment, welfare effects of congestion pricing, an algorithm for intermodal optimal multideestination tours, optimization of school locations in rural areas, the user equilibrium traffic assignment problem, and other topics.

2012; 142 pp.; TRB affiliates, \$51.75; nonaffiliates, \$69. *Subscriber categories: planning and forecasting; security and emergencies.*

**Network Modeling 2012, Vol. 2**

Transportation Research Record 2284

Online activity routing systems, combined distribution–assignment models, design of bike lane networks, schedule-based transit networks, routing behavior for vacant taxicabs, and a stochastic user equilibrium for route choice are among the subjects examined in this volume.

2012; 124 pp.; TRB affiliates, \$48; nonaffiliates, \$64. *Subscriber categories: planning and forecasting; security and emergencies.*

**Travel Survey Methods, Freight Data Systems, and Asset Management 2012**

Transportation Research Record 2285

Authors present research on culvert asset management, transportation investment decisions considering project interdependencies, multimodal trips in travel surveys, measuring future vehicle preferences, freight generation modeling using aggregate data, and more.

2012; 172 pp.; TRB affiliates, \$58.50; nonaffiliates, \$78. *Subscriber category: planning and forecasting.*

**Highway Capacity and Quality of Service 2012**  
Transportation Research Record 2286

The papers in this volume address signal count-down timers, work zone capacity, driver following behavior on two-lane rural highways, recurring freeway bottlenecks, capacity drop in highway merging sections, and more.

2012; 132 pp.; TRB affiliates, \$51.75; nonaffiliates, \$69. *Subscriber categories: operations and traffic management; planning and forecasting.*

**Energy and Global Climate Change 2012**

Transportation Research Record 2287

Explored are such topics as driving distance of electric vehicles, emission reduction technologies for large fleets, carbon footprints for public transportation agencies, and proposed vehicle fuel economy standards in the United States for 2017 to 2025.

2012; 181 pp.; TRB affiliates, \$58.50; nonaffiliates, \$78. *Subscriber categories: energy; environment.*

**Freight Systems 2012**

Transportation Research Record 2288

Traffic at intermodal logistic hubs, varieties of logistics centers, commodity forecasting, modular B-triples, road pricing effects on freight carrier behavior, and shields for safe transport of explosives are among the subjects examined in this volume.

2012; 102 pp.; TRB affiliates, \$46.50; nonaffiliates, \$62. *Subscriber categories: freight transportation; motor carriers; planning and forecasting.*

**Railways 2012**

Transportation Research Record 2289

Authors present research on high-speed rail versus air transportation, risk assessment of positive train control, a portable emission measurement system, track fastenings in high-speed and heavy-haul railroads, asset condition assessment, causes of train derailments, and more.

2012; 163 pp.; TRB affiliates, \$55.50; nonaffiliates, \$74. *Subscriber categories: rail; freight transportation; passenger transportation.*

**Calibration of Rutting Models for Structural and Mix Design**

NCHRP Report 719

Highlighted in this report are proposed revisions to the *Mechanistic–Empirical Pavement Design Guide* (MEPDG) and software to incorporate three alter-

The TRR Journal Online website provides electronic access to the full text of more than 13,000 peer-reviewed papers that have been published as part of the Transportation Research Record: Journal of the Transportation Research Board (TRR Journal) series since 1996. The site includes the latest in search technologies and is updated as new TRR Journal papers become available. To explore the TRR Online service, visit [www.TRB.org/TRROnline](http://www.TRB.org/TRROnline).

## TRB PUBLICATIONS (continued)

native rut-depth prediction models. Also suggested are revisions to MEPDG that would update coefficients for the original and alternative rut-depth transfer functions or prediction models.

2012; 207 pp.; TRB affiliates, \$54.75; nonaffiliates, \$73. Subscriber categories: highways; materials; design.

### **Estimating the Effects of Pavement Condition on Vehicle Operating Costs**

NCHRP Report 720

This report presents models for estimating the effects of pavement condition on vehicle operating costs. The models address fuel consumption, tire wear, and repair and maintenance costs, and are presented as computational software that is included with the print version of the report in a CD-ROM format.

2012; 77 pp.; TRB affiliates, \$48; nonaffiliates, \$64. Subscriber categories: energy; finance; pavements.

### **Fatigue Evaluation of Steel Bridges**

NCHRP Report 721

Detailed examples of proposed revisions to Section 7 of the American Association of State Highway and Transportation Officials' (AASHTO) *Manual for Bridge Evaluation* are presented in this report.

2012; 115 pp.; TRB affiliates, \$45; nonaffiliates, \$60. Subscriber categories: highways; bridges and other structures.

### **Assessing Highway Tolling and Pricing Options and Impacts, Volumes 1 and 2**

NCHRP Report 722

This two-volume report presents a decision-making framework and analytical tools for determining the impact of user-based fees and tolling on revenue generation and system performance of highways.

2012; 379 pp.; TRB affiliates, \$65.25; nonaffiliates, \$87. Subscriber categories: highways; finance; planning and forecasting.

### **Practices to Manage Traffic Sign Retroreflectivity**

NCHRP Synthesis 431

This synthesis presents sample practices that show how different types of transportation agencies can meet federal retroreflectivity requirements for traffic signs.

2012; 44 pp.; TRB affiliates, \$32.25; nonaffiliates, \$43. Subscriber categories: highways; maintenance and preservation; operations and traffic management; public transportation; safety and human factors.

### **Recent Roadway Geometric Design Research for Improved Safety and Operations**

NCHRP Synthesis 432

An update of NCHRP Synthesis 299, this volume reviews and summarizes roadway geometric design literature from the past decade, particularly research that has identified impacts on safety and operations.

2012; 81 pp.; TRB affiliates, \$40.50; nonaffiliates, \$54. Subscriber categories: construction; design; highways; safety and human factors.

### **Significant Findings from Full-Scale Accelerated Pavement Testing**

NCHRP Synthesis 433

Significant findings from various full-scale accelerated pavement testing programs in the past decade are summarized in this volume and are presented along with a survey of knowledge gaps and future research needs.

2012; 154 pp.; TRB affiliates, \$50.25; nonaffiliates, \$67. Subscriber categories: aviation; highways; materials; pavements.

### **Guidebook for Selecting Methods to Monitor Airport and Aircraft Deicing Materials**

ACRP Report 72

This report provides a step-by-step process for identifying, evaluating, and selecting methods for airports to monitor stormwater runoff that may contain deicing materials. Addressed are ways to identify parameters, the appropriateness of various monitoring methods and instruments, and the setup, operation, and maintenance of each method.

2012; 231 pp.; TRB affiliates, \$54; nonaffiliates, \$72. Subscriber categories: aviation; environment.

### **Airport-to-Airport Mutual Aid Programs**

ACRP Report 73

Benefits and issues related to airport-to-airport mutual aid programs are explored in this volume, along with guidelines for establishing agreements with other airports in the event of a communitywide disaster requiring support and assistance beyond one airport's capabilities.

2012; 181 pp.; TRB affiliates, \$53.25; nonaffiliates, \$71. Subscriber category: aviation.

### **Application of Enterprise Risk Management at Airports**

ACRP Report 74

This report summarizes the principles and benefits of applying enterprise risk management (ERM) to airports and implementing the iterative ERM

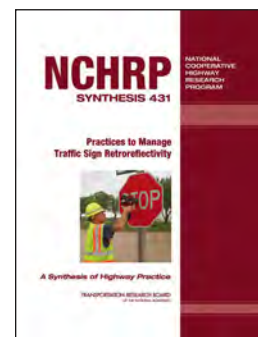

## TRB PUBLICATIONS (continued)



process. An accompanying CD-ROM includes a set of tools for applying ERM.

2012; 63 pp.; TRB affiliates, \$34.50; nonaffiliates, \$46. Subscriber category: aviation.

### Expediting Aircraft Recovery at Airports

ACRP Synthesis 38

Outlined in this synthesis are suggested procedures to help airports expedite the recovery of disabled aircraft, avoiding injury to personnel, damage to airport equipment, and secondary damage to the aircraft.

2012; 100 pp.; TRB affiliates, \$42.75; nonaffiliates, \$57. Subscriber categories: aviation; security and emergencies.

### Improving ADA Paratransit Demand Estimation: Regional Modeling

TCRP Report 158

The sketch planning models and regional models in this report are designed to help metropolitan planning organizations and transit operators in estimating future demand for Americans with Disability Act (ADA) complementary paratransit service and in predicting the numbers of travel-eligible individuals on all public transportation modes. A CD-ROM accompanies.

2012; 96 pp.; TRB affiliates, \$48; nonaffiliates, \$64. Subscriber category: public transportation.

### Transforming Public Transportation Institutional and Business Models

TCRP Report 159

Offered in this volume is a strategy for defining and implementing transformative change in institutional and business models and facilitating the operation and maintenance of public transportation systems.

2012; 73 pp.; TRB affiliates, \$38.25; nonaffiliates, \$51. Subscriber categories: public transportation; administration and management.

### Guidebook for Assessing Evolving International Container Chassis Supply Models

NCFRP Report 20

Through descriptions of historical and evolving models of international container chassis ownership and management in the United States, this volume provides an understanding of salient issues and implications as the chassis supply market continues to evolve.

2012; 85 pp.; TRB affiliates, \$40.50; nonaffiliates, \$54. Subscriber categories: freight transportation; terminals and facilities; vehicles and equipment.

### Handbook on Applying Environmental Benchmarking in Freight Transportation

NCFRP Report 21

With a step-by-step overview and application framework, this report explores how benchmarking can be used as a management tool to promote environmental performance in the freight and logistics industry.

2012; 63 pp.; TRB affiliates, \$36; nonaffiliates, \$48. Subscriber categories: environment; freight transportation.

### A Compendium of Best Practices and Lessons Learned for Improving Local Community Recovery from Disastrous Hazardous Materials Transportation Incidents

HMCRCR Report 9

This report explores how local communities can develop or improve recovery planning and operations in response to hazardous materials transportation incidents.

2012; 186 pp.; TRB affiliates, \$53.25; nonaffiliates, \$71. Subscriber categories: freight transportation; planning and forecasting; security and emergencies.

### Interactions Between Transportation Capacity, Economic Systems, and Land Use

SHRP 2 Report S2-C03-RR-1

Presented in this volume are stakeholder needs, limitations of available tools, and future research; a design for Transportation Project Impact Case Studies; a handbook for practitioners; and economic impact data analysis findings.

2012; 50 pp.; TRB affiliates, \$34.50; nonaffiliates, \$46. Subscriber categories: economics; highways.

### Freight Demand Modeling and Data Improvement

SHRP 2 Report S2-C20-RR-1

This report documents the current state of the practice for freight demand modeling and the data required for effective freight modeling, data collection, and decision making.

2013; 80 pp.; TRB affiliates, \$41.25; nonaffiliates, \$55. Subscriber categories: data and information technology; freight transportation; highways; planning and forecasting.

To order TRB titles described in Bookshelf, visit the TRB online Bookstore, at [www.TRB.org/bookstore/](http://www.TRB.org/bookstore/), or contact the Business Office at 202-334-3213.

## INFORMATION FOR CONTRIBUTORS TO

# TR NEWS

*TR News* welcomes the submission of manuscripts for possible publication in the categories listed below. All manuscripts submitted are subject to review by the Editorial Board and other reviewers to determine suitability for *TR News*; authors will be advised of acceptance of articles with or without revision. All manuscripts accepted for publication are subject to editing for conciseness and appropriate language and style. Authors receive a copy of the edited manuscript for review. Original artwork is returned only on request.

**FEATURES** are timely articles of interest to transportation professionals, including administrators, planners, researchers, and practitioners in government, academia, and industry. Articles are encouraged on innovations and state-of-the-art practices pertaining to transportation research and development in all modes (highways and bridges, public transit, aviation, rail, marine, and others, such as pipelines, bicycles, pedestrians, etc.) and in all subject areas (planning and administration, design, materials and construction, facility maintenance, traffic control, safety, security, logistics, geology, law, environmental concerns, energy, etc.). Manuscripts should be no longer than 3,000 words (12 double-spaced, typed pages). Authors also should provide charts or tables and high-quality photographic images with corresponding captions (see Submission Requirements). Prospective authors are encouraged to submit a summary or outline of a proposed article for preliminary review.

**RESEARCH PAYS OFF** highlights research projects, studies, demonstrations, and improved methods or processes that provide innovative, cost-effective solutions to important transportation-related problems in all modes, whether they pertain to improved transport of people and goods or provision of better facilities and equipment that permits such transport. Articles should describe cases in which the application of project findings has resulted in benefits to transportation agencies or to the public, or in which substantial benefits are expected. Articles (approximately 750 to 1,000 words) should delineate the problem, research, and benefits, and be accompanied by one or two illustrations that may improve a reader's understanding of the article.

**NEWS BRIEFS** are short (100- to 750-word) items of interest and usually are not attributed to an author. They may be either text or photographs or a combination of both. Line drawings, charts, or tables may be used where appropriate. Articles may be related to construction, administration, planning, design, operations, maintenance, research, legal matters, or applications of special interest. Articles involving brand names or names of manufacturers may be determined to be inappropriate; however, no endorsement by TRB is implied

when such information appears. Foreign news articles should describe projects or methods that have universal instead of local application.

**POINT OF VIEW** is an occasional series of authored opinions on current transportation issues. Articles (1,000 to 2,000 words) may be submitted with appropriate, high-quality illustrations, and are subject to review and editing.

**BOOKSHELF** announces publications in the transportation field. Abstracts (100 to 200 words) should include title, author, publisher, address at which publication may be obtained, number of pages, price, and ISBN. Publishers are invited to submit copies of new publications for announcement.

**LETTERS** provide readers with the opportunity to comment on the information and views expressed in published articles, TRB activities, or transportation matters in general. All letters must be signed and contain constructive comments. Letters may be edited for style and space considerations.

**SUBMISSION REQUIREMENTS:** Manuscripts submitted for possible publication in *TR News* and any correspondence on editorial matters should be sent to the Director, Publications Office, Transportation Research Board, 500 Fifth Street, NW, Washington, DC 20001, telephone 202-334-2972, or e-mail [jawan@nas.edu](mailto:jawan@nas.edu).

- ◆ All manuscripts should be supplied in 12-point type, double-spaced, in Microsoft Word, on a CD or as an e-mail attachment.

- ◆ Submit original artwork if possible. Glossy, high-quality black-and-white photographs, color photographs, and slides are acceptable. Digital continuous-tone images must be submitted as TIFF or JPEG files and must be at least 3 in. by 5 in. with a resolution of 300 dpi. A caption should be supplied for each graphic element.

- ◆ Use the units of measurement from the research described and provide conversions in parentheses, as appropriate. The International System of Units (SI), the updated version of the metric system, is preferred. In the text, the SI units should be followed, when appropriate, by the U.S. customary equivalent units in parentheses. In figures and tables, the base unit conversions should be provided in a footnote.

**NOTE:** Authors are responsible for the authenticity of their articles and for obtaining written permissions from publishers or persons who own the copyright to any previously published or copyrighted material used in the articles.

## Rail Resources at the Ready

A multimodal transportation system that links businesses with consumers, suppliers, and markets is critical to the

nation's economy. Rail transportation enables the effective and efficient movement of intercity passengers and connects U.S. consumers with agricultural, economic, logistics, and manufacturing centers throughout the nation and the world. The Transportation Research Board has produced an array of information to help transportation professionals and decision makers enhance the nation's rail transportation system.

Recent publications of interest include the following:

### Railways 2012

*Transportation Research Record: Journal of the Transportation Research Board*, No. 2289, ISBN 978-0-309-22329-4, 163 pages, 8.5 x 11, paperback, \$74, 2012

### Multimodal Freight Transportation Within the Great Lakes–Saint Lawrence Basin

National Cooperative Freight Research Program (NCFRP) Report 17, ISBN 978-0-309-25830-2, 97 pages, 8.5 x 11, paperback, \$57, 2012

### Committee for Review of the Federal Railroad Administration Research, Development, and Demonstration Programs Letter Report

Letter Report, May 31, 2012, 15 pages, 8.5 x 11, [www.trb.org/Main/Blurbs/167226.aspx](http://www.trb.org/Main/Blurbs/167226.aspx), 2012

### Determination of Longitudinal Stress in Rails

Final Report, Safety Innovations Deserving Exploratory Analysis (IDEA) Project 15, 58 pages, 8.5 x 11, <http://onlinepubs.trb.org/Onlinepubs/IDEA/FinalReports/Safety/S15Report.pdf>, 2012

### Teamwork in U.S. Railroad Operations: A Conference

Transportation Research E-Circular E-C159, 136 pages, 8.5 x 11, [www.trb.org/Publications/Blurbs/166401.aspx](http://www.trb.org/Publications/Blurbs/166401.aspx), 2011

### Framework and Tools for Estimating Benefits of Specific Freight Network Investments

NCFRP Report 12, ISBN 978-0-309-21356-1, 123 pages, 8.5 x 11, paperback, \$61, 2011

### Impacts of Public Policy on the Freight Transportation System

NCFRP Report 6, ISBN 978-0-309-21335-6, 103 pages, 8.5 x 11, paperback, \$53, 2011

### Strategies for Improving the Project Agreement Process Between Highway Agencies and Railroads

Second Strategic Highway Research Program Report S2-R16-RR-1, ISBN 978-0-309-12888-9, 8.5 x 11, 174 pages, paperback, \$66, 2010

### Guidebook for Implementing Passenger Rail Service on Shared Passenger and Freight Corridors

National Cooperative Highway Research Program Report 657, ISBN 978-0-309-15470-3, 169 pages, 8.5 x 11, paperback, \$60, 2010



## THE NATIONAL ACADEMIES™

Advisers to the Nation on Science, Engineering, and Medicine

The nation turns to the National Academies—National Academy of Sciences, National Academy of Engineering, Institute of Medicine, and National Research Council—for independent, objective advice on issues that affect people's lives worldwide.

[www.national-academies.org](http://www.national-academies.org)



NATIONAL ACADEMY OF SCIENCES

1863–2013 • Celebrating 150 Years of Service to the Nation

