



## Resource Manual for Airport In-Terminal Concessions

### DETAILS

---

258 pages | | PAPERBACK

ISBN 978-0-309-21353-0 | DOI 10.17226/13326

### AUTHORS

---

BUY THIS BOOK

FIND RELATED TITLES

Visit the National Academies Press at [NAP.edu](http://NAP.edu) and login or register to get:

---

- Access to free PDF downloads of thousands of scientific reports
- 10% off the price of print titles
- Email or social media notifications of new titles related to your interests
- Special offers and discounts



Distribution, posting, or copying of this PDF is strictly prohibited without written permission of the National Academies Press. (Request Permission) Unless otherwise indicated, all materials in this PDF are copyrighted by the National Academy of Sciences.

Copyright © National Academy of Sciences. All rights reserved.

AIRPORT COOPERATIVE RESEARCH PROGRAM

---

---

**ACRP REPORT 54**

---

---

**Resource Manual for Airport  
In-Terminal Concessions**

LEIGH FISHER  
Burlingame, CA

IN ASSOCIATION WITH  
EXSTARE FEDERAL SERVICES GROUP, LLC  
Alexandria, VA

*Subscriber Categories*

Administration and Management • Aviation • Finance • Terminals and Facilities

---

Research sponsored by the Federal Aviation Administration

---

**TRANSPORTATION RESEARCH BOARD**

WASHINGTON, D.C.  
2011  
[www.TRB.org](http://www.TRB.org)

## AIRPORT COOPERATIVE RESEARCH PROGRAM

Airports are vital national resources. They serve a key role in transportation of people and goods and in regional, national, and international commerce. They are where the nation's aviation system connects with other modes of transportation and where federal responsibility for managing and regulating air traffic operations intersects with the role of state and local governments that own and operate most airports. Research is necessary to solve common operating problems, to adapt appropriate new technologies from other industries, and to introduce innovations into the airport industry. The Airport Cooperative Research Program (ACRP) serves as one of the principal means by which the airport industry can develop innovative near-term solutions to meet demands placed on it.

The need for ACRP was identified in *TRB Special Report 272: Airport Research Needs: Cooperative Solutions* in 2003, based on a study sponsored by the Federal Aviation Administration (FAA). The ACRP carries out applied research on problems that are shared by airport operating agencies and are not being adequately addressed by existing federal research programs. It is modeled after the successful National Cooperative Highway Research Program and Transit Cooperative Research Program. The ACRP undertakes research and other technical activities in a variety of airport subject areas, including design, construction, maintenance, operations, safety, security, policy, planning, human resources, and administration. The ACRP provides a forum where airport operators can cooperatively address common operational problems.

The ACRP was authorized in December 2003 as part of the Vision 100-Century of Aviation Reauthorization Act. The primary participants in the ACRP are (1) an independent governing board, the ACRP Oversight Committee (AOC), appointed by the Secretary of the U.S. Department of Transportation with representation from airport operating agencies, other stakeholders, and relevant industry organizations such as the Airports Council International-North America (ACI-NA), the American Association of Airport Executives (AAAE), the National Association of State Aviation Officials (NASAO), and the Air Transport Association (ATA) as vital links to the airport community; (2) the TRB as program manager and secretariat for the governing board; and (3) the FAA as program sponsor. In October 2005, the FAA executed a contract with the National Academies formally initiating the program.

The ACRP benefits from the cooperation and participation of airport professionals, air carriers, shippers, state and local government officials, equipment and service suppliers, other airport users, and research organizations. Each of these participants has different interests and responsibilities, and each is an integral part of this cooperative research effort.

Research problem statements for the ACRP are solicited periodically but may be submitted to the TRB by anyone at any time. It is the responsibility of the AOC to formulate the research program by identifying the highest priority projects and defining funding levels and expected products.

Once selected, each ACRP project is assigned to an expert panel, appointed by the TRB. Panels include experienced practitioners and research specialists; heavy emphasis is placed on including airport professionals, the intended users of the research products. The panels prepare project statements (requests for proposals), select contractors, and provide technical guidance and counsel throughout the life of the project. The process for developing research problem statements and selecting research agencies has been used by TRB in managing cooperative research programs since 1962. As in other TRB activities, ACRP project panels serve voluntarily without compensation.

Primary emphasis is placed on disseminating ACRP results to the intended end-users of the research: airport operating agencies, service providers, and suppliers. The ACRP produces a series of research reports for use by airport operators, local agencies, the FAA, and other interested parties, and industry associations may arrange for workshops, training aids, field visits, and other activities to ensure that results are implemented by airport-industry practitioners.

## ACRP REPORT 54

Project 01-11

ISSN 1935-9802

ISBN 978-0-309-21353-0

Library of Congress Control Number 2011937761

© 2011 National Academy of Sciences. All rights reserved.

### COPYRIGHT INFORMATION

Authors herein are responsible for the authenticity of their materials and for obtaining written permissions from publishers or persons who own the copyright to any previously published or copyrighted material used herein.

Cooperative Research Programs (CRP) grants permission to reproduce material in this publication for classroom and not-for-profit purposes. Permission is given with the understanding that none of the material will be used to imply TRB or FAA endorsement of a particular product, method, or practice. It is expected that those reproducing the material in this document for educational and not-for-profit uses will give appropriate acknowledgment of the source of any reprinted or reproduced material. For other uses of the material, request permission from CRP.

### NOTICE

The project that is the subject of this report was a part of the Airport Cooperative Research Program, conducted by the Transportation Research Board with the approval of the Governing Board of the National Research Council.

The members of the technical panel selected to monitor this project and to review this report were chosen for their special competencies and with regard for appropriate balance. The report was reviewed by the technical panel and accepted for publication according to procedures established and overseen by the Transportation Research Board and approved by the Governing Board of the National Research Council.

The opinions and conclusions expressed or implied in this report are those of the researchers who performed the research and are not necessarily those of the Transportation Research Board, the National Research Council, or the program sponsors.

The Transportation Research Board of the National Academies, the National Research Council, and the sponsors of the Airport Cooperative Research Program do not endorse products or manufacturers. Trade or manufacturers' names appear herein solely because they are considered essential to the object of the report.

*Published reports of the*

### AIRPORT COOPERATIVE RESEARCH PROGRAM

*are available from:*

Transportation Research Board  
Business Office  
500 Fifth Street, NW  
Washington, DC 20001

*and can be ordered through the Internet at*

<http://www.national-academies.org/trb/bookstore>

Printed in the United States of America

# THE NATIONAL ACADEMIES

## *Advisers to the Nation on Science, Engineering, and Medicine*

The **National Academy of Sciences** is a private, nonprofit, self-perpetuating society of distinguished scholars engaged in scientific and engineering research, dedicated to the furtherance of science and technology and to their use for the general welfare. On the authority of the charter granted to it by the Congress in 1863, the Academy has a mandate that requires it to advise the federal government on scientific and technical matters. Dr. Ralph J. Cicerone is president of the National Academy of Sciences.

The **National Academy of Engineering** was established in 1964, under the charter of the National Academy of Sciences, as a parallel organization of outstanding engineers. It is autonomous in its administration and in the selection of its members, sharing with the National Academy of Sciences the responsibility for advising the federal government. The National Academy of Engineering also sponsors engineering programs aimed at meeting national needs, encourages education and research, and recognizes the superior achievements of engineers. Dr. Charles M. Vest is president of the National Academy of Engineering.

The **Institute of Medicine** was established in 1970 by the National Academy of Sciences to secure the services of eminent members of appropriate professions in the examination of policy matters pertaining to the health of the public. The Institute acts under the responsibility given to the National Academy of Sciences by its congressional charter to be an adviser to the federal government and, on its own initiative, to identify issues of medical care, research, and education. Dr. Harvey V. Fineberg is president of the Institute of Medicine.

The **National Research Council** was organized by the National Academy of Sciences in 1916 to associate the broad community of science and technology with the Academy's purposes of furthering knowledge and advising the federal government. Functioning in accordance with general policies determined by the Academy, the Council has become the principal operating agency of both the National Academy of Sciences and the National Academy of Engineering in providing services to the government, the public, and the scientific and engineering communities. The Council is administered jointly by both Academies and the Institute of Medicine. Dr. Ralph J. Cicerone and Dr. Charles M. Vest are chair and vice chair, respectively, of the National Research Council.

The **Transportation Research Board** is one of six major divisions of the National Research Council. The mission of the Transportation Research Board is to provide leadership in transportation innovation and progress through research and information exchange, conducted within a setting that is objective, interdisciplinary, and multimodal. The Board's varied activities annually engage about 7,000 engineers, scientists, and other transportation researchers and practitioners from the public and private sectors and academia, all of whom contribute their expertise in the public interest. The program is supported by state transportation departments, federal agencies including the component administrations of the U.S. Department of Transportation, and other organizations and individuals interested in the development of transportation. [www.TRB.org](http://www.TRB.org)

[www.national-academies.org](http://www.national-academies.org)



# COOPERATIVE RESEARCH PROGRAMS

## **CRP STAFF FOR ACRP REPORT 54**

**Christopher W. Jenks**, *Director, Cooperative Research Programs*  
**Crawford F. Jencks**, *Deputy Director, Cooperative Research Programs*  
**Michael R. Salamone**, *ACRP Manager*  
**Theresa H. Schatz**, *Senior Program Officer*  
**Joseph J. Brown-Snell**, *Program Associate*  
**Eileen P. Delaney**, *Director of Publications*  
**Ellen M. Chafee**, *Editor*

## **ACRP PROJECT 01-11 PANEL**

### **Field of Administration**

**Carl E. Remus**, *Tulsa Airport Authority, Tulsa, OK* (Chair)  
**John A. Buckner, Jr.**, *Salt Lake City Department of Airports, Salt Lake City, UT*  
**Zenola Worrill Campbell**, *Dallas/Fort Worth International Airport, DFW Airport, TX*  
**Alan M. Gluck**, *Broward County (FL) Aviation Department, Ft. Lauderdale, FL*  
**Raymond Moore**, *Delta Airlines, Inc., Atlanta, GA*  
**Michael R. Mullaney**, *The Hudson Group, East Rutherford, NJ*  
**M. Ashraf Jan**, *FAA Liaison*  
**Danielle J. Rinsler**, *AICP, FAA Liaison*  
**Liyang Gu**, *Airports Council International–North America Liaison*  
**Christine Gerencher**, *TRB Liaison*

## **AUTHOR ACKNOWLEDGMENTS**

The research reported herein was performed under ACRP Project 01-11, “Understanding Airport In-Terminal Concession Programs.” LeighFisher (formerly Jacobs Consultancy) was the contractor for this study, with Exstare Federal Services Group, LLC, as a subcontractor.

Bruce J. Boudreau, Director of LeighFisher, was the Project Director and Principal Investigator. Gary J. Davies, Associate Director of LeighFisher, and Gordon Hamilton, Director of LeighFisher, served as Deputy Principal Investigators. Other authors of this report are Francois Martel, Director of LeighFisher; David J. Biggs, Director of LeighFisher; Nancy K. West, Principal, Exstare Federal Services Group, LLC; and Linda Moore, Principal, Animer Consulting, LLC.

The Research Team would like to express its gratitude to the members of the project panel for their support and insightful comments throughout this research project. The Research Team would also like to thank the many airport staff, concessionaire representatives, consultants, and overseas airport commercial managers who took the time to share their insights, experience, and opinions with the Research Team and to respond to follow-up queries.



# FOREWORD

By **Theresia H. Schatz**

Staff Officer

Transportation Research Board

*ACRP Report 54: Resource Manual for Airport In-Terminal Concessions* provides guidance on the development and implementation of airport concession programs. The report provides information on the airport concession process; concession goals; potential customers; developing a concession space plan and concession mix; the Airport Concessions Disadvantaged Business Enterprise (ACDBE) program; and concession procurement, contracting, and management practices. Case studies are provided to illustrate key areas. This report will help airport managers understand market potential and implementation requirements for an effective in-terminal concession program while recognizing evolving challenges. This report will serve as a valuable tool for use by airport staff involved in and responsible for the business decisions affecting the development of concession programs and plans. It also serves as an informational tool for other stakeholders, including but not limited to, airport board members, airlines involved in creating concession programs, and concessionaires. In-terminal concessions are defined as food and beverage, retail, amenities, and services (e.g., vending, banking, luggage carts, postal services, telephones and wireless communications, advertising, and personal services).

---

Airport in-terminal concessions provide an important and necessary passenger service amenity and have been shown to be a key contributor to overall passenger satisfaction. A well-implemented concession program can also provide measurable financial benefits to the airport's operating budget. Requirements for design and delivery of these services have changed dramatically over the past 10 years as services have moved inside the secure environment. In addition, as passengers continue to spend more time inside the secure terminal area, meeting changing needs has become even more important. As a result, many airports have transformed their retail and service offerings from generic non-branded food and news and a predictable set of services into an integrated set of offerings featuring national and regional food concepts, a wide variety of specialty retail brands, and services tailored to both meet and stimulate passenger needs. With these changes, there is a greater need to understand the market potential and challenges as well as a variety of viewpoints (e.g., domestic and international airports, other retail, transportation centers, and other commercial venues).

A report documenting the research method used to develop the resource manual has been posted on the ACRP Project 01-11 web page at <http://apps.trb.org/cmsfeed/TRBNetProjectDisplay.asp?ProjectID=2571>. This research effort was conducted by Leigh Fisher as the prime contractor with Bruce Boudreau serving as the Principal Investigator in association with Exstare Federal Services Group, LLC.



# CONTENTS

<b>1</b>	<b>Chapter 1 Introduction to Airport In-Terminal Concessions</b>
1	1.1 Changes in Airport In-Terminal Concession Programs
2	1.2 Purpose of the Resource Manual
2	1.3 Methodology and Data Collection
4	1.4 Potential Benefits of the Resource Manual
5	1.5 Navigating the Resource Manual
<b>6</b>	<b>Chapter 2 Overview of Airport Concession Programs</b>
6	2.1 Revenues from In-Terminal Concessions
10	2.2 Types of In-Terminal Concessions
16	2.3 Attributes of Successful Concession Programs
18	2.4 Recent Trends in Concessions
<b>22</b>	<b>Chapter 3 Establishing Goals for the Concession Program</b>
22	3.1 Competing Stakeholder Demands
24	3.2 Concession Program Planning Process
25	3.3 Assessment of Customer Satisfaction
27	3.4 Establishment of Realistic Expectations
28	3.5 Differences between Domestic and International Passengers and Terminals
34	3.6 Optimization of Sales and Revenues
34	3.7 Preparation of a SWOT Analysis
35	3.8 Common Concession Program Goals
<b>40</b>	<b>Chapter 4 The Passenger and Customer Profile</b>
40	4.1 The Airport and Its Customers
41	4.2 Passenger Segments
42	4.3 Other Customer Segments
46	4.4 Demographics and Market Segmentation
47	4.5 Identifying Gaps—Why Certain Market Segments Do Not Patronize Concessions
47	4.6 Customer Surveys and Focus Groups
<b>52</b>	<b>Chapter 5 Developing the Concession Space Plan</b>
52	5.1 Space Planning
65	5.2 Supportable Concession Units Based on Traffic Levels
66	5.3 Sizing of Concession Units
66	5.4 Location Criteria
71	5.5 Adjacencies
72	5.6 International Terminals
73	5.7 Wayfinding and Concession Signage
73	5.8 Return on Airport Investments in Concession Space
<b>79</b>	<b>Chapter 6 The Concession Mix</b>
79	6.1 Achieving the Right Overall Balance
81	6.2 Program Differentiation and Creating a Sense of Place

82	6.3 Concession Theming
83	6.4 Branded Concessions
85	6.5 Food and Beverage Concession Category
87	6.6 Convenience Retail
88	6.7 Specialty Retail
88	6.8 Duty Free
90	6.9 Services
92	6.10 Advertising
<b>104</b>	<b>Chapter 7 The ACDBE Program</b>
104	7.1 Federal Requirements
107	7.2 Determining Concessionaire Market Area(s)
107	7.3 Determining Availability of Ready, Willing, and Able Participants
108	7.4 Establishing Race-Neutral and Race-Conscious Participation Goals
109	7.5 Outreach Activities
111	7.6 Methods for Achieving ACDBE Participation through Contractual Arrangements
113	7.7 Evaluating Joint Venture and Subtenant Agreements
114	7.8 Compliance Monitoring and Enforcement
114	7.9 Attributes of Successful ACDBE Programs
115	7.10 Measuring Performance
116	7.11 Reporting Achievements
116	7.12 Barriers to ACDBE Participation
119	7.13 Program Audits
119	7.14 Mentoring
<b>121</b>	<b>Chapter 8 Concession Contracting Approaches</b>
121	8.1 Description of Concession Management Approaches
128	8.2 Financial Performance by Management Approach
<b>137</b>	<b>Chapter 9 Business Terms and Concession Agreements</b>
137	9.1 Term
139	9.2 Privileges
140	9.3 Concession Fees
145	9.4 Obligations
148	9.5 Performance Standards
149	9.6 Pricing
151	9.7 Capital Improvements
152	9.8 Midterm Investment Requirements
152	9.9 Other Concession Agreement Provisions
153	9.10 Business Practices in Need of Review
153	9.11 Additional Concession Agreement Resources
<b>155</b>	<b>Chapter 10 Procurement</b>
155	10.1 Concession Procurement Approaches
158	10.2 Requests for Proposals—the Standard Practice
160	10.3 Minimum Qualifications
160	10.4 Typical Elements Required in Proposals
162	10.5 Evaluation Criteria
163	10.6 Financial Evaluation
165	10.7 Advertising the RFP
165	10.8 Issuing the RFP
166	10.9 The Preproposal Conference
167	10.10 The Evaluation Process

167	10.11	Converting the Proposal to a Concession Agreement
168	10.12	Streamlining the RFP
169	10.13	Concession Workforce Issues
170	10.14	Strategies for Increasing Local Participation
171	10.15	Using Technology to Streamline the Solicitation Process
172	10.16	International Concession Contracting Practices
<b>173</b>		<b>Chapter 11 Services, Storage, and Logistics</b>
173	11.1	Loading Docks
175	11.2	Security Screening of Goods
176	11.3	Concession Storage Facilities
177	11.4	Servicing Routes and Devices
178	11.5	Use of Centralized Third-Party Logistics Providers
180	11.6	Waste Collection, Recycling, and Removal
185	11.7	Sustainability
187	11.8	Food Preparation
<b>188</b>		<b>Chapter 12 Capital Investment</b>
188	12.1	Cost of Building on the Airport
188	12.2	Investment Relative to Sales
191	12.3	Midterm Investment
191	12.4	Design Guidelines and Standards
199	12.5	Permitting and Monitoring Buildout
<b>200</b>		<b>Chapter 13 Managing the Concession Program</b>
200	13.1	Staffing Requirements and Qualifications
201	13.2	Lease Management Systems
201	13.3	Understanding the Concession Agreement
202	13.4	Importance of Comprehensive Concession Agreement Files
203	13.5	Interaction with Concessionaires
204	13.6	Marketing the Concession Program
206	13.7	Organizing the Concession Staff
207	13.8	Performance Monitoring
213	13.9	Reconcepting Existing Units
213	13.10	Transition Planning
214	13.11	Airports with Well-Managed Concession Programs
<b>216</b>		<b>Chapter 14 Case Studies</b>
216	14.1	Dallas/Fort Worth International Airport
222	14.2	San Francisco International Airport
227	14.3	Tulsa International Airport
232	14.4	Portland International Airport
236	14.5	Amsterdam Schiphol International Airport
240	14.6	Seoul Incheon International Airport
244	14.7	Copenhagen International Airport
<b>248</b>		<b>Glossary</b>
<b>252</b>		<b>References</b>
<b>253</b>		<b>Bibliography</b>

---

Note: Many of the photographs, figures, and tables in this report have been converted from color to grayscale for printing. The electronic version of the report (posted on the Web at [www.trb.org](http://www.trb.org)) retains the color versions.

# Introduction to Airport In-Terminal Concessions

*ACRP Report 54: Resource Manual for Airport In-Terminal Concessions* is the end product of ACRP Project 11-01, “Understanding Airport In-Terminal Concession Programs.” This introductory chapter provides general background information, presents the methodology used to develop this resource manual, discusses its potential benefits, and outlines its organization. Lastly, the use of icons intended to help the reader navigate through the manual is discussed.

## 1.1 Changes in Airport In-Terminal Concession Programs

The evolution of airports from rudimentary airfields to today’s sophisticated centers of commercial transportation is paralleled by the development of in-terminal concession programs at airports.

In the opinion of airport concession managers interviewed for this project, in-terminal concession programs have over the years gained a higher profile and become more important contributors to the financial and operational success of today’s airports. Developing and managing in-terminal concession programs requires the application of sound commercial practices adapted to the unique constraints of airport terminals, an understanding of the needs of passengers, and an understanding of the public procurement requirements under which individual airports operate.

The rapid growth in airline travel following World War II was characterized by a highly regulated airline industry and a growing need for new, modern terminals and airfield capacity. The introduction of jet aircraft in the late 1950s made airline travel faster and more convenient, and required further expansion of airfields and terminals. While the need for new investment was great, airports at that time were unproven credit risks. To support the required new investment, airport sponsors turned to long-term lease and use agreements with the airlines and long-term concession agreements, often exclusive, which provided guaranteed revenues over the life of the agreements.

Airline deregulation in the late 1970s resulted in new startup airlines, expanded airline service, cheaper airfares, and rapid growth in numbers of passengers, followed by a significant period of terminal expansion. Major new terminals at the airports serving Atlanta, Dallas/Fort Worth, Denver, Phoenix, and Pittsburgh, among others, were planned to accommodate the expansion of airline hub-and-spoke route systems. The terminals at airports in other cities were expanded to meet current and forecast demand.

Also, in the 1970s, a few forward-leaning airport sponsors, such as those overseeing Washington National and Miami International airports, introduced branded concessions to supplement the

large contracts that characterized the airport industry at that time. Operators of other airports, including Portland International Airport, successfully brought local brands to the airport.

Federal mandates to expand opportunities for minority businesses were introduced in the 1980s, and airport sponsors restructured concession agreements to provide opportunities for Minority Business Enterprises (MBEs, later changed to Disadvantaged Business Enterprises, or DBEs), adding to the scope of existing concession programs.

Over time, airport sponsors became less reliant on revenue guarantees and more concerned with improving the food and beverage, retail, and service concessions offered to passengers. The reduced reliance on exclusive contracts and long-term guaranteed revenues—based on a realization that the local market, and not individual airlines, was the driver of passenger demand—brought an end to the belief that passengers were a “captive market” most efficiently and profitably exploited by a few long-term concession agreements. From a contracting perspective, the award of concession agreements evolved from straight bids based solely on guaranteed revenues toward more customer-focused processes emphasizing customer satisfaction and convenience as well as revenue. Passengers showed clear preferences for concessions that more closely resembled their choices outside the airport.

In 1992, the new Pittsburgh International Airport terminal opened with a concession program run by a developer, BAA USA, a subsidiary of the U.K. airport operator BAA plc, the privately owned successor to the former British Airports Authority. Allegheny County, operator of the airport, and the hub airline, US Airways, wanted a new, sophisticated concession program that would help attract connecting passengers and make the airport more competitive with other hub airports. The Pittsburgh concession program featured international, national, and local brands and a major commitment to specialty retail. The program was a big success and marked a turning point in the evolution of in-terminal concessions. Soon, traditional concessionaires were embracing branding and offering portfolios of brands.

The increased competition and ease of market entry that led to the expansion of airline service and new airlines also put the older legacy carriers under financial pressure. Increased competition and excess capacity left these airlines vulnerable to economic downturns. Airlines pushed airport sponsors to reduce their rates and charges in the short term and to decrease their reliance on airline rates and charges by growing nonairline revenues. As a result, airport managers became even more focused on improving their concession programs.

Once considered ancillary services that offered basic passenger conveniences, in-terminal concessions have increased in importance as airport sponsors seek to increase nonairline revenues while meeting higher passenger expectations. Fortunately, there is a direct connection between the two.

## **1.2 Purpose of the Resource Manual**

The purpose of this resource manual is to provide airport concession managers and other stakeholders, such as airport senior management, board members, concessionaires, and airlines, with an easy-to-use reference for understanding, planning, evaluating, managing, and developing airport in-terminal concession programs.

## **1.3 Methodology and Data Collection**

Data to support the findings and recommended practices in this resource manual were collected through several means including a literature review and surveys.



### 1.3.1 Literature Review

An extensive survey of recent literature was conducted to determine the overall depth and breadth of available information. While numerous industry presentations and association publications are available in the literature, few scholarly works or in-depth articles on the subject of airport concessions exist. Events and trends in the industry press have received considerable coverage, albeit at a general level. Much of the material is, at its core, promotional material, providing information on recent improvements, successes, or innovations. While considerable information is available on the broader categories of food and beverage, retail, and advertising, a good portion of the literature does not take into account the unique nature of airports. The scale of airport concession programs has grown steadily; however, airport concessions represent a tiny fraction of the broader categories of, say, food and beverage or retail.

Information was also obtained from Airports Council International-North America (ACI-NA) and the American Association of Airport Executives (AAAE).

### 1.3.2 Survey of Concession Managers and Other Practitioners

To support the development of this resource manual, a two-tiered interview program was developed to gather detailed information from concession managers and other practitioners on the state of the industry and current management and business practices. First, a web-based survey was conducted targeting commercial managers at large, medium, and small hub U.S. airports, as well as at nonhub U.S. airports. This survey included questions related to the characteristics of current concession programs, the types of concessions currently offered, business terms, and contracting practices. Questions were also structured to identify what airport concession managers thought were the airport sponsors' goals for the concession programs, and the priorities used in planning and contracting. A total of 49 concession managers responded to the web survey.

A similar, although less extensive, web survey was forwarded to a group of concessionaires, ranging from large national companies to regional and local concession operators. The focus of this survey was capture this group's views on current concession practices at airports and the issues that they believe are important going forward. A total of nine concessionaires participated in this web survey.

Other survey groups included airline representatives responsible for concession programs in airline terminals, a concession-planning consultant, and several concession managers at overseas airports. Follow-up oral interviews were also conducted with most of the participants in the web surveys.

For a variety of reasons, airports outside the United States have long had larger and more sophisticated concession programs. To identify differences between U.S. and non-U.S. airports, particularly those with well-developed concession programs, the research team supplemented the literature search with oral interviews of concession managers at five non-U.S. airports. The research team also interviewed executives from companies that operate concessions in sports venues and on university campuses to compare and contrast business practices.

References to "the survey" in this resource manual pertain to the web surveys and interviews conducted for this research project, unless otherwise specified in the text.

### 1.3.3 Use of Financial and Other Data in the Resource Manual

Financial data, the basis for commonly used metrics such as sales per enplaned passenger and revenue per enplaned passenger, change each year. Over the long term, concession sales at most



airports generally grow at a rate at or above the rate of inflation. During most of the first decade of this century, sales and revenue per enplanement grew at a pace well above the rate of inflation save for the recession and other changes following the attacks of September 11, 2001, and, in particular, the world financial crisis and economic downturn that began in late 2008. These economic downturns affected each airport differently, but in most cases, materially.

Airports that are expanding terminals, implementing new concession programs, or making changes to their existing programs can show significant improvement from one year to the next. Changes in airline service can also have a dramatic effect on concession performance, on the airport as a whole, at a terminal, or within a terminal. For these reasons, the user is encouraged to use the most current data when benchmarking against comparable airports or considering changes to concession programs.

The user is encouraged to use the financial data, and to a lesser extent, space-related data included in this resource manual as relative indicators. This resource manual is not intended to serve as a repository of current sales and revenue data. Financial reports, often available on airport websites or the Airport Revenue News Annual Fact Books, can provide current data that are useful for benchmarking and other analyses.

It is hoped that this resource manual will be updated from time to time to reflect the current state of the industry. However, the data included in any update will lose their currency shortly after publication, and the user will be encouraged to obtain current data.

## **1.4 Potential Benefits of the Resource Manual**

This resource manual reflects current practices in the industry. The underlying purpose of this research project is to create a document that has practical value for practitioners in the field of airport concessions. It is intended that this resource manual will offer a number of potential benefits, including the following:

- Helping airport concession managers and others in the field understand the differences among airports and how these differences affect concession programs.
- Helping airport concession managers and their staffs understand the rationale for many of the industry practices currently in use.
- Helping those involved in airport concession programs recognize opportunities for improvement and potential solutions to problems by applying the techniques and practices included in this resource manual.
- Providing a primer for small businesses looking to adapt their food and beverage, retail, or service business to meet the demands of the airport operating environment, thereby improving and increasing the range of potential concession offerings available at airports.

It has been said, “If you’ve seen one airport, you’ve seen one airport.” Each airport can be characterized according to multiple variables, all of which affect the development and management of concession programs. Passenger numbers, the airline mix, terminal configuration, passenger demographics, and many other factors have shaped the long-term decisions of concession managers, airport executives, and airport board members.

With the exception of a few large cities with multiple airports, each commercial airport in the United States operates under a different set of state and local legal requirements that apply to airport contracting practices and concession agreements. Therefore, generalizing about best practices or preferred approaches must be done with caution, as some practices may not be feasible, appropriate, or even legal in all situations.

## 1.5 Navigating the Resource Manual

This resource manual is intended for use by a wide range of stakeholders, including elected officials and other policymakers, concessionaires, airport executives, concession managers, and others involved in supporting the development and management of airports. Each potential user of the resource manual will have different needs. For this reason, the following icons are used to assist in finding material that is relevant to each user’s needs:

- The “thinker” icon denotes content that provides an introduction to the topic for readers with limited familiarity with the topic or for nonpractitioners looking for a general introduction to the subject.
- The “windsock” icon highlights content that is suggested reading because it may challenge commonly held assumptions about practices at an individual airport.
- The “checkmark” icon denotes recommended practices that have been established and are widely used in the industry.
- The “asterisk” icon denotes alternative practices used at some airports. These practices are not necessarily recommended, but are provided to reflect current practices in the industry.





## CHAPTER 2

# Overview of Airport Concession Programs



This chapter provides an overview of revenues from in-terminal concession programs at U.S. airports; an introduction to the major types of in-terminal concessions, all of which are addressed in greater detail in later chapters of this resource manual; and a summary of recent trends and events that have shaped today's airport concession programs.

### 2.1 Revenues from In-Terminal Concessions

Although numbers of enplaned passengers at our nation's airports have been volatile at times, airports and concessionaires have benefited from generally steady long-term growth in numbers of enplaned passengers, along with real growth in concession spending. This section presents an overview of traffic growth at U.S. airports, aeronautical and nonaeronautical revenue sources, and average passenger spending at U.S. terminal concessions.

#### 2.1.1 Traffic Growth

Over the last four decades, the numbers of enplaned passengers on U.S. airlines have grown, on average, in 4 out of every 5 years. Since 1970, numbers of U.S. enplaned passengers have increased fourfold, at an average annual growth rate of 3.7%. In 2009, U.S. commercial enplaned passengers totaled 695 million, about 8.8% lower than the all-time high of 762 million in 2007.

In-terminal concession revenue correlates strongly with changes in passenger traffic. Figure 2-1 illustrates the long-term growth in numbers of U.S. enplaned passengers since 1970. Over this period, growth in passenger traffic was interrupted five times by recessions, wars, and the terrorist attacks of September 11, 2001. Although growth in passenger traffic is occasionally disrupted by macroeconomic events, the recovery periods are typically short, and positive growth has returned relatively quickly. Of the five instances when year-over-year passenger traffic declined, in only three instances did the downturns extend for more than 2 consecutive years. This record of positive traffic and revenue growth has attracted strong interest in airports by potential concessionaires, as well as service providers, lenders, and investors.

#### 2.1.2 Airport Revenue Sources—Aeronautical and Nonaeronautical

Airport revenues are classified by the FAA as either aeronautical or nonaeronautical. "Aeronautical revenues" generally refers to revenues from the use of airfields, aircraft aprons, and airline terminal buildings. "Nonaeronautical revenues" generally refers to revenues from other activities, including passenger-related sources, such as parking, rental cars, and terminal concessions, and nonpassenger-related sources, such as commercial ground leases, sale of mineral

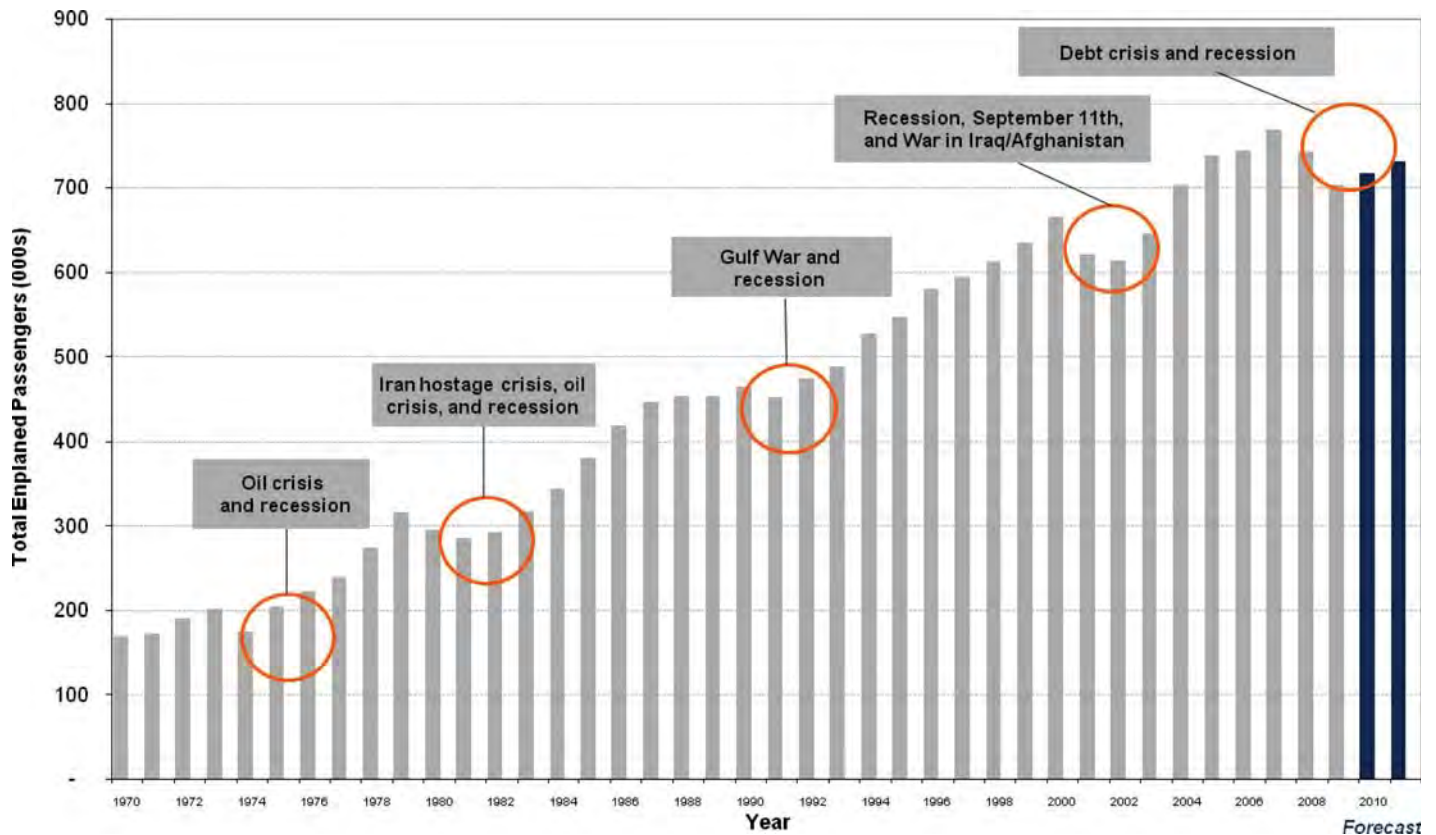

Sources: Air Transport Association of America 2011. FAA Forecast and Performance Analysis Division 2010, Table S-10, p. 22.

**Figure 2-1. Enplaned passengers per year since 1970.**

rights, or other revenue-producing activities. Figure 2-2 shows the split between aeronautical and nonaeronautical revenues for all U.S. commercial service airports (i.e., airports with at least one scheduled airline aircraft operation per day). The data are for 2009, as extracted from the FAA Compliance Activity Tracking System (CATS) reports filed by each airport operator (FAA n.d.). Airport operating revenues totaled nearly \$15.7 billion in 2009. Of this amount, nearly \$6.7 billion, or 43%, came from nonaeronautical sources.

Figure 2-2 also shows revenue from in-terminal concessions, which account for, on average, about 21% of total nonaeronautical revenues. In-terminal concession revenue, as reported to the FAA, total \$1,408 million and include revenues from food and beverage (\$465 million); retail, including duty free (\$570 million); and services (\$373 million). These amounts represent payments to the airport sponsors from concessionaires and other service providers. The FAA does not provide a separate breakout for retail excluding duty free.

The contribution from nonaeronautical revenues varies widely among airports and depends on a number of factors, including the following:

- Availability of land for commercial or other nonaeronautical uses
- Distance from the major population centers and availability of alternate forms of ground transportation, which can affect demand for automobile parking and rental cars
- Passenger demographics, which can affect spending
- Numbers of international passengers, which can produce duty free and higher overall retail spending
- Time spent in the terminals by passengers (also referred to as dwell time), which can also affect spending

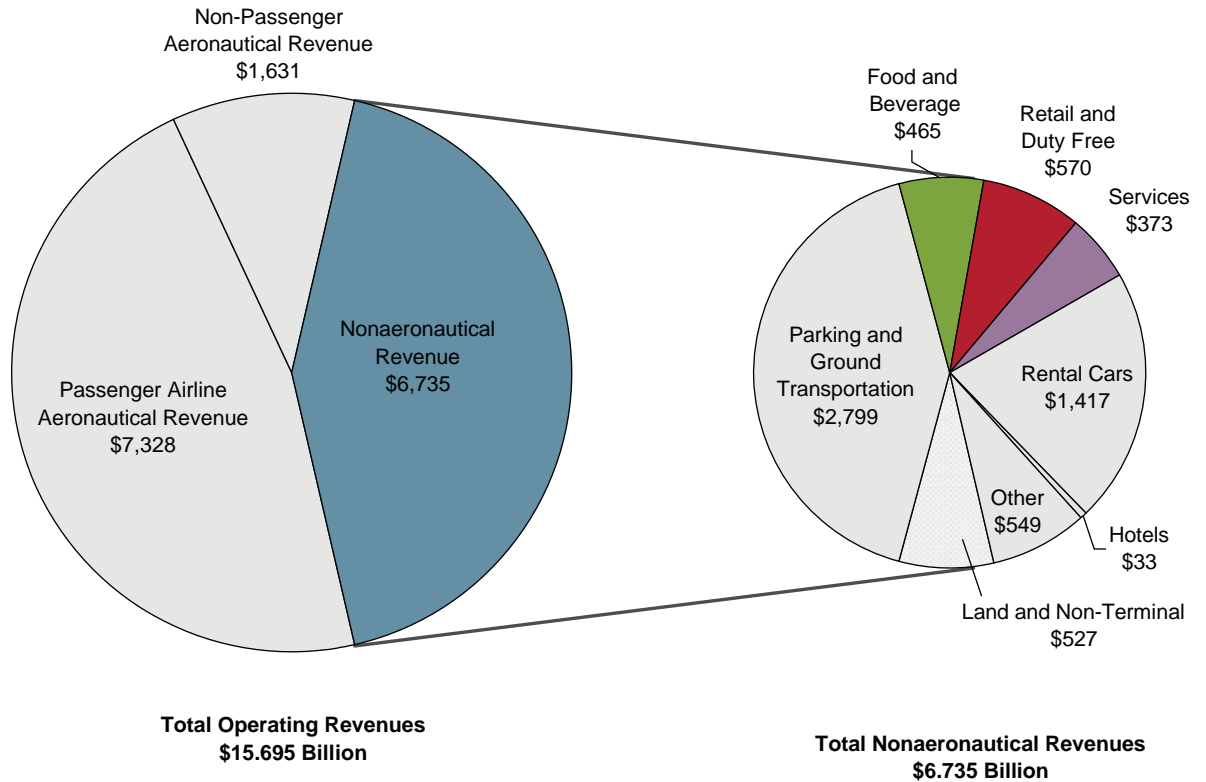

Source: FAA n.d.

**Figure 2-2. Total 2009 operating and nonaeronautical revenues for all U.S. commercial service airports (dollars in millions).**

- Terminal configuration, which can dictate concession space layouts and sales performance
- Airport management practices and emphasis on developing nonaeronautical revenues
- Other factors unique to each airport

Figure 2-3 shows the variation in the percentage of nonaeronautical revenues for a representative group of airports in 2008 based on FAA CATS Report 127 filings by airport operators (FAA n.d.). The cost of providing new and expanded terminal and airfield facilities may result in higher airline charges, therefore lowering the share of nonaeronautical revenues, which can account for as much as 85% of total revenues (at Richmond International Airport) and as little as 33% of total revenues (at Chicago O’Hare International Airport).

Based on 2009 data reported to the FAA, on average, small hub airports earn 54% of their operating revenues from nonaeronautical sources. This percentage decreases to 49% for medium hub airports and to 40% for large hub airports.



Figure 2-4 shows the shares of total U.S. terminal concession revenue according to airport hub status. Terminal concession revenue tends to decline with passenger activity levels, reflecting the economies of scale of larger airports. The 30 airports classified as large hubs accounted for 80% of total terminal concession revenue and about 70% of total U.S. airline passengers in 2009. The 38 airports classified as medium hubs accounted for about 14% of total terminal concession revenue and about 19% of total passengers. The 68 small hub airports accounted for 5% of total terminal concession revenue and about 8% of passengers. The 383 nonhub commercial service airports accounted for only 1% of terminal concession revenue and about 3% of total airline passengers.



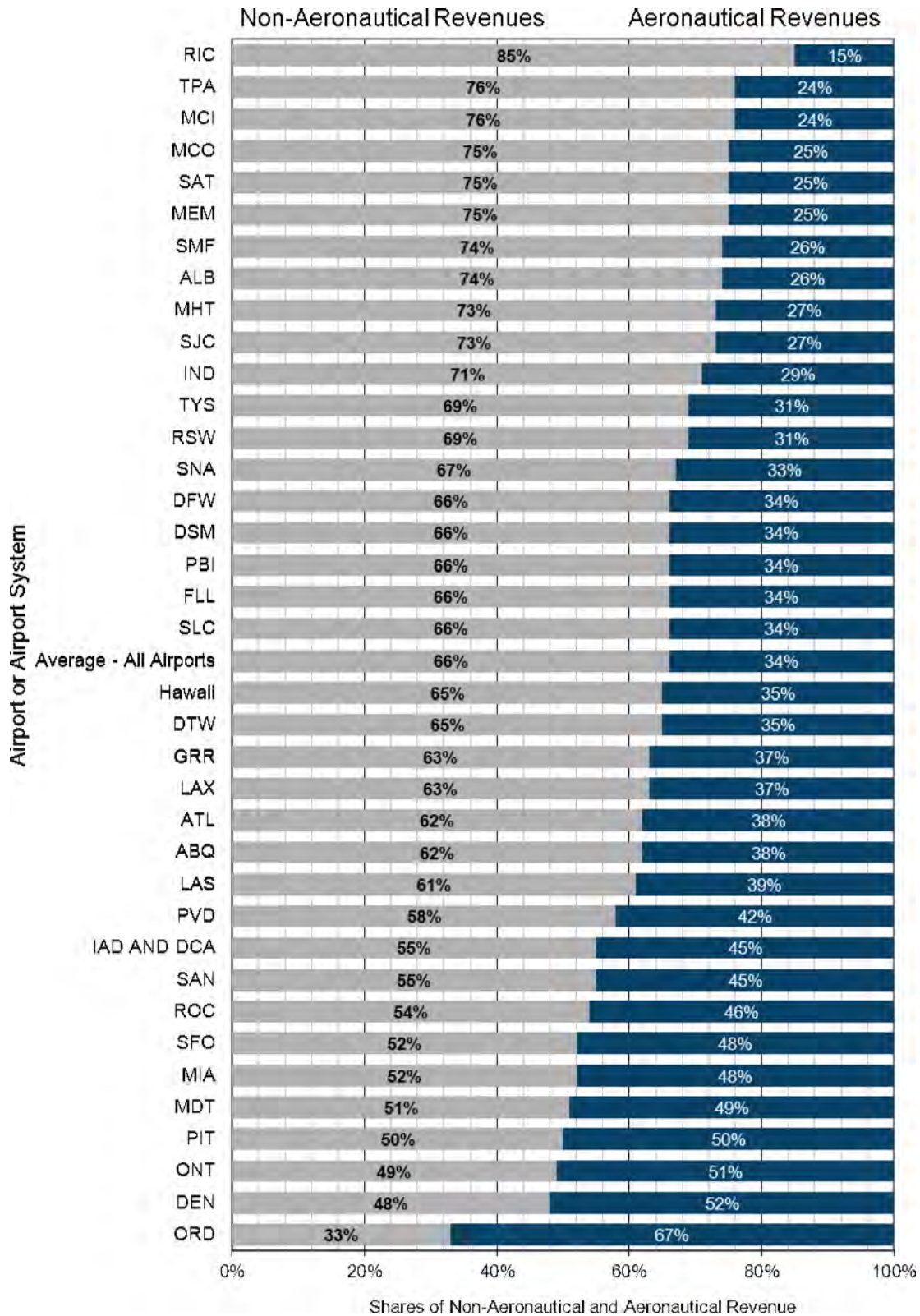

Source: Jacobs Consultancy, Inc., 2008, Table 8, p. 51. Data are for 2008 as reported by individual airports on FAA CATS Report 127 (FAA n.d.).

**Figure 2-3. Nonaeronautical revenues as a percentage of total revenues for selected airports and airport systems—FY2008.**

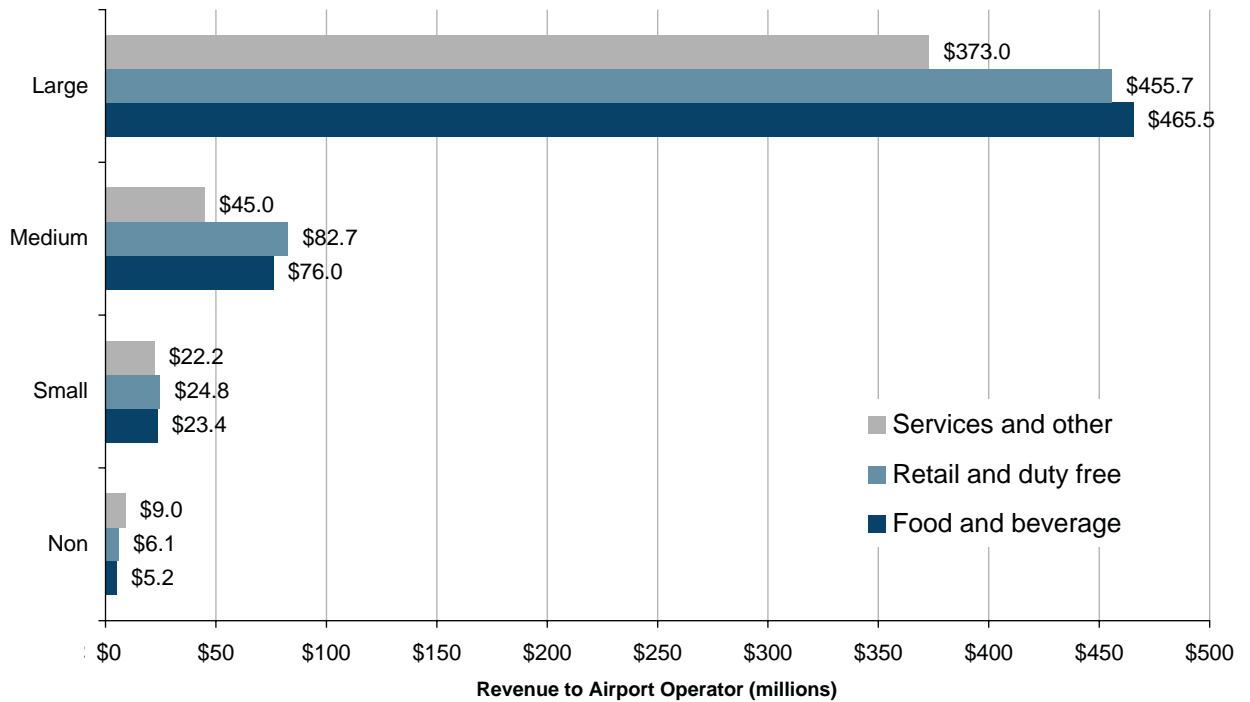

Source: FAA Compliance Activity Tracking System (CATS) Reports as of December 4, 2010 (FAA n.d.).

**Figure 2-4. Total 2009 concession revenues by category and airport hub size (dollars in millions).**

Figure 2-5 shows the changes in concession revenues at all U.S. commercial service airports by major FAA hub category between 2000 and 2009. After the downturn in traffic in 2002 following the attacks on September 11, 2001, there were six straight years of growth until 2009 and the global recession. Between 2001 and 2009, the services category grew by 157%. Food and beverage and retail revenues grew 24% and 23%, respectively.

### 2.1.3 Average Passenger Spending

In 2008, passenger spending on food and beverage, specialty retail, convenience retail, and duty free averaged \$7.77 at small hub airports, \$7.66 at medium hub airports, and \$15.97 at large hub airports. Figure 2-6 presents a summary of 2008 concession performance by category and by hub size.

## 2.2 Types of In-Terminal Concessions

The number, type, and variety of concessions vary by airport. The major categories of in-terminal concessions discussed in this resource manual are food and beverage, convenience retail, specialty retail, duty free, advertising, and services.



### 2.2.1 Food and Beverage

At U.S. airports, food and beverage concessions generally occupy the most space and are the most productive in terms of sales and revenue. Food and beverage concessions typically occupy approximately 60% of concession space, although the total amount of concession space varies widely. Food and beverage concessions at large hub, medium hub, and small hub airports average 4.5 square feet, 6.5 square feet, and 10.4 square feet of space per 1,000 passengers,

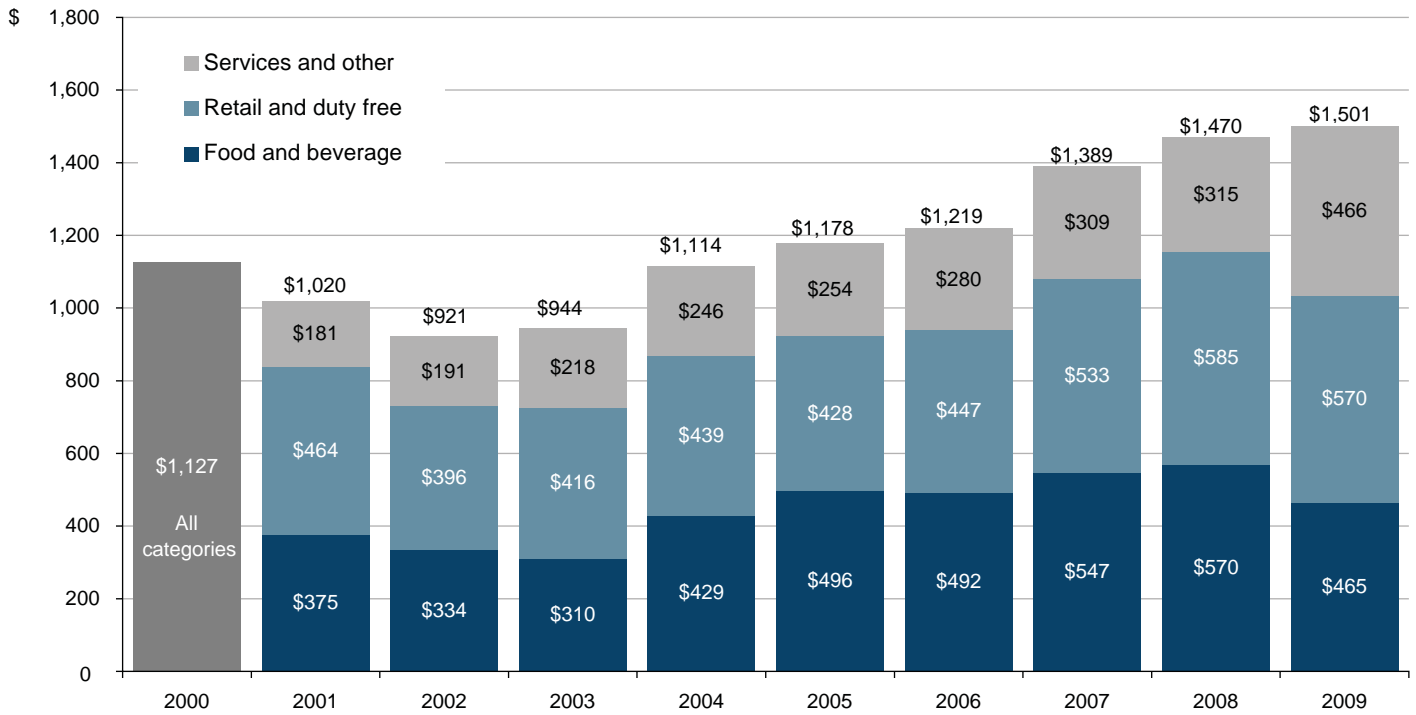

Source: FAA Compliance Activity Tracking System (CATS) Form 127 Reports for years indicated (FAA n.d.).

Figure 2-5. Changes in concession revenues at all U.S. commercial service airports 2000–2009 (dollars in millions).

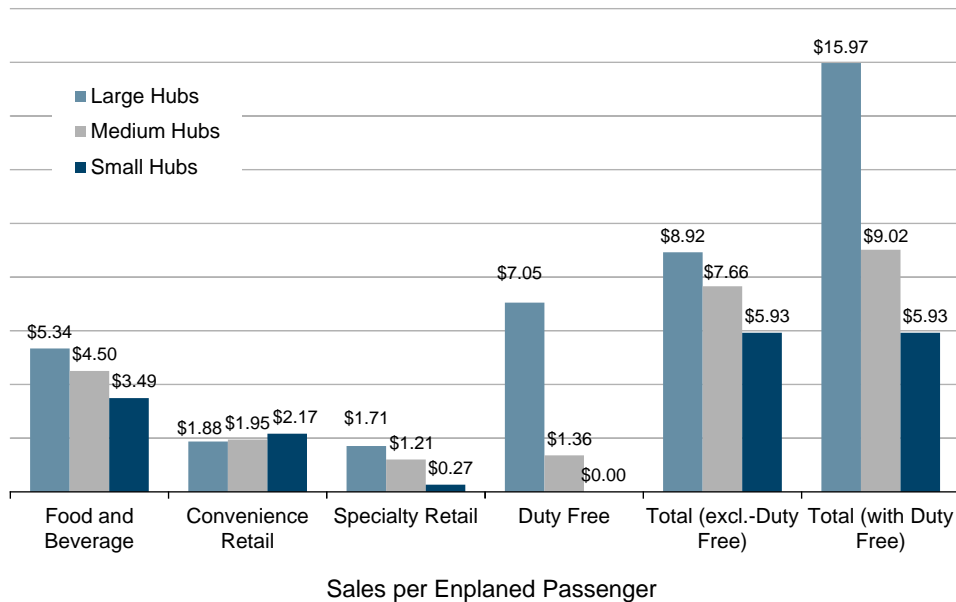

Source: Airport Revenue News 2009. Data are for 2008.

Figure 2-6. 2008 average concession sales per enplaned passenger by category and hub size.



respectively. The range of food and beverage space varies between 2 square feet and 10 square feet per 1,000 enplaned passengers at large and medium hub airports and between 4 square feet and as much as 17 square feet at small hub airports (with one small hub reporting 26 square feet per 1,000 enplaned passengers).

The types of food and beverage services offered at airports generally include the following:

- **Casual dining restaurants** offering meals, snacks, and full bar service, typically with wait staff and table service.
- **Quick-serve** (also called quick-casual) units offering specialized meals, snacks, and nonalcoholic beverages, typically using counter service. Quick-serve is the broadest service category and may include snack concepts (ice cream, frozen yogurt, cookies, and generic snack bars) and Mexican, Asian, sandwich, delicatessen, pizza, hamburgers, and many other concepts. Quick-serve units are often co-located in food courts where they share customer seating and back-of-house facilities and create a major destination for food and beverage services.
- **Bars** offering a full range of alcoholic beverages, as well as snacks and light meals, using wait staff or counter service.
- **Specialty coffee** units offering premium coffee and espresso drinks, tea, pastries, juices, and, in most cases, packaged sandwiches and salads.

The number of primary passenger routes of travel through the terminal (i.e., flows) leading to departure gates and the volume of passengers in each separate flow are major determinants regarding the number of concession units that can be supported.



At many airports, food and beverage services are considered the most important concession from a customer service standpoint. Unlike specialty retail or duty free, which are discretionary purchases, food and beverage services are a necessity for many passengers and achieve the highest sales penetration by passengers. According to multiple surveys at airports by Airport Interviewing and Research, a survey research company, 73% of passengers on average make purchases at concessions. Of these, 68% make a food and beverage purchase, 25% make a newsstand purchase, and 11% make a specialty retail purchase. Some passengers make purchases in multiple categories. Food and beverage concessions are also used by airport employees more than any other concession. The operators of some airports, such as Fort Lauderdale-Hollywood and Sacramento airports, encourage concessionaires to offer employee discounts by assessing a lower percentage rent on sales to employees.

### 2.2.2 Convenience Retail

Convenience retail includes traditional airport retail concepts such as newsstands and news/gift shops, as well as newer hybrid retail concessions, such as convenience stores. Convenience retail concessions offer a merchandise mix that has few parallels outside of transportation terminals.

Newsstands are the most ubiquitous convenience retail concession, offering a merchandise mix centered on a large assortment of newspapers, magazines, and hardback and paperback books. Other newsstand merchandise typically includes sundries, candies, mints, gum, cigarettes and tobacco, health and beauty aids, traveler conveniences, and a range of souvenirs and general merchandise.



News/gift shops are larger, traditional airport retail units that offer newsstand merchandise, but devote a significant amount of overall space to souvenirs, gifts, packaged foods, and general merchandise. Although they are still the dominant form of airport retail concession, news/gift shops at larger airports have been supplemented by specialty shops.

Most airport operators allow convenience retail units to offer bottled water, juices, and other cold beverages as a passenger convenience. A recent addition to the convenience retail category is the convenience store, offering typical newsstand merchandise along with snacks, delicatessen items, and cold and hot beverages. The convenience store concept serves as a “one-stop shop” that can provide the time-limited passenger with the most often purchased items in a single transaction.

According to a national concessionaire surveyed for this project, 15% to 45% of airport passengers typically make a purchase at some type of convenience retail concession.

### 2.2.3 Specialty Retail

Specialty retail refers to a retail shop offering a specialized line of merchandise, such as jewelry, leather goods, personal care products, luggage, gadgets, travel accessories, sports apparel, shoes, cosmetics, regional arts and crafts, clothing, toys, candy/chocolates, or other merchandise. Specialty retail includes in-line shops as well as kiosks, retail merchandise units (RMUs), carts, and, more recently, sophisticated vending machines. Specialty kiosks and RMUs are often branded and may include established national and international brands, local brands, and some airport-only brands.

Specialty retail shops require greater numbers of passengers and, depending on the concept, certain types of passengers. Surveys have shown that less than one-quarter of airport passengers visit specialty retail shops, with only 10% to 15% of passengers making a purchase at such shops.

In-line specialty retail shops tend to be smaller than newsstands or news/gift shops, typically between 500 square feet and 900 square feet, although some concepts may support up to 1,300 square feet of space. In addition to in-line shops, specialty retail kiosks are an important part of the retail program at airports, where concession space is limited. Specialty retail kiosks may range in size from 200 square feet to 450 square feet and can be located along walls within circulation corridors of concourses.

Figure 2-7 shows an example of specialty retail kiosks at Oakland International Airport. The kiosks are located across from a row of food and retail concessions bordering the circulation corridor and holdroom space. The airport operator used the kiosks to provide an expanded retail offering and create a dynamic concession cluster featuring a food court, a newsstand, a Mexican casual dining/bar restaurant, and the specialty retail kiosks.



**Figure 2-7. Specialty retail kiosks at Oakland International Airport.**

### 2.2.4 Duty Free

Duty free shops are retail shops that mainly sell high-end luxury goods in five traditional core categories: perfumes and cosmetics, liquor, tobacco, fashion, and candy/chocolates/confectionery. Duty free shops, with some exceptions, sell merchandise that is free of import duties, excise taxes, and local and state sales taxes. Sales are, by law, limited to departing international passengers.



Merchandise to be sold is purchased by a duty free operator directly from manufacturers and suppliers rather than through normal distribution channels, such as regional wholesalers and distributors, thus avoiding wholesale markups. Merchandise is delivered “in-bond,” that is, in sealed containers under the supervision of Customs authorities. The combination of direct purchase from manufacturers and tax and duty free status results in large gross margins, which translates into attractive pricing for customers, particularly on expensive luxury goods. Airport operators share in these high margins through high guaranteed and variable percentage rents.

Depending on the size of the market and the nationalities and preferences of the international passengers, the duty free operator may also provide branded luxury boutiques or branded shop-in-shop displays featuring men’s and women’s fashion items, gourmet foods, single-malt scotch, or other luxury goods.

The value proposition for duty free shops varies with the customers’ nationalities. Passengers from countries with high import duties, high sales taxes, or value-added taxes (VATs) or countries that levy high excise taxes on certain luxury items are most likely to find duty free shopping attractive. Generally, passengers from Europe and, in particular, Asia come from high-tax environments and are avid duty free customers. Customers from Asia also tend to be very brand conscious and are heavy consumers of branded luxury goods.

The difference in the international passenger mix at airports can make a material difference in duty free sales and revenue. Duty free sales for U.S. East Coast airports averaged about \$8.50 per enplaned international passenger in 2008, while duty free sales at U.S. West Coast airports with higher percentages of passengers from Asia averaged just over \$13.00 per enplaned international passenger.

Outside the United States, major international airports, such as Dubai International, London Heathrow, and Seoul Incheon International airports, produce duty free sales approaching \$1 billion annually because of their large volumes of international passengers, limited domestic traffic, and airline service to high-tax, high-duty destinations.

### 2.2.5 Advertising

In-terminal advertising includes traditional static airport advertising displays such as wall posters, backlighted wall displays, wall wraps, and large-format displays.



Other advertising media in airports may include interior and exterior loading bridge wall wraps, ads on luggage cart panels, banners and column wraps, and dynamic displays including flat-panel monitors, video projection systems, and displays with alternating, changeable printed media. The development of light-emitting diode (LED) displays, such as those used as high-definition video walls in sports stadiums, is providing new opportunities to create free-form, custom displays capable of dynamic graphics and video. Figure 2-8 shows a large and dramatic wall wrap at a highly trafficked area in the terminal at Munich airport.

Airport operators have also implemented nontraditional advertising strategies including airport advertiser-based, closed-circuit audio programming (in-terminal radio); advertising-supported television in holdrooms, such as the CNN Airport Channel; manufacturer-sponsored



**Figure 2-8.** Example of large format airport advertising display at Munich Airport.

televisions in holdrooms, such as the sponsored Samsung displays that usually offer local programming; sponsored childrens' play areas; sponsored business centers; and naming rights arrangements, such as exclusive pouring rights for soft drink companies.

Advertising using wall wraps within loading bridges is also becoming common and, in many cases, can provide advertisers with access to passengers travelling to a specific destination when the assignment of departure gates is well established.

In-terminal advertising is mostly managed by a few specialist companies; however, some airport operators use local out-of-home advertising contractors, and the operator of at least one airport, Jacksonville International Airport in Florida, manages its advertising program in-house.

## 2.2.6 Services

Services include a variety of amenities and personal services for passengers, such as the following:

- Automated teller machines (ATMs), usually provided through a bank, although sometimes installed in airports by commercial vendors.
- Baggage storage services, where luggage can be stored for a few hours or a few days. Lockers are also available in some airports, although security regulations have restricted their use.
- Business centers offering express delivery pickup, copying, printing, computer use, and other business services.
- Foreign exchange kiosks, booths, or in-line units offering currency exchange services, sale of travelers' checks, and cash advances on credit cards.
- Game rooms offering coin- or token-operated video games. Changes in technology, availability of home and portable gaming devices, and noise concerns have reduced the viability of these machines in airports.
- Hair salons and barber shops.
- Internet kiosks.
- Luggage carts, which in the United States are usually offered on a pay basis. Free use of carts is offered in the international arrivals areas of some airports. Internationally, luggage carts are most often provided for free by the airport operator and carry paid advertising.
- Luggage wrapping, where suitcases are covered with clear plastic for protection, and luggage shipping, mainly for international passengers as an alternative to paying excess airline baggage charges.
- Massage services and spas offering a variety of massages, manicures, pedicures, facials, and other spa services. Figure 2-9 shows a typical spa unit at San Francisco International Airport.
- Medical clinics, offering urgent care to passengers, prescriptions for travelers in need, and general medical services to employees. Medical clinics may also provide employment and FAA





Source: San Francisco Airport Commission.

**Figure 2-9. Spa concession at San Francisco International Airport.**

flight physical examinations, treat work-related injuries on behalf of airport employers, administer drug screening tests, administer flu shots and vaccinations, and provide other services.

- Pay telephones. Demand for pay telephone services has declined dramatically with the popularity of cell phones, but are still a necessary service for many passengers.
- Postal services, including the sale of postage, express mail, mailboxes, mail drops, and other postal services. At larger airports, a service center may be staffed by the U.S. Postal Service.
- Shoeshine stands.
- Wi-Fi, which was first offered on a pay basis, but is now offered by many airport operators through sponsorships or as a free service.

The availability of these services will depend upon such factors as the layout of the terminal building, numbers of passengers, and availability of suitable locations. Airports with efficient layouts and concentrated passenger flows are best able to offer a broad range of services. Clustering services together can make them easier for passengers to find.

### 2.3 Attributes of Successful Concession Programs

The profile of airport concessions has increased steadily over the years. Passenger surveys show that concessions, which are used by more than half of all passengers, are an important factor in evaluating the overall passenger experience of the airport. The highest-rated airports in the United States and around the world all have highly regarded concession programs.

The 2009 ACI World Airport Service Quality passenger survey, a voluntary, fee-based program administered by ACI, which involves surveys of passengers around the world, ranked Seoul Incheon International, Singapore Changi, Hong Kong International, Beijing Capital International, and Ghandi Hyderabad International airports as the best airports worldwide (Airports Council International 2010). All of these airports have well-regarded concession programs.

In North America, the airports serving Austin, Halifax, Ottawa, Jacksonville, and Portland, Maine were ranked as the best airports in terms of their well-regarded concession programs. The ACI-World 2009 Airport Service Quality Index award winners are shown on Table 2-1 (Airports Council International 2010).



**Table 2-1. ACI World 2009 airport service quality index award winners.**

<b>BEST AIRPORTS WORLDWIDE</b>	
1. Incheon (ICN)	
2. Singapore (SIN)	
3. Hong Kong (HKG)	
4. Beijing (PEK)	
5. Hyderabad (HYD)	
<b>BEST AIRPORT BY SIZE OF AIRPORT</b>	
<b>Fewer than 5 million passengers</b>	<b>5 – 15 million passengers</b>
1. Halifax (YHZ)	1. Hyderabad (HYD)
2. Ottawa (YOW)	2. Austin (AUS)
3. Portland (PWM)	3. Cancun (CUN)
4. Guayaquil (GYE)	4. Nagoya (NGO)
5. Jackson (JAN)	5. Jacksonville (JAX)
<b>15 – 25 million passengers</b>	<b>25 – 40 million passengers</b>
1. Baltimore/Washington (BWI)	1. Incheon (ICN)
2. Taipei (TPE)	2. Singapore (SIN)
3. Shenzhen (SZX)	3. Tokyo Narita (NRT)
4. New Delhi (DEL)	4. Kuala Lumpur (KUL)
5. Salt Lake City (SLC)	5. Shanghai Pudong (PVG)
<b>Over 40 million passengers</b>	
1. Hong Kong (HKG)	
2. Beijing (PEK)	
3. Denver (DEN)	
4. Dallas Fort Worth (DFW)	
5. Houston George Bush (IAH)	

Source: Airports Council International 2010.

Successful concession programs share a number of key attributes.

- **Aesthetics.** Successful concession programs are characterized by concession units that are contemporary in design, visually interesting, built with durable high-quality materials, and inviting to potential customers, and that complement the terminal building and surroundings.
- **Capacity.** The ability to meet customer demand during seasonal and daily peaks affects customer service and revenues. The peak demand characteristics of airports vary and must be taken into account in planning the concession program.
- **Customer service.** Most purchases are discretionary. Passengers do not travel to the airport to shop or eat. Providing helpful customer service is important to maximizing sales and encouraging multiple purchases.
- **Revenue production.** Revenue production is a principal objective of any concession program. However, airports with successful concession programs have demonstrated that revenue production is not an end in itself; rather, it is the result of successfully incorporating multiple attributes into the concession program and providing passengers with an array of concession choices that meets their needs.
- **Sense of place.** Successful concession programs often reflect the unique attributes of their city and region, offering passengers from other places a brief look into the local community and culture. Whether it is barbecue in Memphis, Cuban food in Miami, seafood in Seattle, or beignets in New Orleans, concession programs benefit by offering local favorites. Bringing in successful local food and retail concepts and incorporating local materials and design aesthetics can also help create a sense of place that differentiates the airport from others.

- **Value.** Historically, value for money has not always been a widely held attribute of airport concession programs, with some airport operators allowing concessionaires to charge customers what the market will bear. Airport operators have adopted a variety of pricing policies, ranging from true “street pricing” to no pricing policy at all. While pricing is important, it is not the only component of creating value for customers.
- **Variety.** Passengers want choices in food and beverage, retail, and services. The broader the range of choices, the more likely it is that the customer will find something he or she wants, and the more likely it is that the concessionaire will achieve higher sales and that the airport operator will have higher revenues.
- **The “wow” factor.** Passengers spend considerable time in airports, and concessions provide choices on how to use that time. Concessions that are unique, visually interesting, and exciting add to the overall passenger experience.

## 2.4 Recent Trends in Concessions



In recent years, a number of broad trends have helped shape the current state of in-terminal concession programs. These trends include the following:

- **Raised expectations.** As airport operators improve their concession programs, frequent travelers including elected officials, members of the media, civic leaders, and other influential residents, will naturally compare airports they visit with their home airport. As concession programs have become larger, more developed, and more successful, the attention they receive in airport industry publications, the business press, and the general media has increased.
- **Decline in airline meal service.** With changes in airline competition, particularly the rise of low-cost carriers (LCCs), airlines have reduced costs—including limiting free meal service—to remain price competitive. The decline in free meal service has increased demand for in-terminal food and beverage services, including food that can be taken aboard the aircraft and enjoyed in-flight. Airlines compete for this business with in-flight snack and meal sales, but the offerings are limited compared with what can be offered within terminals.
- **Healthy, fresh food.** Airport operators have responded to changes in customer demand for fresher, healthier foods by adjusting their concession mix to include freshly prepared foods, including foods cooked or prepared to order within concession units, often in sight of the customer. At the same time, the use of centralized commissary food preparation has declined. Passengers have embraced good, fresh food and rewarded concessionaires and airports that have emphasized quality and diversity in their food and beverage offerings. In the 1990s, offerings at airports were expanded to include more branded foods, including fast foods. While traditional fast food brands still have a place at airports, fresher, higher quality concepts that respond to the preferences of passengers seeking better or healthier foods are also being offered.
- **Local and regional brands and concepts.** According to the survey conducted for this research project, about 29% of the food and beverage brands at airports are local or regional, while about 26% of specialty retail brands are local or regional. Another 10% of newsstands carry the name of a local or national newspaper or magazine, a news or business television network, or a local television station.
- **Local and national “celebrity” chefs.** Recent competitive proposals for airport food offerings have spurred a rise in food and beverage concepts that are licensed or created by celebrity chefs made popular through cable food networks. Kathy Casey, Todd English, Masaharu Morimoto, Wolfgang Puck, and Martin Yan are a few of the well-known chefs who have created successful restaurant concepts for airports. Similarly, cable television’s Food Network and the Culinary Institute of America have partnered with airport concessionaires to create new and unique food and beverage offerings.
- **Smaller leasing packages, more concession agreements.** As airport concessions have grown in scale and sophistication, airport operators have sought to increase the level of competition

and attract a broader range of concession concepts to their airports. To effect this change, the operators of larger airports are awarding multiple concession agreements and using more direct leasing to improve their concession mixes and attract high-quality specialist tenants.

- **Branding.** For passengers, travel involves a series of decisions and risks, and brands are a way of minimizing the risk of a poor decision while in the airport. Passengers have indicated a strong preference for the proven and familiar. Brands can also provide a proven, built-in quality control system with external monitoring that reduces the airport operator's risk of substandard operations. For example, brands with off-airport locations can be used as a benchmark for ensuring that prices are consistent with the pricing policy at the airport.
- **Kiosks, retail merchandise units (RMUs), and wall-huggers.** With airport concession space often constrained by the needs of airlines, many airport operators are incorporating RMUs or kiosks in their concession programs as a means to increase revenues, expand the concession offering, and provide services in underserved areas of the terminal. For example, at Hartsfield-Jackson Atlanta International Airport, retail and food and beverage RMUs have been installed on concourses where passenger demand exceeds the supply of concession space. Wall huggers, a form of RMU that takes minimal floor space and stands against an available wall, are also effective in space-constrained airports.
- **Less time pre-security.** Online check-in and self-service check-in terminals have decreased the time passengers spend in pre-security areas, allowing them to proceed directly to the security checkpoint.
- **Increased security checkpoint processing times.** Although automation is reducing the time passengers spend at ticket counters, they are spending more time in security queues undergoing more stringent security inspections. TSA security checkpoint procedures have increased passenger processing times and lengthened queues, which has, in turn, reduced demand for pre-security concessions and increased demand for post-security concessions. Stress and anxiety related to security inspection also reduces spending, as illustrated conceptually in Figure 2-10.

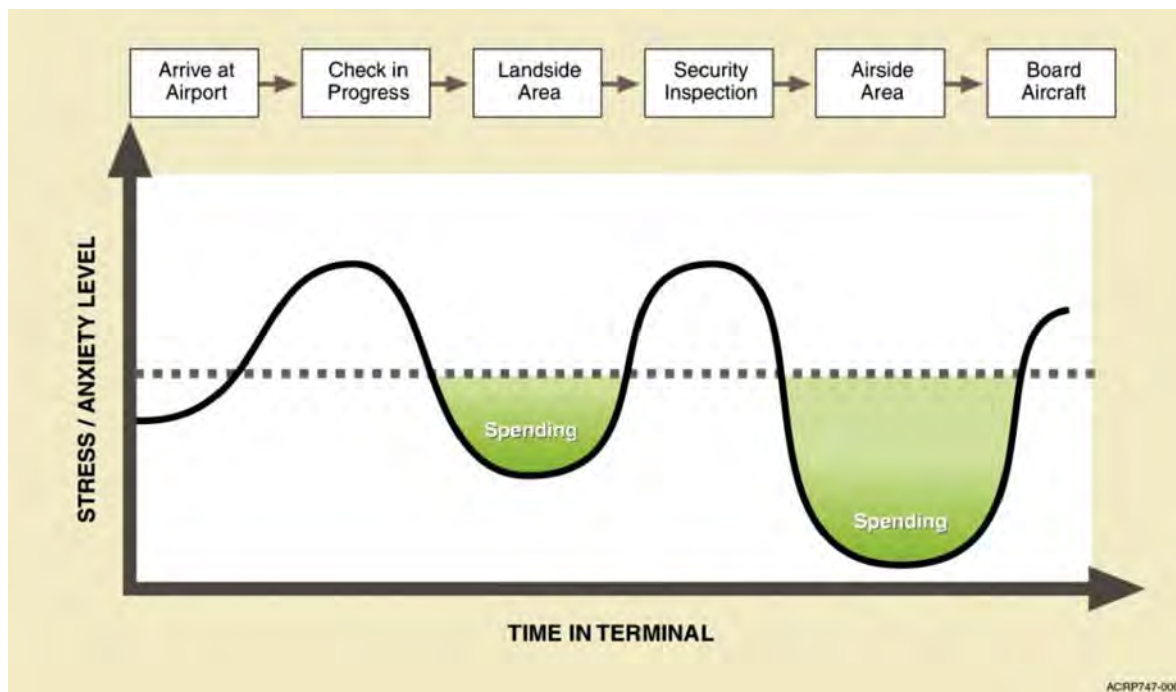

Source: LeighFisher.

**Figure 2-10.** Passenger stress and willingness to spend.



- **Volatility in passenger demand.** Until the attacks of September 11, 2001, there were few examples of “systemic shocks” that could broadly affect airline passenger demand. Previous events, including air traffic controller strikes and airline bankruptcy filings, did not compare to the sudden downturns caused by security concerns following the attacks of September 11, 2001, or the decrease in demand resulting from the “great recession” of 2008–2010. (The 2002–2003 severe acute respiratory syndrome [SARS] epidemic also caused sharp declines in passenger travel, mostly to or within Asia.) The heightened sensitivity to systemic declines in passenger demand has caused concessionaires and airport operators to consider the financial effects of a decline in traffic and the effect of such a decline on the obligation to pay minimum guarantees. While long-term passenger demand is expected to grow, the concern over a sudden traffic decline is being factored into decisions by concessionaires, particularly where the length of term is short and there is less time for a recovery.
- **Changes in the airline industry.** LCCs claimed a 27% share of domestic passenger traffic in 2009 and in 2010 provided more than 29% of available domestic seats. Much of this share is taken from the established network, or legacy, carriers, and the remainder is new traffic stimulated by new service and lower fares. Other changes in the airline industry include the rapid growth in LCC traffic at secondary airports serving major cities, a decrease in the share of connecting traffic flowing through major hubs, and a shift to LCCs in price-sensitive leisure markets. Airline bankruptcies and consolidations through mergers (AirTran Airways and Southwest Airlines, Delta Air Lines and Northwest Airlines, US Airways and America West Airlines, Continental and United Airlines) have resulted in some significant shifts in traffic, particularly at connecting hub airports.
- **Integration of concession areas with holdrooms.** Some new airport terminals are blurring the line between airline-leased holdrooms and concession areas with good effect, making it easier for passengers to use concessions without losing sight of their departure gates. The JetBlue Airways terminal at John F. Kennedy International Airport in New York includes devices for remote ordering of food and beverages along with holdrooms with tables and counters so that passengers can eat close to their departure gates. At San Francisco International Airport (see Figure 2-11), in its redevelopment of Terminal 2, food and beverage concessions are located closer to departure gates, and alternative types of seating (including benches, tables, and chairs) and traditional airport seating are mixed to allow passengers to enjoy their food and beverage purchases closer to their departure gates.



Source: San Francisco Airport Commission 2009, p. 20.

**Figure 2-11. Example of concessions integrated with holdrooms.**



## CHAPTER 3

# Establishing Goals for the Concession Program

In-terminal concessions provide important services to passengers while generating needed revenue for airports. This chapter discusses various elements of an airport concession program and some of the issues involved in developing a concession program, including the following:

- Competing stakeholder demands
- Concession program planning process
- Assessment of customer satisfaction
- Establishment of realistic expectations
- Differences between domestic and international passengers and terminals
- Optimization of sales and revenues
- Preparation of a SWOT analysis
- Common concession program goals

### 3.1 Competing Stakeholder Demands

Because airports are public entities, airport operators face competing demands from stakeholders with an interest in the concession program. These stakeholders typically include the following:



- **Current concessionaires** interested in continuing their tenure under the most advantageous and profitable terms.
- **Prospective concessionaires** seeking a place in the concession program. These could include national companies specializing in airports, regional and local businesses with little or no airport experience, and minority- and women-owned businesses that qualify under the federal Airport Concession Disadvantaged Business Enterprise (ACDBE) Program. An airport held in high regard by the community would be expected to generate strong interest from businesses seeking to associate with a successful, high-profile community asset.
- **Airlines**, which have an interest in the development of nonaeronautical revenue sources, which may reduce the airport's reliance on airline fees and charges. Many airlines prefer that their passengers enjoy the benefit of a well-developed concession program, which strengthens the competitiveness of the airport and, by extension, the airline. Airline managers have noted that airport terminals are an extension of the airline's brand and the customer experience, as identified in their passenger surveys.
- **Concession employees**, who have an interest in employment stability and, in some cases, may advocate policies that support a union-friendly outcome.
- **Airport management**, which has an interest in growing its revenue base and offering a concession program that enhances the reputation of the airport. Management may also have competing interests that require consideration, such as minimizing capital investment or staff costs.

- **Policymakers**, including appointed and elected officials who make the ultimate decisions regarding the concession program. Policymakers may have different views than airport management about the concession program as well as views that airport management sees as unrealistic. Policymakers may also be lobbied heavily by other stakeholders pursuing their own interests.

In recent years, airlines have become supportive of in-terminal concession programs. Airline managers recognize that higher concession revenues help reduce the airport enterprise's reliance on airline landing fees and terminal rentals, thereby diversifying the financial base of the airport enterprise.



Web surveys and interviews conducted for this research found that 67% of airport concession managers believed that the airline influence on concession programs was positive and contributed to a good program, although 79% thought that the overall airline influence was weak. Airport concession managers' views on airline influence, as represented in a survey conducted for this resource manual, are summarized in Figure 3-1.

Concessionaires, however, held a different view, with a plurality holding that airlines did not have a positive influence on the extent and character of concession programs. A similar percentage held a neutral view, and only 14% indicated that airline influence was positive.

Airlines were not always supportive of concession programs, but this has changed in recent years as airlines have given greater attention to the entire passenger experience, including the experience on the ground. As one airline representative noted, airlines may be more supportive of improving concession programs if they are consulted and included in the planning process. Airlines operating major hubs understand that connecting passengers have a choice when it comes to the airport at which they change planes, and the concessions available during their transfer can be a factor in that decision. In markets with competing airports, good concession programs can contribute to creating a positive overall passenger experience and can strengthen an airport's competitiveness. One airline manager interviewed for this study noted that many airlines have come to see the airport terminal experience, including concessions and services, as an extension of the airline brand.

Airlines that operate unit terminals—that is, terminals built, financed, leased, and operated by the airline—have also become participants in planning and managing concession programs. Airlines have developed well-regarded concession programs, including those at JetBlue Airways' Terminal 5 and American Airlines' Terminal 7 at John F. Kennedy International Airport in New York, and Continental Airlines' Terminal 3 at Newark Liberty International Airport.

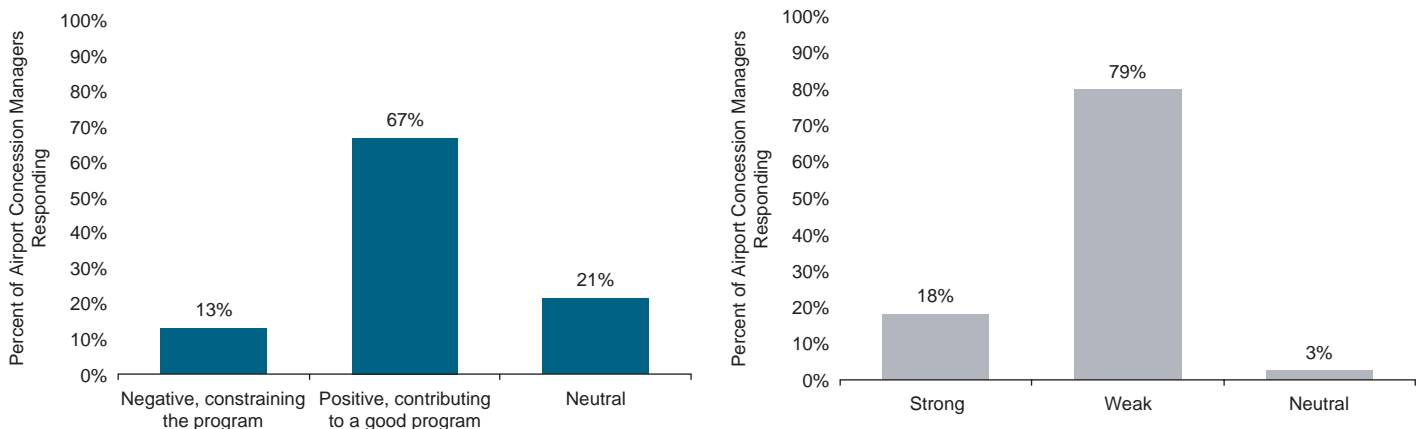

Source: Airport concession manager survey.

**Figure 3-1. Airport concession managers' view of airline influence on airport concession programs.**

Airlines own and operate unit terminals with concession programs in only a few airports, most notably John F. Kennedy International Airport, LaGuardia Airport, and Newark Liberty International Airport, all operated by the Port Authority of New York and New Jersey. At most other airports where the airlines build and operate terminals, the concession programs are administered by the airport operator.

### 3.2 Concession Program Planning Process

Before establishing overall goals for the concession program, it is a good idea for the concession manager to solicit senior management and board-level input on the most important aspects of the concession program and reflect that input in the planning, implementation, and management of the concession program.

Figure 3-2 presents a conceptual diagram of the concession-planning process, highlighting the key steps in establishing concession program goals, the first major task in the planning process.

#### CONCESSION PLANNING PROCESS

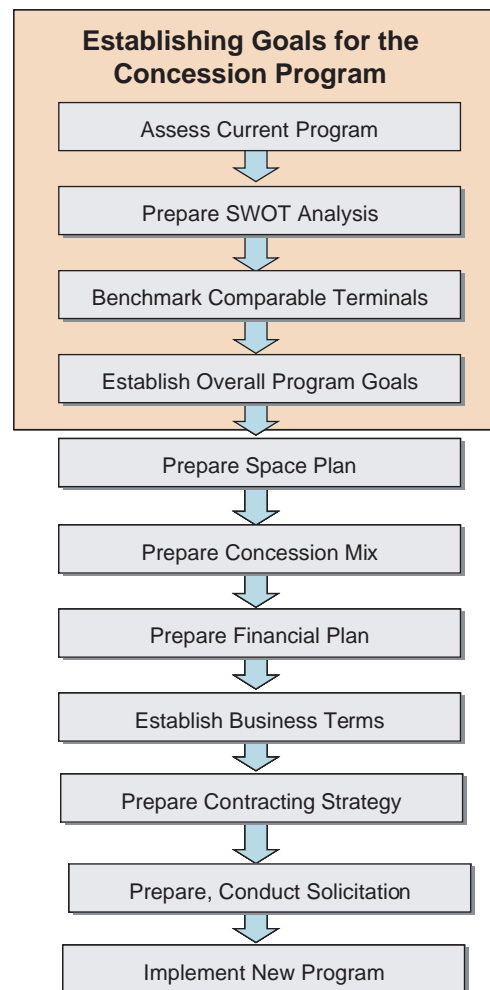

**Figure 3-2. Overall concession planning process and four steps for establishing concession program goals.**

To some, the concept of establishing goals may seem elementary. Some airport managers and concession managers feel they have an intuitive understanding of program goals. However, the value of establishing written goals rests as much in the process itself as in the final outcome. Determining goals can help establish priorities, provide guidance for balancing competing interests, and provide a vehicle for soliciting input from others. Importantly, such goals can be used to create reasonable expectations of what the concession program can (and cannot) be.



Establishing goals consists of four steps:

1. Assess the current program.
2. Prepare a strengths, weaknesses, opportunities, and threats (SWOT) analysis to guide future planning and decision-making.
3. Benchmark comparable terminals that provide a common framework based on what is achievable at an airport with a similar passenger mix, traffic volume, customer demographics, and other attributes.
4. Draft and establish a broad statement of goals based on the above. Once established, the goals will provide a basis for guiding large and small decisions during the planning, solicitation, and implementation phases of a new concession program.

### 3.3 Assessment of Customer Satisfaction

There are few entirely new airports under development around the world, and, in the United States, only a handful of new airport terminals have been developed in recent years. Few concession programs are planned with a completely clean slate, and airport operators will want to evaluate their current concession program's performance before planning a new program or updating an existing one.



Successful concession managers use a variety of techniques to measure customer satisfaction. Ongoing measurement allows for continuous improvement of the concession program. Depending on the measuring technique used, concession managers can identify issues related to customer service, hours of operation, pricing, product mix, and other matters important to passengers as well as areas needing improvement.

#### 3.3.1 Sales Performance Monitoring

At a macro level, careful analysis of sales trends, particularly on a per-enplaned-passenger basis, allows for evaluation of relative performance and can be used to identify favorable or unfavorable trends. A reasonable expectation is for sales performance on a per-enplaned-passenger basis to grow at the rate of inflation. While periods of economic recession may reduce demand in some categories of concessions—particularly specialty retail and duty free—in periods of normal economic growth, it should be expected that sales per enplaned passenger would grow faster than, or at least as fast as, inflation. Between 1998 and 2008, a period that included one recession, but excluded the financial crisis and recession of 2008–2009, the average sale per enplaned passenger for combined food and beverage and retail increased an average of 6.3% per year, or about 3.5% annually when adjusted for inflation.



At a micro level, sales performance of individual concession units can be compared with units in the same category (say, newsstands) or within the same area of the terminal building with similar exposure to passengers.

Outside of the United States, airport operators with highly developed concession programs, including privately owned airports, use detailed sales and revenue per passenger data to track



and evaluate performance against plan. Variances from the plan are a cause for investigation. Privately owned airports are very reliant on terminal concessions and other nonaeronautical revenues for their profits, as aeronautical charges are typically regulated.

### 3.3.2 Passenger Surveys



A standard set of evaluation questions asked on a consistent and periodic basis can, over time, provide a benchmark of customer satisfaction. Positive or negative deviations from an established baseline can indicate favorable or unfavorable trends requiring further analysis and action. Once a baseline is established, ongoing surveys can provide a strong basis for overall program assessment and early identification of trends. BAA, the U.K. airport operator with an excellent reputation for its concession programs, relies heavily on quarterly passenger surveys to monitor performance and identify changing customer preferences.

### 3.3.3 Customer Comment Cards



Long a staple at airports, comment cards in concession units and information kiosks can provide an easy means for collecting customer comments, compliments, or complaints.

### 3.3.4 Complaint Letters



Letters and emails from customers may be indicators of a significant problem requiring investigation, especially if multiple complaints are received from different customers.

### 3.3.5 Social Networking Sites



Social media have skyrocketed in popularity in recent years and are used by many companies and organizations to establish relationships with customers, supporters, and users. The operators of Detroit Metropolitan Wayne County and Tulsa International Airports use social networking sites such as Facebook and Twitter to collect comments, complaints, and suggestions about their airports, including the concession programs. Social networking sites can provide a means for an airport operator to establish a relationship with airport users and learn more about their attitudes and concerns.

### 3.3.6 Mystery Shoppers



Third-party professional shopping services (sometimes called “mystery shoppers” or “secret shoppers”) can provide trained professional shoppers who provide written documentation of all aspects of the customer experience, including, for example, the attitudes of employees, maintenance and cleanliness of facilities, and time waiting for service. Use of a third-party service provides a degree of objectivity that may be helpful if disputes rise to a higher level of management, involve elected officials, or are headed to litigation. An extensive mystery-shopping program is in place at Dallas/Fort Worth International Airport, with units shopped and reported on an average of more than once a month. The Airport board uses this information in evaluating individual tenant performance and in exercising its options to extend a lease term.

### 3.3.7 Focus Groups



Focus groups that include regular airport users under the direction of a skilled facilitator can identify the strengths and weaknesses of a concession program and provide more in-depth and subjective analysis and discussion than can be achieved through surveys and other means.

### 3.3.8 Website Comments

The airport website can also be used to solicit comments from customers and suggestions about future concession improvements, such as new food and beverage concepts or passenger services.



### 3.4 Establishment of Realistic Expectations

Airports have different strengths and weaknesses. It is not reasonable to expect the operator of a small hub airport to create a concession program on par with that of a major international gateway or for an airport with an older, less efficient terminal to be able to provide the concession space needed to take full advantage of the market.

Figure 3-3 summarizes the major factors affecting concession program demand and potential for high performance.

These factors are the following:

- **Terminal configuration.** The layout of the terminals and the number of passenger flows affect the ability to create concessions seen by large numbers of passengers. Older terminals were generally not optimized for concessions.
- **Average trip length.** Passengers making short trips tend to arrive later and spend less time in the terminal. On average, short-haul passengers spend less money than long-haul passengers, who are more likely to make convenience retail purchases and food and beverage purchases for use or consumption during their trip.
- **International versus domestic.** As noted in the preceding section, international passengers generally make longer trips, have favorable demographic and income characteristics, and have a higher propensity to spend. An international passenger connecting to a domestic flight also tends to spend more when using a domestic terminal compared with a passenger making a purely domestic connection. Airports with significant international connecting traffic, such as Miami and San Francisco International Airports, have higher passenger spend rates in their domestic terminals due to their numbers of connecting international passengers.
- **Passenger dwell time.** Longer dwell times in the terminal correlate with stronger concession sales, particularly in food and beverage concepts, such as casual dining restaurants, and in specialty retail shops.

Factor	Less Demand / Sales	More Demand / Sales
1 Terminal configuration	Multiple flows	Single flow
2 Average trip length	Short haul	Long haul
3 International versus domestic	Domestic	International
4 Passenger dwell time	Short	Long
5 Originating versus connecting	Connecting	Originating
6 Purpose of travel	Business	Leisure
7 Passenger demographics	Lower average income	High average income
8 Traffic peaks	A few, concentrated peaks	Traffic evenly distributed
9 Location of concession space	Indirect exposure to passenger flows	Direct exposure to passenger flows
10 Quantity of concession space	Constrained	Commercially optimized



Source: LeighFisher.

Figure 3-3. Factors affecting concession program demand and performance potential.



- **Originating versus connecting.** Connecting passengers have limited time to deplane and transfer to their connecting gates and, therefore, on average have less time to use concessions compared with origin and destination (O&D) passengers. The average spending of connecting passengers is about 70% of that of originating passengers.
- **Purpose of travel.** In most concession categories, leisure travelers have a higher propensity to spend than business travelers, although business travelers are also good convenience retail and food and beverage customers.
- **Passenger demographics.** Not all passengers are alike. Airports serving affluent communities with high disposable incomes have an advantage. Similarly, airports serving major tourist destinations have a higher spending passenger mix and higher spending on gifts and souvenirs than airports mostly serving business travelers or travelers visiting friends and family.
- **Traffic peaks.** Heavy activity peaks can strain the ability of concession units to handle demand, resulting in suboptimal performance. Providing sufficient capacity is particularly challenging at connecting hubs, which may have between four and eight busy periods of intense passenger activity per day, with relatively low activity in between. On the other hand, airports with mostly point-to-point service are less subject to peaks and better able to accommodate demand throughout the day.
- **Location of concession space.** As in all types of real estate, location is critically important. The best concession spaces have exposure to large numbers of passengers. The ideal location will be visible and available to 100% of passengers in a post-security location. Specialty retail shops, in particular, need exposure to large numbers of passengers to be successful.
- **Quantity of concession space.** Providing the optimal amount of concession space is challenging for all but a few airport operators. As terminals age and accommodate higher volumes of passengers, there is heavy competition for the use of space and the ratio of space to numbers of passengers decreases. Providing additional concession space can be expensive and may not be cost-effective in most cases because of the high cost of expanding a terminal.

Evaluation of the factors listed above can be useful in identifying the appropriate benchmark airports and setting reasonable concession program goals. A small hub airport with only domestic traffic and short-haul flights cannot be expected to produce a concession program on par with that at a major international gateway airport. However, the small hub airport can be compared with airports that have similar characteristics and traffic levels to gain insights into what can realistically be achieved. Identifying airports that are “best in class” can be particularly helpful in establishing reasonable goals and the business strategies that can help achieve those goals.

### 3.5 Differences between Domestic and International Passengers and Terminals



International terminals, particularly at some major overseas hub airports, have concession programs that produce the airport industry’s highest sales and revenue and the largest concession space relative to passenger traffic. This section describes the key differences between international and domestic passengers and international and domestic terminals and some of the underlying reasons for the differences.

#### 3.5.1 Differences between Domestic and International Passengers

Compared with domestic passengers, international passengers have a number of desirable characteristics that make them attractive as concession customers. On average, international passengers

- Arrive at the airport earlier and spend more time in the terminal
- Take flights with longer stage lengths (distances), thereby increasing their needs for food, reading material, and other amenities

- Have higher average incomes
- Tend to be more sophisticated travelers and customers than domestic passengers
- Often come from countries with high consumption taxes, such as value-added taxes (VATs), excise taxes on luxury goods, and higher import duties and, therefore, have more incentive to make high-value purchases to realize savings

### 3.5.2 Domestic versus International Terminals

Busy international terminals at U.S. airports typically have higher sales and revenue potential because of the more attractive passenger demographics and purchasing power of the typical international traveler. International terminals do somewhat better than domestic terminals in food and beverage sales because of the longer flights; furthermore, the less-frequent service to long-haul destinations encourages earlier arrival at the airport and longer passenger dwell times. The longer trips also encourage more spending on reading materials, health and beauty items, snacks, travel accessories, and other traditional convenience items.

The greatest difference between international and domestic terminals is the higher spending in duty free shops and, to a lesser extent, specialty retail shops in international terminals. Duty free shops are a major draw in most international terminals and produce the highest sales per enplaned passenger and sales per square foot among all airport concessions. Specialty retail shops also benefit from international passengers and their higher propensity to spend. Longer passenger dwell times and more attractive passenger demographics provide a stronger base for supporting specialty retail sales.

Duty free performance varies more widely than other concession categories because of differences in spend rates that correspond with the nationalities of departing passengers. Airports on the U.S. West Coast serve more of the higher spending Asian visitors. (Spending by nationalities is discussed further in Chapter 4.)

Foreign currency exchange concessions are a lucrative source of revenue in busy international terminals, although they face increased competition from ATMs, which provide funds in local currency from foreign accounts, often at a lower cost to the customer than foreign currency exchange concessions. Nevertheless, foreign currency exchange concessions produce strong revenues and are seldom viable in domestic terminals.

International terminals can support more concession space than domestic terminals. (Establishing space requirements using a supportable space model is discussed in Chapter 5.)

### 3.5.3 Comparison of U.S. and Overseas Concession Programs

There are fundamental differences between U.S. airports and their overseas counterparts. U.S. and non-U.S. concession programs should be compared using caution because of differences in passenger characteristics, local taxation, historical attitudes toward airport concessions, and other factors.

Airports outside the United States often accommodate a higher percentage of international passengers and a lower percentage of domestic passengers compared to airports in the United States, where domestic activity is dominant. For example, of the three airports with the highest concession sales—London Heathrow, Seoul Incheon International, and Dubai International Airports, each with annual sales over \$1 billion—the percentage of departing international passengers is very high—more than 80% at London Heathrow, around 98% at Seoul Incheon, and 100% at Dubai. By contrast, the three busiest U.S. airports have relatively small shares of international passengers—Chicago O’Hare (16%), Hartsfield-Jackson Atlanta (10%), and Los Angeles (28%) international airports. (The largest shares of international passengers among large airports are



enplaned at Miami [49%] and New York Kennedy [47%] International Airports. The largest share of international passengers overall is accommodated at a small hub airport, Orlando Sanford International Airport, used as a gateway by European charter carriers.)

The relatively larger volumes of international passengers provide these airports with greater sales and revenue potential and, therefore, the ability to support larger and more upscale concession programs. However, this traffic is highly concentrated; in 2008, the 10 busiest U.S. airports in terms of total passengers accommodated 70% of U.S. international passengers, and the 20 busiest U.S. airports accommodated 89% of all U.S. international passengers.

### 3.5.4 The European Experience

Airports in Europe were the first to exploit the commercial potential of retail in general and duty free in particular. Shannon Airport in Ireland, once a popular refueling stop for flights between North America and Europe, was the first airport to offer duty free shopping. In time, duty free/tax free shopping became a mainstay of European airport concession programs because of the high percentage of Europeans making intra-Europe flights that involved a border crossing, thereby providing opportunities for passengers to buy heavily taxed luxury goods at low prices.

Because of the greater reliance on the VAT in Europe and the high duties on imported luxury goods, airport shopping represented real value for money compared with prices in local “high street” (main street) shops. The combination of savings, high percentages of international passengers, and high customer spending allowed the creation of small shopping malls in the terminals of European airports. High taxes and duties are major drivers of demand. Figure 3-4 presents a summary of VAT rates for member states of the Organisation for Economic Co-operation and Development (OECD) in 2008. Figure 3-5 presents a summary of taxes on liquor, and Figure 3-6 presents a summary of taxes on cigarettes in OECD countries in 2007 (the latest year for which such data are available). For passengers residing in the United States, duty free shops do not have the same appeal as they do for residents of other countries. In the United States, import duties are relatively low, and local taxes are a fraction of the VAT levied in many industrialized countries. Supermarkets, department stores, and “big box” discount retailers sell at prices that are competitive with U.S. duty free shops.

The large volumes of international passengers and the demand for luxury goods also drive terminal design. International terminals in Europe often feature a single security checkpoint that leads to a major concession area. The single flow of passengers is ideal for creating a large and diverse concession program. Terminals are designed to take full advantage of the spending potential of international passengers.

With the 1999 abolition of duty free sales for passengers traveling between European Union (EU) member countries, a coalition of airports, duty free concessionaires, and product suppliers agreed on a plan to continue the strong value proposition of airports, with each party contributing to keep prices relatively low. Airport operators reduced rent, concessionaires reduced their margins, and suppliers reduced their costs to create what are known as travel value or travel retail shops. Many of these shops offer two-tier pricing, with passengers departing for destinations outside the EU able to buy at lower prices and realize even greater savings. This two-tiered system offers relative value for the intra-EU passenger while offering larger savings for international passengers, replacing much of the revenue that would have been lost after the EU move to abolish intra-EU duty free sales.

The European experience offers a distinct contrast to the evolution of concessions at U.S. airports. Historically, European airports offered genuine savings and an extensive mix of retail shops; U.S. airports evolved from a model characterized by large, often exclusive, contracts



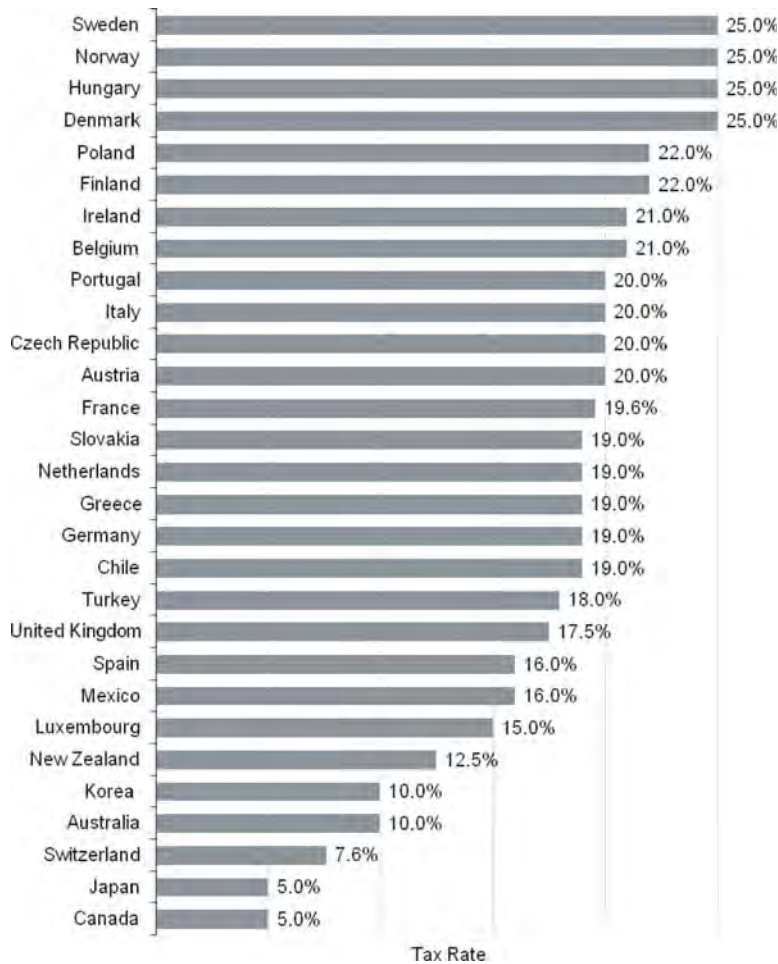

Source: OECD n.d., Table IV.1

**Figure 3-4. Value-added tax rates for select countries (2010).**

awarded to the highest bidder, driving prices higher and limiting selection to high-margin merchandise. The result was high prices and low levels of service, usually in generic and utilitarian concession units. While European passengers have long expected competitive pricing and good value, the same has arrived relatively recently at U.S. airports, where changing customer perceptions on pricing and value have taken considerable time and effort, mostly in the last 20 years.

Local regulations can also make a difference. For example, by law, local shops in Amsterdam must close at 6 p.m. and on Sundays, while the airport is exempt from this requirement. In response, an extensive pre-security concession program serving the substantial numbers of arriving passengers and employees has been developed at Amsterdam Airport Schiphol. Frankfurt Airport has similar advantages, including a license to sell alcoholic beverages after regular local closing hours and on Sundays.

### 3.5.5 Airports in Asia

Asian airports also provide their passengers with good value. In addition to high consumption taxes, excise taxes, and import duties, in many Asian countries, luxury brands are not widely sold and are restricted to sale in a few department stores, limiting price competition. Cosmetics are particularly expensive in Asia, and airport duty free shops offer a strong selection of brands at attractive pricing compared with local department stores.

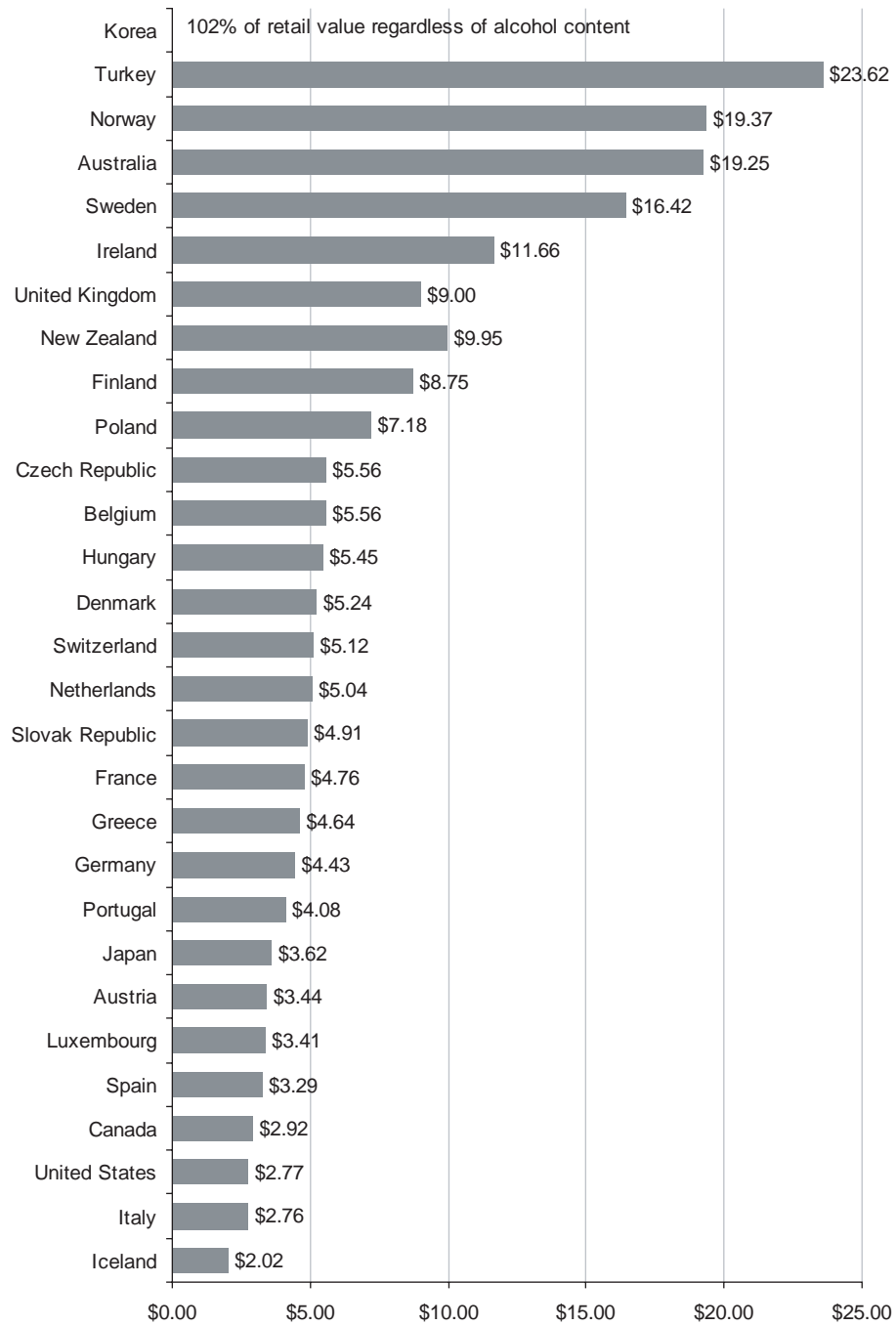

Note: "Whiskey" is assumed to be 40% alcohol by volume and 0.75 liter bottle.

Excludes beer and wine. VAT or sales taxes are additional.

Source: OECD n.d., 2009, Table IV.5.

**Figure 3-5. Comparison of 2007 local excise taxes on liquor (in U.S. dollars).**

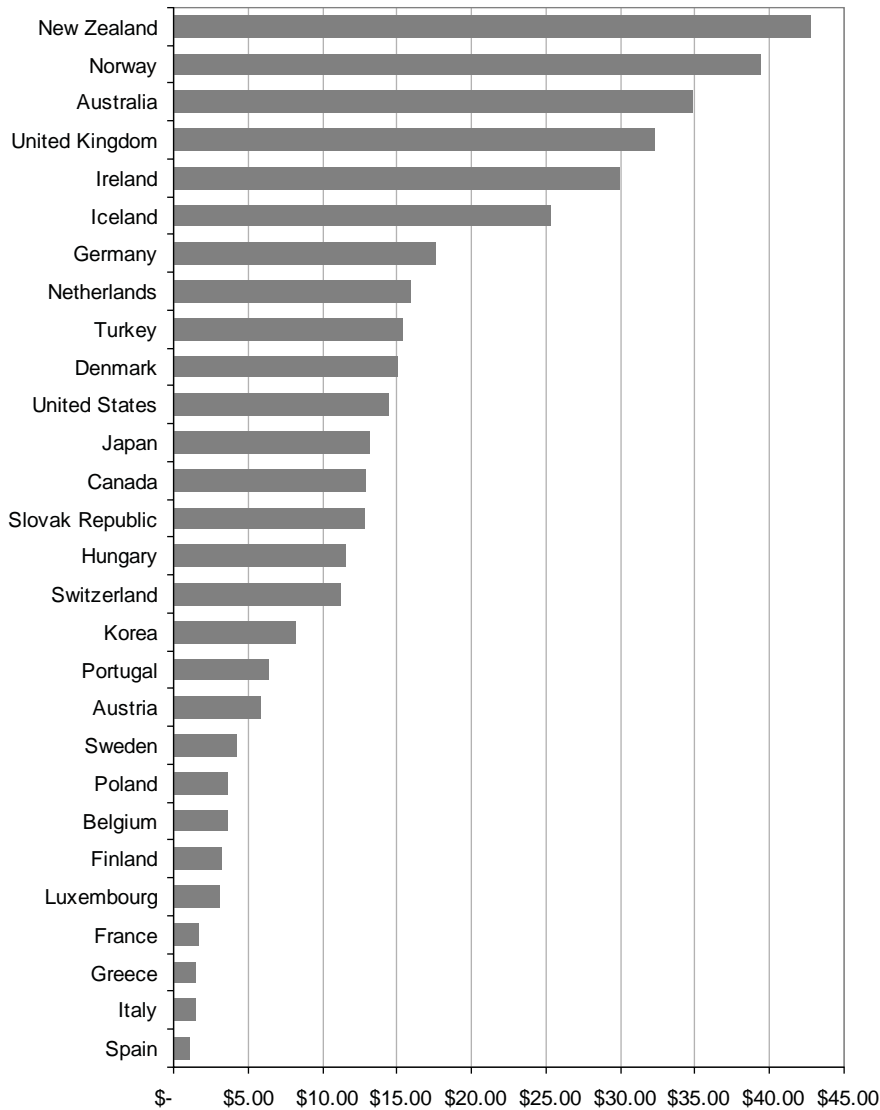

Note: VAT or other sales taxes are additional.  
 Source: OECD n.d.

**Figure 3-6. Comparison of local excise taxes on cigarettes (200 cigarettes) in 2007 (U.S. dollars).**

Asian travelers are also very brand conscious and are more willing to spend large sums on luxury brands and fashion while travelling abroad. In Korea, a bottle of whisky carries an excise tax equivalent to 100% of the price of the product, making duty free shops at airports outside of Asia quite attractive to Asian residents.

For years, the most desirable international passengers were Japanese. According to McKinsey & Company, a consultancy, Japan is the world’s second largest luxury goods market after the United States and accounts for between 10% and 20% of luxury goods sales depending on which categories are included in the definition of luxury goods (Atsmon, Salsberg, and Yamanashi 2009). A combination of domestic taxes and duties, cultural traditions, high brand consciousness, and relative affluence made Japanese passengers the most desirable in the world for concessionaires at airports outside of Japan.

In recent years, Japanese travel and spending have declined following a decade of economic stagnation. According to Generation Research, a duty free consultancy, Japanese duty free sales



have declined over the past decade, as has Japan's tradition of *omiyage*, or gift giving (Generation Research 2010). There has also been a decline in the number of young single women travelers, a fashion-conscious market that boomed prior to the economic downturn.

Meanwhile, numbers of passengers from China are growing at a rapid pace, as are their spend rates. While their purchasing preferences differ from other Asian travelers, Chinese passengers are expected to grow in terms of numbers and relative affluence.

### 3.6 Optimization of Sales and Revenues



Concession sales and revenues can be optimized over the long term by ensuring that the concession program is sufficiently sized to take advantage of the market potential. Many U.S. airports are undersized relative to total passenger demand; lack concession space where it is needed, in post-security departure areas; and have too much space where it is not needed, particularly in pre-security areas and locations that are not along the primary passenger flow.

There are two primary ways to improve revenues and customer service: increase the scale and increase the scope of the concession program. Figure 3-7 illustrates conceptually how sales and revenues can be optimized by increasing the scale (amount of viable concession space) and scope (adding supportable new concepts that increase customer choice and encourage incremental sales) of the concession program.

### 3.7 Preparation of a SWOT Analysis



For concession managers, a good starting point for the concession planning process is to prepare a SWOT analysis for the concession program, juxtaposing the current program's strengths, weaknesses, opportunities, and threats. Strengths and weaknesses refer to internal matters that can be controlled by the airport operator, while opportunities and threats refer to external matters over which the airport operator has little or no control other than to adopt measures to mitigate the potential threats (i.e., risks).

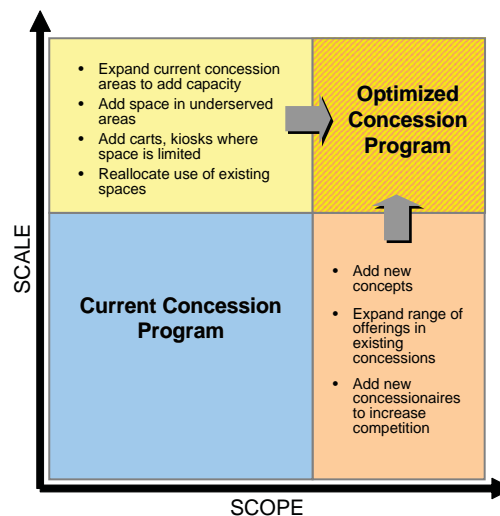

Source: LeighFisher.

**Figure 3-7. Optimizing revenue by increasing the scale and scope of the concession program.**



**Table 3-1. Example of a concession program SWOT analysis.**

	POSITIVE	NEGATIVE
INTERNAL FACTORS	<b>STRENGTHS</b>	<b>WEAKNESSES</b>
	Strong origin-destination market	Lack of post-security space to meet demand
	Consistent long-term growth in traffic	Lack of utilities in some concession units limits cooking and types of food concepts
	Relatively good layout for concessions	Lack of local food and retail concepts
	Local economy growing at a faster rate than national economy	Surplus of pre-security space
	Strong interest in our concession program by potential concessionaires	Some older concessions appear dated
EXTERNAL FACTORS	Planned terminal expansion will provide new concession spaces	Some concepts are weak, tired
		Below average spend rate compared with benchmark airports
		High sales per square foot in post-security areas of terminal indicate a lack of capacity
	<b>OPPORTUNITIES</b>	<b>THREATS</b>
	Additional low-cost airline service could stimulate traffic and concession sales	Terminal expansion may dilute traffic in some areas of the existing terminal, requiring rebalancing
	Expiration of major concession agreements in 2013 allows time to plan a new program	One airline is financially weak and may fail or be acquired, with unknown consequences in terms of future passenger demand
Well known local food concepts could boost spend rates	Lack of consensus on need for concession at Board level	
Low spend rate compared to other benchmark airports shows good upside from an updated program	Current concessionaires may oppose program expansion	
Specific opportunities for more specialty coffee, more specialty retail, and food court expansion		

Source: LeighFisher.

Using the evaluation measures described in Section 3.3 and interviews with concessionaires and peers at other airports, as well as industry consultants, the concession manager can develop a set of attributes that helps define the current program.

This simple technique, used in many aspects of business analysis, can also help provide an easily understood snapshot of the current concession program that can be readily understood by senior management, policymakers, airport staff, and other stakeholders.

Table 3-1 presents an example of a concession program SWOT analysis.

### 3.8 Common Concession Program Goals

For some, a statement of goals for the concession program may seem like a statement of the obvious. However, during concession program planning and implementation, it may become apparent that some concession program goals are in conflict with others. This section presents an overview of some common concession program goals.



### 3.8.1 Good Customer Service

Concession programs should strive to provide good service to customers. There are several factors involved in good customer service:



- Concession staff who are well trained, knowledgeable, friendly, and motivated
- Reasonable pricing, offering value for customers
- Variety in the concession offerings that provide plenty of choices for customers
- Hours of operation that match passenger demand
- Capacity to ensure good levels of service, even during peak periods
- Consistent product quality

### 3.8.2 Branding and Sense of Place

High-performing concession programs create a strong and cohesive identity. To frequent travelers, airports tend to look similar, as do the concessions. The operators of many airports with successful concession programs have differentiated their programs by including local brands, cuisine, shops, merchandise, and services in their programs, offering local passengers both familiar brands and local favorites and nonlocal passengers variety and choice. Local brands can help differentiate the airport and create a sense of place.



### 3.8.3 Concession Theming

Developing a common theme creates a unity of design and brings the attributes of the local community into the airport. Use of local materials, architectural references, history, and culture can contribute to concession theming. Vancouver International Airport is an example of an airport with strong use of theming (see Figure 3-8). Local materials, such as stone and wood, are used in Vancouver International Airport's décor; cultural references, such as native art and totems, are incorporated in its design; and exterior views of nearby mountains are also incorporated. Concessions at the airport reflect this theme through the use of design features and materials that complement the passenger terminal, creating a unity of design.



Source: LeighFisher

**Figure 3-8.** Example of concession theming (Vancouver International Airport).

### 3.8.4 Effective Design and Aesthetics

Strong retail design can motivate customers to visit concessions. For concession managers and concessionaires wishing to create effective designs, a natural tension often exists between the base building architect and the interests of good retail design. In major overseas terminal projects, it is common for a separate retail architect to be engaged to ensure that the concession program is represented in the planning and design process of the terminal.



### 3.8.5 ACDBE Goals

ACDBE participation goals vary from airport to airport and within concession categories because the goals are based, in part, on the availability of ACDBEs and all other businesses in the market that are ready, willing, and able to seek a particular concession opportunity. ACDBE goals largely reflect local values and sensitivities, which are often influenced by minority and women's business groups, local community organizations, trade associations, and the interest in concession opportunities by DBEs. Approaches for achieving ACDBE participation goals through various contractual arrangements are addressed in Chapter 7. Although the emphasis on ACDBE participation will vary depending on local circumstances, such participation is usually reflected in most goal statements.

### 3.8.6 Local Participation

Incorporating local businesses and their concepts and products in an airport's food service and retail offerings can help differentiate the airport, stimulate additional sales, and create a sense of place that is comforting to local users and passengers and interesting to visitors and connecting passengers.



Under the terms of 49 Code of Federal Regulations (CFR) Part 23, *Participation by Disadvantaged Business Enterprises in Airport Concessions*, airport operators cannot grant preferences to local businesses in the award of concessions. However, preferences can be granted for local brands or concepts, as these can be operated by both local and national companies. Major national concessionaires have become skilled in licensing local brands and adapting them for the different airport operating environment. Nevertheless, the use of local operators and concepts requires managing some risks. The local brand may not be as effective as a national brand, and the local operator may have difficulty operating in the complicated airport environment. However, there are numerous examples where local businesses have been successfully incorporated into the airport concession program, such as Dallas/Fort Worth, Denver, Philadelphia, and San Francisco International Airports, among others. The airport operator can help potential operators understand the challenges and risks through local outreach sessions and by educating interested companies.



### 3.8.7 Social Responsibility and Sustainability

Airports are economic engines in the communities they serve. Policymakers are increasingly focused on both economic development and social responsibility, which can be defined as the impact of the airport on society at large. The Airports Council International–North America's Airport Sustainability Committee defines airport sustainability, as follows (2010):

A holistic approach to managing an airport so as to ensure the integrity of the Economic viability, Operational efficiency, Natural resource conservation, and Social responsibility (EONS) of the airport.



Sustainability is one aspect of social responsibility. New terminals are being developed to meet a specific level of Leadership in Energy and Environmental Design (LEED) standards. LEED standards were developed by the U.S. Green Building Council to serve as an internationally recognized green building certification system.

Airport operators have responded to the concerns of policymakers by adopting a range of techniques to create concessions that minimize environmental impacts and increase long-term sustainability. The emphasis on sustainability will vary widely, largely reflecting the standards of the local community. Some major concessionaires have voluntarily adopted sustainability standards for all of their operations and incorporate LEED planning principles in the design and construction of new concession units.

### 3.8.8 Minimizing the Administrative Burden

The administrative costs of managing a concession program vary according to such factors as the overall size of the airport, the number of contracts and concessionaires, the relative sophistication of concession management staff, and other factors. Airport operators seeking to minimize their administrative costs tend to use concession agreements covering a larger percentage of concession space, up to and including multiple prime or master concession agreements. Minimizing administrative costs is unlikely to increase concession revenues over the long term, however, as the relative performance of airports using larger, fewer concession agreements differs from that of airports with more contracts and tenants. (See comparison of concession management approaches presented in Chapter 8.) Minimizing administrative costs may not be cost-effective if the concession program performance is suboptimal.

### 3.8.9 Investment and Revenue Goals



Revenue is not a stand-alone goal. Experience has shown that airports with well-developed and highly regarded concession programs are also among the highest revenue producing airports. Not all airports are created equally and, in establishing revenue goals, the realistic assessment of the revenue potential of the airport must be made, which is best accomplished by benchmarking terminals with similar characteristics. Similarly, full development of the airport concession program's revenue potential may not be possible without capital investment in concession space; modifying existing terminal areas to add concession space; constructing common areas, such as food courts; adding utility capacity; or other investment.

### 3.8.10 Pricing and Value Goals



Airport operators typically adopt pricing policies that influence the nature of the concession program. However, pricing is only one factor in creating value for the customer. Street pricing, while popular with customers, is only achievable if the cost structure for concessionaires, including rent, is viable.

The goals described above are not exhaustive. Local issues may result in the introduction of other goals into the planning process. Figure 3-9 presents a conceptual diagram illustrating how goals are used as input when creating the optimal concession program.

The importance of concession program goals changes with the size of the airport, as shown in Table 3-2. Respondents to surveys conducted for this research ranked customer service as the most important goal regardless of airport size, while goals such as increasing competition and managing the administrative burden were least important. Pricing was more important at medium and small hub airports, perhaps reflecting the smaller number of concessionaires and

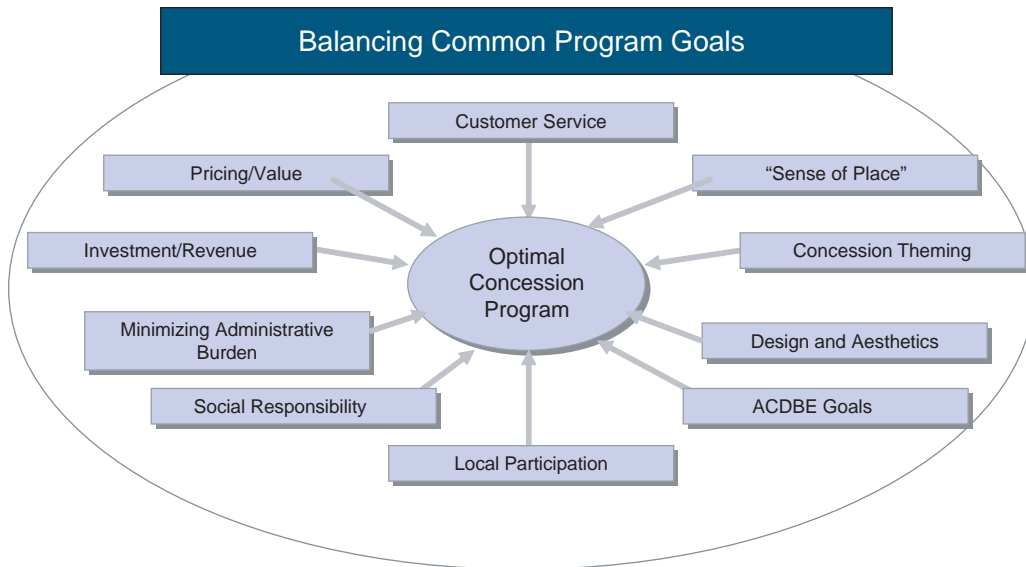

**Figure 3-9. Balancing common concession program goals.**

lack of internal competition typical of such airports. Design and aesthetics were considered of similar importance at all airports.

Overall, the top-ranked goals for all airports were customer service, pricing, and securing the best tenants in each concession category. As an example, goals used during redevelopment of the concession program at Seattle-Tacoma International Airport were the following:

- Represent Seattle and the Northwest
- Provide increase in nonairline revenue
- Provide competitive “street pricing”
- Include both local and national concepts
- Provide great customer service
- Be responsive to market dynamics
- Provide seamless transition management
- Adhere to reasonable Port of Seattle staffing requirements

**Table 3-2. Relative importance of concession goals from survey.**

Goal	Large Hubs	Medium Hubs	Small Hubs
Customer service	1	1	1
Securing the best tenant in each category	2	6	2
Financial (increasing revenue to the airport)	3	2	3
Design/aesthetics	4	4	4
Local brand/"sense of place"	5	5	6
Reasonable pricing	6	3	3
Competition	7	7	8
Managing the administrative burden	8	8	7

Source: LeighFisher using data from the airport surveys conducted for ACRP Project 01-11.



## CHAPTER 4

# The Passenger and Customer Profile

Developing an in-depth understanding of the customer profile specific to the airport is important in planning the future program and maximizing its performance in terms of customer service, customer satisfaction, sales, and airport revenue. This chapter addresses the several elements to be considered in defining an airport's customer profile including the following:

- The airport and its customers
- Passenger segments
- Other customer segments
- Demographics and market segmentation
- Identifying gaps—why certain market segments do not patronize concessions
- Customer surveys and focus groups

### 4.1 The Airport and Its Customers

Often, international and domestic passengers are processed in separate and distinct concourses, and the numbers of passengers in each of these segments may be quite different. Concourses may accommodate different airlines serving different destinations, with one enplaning a significant number of business travelers and another enplaning a high percentage of leisure travelers. The concession program will require some adjustments to best serve each of these segments.

Other variables, such as demographics, nationality, destination of passengers, reason for travel, and whether they are O&D or connecting passengers, will affect passenger behavior, their purchasing habits, and their wants and needs at the airport.

Market researchers use a more sophisticated market segmentation methodology in advertising and marketing research than is usually used in planning an airport's retail concessions. Market segmentation involves breaking down the universe of potential customers into distinct groups. As an example, one international food and beverage concessionaire has developed a Consumer Profile Matrix based on seven consumer mindsets, ranging from low interest in food to a highly discerning approach, and on six basic need states, ranging from time-driven to environment-driven. At the airport level, a market segmentation approach is used at Dallas/Fort Worth International Airport. This approach, described in more detail later in this chapter and in a case study included in Chapter 14 of this resource manual, allows the airport board to segment its passengers by demographics, "life stage," urban density, and other factors to determine propensity to purchase, brand preferences, and other factors used in concession planning.

Other nonpassenger segments may also generate a significant portion of the concession sales. The specifics of these additional market segments are also discussed in this chapter.



The success of any concession program partially results from developing a thorough knowledge of the airport's market segments and adapting the concession mix to the needs, wants, and preferences of these segments. These market segments must first be identified and defined and may vary significantly from one airport to another and from one terminal or concourse to another in the same airport. For example, Terminal 4 at New York's Kennedy International Airport has a very different customer profile compared to the customer profiles at other terminals at the airport because of the large and diverse number of airlines operating from that terminal.

Furthermore, the wants and needs of the customers should be defined in terms of their preferences for concession types and categories, products, services, and brands. The definition of these preferences is most often determined using market research tools, such as direct customer surveys. Only after these preferences are defined will it be possible for the airport operator to fine-tune its concession program to respond accordingly, optimizing the locations of concessions and maximizing the level of service, gross sales, airport revenue, spend per passenger, and space productivity.

## **4.2 Passenger Segments**

Passengers using an airport may be divided into several subgroups that behave quite differently while circulating throughout the terminal building. This behavior affects their propensity to patronize the concession program and influences the locations of the concessions, as well as the products and services offered. Several variables may be used in segmenting an airport's customer base. The most common passenger segments are described in this section.

### **4.2.1 International Departing Passengers**

The proportion of international passengers flying out of an airport will affect the size and location(s) of the duty free outlets, the types of specialty shops, and the types of food offered. Market research has demonstrated that international departing passengers have a far greater propensity to spend at airport concessions than other passenger segments. In addition, these passengers are the only ones eligible to purchase goods on a duty and tax free basis at duty free shops, although some duty free operators are now offering a limited selection of tax-paid merchandise to all passengers.

Because of their specific check-in and boarding processes, airlines may often require that international passengers arrive at the airport more than 2 hours in advance of their scheduled departure time. This longer dwell time is conducive to shopping and eating. Airport operators should try to capitalize on this longer dwell time as much as possible. Conversely, airlines may place limits on how early a passenger can check baggage for a flight, creating demand for landside concessions (pre-security).

### **4.2.2 International Arriving Passengers**

The international arriving passengers have special needs, such as currency exchange services and baggage carts within the post-security international arrivals zones. International passengers expect these needs to be accommodated, as they are considered customary at international airports.

Although arriving passengers typically show minimal interest in food, beverage, and retail concessions compared to departing passengers, careful consideration should be given to conveniently locating some service concessions of interest to these passengers. International terminals have certain advantages compared with domestic terminals. First, these arriving passengers are deplaning from long international trips and have just experienced the stress of Immigration and



Customs inspection. Second, international passengers reaching their destination are more likely to be met by friends or relatives. Finally, arriving international passengers are more likely to be funneled through a single exit from the secure Customs area, allowing for concessions geared to arriving passengers and their meeters and greeters to be clustered, preferably in visible locations.

### **4.2.3 Domestic Departing Passengers**

Departing domestic passengers account for the largest percentage of concession sales at many airports. The types and numbers of these passengers should be carefully considered in determining the concession mix and the location of the concessions and in evaluating the overall performance of the terminal concession program. These passengers are often encouraged to arrive at the airport at least 2 hours before their flights are scheduled to depart, which, in many cases, allows ample time for clearing security and making purchases at the post-security concessions. In addition, because of the reduction in the offer of onboard food, domestic departing passengers have become major consumers of grab-and-go food that they can take with them on their flight.

### **4.2.4 Domestic Arriving Passengers**

Although arriving domestic passengers are most often anxious to leave the airport to reach their ultimate destinations, they may constitute a good market for the purchase of convenience items to take home or to their place of accommodation. A limited amount of concessions offering concession services to domestic arriving passengers may be viable, but the revenue potential is likely to be limited. Arrivals area concessions are often not financially viable on a standalone basis, but may be marginally profitable when packaged with other concession units serving departing passengers.

### **4.2.5 Connecting Passengers**

The circulation pattern of connecting passengers within the terminal building is significantly different from that of O&D passengers. Furthermore, layover times can be short for connecting passengers, so concessions on these passengers' circulation path or near the departure gates are best located to take advantage of this segment's buying potential. Some connecting passengers may remain airside while others may need to exit the security area to access another secured terminal area. The specific circulation pattern at the airport and the route and volume of passengers should be assessed to ensure that the right assortment of concessions in the right locations is offered to this passenger segment. The importance of this segment can vary considerably from one airport to another, depending on the number of connecting passengers and their behavior patterns.

## **4.3 Other Customer Segments**

Concession customer segments may be determined using other segmentation variables, such as demographics, nationality, destination, or trip purpose (business or leisure). These variables greatly influence passenger behavior and the propensity to shop and make purchases at airport concessions. The value of the transaction is also influenced by these variables, as well as by variables such as the income of the passenger.

An airport's customer base also includes nonpassenger segments, such as meeters and greeters waiting for arriving passengers, well-wishers accompanying departing passengers, and employees who can generate a significant portion of a concession program's sales. These segments are described in more detail in the following sections.

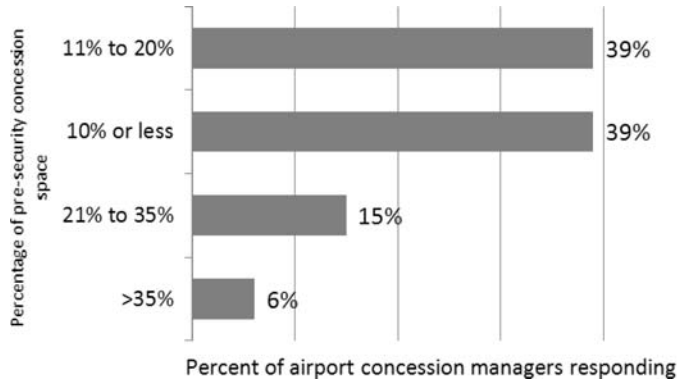

Note: 16 large and 16 medium hub concession managers responding.  
 Source: LeighFisher using data from the airport surveys conducted for ACRP Project 01-11.

**Figure 4-1. Concession managers' preferences regarding the location of concessions before and after security inspection.**

### 4.3.1 Connecting versus Origin and Destination Passengers

The volume of connecting passengers within a specific airport's customer base influences the locations and sizes of concessions and the types of concessions in the concession mix.

The propensity of passengers to spend pre- or post-security varies greatly depending on the composition of the passenger market. As part of the research conducted for this study, airport concession managers were asked what they thought would be the preferred split of concession space pre- and post-security. Figure 4-1 shows the combined responses to this question of 32 large and medium hub airport concession managers. The percentage of respondents indicating that 10% or less of space should be located pre-security and the percentage of respondents indicating that 11% to 20% of space should be located pre-security were the same.

Figure 4-2 illustrates the average time spent by passengers before and after security at a U.S. West Coast airport. The time varies from one terminal building to the other. Again, only a thorough knowledge of passenger behavior will allow the airport operator to determine the optimal split.

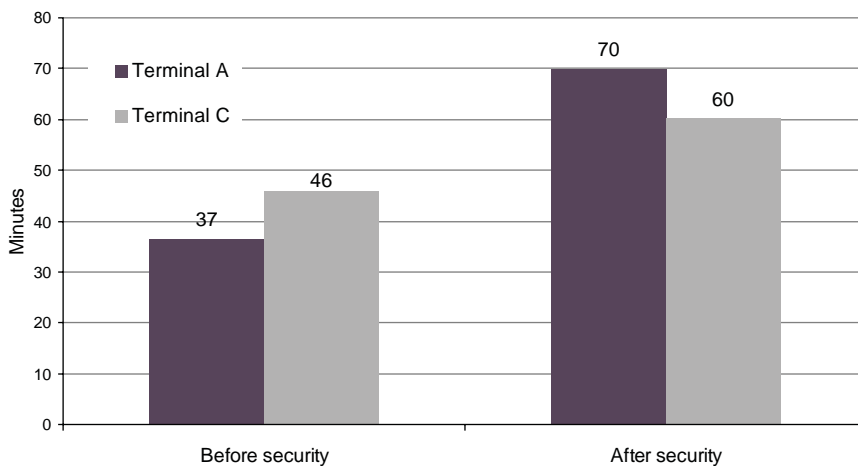

Source: Survey conducted by LeighFisher in 2004.

**Figure 4-2. Average time passengers spend before and after security by terminal at a U.S. west coast airport.**

### 4.3.2 Business versus Leisure Travelers

Passenger surveys and studies have demonstrated that business and leisure travelers exhibit different behavior and spending patterns. The typical leisure traveler, who is using discretionary income to travel, is naturally more sensitive to pricing than the business traveler on a corporate expense account. The proportions of business and leisure travelers affect the mix of products, services, and concessions in a concession program, as well as the pricing strategy.

Business travelers tend to arrive at the airport much closer to their departure times and thus have shorter dwell times in the terminal building. Concessions must be located directly on their circulation path, as these travelers do not have much discretionary time or inclination to wander and browse in a terminal to find what they might like to purchase.

On the other hand, leisure travelers, especially those who do not fly frequently, are more likely to arrive at the airport earlier than business travelers and, thus, have longer dwell times in the terminal to browse and shop. Additionally, leisure travelers are more likely to be accompanied by family members or other traveling companions, which will also influence the products/services included in the concession mix.

### 4.3.3 Meeters and Greeters

Surveys have shown that the ratio of meeters and greeters to passengers varies significantly with the demographics of the passengers served at an airport. This ratio is much higher for some nationalities than others. Meeters and greeters tend to remain in the arrivals area and are not likely to wander far from the location where they can meet arriving passengers.

The optimum concession locations to serve this market vary depending on the terminal. In some cases, meeters and greeters congregate on the departures level near the exit from security or in conveniently located “meeting places” established by the airport operator. In other terminals, arriving passengers exit the secure zone in the baggage claim area.

Where passenger flow is dispersed among many exits from the secure area, the opportunity to create a critical mass of concessions in one location and a profitable concession program is reduced. Ideally, meeters and greeters would wait on the same level as baggage claim, creating a larger market for concessions in the arrivals area.

### 4.3.4 Well-Wishers

Similar to meeters and greeters, well-wishers, or people accompanying departing passengers, are not allowed in the post-security areas. Pre-security concessions offer an opportunity to serve this segment before the accompanying passengers enplane. For example, people accompanying departing passengers may wish to have a meal or a beverage with the passenger(s) they accompany before they proceed through security. The optimal amount and the proportion of pre-security concessions are influenced by the specific ratio of people accompanying departing passengers to departing passengers at an airport.

Cultural differences can affect demand in this market segment; people accompanying departing passengers from some cultures are more likely to spend time with passengers at the airport before they leave on a trip.

### 4.3.5 Employees

Employees represent an important market segment of potentially repeat customers and may generate a significant portion of concession gross sales, especially in the food and beverage and

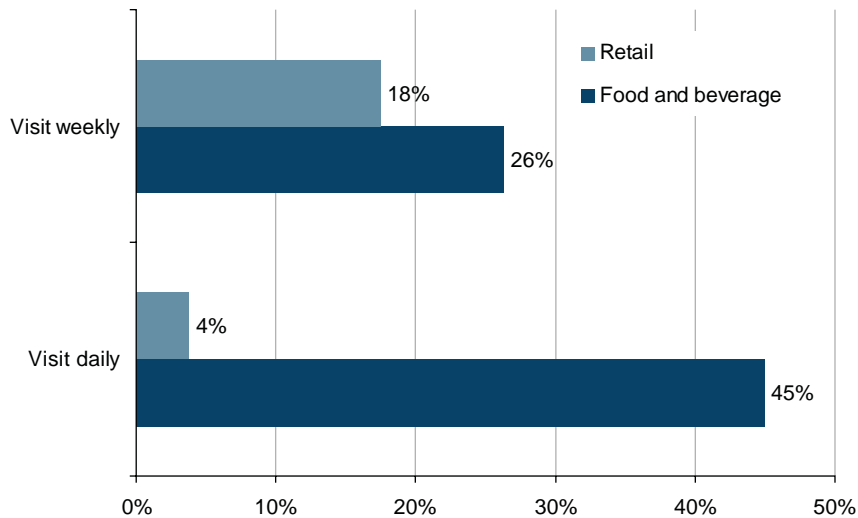

Source: Survey conducted by LeighFisher in 2004.

**Figure 4-3. Percentage of airport employees visiting concessions at a U.S. west coast international airport.**

convenience retail categories. This segment is often overlooked, but surveys have indicated that employees can account for as much as 40% of some quick-serve sales, particularly for fast food concepts with low price points. To illustrate this fact, Figure 4-3 shows the proportion of employees visiting retail and food/beverage concessions on a daily and weekly basis at a U.S. West Coast international airport as determined through a survey.

Figure 4-4 illustrates the average weekly expenditure of airport employees in retail and food and beverage concessions at the same airport.

While some employees may only have pre-security access, some have a security clearance and may be potential customers for post-security concessions. It is therefore important that the airport operator consider the proportion of employees with post-security access when determining the concession mix and price points.

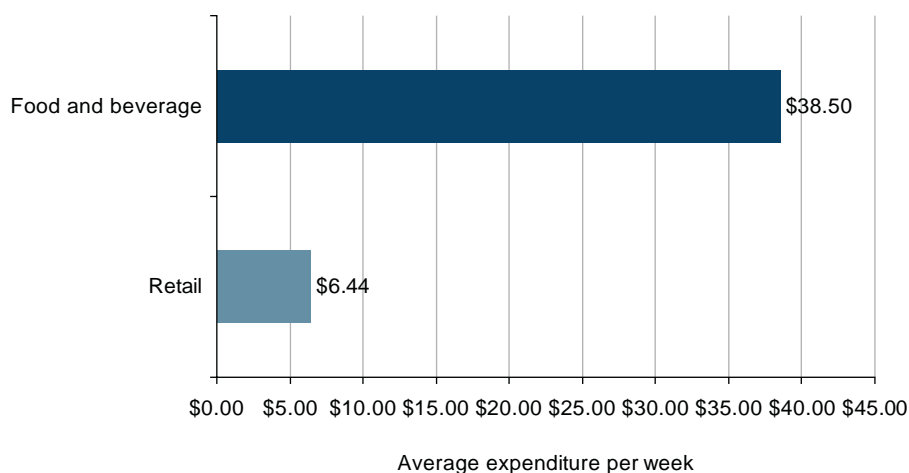

Source: Survey conducted by LeighFisher in 2004.

**Figure 4-4. Average employee expenditures per week at airport concessions.**



## 4.4 Demographics and Market Segmentation

The demographics of passengers and other customer market segments have a strong influence on customer needs and wants and on the concession mix and the products/services offered at the concession units in each commercial zone of a terminal building. A good example is the major international fast food chain, McDonald's, which adapts its products to satisfy the needs and wants of its specific markets around the world. In Belgium and Germany, McDonald's serves beer, while at its units in India, beef is not on the menu. In Costa Rica, rice and beans are available in addition to fries, as are shrimp burgers in Japan. Customizing the offer to meet local needs makes sense for concessionaires, as well as for airport operators.

Demographics also have a major influence on the discretionary revenue of individual passengers and their propensity to shop, which, in turn, influences the targeting of the concession. For example, should the concessionaire be selling high-end, medium-end, or lower-end watches? Or should it be selling different watches in different terminals, with high-end watches in the international terminal and lower-priced watches in terminals used by leisure travelers?

The destination of outbound passengers, especially international passengers, can also significantly influence shopping behavior and spending patterns and, in turn, significantly affect the performance of a concession program as well as its composition. Figure 4-5 illustrates the results of a recent survey of a major Eastern U.S. international airport terminal. At that specific airport, passengers traveling to Britain/Ireland had an average spend rate significantly higher than other groups, followed closely by passengers headed to Asia and Eastern Europe. This information differs from the information collected by nationality, as it relates to preferences for all passengers traveling to a specific destination regardless of nationality.

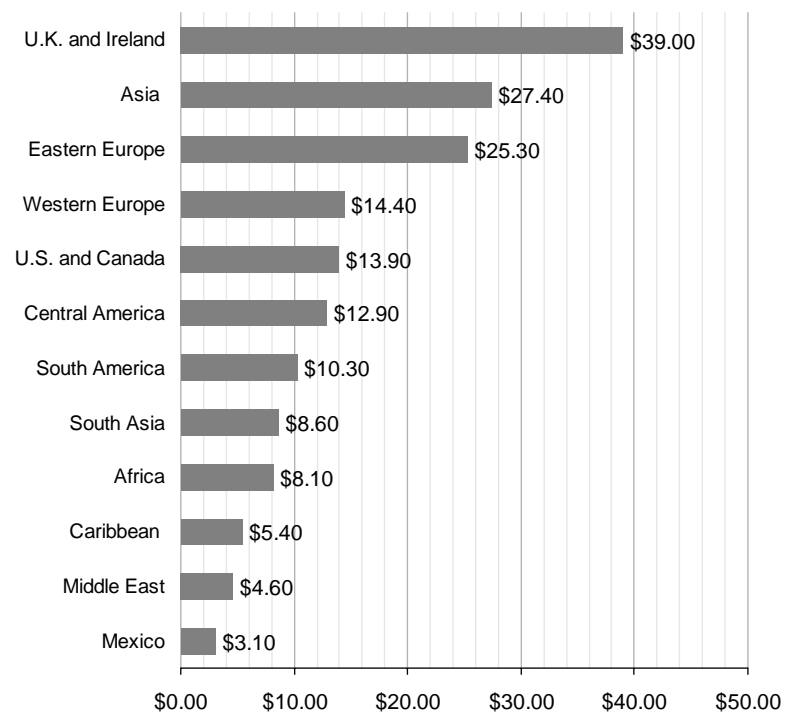

Source: LeighFisher, from survey conducted at a major eastern U.S. airport's international terminal in 2007.

**Figure 4-5. Average total spend rate per enplaned passenger by destination.**

Information relevant to successful airport concession planning can be gathered through or extracted from customer surveys. Information typically collected through such surveys includes the following:

- Household income
- Age
- Nationality (discussed below)
- Travel characteristics of the airport’s passengers (e.g., O&D or connecting, trip destination, number of flights per year, number of non-travelers accompanying them, average time at airport, average time spent before and after security, business vs. leisure travel)
- Average spend by
  - Nationality
  - Destination
  - Airline
  - O&D/connecting
  - Business vs. leisure
  - Age
  - Household income

In addition to demographic data, surveys may also collect customer preferences that can be associated with the demographic data, including preferences for restaurants and shops not currently at the airport and passengers’ assessments of how well the current program meets their needs, including strengths and weaknesses. The global performance of a concession program is linked to all of these factors, as they provide valuable information regarding an airport’s concession program. The more a concession program is adapted to these characteristics, the better its performance will be.

The differences in spending by international destinations are significant. The same principle can be applied to domestic passengers through survey research, with spending patterns identified for an airport’s major markets. The differences may not be as great, but the information can be helpful in tailoring an airport’s concession program.

#### **4.5 Identifying Gaps—Why Certain Market Segments Do Not Patronize Concessions**

Even well-planned concession programs are not patronized by a percentage of passengers. Figure 4-6 presents some of the reasons given in a passenger survey for not buying. Figure 4-6 indicates that some consumers still think that prices at airport concessions are higher than street prices.

#### **4.6 Customer Surveys and Focus Groups**

The importance of gaining an in-depth knowledge of the various segments of an airport’s customer base—in terms of demographics, wants, needs, and preferences—to be able to develop a concession program that will perform well was discussed in previous sections. An airport operator can gain this knowledge in several ways. The methods used most frequently are customer surveys and focus groups. A wide variety of survey methodologies are available to airport operators. For more details on these methodologies, please refer to *ACRP Report 26: Guidebook for Conducting Airport User Surveys* (Biggs et al. 2009).



The surveys and interviews conducted as part of this research project indicate that approximately 80% of airport operators conduct some type of customer/passenger survey. However, a



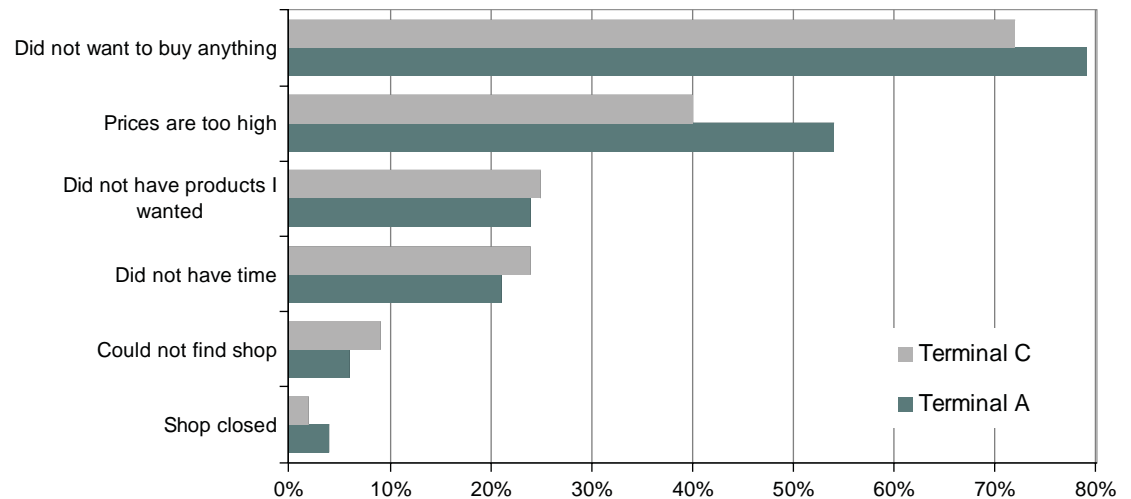

Source: Survey conducted by LeighFisher In 2004.

**Figure 4-6. Reasons given for not patronizing airport concessions (U.S. west coast airport).**

much smaller share of airport operators conduct customized surveys of various customer segments specifically designed to acquire better knowledge of the customer base, demographics, wants, needs, and preferences to help adapt concession programs to accommodate these parameters.

As discussed earlier, employees can generate a significant amount of concession program gross sales, especially food and beverage. The survey conducted for this study indicated that only about one-third of airport operators reported surveying employees, and just under half of airport operators reported surveying meeters/greeters and farewellers. Although these segments are small in relation to the departing passenger segment, identifying the needs and wants of these market segments can strengthen the overall concession program and provide long-term incremental revenues for the airport enterprise.

#### 4.6.1 Passenger Surveys

Several factors should be considered when selecting a passenger survey methodology, including speed, complexity of the inquiry, flow control, visual aids, and confidentiality.

The most common type of airport user survey, the passenger intercept survey, focuses on passenger characteristics, preferences, and satisfaction with the airport. Usually completed by trained survey staff at holdrooms, the intercept survey can obtain valuable information from passengers who have formed impressions after their use of concessions and just prior to their leaving the airport.

About one-third of airport concession managers indicated that surveys were conducted at their airports more than once per year, while only 18% of airport operators conducted surveys annually. About one-quarter of airport operators indicated that they conduct surveys only at the time of new program development or never. These results are presented graphically in Figure 4-7. Figure 4-8 illustrates the percentages of airport operators using various sample sizes in their passenger surveys. Sample sizes will vary according to survey objectives, number of terminals, and other factors. *ACRP Report 26: Guidebook for Conducting Airport User Surveys* is a comprehensive resource on airport survey research.



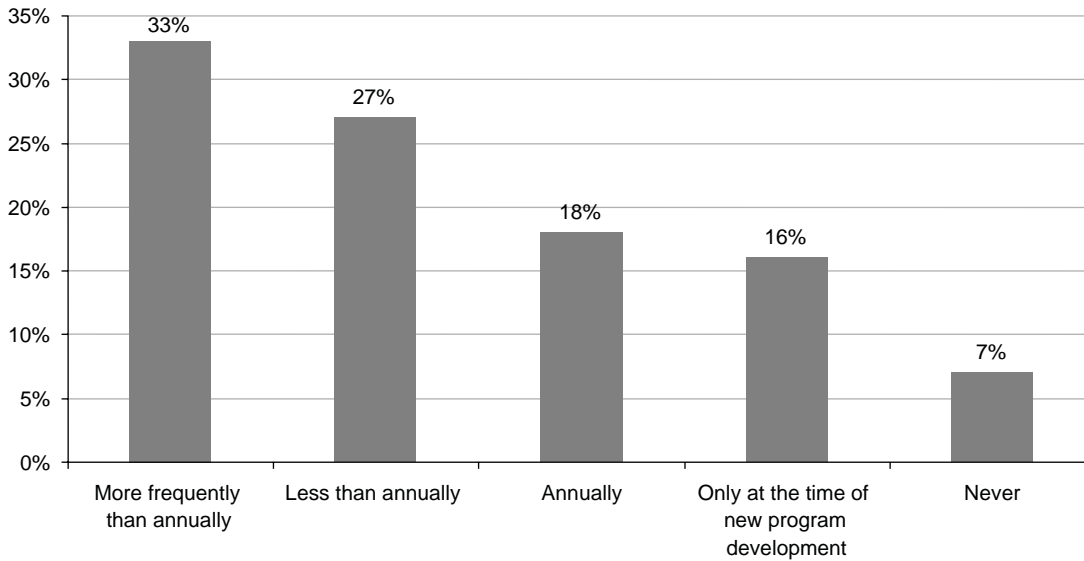

Source: LeighFisher using data from the airport surveys conducted for ACRP Project 01-11.

**Figure 4-7. Frequency of passenger surveys conducted by airport operators.**

### 4.6.2 Meeter/Greeter and Well-Wishers Surveys

Surveys of meeters and greeters should focus on the characteristics of those meeting passengers, the number of persons in the party, the distance traveled to the airport, the typical amount of time spent at the airport, and customer buying or preferences for types of concessions. Numbers of meeters and greeters are often estimated for airport or terminal master plans using broad-based estimates based on other airports or using a rule-of-thumb ratio of meeters/greeters to passengers. These kinds of estimating methods can easily overestimate or underestimate the numbers of persons meeting/greeting passengers. Verifying the strength of the potential market through a survey can help the airport operator (and its concessionaires) avoid making costly mistakes.



In some parts of a country, cultural differences result in stronger demand. For example, persons of Hispanic origin in Miami tend to arrive at the airport in large groups to meet arriving passengers, as do persons of Italian descent in Montreal. In Los Angeles and San Francisco, Asian

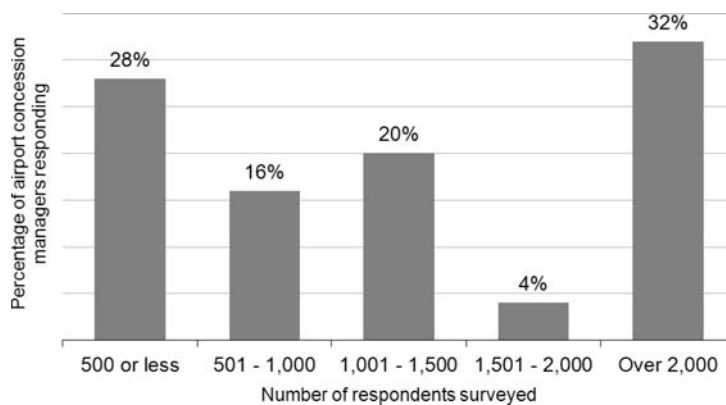

Source: LeighFisher using data from the airport surveys conducted for ACRP Project 01-11.

**Figure 4-8. Sample sizes used by airport operators in passenger surveys.**

residents travel to the airport to spend time and enjoy a meal with the traveler before departure. This cultural trait can be best observed at airports in Asia, such as Singapore Changi and Seoul Incheon International Airports, where there are multiple restaurants, both casual and formal, in addition to quick-serve food courts in pre-security departure areas. Narita International Airport's Terminal 2 has 15 pre-security food and beverage units, including Japanese, Chinese, and western restaurants.

Understanding the available opportunities can help airport and concession managers make sound long-term concession planning decisions. Survey questions for meeters/greeters and well-wishers typically cover the following:

- Number of persons in party
- Age group
- Gender
- Frequency of visits to airport
- Opinion on concessions and services in terminal
- Preferences for concessions and services
- Time spent in airport
- Amount spent in airport
- Distance traveled to airport
- Household income

#### 4.6.3 Airport Employee Surveys

Employee surveys are usually conducted to measure satisfaction with airport facilities and services, obtain information for transportation or concession planning, and address issues such as communications and knowledge of airport procedures. The survey questions typically cover the following topics:

- Category of employer (airline, airport, tenant, or other)
- Full-time or part-time employee
- Frequency of concession visits and average spend per concession category
- Opinion on location of concessions within terminal
- Preferences in terms of brands, products, etc.
- Age group
- Household income
- Gender

#### 4.6.4 Other Surveys

Several other survey methods are available to airport operators, such as the following:

- **Self-completed surveys**, which are handed out to passengers at or near their holdrooms, completed by the respondent, and then returned either in person or by mail. If the surveyor remains near the passengers while they complete the survey, he or she can act as a resource if some respondents have questions about some of the questions.
- **Mail surveys**, which are infrequently used at airports, mostly because of the wide distribution of airport customers around the world. This type of survey often yields a low response rate.
- **Telephone surveys**, which are useful for surveying households and businesses in the area served by the airport, but not practical for surveying passengers. Face-to-face interviews at the airport are much more efficient than randomly telephoning the population of an airport's catchment area.
- **Internet surveys**, which are extremely inexpensive and have become increasingly popular in recent years. Although convenient in certain situations, these surveys have been criticized,

mostly because the sample of respondents could be biased. For example, people who are dissatisfied with one or more aspects of airport service and wish to complain about it have a greater likelihood of responding to an Internet-based survey than fully satisfied customers.

#### **4.6.5 Focus Groups**

Focus groups are used when the detailed opinions of members of a specific group are desired. Focus groups provide an opportunity for the airport operator or concession manager to discuss certain issues in more depth than could be achieved using a standard customer survey, with representatives of certain market segments, and to obtain qualitative data about the airport concession program. The selection of individuals forming the focus group is of paramount importance, as these individuals greatly affect the results. A trained facilitator should be used to lead the discussions and elicit in-depth opinions and their underlying rationale.

#### **4.6.6 Concessionaire Interviews**

One often overlooked source of information that can be helpful in understanding an airport's customers is the existing airport concessionaires. Concessionaires, particularly local managers, are on the front lines of customer service and can provide a wealth of knowledge about current customer behavior, gaps in the current concession program, and preferences of particular market segments. Regional managers and business development representatives of major concession companies can also help airport operators in understanding broader industry trends and how they may apply at specific airports. Concession consultants routinely interview current concessionaires when preparing concession plans for clients. While concessionaire representatives may be advocates of a particular view or policy that benefits their company, they can be a good source of front line information. Regular meetings with concessionaires are recommended as a means to develop an understanding of the market from those who serve it.

#### **4.6.7 Advanced Market Research Techniques**

Consumer product companies use market research to understand their customers' demographic status and lifestyle preferences. Consumer research firms conduct broad-based research of buying trends, income, lifestyles, family status, and residence using census and zip code data typically used in market research, advertising, retail location decisions, and other commercial applications.

This extensive demographic research has been applied at Dallas/Fort Worth International Airport using the Nielsen company's Claritas market demographic identification and segmentation system. Capturing the zip codes of the airport's originating and connecting passengers allows segmentation of passenger profiles into 63 distinct lifestyle groups that identify shopping and media preferences as well as key demographic and socioeconomic characteristics. Lifestyle groups are also characterized by urban density into four groups—urban, suburban, town and rural, and second city—and further classified according to socioeconomic rank and “life stage” group, based on the presence and age of children.

This market research enables airport concessions staff to develop an in-depth understanding of their customers and their preferences for brands, products, and services. This information is also provided to current and prospective concessionaires, to enable them to better understand their customers. Furthermore, there is wide variation in the characteristics of the market in each of the airport's five terminals, allowing for further segmentation and tailoring of the concession offerings.

The application of these advanced market research techniques is discussed further in the case study of Dallas/Fort Worth International Airport included in Chapter 14.



## CHAPTER 5

# Developing the Concession Space Plan

This chapter outlines the steps required to prepare the spatial elements of the concession plan, considering the passenger profiles discussed in the previous chapter, and covers the following topics:

- Space planning
- Supportable concession units based on traffic levels
- Sizing of concession units
- Location criteria
- Adjacencies
- International terminals
- Wayfinding and concession signage
- Return on airport investments in concession space

### 5.1 Space Planning

Concession space planning is a critical task in terminal program development. As airport operators have realized that excellent concession programs not only increase revenues, but are also closely related to passenger satisfaction with the overall airport experience, concession space planning has become an integral part of the terminal design process.

In developing concession space plans and concession locations, the airport operator's goals are typically the following:

- Optimize concession revenues
- Increase customer penetration rates (the percentage of passengers and visitors using a concession) and average transaction levels (the average amount spent per transaction)
- Provide a wide variety of concessions with a broad selection of services and product choices
- Create interesting and entertaining concession choices for the customer
- Integrate food and beverage with retail to create synergy and encourage spending across categories
- Allocate as much concession space as can be financially supported during the design life of the terminal
- Promote open-sell rather than over-the-counter sales to promote spontaneous purchases
- Establish a strong commercial image and identity

As the airport concession industry has matured, a structured approach to planning has evolved. Although industry consultants recommend a structured approach, 67% of airport operators surveyed indicated that they use a concession space planning metric or standard. About 60% indicated that they had adopted planning standards for concession support space.



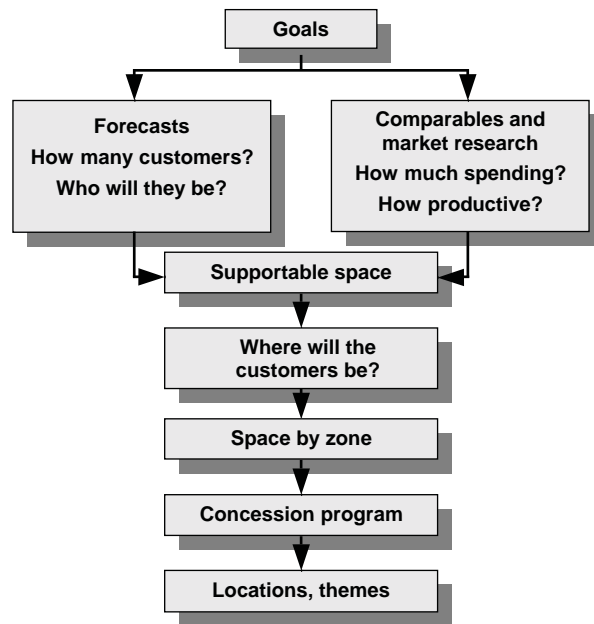

Source: LeighFisher.

**Figure 5-1. Concession planning methodology flow chart.**

Although minor variations exist, the general approach to concession planning at airports is common throughout the industry, involving considerations of traffic volumes, customer characteristics, location of customers in the terminal, amounts they can be expected to spend, and anticipated sales per square foot and per enplaned passenger. The key objective in a structured approach is to determine the supportable concession space in each area of the terminal. Supportable space is the amount of concession space that is financially viable for both the airport operator and the concessionaire. It is determined for the planning year by estimating concession sales at reasonable levels of productivity using sales per square foot.

The methodology of concession space planning as described in this chapter is illustrated conceptually in Figure 5-1. Each element of the structured approach to concession space planning is examined in the sections that follow.

### 5.1.1 Supportable Concession Space

There is strong correlation between the amount of concession space at an airport and customer spend rates. Figure 5-2 presents a scatter diagram showing the strong correlation between space and spend rates for a number of large and medium hub airports, using concession space per 1,000 enplaned passengers on one axis and the combined food and beverage and retail spend rates on the other axis.

The concession-space-to-passenger-spend-rate ratios shown in Figure 5-2 are quantitative, and do not reflect qualitative characteristics of the space or the passengers using these terminals. Unlike other characteristics of a concession program, such as the tenant mix, the amount of concession space to be provided is an investment decision with long-term implications, especially for new or refurbished terminals, where the cost of providing more concession space or reconfiguring existing terminal space to increase concession space allocations may be prohibitively expensive.



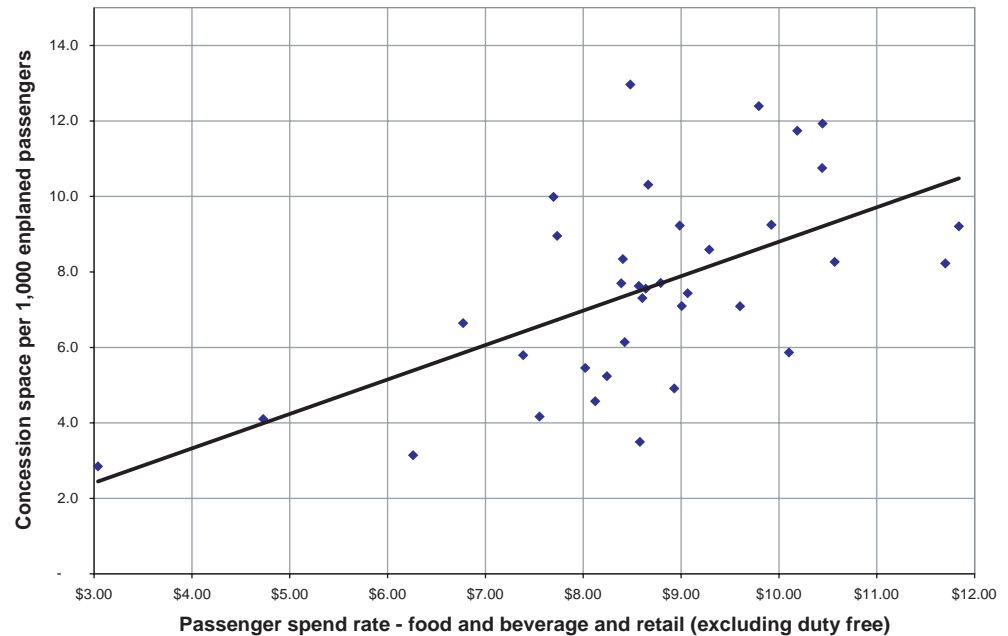

Source: LeighFisher. Data from *Airport Revenue News Fact Book 2009* (Airport Revenue News 2009).

**Figure 5-2. Relationship between concession space and sales—2008.**

### 5.1.2 The Customers

Passengers are the core customers for concessions. Within the passenger category of customers, however, there are subdivisions with very different characteristics—originating, terminating, connecting, international, and domestic. As described in Chapter 4, passenger spends vary by passenger characteristics, including the following:

- **Passenger residence and nationality.** Nonresidents typically spend more at an airport than residents. As nonresidents include tourists, these travelers are more likely to purchase local souvenirs and gifts, generating greater sales volumes for the retail program. Certain nationalities also spend more than others.
- **Originating passengers.** Originating passengers typically spend more time in the terminal than connecting or terminating passengers and tend to spend more.
- **Dwell time.** International passengers typically spend more time in the terminal than domestic passengers and spend more money on both food and retail.
- **Trip length.** Long-haul passengers typically travel in a relaxed and leisurely vacation mode. They tend to be away from home longer and therefore are more likely to make purchases for family and friends. Long-haul travelers usually spend considerable time in the terminal, creating enhanced opportunities to frequent retail shops and restaurants.
- **Leisure travelers.** Leisure travelers, compared to business travelers, prefer to arrive earlier at the airport; these passengers often represent the largest category of souvenir and gift buyers at the airport. They are more price sensitive and value oriented than business travelers.
- **Business travelers.** Business travelers tend to spend less time at airports and less time shopping. They are good customers for convenience retail (newspapers, magazines) and for food and beverage services, including alcoholic beverages and higher-quality restaurants. Business passengers, often traveling on expense accounts, are less price sensitive and more service oriented than leisure travelers. Business passengers may also be good customers for so-called “guilt gifts” for spouses and children.
- **Frequent flyers.** Generally, the more frequently passengers travel, the less time they are likely to spend in the terminal building, and their propensity to spend is lower.

- **LCC passengers.** Passengers on LCCs often spend as much or more than passengers on legacy airlines. Airport surveys indicate that LCC passengers do not necessarily spend less than legacy airline passengers in duty free and specialty retail units and are likely to spend more on food and beverages.
- **Spend per enplaned passenger.** Of the airport operators surveyed, 81% reported that they use the spend per enplaned passenger metric for planning and for evaluating concession performance (100% of concessionaires indicated this as well).

### 5.1.3 Passenger and Other Customer Group Spend Rates

Figure 5-3 summarizes the average food and retail passenger spend rates by hub size at 93 airports for which data are provided to *Airport Revenue News*.

For both food and retail, there is a pattern of increased spending with increased airport size. The factors behind this pattern include more supportable offerings as traffic grows (more choices in food and retail) and increased numbers of long-haul travelers in the mix at larger airports.

There are large variations in spend per enplaned passenger from airport to airport, even within each hub category. Table 5-1 summarizes the average spend and the 95th percentile upper limit (two standard deviations) by concession category and airport size. Airports that generate sales above two standard deviations from the mean are likely to have exceptional characteristics that make for an unreasonable comparison. For example, in 2008, Pittsburgh International Airport produced the nation's highest specialty retail spend rate of \$6.49, twice that of the next highest performing airport, due to a combination of factors that included terminal configuration, concentrated passenger flows, and the expertise and contracting flexibility of a third-party developer. In categories other than specialty retail, however, the airport's performance was within two standard deviations and would be reasonable for comparison.

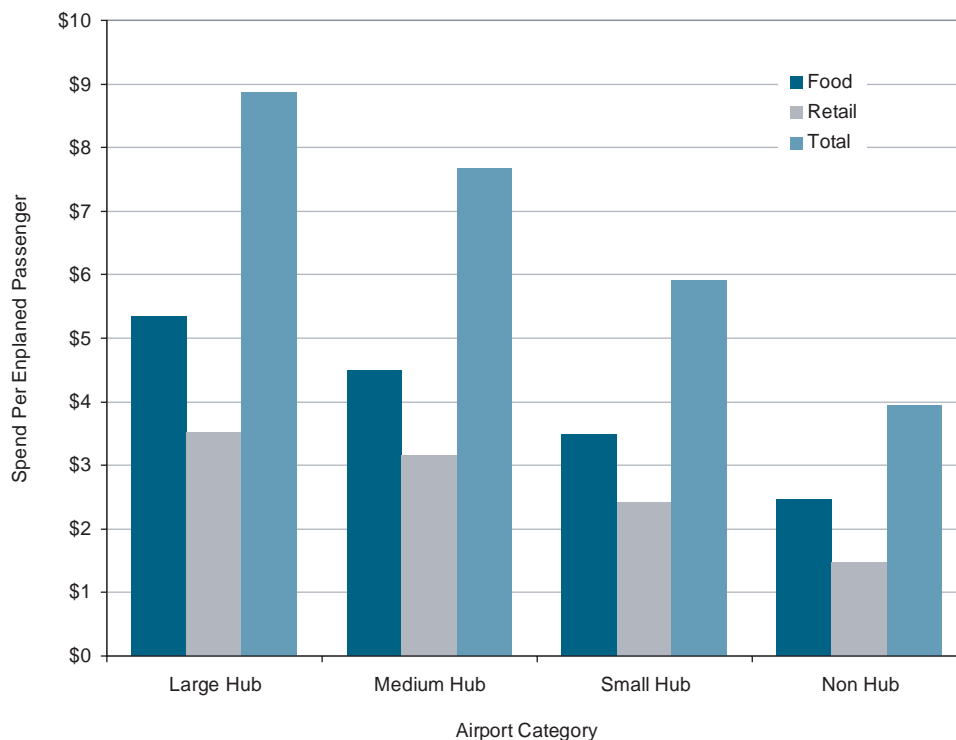

Source: LeighFisher. Data from *Airport Revenue News Fact Book 2009* (Airport Revenue News 2009).

**Figure 5-3. Average food and retail concession spending per enplaned passenger by airport category—2008.**

**Table 5-1. Average and upper 95th percentile range of concession spending per enplaned passenger by airport size category—2008.**

Category	Small Hub		Medium Hub		Large Hub	
	Average	95%	Average	95%	Average	95%
Food and beverage	\$3.49	\$5.37	\$4.50	\$5.97	\$5.34	\$7.39
Convenience retail	\$2.17	\$3.65	\$1.95	\$3.24	\$1.88	\$3.06
Specialty retail	\$0.27	\$1.03	\$1.21	\$3.87	\$1.71	\$4.20
Total retail	\$2.42	\$3.90	\$3.15	\$7.11	\$3.53	\$6.20
Total food and beverage and retail	\$5.92	\$8.46	\$7.66	\$11.29	\$8.87	\$12.79
Duty free	\$0.00	\$0.00	\$4.98	\$16.66	\$7.05	\$16.29

Note: At the 95% percentile passenger spend rates are independent. Performance in each category is independent of performance in other categories.

Source: LeighFisher. Data from *Airport Revenue News Fact Book 2009* (Airport Revenue News 2009).

As Table 5-1 shows, the variation in spending per enplaned passenger within each airport size category is smallest (as a percentage) for food. Specialty retail shows high variations from airport to airport, which is to be expected as some older terminals have very limited airside retail programs, and the terminal configurations preclude easy expansion.

In addition to passengers, there are other customer groups at the airport, including those who accompany passengers to the airport or meet them there and airport and airline employees. Each of these customer groups has access to different parts of the terminal and has different spending characteristics.

Well-wishers and meeters/greeters accompany travelers to the airport to see them off or arrive to pick them up. More specifically, well-wishers are nonpassengers accompanying departing passengers into the terminal. Meeters and greeters are nonpassengers meeting and greeting arriving passengers and accompanying them in the terminal. The numbers of well-wishers and meeters/greeters vary widely from airport to airport. Typically, the ratio of well-wishers and meeters/greeters to passengers has declined over time, as flying has become more commonplace. Currently, these ratios are often in the range of 0.2:1 but can vary widely. There can be large variations from airport to airport in the ratio of well-wishers accompanying passengers to airports and meeters and greeters visiting the airport to meet an arriving passenger. International terminals typically have higher meeter/greeter and well-wisher ratios than domestic terminals.

Airport, airline, and other terminal employees use the concessions. Each airline operating from the terminal has its own set of employees, including check-in and ticket agents and cabin and cockpit crews. In addition, ground-handling, Immigration and Customs, and security staff are key components of the terminal's employees. These airline and airport employees represent a significant potential target market for airport retailers, particularly for the outlets that are easily accessible pre-security. Airports with street pricing or employee discounts and branded food court units generate higher employee spend rates. Estimating average spend per employee can be difficult. Often the numbers of daily average airline/airport employees in the terminal are not well known. Nonetheless, estimating this number is better than ignoring it. Employees can account for a significant percentage of food court sales at many airports.

Although spend per enplaned passenger is used as the yardstick, this unit number obviously varies by the type of customer, with arriving passengers, well-wishers, meeters and greeters, and employees typically spending far less than enplaning passengers. Customer surveys at a number of airports have indicated that the spending of enplaning passengers exceeds that of all other types of terminal users by a wide margin. Table 5-2 illustrates the typical spending of these groups as a

**Table 5-2. Range of per person spend rates of customer groups as a percentage of spend rates per originating/enplaning passenger.**

Customer Category	Food	Retail
Originating Enplaning Passengers	100%	100%
Deplaning Destination Passengers	0%–5%	0%–5%
Connecting Passengers	40%–60%	40%–60%
Well-wishers/Meeters and Greeters	30%–40%	30%–40%
Employees	10%–20%	5%–10%

Employee spend is the average per employee workday.  
Source: LeighFisher from airport customer surveys.



percentage of the spending of originating/enplaning passengers (in other words, each customer category is presented as a percentage of the spending of enplaning/originating passengers). Note that the *average* spend per enplaning passenger is the sum of spending by all customer categories divided by the total number of enplaning passengers at the airport. Therefore, the overall average spend rate per enplaning passenger may be higher or lower than the average spend rate per for only originating/enplaning passengers when connecting passenger spending and non-passenger spending by meeters and greeters, well-wishers, and employees is taken into account.

One additional factor in determining spend per enplaning passenger is the performance of the existing concession program. A concession program that is too small, contributing to crowding in restaurants and shops, or a program that does not meet customer needs will have a lower spend per enplaning passenger than a successful program.

#### 5.1.4 Space per 1,000 Enplaned Passengers

Space per 1,000 enplaned passengers is a standard metric used for comparing concession space within and between airports. Figure 5-4 shows the average space per 1,000 enplaned passengers for a range of enplaned passenger levels. Figure 5-4 also shows the reported space in square feet for each major concession category. The ratio of concession space to enplaned passengers generally falls as passenger traffic volumes increase.

Figure 5-5 shows the data provided in Figure 5-4 expressed as a percent of the total available space for airports within the same ranges of enplaned passengers. As passenger levels increase, the share of total space devoted to convenience retail decreases, while the share of space devoted to specialty retail increases. The share of total space devoted to food and beverage is fairly constant, except for airports with numbers of annual enplaned passengers lower than one million, where the share of space devoted to food and beverage increases to nearly 75% of all concession space.

An important step in determining the amount of supportable space is forecasting spend rates per enplaned passenger by concession category—food/beverage, convenience retail, specialty retail, and duty free. These spend rates are typically forecast using the following:

- Customer surveys (passengers, employees, well-wishers, and meeters and greeters) on current spending habits, desires, dwell times, etc.
- The performance of existing concession units in terms of spend rates per enplaned passenger and sales per square foot
- The performance of concessions at airports with terminals of similar size and passenger mix
- The concession planners' experience in achieving increases in spending rates at other airports



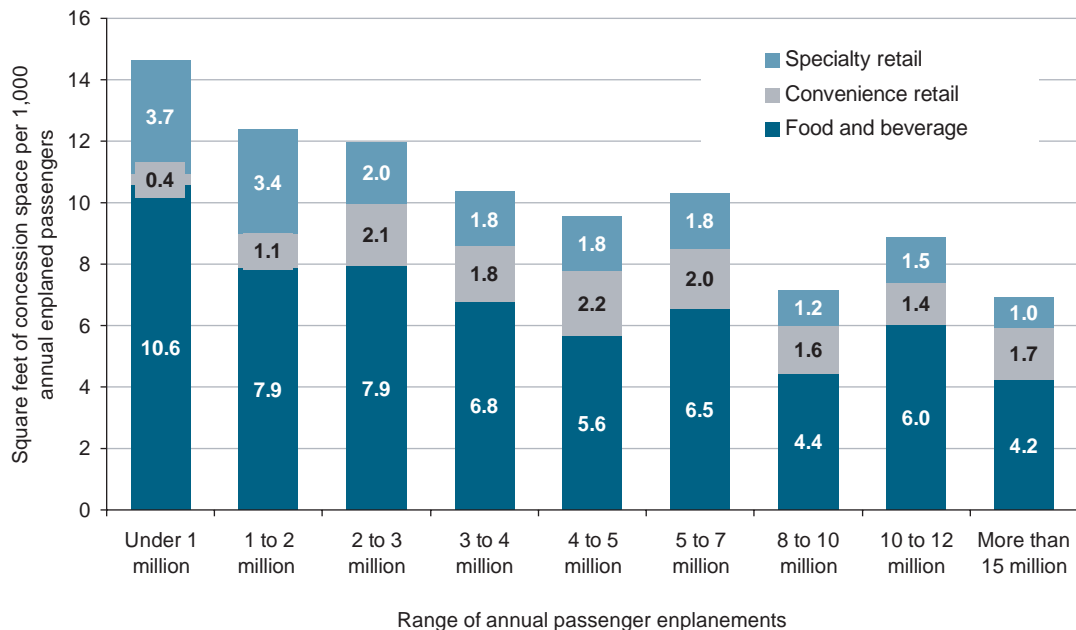

Source: LeighFisher. Data from *Airport Revenue News Fact Book 2009* (Airport Revenue News 2009).

**Figure 5-4. Space per 1,000 enplaned passengers by major concession category—2008.**

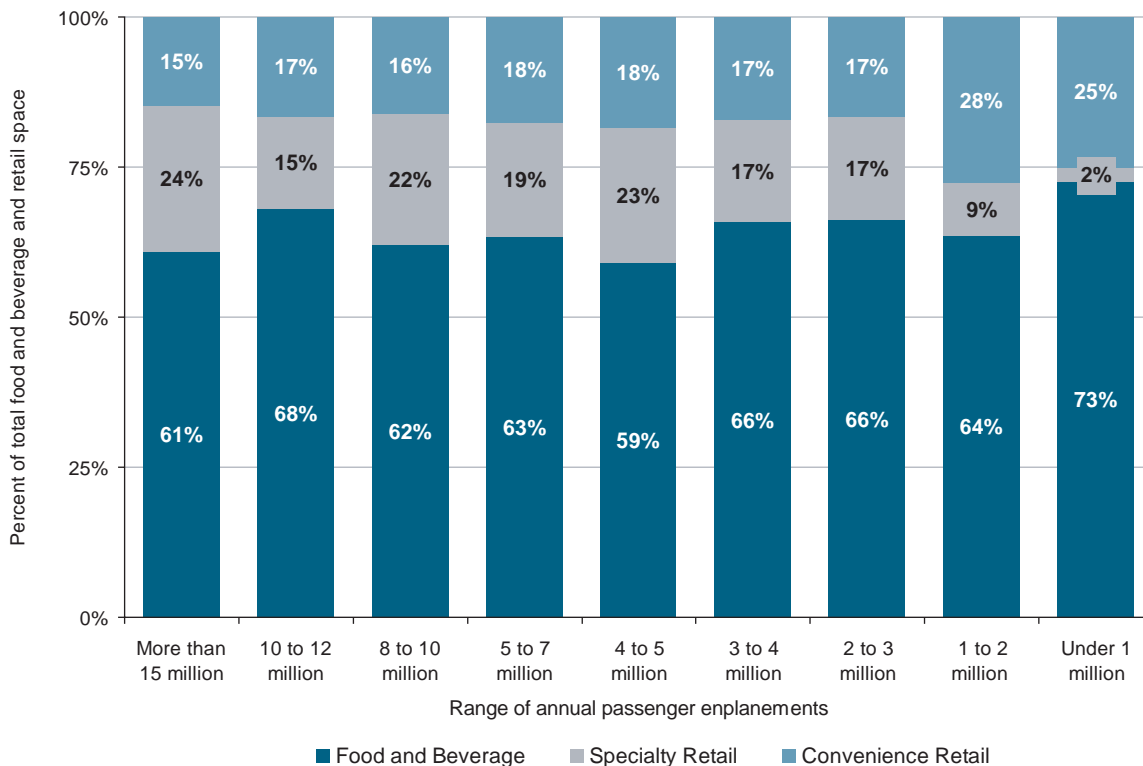

Source: LeighFisher. Data from *Airport Revenue News Fact Book 2009* (Airport Revenue News 2009).

**Figure 5-5. Percentage of space by major concession category—2008.**

### 5.1.5 Productivity per Square Foot

The productivity, or spend, per square foot is a planning number required to determine supportable space. The productivity factor is the sales per square foot for each concession category that would provide a reasonable return for both the airport operator and the concessionaire. A number that is too low will result in too much space. It is important to select a productivity number that will result in a suitably sized concession program in the planning year. A number that is too high will result in space requirements that are understated. Of airport operators and concessionaires surveyed for this research project, 70% and 71%, respectively, indicated that they monitor sales per square foot.

As concessions become heavily used, they lose sales at some point because customers see that the units are congested. Many passengers will not wait in line to make a purchase, particularly if it is a discretionary purchase.

The specific productivity planning number selected for an airport concession program will be a function of the following:

- **Airport size.** Large hub airports will tend to have higher productivity numbers than smaller airports. The operators of smaller airports tend to make decisions to have a reasonably sized food and news/gift program that may result in low productivity.
- **Peaks in passenger traffic.** At airports with high daily peaks relative to total daily traffic, low productivity numbers should be used for planning purposes to avoid overcrowding and lost sales during peaks.
- **The ability to provide space.** For some renovations of existing terminals, airport operators need to use high productivity numbers for planning purposes, simply because insufficient space exists to allow the use of lower numbers.

Figure 5-6 illustrates the average productivity levels per square foot for food and retail for each airport size category. Average or current productivity may not be appropriate for use in determining supportable space, as many terminals are undersized relative to current demand.

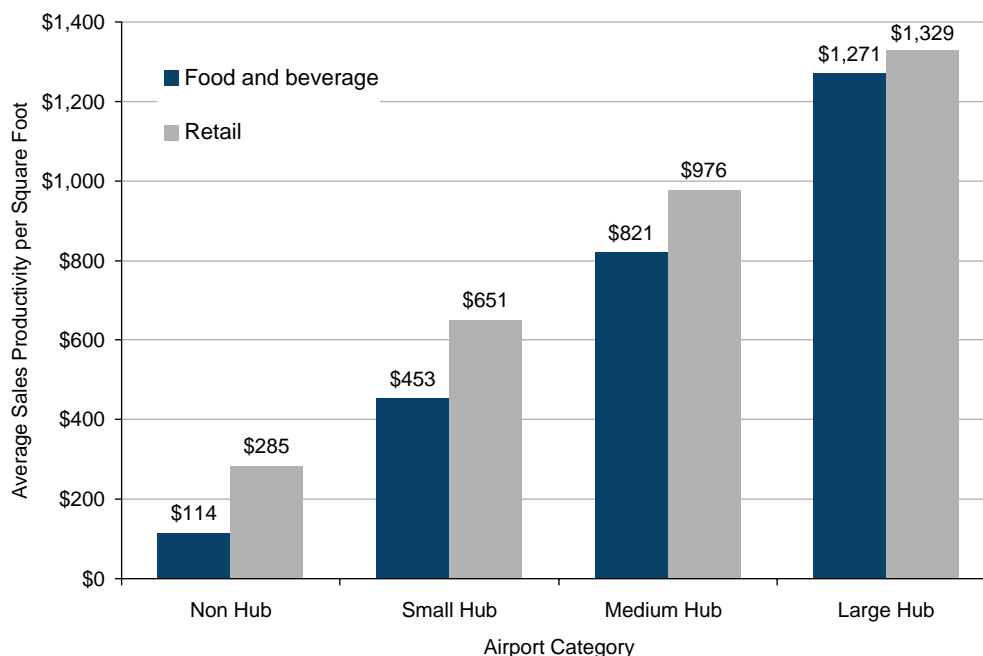

Source: Airport Revenue News 2009.

**Figure 5-6. Average food and retail productivity by hub size—2008.**

**Table 5-3. Recommended range of productivity for planning (sales per square foot).**

Concession Category	Range of Sales per Square Foot			
	Non Hub	Small Hub	Medium Hub	Large Hub
Restaurants/food courts (incl. seating)	\$100 – \$200	\$400 – \$700	\$800 – \$1,300	\$1,250 – \$2,000
Retail	\$300 – \$600	\$650 – \$1,200	\$1,000 – \$1,600	\$1,300 – \$2,000
Duty free			\$500 – \$1,700	\$2,200 – \$3,600

Source: LeighFisher.

The increase in productivity with airport size is not a factor that has been well discussed in the industry. Using a productivity factor appropriate for a small hub airport at a large hub airport would not account for the high labor and operating costs and higher investment requirements at large hub airports. Conversely, use of high productivity numbers appropriate for large hub airports at smaller airports can result in programs that may be undersized, inefficient, and less productive.

Table 5-3 presents a summary of the range of productivity numbers recommended for use in planning. The high end of the ranges should be used if the terminal is space constrained. In some cases, a terminal may be incapable of providing the optimal amount of concession space indicated by the supportable space analysis. The lower end of the ranges is recommended for new terminals where flexibility is desired.

In selecting a productivity number for planning at smaller airports, some flexibility is required. For example, a calculation of forecast sales per square foot for a specialty operation at a small hub airport when combined with a typical productivity number may yield a shop that is unreasonably small. The planner needs to consider either eliminating the shop entirely and including a retail merchandising unit (cart) instead, or using a lower, yet still reasonable, productivity number to arrive at a shop footprint that makes sense.

One element that may cause confusion is that the productivity number used for planning may be lower than the current productivity at the airport. High sales per square foot do not, in themselves, indicate a successful concession program. As sales per square foot increase to a level well beyond recommended levels, spend rates per enplaned passenger and total concession sales will be lower than they could be with sufficient space as sales may be lost during peak or busy periods. Figure 5-7 illustrates this point conceptually.

Table 5-4 shows the five large hub airports with the highest sales per square foot among the 25 large hub airports for which data were submitted for the *Airport Revenue News Fact Book 2009* (Airport Revenue News 2009). The airport with the highest sales per square foot, Chicago O'Hare International Airport, ranked 16th overall in passenger spend rate. Hartsfield-Jackson Atlanta International Airport ranked 3rd in sales per square foot, but 22nd out of the top 25 airports reporting data in sales per enplaned passenger. Both airports are among the most challenged in terms of providing concession space to meet demand and could undoubtedly produce higher average sales per enplaned passenger (and revenue per enplaned passenger) if more space were available for concessions.

### 5.1.6 Optimum Productivity

The optimum productivity is the highest amount of space consistent with not losing a sale as a result of congestion. Unfortunately, a mathematical model cannot be used to determine the perfect number. The optimum productivity varies by airport and by concession type. As traffic grows, sales can be lost due to congestion during peak periods, when passengers may bypass a



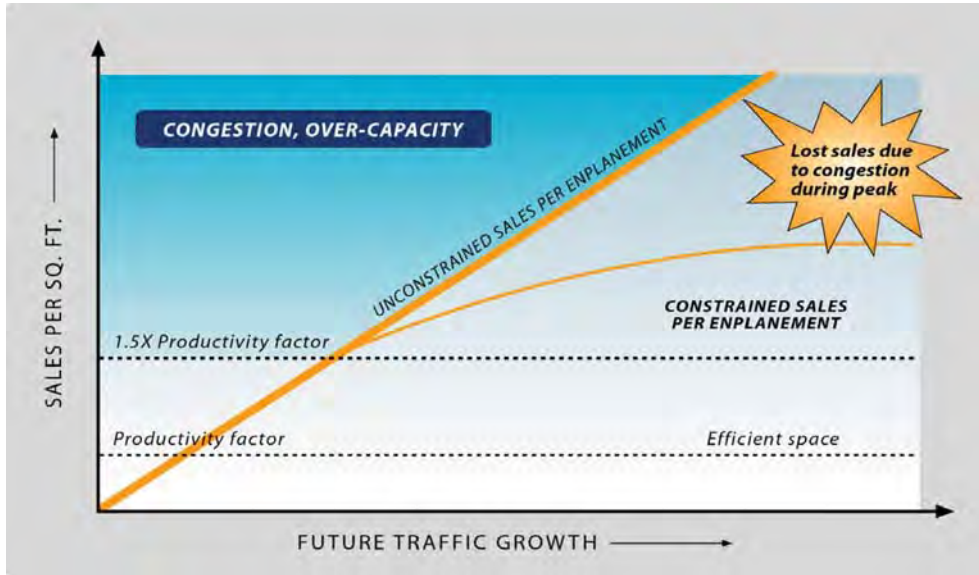

Source: "Space Plan for Tom Bradley International Terminal," unpublished, prepared by LeighFisher, 2010.

**Figure 5-7. Effect of congestion on spending per enplaned passenger.**

concession rather than wait. At an airport with relatively high daily flight peaks, sales will start to be lost from congestion effects at a lower average productivity than at an airport that has relatively even traffic throughout the day. This is particularly important at connecting hub airports, where passengers changing planes may have limited time after locating their departure gates.

When concession space is limited, sales will vary depending on the type of concession. Some effects of limited concession space on food, convenience, and specialty and duty free concessions are the following:

- People are more likely to queue for food, so sales at undersized food units may continue to increase. However, some sales will be lost as the units become more crowded and customers are turned away. The level of passenger service deteriorates over time.
- At convenience units, people will tolerate some congestion and small queues for payment, but, in general, these units are more sensitive to undersizing (the optimum productivity point exceeded) than food or bar units.
- Specialty and duty free products are impulse buys, and if the unit looks to be difficult to navigate because people with towed luggage are in many areas of the unit, or if there is a substantial queue for payment, sales are certainly lost. With high-end merchandise, customer service expectations may also increase as the amount of the purchase increases.



**Table 5-4. Comparison of sales per square foot and sales per enplaned passenger for selected large hub airports.**

Airport	Average sales per square foot	Rank among top 25 airports <sup>(1)</sup>	Sales per enplaned passenger	Rank among top 25 airports <sup>(1)</sup>
Chicago O'Hare International Airport	\$ 2,453	1	\$ 8.58	16
Los Angeles International Airport	\$ 1,817	2	\$ 8.93	12
Hartsfield-Jackson Atlanta International Airport	\$ 1,812	3	\$ 7.55	22
Charlotte Douglas International Airport	\$ 1,775	4	\$ 8.12	23
Las Vegas McCarran International Airport	\$ 1,721	5	\$ 10.10	5



<sup>(1)</sup> Top 25 large hub airports submitting data for *Airport Revenue News Fact Book 2009* (Airport Revenue News 2009).

**Table 5-5. Customer propensity to wait, level of service requirements, and range of transaction values by concession type.**

Category	Propensity to Wait	Required Level of Service			Indicative		
		Low	Medium	High	Range of Transaction Values		
Restaurant	High		✓	✓	\$12	to	\$25
Specialty coffee	High	✓			\$2	to	\$5
Bar	Low		✓	✓	\$7	to	\$12
Quick-serve	High	✓			\$5	to	\$10
Convenience retail	Moderate		✓		\$1	to	\$15
Specialty retail	Low		✓	✓	\$10	to	\$100
Duty free							
Perfume & cosmetics	Low			✓	\$30	to	\$300
Liquor & tobacco	Moderate		✓		\$20	to	\$125
Confectionery	Moderate		✓		\$20	to	\$75
General merchandise	Moderate			✓	\$20	to	\$1,000
Fashion	Low			✓	\$50	to	\$5,000
Jewelry and watches	Low			✓	\$200	to	\$20,000
Fashion boutiques	Very Low			✓✓	\$100	to	\$5,000

Source: LeighFisher.

Table 5-5 provides a summary of the propensity of customers to wait and other key decision factors that affect productivity.

### 5.1.7 Benchmarking of Concession Space



Once the amount of supportable space has been estimated, it may be useful to benchmark the estimated space against such space at other airports and contact peer (comparable) airports to discuss their planning standards. At Dallas/Fort Worth International Airport, for example, a planning standard of 10 square feet per 1,000 enplaned passengers has been adopted.

In setting planning standards, such factors as the following should be taken into account:

- The efficiency of a terminal in terms of concentrating passenger flows
- Exposure to passengers
- The allocation of space pre- and post-security to reflect customer demand
- Configuration of the space in terms of frontage and depth preferred by concessionaires
- Passenger/customer characteristics
- Clustering of concessions to create desirable retail density

Figure 5-8 provides the concession floor areas per 1,000 enplaned passengers for selected airports and, for comparison, selected international terminals at U.S. airports, and some airports outside the United States to illustrate the range of concession space provided.

Caution should be exercised when using any airport as a benchmark. Many older terminals are space constrained. Using these terminals or a group of terminals that includes space-constrained terminals can result in unrealistic numbers. Similarly, concession units at some airports may be oversized relative to demand because of changes in airline service, an oversupply of pre-security space, the number of security checkpoints and separate passenger flows, or other factors. For these reasons, use of a detailed supportable space analysis that indicates concession space by terminal zone is recommended over a rule of thumb or comparison with other airports.

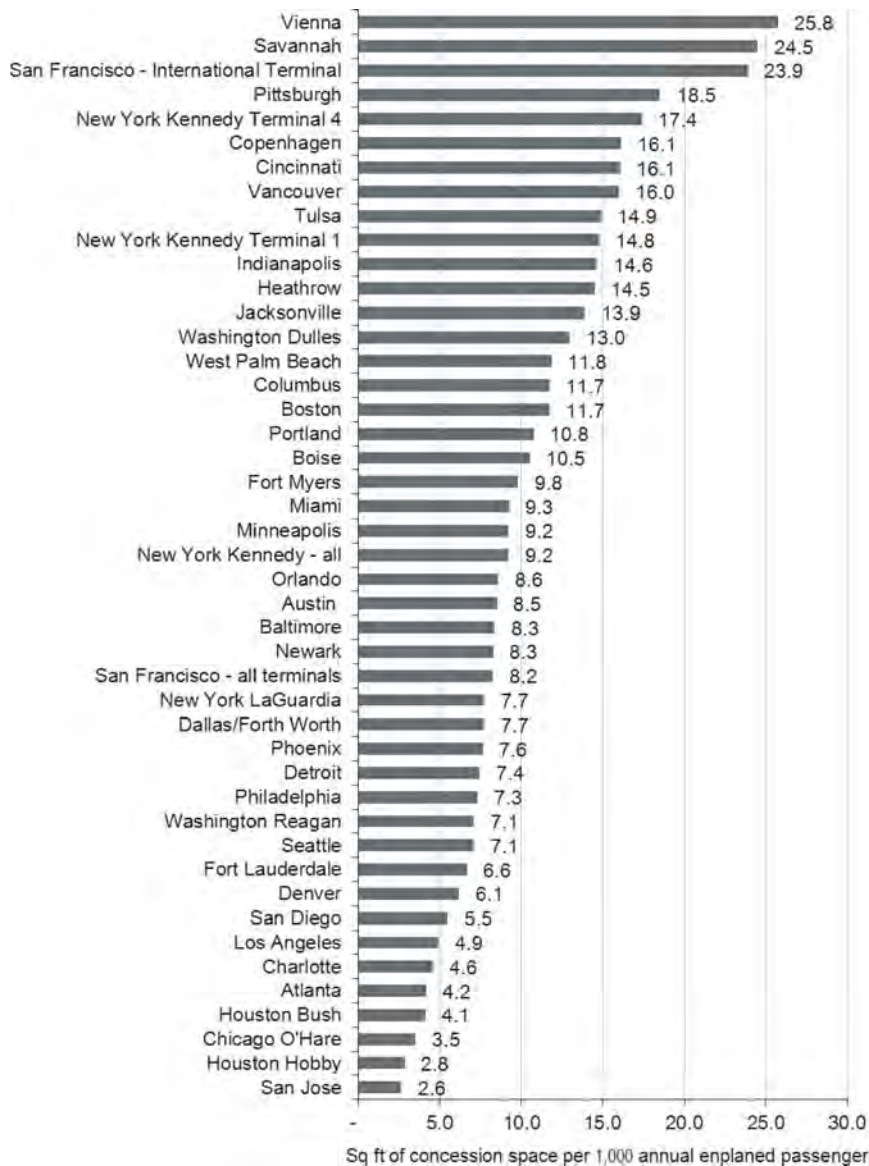

Source: LeighFisher. U.S. airport data from *Airport Revenue News Fact Book 2009* (Airport Revenue News 2009).

**Figure 5-8. Comparison of concession space per 1,000 enplaned passengers for selected airports and international terminals—2008.**

### 5.1.8 Where Will the Customers Be?

With the amount of supportable space in the terminal determined, the next step is to allocate this supportable space to the optimum locations. The first step in this allocation process is to determine where the customers will be in the terminal. Passenger volumes diminish as the distance from the central core increases and the passenger flow is split to the terminal concourses. The approach to determining customer locations is to split the terminal into zones. The actual number of zones depends on the size of the terminal, but a typical subdivision into zones includes the following:

- Landside departures
- Airside core area departures
- Airside concourses
- Airside arrivals
- Landside arrivals

**Table 5-6. Example of determining traffic by zone (annual customers in the planning year).**

Terminal Zones	Transit passengers	Enplaned passengers	Deplaned passengers	Well-wishers	Meeters and greeters	Employees (workdays)
Transit lounge	275,000	—	—	—	—	—
Landside	—	5,500,000	—	1,100,000	—	180,000
Airside core	—	5,500,000	—	—	—	90,000
Departures lounge south	—	2,970,000	—	—	—	—
Departures lounge north	—	2,035,000	—	—	—	—
Baggage claim	—	—	5,500,000	—	—	—
Arrivals lobby	—	—	5,500,000	—	1,100,000	45,000

Note. Dashed lines indicate no value.

Each concourse would represent one or more zones. Where a terminal has multiple traffic sectors (domestic, international), zones are typically developed for each area within each traffic sector. Table 5-6 presents an example of how customer volumes are determined by zone.

It is frequently useful to create traffic density diagrams to present the traffic volumes visually. Figure 5-9 is an example of this type of diagram. The determination of where customers will be and the visual presentation of this information can prevent a frequent error in concession planning—the provision of excessive concession space where traffic volumes are low, such as at the end of concourses.



The forecast supportable space can be determined by multiplying the expected spend rate in each area of the terminal by the number of potential customers using each area. This produces an estimate of gross sales by area of the terminal. Dividing these estimated gross sales by the productivity factor illustrated in Table 5-3 produces the concession space by category for each zone of the terminal. Table 5-7 presents space allocations by zone and category based on estimates of customers in each zone and spend rates in each zone.

At this stage in the concession program development, individual units are not yet sized, but space by category can be determined within each zone. Table 5-7 is an example of space allocation to each zone by category. Allocations representing small amounts of space may not be viable.

It may not be possible to provide the optimal amounts of space in each zone of the terminal. In older terminals, or terminals operating at high levels of passenger activity relative to their

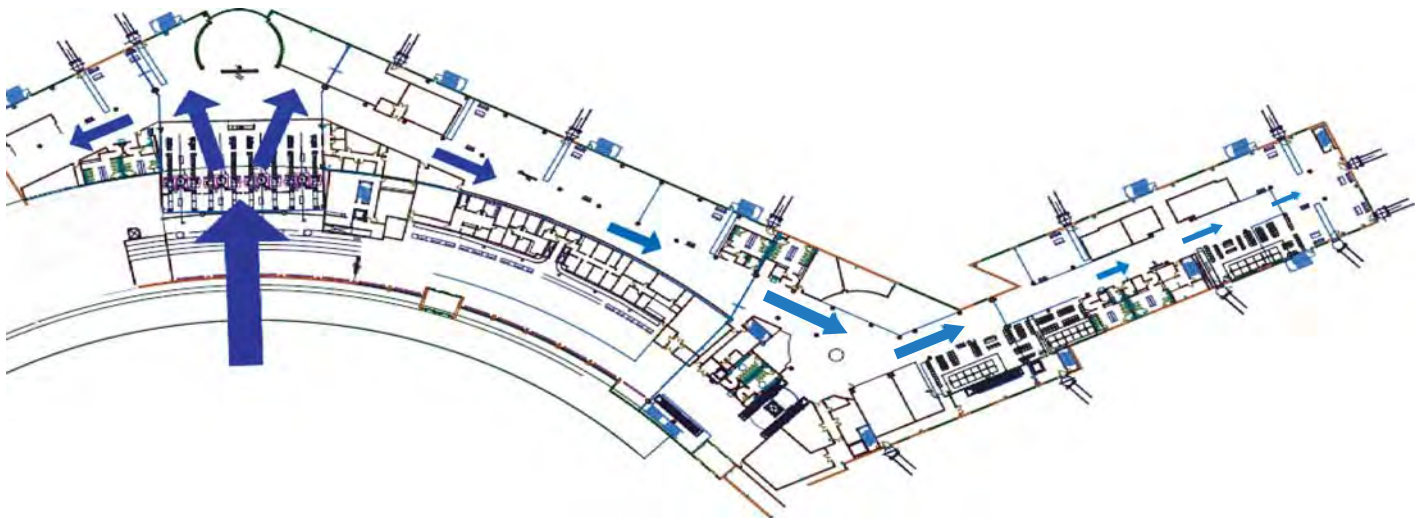
**Figure 5-9. Example of traffic density diagram.**

**Table 5-7. Example of concession space allocation by zone and category.**

Terminal Area	Food and beverage	Convenience retail	Specialty retail	Duty free	Services	Total
Transit lounge	742	160	–	510	–	1,412
Landside departures	9,616	1,100	–	–	63	10,779
Airside core	14,253	5,516	5,113	21,197	402	46,481
South concourse	1,524	917	–	582	–	3,023
North concourse	1,044	628	–	399	–	2,071
Baggage claim	–	–	–	–	48	48
Arrivals lobby	2,455	456	–	–	47	2,958
Total	29,634	8,777	5,113	22,688	560	66,772

design capacity, providing optimal amounts of concession space may be impossible. Nevertheless, performing a supportable space analysis will help concession planners understand the relative magnitude of the shortfall, identify areas where additional concession space may be viable, and provide inputs for future terminal planning studies.

## 5.2 Supportable Concession Units Based on Traffic Levels

Within the framework of the supportable space, determining the types, numbers, and sizes of individual concession units is a function of passenger traffic and the practical sizes for concession units. The scale effect can most easily be understood by considering very small local airports. Typically, the concession program at these airports consists of a single food outlet and a newsstand, possibly one with some gift items such as T-shirts. Considering the low traffic levels at very small airports, specialty retail and service offerings are seldom viable. As traffic levels increase, thresholds are reached at which multiple food offerings and specialty retail offerings are supportable. For example, of the small hub airports in the survey conducted for this research project, 70% reported that they had food courts with multiple units. This percentage increased to 87% for medium hub airports.

At larger airports, multiple convenience retail and food offerings become essential as walking distances to gates increase. Table 5-8 presents an estimate of the enplaned passenger levels necessary to support various types of concessions. Duty free is an unusual category in that, if the airport offers international flights, duty free offerings can be provided by mobile units at very low traffic levels because of the high margins inherent in duty free sales.

Also of interest is that the *Airport Revenue News Fact Book 2009* data appear to show an approximately 10% “cannibalization” or reduction of convenience retail spending where a significant

**Table 5-8. Estimated minimum enplaned passenger levels to support concession units.**

Concession Type	Enplaned passengers	Range of Unit Sizes (square feet)
Specialty Retail Units <sup>1</sup>	400,000	800–2,000
Three Unit Food Court <sup>2</sup>	900,000	1,500–2,400
Five Unit Food Court <sup>1</sup>	1,600,000	1,500–2,400
Multiple News/Gift Units	450,000	800–2,400

1. Excluding retail merchandising units (kiosks).

2. Including seating area.

Source: LeighFisher using data from the airport surveys conducted for ACRP Project 01-11.





specialty program has been introduced (Airport Revenue News 2009). This likely reflects competition among concession units as well as a shift in sales of some items in newsstands or news/gift shops to specialty retail shops. Overall, specialty retail programs add incremental revenue in the retail category.

### 5.3 Sizing of Concession Units

The dimensions of concession units are often determined by the basic terminal configuration. In concourses, holdroom depths are usually at least 30 feet, and concessions occupy the same depth of space between the central corridor and the exterior walls.

In areas such as a large central core space, where the terminal dimensions do not drive concession depths, the preferred approach is to keep retail concessions shallow (25 feet to 30 feet in depth) and wide. This approach maximizes the passenger's exposure to the shop. Unlike customers at shopping centers, airport customers aren't at airports to shop, so spontaneous purchases are more important, and these are generated through exposure, which is maximized by wider shop fronts.

### 5.4 Location Criteria

The location of the concession program has a dramatic effect on sales and customer satisfaction. Location issues consist of the following:

- Pre-security versus post-security split
- Concentration into concession zones versus dispersion
- Contiguous concession spaces versus interruption of concessions
- Flow-past versus flow-through concession areas
- Departures level versus mezzanine level concessions

Each of these criteria is discussed in the sections that follow.

#### 5.4.1 Pre-Security versus Post-Security Split

With implementation of passenger security screening, the location of the concession offerings became an important issue because of the following:

- Almost the entire concession program at many older terminals was in areas that became pre-security.
- With ever-more-stringent screening processes, the percentage of passengers who return to pre-security areas after screening continues to decrease.
- Well-wishers are not permitted airside and, because of both security and processing capacity issues, are unlikely to be permitted post-security in the future.
- Dwell times have increased post-security and decreased pre-security.

Although queue times for security processing have typically improved since the security inspection changes were implemented in response to the attacks of September 11, 2001, the uncertainties regarding queuing time still mean that, for most passengers, anxiety remains high until they have passed through the screening checkpoint. Passenger surveys indicate that dwell times are often longer than estimated by airport management and that passengers are anxious to clear security. The uncertainty of queuing and processing times at the security screening checkpoint means that passengers' propensity to use concessions is much lower pre-security than post-security.

**Table 5-9. Percentage of concession space and concession sales pre- and post-security.**

Concession Location	Percent of Concession Space	Percent of Concession Sales
Pre-Security	31%	24%
Post-Security	69%	76%

Source: LeighFisher using data from the airport surveys conducted for ACRP Project 01-11.

While passenger attitudes are difficult to survey, many surveys capture passenger responses to their dwell times pre-security and post-security; the evidence indicates that passengers typically migrate to the post-security area as soon as they can. Passenger surveys at 10 airports that included dwell time questions indicated a range of total dwell times between 83 minutes and 165 minutes (average of 109 minutes), of which an average of 60% was spent post-security. For these airports, passengers finished all processing except boarding and had more than an hour to spend post-security on average.

At a few airports, passengers may arrive early due to tour group movements, early hotel check-out times, or cruise ship schedules. Airline ticket counters may not be open or airlines may not be able to accept checked baggage several hours before departure time. At international terminals, small airlines may not be open for early check-in. This may require some passengers to remain in pre-security areas and may increase demand for pre-security concessions.

In the current more stringent security environment, many airport operators have been relocating the majority of their concessions post-security as terminals are modified or expanded. Table 5-9 summarizes the percentage of concession space and sales located pre-security and post-security for the airports surveyed for this research project.

Among the airports surveyed, post-security concession space is 43% more productive than pre-security concession space in terms of sales per square foot.

The airport concession managers surveyed for this research project indicated that they would prefer more of their concessions to be located post-security, as indicated in Table 5-10. The fact that the current and recommended percentages of concession programs located post-security increases with airport size is consistent with the increase in importance of retail as airports increase in size, and the fact that retail tends to be an impulse purchase that requires the passenger to have time and the appropriate frame of mind.

As indicated in Table 5-10, for the surveyed airports, the suggested post-security percentages of the total concession program are significantly higher than the post-security percentages

**Table 5-10. Current and suggested post-security allocation of concessions by airport size category.**

Airport Category	Percent Post-Security Today	Percent Post-Security Suggested
Small Hub	56%	68%
Medium Hub	69%	79%
Large Hub	76%	85%

Source: LeighFisher using data from the airport surveys conducted for ACRP Project 01-11.



currently found at many airports. Many older terminals were constructed before passenger screening procedures were expanded and simply lack the space post-security to accommodate a large concessions program.

Typically, as new terminals are built or major expansions are undertaken, the concession program is substantially shifted to post-security locations. The operator of Manchester Airport in the United Kingdom, as an extreme example, has implemented a 100% post-security program on the departures level, with the only pre-security concession units on the arrivals level. Most airport operators, however, want to retain some departures level pre-security concession facilities, primarily to provide the opportunity for passengers to spend time (and money) with their well-wishers. Pre-security units tend to be predominantly food and convenience retail.

Examples of airports with very large pre-security concession programs do exist, but in these examples, such as Amsterdam Airport Schiphol, the airport terminal also serves as a commuter hub for locals transiting from the airport neighborhood to the city core. Not many airports share this characteristic.



Terminal 4 at Phoenix Sky Harbor International Airport has a sizable pre-security concession program consisting of approximately 38,000 square feet of leased space. According to the airport's concession manager, the pre-security program was developed because (1) the volume of departing passengers using the terminal is triple what was originally planned and (2) the amount of concession space post-security is very limited and cannot be expanded. The pre-security concession program helps satisfy some of the demand that cannot be accommodated by the post-security concessions and, by meeting some of the demand of originating passengers, frees capacity for use by connecting passengers, particularly during traffic peaks.

Another example of a large pre-security concession program is the privately developed Terminal 4 at John F. Kennedy International Airport, which has a large central pre-security concessions hall. Although the program is successful, the terminal owner plans to relocate the main security checkpoint so that the concessions area will be post-security and anticipates increased spend rates as a result.

#### 5.4.2 Concentration into Concession Zones versus Dispersion

In older terminals, concession programs, particularly post-security concessions, often appeared to be fit into available space, resulting in a scattered program. As the focus on commercial revenues and passenger services has increased, there has been a move toward creating concession zones with a concentration of concessions, décor, and floor treatment that differentiate these zones from other areas of the terminal.



In developing a concession program, the following should be taken into consideration:

- **Convenience and location of the proposed concession program.** One of the most important success factors in retailing is convenience. Clearly, the location of concessions within the terminal is crucial.
- **Locations within passenger flows.** Fundamental to designing a successful concession program is ensuring that units are positioned along natural passenger flow paths.
- **Centralization.** Passengers prefer airport commercial retail facilities that are convenient, concentrated, and well positioned. In fact, a concentrated, well-placed, central concession area will greatly influence the economic viability of the terminal's concessionaires. Shops give life to each other. Therefore, it is important that the locations are well considered and that the right shops are placed in the right clusters, creating a critical mass of outlets forming a "retail street." Concentration, also referred to as retail density, is important, as experience has shown that retailers will perform best when commercial concessions are highly visible, placed in the

direct flow of high traffic areas, and clustered together to form a critical mass in complementary adjacencies.

- **Visibility.** A prominently visible location for the majority of the concession program, typically immediately post-security, augmented by signage, flooring, and lighting treatments that clearly differentiate a shopping and dining zone, will increase the performance of the concession program.
- **Service.** In larger airports, where walking distances are long, food and news units should be located beyond the clustered concession zones. Typically, a distance of every four gates on a concourse with aircraft parked on only one side or every two gates where aircraft are parked on both sides of a concourse should be considered for food and news services, even if they are small and offer limited selection.

### 5.4.3 Contiguous Concession Spaces versus Interruption of Concessions

For maximum effect, a contiguous format for the concession program is recommended, with minimal interruptions to the physical flow of concessions created by operational features such as corridors, fire hoses, blank walls, utility rooms, columns, and restrooms. The benefits of creating a “sense of place,” design theme, and effective signage are enhanced by minimizing interruptions to the visual and physical flow of the commercial retail area.



### 5.4.4 Flow-Past versus Walk-Through Concession Areas

“Walk-through” concession areas as a strategy bring the product offering more directly to the traveler. Walk-through concession areas encourage the maximum number of passengers to buy something. Walk-through concessions versus flow-past concessions instantly increase passenger flows, and, the higher the passenger flows, the greater the opportunity to convert passengers into buyers (the capture rate) and the greater the opportunity to raise average spend per passenger and average transaction spend. There is always some tension between a complete, walk-through shopping and dining experience and the operational concerns of the airport operator. Figure 5-10 shows a walk-through concessions area, with security inspection indicated by the arrow. Once passengers have passed through the security checkpoint, they follow a serpentine



Source: BAA.

**Figure 5-10.** Example of flow-through concessions (London Heathrow Airport Terminal 3).

walkway through the large open-plan duty free space (indicated by the dotted line) leading to the common departure lounges and seating areas. Other retail and food and beverage spaces are clustered around the common seating areas, where passengers remain until their departure gate is posted, about 1 hour before departure.

Walk-through concession areas are increasingly prominent at major airports outside the United States where concession revenues, particularly retail, are major sources of revenue. Walk-through concessions also require an accommodating terminal layout and large, concentrated passenger flows.

#### 5.4.5 Departures Level versus Mezzanine Level Concessions



It is conventional wisdom that concessions should be on the enplaning level along major passenger flows and that placing concessions on a mezzanine level, as is common in Europe and Asia, will not work in the United States. Mezzanine level concessions at airports can be successful in certain circumstances with careful planning, as demonstrated at two major U.S. airports, Denver International Airport and Hartsfield-Jackson Atlanta International Airport, and at Calgary International Airport in Alberta, Canada. The mezzanine level concessions at these airports are predominantly food and beverage concessions—mostly casual dining restaurants seeking to attract passengers with longer dwell times, such as early-arriving originating passengers and connecting passengers with longer connect times.



At the Atlanta and Calgary airports, the mezzanine concessions are all casual dining units or food courts. At the Denver airport (see Figure 5-11), the mezzanine on the busiest concourse also includes some specialty retail shops that take advantage of the foot traffic from the mezzanine food/beverage concessions. These include two large casual dining units, a large smoking lounge with a bar, specialty coffee, ice cream, and a smoothie unit.

Successful mezzanine programs share common characteristics, including the following:

- Strong passenger demand that cannot be satisfied with the concession space on the departures level alone
- Placement of concessions in high-traffic areas at the center of the concourse, where the concentration of passengers is greatest (for most airports, the equivalent would be the area immediately post-security)
- Visible pairs of escalators offering easy access to and from the mezzanine level, which reduces the passenger's perceived risk of venturing off the departures level



**Figure 5-11. Mezzanine concessions (Concourse B, Denver International Airport).**

- Strong destination restaurant brands to help attract foot traffic
- Good visual access from the departures level to the concessions on the mezzanine level, with prominent signage

While mezzanine level concession development may be viable in some busy terminals where concession space demand is high, such development should be approached cautiously.

### 5.4.6 Appropriate Spaces

In developing appropriate locations for concessions, the following should also be considered:

- Restaurants and food court seating should be at the windows as much as possible to take advantage of natural light and airfield views.
- Kitchens should be in spaces with single-story ceiling heights. Ventilation in kitchens can be a significant issue—in many jurisdictions, lateral ventilation to an outside wall is not permissible.
- If locations are suitable, food units should have soft transitions into the holdroom areas.
- Duty free and specialty shops tend to be more successful when not located along an exterior open window wall, which reduces display areas.
- Specialty shops, convenience retail, and duty free boutiques function best if they are in spaces with conventional ceiling heights. High spaces work well for some food seating and can work for duty free general operations.
- Service corridors should be considered when locating kitchens and high-volume duty free operations (liquor, tobacco). This keeps deliveries, garbage, and trash out of sight of passengers and avoids soiling carpets and public spaces.



## 5.5 Adjacencies

Many concessions work better together. As a simple example, the creation of shopping opportunities immediately across a corridor from food court seating enables customers to see the shopping area while they are dining and enables family members to shop and return to the food court. Figure 5-12 illustrates adjacencies that can contribute to a successful concession program.

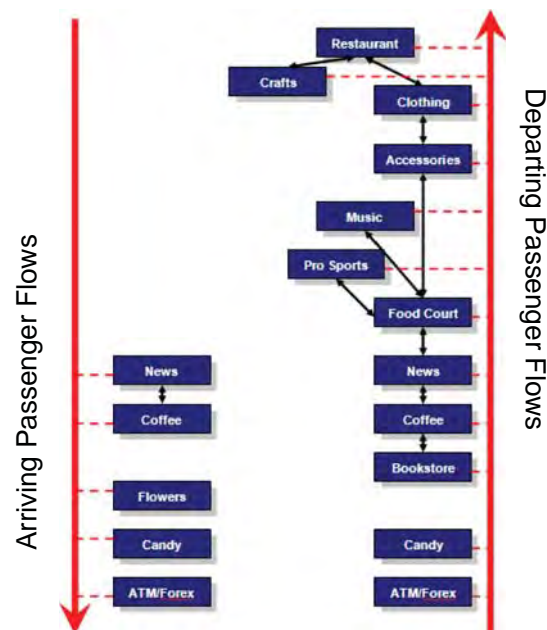

Source: LeighFisher.

**Figure 5-12.** Recommended concession adjacencies.

As a general rule, clustering concessions together increases exposure for all concessions, has greater pulling power, and creates a concession zone where all tenants benefit from proximity. Clustering concessions produces better overall performance compared with having concessions isolated along passenger flows.



Other commonly used adjacencies include locating newsstands and specialty coffee units adjacent to one another; grouping specialty retail together, often with a convenience retail to increase exposure and take advantage of the foot traffic created by convenience retail; taking advantage of traffic created by restrooms to increase exposure to passengers; and clustering quick-serve units together in food courts, which creates more of a destination and allows members of a traveling party to stay together while using different concessions.

## 5.6 International Terminals

The locations of concessions will differ in an international terminal where high-value concessions, such as duty free, should take precedence. The location, sizing, and configuration of the duty free concession need to be well planned to maximize sales. The following should be taken into consideration in planning for duty free concessions:

- According to a major international duty free concessionaire, experience at airports outside the United States has shown that a cash and carry duty free approach can achieve as much as 20% more sales compared to a gate delivery approach. Countries that permit cash and carry of duty free goods typically require that all passengers leaving the departures level of the international areas of the terminal either board an international flight or exit through the Immigration and Customs area. No return past security on the departures level is permitted.
- In the United States, gate delivery is the prevalent mode of operation for duty free concessionaires; however, cash and carry may be permitted with approval from local and district Customs officials in locations where the purchased goods are restricted to secure concourses with no domestic activity. Duty free concessionaires at San Francisco International Airport and Los Angeles International Airport are permitted to operate on a cash and carry basis at the discretion of Customs authorities when there are no domestic passengers present. Cash and carry is a win-win proposition for the customer (who has the peace of mind that he/she can take high-value purchases onboard the aircraft), for the concessionaire (which has additional time to make sales as well as reduced operating costs and higher sales); and for the airport operator (which achieves both improved revenues and improved customer service).
- Duty free is a draw for many international passengers. For passengers from countries other than the United States, duty free is often considered an opportunity to purchase highly taxed luxury items (cigarettes, liquor, jewelry, and fragrances), and these passengers are highly motivated to seek out duty free. This creates the opportunity to use duty free as the “anchor store” in a concession zone.
- Duty free is a mixture of luxury products (which are typically presented in a well-designed environment) and high-volume goods (which require a different environment). A “store in store” approach allows the store design and lighting to reflect the very different product lines offered. International terminals with high traffic levels and spend rates can support a variety of duty free items. It may be advantageous to separate the luxury goods (fragrances, luxury accessories, and jewelry) from liquor and tobacco.
- Where there is volume to support them, branded duty free boutiques can be provided separately from a duty free “general store.” As with boutiques on a luxury shopping street, duty free boutiques allow for a very high level of customer service consistent with the brand’s standards and customer expectations.

Foreign currency exchange booths are also common in international terminals. Depending on passenger traffic levels and the concentration of passenger flows, foreign currency exchange



booths may be located in pre-security departures areas, in post-security departures areas, and in arrivals areas outside of the Federal Inspection Facility (FIS) facility. Outside of the United States, currency exchange booths are often located within the Customs baggage claim area or inside the exits from the Customs area. These locations provide a quieter, more secure environment compared with the typical international arrivals area.

Certain services, such as secure baggage storage, are also more common in international terminals. Food and beverage, convenience retail, and specialty retail concessions in international terminals are planned similarly to the way they are planned in domestic terminals, although the spend rates in international terminals are likely to drive higher amounts of supportable space.

## 5.7 Wayfinding and Concession Signage

Effective concession signage and information programs can reduce confusion and increase sales. The objectives of concession signage are the following:

- Inform passengers pre-security of the concessions they will find post-security and the concession locations
- Communicate brands to passengers as they walk past or through concession areas
- Communicate product or service information for unbranded concession units
- Create an interest in shopping or dining at the concessions
- Avoid interfering with basic passenger information regarding gates, washrooms, etc.
- Add color and vibrancy to the terminal
- Inform arriving visitors of the concession opportunities they will find when they depart from the airport at the end of their trips

Various concession signage programs are used at airports today, ranging in effectiveness from very poor to excellent. Some constraints that contribute to poor programs include basic terminal designs that use soffits or store caps to house ductwork for ventilation and air handling, often reducing ceiling heights and the area available for concession signage; restrictive terminal architecture controls on signage locations, sizes, colors, etc.; and low ceilings in older concourses.

In new terminals or extensive modernizations, it may be possible to reduce or eliminate these limitations.

Modern, effective programs include blade signs, 3-D signs, and key signage (e.g., directories) to guide the customers. Blade signs are particularly effective in post-security areas. The passengers are moving quickly and seeking information on their departure gates. An effective blade sign presents nearly instantaneous information on brand and product. An example of blade signs is provided in Figure 5-13. 3-D signage is also very effective in communicating concession information. Importantly, it can also be used to add color and drama, improve visibility, and communicate that an area of the terminal functions as a commercial zone (see Figure 5-14). Concession directories are important at key decision locations such as pre-security to provide information on concessions both pre-security and post-security and immediately post-security, near the passenger security screening checkpoint, to provide information on locations, types, brands, etc., in each concourse or gate area. An example of a concession directory is shown in Figure 5-15.



## 5.8 Return on Airport Investments in Concession Space

Concession space typically yields airport revenues well in excess of the annualized capital and operating and maintenance (O&M) costs of the floor space; therefore, even if extra concession space is provided, the airport revenues would be expected to exceed the cost of providing the space.





**Figure 5-13. Example of blade sign (San Francisco International Airport, Terminal 2).**

Importantly, except at the productivity levels of nonhub airports, even the low end of typical productivity ranges typically provides a revenue stream to the airport enterprise that will exceed the costs of constructing and maintaining the floor space. Table 5-11 presents an example of a financial analysis showing the internal rates of return (IRRs) for analysis of various combinations of expected sales per square foot, percentage rent, capital costs for terminal space, and operating and maintenance expense. This type of analysis should be customized for the expected sales, costs, and rent structure of each airport. In this example, low productivity from food and beverage spaces and low percentage rent would produce low returns, with an exceptionally long payback period and a low IRR. Other concession categories achieve reasonable paybacks and internal rates of return. This suggests that there is an oversupply of food and beverage space that will not be profitable at an average productivity of \$500 per square foot.



Source: AirMall® USA.

**Figure 5-14. 3-D concession signage (Baltimore/Washington Thurgood Marshall International Airport).**



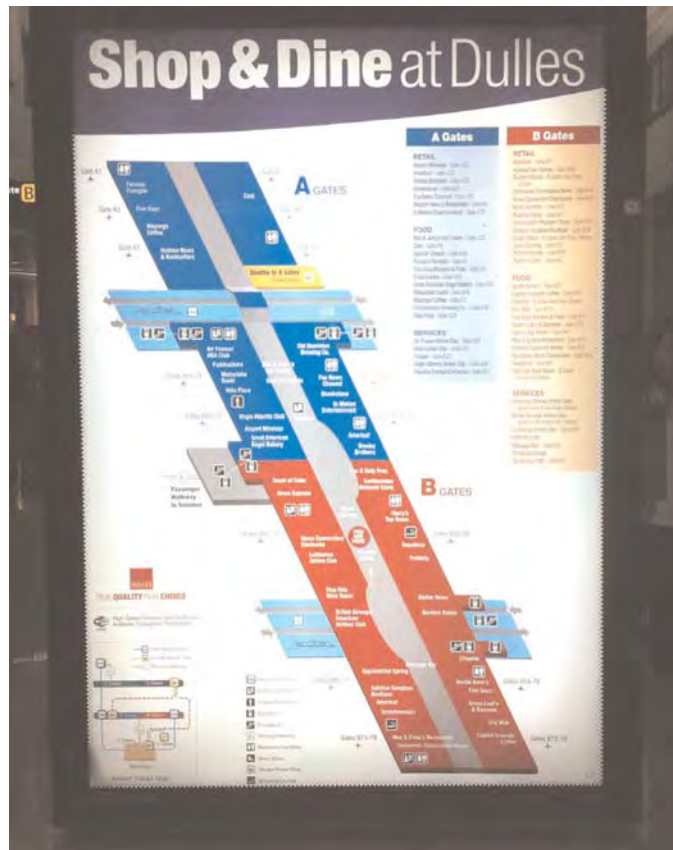

Figure 5-15. Concession directory (Washington Dulles International Airport).

Table 5-11. Internal rate of return for various combinations of productivity, rent percent, and terminal capital and operating and maintenance costs.

Category	Productivity (\$/SF)	Percentage Rent	Rent (\$/SF)	Annualized Capital & Operating Costs	Payback @ 5.5% Real Interest (Years)	IRR (real)
Food						
High	\$1,200	12%	\$144	\$85	8.0	14%
Low	\$500	9%	\$45	\$49	27.0	1%
Retail						
High	\$1,600	17%	\$272	\$85	3.5	32%
Low	\$900	10%	\$90	\$49	6.0	18%
Duty Free						
High	\$1,600	28%	\$448	\$85	1.9	55%
Low	\$900	15%	\$135	\$49	3.5	32%

IRR = Internal rate of return

SF = Square foot

Source: LeighFisher.

### 5.8.1 Impediments to Adding Concession Capacity

With a relatively high rate of return on investment in needed concession space, what prevents airport operators from expanding concessions? Impediments typically include the following:

- Older terminals with very limited post-security space
- Narrow concourses
- Long concession agreement terms
- Dry concourses, without the utilities to support kitchen operations
- Failure to make the business case for expansion to the users

Typically, concession space is expanded as part of a broader terminal expansion program designed to add overall terminal capacity, where the scale is sufficiently large so as to bring the unit square footage costs down to affordable levels.

### 5.8.2 Strategies for Space-Limited Terminals

There are alternatives for space-limited terminals that can improve the concession program, including retail merchandising units, wall hugger concession units, in-holdroom concessions, pop-outs between gates, relocation of other activities, and automated retail machines, all of which are discussed below.

#### *Retail Merchandising Units*



One approach to specialty retail units is the use of retail merchandising units (RMUs or kiosks), which are self-contained, relatively low-cost, and small footprint units that can be used to provide concessions in space-limited terminals, to add specialty concepts to serve lower traffic levels, or to add new concepts to an existing specialty program. These units range in size from 30 square feet to 100 square feet and can fit in locations unsuitable for larger units. The operators of some airports with wide concourses have installed RMUs down the center of the concourse.

#### *Wall Hugger Concession Units*



There is such demand for concession units to fit into very shallow spaces, particularly on concourses, that many news/gift, food, and specialty concessionaires have developed units specifically designed for very shallow spaces. These units often provide a wide frontage to present the product, but occupy a depth of less than 4 feet.

#### *In-Holdroom Concessions*



Small units can be installed directly into holdroom space, subject to airline approval. These units include coffee bars, fast food units, and bars (subject to state licensing regulations). The placement of concession units directly in holdrooms typically requires consideration of the effects on janitorial cycles and carpeting in the area.

#### *Exterior Pop-Outs between Gates*



As a general rule, the cost of creating or enlarging terminals for concessions alone is prohibitive. Adding space solely for concessions, say, by building space onto a concourse, is expensive because it requires two (or three) levels of building, and the construction must take place in the secure air operations area, where building is expensive. Seldom will the net concession revenues offset the full cost of constructing incremental concession space. There are examples, however, where a business case has been made that the return on investment is sufficient to justify the expenditure, and, if the terminal design is conducive to building out between gates, a business case should be analyzed if the need for additional concession space exists.

### *Relocation of Other Activities*

Departures level space, particularly post-security, is valuable space with many demands. It may be possible to increase concession space by relocating other activities, for instance:

- To provide additional post-security concession space, security at Chicago O'Hare International Airport's Terminal 5 is being modified and relocated under a long-term concession agreement.
- Airline lounges are low-rent space compared to concessions and often function more effectively on a mezzanine level. Relocating lounges off the departures level can free up space for concessions.
- There may be other functions not directly related to passenger services, such as station managers' offices or airline crew check-in lounges, on the departures level that can be relocated to other levels.



### *Automated Retail*

In recent years, the use of automated retail machines has increased. These machines combine mechanical vending with touch-screen technology that provides detailed customer information and transaction processing. These units require only 28 square feet and a standard 110 volt power outlet and can offer a range of convenience merchandise or a range of branded merchandise, such as cosmetics or electronics, as shown in Figure 5-16. With sharply reduced labor



Source: Zoom Systems, Inc.

**Figure 5-16.** *Branded automated retail.*

costs and secure inventory control, these machines can operate in lower-traffic areas, operate 24 hours per day, extend the range of merchandise offered, and provide incremental revenues without capital investment on the part of the airport operator. Machines can also be easily relocated, requiring shorter lease terms and no buyout requirement if the space is needed for other purposes.

While most often used for specialty retail, these machines can also fill other needs. For example, at San Francisco International Airport, these sophisticated vending machines have been installed outside of the international arrivals area, where they offer travel necessities and personal care items as a service to passengers arriving on late night and early morning flights.

# The Concession Mix

Developing the concession plan is a multistep process. Each step is necessary to maximize program impact and performance. Once the sales forecasts, the space productivity goals (sales per square foot) and the amount of commercially supportable space have been determined and the locations of the concession areas (space plan) have been determined, the specific uses of these concession areas must then be defined as accurately as possible. This chapter discusses the following:

- Achieving the right overall balance
- Program differentiation and creating a sense of place
- Concession theming
- Branded concessions
- The concession mix by category

## 6.1 Achieving the Right Overall Balance

In developing the concession program for a particular airport, all of the previously defined components of the concession plan must be taken into account, including the concession types best suited to the airport and the proposed configuration of the concession space, both pre-security (landside) and post-security (airside). The airport's passenger and customer profiles (see Chapter 4), as well as their preferences in terms of wants and needs, are major inputs to defining the concession mix.

Factors such as customer income; potential levels of service; local/regional flavor and theming; incorporation of local, regional, and national brands; and customer preferences may also be considered in the definition of concession concepts. An effective concession plan requires balancing a number of factors:

- The relative importance of the pre-security and post-security components of the concession program
- The relative importance of each concession category in the concession program
- The relative importance of concept types within the concession mix for each of the proposed concession categories
- The relative importance of branded versus generic concessions within the proposed mix
- The relative importance of national, regional, and local brands within the proposed mix
- The incorporation of recent trends in the concession program
- The judicious use of differentiating elements to create a sense of place
- The relative importance of revenue return and customer service

Table 6-1 shows an example of a food and beverage concession mix definition matrix recently used in preparing an airport concession plan at a medium hub airport. The same type of matrix is used for other concession categories.



**Table 6-1. Example concept evaluation matrix used to define a concession mix.**

Type of Service and Food	Revenue Potential	Level of Service	Local Appeal	Regional Appeal	National Appeal	Consumer Preference (from passenger surveys)
<b>TYPE OF SERVICE</b>		●●				
Fast Food/Food Court	\$\$\$	●●	●	●	●●	●●●
Cafeteria (self-service)	\$	●				●
Café (limited service restaurant)	\$\$\$	●●	●	●		●●
Casual Dining Restaurant	\$\$	●●●	●	●	●●	●●
Cocktail Lounge, Bar, Pub	\$\$\$	●●	●	●		●●
Specialty Food Kiosk or Cart	\$	●	●	●		●
<b>TYPE OF FOOD</b>						
Pizza	\$	●●				●●●
Juice/Fruit	\$	●●				●●●
Specialty Coffee/Tea	\$\$\$	●●	●●	●●	●●●	●●●
Salads	\$	●●				●●
Ice Cream/Frozen Yogurt	\$	●●				●●
Hamburgers	\$\$	●●			●●●	●●
Deli Sandwiches	\$	●●	●	●	●●●	●●
Chicken	\$\$	●●	●	●		●●
Health Food	\$	●●				●
Fish & Chips	\$	●●				●
Bakery	\$	●●	●●	●●		●
Italian	\$\$	●●				●
Steak/Ribs	\$\$	●●				●
Chinese	\$	●●	●●	●●		●
Soup	\$	●●	●	●		●
Seafood	\$\$	●●	●	●		●
Coffee/Donuts	\$\$	●			●●●	●
Pretzels/Popcorn	\$	●	●●	●●		●
Other Asian	\$	●	●●	●●		●

● Low \$  
 ●● Medium \$\$  
 ●●● High \$\$\$

Source: LeighFisher.

In this matrix, each potential concept is evaluated for each of the selection criteria shown across the top of the table's columns. The income potential for the airport and the customer preferences as derived from a customer intercept survey are the primary factors in concept selection. Other factors are usually secondary. As part of the assessment of the types of services being considered, local appeal, regional appeal, and national appeal are considered.

Table 6-2 depicts an example of customer market segment preferences for different types of food and beverage concepts and levels of service. Customer preference surveys are one of the tools most often used in selecting the appropriate airport concession concepts and mix.

The judicious use of these planning tools, along with the space-planning criteria described in Chapter 5, enable the concession manager to define a specific and optimal concession mix for the airport. Table 6-3 illustrates a hypothetical example of a concession mix developed for specific areas of an airport.

When developing the concession mix, the theoretical amount of supportable space must be adapted to the available concession space within the terminal. It is unusual for available concession space in all areas of the terminal to accommodate the full complement of commercially supportable space. Nevertheless, understanding the differences between supportable and available



**Table 6-2. Food and beverage service preferences of surveyed customer market segments.**

Type of product	Passengers (%)	Employees (%)	Well wishers and meeters/greeters (%)
<b>Types of food &amp; beverage services</b>			
Fast food/food court	23	23	40
Cocktail bar, lounge, pub	19	14	23
Full (table) service restaurant	18	14	32
Cafe (limited service restaurant)	12	16	28
Cafeteria (self service)	9	14	18
Specialty food served at kiosk or cart	4	9	8
<b>Types of food</b>			
Juice/fruit	45	28	41
Pizza	44	21	39
Coffee/donuts	44	16	57
Specialty coffee (espresso, cappuccino, etc.)	39	19	27
Salads	35	33	36
Health food	33	23	25
Hamburgers/hot dogs	32	14	28
Deli sandwiches	30	21	28
Italian food/pasta	30	9	14
Chinese	24	7	16
Seafood	21	12	14
Ice cream/frozen yogurt	20	26	27
Baked goods/pastry	18	19	26
Steak/chop house	15	12	19
Chicken	14	12	20
Soup	13	9	19
Fish and chips	10	5	10
Pretzels and popcorn	10	7	19

Source: From 2004 LeighFisher survey.

concession space allows for better decision-making and forces concession managers to evaluate tradeoffs in the use of space. For example, where space is limited, food and beverage concepts that allow faster throughput or that encourage sales of products that can be consumed in hold-rooms or aboard the aircraft can make limited space more efficient than, for example, a sitdown restaurant with lower seating densities and longer service times. Understanding the supply of space compared with the demand for space can help the concession planner determine more efficient uses of available space and offset some of the potential opportunity for loss of sales and revenue resulting from lack of capacity.

## 6.2 Program Differentiation and Creating a Sense of Place

In the not-so-distant past, and especially in the United States, airports have been criticized for looking alike. In fact, some brands were so ubiquitous that they became identified by consumers as being “airport brands.” More recently, regional and local brands have been added to airport concession programs, which can help concession managers create a sense of place and differentiate their programs from those at other airports.

Theming (i.e., incorporating local elements into the overall concession program design) can also create a sense of place that differentiates one airport from another. Whether a new terminal is being



**Table 6-3. Example concession mix.**

Unit Number	Zone	Area (sq ft)	Suggested concept	Comments/Potential Brands
F2	Arrivals - North	500	Specialty coffee	News/gift operated by specialist
C1	Arrivals - South	500	News kiosk	Convenience retail kiosk near exit from security
F1	Arrivals - South	500	Specialty coffee	Subway, Quizno's, Heidi's, Charley's, other
C2	Central Landside Area	1,750	Newsstand	News/gift operated by specialist
F3	Central Landside Area	850	Specialty coffee/bakery	Starbucks, Peet's, SBC, Caribou, local brand, other
F4	Central Landside Area	850	Deli	Subway, Quizno's,
S1	Central Landside Area	100	ATM	Local bank; location to be determined
S2	Central Landside Area	400	Currency exchange	Kiosk; specialist forex operator
C3	Central Airside Departures Core	1,600	News/books	News/books operated by specialist
D1	Central Airside Departures Core	1,500	Duty free	Full range of duty free merchandise
F5	Central Airside Departures Core	3,000	Casual dining with bar	Chili's, TGI Friday's, Harvey's (local),
F6	Central Airside Departures Core	650	Specialty coffee	Starbucks, Peet's, SBC, Caribou, local brand, other
R1	Central Airside Departures Core	800	Specialty retail	Travel accessories or gadgets
R2	Central Airside Departures Core	500	Jewelry	Jewelry kiosk
R3	Central Airside Departures Core	900	Specialty retail	Fashion, designer clothing
R4	Central Airside Departures Core	600	Specialty retail	Bluwire, InMotion, Airport Wireless
S3	Central Airside Departures Core	250	Shoeshine	Local
C4	Concourse A Departures	1,450	Newsstand	Newsstand operated by specialist
F10	Concourse A Departures	700	Specialty coffee	Specialty coffee or coffee bakery, donuts, bagels, other
F7	Concourse A Departures	3,950	Food court with seating	Three quick-serve concepts; Mexican, burgers, sandwich, pizza/pasta, other
F8	Concourse A Departures	1,500	Bar	Concourse bar with limited food menu
R3	Concourse A Departures	1,000	Spa	XpresSpa, Be Relax, d-parture, Absolute, others
S4	Concourse A Departures	100	ATM	Local bank; location to be determined
C5	Concourse B Departures	1,450	Newsstand	Full range of duty free merchandise
F12	Concourse B Departures	1,500	Bar	News/books operated by specialist
F11	Concourse B Departures	700	Specialty coffee	Specialty coffee or coffee bakery, donuts, bagels, other
F9	Concourse B Departures	3,950	Food court with seating	Three quick-serve concepts; deli sandwich, sushi, others
R7	Concourse B Departures	750	Specialty retail	Various; open to propose?
S5	Concourse B Departures	100	ATM	Local bank; location to be determined

designed or an existing building is being renovated, these issues are best resolved at the planning and design phases in partnership with the terminal architect or with a specialist retail architect. The concession program design may differ from the other architectural rendering of the terminal building. However, this differentiation must be compatible with the general terminal environment. Detailed concession design standards are an important tool in creating an overall concession theme that complements the terminal, captures a sense of the local community, and provides a common palette for the design of individual concession units in a way that is unique while consistent with the overall concession theme. Additional information on concession design and construction can be found in Chapter 12.

### 6.3 Concession Theming



Theming contributes to the differentiation of an airport's concession program and to a sense of place. Use of a theme can also contribute to differentiating the commercial areas of the terminal building from other public and airline areas. While allowing for some differentiation, the design of the commercial areas should be compatible with the general design of the terminal building.

Figure 6-1 shows how a theme has been used to create a very local/regional sense of place at Vancouver International Airport. Local materials, architectural styles, a color palette derived from the Pacific Northwest, and native cultural icons such as totems and lodges are used to create a strong



**Figure 6-1. Concession design (Vancouver International Airport).**

sense of place and a unique passenger experience. This sense of place is incorporated into the concession design.

Figure 6-2 shows how a theme has been used at an airport in Barbados to create a sense of place. Barbados is known for the chattel houses used by agricultural workers in the past. This theme has been used judiciously in the design of the concession space to create an environment that reflects both local design themes and the island's cultural history.

Chicago Midway International Airport also represents a good example of the use of material to create a sense of place, in this case an urban environment featuring traditional masonry and building canopies typical of the Windy City, as shown in Figure 6-3.

## 6.4 Branded Concessions

There is a consensus among the operators of airports that branding contributes significantly to the performance of a concession program. National brands are important for any airport, while



**Figure 6-2. Examples of concession program theming at a Caribbean airport.**



**Figure 6-3. Urban design for concessions (Chicago Midway International Airport).**

regional and local brands may be more important at airports with a larger domestic passenger base. A main issue is the definition of what is considered a local brand or a regional brand, which may be determined on an airport-by-airport basis.

The preferences of the airport's customers in terms of branding can also be determined through the survey process. Figure 6-4 illustrates the results of a passenger survey of types of food service brands. This bar chart illustrates that almost 50% of passengers prefer a food program that includes a good assortment of national and local brands. With respect to the airport employee market, 60% prefer a concession program with a national and local assortment of brands. Of meeters/greeters and well-wishers, 42% also prefer this type of program. Passenger interviews and focus groups have noted that brands represent known quantities and safe choices that reduce the risk of a bad experience and provide a product of known (although not necessarily high) quality.

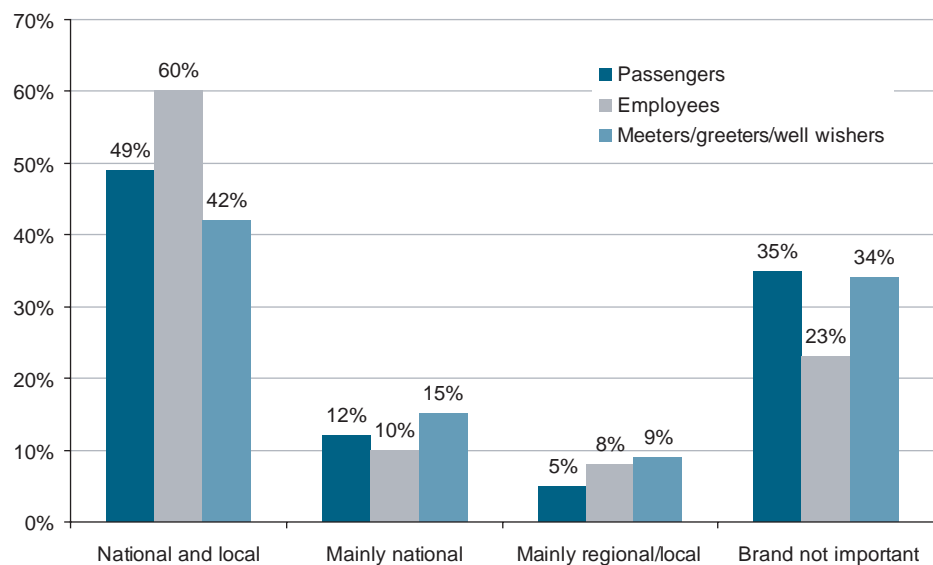

Source: From 2004 LeighFisher survey.

**Figure 6-4. Branding preferences in one airport survey.**

Local or regional brands are often added to create an atmosphere that reflects the airport locale, i.e., sense of place. National brands have flourished in airports because they generally provide familiarity and consistency in product to customers. International brands that are offered at some airports often provide an upscale image and more exclusive product offerings suited to airport customers.

## 6.5 Food and Beverage Concession Category

The food and beverage category of airport concessions includes restaurants and bars; quick-serve units, including fast food; specialty coffee; bar/lounges; and traditional snack bars. A concession plan may include some or all of the following food and beverage concepts:

- **Casual dining/table service restaurant with bar**, a full-service or modified table service (where food is ordered at a counter and then served to the customer at the table) restaurant offering hot meals and full bar service.
- **Quick-serve/fast food**, including fast food prepared in advance and/or food made to order, served over the counter, operated as a stand-alone unit or within a food court, and often with a grab-and-go component.
- **Cocktail lounge/bar**, primarily offering alcoholic and non-alcoholic beverages with a limited food menu.
- **Specialty coffee**, serving premium brewed coffee and espresso-based beverages, teas, juices, pastries, and prepackaged salads and sandwiches.
- **Café**, a limited-service restaurant offering light meals, coffee, and other alcoholic and non-alcoholic beverages covering all meal periods and parts of the day.
- **Specialty food/snacks**, served at a kiosk or cart and including pretzels, popcorn, candy intended for immediate consumption (as opposed to packaged gift candy), and similar snack offerings.
- **Cafeteria**, where food is offered through a serving line, selected by the customer, and taken to a cashier for payment. Cafeterias were once a staple of airport food and beverage programs, but have largely been replaced by more contemporary concepts.



Figure 6-5 illustrates the percentage of all hub airports included in the surveys conducted for this research where each type of food and beverage service is offered as part of the concession

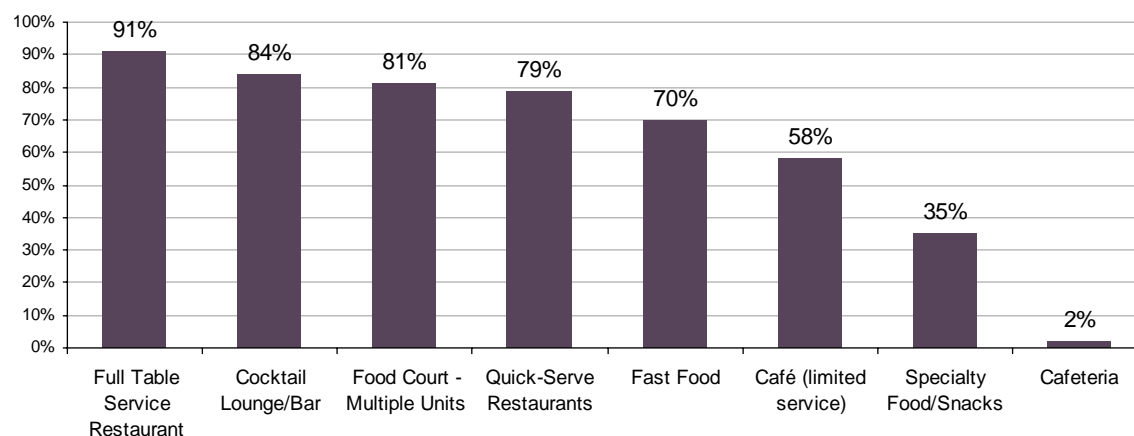

Source: LeighFisher using data from the airport surveys conducted for ACRP Project 01-11.

**Figure 6-5. Percentage of surveyed airports offering food and beverage service types.**



mix. Figure 6-6 illustrates the percentage of airports including specific food and beverage concepts in their concession programs.

In domestic terminals, food and beverage concessions are the strongest magnets drawing customers into a concession or retail zone. A clustering of various types of conveniently located retail shops and services near food service opportunities, especially post-security, as that is where most sales occur, can help optimize sales. The primary market for food service is enplaning passengers, with a secondary market consisting of their well-wishers and airport employees.



In many international terminals, food and beverage concessions are placed in corner locations to (1) preserve frontage for retail and (2) take advantage of the depth and width of corner locations. Food and beverage concessions then act as a draw to pull passengers in front of the retail offerings. Compared with domestic terminals, international terminals earn higher revenues on duty free and specialty retail sales, so preserving valuable frontage for retail is often a priority.

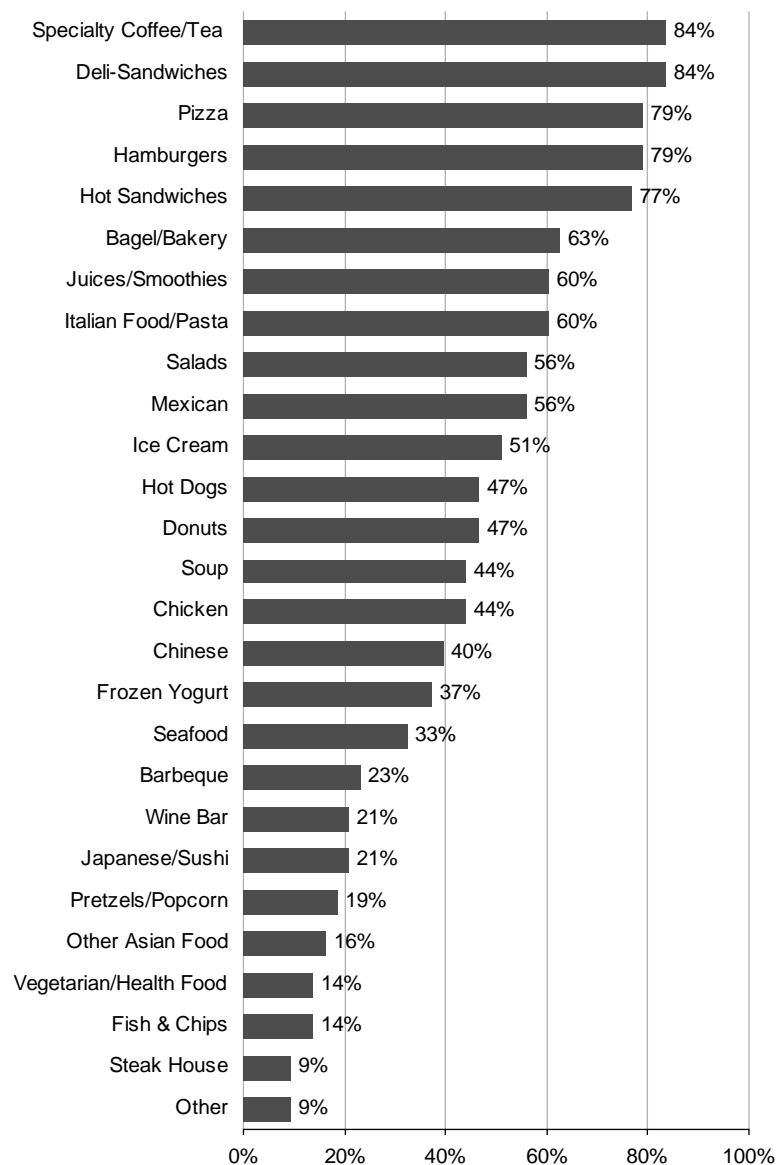

Source: LeighFisher using data from the airport surveys conducted for ACRP Project 01-11.

**Figure 6-6. Frequency of airport food and beverage concepts offered.**

## 6.6 Convenience Retail

The convenience retail concession category represents the traditional core of airport retail and includes various kinds of newsstands (news/gift shops, news/book shops, news/book/coffee shops, and convenience stores). This category consists of the merchandise most often sought by passengers. A newsstand will typically offer a selection of daily newspapers, magazines, paperback and hardback books, small travel accessories (such as sleep masks and luggage locks and tags), pre-packaged candies and snacks, bottled and canned drinks (at many airports), health and beauty aids, and various other sundries popular with travelers.

Variations on the pure newsstand are news/gift shops, news/book shops, and news/book/coffeeshops:

- **News/gift shops** have traditionally been the cornerstone concept in airport retail, particularly where space or passenger traffic is limited. News/gift shops consist of newsstands providing traditional newsstand items along with gift items and general merchandise. News/gift shops typically offer higher-margin merchandise to take advantage of the foot traffic generated by the news, magazines, and other newsstand items. Many larger airports have, in certain locations within the terminals, shifted from large news/gift shops to smaller newsstands, with the recovered space used to expand the specialty retail category.
- **News/book shops** devote the majority of their space to books, with some space devoted to traditional newsstand merchandise. News/book shops may, at times, also include a coffee element.
- **News/book/coffee shops** consist of a newsstand combined with a specialty coffee unit and may include a smaller airport version of major bookstores.
- **Convenience stores** offer a range of prepared or self-serve food and beverage items along with newspapers, magazines, books, candies, and various sundries. As with its off-airport counterpart, the airport convenience store is intended to be a one-stop shop for passengers with limited time or who value convenience, and add-on sales are encouraged across categories.

The convenience retail category implies quick service and must be readily available to the traveler, but need not be in prime space, as customers will seek them out. Figure 6-7 illustrates the percentage of airports included in the surveys conducted for this research that offer the different categories of convenience retail concessions described above.

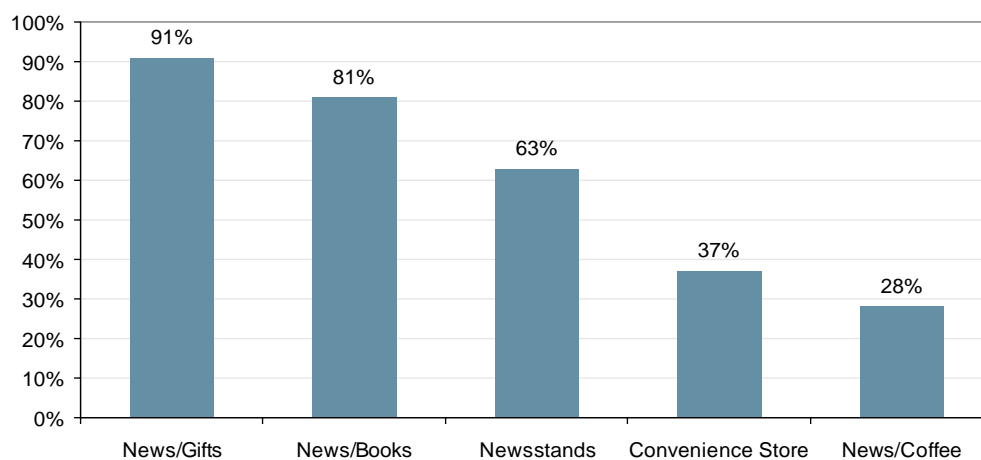

Source: LeighFisher using data from the airport surveys conducted for ACRP Project 01-11.

**Figure 6-7. Frequency of types of convenience retail services at surveyed airports.**



## 6.7 Specialty Retail

The specialty retail concession category includes shops specializing in such merchandise as books, bulk candy and fine chocolates, gourmet or packaged specialty foods, fashion accessories, flowers, arts and crafts, sporting goods, high technology personal electronics and mobile accessories, fine art, jewelry, gadgets, toys, clothing, and the like. Many specialty retail locations are branded and include mall retailers that have developed smaller, airport-specific concepts.



The specialty retail category generates impulse shopping. People who purchase items at these shops rarely plan to do so, but their interest is piqued when they see a store or an item, and they make a purchase as a result. Therefore, it is very important that these shops be placed along major passenger flow routes in prime locations. Additionally, synergy (the interplay among shops) is very important in this category, as interest in one specialty shop may cause browsing and purchasing in another. Similarly, synergy between food (often thought of as the “magnet concession”) and specialty retail locations is important. As a result, these concessions tend to be more successful when clustered with other specialty retail shops or near major attractions, such as duty free or food and beverage concessions, a major art/sculpture display, and the like.

Figure 6-8 illustrates the percentage of airports included in the surveys conducted for this research that offer various specialty retail concepts within their concession program.

## 6.8 Duty Free

Duty free retail is the strongest “magnet” concession in an international airport terminal. International passengers often seek out duty free shops at airports. This does not mean, however, that duty free shops should be located in out-of-the-way spaces. Rather, the drawing power of duty free should be used to anchor concession developments and enhance the synergy among concessions. By locating concessions in this manner, duty free customers will be exposed to other, non-duty free shopping opportunities (e.g., specialty retail) in the vicinity.

Duty free shops in the United States are generally operated in one of two ways: cash and carry or gate delivery. At a few U.S. airports (Los Angeles International Airport, San Francisco International Airport, and others), where there are no domestic passengers in the departures area, Customs authorities may permit conventional cash and carry shopping. The duty free concessionaire is subject to fines equivalent to as much as five times the value of the merchandise if duty free purchases are taken from the secure departures area to a place other than aboard a departing international flight.

Gate delivery is not as successful as cash and carry because of the perceived risk on the part of customers that the goods may not be delivered or that they will forget to claim the goods at the gate. A major duty free operator has estimated that gate-delivery requirements may reduce sales by as much as 20% to 25% compared with cash and carry. Outside of the United States, duty free shops typically operate like any other airport shop in dedicated departures areas, with the customer making a purchase on a cash and carry basis.

In recent years, U.S. Customs and Border Protection has accepted the presence of cash and carry duty free shops in the departure areas of flights bound for the United States at Canadian airports, where U.S. Customs and Border Protection and U.S. Citizenship and Immigration Service pre-clearance services are available. However, the shops have limits on the value of merchandise that can be purchased. Before entering U.S. inspection areas, passengers can typically access a duty free shop that offers a broad range of cash and carry duty free items subject to the typical import limits for arriving U.S. passengers.



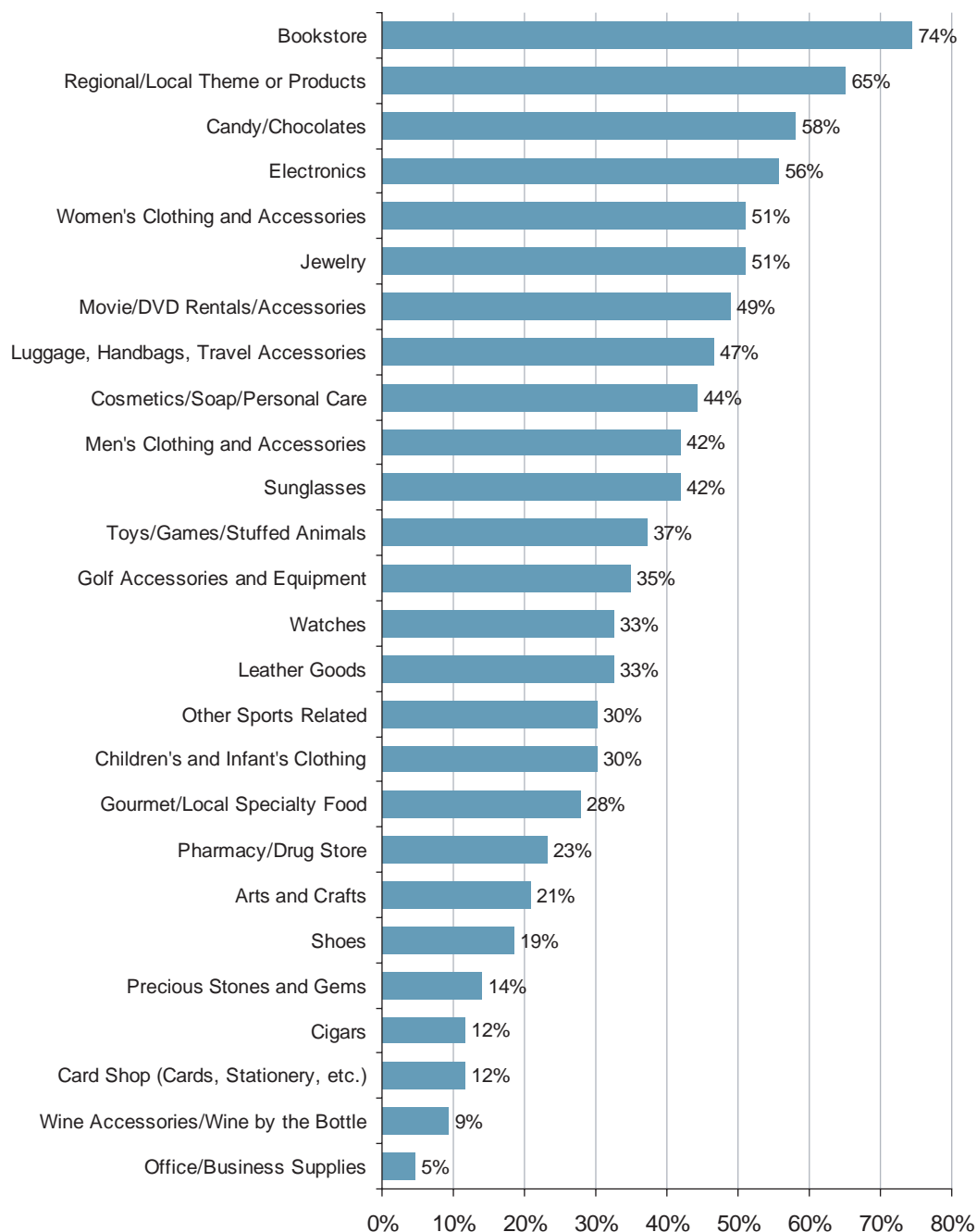

Source: LeighFisher using data from the airport surveys conducted for ACRP Project 01-11.

**Figure 6-8. Types of specialty retail concepts at surveyed airports.**

The duty free shops and related storage and warehouse facilities are considered a class of bonded warehouse, and their designs are subject to U.S. Customs and Border Protection approval. The Customs service delegates considerable authority to its regional and district directors, so variations exist in how local duty free shops are built and operated. However, they must meet the requirements for bonded warehouses in terms of the security of the merchandise to prevent it from entering the domestic economy. Otherwise, no specific design standards exist for duty free shops.

Outside the United States, many countries allow arrivals duty free shops to be offered at their airports. An arrivals duty free shop is usually located in the baggage retrieval area, close to the baggage carousels, but prior to Customs inspection. Where arrivals shops are located outside of the Customs inspection areas, they are often travel retail shops, not true duty free shops, and do not sell bonded merchandise on a true tax free or duty free basis.

The common types of duty free merchandise include liquors and other alcoholic products, fragrances and cosmetics, and cigarettes and other tobacco products. Customers achieve the greatest savings on these products because of their high price points and because they may be subject to heavy duties and taxes. Over the years, duty free concessionaires around the world have diversified into other luxury product lines such as confectionery, jewelry, watches, clothing, fashion accessories, leather bags, etc. These items may or may not be subject to high duties and taxes, but appeal to customers already open to making high-end retail purchases. (The incremental sales in this category can be significant and highly profitable for both concessionaires and airport operators. At the A. B. Won Pat International Airport serving the U.S. Territory of Guam, one Japanese vacationer made a single purchase totaling \$103,000 according to the duty free concessionaire.)

The relative share of total sales of each duty free product category varies greatly from one airport to another and is influenced by demographics of the passengers using the airport. In some countries, religious practices prohibit the sale of alcohol. Thus, the product mix to be offered in a duty free shop should be assessed and developed carefully, using market research tools, such as surveys, to determine the specific preferences of the airport market. The airport will want to have good information on which to base decisions regarding the allocation of scarce retail and duty free space. The detailed merchandise mix will be the responsibility of the concessionaire.

## 6.9 Services

This category of concessions includes various offerings that are provided to fulfill potential customer needs, largely as an aspect of customer service. Most of these concessions are not significant revenue generators for the airport on an individual basis.

The range of services offered will vary with passenger volumes and terminal configuration and may include the following:

- Arcades and game rooms
- Automated teller machines
- Baggage carts
- Baggage lockers
- Baggage wrap
- Banks
- Business centers
- Clinics/medical centers
- Currency exchange booths and machines
- Florists, flower carts, or flower vending
- Hair salon/barber shop
- Internet kiosks or chairs
- Massage
- Movie/DVD rentals
- Nail care
- Shoeshine
- Spas
- Public pay telephones
- Wi-Fi

Figure 6-9 illustrates the proportion of airports where each type of service is offered as part of their concession programs according to the surveys conducted for this research project.

A subcategory of the services category is specialty entertainment, which includes virtual reality simulators, mini-golf facilities, driving ranges, gaming machines, casinos, and the like. These concessions are relatively new, with few examples at airports. Specialty entertainment facilities

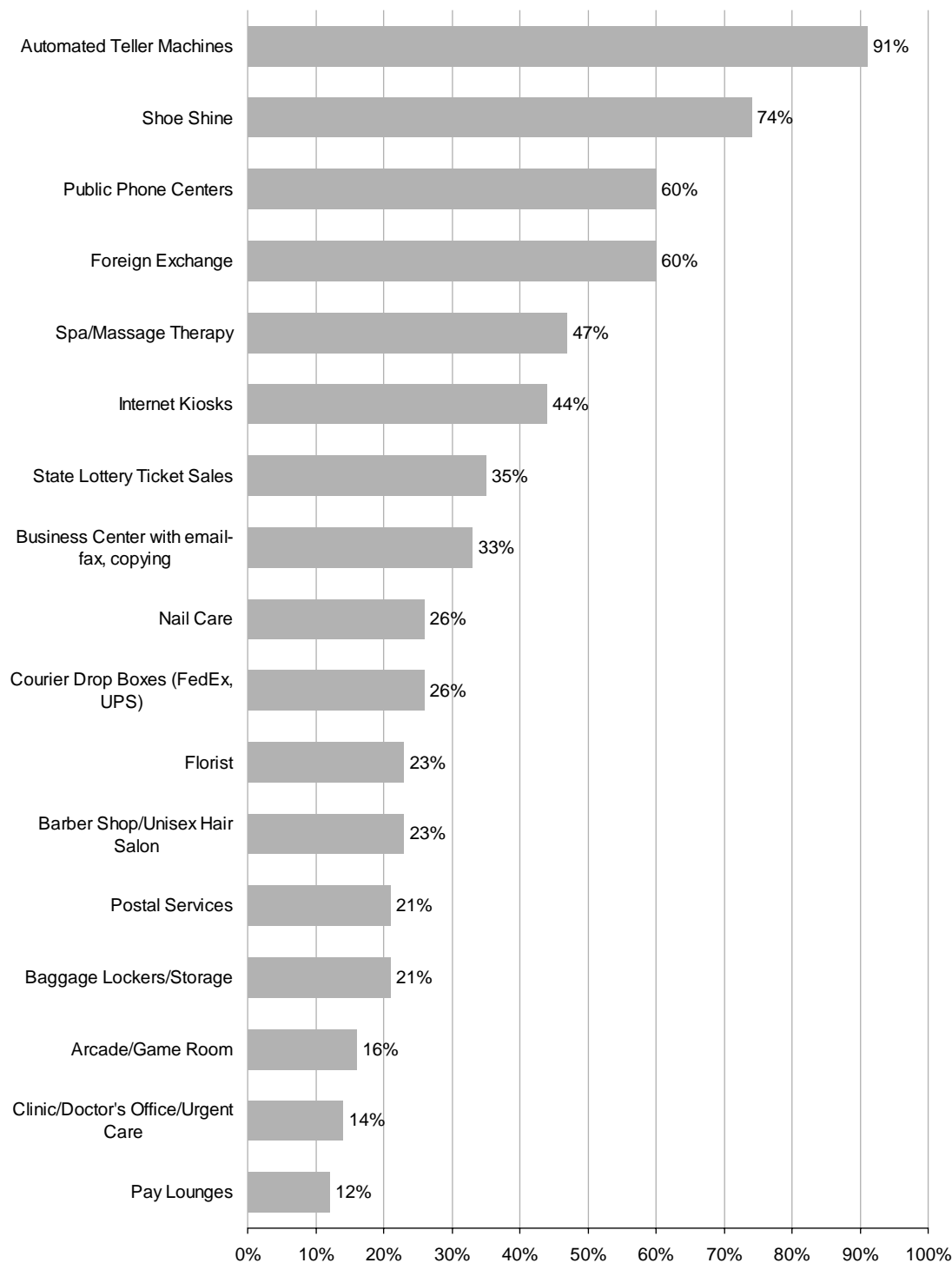

Source: LeighFisher using data from the airport surveys conducted for ACRP Project 01-11.

**Figure 6-9. Percentage of surveyed airports offering specific services.**

can often be located away from major passenger flows, as they are attractions that will draw people if properly promoted and advertised.

Services have been a growth area for airports in recent years as illustrated in Chapter 2. Airports have grown this category by adding new services and increasing the number of locations within the terminal where the service is offered.

## 6.10 Advertising

In-terminal advertising represents a great revenue potential for airports and should be part of any state-of-the-art concession plan. In recent years, significant developments have taken place in this category of concessions.

The advent of vinyl substrate banners and wall wraps is an innovation in airport advertising that has expanded options for airports, advertising concessionaires, and advertisers in recent years. It has changed the nature of traditional airport display advertising by making many surfaces—walls, loading bridge interiors, soffits, windows, and columns—effective for advertising displays.



On the other hand, the advent of plasma and other flat-panel digital screens has not revolutionized airport advertising in the way many thought it would. However, as the size of screens increases (one manufacturer currently offers a 103-inch model, but at a high price), the reliability of the technology improves, and costs continue to decrease, the use of flat-screen monitors for advertising will increase. The long-term potential is strong. Other types of dynamic displays, including customized LED displays, also offer the potential to create unusual, nonstandard advertising. Video projection systems are also occasionally used, but lack the brightness and overall visual impact of flat-panel displays.

As airport operators invest in high-technology information technology (IT)/communication networks, it makes sense to provide for advertising displays in these networks. Such networks have also recently been used to provide closed circuit and/or satellite real-time television programming to waiting passengers.

More recently, the advent of “intelligent portable devices” such as iPhones and BlackBerries, with high definition color screens, has created new opportunities for concessionaires, airport operators, airlines, and other potential advertisers to promote, in real time, their products and services to passengers and other airport users. For example, the operator of a duty free shop could advertise various promotions to passengers on their mobile devices as they circulate within the terminal toward their gates.

### 6.10.1 In-Terminal Advertising Program

A well-developed advertising program will ensure that all sites and media are fully integrated with the terminal architecture and environment, all sites are located for maximum effectiveness and sales, advertising does not conflict with wayfinding and other commercial signage, and the latest sign/telecommunications technologies are incorporated where appropriate.

An in-terminal advertising program should include the following elements:

- Identification of the optimum media range for the terminal and the markets specifically served by the airport
- Identification of the best locations for each type and size of advertising media



- Identification of the optimal number of advertising units for the terminal, by type
- Sites and networks to promote airport retail and other services to passengers
- Identification of the rules that the advertising provider(s) will need to follow in operating the advertising business at the airport
- Design guidelines for the key advertising units, including sizes and parameters to be respected by the designers.

In-terminal advertising includes static displays such as dioramas, baggage claim device wraps, baggage cart advertising, banners, wall wraps, product displays, concession advertising, digital screens, nontraditional advertising, sponsorships, and other creative advertising locations.

### *Dioramas*

Dioramas are back-lighted advertising displays using printed media. Single and double-sided dioramas are the most common type of advertising display. New lighting technologies, including LED light sources, lower the energy costs of this type of advertising and improve reliability and visibility. Large dioramas, often called “spectaculars,” are effective along corridor walls and in large public areas where sufficient wall area is available. Large displays have a strong visual impact and command premium rates. Figures 6-10 through 6-12 present examples of advertising dioramas.



### *Baggage Claim Device Wraps*

Some airport operators have successfully included advertising directly on their baggage claim carousels. These wraps are relatively effective as passengers often stand by the baggage carousels for long periods of time.

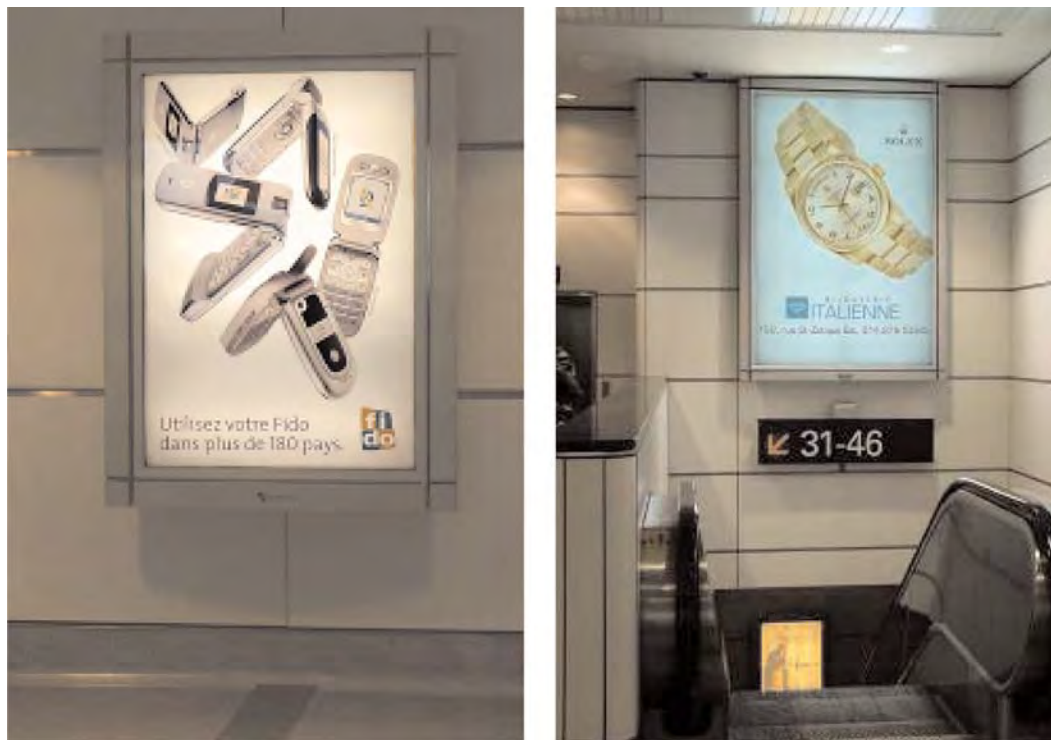

**Figure 6-10.** *Wall-mounted backlit advertising dioramas.*



**Figure 6-11.** Floor-mounted backlit advertising diorama.

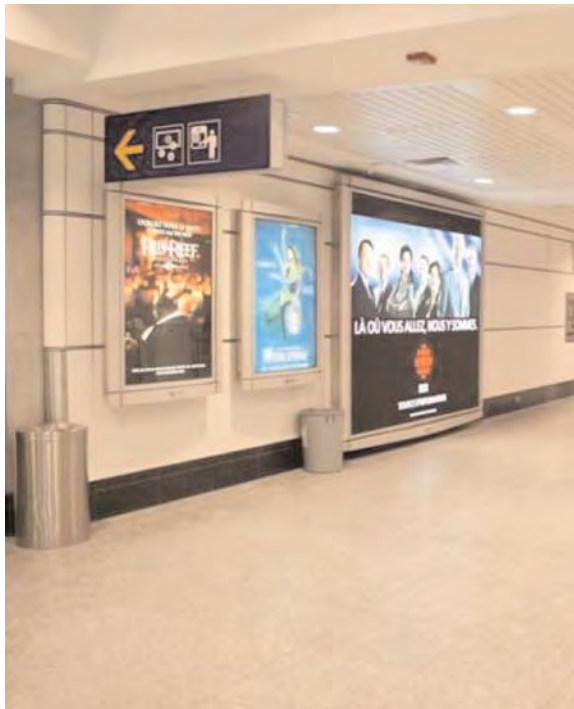

**Figure 6-12.** Large dioramas.



### ***Baggage Cart Advertising***

In the United States, baggage carts are most often provided on a pay-per-use basis through a concessionaire. Passengers pay a fee for each transaction using dollar bills, credit cards, or debit cards. International terminals are an exception, where airport operators often provide carts as a service to arriving international passengers, who tend to travel with more checked baggage. Outside the United States, most airport operators provide baggage carts as a free service and offset the capital and operating cost of the service by selling advertising on each cart. This could also be viewed as a form of sponsorship when a single advertiser places advertising on all of the baggage carts and where the advertising is long term (see Figure 6-13).



### ***Banners***

Banners can be very effective, particularly where sufficient vertical height is available in a terminal area. Banners are relatively easy and inexpensive to install and are especially useful for shorter term event campaigns and retail promotions. The capital investment requirement is very low, and their visibility is very good, especially when used in multiple locations within a given area (see Figure 6-14).



### ***Wall Wraps***

Wall wraps have become more prevalent in airport advertising in recent years because of their low cost and high degree of customization. The size of wall wraps invariably creates a high impact, and advertisers using them often consider themselves to be sponsors of an area of the terminal building. These wraps can be used to cover whole walls or used around columns.



Wall wraps are relatively easy to install and remove, as they do not require investment in supporting structures. Wall wraps can be highly effective, as shown in Figure 6-15, and can be



**Figure 6-13. Advertising on free baggage carts.**



**Figure 6-14. Advertising banner.**

particularly effective in creating a total “branding” experience, where a single advertiser is prominently displayed throughout an area of the terminal.

#### *Product Displays*



Exhibition areas, with or without staff, have enormous potential in many airports, particularly those with the target passenger profile for an advertiser.

Many advertisers seek opportunities to interact directly with potential customers to demonstrate their services or products and to establish a direct relationship. Staffed credit card sign-up booths are an example. Automobiles are another form of common product display, and automobile displays can command premium fees (see Figure 6-16).

#### *Concession Advertising*



Advertising, whether on backlit dioramas, vinyl substrate, or other media, may also be attractive to retail and food and beverage concessionaires in the terminal, depending upon the



**Figure 6-15. Wall wrap in a connecting corridor.**



**Figure 6-16. Automobile display.**

charges for their use. In international terminals, paid advertising for luxury brands is common and is intended to promote sales of the brand in the duty free shops or specialty shops and boutiques. Advertising outside of the shops is usually arranged through the airport advertising concessionaire.

Product advertising within retail stores, such as fashion or cosmetics ads within duty free shops, or prominently displayed rows of identical magazine covers in newsstands, is usually provided in consideration for display allowances, usually in the form of wholesale discounts from the manufacturer. Figure 6-17 shows a column wrap advertising a concessionaire's product offering.

### **Digital Screens**

The main advantage of using digital screens for advertising is the ability to change messages instantly and to show movement or animation. Digital screens can also be used to show closed circuit or broadcast television programming in areas where passengers are waiting for long periods.

Units combining plasma screen and LED technologies have been developed for airports and have been very successful in increasing the client base for advertising, as shown on Figure 6-18. These units are especially efficient when used by government agencies to disseminate information to passengers, as in the waiting areas before Immigration and Customs inspections. Tourism departments and agencies also find these units to be attractive for institutional advertising or tourism promotion.





**Figure 6-17. Column wrap advertising.**

### *Nontraditional Advertising*



Nontraditional advertising is increasing in airports that serve the passenger volumes capable of supporting these new media. Nontraditional advertising includes the following (although other terminal advertising locations can also be included):

- **Flight information displays.** Advertising is now being included on the flight information display system (FIDS) screens. FIDS screens can be a very effective advertising medium; however, an airport operator must be careful not to hide important flight information with advertising, as not being readily able to see such information could upset some passengers. It is much better to dedicate one of the screens to advertising than to incorporate advertising directly on the same screens as the flight information. Using screens not needed for flight information has limited



**Figure 6-18. Video screen in arrivals area with advertising.**



potential, as the screens are vacant only during off-peak periods, when fewer people are available to see the advertisements.

- **In-terminal radio station.** In-terminal closed circuit radio, broadcast over the terminal sound system, can feature paid advertising and promotion, music, or other local programming. This type of advertising is considered by many to be intrusive, however, and has had limited application at airports to date.
- **Exterior and interior loading bridge advertising.** Advertising on the interior and exterior of loading bridges can be profitable, especially if the exterior of the loading bridge is visible from the interior holdrooms of the terminal building. These are also frequently sold to a single advertiser as a form of large-scale sponsorship. Wall wraps on the interior loading bridges can offer targeted advertising. In determining revenue arrangements, ownership of the loading bridges may need to be considered if they are not owned by the airport operator. Interior loading bridge advertising is often bundled with exterior loading bridge advertising to create a strong advertising or sponsorship opportunity. International banks are particularly prominent buyers of this type of advertising (see Figure 6-19).

Figure 6-20 illustrates the proportion of airports that have included each type of nontraditional advertising in their concession programs according to the survey.

### Sponsorships

Many airport operators have the potential to create sponsorship agreements. Depending on the local market, some companies are willing to pay to brand an area or facility within the terminal with their corporate name.

Boston Logan and Chicago O'Hare International Airports have popular children's play areas sponsored by local children's museums. The operator of Bob Hope Airport in Burbank, California, worked with a local television station to create a branded seating area within the terminal featuring televisions and wall wraps. The Dallas/Fort Worth International Airport Board has entered into an exclusive contract with a soft drink bottling company that includes sponsorship payments, vending rights, and development of children's play areas at the Dallas airport. All concessionaires serving soft drinks at the airport are required to offer the brands of the official sponsor. Las Vegas McCarran International Airport has clocks throughout the



**Figure 6-19.** Advertising on loading bridge exteriors.

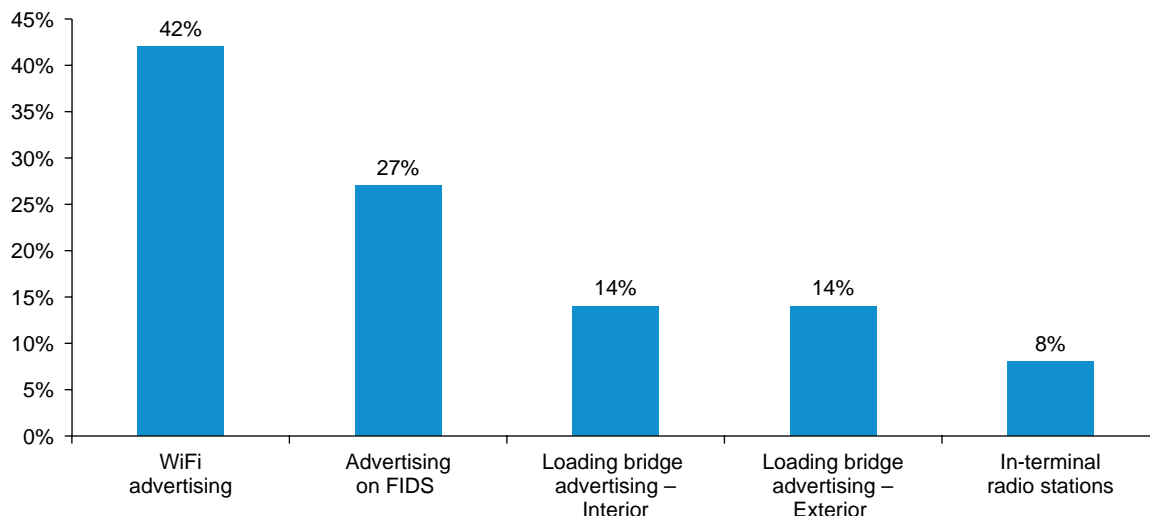

**Figure 6-20.** Percentage of airports surveyed using nontraditional types of advertising media.

terminal sponsored by Rolex, while the operator of Miami International Airport has entered into a similar arrangement with the Dominican Republic tourism board. Samsung sponsors popular charging stations for laptops and cell phones at a number of airports, typically located in or adjacent to holdrooms.

Other sponsorship opportunities may include business centers, smoking lounges, and common-use airline clubs, as well as United Service Organizations (USO) facilities. Figure 6-21 illustrates the percentages of airports with sponsored services in terminal buildings, according to the survey.

### *Other Creative Advertising Locations*



Restroom advertising has limited potential. However, for certain types of personal care products, this type of location may be attractive (see Figure 6-22). Although limited in scale, this type of advertising represents added value as it does not compete with sales from other types of advertising.

### **6.10.2 Best Locations for Each Media Type**



In choosing media types for each location, several factors should be considered, the most important of which is the number of passengers that will be exposed to an advertising display. Other factors should also be taken into account:

- Cost-effectiveness should be considered in the choice of media types and sizes for each location. Investment in backlit wall dioramas may require several years of use to achieve payback. Dynamic media, such as flat-panel monitors, are particularly capital intensive. Currently, only locations with direct exposure to high passenger volumes can justify heavy capital investment. In general, more conventional state-of-the-art, high-quality static advertising units should be located in areas where people are in motion, and the latest high-technology plasma screens should be located in areas where people remain for longer periods of time, such as the waiting areas around the baggage claim units, inside the departure holdrooms, or in front of food and beverage seating areas.



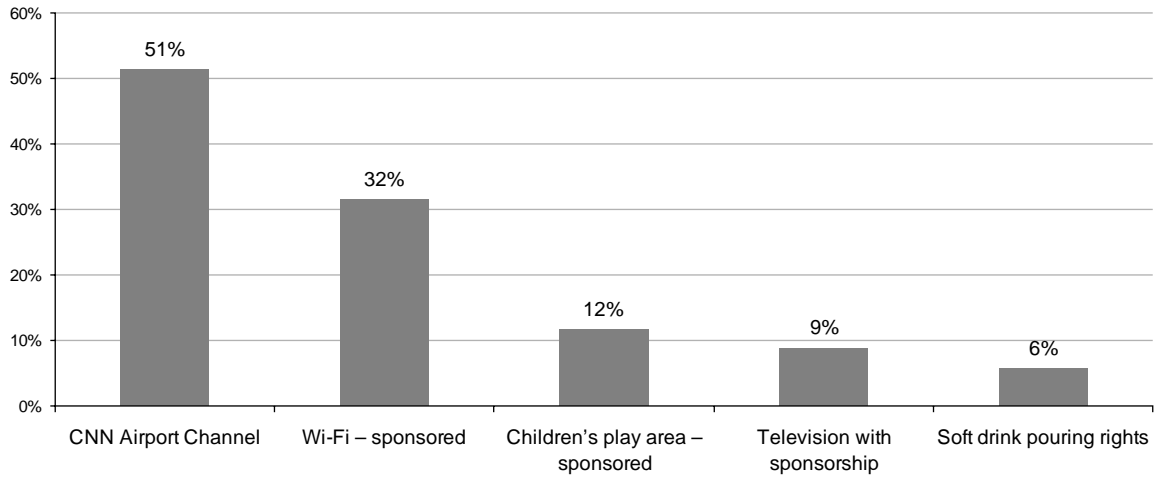

Source: LeighFisher using data from the airport surveys conducted for ACRP Project 01-11.

**Figure 6-21. Percentages of airports surveyed that have advertising sponsorships.**

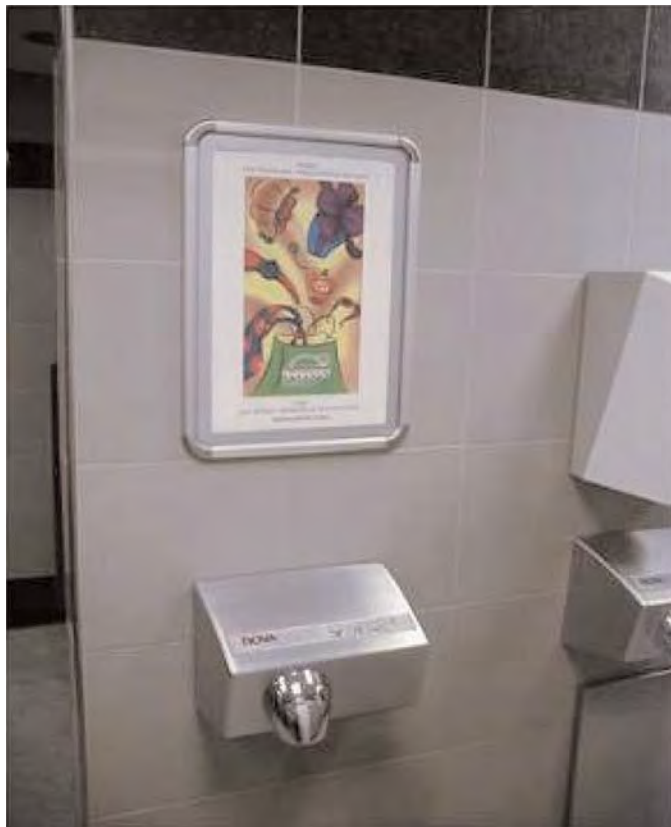

**Figure 6-22. Advertising in restrooms.**

**Table 6-4. Partial summary table: contents of an advertising master plan.**

Letter Code on the Drawing (location)	Type of Advertising Unit	Size	Recommended Locations in Terminal	Specific Locations in This Terminal	Total Proposed Number of Units (Advertising Faces)
A	Backlit column format (single or double sided)	55 inches high by 37 inches wide	In locations where people are on the move and not stationary	Double-sided, in the circulation areas of the plaza between the octagons and in the bus stations	34 (68)
B	Backlit horizontal (single or double sided)	40 inches high by 50 inches wide	In locations where people are on the move and not stationary	Double-sided, in the circulation areas of the plaza, facing the restaurant areas	18 (36)
C	Indoors spectacular backlit	8 feet high by 10 feet wide	In locations where people are on the move and not stationary	On the washroom walls, facing the main bus parking	35
D	Wall wraps	Various sizes (very adaptable)	Inside circulation corridors; around building columns; on jet bridges	Proposed to identify the sponsored zones. To be used around each main terminal column in the specific sponsored zone, which are contiguous to the circulation corridors with octagons, and the circulation corridor where the main food and concession area is located	42
E	Exhibition areas	Various areas for various products, with sales personnel	In wide circulation areas where people have time to browse	In the large area between the main plaza food and concession area and the central check-in area	1

Source: LeighFisher.

- Double-sided display units should be used when space is available for freestanding units, and single-sided display units should be used when they would be located on a wall. Sizes will vary depending on space availability and passenger volumes.
- Banners can be used with dramatic effect where sufficient ceiling height exists.

Table 6-4 illustrates a partial summary table of the contents of an advertising master plan prepared for an airport. This table depicts the types, sizes, recommended locations, and number of advertising units. Such a table would be complemented by a terminal layout drawing identifying each advertising unit at the right location with a code letter (see the left-hand column of the table).

### 6.10.3 Getting Information to the Customer



Helping customers understand the range of concessions and services within the terminal and their locations relative to the customer is an important element of good customer service and improves overall concession penetration, sales, and revenues. This can be accomplished by placing terminal concession directories strategically throughout the terminal (see the discussion of wayfinding in Chapter 5). For instance, making passengers aware of the pre- and post-security choices enables passengers to allocate their time more efficiently. Passengers with long dwell times or departure delays can use these directories to find offerings that fit their current taste or mood.

The concession developer at Pittsburgh International Airport uses displays to communicate its terminal-wide street pricing policy, which encourages concession patronage. The street pricing policy is displayed both in and around the concessions.

Information can also be sent to customers through different media, including terminal advertising (especially on digital screens), boarding pass jackets, coupons and leaflets, wayfinding panels, and the like. More recently, software has been developed to inform passengers of concession promotions, and they can even check menus and place their orders on their portable electronic devices and smart phones. This information dissemination technology is still developing, building upon the geographic information system (GPS) and location mapping software increasingly available in smart phones.



## CHAPTER 7

# The ACDBE Program

This chapter presents an overview of the U.S. Department of Transportation (U.S. DOT) Airport Concession Disadvantaged Business Enterprise (ACDBE) Program and how an airport operator's policies and plans for ACDBE participation can be successfully incorporated into its concession program. The discussion of the ACDBE Program includes the following topics:

- Federal requirements
- Determining concessionaire market area(s)
- Determining availability of ready, willing, and able participants
- Establishing race-neutral and race-conscious participation goals
- Outreach activities
- Methods for achieving ACDBE participation through contractual arrangements
- Evaluating joint venture and subtenant agreements
- Compliance monitoring and enforcement
- Attributes of successful ACDBE programs
- Measuring performance
- Reporting achievements
- Historical development and business trends
- Barriers to ACDBE participation
- Program audits
- Mentoring

In this chapter, references to the appropriate section under Title 49 of the Code of Federal Regulations (CFR) or other legal authority are included so that the reader may easily find additional information or clarification.

### 7.1 Federal Requirements



The ACDBE Program regulations are set forth in 49 CFR Part 23. These regulations are mandated by 49 United States Code (U.S.C.) 47107(e), enacted in 1987 and amended in 1992, and they incorporate certain provisions of the U.S. DOT Disadvantaged Business Enterprise (DBE) Program regulations (49 CFR Part 26). The purpose of 49 CFR Part 23 is to prevent discrimination on the basis of race, color, national origin, or sex in connection with the award or performance of any “concession agreement, management contract, or subcontract, purchase or lease agreement, or other agreement covered by [49 CFR Part 23]” (49 CFR Part 23, §23.9 [2005]).

49 CFR Part 23 applies to the operators of airports that have received a federal grant for airport development any time after January 1988 that was authorized under Title 49 of the United States Code. Recipients of these federal funds have agreed to grant assurances that require them

to administer an ACDBE program in compliance with 49 CFR Part 23 and all other applicable federal laws, regulations, executive orders, policies, guidelines, and requirements as they relate to the acceptance and use of federal funds (49 CFR Part 23, §23.5).

**References: 49 CFR Part 23, Section 23.5 and FAA Airport Sponsor Assurances, 3/2011**

The ACDBE Program regulations require the operators of primary airports to develop and implement an FAA-approved ACDBE program participation plan with the following objectives: (1) ensure nondiscrimination in the award and administration of concession opportunities, (2) create a level playing field to enable ACDBEs to compete fairly for concession opportunities, (3) ensure that their ACDBE program is narrowly tailored in accordance with applicable laws, (4) ensure that only firms that fully meet 49 CFR Part 23 eligibility standards are permitted to participate as ACDBEs, and (5) help remove barriers to ACDBE participation in concessions. 49 CFR Part 23 also provides airport operators flexibility in establishing and providing opportunities for ACDBEs. 49 CFR Part 23 defines a primary airport as a commercial airport that the Secretary of Transportation or his/her designee determines to have more than 10,000 enplaned passengers annually (49 CFR Part 23, §23.1).

Verbatim assurances set forth in 49 CFR Part 23, §23.9, must be included in all concession agreements (including management contracts subject to 49 CFR Part 23 requirements) executed with any firm after April 21, 2005, as follows (49 CFR Part 23, §23.9):

This agreement is subject to the requirements of the U.S. Department of Transportation's regulations, 49 CFR Part 23. The concessionaire or contractor agrees that it will not discriminate against any business owner because of the owner's race, color, national origin, or sex in connection with the award or performance of any concession agreement, management contract, or subcontract, purchase or lease agreement, or other agreement covered by 49 CFR Part 23.

The concessionaire or contractor agrees to include the above statements in any subsequent concession agreement or contract covered by 49 CFR Part 23, that it enters and cause those businesses to similarly include the statements in further agreements.

If an airport operator fails to comply with any requirement of 49 CFR Part 23, it may be subject to formal enforcement action under 49 CFR Part 26, §26.103, or 49 CFR 26, §26.105, or to appropriate program sanctions, such as the suspension or termination of federal funds or refusal to approve projects, grants, or contracts until deficiencies are remedied. Program sanctions may include actions consistent with 49 U.S.C. 47106(d), 47111(d), and 47122 (49 CFR Part 23, §23.101).

An airport operator's ACDBE program must incorporate the procedures and standards of 49 CFR Part 26, §§26.61–26.91 for certification of ACDBE participants in its concessions program. The program must also provide that certification decisions for ACDBEs will be made by the Unified Certification Program (UCP) in the state where the airport is located. UCP entities may be airports, state departments of transportation, and/or other entities acceptable to the recipients of federal funds, subject to approval by the Secretary of Transportation (49 CFR Part 23, §23.31; 49 CFR Part 26, §26.81).

Applicants for ACDBE certification must meet eligibility requirements. To participate as an ACDBE in an airport concession, a business owner must demonstrate social and economic disadvantage. The business owner must also apply to and receive ACDBE certification from a state's UCP.

To be eligible, an owner's personal net worth cannot exceed the dollar amount established in 49 CFR Part 23, §23.35, excluding the individual's ownership interest in an ACDBE or a firm that

is applying for ACDBE certification, the individual's equity in his or her primary place of residence, and other assets that the individual can document are necessary to obtain financing or a franchise agreement for the initiation or expansion of his or her ACDBE (or have, in fact, been encumbered to support existing financing for the individual's ACDBE), to a maximum of \$3 million. An individual's personal net worth includes only his or her own share of assets held jointly or as community property with the individual's spouse. A copy of the Uniform Certification Application can be downloaded from the DOT website at: [http://www.osdbu.dot.gov/Documents/pdf/dbe/Final%20Application\\_9-30-09.pdf](http://www.osdbu.dot.gov/Documents/pdf/dbe/Final%20Application_9-30-09.pdf) (49 CFR Part 23, Subpart C).

**References: 49 CFR Part 23, Subpart C and U.S. DOT Office of Small and Disadvantaged Business Utilization n.d.**

In addition, the gross receipts of the owner's business, averaged over the firm's previous 3 fiscal years, currently cannot exceed \$52.47 million. Standards for numbers of employees apply to certain in-terminal concessionaires, such as pay telephone providers, for which a standard of 1,500 employees applies. Concession size standards are the following (49 CFR Part 23, §23.33):

- A small business eligible for ACDBE certification—gross receipts, averaged over the firm's previous 3 fiscal years, not to exceed \$52.47 million
- Banks and financial institutions—\$1 billion in assets
- Rental car companies—\$69.97 million average annual gross receipts over the company's 3 previous fiscal years, as adjusted for inflation by the U.S. DOT every 2 years from April 3, 2009
- Pay telephone providers—1,500 employees
- Automobile dealers—350 employees

A concession business is eligible for ACDBE certification if it is a for-profit, small business at least 51% owned by one or more individuals who are all socially and economically disadvantaged or a corporation in which 51% of the stock is owned by one or more such individuals. The management and daily operations of the business must also be controlled by one or more of its socially and economically disadvantaged owners (49 CFR Part 23, §23.3).

Concessionaires and airport operators must make good faith efforts to achieve ACDBE participation. Good faith efforts are defined as efforts to achieve an ACDBE goal or other requirement of 49 CFR Part 23 that, by their scope, intensity, and appropriateness to the objective, can reasonably be expected to result in achievement of the ACDBE Program requirement. Good faith efforts are the following (49 CFR Part 26.53[f][2]; 49 CFR Part 23, §23.3):



- Exploring all available options to meet an airport's ACDBE goals, to the maximum extent practicable, through direct ownership arrangements with ACDBEs.
- Soliciting, through all reasonable and available means, the interest of all certified ACDBEs who have the capability to perform the work of the contract.
- Soliciting, through all reasonable and available means, the interest of potential ACDBEs that have been granted DBE status with a state's Unified Certification Program but are not currently engaged in airport concession activities.
- Effectively using the services of available minority/women community organizations; minority/women contractors' groups; local, state, and federal minority/women business assistance offices; and other organizations as allowed on a case-by-case basis to provide assistance in the recruitment and placement of ACDBEs.
- Attending pre-proposal and/or networking meetings related to concession contract opportunities.
- Documenting proof of any advertisements in general circulation, trade association, and minority- or woman-focused media.
- Documenting the follow-up to the initial solicitation with ACDBE.



- Selecting portions of the work to be performed by ACDBEs in order to increase the likelihood that the ACDBE goals will be achieved. This includes, where appropriate, breaking out contract work items into economically feasible units to facilitate ACDBE participation, even when a prime concessionaire might otherwise prefer to perform these work items with its own forces.
- Documenting how direct contracting portions of the concession contract or partnering or joint venture opportunities were selected to solicit ACDBE participation and how the selection was made in order to increase the likelihood of meeting an airport's ACDBE goals.
- Providing information to ACDBEs to solicit their bids in a timely manner, such as adequate information about the concession concept, space allocation being considered for ACDBE agreements, and general requirements of the contract to enable the ACDBE to supply a complete and competitive bid.
- Negotiating in good faith with interested ACDBEs. Evidence of such negotiation includes the names, addresses, and telephone numbers of ACDBEs that were considered; a description of the information provided regarding the plans and specifications for the work selected for ACDBE participation; and evidence as to why additional agreements could not be reached for ACDBEs to perform the work.
- Making efforts to assist interested ACDBEs in obtaining necessary equipment, supplies, materials, or related assistance or services.
- Making efforts to assist ACDBEs in obtaining independent lines of credit, financing, bonding, or other assistance that would make them a viable candidate for participation in a concession opportunity.
- Not rejecting ACDBEs as being unqualified without sound reasons based on a thorough investigation of their capabilities.
- Replacing an ACDBE that is terminated or has otherwise failed to complete its concession agreement, lease, or subcontract with another certified ACDBE.

## 7.2 Determining Concessionaire Market Area(s)

One element of the ACDBE goal setting process is determining the geographic area where all ready, willing, and able businesses seeking an airport's concession privileges and receiving most of the airport's concession revenue are located. 49 CFR Part 23 §23.45 defines the concession market area as

. . . the geographical area in which the substantial majority of firms which seek to do concessions business with the airport are located and the geographical area in which the firms which receive the substantial majority of concessions-related revenues are located.

Market areas may be different for different types of concessions, as illustrated in Table 7-1.

## 7.3 Determining Availability of Ready, Willing, and Able Participants

Establishing and maintaining records of companies interested and/or participating in concession opportunities at the airport is necessary in order to identify ready, willing, and able participants in the jurisdiction's market area(s). These records are often created from pre-proposal meeting attendance lists, public inquiries, outreach attendee lists, utilization reports, active participants' lists (i.e., current concessionaires), and the annual ACDBE participation achievement reports to the FAA.

A list of former concessionaires and unsuccessful proposers for concession opportunities will also be useful in determining availability, as well as information from other airports on compa-

**Table 7-1. Potential geographic market areas for in-terminal concessions.\***

Concession	Local	Regional	National
Food and beverage	X	X	X
News and gifts			X
Specialty retail	X	X	
Duty free			X
Advertising			X
ATMs	X		
Foreign exchange			X
Hair salon/barber shop	X		
Shoe shine	X	X	
Nail care	X		
Spa/massage	X		X
Business centers	X		
Baggage carts/lockers			X
*Representative list			

Source: ExStare Federal Services LLC based on studies done for several airports.

nies seeking or participating in their concession opportunities. At a minimum, the following information should be collected, maintained, and kept current for use when determining availability of ready, willing, and able participants:

- Company name
- Owner(s) name
- Owner(s) gender and ethnicity
- Complete address of the company's principal place of business
- Company telephone and facsimile numbers
- Owner(s) email address
- Type of concession the company is interested in
- Date of inquiry

## 7.4 Establishing Race-Neutral and Race-Conscious Participation Goals

The U.S. DOT allows airport operators to use several methodologies to determine 3-year ACDBE participation goals, including, but not limited to, data from disparity studies, active participants' lists, and U.S. Department of Commerce Census Bureau data. An airport's ACDBE Program must include a goal aimed at achieving the nondiscrimination objectives of 49 CFR Part 23. Airport operators must project the portions of their overall ACDBE participation goal that they propose to meet by using race-neutral and/or race-conscious measures. The use of numerical goals is the primary race-conscious measure for achieving ACDBE participation. Others include any measure the airport operator implements solely for ACDBEs, such as a bid conference or training where other businesses are not invited, and awarding additional points during the evaluation process for a firm's good faith efforts to utilize ACDBEs.



ACDBE participation needed to meet overall goals must be achieved as much as possible through the use of race-neutral measures, which include, but are not limited to, the following:

- Carrying out information and communications programs on contracting procedures and specific contract opportunities (e.g., ensuring the inclusion of DBEs and other small businesses on recipient mailing lists for bidders, ensuring the dissemination of lists of potential subcontractors to bidders on prime contracts, and provision of information in languages other than English, where appropriate)
- Unbundling large contracts to make them more accessible to disadvantaged and other small businesses.
- Arranging solicitations in ways to facilitate disadvantaged business and other small business participation
- Providing assistance to help disadvantaged businesses and other small businesses to obtain bonding and financing
- Providing technical assistance to all small businesses
- Implementing a supportive services program to develop and improve immediate and long-term business management, record keeping, and financial and accounting capability for DBEs and other small businesses
- Providing services to help ACDBEs and other small businesses improve long-term development, increase opportunities to participate in a variety of types of work, handle increasingly significant projects, and achieve eventual self-sufficiency
- Ensuring distribution of your DBE directory, through print and electronic means, to all small businesses and the widest feasible universe of potential prime contractors
- Assisting DBEs and other small businesses in developing their capability to use emerging technology and conduct business through electronic media

Airport operators must consult with stakeholders before submitting their overall goals to the FAA. Stakeholders include, but are not limited to, minority and women's business groups; community organizations; trade associations representing concessionaires currently located at the airport, as well as existing concessionaires themselves; and other officials or organizations that could be expected to have information concerning the availability of disadvantaged businesses, the effects of discrimination on opportunities for ACDBEs, and the recipients' efforts to increase participation of ACDBEs.

## 7.5 Outreach Activities

Outreach is one of the primary tools for identifying ACDBEs; communicating the availability of airport concession opportunities; and gathering information to assist the airport operator in developing and refining policies, procedures, and practices so that they reflect the airport operator's business objectives and the legitimate interests and concerns of prospective airport concessionaires.

One of the questions most often asked by airport staff when seeking small, disadvantaged, minority-owned, and woman-owned businesses to invite to outreach meetings is "how do I find them?" If the DBE liaison officer is not keeping a directory of interested ACDBEs, he/she should begin one immediately.

Keeping a list of all businesses that reach out to the airport operator to inquire about concession opportunities and that the airport operator's staff responsible for the concessions program and ACDBE program identify through outreach activities is very important for identifying interested firms, where they are located, and the types of goods and services they offer. At a minimum, the name of the business, the name of the owner of the business, the full address and telephone number of the business, and an owner's email address should be obtained. Keeping track of the date(s)



of an interested business's inquiry and the type of opportunity being sought is also useful in an airport operator's efforts to identify interested parties for specific types of concession opportunities. In addition to maintaining and updating a list of companies that inquire about business opportunities at the airport, numerous other sources are available for identifying businesses to invite to outreach activities, including disparity studies and availability studies.



Businesses that are listed in certification directories, those that have sought assistance through local economic development agencies, those that have proposed on previous concession opportunities, and those that have attended preproposal meetings are also prospects to be added to the list of contacts for outreach activities. Other sources of business prospects include concession operators at sports arenas, convention centers, malls, and similar locations.



Community-based organizations, chambers of commerce, and other organizations representing small, minority-owned, and woman-owned businesses are good points of contact for getting the word out. Other ways of reaching out are through advertising in general and business publications, local press, ethnic media outlets, and on the Internet. Each community should have sources of information about businesses that could be interested in airport concession opportunities. Getting and staying connected to the community is priceless to the airport operator and interested businesses—not just when new opportunities are available.



Strong ties to local, regional, and national business organizations also provide airport operators a wealth of information and access to companies with the breadth and depth of ability and experience required to operate in the airport environment. National airport industry organizations, such as the Airport Minority Advisory Council (AMAC), ACI-NA, AAAE, and the Airport Consultants Council (ACC), and national business organizations, such as the Women's Business Enterprise National Council (WBENC) and the National Minority Supplier Development Council (NMSDC), and other such organizations can also be sources of businesses interested in airport concession opportunities.



Timing is a critical factor in reaping the full benefit of conducting outreach activities. Outreach activities should be planned and conducted well in advance of seeking proposals for upcoming concession opportunities. When a new concession program is still in its development phase, the sooner the local and broader community is informed about the upcoming business opportunities, the better. Outreach activities may be conducted a full year before receiving proposals and repeated periodically. The objectives are to provide interested parties the time to plan how they will respond to the objectives of the airport terminal program and to allow sufficient time for securing financing and for developing teaming relationships. Some airport operators conduct regularly scheduled outreach meetings to inform the community regarding current and future planning for the airport.

Outreach meetings are held both on the airport property and off airport at a hotel or other meeting location. It is not unusual for multiple meetings to be held in different locations at different times of the day to reach the widest audience. Figure 7-1 shows a typical announcement for an outreach meeting.

In addition to introducing airport staff and informing participants of upcoming concession opportunities, outreach activities should also include an education component. Providing sessions that focus on how to conduct business with the airport allows interested parties to understand whether and how they can take advantage of opportunities. An invitation to and/or attendance at an outreach meeting does not guarantee an opportunity. It is important to educate airport boards, committees, politicians, chambers of commerce, and other airport stakeholders to minimize overly ambitious demands and expectations.

Interactions at these meetings also provide an avenue for acquiring information from interested parties and are useful in establishing business participation goals and assistance in identifying possible barriers to and opportunities for improving the process. Often general information about the

**CITY OF PHOENIX  
AVIATION DEPARTMENT**

**Terminal 4 Food and Beverage Concession Opportunities  
Outreach for Request for Proposals (RFP)**

The City of Phoenix Aviation Department is conducting a series of informational meetings for prime operators and other interested parties including ACDBE operators, in preparation for the release of a Request for Proposals (RFP) for the Terminal 4 Food and Beverage concession opportunities. This RFP will offer two prime operator food and beverage contract opportunities. Each contract opportunity will represent approximately half of the food and beverage sales in the terminal. No individual contract opportunities will be available. No retail concession opportunities are available at this time.

**The scheduled outreach meetings are:**

Date	Time	Focus
August 20	1 pm	Prime Operator
August 20	2:30 pm	General Outreach
August 30	10 am-5 pm	Business to Business Networking Event
September 21	1 pm	Prime Operator
September 21	2:30 pm	General Outreach
October 19	1 pm	Prime Operator
October 19	2:30 pm	General Outreach
November 18	8:30 am	Preproposal Meeting
November 18	10 am	General Outreach

All meetings will be held at **Phoenix Airport Marriott, 1101 N. 44<sup>th</sup> St., Phoenix, AZ.**  
To RSVP please call 602-683-xxxx or email xxxx.xxxx@phoenix.gov

**Figure 7-1. Example of an outreach meeting notice.**

different certification programs and instructions for applying for ACDBE and other certifications are also provided at outreach meetings.

Some basic sources and methods for successful outreach are the following:

- Interested parties list created by airport operator or concession manager
- Certification directories
- Local community and business organizations
- National industry organizations
- Chambers of commerce
- Notices in local media and ethnic media outlets
- Internet
- Outreach meetings and networking events

## **7.6 Methods for Achieving ACDBE Participation through Contractual Arrangements**

A thoughtfully developed ACDBE plan can guide the airport operator in determining when and how to achieve ACDBE participation. The plan begins with a commitment to the purpose of the ACDBE Program. A commitment to the purpose of the ACDBE Program means a commitment at all organizational levels, starting at the top. An assessment of airport policies, procedures, and practices that affect the solicitation process is also important, as it presents an opportunity to ensure that no barriers are constructed that might eliminate qualified and interested parties.



A well thought out and transparent contracting process, including selection criteria and contract award, are also important elements in achieving ACDBE participation. A transparent contracting process is one that is documented, open to public scrutiny, and applied consistently for each contract opportunity. The contracting process should be audited on a regular basis to ensure consistent application at each stage of the process. Along with assessing the process, it is imperative that contracting staff receive continuous training to ensure competency.

Transparency does not ensure that the contracting process is free of barriers. A transparent process allows for process review by stakeholders who may have different perspectives or who may offer alternatives to the existing process and raise questions that evoke fresh thinking about ways to level the playing field for businesses interested in airport concession opportunities. While the ACDBE plan may or may not be adjusted, awareness and informed flexibility ensure that the commitment to the objectives of the ACDBE Program and a competitive process is more likely.

ACDBE participation in airport concession programs is usually accomplished through direct leases, subleases, and joint ventures. ACDBE participation can also be accomplished through procurement and/or leasing of goods and contracting for services that concessionaires use in their operations and in management contracts and subcontracts subject to 49 CFR Part 23 requirements. Some examples are the following:

- **Direct leases.** Some airport concession programs use a model that includes smaller sized concession packages. ACDBEs and other ready, willing, and able firms pursue these opportunities as prime concessionaires and/or joint venture partners. If successful, airport operators enter into direct leases with these firms.
- **Subleases.** A prime concessionaire or developer subleases one or more concession locations to ACDBEs.
- **Joint ventures.** These frequently used arrangements in airport concession programs are defined in 49 CFR Part 23 as

an association of an ACDBE firm and one or more other firms to carry out a single, for-profit business enterprise, for which the parties combine their property, capital, efforts, skills, and knowledge, and in which the ACDBE is responsible for a distinct, clearly defined portion of the work of the contract and whose shares in the capital contribution, control, management, risks, and profits of the joint venture are commensurate with its ownership interest. Joint venture entities are not certified as ACDBEs.

- **Purchase of goods and services.** While 49 CFR Part 23 requires airport operators and concessionaires to make good faith efforts to explore all available options to achieve compliance with ACDBE goals through direct ownership arrangements, the purchase of goods and services by the airport operator or concessionaires and management contractors from certified ACDBEs can count toward participation goals.
- **Management contracts/subcontracts.** These are agreements with the airport operator or with another management contractor under which a firm directs or operates one or more business activities, the assets of which are owned, leased, or otherwise controlled by the airport operator. The managing agent generally receives, as compensation, a flat fee or a percentage of the gross receipts or profits from the business activity (other than an aeronautical activity), which must be located at an airport (which is subject to 49 CFR Part 23) and engaged in the sale of consumer goods or provision of services to the public.

Success in designing, establishing, and administering a best-in-class airport concession program requires approaches that clearly identify the goals of the concession program, including its goal for ACDBE participation. Airport operators that begin with the end in mind tend to be the most successful in developing programs that meet the test of a dynamic airport environment.



## 7.7 Evaluating Joint Venture and Subtenant Agreements

### 7.7.1 Joint Venture Agreements

In July 2008, the FAA issued guidance to assist airport operators in understanding how to credit ACDBE participation in concession joint ventures. The guidance also assists ACDBEs and non-ACDBE partners in developing joint ventures that comply with U.S. DOT regulations.

Before an agreement is approved by the airport operator as an acceptable business arrangement between the ACDBE and the airport, a master or prime concessionaire, or a developer or leasing manager, it is important that the airport operator evaluate the joint venture agreement to ensure that it is in compliance with the federal regulations and FAA guidance.

Some aspects of the joint venture agreement that the airport operator must review include organization of the venture, roles and responsibilities of the partners in the venture, as well as the ACDBE's capital investment, ownership, operation, and managerial control. Even though joint ventures are often complex, and determining how to credit the ACDBE's participation can be challenging, it is imperative that the airport operator determine how the participation of the ACDBE is counted toward its established ACDBE goals, consistent with the regulations and criteria set forth in FAA guidance.

In evaluating a joint venture, the following questions should be answered:

- Is the ACDBE certified?
- Have the joint venture agreement and other documentation been reviewed by the commercial/property management, legal, and ACDBE Program departments?
- What is the claimed ACDBE ownership?
- What are the amounts and sources of capital contributions?
- Are capital contributions commensurate with ACDBE ownership?
- How does the ACDBE participate in control of the joint venture business?
- How does the ACDBE participate in the management (overall and day-to-day) of the business?
- How does the ACDBE participate in risks and profits of the joint venture?
- Is management by the ACDBE commensurate with ownership?
- What portion of the work will the ACDBE perform? Please describe.
- Does the work assigned to the ACDBE represent a distinct and clearly defined portion of the work?

Once it is determined that the joint venture agreement is compliant and the ACDBE participation is approved for counting toward the goal, the amount of ACDBE participation is assigned. The count is determined based on the portion of gross receipts equal to the distinct, clearly defined portion of the concession work that the ACDBE performs with its own workforce.

### 7.7.2 Subtenant Agreements

Subtenant agreements (i.e., subleases) are easier to understand and usually do not require the same level of scrutiny as a joint venture agreement. Subtenants are usually responsible for all aspects of their operations. Subtenants may be franchisees or licensees or they may operate brands and concepts that they developed. Counting concession gross receipts generated by subtenants toward ACDBE goals is, for the most part, straightforward when subtenants use their own capital and workforce and manage the overall and day-to-day operations of their business.

Some aspects of the sublease arrangements that the airport operator may want to review are whether the subtenant has the same requirements as the lessor; whether administrative fees are being charged for managing the sublease; and whether provisions forbidding the subtenant from interacting with the airport's concession management team are included.



ACDBE subleases are usually with prime concessionaires that have a lease for a varying amount of real estate at the airport. These subleases may have provisions for the prime concessionaire to provide services for the ACDBE, such as management training, product placement consultation, or mystery shopping programs. Services provided by a prime for a fee should be reviewed to determine whether the fee for the services does not significantly exceed the amount for which the subtenant could secure such services on the open market. Some general tips on evaluating joint venture and sublease agreements are the following:

- Do not be afraid to ask questions. You have to understand the proposed arrangement to evaluate it.
- Review the agreement and require changes if necessary.
- Develop a plan for monitoring the agreement.
- Involve concessions and property staff throughout the process.
- Develop good working relationships and communications with participants.

While subleases and joint ventures are the primary types of arrangements with and between non-ACDBEs and ACDBEs, instruments such as leases, permits, contracts, and other arrangements are also used (e.g., management contracts and goods and services contracts). When the ACDBE's gross receipts generated by these instruments and arrangements are to be counted toward ACDBE goals, they must be evaluated to ensure that the ownership, ACDBE roles and responsibilities, and other provisions of the agreement are consistent with the requirements of the solicitation and 49 CFR Part 23.

## 7.8 Compliance Monitoring and Enforcement

Internal policies and processes for contract compliance monitoring and enforcement, including responsible parties and the scope of monitoring, should be documented and included in the airport's ACDBE plan. Primary aspects of compliance monitoring include, but are not limited to, tracking ACDBE revenue, conducting onsite reviews, and ensuring that ACDBEs are performing the roles and responsibilities specified in concession, sublease, and joint venture agreements. Some questions that should be considered in this regard are the following:

- What are the provisions of the contract that have to be monitored for contract and ACDBE Program compliance?
- What does the airport's approved ACDBE plan say?
- Is the ACDBE doing what it said it would do?

## 7.9 Attributes of Successful ACDBE Programs

Successful ACDBE Programs ensure that small businesses owned by socially and economically disadvantaged individuals (i.e., ACDBEs) have equal access to concession opportunities in accordance with federal law mandating the U.S. DOT ACDBE Program.

A critical ingredient of a successful ACDBE Program is achieving the commitment of the organization's leadership to the objectives of the program, which commitment spans across the entire organization. In addition, the objectives of the ACDBE Program should be incorporated into every function that affects the concession program, including the following:

- Outreach
- Management structure
- Concession planning and design
- Selection of concession mix
- Solicitation of bids and proposals



- Structure of agreements
- Compliance and monitoring

Additional attributes of a successful ACDBE program are transparency in the solicitation process, flexibility in making real time adjustments to the operating environment, adherence to clearly defined operating standards, and a well-trained staff that communicates openly with all airport tenants. These attributes create a positive environment for developing and implementing a successful ACDBE program.

Although successful programs may or may not exhibit every attribute mentioned above, they share some common characteristics such as a fully developed ACDBE plan; a well-defined concessions program operated in concert with the ACDBE plan; and an adequate number of staff who have the knowledge, training, and resources needed to accomplish their responsibilities.

## 7.10 Measuring Performance

Measuring the performance of an airport's ACDBE plan requires a clear set of expectations and goals for each component of the program, consistent with the expectations and goals of the concessions program. Development of the request for proposals (RFP), request for qualifications (RFQ) or request for bids (RFB) and the solicitation process are areas that can create or eliminate barriers to achieving the airport's ACDBE participation objectives. Outreach, monitoring, and compliance are other critical aspects of the ACDBE program where measuring performance will be necessary to determine whether these activities are being implemented successfully and in compliance with 49 CFR Part 23.

The purpose of outreach and how to conduct it has been described in Section 7.5. Measuring the performance of this aspect of the airport's ACDBE plan would include an assessment of whether outreach initiatives have achieved the desired objective of inclusion of ACDBEs in the concession program, and, if not, what should be changed and how.

Measuring the performance of the monitoring and compliance component of the airport's ACDBE plan requires adequate numbers and training of the staff assigned to handle the various aspects of these functions, which can include on-site reviews, monitoring timely payments to ACDBEs, reporting achievements to the FAA, and monitoring contract performance and compliance against contract provisions. Monitoring and performance measures need to be clearly stated in the agreement and include expectations related to the goals of the airport's ACDBE plan.

Making adjustments to bid requirements so that they are relevant for the specific concession opportunity is a measure of an airport's performance on eliminating barriers to ACDBE participation. The assumption that one set of requirements fits all can create a barrier that is easy to eliminate. An assessment of the bid requirements for each specific concession opportunity does not mean that the bid requirements (e.g., bonding, insurance, experience, and qualifications) will be changed for each concession opportunity. A thoughtful and thorough analysis of the requirements, using criteria reflective of the objectives to be met by the contract and the ACDBE Program, is necessary.

The airport operator should document and periodically review the solicitation process. A checklist is useful to be sure that administration of the process is consistent. Debriefing participants after each solicitation process is completed and asking questions similar to those listed below will provide information that will allow for continuous evaluation. Changes and improvements can be made when deemed necessary.

- Have we achieved our goals for outreach, monitoring, compliance, and ACDBE participation?
- Are we achieving the objectives of our ACDBE plan?



- Are we performing our responsibilities consistent with 49 CFR Part 23?
- Have there been any complaints about ACDBE policies and administration of the ACDBE plan?
- What do the bidders or proposers say about their experience with the process?
- What do interested parties that did not bid or propose on the opportunity say about their impression of the process?
- Are there any barriers?
- What have we learned?
- What needs to be changed?
- What actions need to be taken based on our findings?

Measuring performance not only is a mechanism for airport staff to be responsive to stakeholders, it helps the airport execute a successful, compliant ACDBE Program.

## 7.11 Reporting Achievements

The purpose and objectives of the airport operator's ACDBE plan and the intended achievements should be communicated during the airport operator's outreach efforts, in solicitation documents, and in contract documents to achieve the levels of ACDBE participation that the airport operator expects.

- What are achievements?
  - Achievements are expressed by the dollar value of the participation in concession contracts generated by ACDBEs, which are reported to the FAA annually. Attaining or exceeding ACDBE participation goals is an achievement.
- How are achievements tracked?
  - Achievements are tracked routinely (e.g., monthly, quarterly) by collecting and verifying ACDBE sales reports from concessionaires, as well as collecting and verifying the amounts that concessionaires pay to ACDBEs under contract with them to provide goods and/or services to the airport concession operation.
- Send achievement reports to the FAA
  - The sales generated from the commercially useful functions performed by ACDBEs on a fiscal year basis, as included in concession contracts, are reported to the FAA by March 1 each year via its web-based DBE Office Online Reporting System (DOORS). If the airport operator errs in reporting achievements, DOORS permits the airport operator to edit its report. If the report is late, the FAA will contact the airport operator. If achievements are not reported at all, the FAA may find that the airport operator failed to administer its ACDBE program in good faith.
- Tell stakeholders
  - Inform internal and external stakeholders of the airport's ACDBE achievements and successes via annual reports, on the airport's website, and through other means.

Figure 7-2 shows the FAA's Uniform Report of ACDBE Participation form.

## 7.12 Barriers to ACDBE Participation

Airport in-terminal concession programs have evolved from generic offerings in the early days to today's national and regional brands and business and personal services that rival those in some of the most upscale malls. Since the 1970s, as airport concession programs have evolved and become more sophisticated, the number, size, and types of ACDBE Program participants (e.g. concession operators, goods and services providers, and management contractors and sub-contractors) have increased.

<b>UNIFORM REPORT OF ACDBE PARTICIPATION</b>									
<b>**Please refer to the instructions sheet for directions on filling out this form**</b>									
1. Name of Recipient: AIP Numbers									
2. Contact Information: Preparer's Name: email address:		Phone No. ( )		Fax No. ( )					
3a. Federal fiscal year in which reporting period falls: FY (Oct. 1, to Sep. 30, )		3b. Date This Report Submitted:							
<b>4. Current Non-Car Rental ACDBE Goal:</b>		Race Conscious Goal %		Race Neutral Goal %		ACDBE OVERALL Goal %			
		A	B	C	D	E	F	G	
<b>5. NON-CAR RENTAL CUMULATIVE ACDBE PARTICIPATION</b>		Total Dollars (Everyone)	Total Number (Everyone)	Total to ACDBEs (dollars) [E+F]	Total to ACDBEs (number)	Total to ACDBEs /Race Conscious (dollars)	Total to ACDBEs/Race Neutral (dollars)	Percentage of total dollars to ACDBEs [C/A]	
Prime Concessions									
Subconcessions									
Management Contracts									
Goods and Services									
Total Cumulative Non-Car Rental ACDBE Participation									
		A	B	C	D	E	F	G	
<b>6. NON-CAR RENTAL NEW ACDBE PARTICIPATION THIS PERIOD</b>		Total Dollars (Everyone)	Total Number (Everyone)	Total to ACDBEs (dollars) [E+F]	Total to ACDBEs (number)	Total to ACDBEs /Race Conscious (dollars)	Total to ACDBEs/Race Neutral (dollars)	Percentage of total dollars to ACDBEs [C/A]	
Prime Concessions									
Subconcessions									
Management Contracts									
Goods and Services									
Total Non-Car Rental New ACDBE Participation									
		A	B	C	D	E	F	G	
<b>7. Current Car Rental ACDBE Goal:</b>		Race Conscious Goal %		Race Neutral Goal %		ACDBE OVERALL Goal %			
		A	B	C	D	E	F	G	
<b>8. CAR RENTAL CUMULATIVE ACDBE PARTICIPATION</b>		Total Dollars (Everyone)	Total Number (Everyone)	Total to ACDBEs (dollars) [E+F]	Total to ACDBEs (number)	Total to ACDBEs /Race Conscious (dollars)	Total to ACDBEs/Race Neutral (dollars)	Percentage of total dollars to ACDBEs [C/A]	
Prime Concessions									
Subconcessions									
Goods and Services									
Total Cumulative Car Rental ACDBE Participation									
		A	B	C	D	E	F	G	
<b>9. CAR RENTAL NEW ACDBE PARTICIPATION THIS PERIOD</b>		Total Dollars (Everyone)	Total Number (Everyone)	Total to ACDBEs (dollars) [E+F]	Total to ACDBEs (number)	Total to ACDBEs /Race Conscious (dollars)	Total to ACDBEs/Race Neutral (dollars)	Percentage of total dollars to ACDBEs [C/A]	
Prime Concessions									
Subconcessions									
Goods and Services									
Total Cumulative Car Rental New ACDBE Participation									
		A	B	C	D	E	F	G	H
<b>10. CUMULATIVE ACDBE PARTICIPATION BY RACE/GENDER</b>		Black Americans (numbers & dollars)	Hispanic Americans (numbers & dollars)	Asian-Pacific Americans (numbers & dollars)	Asian - Indian Americans (numbers & dollars)	Native Americans (numbers & dollars)	Non-Minority Women (numbers & dollars)	Other (i.e. not of any other group listed here) (numbers & dollars)	TOTALS (A+B+C+D+E+F+G) (numbers & dollars)
Car Rental									
Non-Car Rental									
Total Cumulative Race/Gender ACDBE Participation									

11. For each ACDBE firm that is participating, please fill out the attached Report of Certified ACDBE Form or list the following information for each ACDBE firm participating in your program during this report: (1) Firm name; (2) Type of business; (3) Beginning and expiration dates of agreement, including options to renew; (4) Dates that material amendments have been or will be made to agreement (if known); and (5) Estimate gross receipts for the firm during this reporting period.

Figure 7-2. Uniform report of ACDBE participation.



ACDBEs have been quite successful in creating food and retail concepts that they began as single units and that they are now operating at multiple airports. From concession program differentiation and creation of a sense of place at the local airport, to operating national brands at airports across the country, ACDBEs have contributed substantially to airports as we experience them today. While that trend is fully expected to continue into the future, there are still internal and external barriers that affect ACDBE participation in airport concessions.

For example, insufficient planning for ACDBE participation, limited outreach, and excessive contractual requirements (e.g., bonding, insurance, and experience) are some of the internal barriers to ACDBE participation in airport concession opportunities. These are barriers that airport operators have an opportunity and an obligation to address in developing and administering their ACDBE program and concession program. Internal policies, procedures, and practices can also create challenges for ACDBEs, small businesses, and operators new to the airport environment.

Concession managers that are open to new ideas and new operators for the concession program can create an operating environment and culture that encourage others to think more expansively about the program and about the opportunities. This open and thoughtful approach requires educating stakeholders and analyzing the effects of important requirements, processes, and procedures. Some actions that can be taken to reduce and eliminate internal barriers to ACDBE participation are the following:



- Evaluate the basis for certain policies, practices, and procedures to determine if they continue to be relevant and appropriate. This evaluation would apply to requirements such as years of experience and the amounts and types of bonds and insurance.
- Educate the community about the economic benefits of the airport and the opportunities that it provides to the community.
- Include the community in assessing and re-evaluating the concession program.
- Conduct sessions for potential participants, such as “How to do Business at the Airport” and “Concessions 101.”
- Inform the community of plans for updating or reinventing the airport concession program.
- Conduct outreach consistent with the market area(s) (i.e., national, regional, or local) established for each particular concession opportunity.

External barriers tend to be outside the control or influence of the airport operator, such as barriers that limit access to education, management experience, and leadership opportunities. Obtaining financial assistance for starting or expanding a business or securing franchises is a primary external barrier to ACDBE participation.

First instituting and then establishing a cap on the personal net worth of ACDBE owners also created a new hurdle for ACDBEs seeking financing to win or extend concession contracts. ACDBE business owners may begin as operators of one or more units at the local airport. If they achieve success with a concept and seek to offer the concept at other airports, access to the finances required to pay the costs associated with doing business at the second airport could be restricted, especially with a limit on the operator’s personal net worth. This restriction could hinder the operator’s ability to acquire the financing needed to expand the business. For this reason, the growth in numbers of ACDBEs has far exceeded the growth in the size of ACDBE concessionaires. Very few ACDBEs have graduated from the ACDBE Program. Others have sold their businesses to larger operators eager to gain both the real estate and the concepts that were created and developed into successful and sought-after brands.

Another challenge to growth has been the lack of uniformity in how certification eligibility is determined. ACDBE operators certified in one state may experience difficulties being certified in other states and jurisdictions. Some of these situations are being addressed through uniform certification applications and reciprocity between states, although there is room for improve-



ment and training in both areas. The U.S. DOT regulation that became effective February 28, 2011, establishes further requirements and provides guidance to help eliminate some of the barriers to ACDBE certification eligibility and interstate certification reciprocity.

### 7.13 Program Audits

All airport operators that establish and implement ACDBE programs are subject to program audits. The audits are conducted by the FAA Office of Civil Rights, which has become more systematic in conducting ACDBE program audits, with a greater number of such audits conducted in recent years. The audit entails several days of meetings with airport staff and concessionaires and site visits to concessionaires' on-airport operations, as well as reviews of the airport operator's contract files and compliance areas.

Benefits of the audit include providing assurance to airport operators that they are in compliance with 49 CFR Part 23 and offering guidance to airport operators that are not in compliance so that they can make required adjustments to their ACDBE Programs. Airport operators that do not implement their FAA-approved ACDBE Program plan could be found in noncompliance with 49 CFR Part 23 and become ineligible to receive FAA financial assistance.

### 7.14 Mentoring

Mentor/protégé relationships have achieved some level of success in the concession arena—for example, the mentor/protégé model in a program at Dallas/Fort Worth International Airport, overseen by the Marketing Department, and the mentor/protégé relationship operating in the concession environment at Portland International Airport. But mentor/protégé relationships have not achieved the same level of success in the airport concessions environment as they have in construction and professional services.

One of the first and most successful mentor/protégé programs was initiated by the Port of Portland in 1995 and is credited to the Port's Contract Manager, Ron Stempel. Based on the findings of a 1994 assessment of why small minority- and woman-owned businesses were not participating in Port projects, the Port developed a Mentor/Protégé Program. What has come to be known as The Stempel Plan has since become a national model for various agencies and organizations. It is noteworthy that the program is promoted by Associated General Contractors of America (AGC) chapters nationwide.

The five barriers identified as a result of the assessment conducted in 1994 by the Port of Portland are similar to those frequently identified by ACDBEs today. These barriers include the following:

- Ineffective relationships between prime contractors and small businesses and minority-owned and woman-owned businesses
- Poor access to job notification
- Inability to accommodate size of work
- Inability to secure adequate financing
- Inability to secure adequate bonding

Businesses that have established relationships with franchisors and/or major suppliers and that have gained the ability to purchase products and services at premium rates through mentor/protégé relationships gain an excellent opportunity for capacity building.

It is important to remember that capacity building will have the most effect on the economic growth and development of the communities where the ACDBEs reside. While few analyses of



the economic contribution of minority-owned and woman-owned businesses have been conducted, a study commissioned by the Dallas/Fort Worth International Airport Board found that 51% of retail sales at the airport from September 2002 through September 2005 occurred at minority-owned and woman-owned businesses. Those firms recorded \$287 million in sales, creating \$431 million in economic activity, adding \$157 million to regional labor income.

One difficulty that has been experienced in mentor/protégé relationships is creating a way for an ACDBE protégé to maintain independence that does not deter its ability to maintain its DBE/ACDBE certification eligibility.

Another challenge that often arises is how to count the participation by the ACDBE protégé towards ACDBE goals. There continues to be an opportunity to address these issues so that capacity building of ACDBEs, maintaining ACDBE certification, and counting participation of ACDBEs in mentor/protégé relationships can be achieved.

Airport operators seeking to implement business development programs or mentor/protégé programs in their ACDBE programs must use the U.S. DOT's business development program guidelines (Appendix C of 49 CFR Part 26) and/or its mentor/protégé program guidelines (Appendix D of 49 CFR Part 26). Both sets of guidelines offer a full discussion of the requirements, objectives, and roles and responsibilities of participants in these programs.

# Concession Contracting Approaches

One of the most fundamental decisions that an airport operator will make concerning the airport concession program is the choice of concession contracting approach (also referred to as concession management approach). This decision has implications for all aspects of the concession program. This chapter presents an overview of the four major concession management approaches in use at U.S. airports today—Direct Leasing, Prime Concessionaire, Third-Party Developer, and Leasing Manager. A “Hybrid” approach is also used at some airports, wherein two or more of the four major management approaches are used.

This chapter will provide a description of concession management approaches, including a summary of the advantages and disadvantages of each, and a discussion of financial performance by management approach that covers the topics of sales per enplaned passenger, concession space in operation, sales per square foot, and net revenue per enplaned passenger

## 8.1 Description of Concession Management Approaches

In determining the optimal management approach, the airport operator must consider a number of factors, including the following:

- The number of terminals at the airport, their layout, and the configuration of concession space and support space
- Passenger volumes and demographics
- The size and capabilities of the airport operator’s concessions staff
- Private-sector interest in the potential concession opportunities
- Projected sales and revenue under each management approach
- The airport operator’s goals and objectives
- The airport operator’s terminal development plans, and the timing of the development
- The airport sponsor’s need or desire to attract private capital
- The relative difficulty in soliciting and contracting with concessionaires under the airport operator’s policies and legal constraints
- The local political climate

### 8.1.1 Direct Leasing

Direct Leasing offers the airport operator the opportunity to plan the use of terminal concession spaces, identify individual spaces for leasing or bundle spaces into contract packages, and then select the best concessionaire to operate each space or package of spaces. This approach generally provides the airport operator with the greatest amount of control over its concession program and a high degree of competition among concessionaires.



Direct Leasing may occasionally be used to supplement a Prime Concessionaire approach, whereby the airport operator holds some locations out of the larger, multiple location package(s) offered to the Prime Concessionaire(s) to make those locations available to smaller vendors or specialized concession opportunities.

Direct Leasing works best when passenger volumes and business terms are adequate to be able to structure contract packages that can stand alone, and a sufficient number of concessionaires are interested to provide reasonable competition. It is less likely that a Direct Leasing approach will provide concessionaires with opportunities to offset low volume or unprofitable locations with returns from successful locations (as, for example, is typical with the Prime Concessionaire approach, where the Prime Concessionaire assumes the risk for marginal spaces, which is offset by the overall volume of sales, including those at high-performing spaces). To reduce risks of service deficiencies and concessionaire failures under the Direct Leasing approach, the airport operator must be able to devise business terms and conditions (term length, operational requirements, pricing policies, concession fees, buildout requirements, etc.) appropriate for each opportunity.

The competitive nature of the Direct Leasing approach, with its variety of concessionaires and brands/concepts, provides incentive to build out stores in all locations that are considered to be financially feasible, which contributes to increased revenue and greater customer satisfaction.

Implementation of the Direct Leasing approach does bring certain challenges. This approach generally requires the airport operator to have a larger staff with more skills and experience than the other concession management approaches because airport staff, under a Direct Leasing approach, must solicit, award, and implement numerous concession agreements and manage a multiconcessionaire operation. In addition, aesthetic coordination and approval of construction activities by multiple concessionaires with different architects and construction teams are required, which adds to the work of the airport's engineering and development staff.

Unlike the Prime Concessionaire and Third-Party Developer/Leasing Manager approaches, the Direct Leasing approach often requires the airport operator to make capital investments in facilities outside of the individual concessionaire locations, such as food courts.



In summary, the Direct Leasing approach provides advantages in offering concept and product variety, price and service competition, opportunities for a number of concessionaires to participate, and high sales/revenue (as discussed in Section 8.2). However, the airport operator also has greater staff costs and administrative burden in managing multiple tenants and contracts. Perhaps most importantly, the Direct Leasing approach requires the airport operator to fund and construct needed common area concession-related capital improvements or to develop strategies for constructing the common area capital improvements and incorporate them in its contracting strategy.

Some of the major airports at which the Direct Leasing concession management approach is used include Dallas/Fort Worth, Denver, Portland, and San Francisco International Airports. Each of these airports has a well-developed Direct Leasing program with participation by a significant number of local brands and local owners.

### 8.1.2 Prime Concessionaire

Under the Prime Concessionaire approach (sometimes referred to as multiple primes), the airport operator leases all of the concession space in a category to one or two concessionaires. Prime Concessionaires (Primes) generally self-operate most locations and sublease a few locations to meet the ACDBE goal, and/or to provide local or regional brands that may be desired by the airport operator, or for other reasons.

Airport operators may execute agreements with different Prime Concessionaires to operate food/beverage facilities and retail facilities, or the same Prime may operate both categories of concessions. In cases where only one company operates the vast majority of food and beverage and/or retail concessions, the term “Master Concessionaire” is used.

Use of the Prime Concessionaire approach results in fewer concession contracts for airport staff to award and manage. These contracts are awarded almost entirely to experienced national airport concessionaires. Additionally, the Prime Concessionaire approach provides for more coordinated design submittals, and construction permitting and oversight are required for fewer concessionaires. Overall, this concession management approach places considerably less oversight demand on airport concession staff and construction-related staff than the other concession management approaches.



Because of the wider exposure to enplaning passengers in the terminal, Prime Concessionaires are less vulnerable to changes in airline schedules than tenants under Direct Leasing with fewer locations. As a result of their multiple locations within the terminal, Prime Concessionaires are better able to withstand decreases in sales that may occur at particular locations resulting from factors such as gate closures or reassignments, airline relocations or service reductions, economic downturns, and construction activities. Prime Concessionaires are also usually large, well-capitalized, established firms with the financial ability to withstand most downturns.

In addition to their direct investment in concession units, the Prime Concessionaire also typically invests in the development of common areas, such as food courts and storage and support spaces.

The percentage rent and minimum rents are generally higher under the Prime Concessionaire approach as the size of the Prime Concessionaire operations yields financial economies of scale, providing Primes with a greater ability to pay higher rent. At the same time, the Prime Concessionaire approach produces lower sales compared with the other approaches (see Table 8-5), which somewhat offsets the higher rents.

The Prime Concessionaire approach is used at most small hub airports (e.g., Charleston and Tulsa International Airports) because passenger volumes are not sufficient to support multiple concession operators. The Prime Concessionaire approach is also used at many medium hub airports and at some large hub airports. For example, the Hillsborough County Aviation Authority uses the Prime Concessionaire approach at Tampa International Airport, contracting with a single Master Concessionaire, and the Port of Oakland uses a single Master Concessionaire for food and beverage and retail offerings, supplemented by a few Direct Leases with specialist operators for a small percentage of the overall concession space at Oakland International Airport. Nashville International Airport, a medium hub, has two Primes for food and beverage services.

A significant disadvantage of the Prime Concessionaire approach is that it provides the least amount of competition of any of the concession management approaches, as one or two large concessionaires effectively control the vast majority of space in a category. The only real competition under this approach may be between the Prime Concessionaire and its own subtenants, whose store locations and sublease terms and conditions are determined by the Prime. In some cases, the Prime and its subtenants may be competing for the same business, which can cause conflicts.

Another possible disadvantage is that the Prime Concessionaire may be reluctant to use its capital funds to build out stores in new locations if such stores would serve as competitors for the Prime’s existing stores or those of its subtenants.

### 8.1.3 Third-Party Developer

Under the Third-Party Developer (Developer) approach, the airport operator leases all locations in a terminal(s) to a specialist company that develops and manages the concession program.



Similar to the Direct Leasing approach, the Third-Party Developer approach provides a great degree of competition, as the Developer selects the subtenants for each location (or group of locations) that it deems best able to generate the highest sales and revenues.

The underlying premise of this approach is the alignment of Developer and airport operator interests in that both parties function in the role of landlord and do not operate any of the concessions. This approach produces highly regarded concession programs with a high degree of customer service and, for this reason, some airport operators are willing to pay the Developer a share of revenues in return for the benefit of having a professionally developed program. Rather than relying on airport staff, the Developer is delegated most decision-making authority, with some agreed-upon approvals retained by airport management, such as approval of the overall concession plan and the final slate of tenants.

Most airport operators that have selected the Third-Party Developer approach (such as the operators of Baltimore/Washington International Thurgood Marshall, Philadelphia International, and Pittsburgh International Airports) have included language in the Developer's agreement that precludes self-operation of any of the spaces to ensure that no conflict of interest exists between the Developer and its subtenants.

Another advantage of this approach is that the Third-Party Developer can more freely select and negotiate terms with its potential subtenants, rather than relying on the more rigid solicitation process used by the public sector. The Developer is free to negotiate variable or stepped percentage rents, minimum rents, and other terms that will result in the best terms for both parties.

Developers (and their subtenants) are generally expected to invest capital in development of the concession program. The Developer's investments typically include funding of basic infrastructure needs and development of common areas, such as food court seating and shared concessions support and delivery space. Subtenants are generally required to build-out their facilities; however, on occasion, the Developer may assist in subtenant build-out expenses by providing loans or seed money, particularly for small local businesses and ACDBEs. As with other management approaches, the large majority of investment under the Third-Party Developer approach is made by the tenants operating in the concession spaces.

At some airports with older terminals, the Developer approach may be used as a vehicle for improving terminal infrastructure in addition to the quantity and quality of concession space. Baltimore/Washington International Thurgood Marshall Airport is an example of an airport where the Developer approach was used to upgrade basic space and infrastructure in an older terminal area.

Because of the comprehensive nature of the Third-Party Developer approach, improvement in the concession program can be significant. For example, at the Baltimore/Washington International Thurgood Marshall Airport, the Developer made a \$20 million investment commitment (exclusive of subtenant investment) and increased sales per enplaned passenger from \$5.65 per enplaned passenger in 2004, under the former Master Concessionaire contract, to \$8.41 per enplaned passenger in 2008, under the Third-Party Developer approach—an increase of 49%. The Developer approach is also used at Newark Liberty and Boston Logan International Airports, which rank among the leaders in sales per enplaned passenger.

For many airport operators, coordinating the design and construction of multiple tenant improvements is an administrative burden for which they are not adequately staffed. The Developer will typically coordinate all subtenant design and construction on behalf of the airport operator, reducing airport staff workload considerably.

A concern often expressed about the Developer approach is that the net revenue to the airport enterprise is lower than under other approaches because of the fees required to compensate the Developer for its services. Although the potential exists for increased sales under this compre-



hensive approach, the higher sales may not be sufficient to offset the Developer's fees, which usually are in the range of 25% to 30% of subtenant concession rents.

The Developer approach also requires a considerable volume of enplaned passengers—typically, more than 5 million annual enplaned passengers—and considerable space. Therefore, small hub airports and most medium hub airports would not be viable candidates for the Third-Party Developer approach. Pittsburgh International Airport, the first U.S. airport where the Developer approach was used, falls below this threshold as a result of the decline in connecting traffic following the downsizing of US Airways, its hub carrier. However, the airport remains the overall U.S. leader in food and beverage and retail spend per enplaned passenger, at \$13.68 in 2008 according to a comparison of the top 50 performing North American airports published in the *Airport Revenue News Fact Book 2009* (Airport Revenue News 2009). (It should be noted that the Developer approach is not fully responsible for the high sales threshold, as the airport's terminal layout, which requires all passengers go through the same central concessions core on the way to their gates, is ideal.)

The level of investment associated with Third-Party Developer agreements also typically requires a longer term, usually 15 years or more, although the terms of the underlying subtenant agreements are generally similar to those under other management approaches. The longer term is needed to amortize the Developer's common-area and infrastructure investments, which are expensive and often have a long useful life.

In some cases, elected policymakers may not support delegating contracting authority to a Third-Party Developer because of concerns about the revenue effects on the airport enterprise and/or the loss of some control over the selection of concessionaires.

#### 8.1.4 Leasing Manager

The Leasing Manager approach is similar to the Third-Party Developer approach, with some significant differences. As with the Developer approach, the Leasing Manager brings expertise in commercial leasing and property management and, in return, the Leasing Manager receives a fee for its services. To ensure that no conflict of interest exists regarding the Leasing Manager's responsibilities, the Leasing Manager typically does not self-operate any spaces. Unlike a Third-Party Developer, the Leasing Manager does not make investments in the terminal. Secondly, the Leasing Manager may or may not provide oversight of tenant design and construction. Third, the Leasing Manager may or may not enter into concession agreements directly with tenants.

Fee structures under the Leasing Manager approach can vary. The Leasing Manager may receive a fixed fee for its services and/or a percentage of rentals collected from concessionaires, or some other method of payment may apply. For example, the Metropolitan Washington Airports Authority has historically required its Leasing Managers at Washington Reagan National and Washington Dulles International Airports to charge concessionaires the greater of a minimum annual guaranteed rent or a percentage of sales as a concession fee, with the Authority subsequently receiving percentage rents from the Leasing Manager based on the concession fees that the Leasing Manager collects. Because the Leasing Manager is not responsible for capital development costs, the fees for its services are lower than the fees under the Third-Party Developer approach.

The decision to use a Leasing Manager is a tradeoff between the additional costs connected with its services and the ability of the Leasing Manager to attract tenants and negotiate concession agreements for the airport operator. Airport operators that use Leasing Managers appreciate the contracting flexibility and believe that the overall result is a better program with better tenants, and they also appreciate that the increased revenue from the program substantially offsets the Leasing Manager's fees.

In some cases, elected policymakers may not support delegating contracting authority to a Leasing Manager that has no real investment in the airport. Elected policymakers may also not support



delegating contracting authority to a Leasing Manager if the basis for soliciting and selecting tenants is not transparent or if the costs of the Leasing Manager reduce revenues to the airport operator.

### 8.1.5 Hybrid Approach

Practical considerations may result in the use of more than one contracting approach at an airport. For example, at Seattle-Tacoma International Airport, multiple Prime Concessionaires are used for concessions on the concourses, and the Direct Leasing approach is used in the Central Terminal, which is themed as the Seattle Marketplace. Further, the Central Terminal marketing, leasing, and development was performed by a Leasing Manager on behalf of the Port of Seattle. Airport management believed it could use a conventional Prime Concessionaire approach for its concourses, but the new Central Terminal, a major centralized post-security concession development, was intended to be a showcase, and a Leasing Manager was considered the best way to attract and contract with tenants who may be wary of conventional public-sector contracting practices. The strategy at the Seattle airport was successful. After the Central Terminal was opened, airport staff assumed responsibility for its management.

At some other large airports, a combination of leasing approaches is also used. For example, at John F. Kennedy International Airport, a Master Concessionaire has executed a food and beverage agreement in JetBlue Airways' Terminal 5, and Direct Leasing is used in the airport's Terminal 4, where the concession program is managed by the terminal operator using Direct Leasing. A Third-Party Developer manages the pre-security central terminal retail program at Orlando International Airport, while multiple Primes operate the concessions in other areas of the terminal complex. A Third-Party Developer operates the concessions in the central terminal areas at Miami International Airport, and Primes and Direct Leasing are used in most other areas of the terminal complex. Two Third-Party Developers operate at Boston Logan International Airport, each managing the concessions in two of the airport's four terminals.

For these reasons, the Hybrid approach is more of a contracting strategy than an approach, with the airport operator using each approach as a tool to achieve the best overall program for its unique circumstances.

### 8.1.6 Summary of Concession Management Approaches

No single concession management approach can or should be universally applied. Airport operators must decide which approach offers the best outcome in light of the opportunities and challenges it presents. This decision is best made after careful analysis of the costs and benefits of each approach. Table 8-1 presents a high-level summary of the relative strengths of each approach

**Table 8-1. Summary of relative strengths of major concession management approaches.**

	Competition	Capital investment	Airport administrative costs	Financial return
Direct Leasing	High	High	High	High
Prime Concessionaire	Medium	High	Low	Medium
Third-Party Developer	High	High	Medium	Medium
Leasing Manager	High	n.a.	Medium	Medium

n.a. = Not applicable.

in terms of (1) competition, (2) ability to invest capital, (3) the associated airport administrative costs, and (4) the financial return to the airport enterprise associated with each approach.

Table 8-2 presents a summary of the advantages and disadvantages of each concession management approach. The following section presents a comparison of the revenue to the airport enterprise produced under each approach.

**Table 8-2. Summary comparison of concession management approaches.**

<p><b>THIRD-PARTY DEVELOPER</b></p> <p><b>Advantages:</b></p> <ul style="list-style-type: none"> <li>• Lowest administrative burden, as Developer brings professionals with experience in marketing, leasing, developing, and managing food and retail spaces; single point of contact for airport management</li> <li>• Coordinates all tenant design and construction</li> <li>• Generally enters into subcontracts directly with subtenants and is able to negotiate optimal business terms (compared with public procurement requirements)</li> <li>• Does not compete with tenants; shares goal of airport operator in maximizing sales, service</li> <li>• Develops food courts and other common areas; makes investment in common areas, directories, etc.</li> <li>• Variety of shops, concepts, subtenants creates high degree of competition and choices for customers</li> </ul> <p><b>Disadvantages:</b></p> <ul style="list-style-type: none"> <li>• Considerable potential sales volumes are necessary for Third-Party Developers to participate</li> <li>• Requires longer term, typically 15 years, for Developer to earn satisfactory returns</li> <li>• Developer takes cut of concession sales, which may reduce airport operator's concession revenues below potential of other approaches</li> </ul> <p><b>LEASING MANAGER</b></p> <p><b>Advantages:</b></p> <ul style="list-style-type: none"> <li>• Similar to Third-Party Developer, brings professionals with experience in marketing, leasing, developing, and managing food and retail spaces; single point of contact for airport management</li> <li>• Scope may include coordination of design and construction activities</li> <li>• May (or may not) enter into agreements directly with subtenants; able to negotiate optimal business terms (compared with public procurement requirements)</li> <li>• Variety of stores/concepts operated by different concessionaires creates distinct customer shopping choices and a high degree of competition</li> </ul> <p><b>Disadvantages:</b></p> <ul style="list-style-type: none"> <li>• Airport operator has responsibility for common area build-outs</li> <li>• Leasing Manager receives a fee for its services, which may reduce airport concession revenues</li> <li>• Typically works on a fee basis and does not make capital investment in common areas, directories, etc.</li> </ul>
---

*(continued on next page)*

**Table 8-2. (Continued).**

<p><b>DIRECT LEASING</b></p> <p><b>Advantages:</b></p> <ul style="list-style-type: none"> <li>• Direct relationship between airport operator and concessionaires</li> <li>• Variety of stores/concepts operated by different concessionaires creates distinct customer shopping choices and a high degree of competition</li> <li>• Airport operator controls overall scope of program</li> </ul> <p><b>Disadvantages:</b></p> <ul style="list-style-type: none"> <li>• Requires the most airport staff time and expertise due to variety of individual concession agreements to award and manage</li> <li>• Airport operator has responsibility for common-area build-outs</li> <li>• Design and construction activities by many different firms increases workload for airport operator</li> <li>• Greater risk of failure, as individual agreements must be self sufficient; greater exposure to traffic risks</li> <li>• If local businesses are targeted, training will be required; there may be operating risks associated with inexperienced concessionaires</li> </ul> <p><b>PRIME CONCESSIONS</b></p> <p><b>Advantages:</b></p> <ul style="list-style-type: none"> <li>• Only a few points of contact for coordination of design and construction activities, depending on number of primes</li> <li>• Primes typically handle common-area build out, such as food courts</li> <li>• Requires less airport staff time (compared with Direct Leasing) with fewer, larger concession agreements to manage</li> <li>• Prime subleases to ACDBEs and others on behalf of airport</li> </ul> <p><b>Disadvantages:</b></p> <ul style="list-style-type: none"> <li>• Less competition than other management approaches</li> <li>• Variety of stores/concepts offered are often more limited due to pre-established agreements with certain brands</li> <li>• Approach (on average) results in development of less space compared with other approaches</li> <li>• Prime concessionaire may be in competition with sub-tenants</li> <li>• Lower sales compared with other approaches, although percentage rents are typically higher</li> </ul>
---

## 8.2 Financial Performance by Management Approach



A number of factors are involved in the choice of concession management approach, but the one factor that is universally considered is revenue to the airport enterprise. In this section, the financial performance of the various concession management approaches is analyzed in terms of the sales and revenue performance of airports where each management approach is in effect.

Financial performance was analyzed using data for the busiest 35 airports in the United States, mostly large hubs (and a few medium hubs), regarding concession space, sales, and revenue data

reported in the *Airport Revenue News Fact Book 2009* for calendar year 2008 (Airport Revenue News 2009).

Airports with passenger traffic less than that of the least busy of the top 35 airports (i.e., below 5.5 million annual enplaned passengers) are considered too small for the Third-Party Developer approach; generally, the Prime Concessionaire or Direct Leasing approach is used at these airports. Therefore, only the busiest 35 airports, which are capable of supporting and implementing any of the concession management approaches, were considered in the analysis.

Because of incomplete reporting of sales data, Cleveland Hopkins International Airport was eliminated from the analysis. At the time this analysis was conducted, the airport was in transition from the Prime Concessionaire approach to the Third-Party Developer approach. Pittsburgh International Airport (which has the highest spend rate per enplaned passenger in the United States) was also excluded from the analysis as it falls outside of the top 35 airports in terms of numbers of enplaned passengers.

### 8.2.1 Classification of Airports

Each airport included in the analysis was classified according to its management approach. Airports where two or more management approaches are used were placed in the Hybrid classification. The Hybrid approach, as referred to in this section, should be considered an eclectic approach and not an end in itself. Some airports classified as Hybrid have Third-Party Developer agreements, including New York's John F. Kennedy International and LaGuardia airports, and Bush Intercontinental Airport/Houston. Miami and Orlando International Airports employ Direct Leasing, Prime Concessionaire, and Third-Party Developer approaches. Including these airports allows all of the airports to be classified and compared in terms of average sales, space, and revenue.

The Third-Party Developer and Leasing Manager approaches have many similarities, with the lack of investment on the part of the Leasing Manager being the major difference. Therefore, the two categories were combined for this analysis.

Table 8-3 presents a summary of enplaned passengers, sales, and space by concession management approach for the airports included in the analysis. Six airports used the Third Party Developer/Leasing Manager management approach, 9 used the Direct Leasing approach, 8 used the Hybrid approach, and 11 used the Prime Concessionaire approach.

Table 8-4 presents a summary of revenue received by the airport operator from food and beverage and retail sales, revenue per enplaned passenger, and effective percentage rent for the airports included in the analysis (i.e., airports that provided revenue data to Airport Revenue News).

### 8.2.2 Summary of the Analysis

Table 8-5 presents a summary of sales per enplaned passenger for each concession management approach calculated using the total sales at airports in each category divided by total enplaned passengers. Where indicated, an average for all airports included in this analysis is shown. The highest sales per enplaned passenger for each sales category is indicated in boldface. Table 8-5 shows that, on average, the Third-Party Developer/Leasing Manager approach produced the highest total spend rate per enplaned passenger, followed by the Direct Leasing and Hybrid approaches. The Prime Concessionaire approach had the lowest average sales per enplaned passenger.

In the food and beverage category, the highest spend rate was achieved under the Direct Leasing approach, followed closely by the Developer/Leasing Manager approach and the Hybrid approach. The Prime Concessionaire approach again resulted in the lowest spend rate.

The Direct Leasing approach produced the highest specialty retail spend rate, followed by the Developer/Leasing Manager and Hybrid approaches. Information on retail spending for two airports where the Prime Concessionaire approach is used was categorized by specialty and conven-



**Table 8-3. Summary of enplaned passengers, space, and sales by concession management approach—2008.**

Concession management approach	Enplaned passengers (millions)	Enplaned passengers rank	Food & beverage and retail (excluding duty free)			
			Sales per enplaned passenger	Total sales (millions)	Square feet per 1,000 enplaned passengers	Average sales per square foot
<b>DEVELOPER/LEASING MANAGER</b>						
Newark	17.7	12	\$10.57	\$ 187.1	8.3	\$1,278
Philadelphia	15.8	19	\$8.60	\$ 136.3	7.3	\$1,178
Boston	13.0	20	\$10.19	\$ 132.3	11.7	\$868
Washington Dulles	11.9	21	\$8.48	\$ 100.5	13.0	\$654
Baltimore	10.2	25	\$8.41	\$ 86.1	8.3	\$1,007
Washington Reagan	9.0	29	\$9.01	\$ 80.8	7.1	\$1,269
<b>Total / Average</b>	<b>77.6</b>		<b>\$9.32</b>	<b>\$ 723.1</b>	<b>9.2</b>	<b>\$1,008</b>
<b>DIRECT LEASING</b>						
Dallas/Fort Worth	29.0	4	\$8.39	\$ 243.1	7.7	\$1,090
Denver	25.7	5	\$8.42	\$ 216.0	6.1	\$1,371
Las Vegas	22.1	7	\$10.10	\$ 223.1	5.9	\$1,721
Phoenix	19.8	9	\$8.57	\$ 169.8	7.6	\$1,123
San Francisco	18.5	10	\$11.70	\$ 216.8	8.2	\$1,422
Detroit	17.5	13	\$9.07	\$ 158.6	7.4	\$1,219
Minneapolis	17.0	16	\$8.98	\$ 152.3	9.2	\$974
Portland	7.2	33	\$10.44	\$ 74.7	10.8	\$971
Kansas City	5.5	39	\$4.97	\$ 27.5	11.1	\$449
<b>Total / Average</b>	<b>162.3</b>		<b>\$9.14</b>	<b>\$ 1,481.9</b>	<b>7.6</b>	<b>\$1,196</b>
<b>HYBRID</b>						
Chicago O'Hare	34.0	2	\$8.58	\$ 291.9	3.5	\$2,453
New York - Kennedy	23.9	6	\$11.84	\$ 282.8	9.2	\$1,286
Houston Bush Intercontinental	21.6	8	\$4.73	\$ 102.2	4.1	\$1,152
Orlando	18.2	11	\$9.29	\$ 169.4	8.6	\$1,082
Miami	17.0	15	\$9.92	\$ 169.0	9.3	\$1,073
Seattle	16.1	18	\$9.60	\$ 154.4	7.1	\$1,354
New York - LaGuardia	11.6	23	\$8.79	\$ 101.7	7.7	\$1,140
Chicago Midway	8.2	31	\$8.24	\$ 67.8	5.2	\$1,573
<b>Total / Average</b>	<b>150.6</b>		<b>\$8.89</b>	<b>\$ 1,339.2</b>	<b>6.6</b>	<b>\$1,355</b>
<b>PRIME CONCESSIONAIRE</b>						
Atlanta	45.1	1	\$7.55	\$ 340.5	4.2	\$1,812
Los Angeles	29.9	3	\$8.93	\$ 267.2	4.9	\$1,817
Charlotte	17.4	14	\$8.12	\$ 141.0	4.6	\$1,775
Fort Lauderdale	11.6	22	\$6.77	\$ 78.5	6.6	\$1,020
Salt Lake City	10.4	24	\$7.39	\$ 76.8	5.8	\$1,275
Tampa	9.1	26	\$8.66	\$ 79.2	10.3	\$840
Houston Hobby	9.1	27	\$3.04	\$ 27.7	2.8	\$1,067
San Diego	9.1	28	\$8.02	\$ 72.7	5.5	\$1,470
St. Louis	7.2	32	\$7.70	\$ 55.5	10.0	\$771
Cincinnati	6.8	34	\$7.28	\$ 49.5	16.1	\$453
Oakland	5.7	37	\$6.26	\$ 36.0	3.1	\$1,992
<b>Total / Average</b>	<b>161.4</b>		<b>\$7.59</b>	<b>\$ 1,224.6</b>	<b>5.7</b>	<b>\$1,330</b>
		Count				
DEVELOPER/LEASING MANAGER	77.6	6	\$9.32	\$ 723.1	9.2	\$1,008
DIRECT LEASING	162.2	9	\$9.14	\$ 1,481.9	7.6	\$1,196
HYBRID	150.7	8	\$8.89	\$ 1,339.3	6.6	\$1,355
PRIME CONCESSIONAIRE	161.4	11	\$7.59	\$ 1,224.6	5.7	\$1,330
<b>Total / Average</b>	<b>551.9</b>	<b>34</b>	<b>\$8.64</b>	<b>\$ 4,768.9</b>	<b>6.4</b>	<b>\$1,347</b>

Note: Cleveland Hopkins airport reported on food and beverage sales but not retail and is excluded from the analysis.

Source: Top 34 airports reporting data to *Airport Revenue News* for food and beverage and retail Calendar Year 2008. (Airport Revenue News 2009).

ience retail; therefore, the analysis does not show either category for the Prime Concessionaire approach. (Excluding those two airports, the other airports where the Prime Concessionaire approach is used had specialty retail sales averaging \$1.09 per enplaned passenger). The Developer/Leasing Manager approach produced sales per enplaned passenger that were \$0.68 or 8% above the average for all approaches and \$1.73 or 23% above the Prime Concessionaire average.

The Developer/Leasing Manager approach resulted in the highest average total retail spend per enplaned passenger, followed by the Hybrid and Direct Leasing approaches. The results for the



**Table 8-4. Summary of revenue, revenue per enplaned passenger, and average effective percentage rent by concession management approach—2008.**

Concession management approach	Enplaned passengers (millions)	Enplaned passenger Rank	Food & beverage and retail (excluding duty free)			
			Total sales (millions)	Revenue to airport (millions)	Revenue per enplaned passenger	Effective percentage rent
<b>DEVELOPER/LEASING MANAGER</b>						
Newark	–	12	\$ –	\$ –	–	–
Philadelphia	–	19	–	–	–	–
Boston	–	20	–	–	–	–
Washington Dulles	–	21	–	–	–	–
Baltimore	10,242,269	25	86,089,458	11,662,602	\$1.14	13.5%
Washington Reagan	8,976,979	29	80,842,249	10,283,012	\$1.15	12.7%
<b>Total / Average</b>	<b>19,219,248</b>		<b>\$ 166,931,707</b>	<b>\$ 21,945,614</b>	<b>\$1.14</b>	<b>13.1%</b>
<b>DIRECT LEASING</b>						
Dallas/Fort Worth	–	4	\$ –	\$ –	\$0.00	–
Denver	25,650,243	5	216,042,542	30,394,834	\$1.18	14.1%
Las Vegas	22,086,022	7	223,100,666	28,427,558	\$1.29	12.7%
Phoenix	19,816,493	9	169,782,675	23,162,937	\$1.17	13.6%
San Francisco	18,528,274	10	216,789,473	30,127,331	\$1.63	13.9%
Detroit	17,495,850	13	158,602,837	24,355,204	\$1.39	15.4%
Minneapolis	16,955,473	16	152,343,897	21,983,508	\$1.30	14.4%
Portland	7,150,857	33	74,669,450	8,643,246	\$1.21	11.6%
Kansas City	5,527,549	39	27,459,508	2,913,361	\$0.53	10.6%
<b>Total / Average</b>	<b>133,210,761</b>		<b>\$ 1,238,791,048</b>	<b>\$ 170,007,979</b>	<b>\$1.28</b>	<b>13.7%</b>
<b>HYBRID</b>						
Chicago O'Hare	–	2	\$ –	\$ –	\$0.00	–
New York - Kennedy	–	6	–	–	\$0.00	–
Houston Bush Intercontinental	21,623,261	8	102,230,762	12,923,227	\$0.60	12.6%
Orlando	18,238,277	11	169,404,326	24,108,082	\$1.32	14.2%
Miami	17,035,400	15	169,021,114	21,752,300	\$1.28	12.9%
Seattle	16,084,939	18	154,428,491	20,828,036	\$1.29	13.5%
New York - LaGuardia	–	23	–	–	\$0.00	–
Chicago Midway	–	31	–	–	\$0.00	–
<b>Total / Average</b>	<b>72,981,877</b>		<b>\$ 595,084,693</b>	<b>\$ 79,611,645</b>	<b>\$1.09</b>	<b>13.4%</b>
<b>PRIME CONCESSIONAIRE</b>						
Atlanta	45,090,314	1	\$ 340,549,351	\$ 46,098,718	\$1.02	13.5%
Los Angeles	29,928,150	3	267,219,616	43,891,036	\$1.47	16.4%
Charlotte	–	14	–	–	\$0.00	–
Fort Lauderdale	11,586,568	22	78,464,793	14,990,435	\$1.29	19.1%
Salt Lake City	–	24	–	–	\$0.00	–
Tampa	9,142,879	26	79,203,615	14,800,410	\$1.62	18.7%
Houston Hobby	9,120,970	27	27,720,844	4,652,298	\$0.51	16.8%
San Diego	9,066,343	28	72,708,235	10,487,922	\$1.16	14.4%
St. Louis	7,207,890	32	55,470,330	6,678,414	\$0.93	12.0%
Cincinnati	–	34	–	–	\$0.00	–
Oakland	5,749,093	37	35,993,456	5,928,517	\$1.03	16.5%
<b>Total / Average</b>	<b>126,892,207</b>		<b>\$ 957,330,240</b>	<b>\$ 147,527,750</b>	<b>\$1.16</b>	<b>15.4%</b>
		Count				
DEVELOPER/LEASING MANAGER	19,219,248	2	\$ 166,931,707	\$ 21,945,614	\$1.14	13.1%
DIRECT LEASING	133,210,761	8	1,238,791,048	170,007,979	\$1.28	13.7%
HYBRID	72,981,877	4	595,084,693	79,611,645	\$1.09	13.4%
PRIME CONCESSIONAIRE	126,892,207	8	957,330,240	147,527,750	\$1.16	15.4%
<b>Total / Average</b>	<b>352,304,093</b>	<b>22</b>	<b>\$ 2,958,137,688</b>	<b>\$ 419,092,988</b>	<b>\$1.19</b>	<b>14.2%</b>

Note: Cleveland Hopkins airport reported on food and beverage sales but not retail and is excluded from the analysis.  
Source: Top 34 airports reporting data to *Airport Revenue News* for food and beverage and retail Calendar Year 2008. (Airport Revenue News 2009).

Prime Concessionaire approach were again last, trailing the Developer/Leasing Manager approach by \$1.07 per enplaned passenger. The Prime Concessionaire approach also resulted in \$0.64 per enplaned passenger below the overall average for all concession management approaches.

Table 8-6 presents a comparison of the average spend rate per enplaned passenger for the 34 airports included in the analysis for each concession management approach. The highest spend rate per passenger for each sales category is indicated in boldface. The Prime Concessionaire approach had lower than average rates for total spending, food and beverage spending, and retail spending

**Table 8-5. Passenger spend rates by concession management approach—2008.**

	Sales per enplaned passenger				
	Total	Food and beverage	Specialty retail (1)	Convenience retail (1)	Total retail
Direct leasing	\$ 9.14	<b>\$ 5.60</b>	<b>\$ 1.99</b>	\$ 1.54	\$ 3.53
Prime concessionaire	\$ 7.59	\$ 4.89	n.a.	n.a.	\$ 2.69
Developer/leasing manager	<b>\$ 9.32</b>	\$ 5.56	\$ 1.82	\$ 1.94	<b>\$ 3.76</b>
Hybrid	\$ 8.89	\$ 5.32	\$ 1.56	<b>\$ 2.00</b>	\$ 3.56
Average—all airports	\$ 8.64	\$ 5.31	\$ 1.53	\$ 1.80	\$ 3.33

n.a. = Not available.

(1) Two airports in this category do not break out specialty retail from total retail.

Source: Airport Revenue News 2009. Data for 2008.

per enplaned passenger. All other approaches resulted in above average total rates for food and beverage and total retail.

Table 8-7 summarizes the ranking of concession management approaches in terms of sales per enplaned passenger for each category (food and beverage, specialty and convenience retail, and total retail).

### 8.2.3 Space Comparison

The data suggest that differences in the performance of the concession management approaches may result, in part, from the differences in the quantity of concession space developed under each approach. Figure 5-2 in Chapter 5 presented the relationship between the amount of concession space (per 1,000 enplaned passengers) and the average spend per enplaned passenger. The data show that, on average, airports at which the Developer/Leasing Manager approach is used have considerably more concession space in service for food and beverage and overall retail services.

Table 8-8 shows the average concession space per 1,000 enplaned passengers organized by concession management approach and major category. At airports using the Developer/Leasing Manager approach, there is typically less convenience retail space, but more specialty retail space in operation, and the most overall retail space in service. At airports using the Prime Concessionaire approach, the lowest total concession space was allocated for food and beverage and specialty retail, and the highest was allocated for convenience retail. In terms of total retail space, Prime Conces-

**Table 8-6. Sales per enplaned passenger by management approach as percent of group average—2008.**

	Percent of Average Sales per Enplanement				
	Total	Food and beverage	Specialty retail (1)	Convenience retail (1)	Total retail
Direct leasing	106%	<b>105</b>	130%	86%	106%
Prime concessionaire	88%	92%	n.a.	n.a.	81%
Developer/leasing manager	<b>108%</b>	<b>105%</b>	<b>119%</b>	108%	<b>113%</b>
Hybrid	103%	100%	102%	<b>111%</b>	107%
Average—all airports	100%	100%	100%	100%	100%

n.a. = Not available.

(1) Two airports in this category do not break out specialty retail from total retail.

Source: Airport Revenue News 2009. Data for 2008.

**Table 8-7. Ranking of sales per enplaned passenger by management approach—2008.**

	Sales per enplaned passenger - rank among management approaches				
	Total	Food and beverage	Specialty retail (1)	Convenience retail (1)	Total retail
Direct leasing	2	1	1	3	3
Prime concessionaire	4	4	<i>n.a.</i>	<i>n.a.</i>	4
Developer/leasing manager	1	2	2	2	1
Hybrid	3	3	3	1	2

*n.a.* = Not available.

(1) Two airports in this category do not break out specialty retail from total retail.

Source: Airport Revenue News 2009. Data for 2008.

sionaires had only 61% and 69% of the total retail space compared with the Developer/Leasing Manager and Direct Leasing approaches, respectively.

Table 8-9 presents a comparison of concession space per 1,000 enplaned passengers with the overall average for the concession management approaches on a percentage basis, with the values presented in Table 8-8 expressed as a percentage of the overall airport average. The highest percentage for each sales category is indicated in boldface. The data suggest that the airports where the Developer/Leasing Manager approach is used have, on average, more space than the average of the 34 airports analyzed. On the other hand, airports where the Prime Concessionaire approach is used have less space than the average of the airports analyzed.

The data presented in Tables 8-8 and 8-9 suggest that

- Third-Party Developers/Leasing Managers are incentivized to develop the most concession space at airports, as additional space maximizes overall sales and revenue to the airport enterprise, and these concession managers share in the revenue. As private companies, Third-Party Developers (and Leasing Managers) have more latitude in negotiating business terms and entering into leases. Airports where the Third-Party Developer/Leasing Manager approach is used performed slightly below airports where the Direct Leasing approach is used in sales per enplaned passenger in the food and beverage category, but performed better in the retail category. On the whole, airports where the Third-Party Developer/Leasing Manager approach is used performed only about 2% better in sales per enplaned passenger than airports where the Direct Leasing approach was used, or about \$0.23 per enplaned passenger.

**Table 8-8. Concession space per 1,000 enplaned passengers by management approach—2008.**

	Square feet per 1,000 enplaned passengers				
	Total	Food and beverage	Specialty retail (1)	Convenience retail (1)	Total retail
Direct leasing	7.6	4.8	1.9	1.0	2.9
Prime concessionaire	5.7	3.7	<i>n.a.</i>	<i>n.a.</i>	2.0
Developer/leasing manager	9.2	5.9	2.0	1.3	3.3
Hybrid	6.6	3.9	1.5	1.1	2.6
Average—all airports	7.0	4.4	1.5	1.1	2.6

*n.a.* = Not available.

(1) Two airports in this category do not break out specialty retail from total retail.

Source: Airport Revenue News 2009. Data for 2008.

**Table 8-9. Concession space per 1,000 enplaned passengers as a percent of the overall management approach average—2008.**

	Square feet per 1,000 enplaned passengers as percent of average				
	Total	Food and beverage	Specialty retail (1)	Convenience retail (1)	Total retail
Direct leasing	109%	108%	123%	92%	110%
Prime concessionaire	81%	84%	<i>n.a.</i>	<i>n.a.</i>	77%
Developer/leasing manager	<b>132%</b>	<b>135%</b>	<b>129%</b>	<b>124%</b>	<b>127%</b>
Hybrid	94%	90%	100%	101%	100%
Average—all airports	100%	100%	100%	100%	100%

*n.a.* = Not available.

(1) Two airports in this category do not break out specialty retail from total retail.

Source: Airport Revenue News 2009. Data for 2008.

- Airports utilizing the Direct Leasing concession management methodology are also incentivized to develop more space as the additional space maximizes overall sales and revenue to the airport enterprise. With more specialist food and beverage and retail tenants competing for business, airports that utilize the Direct Leasing management approach perform better than airports where either the Hybrid or Prime Concessionaire approach is used. Airports where the Direct Leasing approach is used rank second in terms of developed concession space.
- Airports where the Prime Concessionaire approach is used had the lowest ratio of space to passengers. In most cases, the operators of these airports must work through the Prime Concessionaire to develop additional space. A right-of-first-refusal clause is typically included in agreements with Prime Concessionaires, which gives the Prime Concessionaire first choice on developing space. However, the airport operator must convince the Prime Concessionaire that the marginal contribution from additional concession space will exceed its marginal cost, that is, it will not reduce the Prime Concessionaire's return on investment, particularly if the new space will compete with existing space. The additional investment may also lower the overall return on investment under the Prime Concessionaire agreement.

### 8.2.4 Sales per Square Foot

Sales per square foot is a measure of the productivity of concession space, and can be an indicator of or surrogate for assessing concessionaire profitability, as the measure relates investment (square footage) with sales. Sales per square foot is not a measure of profitability for the airport enterprise, however, as airports with very limited concession space may have high sales per square foot and at the same time are likely to have low sales per enplaned passenger. Sales per enplaned passenger is the best measure of overall concession performance.

Table 8-10 shows the sales per square foot for each concession management approach, by category. The highest sales per square foot for each sales category is indicated in boldface. The Prime Concessionaire approach produces the lowest overall sales per enplaned passenger (see Table 8-5) and the highest sales per square foot. High sales per square foot may be good for concessionaires, in that it indicates good return on investment, but it is not necessarily good for the airport operator, which could maximize total sales and revenue by developing more space. For example, Newark Liberty, John F. Kennedy, Boston Logan, and Portland International Airports have some of the highest total spend rates, while their average sales per square foot are near or below the overall average (see Table 8-3).

### 8.2.5 Percentage Rents

Of the 34 airports included in the analysis, 22 reported net revenue data. Based on the reported data, the average effective rent can be calculated. The effective rent is total revenue divided by total

**Table 8-10. Sales per square foot by concession management approach—2008.**

	Sales per square foot				
	Total	Food and beverage	Specialty retail (1)	Convenience retail (1)	Total retail
Direct leasing	\$ 1,196	\$ 1,176	\$ 1,051	\$ 1,577	\$ 1,230
Prime concessionaire	\$ 1,330	\$ 1,323	<i>n.a.</i>	<i>n.a.</i>	\$ 1,343
Developer/leasing manager	\$ 1,008	\$ 936	\$ 917	\$ 1,467	\$ 1,136
Hybrid	\$ 1,355	\$ 1,351	\$ 1,014	\$ 1,858	\$ 1,361
Average—all airports	\$ 1,234	\$ 1,210	\$ 991	\$ 1,685	\$ 1,275

*n.a.* = Not available.

(1) Two airports in this category do not break out specialty retail from total retail.

Source: Airport Revenue News 2009. Data for 2008.

sales, and takes into account different rent structures for tenants in the same category. The results are shown in Table 8-11. Only the total retail average percentage rent is shown for the Prime Concessionaire approach as two airports did not break out their space and sales into specialty retail and convenience retail sub-categories.

The average effective rent for all airports was 14.2%. Airports using the Prime Concessionaire approach had the highest effective rent, 15.4% overall, or 1.2% percent of sales above the group average. Third-Party Developers had an average effective rent of 13.1%, or 1.1% below the group average. Direct Leasing airports averaged 13.7%, or about 0.5% below the overall average. If the sales for each approach were equal, this might suggest that the Prime Concessionaire approach would yield the highest revenue. However, the sales are not equal for each management approach.

Adjusting the average percentage rent shown in Table 8-11 for the difference in sales per enplaned passenger shown in Table 8-5 results in the following effective percentage rent for each management approach, as shown in Table 8-12. The effective percentage rent for an airport or a category can be calculated by dividing the rent paid to the airport by the sales. Note that it is possible that high Minimum Annual Guarantees may result in high effective rents as the total Minimum Annual Guarantee may exceed the percentage rents that would be due under the concession agreement.

When the difference in sales performance for each management approach is factored in, the difference in the effective rent narrows considerably. Direct Leasing results in the highest overall return on sales (14.5%), followed by the Developer, Hybrid, and Prime Concessionaire approaches. The Prime Concessionaire approach, which results in the highest average rent, compares less favorably when the difference in sales performance for each approach is considered. In the food and beverage category, the Developer/Leasing Manager approach produces the highest return on sales,

**Table 8-11. Average percentage rent by management approach and category—2008.**

	Effective percentage rent					Number of Airports
	Total	Food and beverage	Specialty retail (1)	Convenience retail (1)	Total retail	
Direct leasing	13.7%	12.5%	15.7%	15.7%	15.7%	8
Prime concessionaire	15.4%	14.1%	<i>n.a.</i>	<i>n.a.</i>	17.9%	8
Developer/leasing manager	13.1%	12.7%	13.1%	14.6%	13.8%	2
Hybrid	13.4%	12.1%	13.8%	16.4%	15.2%	4
Average—all airports	14.2%	13.0%	15.6%	16.6%	16.1%	14

*n.a.* = Not available.

(1) Two airports in this category did not break out specialty retail from total retail.

Source: Airport Revenue News 2009. Data for 2008.



**Table 8-12. Effective percentage rent by management approach adjusted for sales performance—2008.**

	Effective percentage rent adjusted for differences in sales performance					Number of Airports
	Total	Food and beverage	Specialty retail (1)	Convenience retail (1)	Total retail	
Direct leasing	14.5%	13.2%	20.4%	13.5%	16.7%	8
Prime concessionaire	13.5%	13.0%	<i>n.a.</i>	<i>n.a.</i>	14.5%	8
Developer/leasing manager	14.2%	13.3%	15.6%	15.7%	15.7%	2
Hybrid	13.8%	12.1%	14.1%	18.3%	16.3%	4
Average—all airports	14.2%	13.0%	15.6%	16.6%	16.1%	14

n.a. = Not available.

(1) Two airports in this category did not break out specialty retail from total retail.

Source: Airport Revenue News 2009. Data for 2008.

with Direct Leasing a close second. In the total retail category, the Direct Leasing approach produces the highest return on sales, followed by the Hybrid, Developer, and Prime Concessionaire approaches.

The Prime Concessionaire approach would produce the highest return on sales if all management approaches resulted in identical sales. However, this is not the case. The Direct Leasing and Developer/Leasing Manager approaches, each of which creates incentives to develop the most space and the highest sales, produce higher revenues, as shown in Table 8-12.

Figure 8-1 presents a comparison of the average sales per enplaned passenger and average effective rent by concession management approach. The columns represent the average sales per enplaned passenger (labeled on left axis) and the diamonds represent the average effective percentage rent (labeled on right axis).

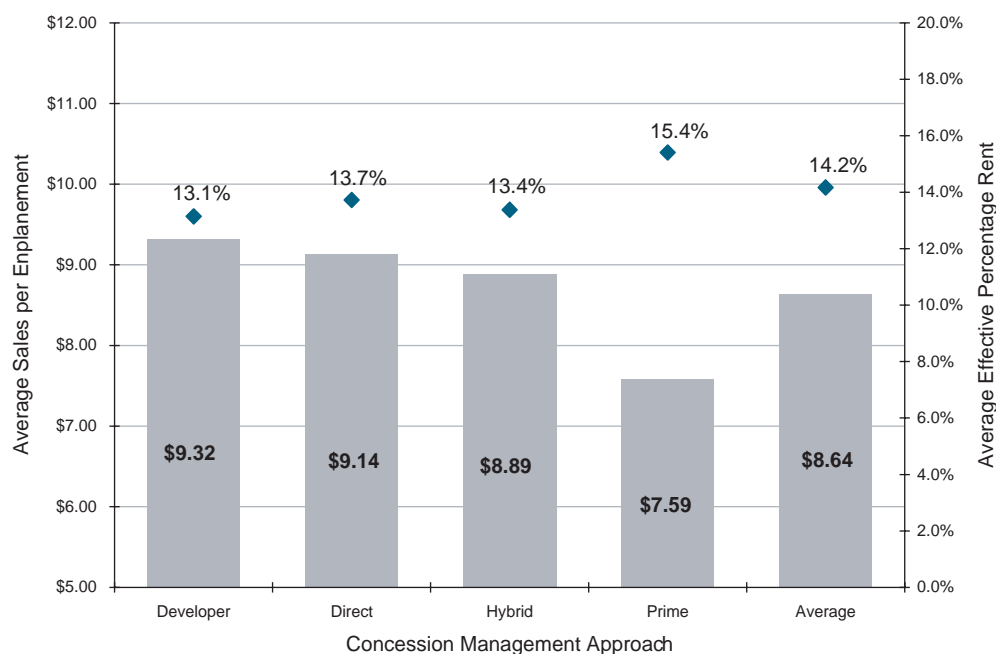

Source: Airport Revenue News 2009.

**Figure 8-1. Comparison of average sales per enplaned passenger and average effective rent by concession management approach (food and beverage and retail)—2008.**



# Business Terms and Concession Agreements

Concession agreements contain the key terms and conditions that establish the business relationship between the airport operator and the concessionaire; the parties will refer to and interpret this agreement throughout its term. Therefore, it is important that the language in the agreement be clear, concise, and comprehensive.

All concession agreements are subject to applicable federal, state, and local laws and regulations. In addition, airport policies and rules must be taken into account and are often specifically referenced in concession agreements.

Airport operators often review the provisions of the concession agreements in place at peer airports to determine industry standards. These standards have wide-ranging acceptance, and their use by airport operators is difficult to challenge successfully. This chapter presents a review of the principal business terms common among all concession agreements:

- Term
- Privileges
- Concession fees
- Obligations
- Performance standards
- Pricing
- Capital improvements
- Midterm investment requirements
- Other concession agreement provisions
- Business practices in need of review

## 9.1 Term

Although survey results show that concession agreement term lengths of 5 years to 10 years are most common, in practice, terms may range from 30-day trials for small retail cart operations to long-term arrangements of more than 10 years (see Figure 9-1). Nearly 50% of the airport operators surveyed for this research have included term extension options of 1 year to 5 years in their agreements to provide flexibility for the airport operator and a performance incentive for the concessionaire, as shown in Figure 9-2. In establishing term lengths, airport operators should consider the following:

- **Expected capital investments.** Larger capital investments may justify longer agreement terms so that adequate time is available to amortize the investments. The term should be long enough for the tenant to amortize its capital investment and receive a reasonable rate of return.
- **The competitive environment.** The expected amount of potential interest in the concession opportunity can be inversely related to the length of the agreement term. If little or no interest



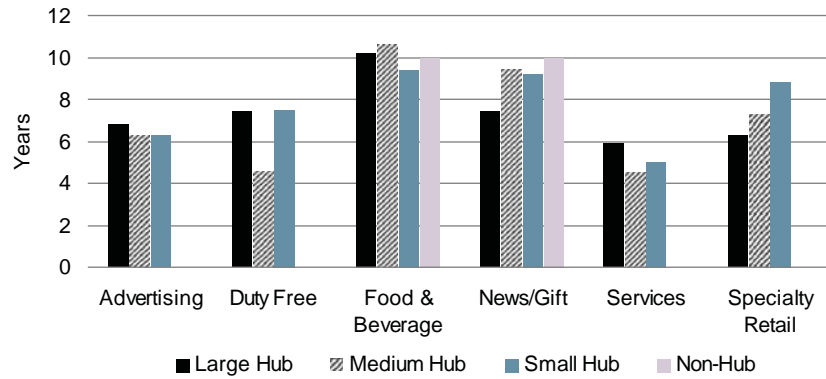

Source: LeighFisher using data from the airport surveys conducted for ACRP Project 01-11.

Figure 9-1. Typical term lengths in concession agreements.

is generated in a potential concession opportunity, a longer term may be needed for the concession opportunity to be viable.

- **The contracting approach.** Term lengths of concession agreements in the Direct Leasing and Prime Concessionaire approach are similar. The term lengths of Third-Party Developer agreements are longer because of the additional front-end hard (construction) and soft (marketing, leasing, and management) costs inherent in Developer agreements.
- **Airport development plans.** New concession locations or anticipated closures of existing locations for terminal redevelopment may justify longer terms to maintain continuity during periods of change, to offer additional periods of time to compensate for additional investment, or to offset sales decreases.
- **Concession concept types.** Customarily, the term lengths for convenience retail agreements are longer than the term lengths for specialty retail agreements because of the narrower margins in newsstand merchandise. Food and beverage agreement terms are longer than retail agreement terms because of the additional equipment required and higher buildout costs.

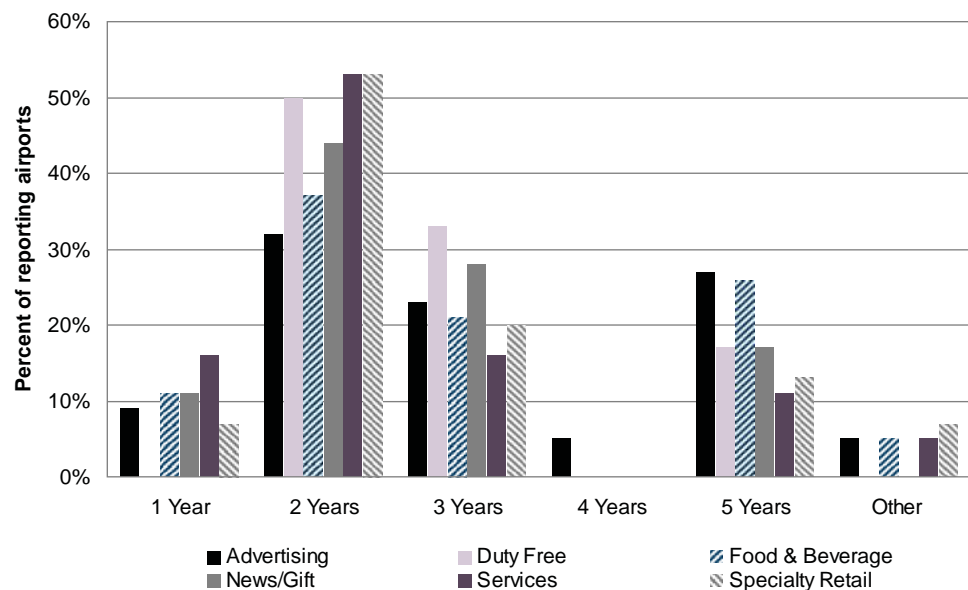

Source: LeighFisher using data from the airport surveys conducted for ACRP Project 01-11.

Figure 9-2. Typical term extension option periods in concession agreements.

- **49 CFR Part 23.** In accordance with Subpart E (“Other Provisions”), Section 23.75 (“Can Recipients Enter into Long-term Exclusive Agreements with Concessionaires?”) of 49 CFR Part 23, *Participation of Disadvantaged Business Enterprises in Airport Concessions, Final Rule and Proposed Rule*, airport operators may not enter into a long-term exclusive agreement for terminal concessions without prior approval of the FAA Regional Civil Rights Office. A “long-term” agreement is defined as one having a term longer than 5 years. An “exclusive” agreement is defined as one in which an entire category of a particular business opportunity is limited to a single business entity. If special local circumstances exist that make it important to enter into a long-term exclusive agreement, airport operators may submit detailed information with requests to the FAA Regional Civil Rights Office for review and approval to enter into such an agreement.

Term extension options should be carefully crafted and managed so that they meet legal requirements, serve the airport operator’s purposes, and are granted only to deserving concessionaires. Some concessionaires will volunteer to refurbish concession units in return for a term extension. These inducements should be carefully reviewed and, in most cases, avoided, as the airport operator is likely to derive greater benefit from a competitive solicitation for the spaces governed by the expiring agreement.

From a concessionaire standpoint, term length is valuable, as it has a direct relationship to the company’s profitability. Unlike other retail businesses where the proprietors own their places of business or have long-term leases and options on the property, airport concessions are operated under agreements that have a fixed expiration date. Term extensions can have a positive effect on company balance sheets, the value of the enterprise, and the share price.



## 9.2 Privileges

Privileges are granted to concessionaires by airport operators in return for concession fees and other payments and for the benefit of having concessions available to airport users. This exchange of something of value for something else of value in contract language is referred to as *consideration* and is necessary for a contract to be enforceable.

Concession agreements list the privileges granted to the concessionaire in return for the consideration the airport operator receives, e.g., rent payments or guarantees on the one hand and concession units selling goods and services to the public on the other hand. These privileges may differ somewhat from airport to airport, but generally include the following:

- Rights to operate a specific concession or concessions. These rights may be exclusive or non-exclusive.
- The right to access and use the airport for business purposes.
- The lease of certain designated space to conduct business.
- The right to make airport-operator-approved improvements to leased areas.
- The right to use certain areas for support purposes (food court seating, delivery corridors, office space, etc.). These areas may be part of the concessionaire’s leasehold (e.g., kitchens, office space, and storage areas) or they may be designated for common use (e.g., food court seating areas and product delivery/waste removal corridors) by multiple concessionaires.
- The types of products that can be sold.
- In some instances, the right to enter into airport-operator-approved subleases with third-party concessionaires.

The manner and extent of the privileges granted to the concessionaire should be clearly stated in the concession agreement to help avoid any future disagreements regarding their interpretation or application.



## 9.3 Concession Fees

Concession fee payments to the airport operator are often based on the greater of a fixed minimum payment (the minimum annual guarantee, or MAG) or a percentage(s) of the concessionaire's gross receipts from sales, as defined in the concession agreement. The concession fee arrangement is a critical component of the financial success or failure of concessionaires. For airports, the MAG provides a source of guaranteed revenues that reduces the potential volatility of revenues in the event of traffic downturns.

### 9.3.1 Minimum Annual Guarantee

The results of the surveys conducted for this research show that, on average, a MAG is included in more than 90% of food and beverage, retail, duty free, and advertising concession agreements. Only the services category (e.g., seated massage, Wi-Fi, shoeshine) reflected a lower rate of MAG use (80% on average). See Figure 9-3.

The MAG can be computed in several ways, but a common rule of thumb is that the MAG should be no lower than the rental value of the space (e.g., the square footage leased to the concessionaires in each space category [retail or concession space, shop space, office space, storage space, etc.] multiplied by the established rental rate for that category of space). Not all airport operators set rental rates for concession space based on square footage.

Some airport operators use a different method to calculate the MAG for a new concession agreement, as the use of a standard or average square-footage-based rental rate calculation often results in a MAG for some spaces that falls substantially below the actual rental rate for the same space. Airport operators setting a MAG based on average revenue per square foot often have to use a lower common denominator (average) to derive a MAG that is appropriate for all spaces, including lower-volume spaces. This approach can result in high-performing, well-located units with MAGs well below market rates. When a MAG based on square footage is used, it is best to combine it with a mechanism to reset the MAG based on performance each year of the agreement.

The Year 1 MAG (which should never be less than the space rent based on square footage) is sometimes computed based on the concession fees received by the airport operator from the space in the most recent year or based on the projected Year 1 percentage fees that the airport operator expects to receive under the new concession agreement. For example, the airport operator

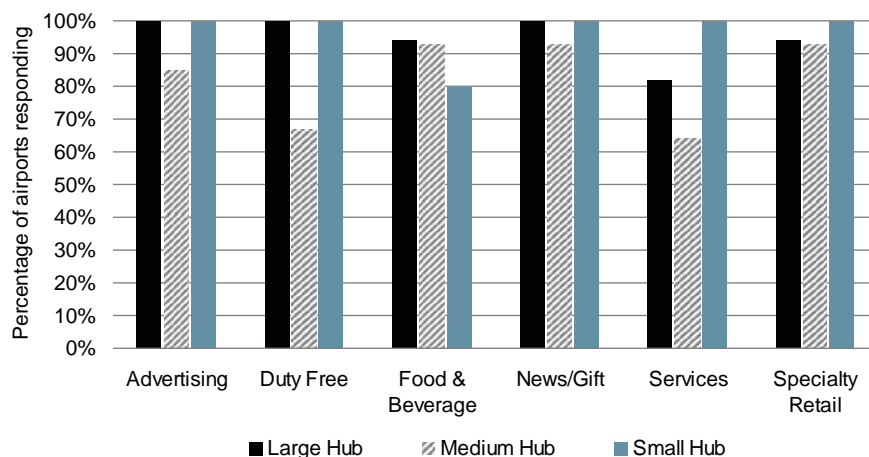

Source: LeighFisher using data from the airport surveys conducted for ACRP Project 01-11.

**Figure 9-3. Use of minimum annual guarantee by category and hub size.**

may set the MAG for Year 1 at 80% of the concession fees it is currently receiving, with the decrease to 80% implemented so that interested firms have a margin to offset the uncertainties associated with a new venture. This approach will usually result in more competition for the concession opportunity.

The MAG for subsequent years is typically adjusted based on some predetermined factor. Some typical adjustment methods in use are as follows:

- Specified MAG amounts are designated for each subsequent year of the concession agreement.
- Annual adjustments are made based on economic factors (typically changes in the Consumer Price Index).
- Demand-driven adjustments are made based on a percentage of the prior year's concession fees (e.g., 85% of the percentage of gross sales concession fees from Year 1 would be set as the MAG for Year 2).
- In the case of the less commonly used enplaned-passenger-based MAGs, adjustments are made based on percentage changes in enplaned passenger traffic.



When developing new concession agreements, airport operators need to determine which MAG adjustment methodology best serves their purposes.

Regardless of the approach used, in most cases, concession agreements establish that the MAG in succeeding years may never fall below the Year 1 MAG amount, which constitutes the floor of the airport enterprise's minimum annual revenue throughout the term of the concession agreement.

Two events in the past decade have heightened the importance of having well-defined MAG provisions in concession agreements. The attacks of September 11, 2001, and the financial crisis and subsequent economic downturn in 2008 caused deep declines in airline travel. Because these events were felt around the world, the downturn in airline travel created financial hardships for many airlines and concessionaires. Events such as these spurred some concessionaires to request financial relief (e.g., lowering or eliminating their MAG) even though no clause was contained in their concession agreements allowing for such relief. Most airport operators declined this request because of the concern that it would establish an undesirable precedent and because airport operators also faced similar declines in passengers and passenger-related revenues.

An outcome of the systemic shock following the attacks of September 11, 2001, was that financial relief clauses were introduced in concession agreements at a few airports, whereby the MAG was to be reduced in proportion to certain significant decreases (say, 20% or more) in enplaned passengers compared with the number of passengers in the same month(s) of the prior year. Typically, when such financial relief clauses are included, the financial relief continues until enplaned passenger traffic resumes to a stipulated level (e.g., recovery of traffic above the 20% reduction threshold).



The MAG is a traditional component of all commercial leases, including those at airports, and serves several purposes:

- The MAG provides a guaranteed source of income to the airport operator, which can help support the airport enterprise's financial needs and strengthen its credit rating.
- The MAG serves as an incentive to ensure that the concessionaire is committed to and diligent in its operations and motivated to reach certain sales targets.
- The MAG corresponds to a minimum sales threshold and thus discourages bidders that would not expect to achieve a sufficient level of sales.

Bidding MAGs may have the effect of producing unsustainable MAGs that can lead to undesired outcomes such as high prices, poor service, attempts to renegotiate payment terms, or, in extreme

**Table 9-1. Sample MAG versus percentage of gross receipts reconciliation.**

	Monthly MAG (A)	Monthly % of Gross (B)	Amount Paid (C) (Greater of A or B)	Under (Over) Payment (Greater of A or B minus C)
January	\$50,000	\$57,000	\$57,000	
February	\$50,000	\$41,000	\$50,000	
March	\$50,000	\$43,000	\$50,000	
April	\$50,000	\$42,000	\$50,000	
May	\$50,000	\$55,000	\$55,000	
June	\$50,000	\$50,000	\$50,000	
July	\$50,000	\$53,000	\$53,000	
August	\$50,000	\$47,000	\$50,000	
September	\$50,000	\$49,000	\$50,000	
October	\$50,000	\$51,000	\$51,000	
November	\$50,000	\$54,000	\$54,000	
December	\$50,000	\$49,000	\$50,000	
<b>Totals</b>	<b>\$600,000</b>	<b>\$591,000</b>	<b>\$620,000</b>	<b>(\$20,000)</b>

cases, concessionaire failures. The evaluation of financial elements of the competitive selection process is discussed in Section 10.6.

Historically, the MAG has been prorated on a monthly basis, and payment to the airport operator is due by the first day of each month. A sales report is subsequently filed within a certain number of days following each month, and if the percentage of gross receipts payment due exceeds the prorated MAG paid for the same month, then the concessionaire owes an additional concession fee payment. At the end of each year, the numbers are reconciled; the percentage of gross receipts concession fee is compared to the MAG, and any additional amounts due are paid and any overpayments are refunded. This method thus takes seasonal variations in sales into account and may result in the issuance of refunds. Table 9-1 shows the calculation of a hypothetical MAG adjustment.



Some airport operators charge a minimum monthly guarantee (MMG) rather than a MAG. Under this approach, the MMG is compared to the percentage of gross receipts payment due each month on a stand-alone basis. This approach provides the airport operator with a monthly revenue source that can be accurately recorded and eliminates the need for annual reconciliations and credits or refunds. However, the MMG is not yet widely used in the industry and may create hardships for concessionaires because seasonal variations in sales may result in a higher effective percentage rent over the course of a year. Therefore, it is possible that a tenant could pay an effective percentage rate for an entire year that is higher than the nominal percentage rent set forth in the concession agreement, and the difference could be material, particularly in cases where the percentage rent is already high. Airport operators should carefully consider the pros and cons of this approach and the monthly variation in historical enplaned passengers before adopting this approach.

### 9.3.2 Percentage Rents

The survey results indicate that percentage rents for the major concession categories typically average in the 10% to 15% of gross receipts range, except for terminal advertising (which is usually considerably higher) and duty free (which is often somewhat higher). Although, in some cases, the concession fee may be based strictly on the percentage of gross receipts, it is far more common that a minimum guarantee payment is established as well (see preceding MAG discussion) and that concession fee payments are determined based on the MAG (or MMG) or the percentage(s) of gross receipts, whichever is greater.





In the case of Third-Party Developer agreements, rent payments by the concessionaires to the Developer are typically based on the greater of a MAG (or MMG) or percentage(s) of gross receipts, as established in the Developer's negotiations with each subtenant. The Developer's payments to the airport operator are based on the greater of a MAG (or MMG) or percentage of rents collected from subtenant concessionaires.

The percentage(s) of gross receipts (or rent in the case of a Third-Party Developer) concession fee may be set by the airport operator or it may be established through the proposal as a component of the financial offer in the tenant selection process. In their solicitations, airport operators generally require that financial offers (e.g., MAG and/or percentage of gross receipts) and technical information be submitted as part of proposal packages for concession opportunities. The surveys conducted for this research show that the financial offer is often the most heavily weighed criterion in the selection process.

Some airport operators choose to set concession fee percentages rather than asking for proposals to eliminate the bidders' ability to "buy the concession agreement" by offering unrealistically high percentage payments, which can lead to the failure of the concessionaires or a reduced quality of service and product. Under this approach, the airport operator sets the percentage based on industry standards or a pro forma analysis of the potential of the concession spaces. Setting the percentage allows the airport operator to focus more on the technical capabilities of competing concessionaires than on the size of the percentage rent offered when evaluating proposals. The downside, however, of this approach is that it may limit the airport operator's concession fees. Airport operators need to carefully consider their goals and objectives and the associated risks in determining which approach is best.

Average percentage rents reported in the surveys conducted for this research are shown in Figure 9-4. A brief discussion of the results in each category follows:

- **Food and Beverage.** Average concession fee percentages of 13% and 14% were most common among medium hub and large hub airports, respectively, but the percentages reported ranged from as low as 8% to as high as 20%. The operators of small hub airports typically establish concession fees that are somewhat lower on average (10% to 13%). Percentage rents may also be set by concept, with casual dining units at the low end of the range and bars (or alcoholic beverages) at the high end of the range.

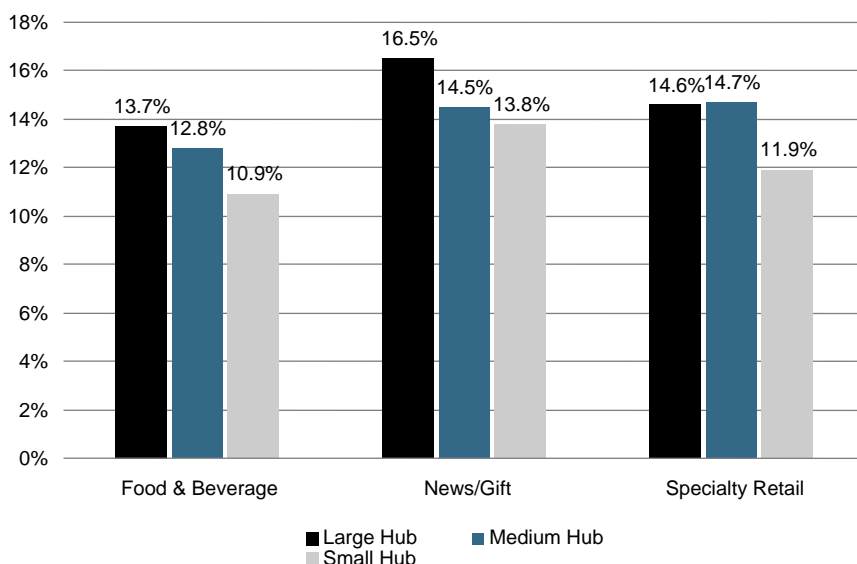

Source: LeighFisher using data from the airport surveys conducted for ACRP Project 01-11.

**Figure 9-4.** Average percentage rent by category and airport size.

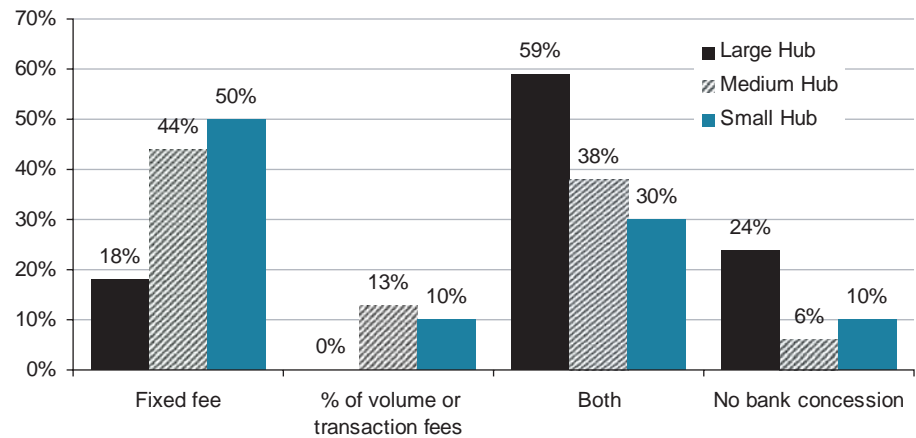

Source: LeighFisher using data from the airport surveys conducted for ACRP Project 01-11.

**Figure 9-5. Type of revenues from banking and foreign exchange services by category.**

- **Convenience Retail.** Average concession fee percentages reported in the survey ranged from 9% to 22%. The most common concession fee percentage reported was 15%.
- **Specialty Retail.** Approximately 75% of the airport operators that responded to the survey reported average concession fee percentages in the 12% to 16% range. As with convenience retail, 15% was the most often reported concession fee percentage.
- **Duty Free.** 42% of the respondents reported that they do not charge a percentage rent for duty free operations. These were all medium or small hubs; 8 out of 13 medium hubs and 3 out of 4 small hubs indicated that they had a fixed fee for duty free. No large hubs had fixed fees. Airports charging a percentage rent reported percentages ranging from a low of 10% to a high of 30%, with 20% being the most common.
- **Advertising.** Percentage rents in the advertising category ranged widely, from 0% to 85%. Nearly half of the airport operators reported advertising concession fees in the 60% to 70% range.

The surveys conducted for this research also showed that the MAG (fixed fee) versus percentage fee (based on transaction volume or transaction fees) approach is most commonly used at those airports with banking service (including ATMs) and foreign currency exchange concessions. The survey results for this category are shown in Figure 9-5.

### 9.3.3 Other Concession Fee Approaches

Other concession fee approaches may include, but are not limited to, profit-sharing, per enplaned passenger fees, or some combination thereof.



With the profit-sharing approach, a formula is established whereby an amount of net revenue, after certain defined expenses and fees are deducted, is shared with the airport operator. Profit-sharing may increase the amount of revenue paid by the concessionaire to the airport operator and further solidify the two parties as partners. However, consistent receipt of revenue from profit-sharing cannot be counted on, as such revenues are subject to sales and expense fluctuations, allocation methodologies, and auditing challenges that may greatly reduce or eliminate profit-sharing payments to the airport operator. As such, care needs to be taken before reducing the amount of otherwise achievable concession revenues in favor of less certain profit-sharing revenues. Profit-sharing arrangements may provide marginally improved revenues, but may also transfer risk to the airport operator when passenger traffic declines or concessionaire costs increase.

Fees based on numbers of enplaned passengers are sometimes established as a way to link concession MAGs with passenger numbers. Under this approach, the airport operator establishes a fixed fee to be paid by concessionaires for each enplaning passenger at the airport. This approach has advantages for the concessionaire, as the MAG is set in proportion to the business opportunity, and for the airport operator, in that the MAG can increase as passenger activity increases. At the same time, if passenger activity declines, so would the MAG. Care needs to be exercised in setting the per-passenger fee if this approach is used, as several factors can reduce the numbers of passengers exposed to a concession location, including the economy, construction plans, gate relocations or closures, airline relocations, and other factors.



### 9.3.4 Additional Fees and Charges

Payments for support space (e.g., offices and storage areas) rentals, common area maintenance (CAM), marketing fund contributions, storage and delivery fees, utility use, employee parking, employee badging, and other items may also be required. These fees and charges are discussed below:

- **Rent for Support Space.** This cost may be included in the concession fee calculation or may be separately charged. If support space is provided at no additional cost, airport operators must be careful that concessionaires do not occupy more free support space than they reasonably need to operate their concessions.
- **CAM Fees.** These fees are often paid by concessionaires as reimbursement for the expense of services provided by the airport operator (or the Third-Party Developer) in common or shared areas, e.g., food courts. CAM fees may cover maintenance, janitorial, utilities, replacement of expendable items such as trays or trash containers, signage, and other common-area costs. Specific costs to be covered by CAM fees should be spelled out in detail, along with the methodology for apportioning costs among tenants on a fixed basis, variable basis, or combination of the two.
- **Marketing Fund Contributions.** The airport operator (or Third-Party Developer) may establish a fund for marketing the concessions, which is supported by required contributions (often determined based on a fixed percentage of sales) from the concessionaires. Periodic accountings of moneys spent and defined purposes for which moneys can be used should be established. Some airports make contributions to the marketing fund.
- **Storage and Delivery Fees.** A warehousing and delivery program may be established whereby products are received for subtenants at a centralized location and delivered to concession units for a fee.
- **Utility Charges.** Airport operators may or may not require concessionaires to pay separate charges for the use of utilities. When required, separate meters may be installed so that the utility companies bill the concessionaires directly, or charges may be determined based on allocations from submeter readings or estimated use calculations.
- **Employee Parking.** Typically, the airport operator only provides free parking for a minimal number of the concessionaire's management personnel.
- **Employee Badging.** The concessionaire may be obligated to pay fees for employee badging. The concessionaires may or may not elect to pay airport employee badging charges for their employees.



## 9.4 Obligations

Similar to all contracts, concession agreements create the obligations of the parties. While not all potential issues can be foreseen, clearly defining each party's obligations under the agreement helps avoid or minimize responsibility uncertainties and associated disputes throughout the term of the agreement.



A partial listing of obligations typically included in concession agreements is provided below:



- **Rents and fees.** At a minimum, the concession agreement should state the rents and fees that the concessionaire must pay; how and when rents and fees are determined and adjusted; the definition of gross receipts for purposes of computing percentage fees due; how any CAM, marketing, and other use fees will be charged; and whether a mechanism exists for adjusting the MAG (or MMG).



- **Reports and payments.** At a minimum, the concession agreement should state when reports and payments are due, the format of the reports and what information should be included, whether any reports need to be prepared by a Certified Public Accountant (CPA), the penalties for not filing reports or not making payments on time, and when annual reconciliations of the MAG versus the percentage of gross receipts concession fee need to be performed and by whom.



- **Auditing.** The agreement should list airport operator rights with regard to auditing the books and records of the concessionaire. The agreement should state whether the rights are limited to auditing gross receipts or whether more comprehensive audit reviews are allowed, indicate whether the airport operator can hire outside third parties to conduct audits and how often audits can be conducted, indicate where books and records are to be maintained for audit purposes, and indicate who pays for the audit (especially if travel to audit the records is involved). Finally, the agreement should indicate whether there will be any consequences if audit results show significant errors.



- **Maintenance and janitorial.** The concession agreement should detail the maintenance and janitorial responsibilities of the airport operator and the concessionaires. A responsibility matrix for such purposes should be included in the concession agreement. Maintenance responsibilities are one of the most common questions that arise during the life of the concession agreement. A responsibility matrix provides a convenient and straightforward means of delineating responsibility between the airport operator and the concession tenant that can be quickly referenced. Table 9-2 presents a maintenance responsibility matrix used at Sacramento International Airport.



- **Installation and payment of utilities.** The concession agreement should clearly indicate the responsibilities of the airport operator and the concessionaire regarding the installation of and payment for utilities. For example, the airport operator may bring utilities (electricity, gas, water, and sewer) to the perimeter of the leased premises and the concessionaire may be responsible for the necessary connections. Concession contractors are typically responsible for changes to existing utility systems, subject to the approval of the airport operator. As noted earlier, airport operators have different approaches to utility cost recovery, and may or may not pass these costs on to the concessionaires.



- **Capital improvements.** The concession agreement should detail the process and requirements for the construction of capital improvements, including the following:
  - capital improvement plans, including any design submittal requirements;
  - permitting requirements;
  - the required development schedule;
  - minimum capital investment, annual refurbishment, and midterm renovation requirements;
  - construction contracting requirements;
  - the schedule and documentation required for submittal of final project costs;
  - whether the concessionaire or the airport operator will hold title to the improvements;
  - buyout provisions;
  - financial penalties, such as liquidated damages, for failure to complete the project on time; and
  - any requirements for removal of improvements and restoration of property upon agreement expiration or termination.

**Table 9-2. Sample preventive/corrective maintenance responsibility matrix (Sacramento International Airport).**

#	Equipment	County Responsibility	Concessionaire Responsibility	Not Applicable
<b>Electrical</b>				
1	Infrastructure (within Leased Premises or exclusively serving Leased Premises)		X	
2	Transformer - Concessionaire Electrical Service	X		
3	Transformer(s) - other than main service		X	
4	Panels		X	
5	Time Clocks		X	
6	Receptacles		X	
7	Switches		X	
8	UPS Systems (within Leased Premises or exclusively serving Leased Premises)		X	
9	Testing		X	
10	Repair		X	
11	Maintenance		X	
12	Lighting - Interior within the Leased Premises		X	
13	Lamps		X	
14	Ballasts		X	
15	Fixtures		X	
16	Common area lighting - Exterior Lighting Located in common areas of the Airport	X		
17	Lamps	X		
18	Ballasts	X		
19	Fixtures	X		
20	Tenant area lighting - Lighting located in common areas illuminating Leased Premises		X	
21	Lamps		X	
22	Ballasts		X	
23	Fixtures		X	
24	Signage - lighted		X	
25	Lamps		X	
26	Ballasts		X	
27	Fixtures		X	
28	Aircraft Ramp lighting			X
29	Hangar lights			X
<b>Plumbing</b>				
30	Infrastructure			X
31	P-Traps			X
32	Trap primers			X
33	Sewer Lines			X
34	Water Pipe			X
35	Vents			X
36	Floor sinks			X
37	Toilets			X
38	Grease Traps			X
39	Mop sinks			X
40	Waste drains			X
41	Backflow preventers			X
<b>Fire Suppression System</b>				
42	Fire Alarm Detection (including 24-hour monitoring)	X		
43	Fire Suppression System (Building Wide System)	X		
44	Fire Suppression Equipment Exclusive to the Leased Premises (i.e. Fire Extinguisher, etc.)		X	
<b>Building Interior</b>				
45	Signage - non-lighted		X	
46	Wall finishes (including store front)		X	
47	Cabinetry - repair		X	
48	Cabinetry - new		X	
49	Doors (including locks, hinges and closers)		X	
50	Interior leased space doors		X	
51	County space/leased space doors		X	
52	Fire doors		X	
53	Roll up Doors		X	
54	Bag belt Systems			X
55	Restrooms fixtures (towel/soap dispensers, mirrors, partitions, etc.)			X
56	Floor Tiles/Carpet		X	
57	Ceiling (tiles and grid)		X	
58	Display cases (within Leased Premises)		X	
59	Art work (within Leased Premises)		X	
<b>Building Exterior</b>				
60	Pavement	X		
61	Repair and Patch Roof	X		
62	Clean and Clear Gutters	X		
63	Structural Maintenance and/or repairs	X		
64	Exterior Walls, Roof and Foundation	X		
65	Landscaping	X		
<b>HVAC</b>				
66	UPS System HVAC (common to building HVAC)	X		
67	UPS System HVAC (leased space HVAC)		X	
68	Kitchen ventilation systems			X
69	Exhaust Fans			X
70	Common to building HVAC	X		
71	Ceiling Vents		X	
72	Thermostats		X	
73	Leased space HVAC		X	
<b>Miscellaneous</b>				
74	Pest Control (as necessary to maintain a pest and vermin free condition)		X	
75	Equipment and Improvements installed by Tenant (whether authorization was given or not)		X	
76	Janitorial		X	
77	Trash Removal		X	
78	Power Monitoring and Control System (PMCS)	X		

Additionally, any improvements to be provided by the airport operator should be described, along with their schedule for completion if they do not already exist. A Tenant Design Manual should be included with the solicitation document and incorporated into the completed concession agreement. (Capital improvements are discussed in depth in Chapter 12).



- **Insurance and bonding.** Insurance requirements for the concessionaire and its subtenants and contractors should be clearly stated in the concession agreement. Likewise, any requirements for construction-related bonds, payment guarantee bonds, and performance bonds should also be described. It is important to specifically indicate the types of guarantee instruments that may be submitted to meet the bond requirements.
- **Indemnification.** Indemnification language is typically included in concession agreements, as specified by the airport operator's legal counsel.
- **Security.** Language should be included in concession agreements requiring concessionaires, their subtenants, and their contractors to comply with all of the security rules and regulations in force at the airport. The concessionaires should be responsible for paying any fines imposed on the airport operator resulting from security violations by the concessionaire, its subtenants, contractors, or any other associated parties.
- **Other obligations.** Damage or destruction of premises, environmental cleanup, employee badges, employee parking, prohibition of liens, and taxes are some of the other provisions typically included in concession agreements.

## 9.5 Performance Standards



A well-written concession agreement will specify the performance standards with which concessionaires are expected to comply. An understanding of the required performance standards will assist concessionaires in projecting expenses and determining the concession fees they can afford to pay. Additionally, clearly stated performance standards reduce the potential for disagreements between the airport operator and concessionaire during the term of the agreement. Performance standards also play an important role in the concession unit's physical appearance and the quality of customer service.

Failure to monitor and enforce compliance with performance standards on a regular and consistent basis can easily lead to a deterioration of customer service and a culture of bad habits that may be difficult to correct.

Performance standards often cover hours of operation, requirements for responding to customer complaints, minimum management qualifications, dress code, staff training, signs, merchandising, cleanliness of facilities, and recycling (see Table 9-3). Airport operators should tailor the performance standards in their concession agreements to the policies, procedures, goals, and objectives in place at their particular airport.



Some airport operators include financial sanctions, fines, or other financial penalties in their concession agreements as a disincentive for concessionaires to fail to meet performance standards and to compensate for lost revenues that may result from such failure. The terminology used—fines, sanctions, administrative penalties, or other terms—will vary depending on state and local laws. This approach, where feasible, can be helpful to concession managers. Airport concession managers may have no mechanism to alert a concessionaire that is failing to meet performance standards except to issue a formal notice of default of the terms of the concession agreement, which is a serious action that may be disproportionate to the performance problem. Financial sanctions or fines should not be viewed as a substitute for maintaining effective communications with the concessionaire's representatives. Misuse of fines or sanctions can create an adversarial relationship that is not in the best interests of either party.



**Table 9-3. Sample list of financial sanctions in a concession agreement (Sacramento International Airport).**

Section A Violations:	Occurrence	Amount of Sanction
Hours of Operation	1	Written Notification
Operations, Service Standards and Employee Standards	2	\$200 Sanction
Pricing	3	\$400 Sanction
Quality	4	\$750 Sanction
Signage	5	\$1,000 per occurrence thereafter or default under Section 3.23 of the Agreement
Interference with Utilities		
Deliveries and Vendor Access		
Section B Violations:	Occurrence	Amount of Sanction
Maintenance and Repairs	1	\$250 Sanction
Sanitation	2	\$500 Sanction
Hygiene and Cleanliness	3	\$1,000 per occurrence thereafter or default under Section 3.23 of the Agreement
Waste Disposal, Grease Disposal Recycling		
Health Code Violations		

Even a small fine will get the attention of the local concession manager and, in particular, corporate management, and can be helpful in communicating the airport operator's dissatisfaction with the concessionaire's performance, if necessary.

## 9.6 Pricing

For many years, the typical policy regarding airport concessions was simply that concessionaires had to submit the prices they intended to charge their customers to the airport operator for a review of reasonableness and subsequent approval. "Reasonable" pricing in that context was not generally well defined.

A movement to a structure based on street pricing later emerged and has been adopted at many of today's airports. At some airports, the concession agreement requires a strict compliance with street pricing, while, at others, an add-on, such as street pricing plus 10%, is in place. The surveys conducted for this research indicated that street pricing plus 10% is now the most commonly used pricing policy among airport concessions (except for duty free where prices are most often benchmarked to those at other airports); straight street pricing with no markup was a close second. Between 41% and 46% of the airport operators surveyed indicated the use of street pricing plus 10% for their food and beverage, convenience retail, and specialty retail concessions, while between 33% and 38% indicated that they use street pricing with no markup. Other than duty free, only 5% of the airport operators reported having no pricing policy. Airport pricing policies identified in the surveys conducted for this research are summarized in Figure 9-6.

The pricing policy is usually stated in the concession agreement, but, in some cases, the pricing policy document may be referenced but not included. Pricing policies need to be clearly



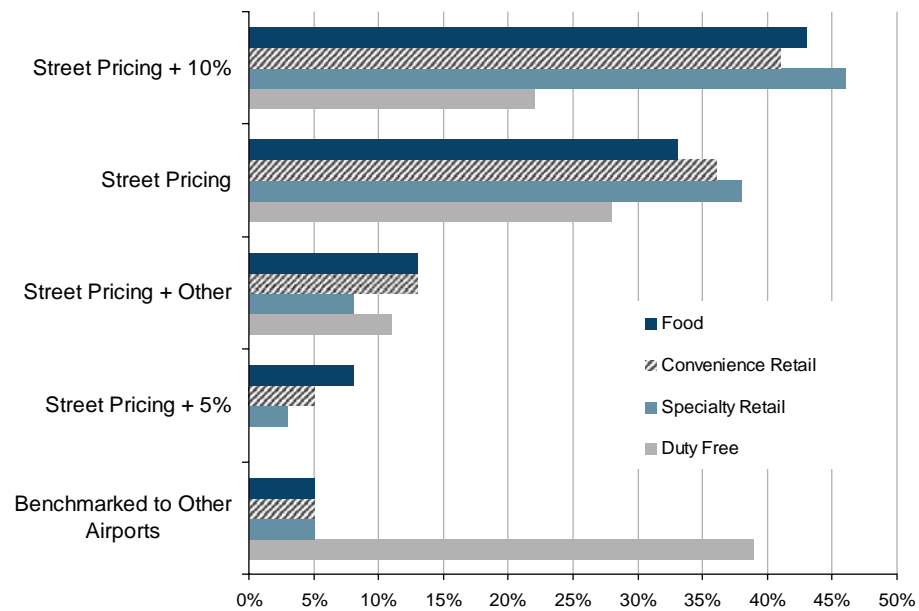

Source: LeighFisher using data from the airport surveys conducted for ACRP Project 01-11.

**Figure 9-6. Airport pricing policy at surveyed airports by hub size.**

written and made available during solicitations, as potential concessionaires need to understand the pricing policy since it will influence their pro forma revenue and expense projections and their financial offers.

Many in the industry believe that street pricing yields more transactions and higher sales volumes, but there is little empirical evidence to support this belief. However, concession developers are adamant that street pricing has a positive effect on both sales and customer satisfaction. Survey respondents indicated that they generally believed that pricing limits resulted in higher overall sales, but they also could not cite empirical evidence to support this belief. In interviews with concession managers, several noted that complaints were received about concession prices even where true street pricing is in effect.



Enforcing pricing policies and, in particular, conducting price comparisons to support enforcement, can be difficult and time consuming. Comparisons of prices for branded concessions with off-airport equivalents are straightforward and easiest to conduct. For generic concepts, or those with no other branded concepts in the region, care must be taken to identify reasonable comparables. The selection of comparables has often been a source of disagreement. Clear definitions of comparables in the concession agreement help to reduce such disagreements.

While pricing is important to customers, it is just one element of the value proposition of the concession program. Several concession managers noted that the location, surroundings, types of products, customer service, portion size, and other factors also weigh heavily in the customers' perceptions of their shopping experience at the airport and influence the amount of sales generated.



In interviews with several concessionaires, it was noted that street pricing policies may not be realistic given the high cost structure at many airports, particularly large hub airports where wage rates, delivery costs, and other operating costs are high. The concessionaires also noted that the difference between true street pricing, for example, and street pricing plus 10% can make a difference between profit and loss. Concessionaires generally believed that pricing policies need to reflect the sales volume and cost structure of the airport's concessionaires and take into account percentage rents, development costs, local wage rates, and other costs.

## 9.7 Capital Improvements

Airport operators most often provide unfinished space (e.g., concrete floors, demising studs and walls, and utility connections) for new concession locations. Existing space is either provided in as-is condition for renovation or delivered by the airport operator in a shell and core condition. In the case of common or shared areas (e.g., food courts serving multiple concession operators), the airport operator must decide in advance of issuing its solicitation documents whether it will take responsibility for the buildout and upkeep or make buildout and upkeep a requirement of one or more concessionaires.

The concession agreement should indicate the condition in which each leasehold space will be provided. It is good practice to include Tenant Design Criteria in the concession solicitation documents to enable the concessionaires to better plan and estimate more accurately the costs of construction and to avoid later disagreements with the airport operator over designs and construction plans.



Capital investments vary greatly based on the level of finishes, prevailing wage rates, unit design, airport operator requirements, market conditions, and other factors. At many airports, the design review and permitting process can be cumbersome and slow moving, which may also add to the cost. (Capital costs for concessions are discussed in Chapter 12.) Airport operators should periodically review the effects of such process costs on concessionaires and consider whether such processes can be streamlined to reduce costs without sacrificing safety or quality.

Concession agreements and RFPs more often than not include minimum investment requirements and midterm refurbishment expenditure requirements. Minimum investment requirements indicate to proposers that the airport operator expects a certain standard/quality of buildout and establish a commitment from the concessionaires to spend at least a target amount on their capital improvements. Further, including minimum investment requirements avoids the potential for some proposers to increase their financial offer in an attempt to win the concession while reducing the investment in the concession space by minimizing the capital investment and substituting a cheaper level of finishes and fixtures in the buildout. In establishing minimum investment requirements, airport concession managers should be aware of any recent costs for building concession facilities at their airport, as well as at other airports. As the result of security requirements, delivery restrictions, materials durability and quality requirements, and other cost factors, concession buildout costs at airports are often significantly higher than at similar branded off-airport locations. Use of a realistic minimum capital investment requirement will force all potential proposers to consider the actual capital costs they are likely to incur and will help avoid later disputes.



Concession agreements should contain requirements for capital investment cost information on completed projects to be submitted to the airport commercial management staff within 90 days of project completion. This information should be reviewed by airport concession staff, and any questions or incomplete information should be promptly addressed. This information can be used to confirm that minimum investment requirements have been met and, should the need arise, as the basis for any later buyout that may become necessary.



It is standard practice for the concessionaire to pay the airport operator the difference between its financial investment commitment and any shortfall. Approval of the design and construction drawings does not necessarily guarantee that cost cutting will not occur during construction; the requirement to pay any shortfall to the airport operator serves as a major disincentive to substitute inferior finishes, fixtures, signage, and equipment and helps achieve the high quality of buildouts that airport operators typically desire.



Many airport operators include a provision in their concession agreements allowing for the buyout of capital improvements if a concession location must be reclaimed or reduced in size



for “airport development purposes” such as modifications or expansions of the terminal building. The basis for the buyout is usually straight-line depreciation over the lease term based on the documented capital investments made by the concessionaire and approved by the airport operator. The buyout provisions in concession agreements typically favor the airport operator.



Deadlines for completion of capital improvements should be established in the concession agreement. Failure to complete concession improvements on time can, in fact, cause a terminal or concourse to operate with inadequate concession facilities or even result in the delay of a new terminal or concourse opening. Financial penalties, such as liquidated damages, should be imposed on concessionaires for failure to complete the work needed for concession facilities to open on schedule.

Historically, when the economy was strong and passenger traffic was growing rapidly, some concessionaires would propose on a space expecting that their return on investment would be low in the early years, but that the low return would be offset by higher returns in later years. The attacks of September 11, 2001, and the 2008 financial crisis demonstrate that this offset should no longer be taken for granted.

## 9.8 Midterm Investment Requirements



It is standard practice for airport operators to include a requirement for concessionaires to make additional investments near the midpoint of the agreement term, especially in those cases where the term spans more than 5 years.

The midterm investment requirement is established by the airport operator in the solicitation process and included in the concession agreement. The purpose of the midterm reinvestment requirement is to provide for the renewal and replacement of worn surfaces, furnishings, fixtures, and equipment in the concession facilities. The midterm investment requirement is not recommended as a substitute for ordinary maintenance or as a funding source for deferred maintenance.



Nevertheless, at many airports, the midterm investment requirement has sometimes been used, by agreement, for other purposes, such as the reconcepting of underperforming units, expansions of concession facilities, or upgrades to infrastructure, as allowed by the airport operator. The use of the midterm investment funds is often a matter of negotiation between the concessionaire and the airport operator.

Nearly 80% of airport operators responding to the surveys conducted for this research indicated that they include a midterm investment requirement in their concession agreements. However, there appears to be no standard practice or consensus for determining the midterm investment requirement. Surveyed airport operators identified several methods for establishing midterm investment requirements, including the following:



- A fixed dollar amount per square foot (\$50, \$75, \$100, etc.)
- A negotiated amount
- A percentage of the concessionaire’s original capital investment (e.g., 15%, 20%, or 25%)
- A percentage of the concessionaire’s sales (e.g., 5%)
- The amount submitted as part of the concessionaire’s proposal

## 9.9 Other Concession Agreement Provisions

Many other business terms appear in concession agreements in addition to those identified above. Many terms are similar in purpose from one airport to another, but are worded somewhat differently as part of the boilerplate provisions each airport operator develops for its agree-

ments. Additionally, ACDBE participation goals are set forth in concession agreements (see Chapter 7). Certain airport operators include concession employee-related clauses, such as labor peace, living wage, and worker retention.

When survey respondents were asked if they include unique, innovative, or unusual provisions in their concession agreements, the operators of only a few airports responded affirmatively. The provisions cited included the following:

- **Assignment and sublease clauses.** Airport operators may establish requirements for approval of assignment of the concession agreement including criteria for their approval and fees for the review and approval of assignments, subleases, novation, and other legal transactions brought forward by the concessionaire. Many airports have strong sublease and assignment clauses to discourage sales of a concession agreement. Similarly, most airports will include in concession agreements an outright prohibition on subletting unless it is contemplated in the concession management approach, such as a prime concession agreement with subleasing obligations.
- **MAG reconciliations at contract year end.** Airport operators may base their annual MAG adjustment on data available a few months prior to the MAG adjustment date to avoid the need for retroactive adjustments once data become available (e.g., they may base a July MAG adjustment on March data).
- **Higher rent for airport-operator-built concession units.** Airport operators may build out a concession location to receive a higher MAG or concession fee from concessionaires or to limit the need for longer agreement terms. The operator of Denver International Airport, for example, developed a multi-unit concession to serve the arrivals and meeter and greeter market, which was earmarked for small business enterprises.
- **Key money.** Airport operators may require an upfront cash payment (essentially prepaid rent) as a condition of award.
- **Supplemental rent after depreciation period ends.** Some airport operators, including the operator of Los Angeles International Airport, require concessionaires to pay additional percentage rent if the agreement term is extended. The original investment is assumed to have been amortized over the original term of the agreement.



## 9.10 Business Practices in Need of Review

In the surveys conducted for this research, airport concession managers were asked to identify general business practices that are most in need of change or improvement. The top three practices cited were (1) lack of transparency in the solicitation process, (2) percentage rents, and (3) length of the term. The concessionaires surveyed had different views; the top three business practices that concessionaires thought airport operators should consider changing were (1) MAG requirements, (2) the costs of constructing improvements, and (3) the length of the agreement term. Figure 9-7 shows the relative importance of the issues mentioned by both airport operators and concessionaire representatives.

## 9.11 Additional Concession Agreement Resources

The ACI-NA Commercial Management Committee maintains a resource center for members that includes RFPs and concession agreements from a number of airports. It is located at <http://www.aci-na.org/content/commercial-management-committee>.

*ACRP Report 33: Guidebook for Developing and Managing Airport Contracts* is a guidebook of best practices for developing, soliciting, and managing airport agreements and contracts for use by a variety of airports (Vanden Oever et al. 2011). The agreements covered in *ACRP Report 33*

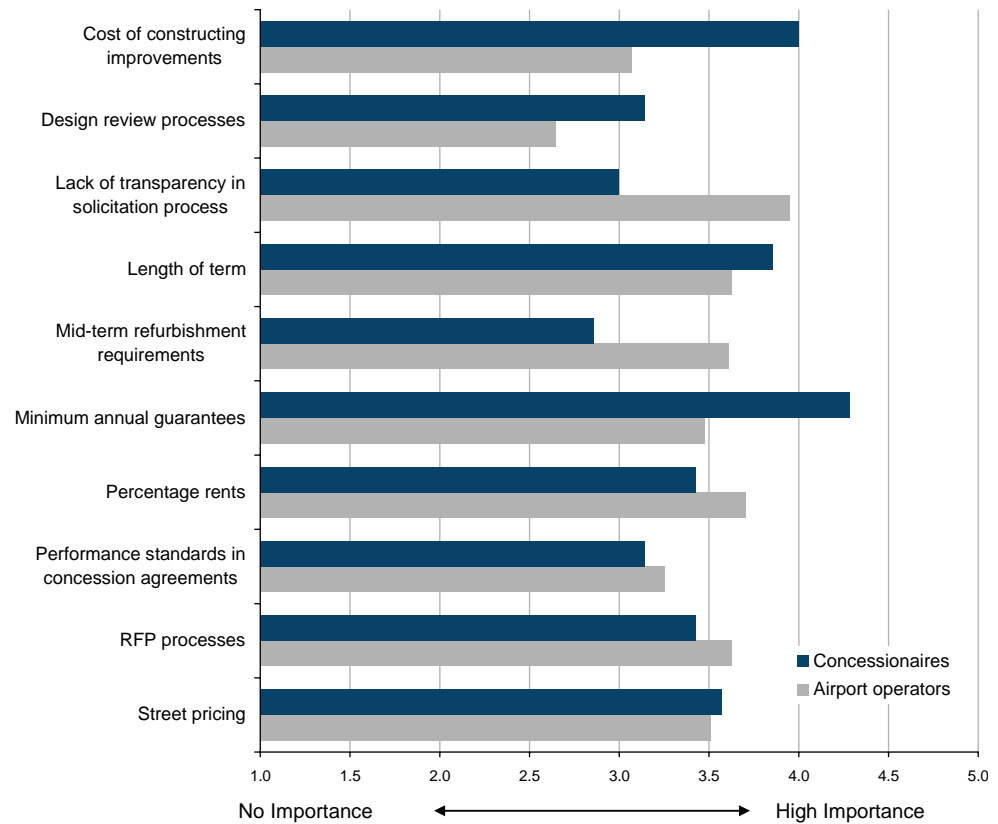

Source: LeighFisher using data from the airport surveys conducted for ACRP Project 01-11.

**Figure 9-7. Airport concession industry business practices in need of improvement.**

include, among other types, in-terminal concession agreements. An accompanying CD-ROM provides sample agreements. The CD-ROM included as part of *ACRP Report 33* is also available for download from the Transportation Research Board's website as an ISO image. The report and sample agreements may be downloaded at [http://www.trb.org/Publications/Blurbs/Guidebook\\_for\\_Developing\\_and\\_Managing\\_Airport\\_Cont\\_164803.aspx](http://www.trb.org/Publications/Blurbs/Guidebook_for_Developing_and_Managing_Airport_Cont_164803.aspx).



# Procurement

This chapter presents approaches, practices, and strategies for soliciting and selecting concessionaires. Once the concession plan is prepared and the program is ready for implementation, selecting the best tenants may be the single most important responsibility of the concession manager. Following sound procurement practices can also help avoid protests and challenges to the procurement process.

This chapter covers the following:

- Concession procurement approaches
- Requests for proposals—the standard practice
- Minimum qualifications
- Typical elements required in proposals
- Evaluation criteria
- Financial evaluation
- Advertising the RFP
- Issuing the RFP
- The preproposal conference
- The evaluation process
- Converting the proposal to a concession agreement
- Streamlining the RFP
- Concession workforce issues
- Strategies for increasing local participation
- Using technology to streamline the solicitation process
- International concession contracting practices

## 10.1 Concession Procurement Approaches

U.S. airports and passenger terminals with few exceptions are publicly owned, and, therefore, the public procurement requirements established by the airport's governing body must be followed. Airport authorities have adopted policies that are consistent with the specialized needs of airports. Operators of airports that are units of a city, county, or state government typically follow more general and less efficient procurement requirements that may place additional burdens on the airport operator.

Nevertheless, the fundamental practices in selecting concession tenants are the same regardless of the form of governance. The competitive proposal or Request for Proposals (RFP) process is the standard industry approach for soliciting, evaluating, and selecting concessionaires. However, other approaches are also used, depending on the nature of the desired concession or service.



### 10.1.1 Bidding to Specifications

Competitive bids were, at one time, the dominant approach to concessionaire selection. After World War II, commercial airlines were flourishing and cities across the country were looking for ways to finance the construction of new airports and terminals. Today, airports have well-established credit ratings with relatively easy access to the capital markets. In the 1950s and 1960s, financing airports was more challenging. Cities and counties wanted new airports, but did not want to fund them with general revenues or bonds backed by general revenues. The financial markets often required airport sponsors to negotiate long-term lease and use agreements with their airlines and concessionaires as a means of providing guaranteed revenues to support the issuance of airport revenue bonds.

As a result, concession agreements were typically awarded to companies that proposed the highest guaranteed revenues using a process called bidding to specifications, with bidders agreeing to build and operate concessions according to detailed requirements established by the airport sponsor. The bidder with the highest total guaranteed revenue in each year of the concession agreement was awarded the concession privilege.

These exclusive long-term agreements provided guaranteed revenue to the airport enterprise at a time when airport operators needed to demonstrate financial capacity. Over time, as passenger traffic grew and airlines entered and left markets, it was recognized that it was the local market, and not the airlines, that drove passenger traffic demand. As a result, long-term airline agreements and concession agreements became less important.

Where a single concession agreement covered a major category, the agreement was called a retail or food and beverage “master concession” agreement. At some airports, a single master concession agreement was awarded, which included both food and beverage and retail privileges. Airports where some form of master concession agreement was/is used included those serving Atlanta, Denver (Stapleton), Orlando, Philadelphia, San Francisco, Seattle-Tacoma, and Tampa, among others. The same master concessionaire has been used at Tampa International Airport since the airport opened in the early 1970s.

A key complaint with exclusive long-term agreements was the quality of service. Over time, the high guaranteed revenues often resulted in high prices and poor service, and airport concession programs earned deservedly poor reputations for pricing, quality, and value. It became clear that a more sophisticated approach to providing airport concessions was needed.

Bidding to specifications has lost favor for food and beverage, convenience, and specialty retail. However, bidding to specifications is still used for some services, such as baggage carts and foreign currency exchange, and often for duty free privileges, where the airport operator’s goals may be largely financial and service levels are customarily high.

### 10.1.2 Requests for Proposals

Over time, as dissatisfaction with concession programs grew, airport operators shifted to the RFP process.

The RFP process allows airport operators to assess a variety of factors in the selection of concessionaires and encourages proposers to consider other factors in addition to guaranteed revenues. Criteria are established, with proposals evaluated against the established criteria. In this way, proposals can be evaluated based on customer service, investment, brands, pricing, training, service standards, and other criteria used. As experience was gained with this process, it became clear that a good concessionaire that met the criteria established in the RFP was capable of achieving higher sales than in cases where the concession privileges were awarded using a



straight competitive bid. The change from the competitive bid to the RFP approach and the rising expectations of airport customers and management are among the key factors that led to more competitive, sophisticated, branded, and passenger-friendly concession programs.

The standard practice is to issue an RFP that is open for response to any party meeting a set of minimum qualifications stated in the RFP. Each proposer's technical submittal and financial offer is evaluated by a selection committee and the proposer offering the best overall proposal is recommended for award.

### 10.1.3 Statements of Qualifications

In some instances, a two-phased competitive selection process is used, in which a formal request for a Statement of Qualifications (SOQ) is issued to solicit information from potential proposers or bidders that will allow the airport operator to narrow the field of potential proposers or to ensure that only qualified firms compete in a competitive proposal process.

The SOQ can also be used to select qualified firms for direct or competitive negotiations in instances where there are a limited number of providers or where the airport operator is open to considering alternative solutions.

The SOQ will typically ask for a narrow range of information such information about the company, its location, office, personnel, and capabilities; experience with similar projects; general financial information indicating, on a preliminary basis, necessary financial capacity; and demonstration that the respondent meets or exceeds the minimum qualifications to be considered in the next phase of the procurement. Concession privileges are rarely awarded based on qualifications alone.



### 10.1.4 Direct Negotiation

Another approach to awarding concession privileges, and the one that is least used, is direct negotiation. With direct negotiation, the airport operator negotiates with a single concession provider to reach agreement on contract terms.

Direct negotiation is most often used when there is only a single concession provider in a category, or when the nature of the concession is unique, or when the incumbent concessionaire has made considerable, recent, unamortized capital investments. Because there is no competition for the award of the privileges, direct negotiation is often avoided in favor of bidding to specifications or an RFP process. This is the case even when it is likely that only a single proposer will respond in order to avoid criticism that the process lacks transparency or that favoritism is involved.



### 10.1.5 Other Approaches

In addition to the main approaches to concessionaire selection described above, other approaches are occasionally used, depending on the circumstances. These include competitive negotiations and the two-envelope approach.

#### *Competitive Negotiations*

Although competitive negotiations are used rarely, they can be useful for complex procurements or cases in which there are a small number of potential service providers. Under this approach, proposers are ranked and negotiations are conducted with the top-ranked proposers. Each proposer has the opportunity to improve their proposal, until "best and final offers" are received and one clear winner emerges.





### The Two-Envelope Approach

Another variation that is used occasionally combines elements of bidding to specifications with an RFP. Under this approach, technical proposals, included in the first envelope, are evaluated against a set of established criteria. Minimum qualifications are established for consideration of technical proposals. Those proposals meeting the minimum qualifications and achieving a certain scoring threshold then advance to a second stage, during which their financial proposals, contained in the second envelope, are opened. The proposer with the highest financial offer is then declared the winner.

The two-envelope approach allows the airport operator to establish qualitative criteria to ensure that only those proposers meeting a certain level of qualifications and capabilities are eligible to have their financial offers opened. This approach is helpful in ensuring that an unqualified proposer does not “buy” the concession by submitting a financial offer that may not be sustainable over the term of the agreement or submit a financial bid that will result in unacceptable levels of service or pricing to passengers.

The two-envelope approach is still used occasionally in circumstances where local procurement regulations or other considerations make it difficult to differentiate between proposers. The RFP process has, at most airports, replaced the two-envelope approach.

## 10.2 Requests for Proposals—the Standard Practice



The RFP is the standard practice for selecting concessionaires at airports worldwide. Figure 10-1 shows the method of awarding food and beverage and retail concessions at large, medium, and small hub airports. In the surveys conducted for this research, 80% of participants indicated that the RFP is the approach used at their airport; only one airline and two airport concession managers indicated that they issued RFPs on an invitation-only basis to a limited selection of potential proposers.

Unlike bidding to specifications, which relies on one key financial variable, the RFP process allows consideration of multiple variables that may include the proposed concept, quality and amount of investment, experience and record of accomplishment of the proposer, the management and operating plan, financial ability to perform, and a financial offer.

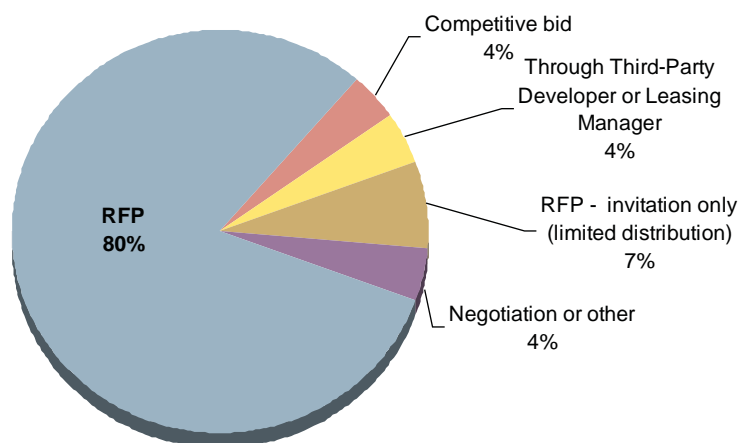

Note: Numbers may not add to 100% due to rounding.

Source: LeighFisher using data from the airport surveys conducted for ACRP Project 01-11.

**Figure 10-1. Method of awarding food and beverage and retail concession privileges (large, medium, and small hub U.S. airports).**

Proposals received in response to an RFP are typically reviewed by a panel of evaluators, which, depending on local procurement requirements, may be called an evaluation panel, selection panel, selection committee, or other name. Evaluators, depending on local laws or ordinances, may include airport staff members, local citizens with some background in the subject matter, airport board members, employees of sister agencies, and outside experts such as consultants or staff from other airports. At some airports, concession staff may be included as evaluators, while at other airports, these staff members serve as nonvoting facilitators.

Each airport operator has its own set of internal policies with respect to the award of concession privileges. In the case of airports operated as a department of city, county, or state government, or by appointed dependent authorities of a larger unit of government, the airport operator's concession procurement policy is shaped by local and/or state law or ordinance. The typical sections of an RFP are shown in Table 10-1. The descriptions of "typical" elements of RFPs should be considered as generalized descriptions of common industry practices that should be adapted to applicable local and/or state law.

**Table 10-1. Typical contents of a request for proposals.**

<ol style="list-style-type: none"> <li>1. General Description of the Business Opportunity <ul style="list-style-type: none"> <li>– Airport operator's goals for the concession program</li> <li>– Schedule for the process</li> <li>– Pre-proposal conference</li> <li>– Other requirements</li> </ul> </li> <li>2. General Airport and Airline Information <ul style="list-style-type: none"> <li>– Airport and service area</li> <li>– Airlines and the destinations they serve</li> <li>– Historical passenger statistics</li> <li>– Description of the current concession program, including space and sales</li> </ul> </li> <li>3. Detailed Description of the Business Opportunity <ul style="list-style-type: none"> <li>– Locations</li> <li>– Packages (if more than one)</li> <li>– Key business terms</li> <li>– Airport operator's goals, brands, local concepts, etc.</li> </ul> </li> <li>4. Other Doing-Business Issues <ul style="list-style-type: none"> <li>– Support space</li> <li>– Deliveries by suppliers</li> </ul> </li> <li>5. Development Requirements <ul style="list-style-type: none"> <li>– Design standards/guidelines</li> <li>– Design review</li> <li>– Turnover date</li> <li>– Condition of space at turnover</li> <li>– Construction coordination</li> <li>– Utilities</li> </ul> </li> <li>6. Submittal Requirements <ul style="list-style-type: none"> <li>– Minimum qualifications</li> <li>– Financial terms and variables – minimum annual guarantee (MAG), percentage rent, minimum investment requirement</li> <li>– Other technical information (see Table 10-2)</li> </ul> </li> <li>7. Evaluation Process <ul style="list-style-type: none"> <li>– Criteria and weighting</li> <li>– Selection process</li> <li>– Interviews</li> </ul> </li> <li>8. Attachments <ul style="list-style-type: none"> <li>– Draft concession agreement</li> <li>– Required forms</li> <li>– Submittal checklist</li> <li>– Design standards/guidelines</li> <li>– Lease outline drawings</li> </ul> </li> </ol>
--



### 10.3 Minimum Qualifications

A standard practice in the award of concession privileges is to establish minimum qualifications, whereby a level of experience, capability, or business volume is used as a threshold for consideration of bids or proposals. Minimum qualifications may include an experience element, for example, 3 to 5 years of experience operating a similar business, and a volume of past sales element, using a percentage (for example, 50%) of the expected business volume for at least 3 of the last 5 years.

In some cases, airport experience may be required, such as in the award of agreements for multiple concession locations. Proposal bonds, proposal guarantees, or sureties may also be required. Additional minimum qualifications are sometimes used, in the form of disqualifiers, such as not being in default under any current agreements with the airport operator, or having no lawsuits pending against the airport sponsor/operator, or no prior judgments or pending lawsuits that would, in the opinion of the airport operator, disqualify the proposer from consideration.

Minimum qualifications are important in any selection process because they are objective, quantifiable, and established before the process begins. Without them, proposals from unqualified respondents may have to be reviewed, which increases the workload of evaluation panels, and may lead to challenges. Minimum qualifications can be helpful to potential proposers by discouraging unqualified proposers from spending time and money unnecessarily.

### 10.4 Typical Elements Required in Proposals

Table 10-2 lists the typical elements required in proposals, which are discussed below.

**The transmittal letter** is a one- or two-page letter signed by an officer of the proposer that identifies the legal entity, key contact person, addresses, telephone number, fax number, and email addresses to be used in all communications relevant to the proposer. This information ensures that all communications are forwarded to a single point of contact. Care should be taken to avoid multiple points of contact—for example, a local manager in addition to a corporate business development executive—as this can result in faulty notices that can put the overall process at risk.

**The executive summary**, often page limited, describes the key elements of the proposal. Executive summaries can be helpful by providing an overview of the proposal and can easily be

**Table 10-2. Typical elements required in proposals.**

- |     |   |
|-----|---|
| 1.  | Transmittal letter                          |
| 2.  | Executive summary                           |
| 3.  | Qualifications and experience summary       |
| 4.  | Concept descriptions and merchandising plan |
| 5.  | Management and operating plan               |
| 6.  | Financial statements                        |
| 7.  | Design submittal                            |
| 8.  | ACDBE participants                          |
| 9.  | Pro forma revenue and expense projections   |
| 10. | Proposal form                               |
| 11. | Proposal bond, guarantee, or surety         |
| 12. | Addenda acknowledgement form                |
| 13. | Other required information                  |
| 14. | Submittal checklist                         |



extracted to summarize the key elements of each proposal. The contents of executive summaries can be set forth in the RFP to ensure that key information is included.

**The qualifications and experience summary** is often a detailed questionnaire that provides a structure for all proposers to use in conveying important information on the legal form of the organization, company history, domicile, ownership interests, other concession operations, financial qualifications, references, assurances on matters such as prior and current litigation, ACDBE status, prior bankruptcy filings, and other organizational issues.

**The concept descriptions and merchandising plan** is where the proposer describes how it intends to use the concession space, the concept proposed for each location, the merchandise list or menu items or services to be offered, and why the proposer believes its proposed use is the best use of the space.

**The management and operating plan** describes the staffing levels, key staff, employees per shift, management structure, reporting relationships, and basic procedures that will apply to the concession or service. Summaries of training and customer service programs, incentive programs, turnover statistics, and other information about the proposer's workforce are included here.

**Financial statements** are provided for the most recent 2 years of the entity guaranteeing the proposal terms. If a proposer is relying on the qualifications of its parent company, the financial statements of the parent company should be evaluated, and the parent company should be the party executing the concession agreement or guaranteeing the financial elements of the proposal.

**The design submittal** typically includes the proposed layout of the space(s) with dimensions based on lease outline drawings included with the RFP; renderings of the concession exterior front; a narrative description of the design and how it meets the airport operator's design guidelines and supports the overall goals for the concession program; and, in some cases, printed versions of material boards for each unit. Some airport operators also require the original material boards.

**ACDBE participants** must be identified, along with a description of the level of participation in terms of annual sales and space, and a description of the legal form of participation (e.g., joint venture or sublease) by including a copy of the proposed agreement between the proposer and the ACDBE. The RFP may also ask for particulars on the contractual relationship, such as the level of investment by the ACDBE or its role in the overall management of the joint venture.

**Pro forma revenue and expense projections** are provided with a pro forma projection of revenue and expense for each concession location, usually for a minimum of 5 years or for the length of the term of the agreement, based on the requirements included in the RFP. The pro forma projection provides the airport operator with evidence that the proposer has taken into account the requirements of the RFP, the locations and size of the airport's passenger market, and the cost of doing business. It also provides insight into how the proposer intends to operate the business and allows the different proposals to be compared in terms of labor costs, the cost of goods sold, gross margins, or other metrics. When proposers use different underlying assumptions on traffic growth and price inflation, the pro forma revenue and expense projections will be difficult to compare. For this reason, it is recommended that the RFP include the airport's passenger forecasts to be used by all proposers (or an assumed number of future passengers based on a reasonable metric if an official forecast does not exist). The explained passenger assumptions or forecast should contain a caveat that the airport operator does not warrant that the explained passenger levels are guaranteed and that they are provided solely for the purpose of ensuring a common basis for comparison.

Stating a common, conservative inflation assumption for projecting sales can also be helpful, as would requiring that the pro forma analyses be prepared in "real" terms (i.e., without any underlying inflation assumed). In this way, expense and revenue projections provided by proposers can



be more readily compared, which would help avoid problems should a proposer's forecasts become an issue during the award process in the event of a protest or other event.

**The proposal form** is a legally binding document executed by an officer of the proposing company authorized to do so, which contains a clear and concise statement of the financial offer, including percentage rent, minimum guarantees, and other variable payments. The statement should track with the language in the concession agreement and the RFP. The proposal form's purpose is to eliminate any ambiguity about future rents, fees, and charges that may be described elsewhere in the proposal. Including the proposal form as a separate form rather than within a required section of the RFP will avoid editing errors or the failure to incorporate revisions into the proposals, ensure that a corporate officer has attested to the offer, and keep it from getting lost among all the other requirements of the proposal. The proposal form should also include the proposer's offered investment, as defined in the RFP.

**The proposal bond, guarantee, or surety** is an amount of money, or a promise to pay money from a third party, that is forfeited if the proposer fails to execute the concession agreement. The proposal bond should be set in an amount that would compensate the airport operator for its costs resulting from delay in the award of the agreement.

**The addenda acknowledgement form**, to be signed by the proposer, lists and certifies that each issued addendum to the RFP has been read.

**Other required information** includes required affidavits, insurance certificates, licenses to do business, ACDBE certifications, evidence of financial capability, a sample subtenant agreement, and other information and forms specific to each airport.

**A submittal checklist** showing the required elements of the RFP can help reduce errors and omissions in proposals. The checklist should show each required section and all required forms.

## 10.5 Evaluation Criteria



Most airport operators use weighted evaluation criteria, which provide structure and a common basis for use by all evaluators. Weighted criteria are preferred by proposers, as they provide all proposers with a common understanding of what is important to the airport operator and the relative importance of each criterion. Table 10-3 shows the percentage of airports where weighted evaluation criteria are used, based on the surveys conducted for this research.



Some airport operators use unweighted criteria, leaving it to the evaluation panel to select the best proposal based on its understanding of the needs of the airport operator and the contents of the RFP. Airport operators that prefer unweighted criteria believe that they result in a greater consensus and eliminate second-guessing of the evaluation panel's scoring in the event of a challenge to the recommendation to award. When unweighted criteria are used, proposals are scored in

**Table 10-3. Use of weighted evaluation criteria by hub size (food and beverage and retail concessions).**

	Large Hubs	Medium Hubs	Small Hubs
Yes	72%	71%	45%
No	11%	23%	55%
Developer or Leasing Manager selects	11%	0%	0%
No response	6%	6%	0%
	100%	100%	100%

Source: LeighFisher using data from the airport surveys conducted for ACRP Project 01-11.

**Table 10-4. Weightings of evaluation criteria for each major concession category.**

Evaluation Criterion	Food and Beverage	Convenience Retail	Specialty Retail	Duty Free
Financial (MAG/Percentage Rent)	17%	18%	13%	22%
Pro Forma/Ability to Drive Sales	15%	12%	4%	11%
Strength of Brand or Concept <sup>1</sup>	4%	16%	16%	14%
Design/Aesthetics <sup>1</sup>	4%	14%	7%	15%
Local Brand/"Sense of Place"	8%	8%	2%	7%
Experience and Quality of Past Performance	7%	7%	16%	8%
Management and Operations Plan	7%	7%	2%	5%
Pricing to the Customer	5%	5%	8%	7%
Customer Service	5%	5%	8%	6%
Local Operators	4%	4%	4%	4%
Financial Ability to Perform	2%	3%	14%	2%
Other Criterion	1%	1%	7%	0%

Source: LeighFisher using data from the airport surveys conducted for ACRP Project 01-11.

rank order by each evaluator. There is no overall structure to the ranking. Proposers argue that unweighted criteria provide little transparency, and it is impossible to know the basis for the evaluation panel's decision. Aligning the evaluation criteria with the goals for the concession program will eliminate confusion on the part of proposers and evaluation panel members alike.

Table 10-4 shows the average weighting of evaluation criteria for large, medium, and small hub airports for each major concession category. The financial criterion (MAG and percentage rent) ranks highest in each concession category except specialty retail.

## 10.6 Financial Evaluation

Airport operators use several approaches for structuring the financial component of proposals. Typically, proposers will make a financial offer based on a minimum annual guarantee, percentage rent, or a combination of the two. Some airport operators set the MAG and percentage rent and select the concessionaire based on other criteria. Table 10-5 shows the financial elements evaluated in proposals according to hub size for food and beverage and retail concessions.

**Table 10-5. Financial elements evaluated in proposals.**

	Large Hubs	Medium Hubs	Small Hubs	Average Large, Medium, Small Hubs
<b>FOOD AND BEVERAGE</b>				
Both MAG and Percent Rent	33%	18%	55%	32%
Neither (financial terms are fixed)	22%	6%	18%	15%
Annual Guarantee (MAG)	17%	41%	18%	25%
Percentage Rent	17%	6%	0%	11%
No response	11%	29%	9%	17%
	100%	100%	100%	100%
<b>RETAIL</b>				
Both MAG and Percent Rent	33%	35%	55%	38%
Annual Guarantee (MAG)	28%	24%	8%	23%
Percentage Rent	17%	12%	0%	11%
Neither (financial terms are fixed)	11%	6%	9%	9%
No response	11%	23%	18%	19%
	100%	100%	100%	100%

Source: LeighFisher using data from the airport surveys conducted for ACRP Project 01-11.



Based on the surveys conducted for this research, as shown in Table 10-5, a plurality of airport operators and a majority of small hub airport operators ask for proposers to offer minimum annual guarantees and percentage rent. The next most commonly implemented approach is to evaluate the proposed minimum annual guarantee only. However, at large hub airports, the second most implemented approach for food/beverage concessions is to fix both the minimum rent and the percentage rent, whereas this approach ranked last for retail. If the approach in which the minimum rent and percentage rent is used, the airport operator is relying on other aspects of the proposal to provide a basis for assessing future revenue, including the pro forma sales projection and the strength of the proposed brands or concepts and their ability to drive sales. By setting the financial elements, airport operators can avoid unrealistic bids, which can cause problems later if the concessionaire is unable or unwilling to pay rent and then seeks to renegotiate the terms of the agreement.

Evaluating proposed percentage rents can be difficult. While a higher percentage rent may be preferred, the concept associated with the higher percentage rent may not be capable of generating high sales. Consider, for example, a proposer that offers a generic burger concept and offers to pay 18% of sales as rent, while another proposer offers to operate the leading national burger brand and offers 15% of sales as rent. If the generic burger concept generated \$1,600,000 in sales, a proposed rent of 18% would yield \$288,000 in revenue to the airport enterprise. To provide equivalent rent, the branded location would need to produce higher gross sales— $\$1,920,000 \times 15\%$ .

At this point, the evaluators need to consider the performance of the two concepts in other airport locations. If the evaluators believe that the branded concept is capable of producing gross sales greater than \$1,920,000, or 20% higher than the generic concept, the airport enterprise will be financially better off with the branded concept. In this case, the information on performance at other locations showed that the branded concept clearly outperformed the generic concept, and the difference in performance would more than offset the difference in percentage rent. The branded concept also scored higher in other criteria.

Guaranteed revenues can be similarly difficult to assess. Higher guaranteed rent may be less advantageous if an alternative proposal will generate greater revenue based on sales.

### 10.6.1 The “85% Rule”



The risk of foregoing revenue from a MAG-based proposal is reduced when a MAG-adjustment provision is included in the concession agreement. A common practice used throughout the airport industry is to reset the MAG each year based on 85% of the prior year’s total payments to the airport enterprise (MAG, percentage rent, or both), with the first-year MAG acting as the baseline.

### 10.6.2 Weighting the Financial Element

The financial offer is not the only criterion with financial implications. Other criteria also relate to the ability of the proposed concept to generate sales and revenue. These criteria include the strength of the brand or concept, product prices, and the experience of the operator, particularly in operating the proposed brand or concept. In addition, the proposed design and the proposed investment in the concession unit can make a material difference in overall performance.

For these reasons, it may be useful for evaluators to consider both the financial offer and the overall strength of the operator and the concept in determining which proposer would produce the highest revenue to the airport enterprise over the term of the agreement. While such an evaluation may be partly subjective, requesting hard sales performance data for other locations can contribute to informed decision-making.

### 10.6.3 Unrealistic Sales Projections

The use of unrealistic sales and revenue projections presents a potential problem in evaluating financial performance. Proposers may feel pressure to overstate expected sales to avoid appearing less competent than their competitors. In a few cases, proposers may grossly overstate sales and revenues to provide a basis for challenging the award if unsuccessful.

First, the airport operator should have baseline sales and revenue projections for the concession spaces being considered for award. These baseline projections should be developed during the planning phase and be based on a reasonable outcome using benchmark data. Sales and revenue projections should be completed using both a “top-down” approach, with overall projected sales and revenue per enplaned passenger in line with the benchmarks, and a “bottom-up” analysis, with sales and revenue projected for each location using current performance data for the space, performance of individual units in the airport, or performance of individual units at other airports as benchmarks. As a check, the projected sales per enplaned passenger for all units should equal the overall total based on the benchmark. By establishing a baseline sales and revenue projection, the airport operator will have a reference point from which to assess the reasonableness of the proposals.



Second, proposers should present data for comparable locations at other airports, including the size of the unit, sales per enplaned passenger based on exposed passengers, and sales per square foot. These data, combined with data received from other proposers, can provide an overall set of comparables to be used in assessing performance based on the record of the proposer.



Table 10-6 presents an example of weighted evaluation criteria from a large hub airport food and beverage RFP. Each criterion is listed, along with descriptors that help the evaluators understand the criterion. Five overall criteria are used in this example, with a total of 100 points. More criteria and more points can be used.

## 10.7 Advertising the RFP

The airport operator has an interest in receiving as many responsive qualified proposals as possible. More competition increases the available choices for the evaluators. Therefore, it is incumbent on airport operators to inform as many potential participants as possible of upcoming opportunities far in advance through networking sessions, written notices, and personal contacts to the extent allowed. Formal proposer lists may be maintained to identify interested parties. In addition, advertising that the RFP will soon be available several weeks before issuance will generate interest and allow time for potential proposers to plan for the release of the RFP.



Most airport operators will advertise in local newspapers of general circulation and business publications, as well as airport industry trade publications. Both the Airports Council International-North America (ACI-NA) and the American Association of Airport Executives (AAAE) have websites and newsletters where airports can list their business opportunities and solicitations. Some airport operators also publish notices in *Airport Revenue News* and other industry publications. Companies that have expressed interest in future concession opportunities should also be notified by regular or electronic mail.

## 10.8 Issuing the RFP

Historically, airport operators mailed RFPs to interested parties and sometimes charged a fee for the RFP to recover copying/printing, mailing, and other administrative costs. Detailed records of who received the RFP were maintained so that addenda could be distributed to those

**Table 10-6. Example of weighted evaluation criteria.**

<b>Overall Mix of Brands/Concepts</b> <ul style="list-style-type: none"> <li>– Mix of brands including local brands in creating a "sense of place"</li> <li>– Individual concepts and suitability</li> <li>– Strength of brand(s) – local, regional, national</li> <li>– Rationale and justification for the proposed brand/concept</li> </ul>	25
<b>Financial Return and Investment Commitment</b> <ul style="list-style-type: none"> <li>– Financial return over the term of the concession agreement and reasonableness of the pro forma</li> <li>– Pro forma sales and revenue projection – first 5 years</li> <li>– Supporting justification for sales projection (benchmarks, performance of other businesses, rationale, etc.)</li> <li>– Statement of how the proposed concepts will maximize sales and revenue, including anticipated capture rate and target market</li> <li>– Capital investment commitment</li> </ul>	25
<b>Customer Service, Marketing, and Operations Plan</b> <ul style="list-style-type: none"> <li>– Training, quality assurance plan, plan for handling peak periods and increasing throughput</li> <li>– Customer service standards, approach to providing service during peak periods, customer feedback, complaint and resolution process, service monitoring, and quality control</li> <li>– Customer payment types and additional service enhancements</li> <li>– Management plan, including on-site management, local hiring, training, development</li> <li>– Merchandising and pricing plan</li> <li>– Sustainability plan (recycling, power conservation, use of locally produced products, etc.)</li> <li>– Marketing and promotions plan</li> </ul>	20
<b>Aesthetics and Design</b> <ul style="list-style-type: none"> <li>– Proposed design(s), incorporation of "sense of place"</li> <li>– Use of available space to maximize sales and customer service</li> <li>– Consistency with tenant design standards</li> </ul>	15
<b>Experience and Qualifications</b> <ul style="list-style-type: none"> <li>– Experience with particular brand or concept; local management; record of accomplishment; depth of experience; and support systems.</li> <li>– Experience, qualifications, track record of company</li> <li>– Previous operating experience</li> <li>– References</li> <li>– Recognition, awards, favorable reviews, honors, etc.</li> <li>– Demonstrated financial ability to perform</li> </ul>	15
<b>TOTAL POINTS</b>	<b>100</b>

parties. Written requests for the RFP were generally required before the RFP was sent to an interested party.



Many airport operators have now switched over to electronic media procurement processes whereby RFPs and addenda are posted on a website and can be downloaded for free. This switch has greatly streamlined the process and made the RFPs more easily accessible to interested parties.

## 10.9 The Preproposal Conference



Preproposal conferences provide airport staff with the opportunity to explain the RFP, the form of concession agreement, the design guidelines, airport operating characteristics, and current performance, as well as provide other information that a proposer will need to submit a fully responsive proposal. Even if most participants are familiar with this information, it is important that all potential proposers fully understand the nature of the concession opportunity. Reducing



uncertainty on the part of potential proposers leads to greater competition and more robust and competitive proposals. Full disclosure of requirements and conditions also reduces the potential for challenges or contests later in the process.

For complex RFPs, including those with challenging design and construction requirements, making the preproposal meeting mandatory increases understanding of the opportunity, decreases questions during the process, and reduces the risk of claims or challenges after selection. Site visits should also be conducted to allow potential proposers to see the spaces and understand the locations.

## 10.10 The Evaluation Process

Members of evaluation panels have other jobs and responsibilities. The work required to evaluate complex and comprehensive proposals can be overwhelming. Therefore, members of evaluation panels should be appointed based on their ability to devote the time necessary for a fair evaluation. Given the extensive time and cost requirements borne by proposers, airport operators owe them a fair and comprehensive evaluation.

Concession managers can minimize workload and achieve more informed evaluations by implementing a number of techniques:

- **Requiring tabs** between each section of the proposal.
- **Standardizing the format of requested tabular information** to provide concise information that can more be readily understood and compared and to ensure completeness of the information requested.
- **Aligning the major sections of proposals with the evaluation criteria** and including all of the information relative to a criterion in a single section.
- **Standardizing the underlying traffic assumptions** and thereby providing a common basis for comparing sales and revenue projections, resulting in a fairer and more transparent process. (A disclosure should be included that the traffic assumptions are for purposes of evaluating proposals only and that the airport operator does not guarantee that this level of traffic will actually occur.)
- **Requiring justification and benchmarks for sales projections** by reviewing the performance of similar units or programs at other airports in terms of sales per enplaned passenger exposed to the concession location as a basis for understanding the projections. Where sales projections significantly exceed benchmarks, further explanation is required.
- **Providing consultant or qualified internal staff expertise on technical matters** such as reviewing financial statements to evaluate the financial strength of proposers and comparing the pro forma financial sales and revenue offers. This will help to provide a common set of data.

## 10.11 Converting the Proposal to a Concession Agreement

A draft of the concession agreement should be included as part of the RFP. Requiring a statement that the proposer will execute the form of agreement as is or allowing the proposer to take exception to contract provisions in its proposal will reduce misunderstandings, allow for a fairer evaluation, and streamline the contract execution process. Material changes to contract terms after award but prior to execution can lead to legal challenges to the award process and encourage proposers to use similar tactics in future concession solicitations.

Eliminating uncertainties about the terms of the concession agreement before the deadline for proposal submission will ensure that no surprises or misunderstandings occur wherein a proposer would demand unforeseen changes to the concession agreement.



Different approaches are used to ensure that the proposer will execute an agreement that is satisfactory to the airport operator. These include the following:

- Requiring a statement of exceptions to the concession agreement and a precise statement of the rationale for those changes
- Including any proposed changes to the agreement in the evaluation and scoring of the proposal
- Stating that required or requested changes to the agreement will be taken into account in determining whether the airport operator will be able to negotiate a final concession agreement with the proposer
- Stating that no other changes to the concession agreement will be considered by the airport operator unless stated in the written proposal by the proposer

Ample time should be allowed to resolve questions or ambiguities during the proposal phase by written addenda to the RFP. Proposers will want clarity on the RFP and concession agreement. Not all airport operators use the same practices and language in their documents, so proposers will ask for clarification if they are unsure about the meaning.

## 10.12 Streamlining the RFP



The standard form of the RFP will evolve over time, as new policies are adopted and experience is gained with its use. It is easy for RFPs to become cumbersome and difficult for proposers to understand. Revising the RFP to eliminate unnecessary requirements and redundancies can make the procurement process easier for all concerned.

RFPs can be especially difficult for smaller companies that lack the resources of large national concessionaires. Specialist concessionaires may be adept at their core business, but find the vagaries of the RFP process overwhelming. Streamlining the RFP may encourage greater participation. Some suggestions for simplifying the RFP include the following:

- **Place less emphasis on processes** such as formal training programs, maintenance plans, construction schedules, and other housekeeping matters. In today's competitive environment, a concessionaire capable of operating a desirable brand or concept will operate to the brand's standards, and the operating risk for the airport enterprise is reduced.
- **Treat design and construction schedules as a requirement, not an element to be evaluated.** In terms of the development process, it is important that the unit opens on time. Rather than evaluate detailed construction schedules prepared by proposers based on limited information for work that may begin a year later, design and construction schedule slippage can be mitigated by inserting a penalty clause in the concession agreement that provides for liquidated damages in the event of delay in opening on time. The penalties will provide incentive for the concessionaire to meet the airport operator's schedule.
- **Limit design submittals.** For smaller concessionaires and local operators proposing on individual spaces or small concession packages, the requirement to produce detailed plans, renderings, and material boards is expensive. Experience has shown that many airport operators will require substantial changes to the proposed design regardless of the quality of the initial submission. To reduce the cost of submitting proposals, the airport operator could require the proposer to submit only a statement of design intent, that is, a narrative describing the proposed design. Where there is concern over the cost to small businesses proposing on concession opportunities, one possible approach is to accept archival materials showing the proposer's other airport and street locations and narrative on how those designs would be adapted to the airport operator's design standards (if any). The risk of an unsatisfactory buildout can be mitigated by (a) requiring an investment commitment sufficient to ensure a quality design and buildout; (b) publishing standards for tenant design, materials, signage, and so forth that



establish a clear baseline of what is required; and (c) establishing requirements for design review at specific stages of the design process, for instance at the 30%, 60%, and 95% design stages. By using all of these techniques, the airport operator can ensure a successful buildout without requiring all proposers to incur high submission costs.

- **Limit the number of pages** to increase focus on what is important and reduce the workload of the evaluation panel, which can be significant on major procurements.
- **Award no points for expensive covers, dividers, and artwork.** For major competitive selections, large companies may spend considerable money on expensive covers, dividers, and artwork. These proposal design elements provide no additional information and can have a subliminal effect on evaluators in their objectivity regarding the contents of the proposal.
- **Place less emphasis on the proposer's financial size.** Demonstrating the financial capacity to build and operate the concessions is relevant. Beyond a certain level, however, the proposer's financial size becomes irrelevant. Awarding points for excess financial capacity is a hidden bias that may unfairly discriminate against smaller companies and favor larger ones when both have the financial capacity to develop and operate the concession.
- **Require interviews rather than presentations.** Many airport operators and concessionaires welcome the opportunity to discuss the proposals, ask and answer questions, and get to know one another's key personnel. When airport operators require formal presentations, concessionaires with large business development staffs and strong presentation skills are able to spend a lot of time and money preparing impressive presentations, which may or may not have anything to do with answering the key question—which proposer and concept will do the best job for the airport enterprise. Interviews can be kept simple and focused on the essential questions and clarifications arising from review of the written proposals.



## 10.13 Concession Workforce Issues

Current concession employees can be an influential stakeholder group in the concession procurement process. Issues important to concession employees should be considered at the airport operator's policy-making level, as they have the potential to shape business terms and the structuring of contract packages. The emphasis on these terms and packages will vary depending on local circumstances, and they may receive special attention at airports that engage concessionaires with unionized employees.

Labor and employment issues are often beyond the decision-making authority of concession managers, who should consult with senior managers when developing procurement documents. Still, anticipating these stakeholder issues and understanding the effects of the policy decisions on the procurement process will help prevent unintended consequences. Two common concession workforce issues are labor peace requirements and living wage policies.

### 10.13.1 Labor Peace

Where labor unions are influential, or where the concession companies have been organized by labor unions, airport operators may require a "labor peace" or "labor harmony" requirement to be included in RFPs. Labor peace provisions typically require proposers to reach prior agreement with relevant labor organizations that, if selected, there will be no interruption of service during the term of the concession lease agreement. As a condition for this agreement, unions will ask the proposer to agree to official neutrality in any union ratification vote and obtain prior approval to use a simplified card-check election procedure in lieu of more formal rules provided for under the National Labor Relations Act. In a card-check election, employees sign a card to indicate their support for recognizing the union. Union officials can collect cards until they have a majority in favor of recognition. There is no secret ballot. By agreeing to remain neutral, the



employer concessionaire agrees not to campaign against the union and waives the right to demand a secret ballot as provided in the National Labor Relations Act.

Concession employees have been organized at many airports. Under federal law, airport operators cannot require union recognition as a condition of selection or otherwise exert influence on relations between labor and management. However, airport operators have a legitimate, legally permissible interest in assuring continuous operation of the concessions, which forms the basis for adopting labor peace or harmony provisions in RFPs.

About 14% of airport operators in the surveys conducted for this research stated that a labor peace or labor harmony provision is required at their airports.

### 10.13.2 Living Wage



Some airport operators have adopted “living wage” policies that apply to businesses that contract with the airport operator. These policies sometimes have the effect of increasing labor costs, often to or near the level of union wages. Living wage rates and union wage scales may be a significant operating cost that has implications for concessionaire financial performance and on the decision to compete for the concession privilege.

Airport concession managers should understand how living wage policies and other local conditions, when combined with percentage rents, minimum annual guarantees, and other occupancy costs, affect concessionaires. High labor costs may be a factor that discourages companies from submitting concession proposals or reduces financial offers in proposals; concepts that have higher labor cost requirements may not be practical or feasible as an in-terminal concession.

### 10.13.3 Worker Retention



Some airport operators include worker retention policies in concession agreements, which require a successor concessionaire to consider hiring employees of the outgoing concessionaire. Worker retention programs can range from voluntary efforts, such as job fairs, to mandatory requirements, with current employees guaranteed employment by the new concessionaire unless a strong, compelling reason not to do so exists.

## 10.14 Strategies for Increasing Local Participation



Strategies for increasing local participation include the following:

- **Streamline the RFP process.** Local businesses are unlikely to be experienced in a governmental procurement process and may find the learning curve steep. Simplifying the requirements and focusing on the key elements vital to the selection can encourage more participation by local businesses.
- **Enter into licensing agreements.** Many airport operators encourage experienced airport concessionaires to enter into licensing agreements with local businesses. Such agreements can reduce risk for both the airport operator and the local business, while providing access to popular local concepts.
- **Conduct outreach meetings.** Comprehensive outreach meetings targeting local businesses, as well as other prospective concessionaires, can encourage greater participation in the RFP process. Unlike experienced airport concessionaires, local businesses may not understand the airport operating environment and constraints, such as security rules, employee badging, delivery restrictions, and peak departure periods. An outreach meeting can provide local businesses with the information needed to determine whether or not competing for a concession



is worth their investment in time and money. Even if the local business decides not to participate in the RFP process, it will have done so on the basis of an informed decision gained as part of the process, which will have the tangential benefit of creating goodwill for the airport in the local business community.

Topics that should be discussed at concession outreach meetings include the following:

- Nature of the opportunity, including the airport operator's goals and objectives.
- Types of concessions sought by the airport operator.
- Doing business at the airport, including hours of operation, security, deliveries, support space, peak demand periods, hours of operation, pricing policy, hiring challenges, security badging requirements, employee parking, and transportation.
- Airline traffic, including distribution of traffic in areas throughout the terminal(s).
- Timing of the RFP process.
- Performance metrics for current concessionaires, including annual business volume, sales per enplaned passenger, and sales per square foot.
- Development challenges, including the permitting process and recent data on buildout costs. For businesses without airport operating experience, it will be important to understand that higher per square foot development costs are offset by higher per square foot sales than would normally be experienced in a street or mall location.
- The RFP requirements; some airport operators also conduct separate training sessions on how to prepare for and respond to an RFP.

It can also be useful to hold a networking session in conjunction with the outreach meeting, as this allows local businesses to meet potential business partners, current concessionaires, and others with an interest in the concession program.

## 10.15 Using Technology to Streamline the Solicitation Process

Technology has the potential to make the procurement process easier for all concerned. Some of the ways that technology can be used are the following:

- **Electronic registration of potential proposers.** Some airport operators use electronic registration to allow interested parties to register their information and provide an email address for all future notifications related to the procurement.
- **Electronic distribution of RFPs and RFQs.** Placing the documents on the airport website can speed distribution of documents at little cost. Today, any potential proposer would be expected to have access to the Internet. Addenda to proposal documents can also be distributed in this manner.
- **Bulletin boards for questions and answers.** Password-protected electronic bulletin boards can be used by interested parties to ask questions about the procurement and by airport staff to post answers. Such bulletin boards would allow all potential proposers easy and fast access to questions and answers (or to an addendum, if a formal response is required).
- **Online preproposal meetings.** A number of web-based services are available for conducting online meetings and providing an electronic record of participation. Interested parties would log in to a meeting using a unique password. Online meetings can save travel time and expense for all participants while ensuring that common information is provided.
- **Electronic submission of proposals.** Used extensively in the private sector, submission of proposal documents by email, or on CDs or DVDs, can reduce production costs, save paper, and reduce the considerable cost of handling, distributing, securing, and maintaining proposal documents. Electronic copies made from the original files in Adobe portable document format



(.pdf) documents are far superior in quality and readability than scanned documents and are searchable by readers. Evaluators could receive electronic copies of proposals for review at home or at work. A paper original of the proposal executed by an officer of the proposer could serve as the official version of the proposal and would take precedence in the event of conflicts.

## 10.16 International Concession Contracting Practices

The operators of airports outside the United States face issues similar to those of their U.S. counterparts in the solicitation and award of concession agreements. Practices are more similar than dissimilar.

### 10.16.1 Competitive Selection



Competitive tendering of airport concession privileges is standard practice for airports in the United States and around the world. Most airports are owned by national, state, or local governments and conduct their business on an open competitive basis pursuant to laws requiring open competition and transparency. Among privately owned airports, which are common in the European Union, Australia, New Zealand, Mexico, and many other countries, a competitive tender process is also the standard practice. However, privately owned airports and publicly owned corporatized airports typically have the ability to negotiate term extensions or new agreements with strong performers. For example, the operators of two major European airports interviewed for this research project reported that “a high percentage” of agreements at one airport and up to 30% at the other were extended or renegotiated, but only for the top performers. At both privately owned and corporatized airports, which have a high degree of financial oversight, greater focus is often placed on financial performance and profitability in awarding and extending concession agreements.

### 10.16.2 Duty Free Tendering

When seeking proposals for duty free concessions, airport operators outside the United States are likely to ask proposers to identify the percentage rent they are willing to pay the airport enterprise by category. This approach takes into account the varying profit margins for different types of luxury merchandise such as perfumes and cosmetics, which have large margins, and electronics, which have smaller margins. This approach also has the effect of narrowing overall profit margins for the duty free concessionaires.

### 10.16.3 Duty Free Exclusive versus Nonexclusive

Most airport operators will award a single large duty free concession privilege. However, operators of airports with very large duty free or travel retail volumes may sometimes seek multiple operators. At Singapore Changi Airport, the concessions are separated into major categories such as liquor, cosmetics, and confectionery, and each is awarded separately. At Seoul Incheon International Airport, the duty free concession is separated into four major contracts with partial overlap on categories. At Amsterdam Airport Schiphol, several specialist concessionaires operate on a duty free and tax free basis. These airports are exceptions, however, and have very high sales volumes. The vast majority of airport operators enter into a single duty free concession agreement.



# Services, Storage, and Logistics

This chapter presents an overview of the behind-the-scenes elements of concession programs, including support spaces, the distribution of goods, and the handling of waste, including trash and recyclables. Airport terminals vary widely in configuration, layout, size, age, and condition. The basic principles described in this chapter can be adapted to each airport. The chapter discusses the following:

- Loading docks
- Security screening of goods
- Concession storage facilities
- Servicing routes and devices
- Use of centralized third-party logistics providers
- Waste collection, recycling, and removal
- Sustainability
- Food preparation

## 11.1 Loading Docks

Loading docks function as areas for receiving incoming goods to be delivered to the terminals and for picking up outgoing goods. Incoming goods may consist of inventory items for concessionaires (including food and beverages for restaurants), supplies and equipment for the airline offices, courier service deliveries, and the like. Outgoing goods may consist of trash, recycling materials, inventory returns, and the like.

Although the concessionaires are a primary user of a terminal's loading docks for delivery and waste handling, other terminal operations require deliveries and waste removal and are also served through the same loading dock facilities. Examples include restroom supplies, office supplies, and repair and maintenance supplies.

Components of/services accommodated at the loading dock area include the following:

- Receiving
- Security screening
- Incoming holding
- Waste holding
- Recycling holding
- Compactor
- Office
- Circulation

Loading docks should be located for easy access by service vehicles and should be separate from the public entrances to the terminal building. Loading docks also need to be conveniently





located in relation to freight elevators so that service traffic is separated from the main passenger elevator lobbies and public corridors and has direct access to the concessions units and/or the service/storage areas for the concessions. If not immediately adjacent to the service elevators, the loading docks should have immediate access to a service corridor leading to service elevators that provide the required access. The service route from the loading dock to the elevator needs to accommodate the transport of large shipments of goods.

Loading docks should be sized to accommodate the vehicles used to deliver or pick up materials to and from the building. Typical loading docks are built 55 inches above grade level to accommodate most trucks. If the bed height of vans and trucks varies more than 18 inches, at least one loading bay must be equipped with a dock leveler. Separate or dedicated loading docks should be considered for food service areas and dumpsters.

Loading docks are utilitarian spaces that should be designed for function and durability. However, it is also important that they be designed to ensure the safety and security of their users and the users of other nearby spaces. This type of space must be able to accommodate large vehicles, forklifts, and pedestrian traffic.

### 11.1.1 Number of Loading Bays

Table 11-1 presents loading dock requirements as a function of terminal concession floor area.

Figure 11-1 presents an approach to determining the number of loading docks required based on annual enplaned passengers assuming 15 square feet of concession space per 1,000 enplaning passengers.

### 11.1.2 Loading Area Size and Features

The size of the loading area is determined by using the planning ratio of 0.0006 square feet per annual enplaned passenger.



A ramp should be provided from the loading dock to the truck parking area to facilitate deliveries from small trucks and vans. This ramp should have a maximum slope of 1:12 and comply with Uniform Federal Accessibility Standards/ADA accessibility guidelines, ensuring that it may be easily maneuverable for deliveries on carts and dollies.

Other loading area requirements include the following:

- Edge guards and dock bumpers.
- Easy access overhead coiling door. These doors should be able to close completely and lock after business hours. At least one well-lit personnel door should be provided in addition to the overhead doors.
- Adjustable lighting fixtures to illuminate the interiors of trailers.
- Noise dampening features, including heavy concrete walls and absorptive acoustical surfacing.
- A design to prevent the collection of storm water near the dock.



**Table 11-1. Loading dock requirements as a function of concession floor area.**

Size of Terminal Concession Area	Required Loading Bays
Up to 50,000 square feet of gross floor area	1 per 25,000 square feet or fraction thereof of gross retail floor area
Between 50,000 square feet and 100,000 square feet of gross retail floor area	1 per 20,000 square feet or fraction thereof of gross retail floor area
Over 100,000 square feet of gross retail floor area	5 plus 1 per 50,000 square feet or fraction thereof of gross retail floor area over 100,000 square feet

Source: LeighFisher.

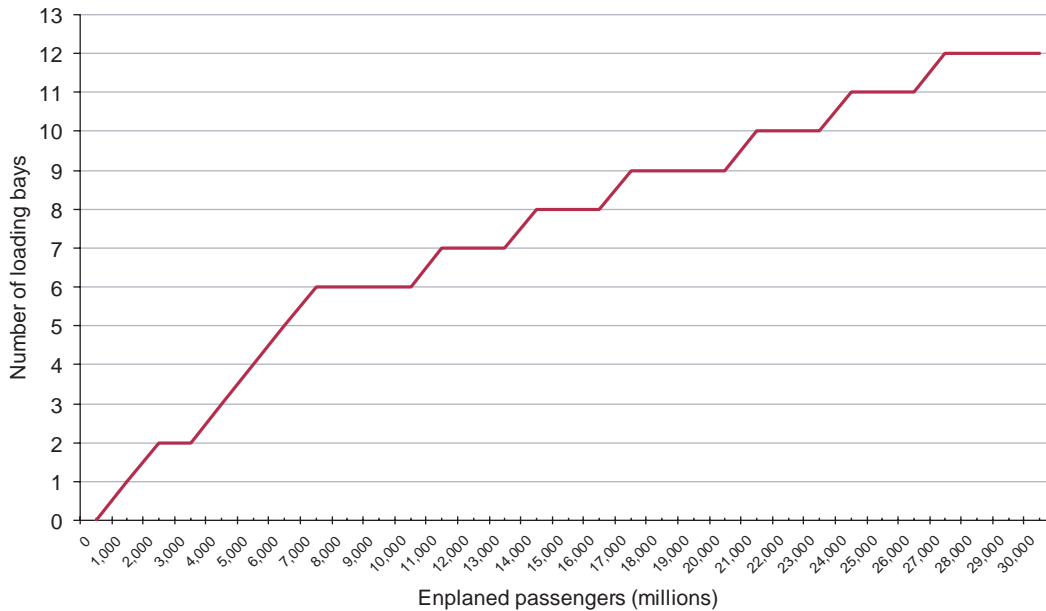

Source: LeighFisher.

**Figure 11-1. Loading dock requirements as a function of enplaned passengers.**

- A minimum of 4 feet of overhanging canopy to protect users and goods being unloaded from the elements. In cold climates, dock seals should be used at each loading bay. Alternatively, consideration could be given to enclosing the entire loading bay.
- A dock manager's room or booth in a location from which the entire dock area is in view and the entrance and exit from the building can be controlled. Security cameras may serve as a backup.
- Loading docks located so that vehicles will not be driven into or parked under the building to protect the building from an explosion. If this is not possible, the service area should be hardened for blast. TSA security representatives should be consulted on the security requirements for concession deliveries and loading docks.
- Docks separated by at least 50 feet in all directions from utility rooms, utility mains, and service entrances, including electrical, telephone/data, fire detection/alarm systems, fire suppression water mains, cooling and heating mains, fuel storage areas, and the like.
- A means to reduce outside debris from filtering into the building. Maintaining a negative air pressure on the docks and positive air pressure in the terminal building will help reduce infiltration of dust, dirt, and odors and enhance indoor environmental quality.
- In colder climates, radiant heating systems in the loading dock area to maintain a reasonable temperature range in the work area while conserving energy.

### 11.1.3 Loading Area Storage

In the loading area, short-term pre-security storage (in the event that screening becomes backed up) may be required, as well as short-term storage for screened goods. The availability of storage rooms is often driven by space availability. Less storage availability means more frequent deliveries to concessions, thereby increasing costs.

## 11.2 Security Screening of Goods

Retail goods may be subject to x-ray screening before they are accepted for storage. The equipment used must be of a type approved by the TSA and must be installed in accordance with the applicable regulations, including the provision of adequate space. To this end, the truck bays may

be secured for the delivery of supplies and stock to the concessionaires and the removal of waste. Security screening checkpoints may be located at the airport security perimeter, at the truck bays to screen inbound concession goods, or further downstream in the terminal building. To best accommodate the size of typical loads associated with terminal retail products, an oversized x-ray machine is required. In addition, redundancy in the security screening equipment is recommended to accommodate peak volumes and to provide backup in the event of mechanical failures or maintenance requirements. Of the airport operators surveyed for this research project, 31% indicated that they had a separate screening checkpoint for concession goods and employees.



In designing a new terminal, consideration should be given to providing sufficient area to install security screening devices adjacent to the truck bays with secure airside service corridors from that point. The current practice at many airports of screening concession goods well inside the terminal on the departures or arrivals level means that unscreened goods are being transported through the pre-security areas in the terminal.

### 11.3 Concession Storage Facilities



Concession storage is typically accommodated in a combination of storage space in or near the concession unit, if space is available, and storage space in lower levels of the terminal adjacent to the truck bays. Concession storage space near the truck bays will hold incoming products and inventory for restaurants and retail stores. Where storage for concessions must be remote from the units, there should be access from the concession units via a back-of-house service corridor to the interim storage area, if possible (in expanded or modified terminals this is typically not possible). The different types of storage space typically include the following:

- **Climate-controlled general storage.** Provides space for bulk, rack, and bin storage, aisle space, unpacking space, and office space.
- **Refrigerated storage.** Preserves the quality of perishable goods and duty free products that require refrigeration. Includes freeze and chill space, processing facilities, and mechanical areas.
- **Controlled humidity storage.** Similar to general storage, except that these storage units are constructed with vapor barriers and contain humidity control equipment to maintain humidity at desired levels.

Many older terminals operate with less-than-desirable storage space and this shortage imposes additional costs on the concessionaires, as frequent deliveries for restocking are required.

The need for storage space varies by concession category. Expressed as a percentage of the contiguous leasable concession space, the storage ratios range from 10% for services to 30% for duty free, as summarized in Table 11-2.



Charging concessionaires for support space would help ensure that the space is effectively used. At airports where concessionaires are not charged for storage space, or where nominal amounts are charged, greater demand and less efficiency in the use of this space will result. Of the airport operators surveyed, 48% indicated that they charge a separate rent for storage space.

Storage rooms are used to hold “incoming” products and inventory for restaurants and retail stores, as well as goods and supplies for terminal operations and other services, from the time of delivery until the concessionaire is available to pick up the goods and transport them to their destination in the terminal. Storage rooms should be located by docks as well as by concession units. Where storage rooms for concessions must be remote from the units, access from the units should be provided via a back-of-house service corridor to the interim storage area.

Storage space is often designed with higher bays to take advantage of vertical storage. At large airports, where the volume of goods can be substantial, the spaces need to be large enough to

**Table 11-2. Storage space requirements by concession category.**

Category	Storage (percent of leasable concession space)
Duty free	30%
Food and beverage	15%
Convenience retail	20%
Specialty retail	15%
Services	10%

Source: LeighFisher.



provide circulation space and space for material handling equipment, such as forklift trucks. Designs for storage areas should anticipate the loads of stored materials and associated handling equipment, typically 250 pounds per square foot. Racking in seismic areas must be stronger and better braced.

Some storage areas may require power and utilities, and others may be simple storage areas. Depending on the goods being stored and the handling equipment required, well-distributed power and utility lines throughout the space may be required. Storage spaces typically include one floor drain for every two bays of storage, as well as sand and oil traps on waste lines.

Food storage areas typically provide for dedicated general dry goods storage, ventilated storage, and refrigerator and freezer storage (premanufactured modular units with integrated shelving). A load of 150 pounds per square foot is typical in these areas.

## 11.4 Servicing Routes and Devices

### 11.4.1 Service Corridors

Service corridors should allow for the transport of goods and people between docks, vertical transport systems, storage areas, service areas, and concession units. Many older terminals do not have service corridors. In a new facility, however, every attempt should be made to create complete back-of-house support facilities, including service corridors and service elevators. To ensure the accommodation of service corridors, such requirements should be taken into account at the preliminary design phase for a terminal; typically, a champion at the airport is required to protect these elements as the design develops.

Service corridors are subject to significant wear and tear, with goods, carts, and garbage bins being moved regularly. They typically have hardened concrete, quarry tile, or epoxy floors; concrete block or drywall walls with epoxy paint finish and protective bumper rails; easily cleanable ceilings; and double doors, center hinged, with a total opening of 6 feet to 7 feet, with protective bumper plates.

### 11.4.2 Elevators

The interior of freight elevators should be stainless steel or some other corrosion-resistant material. In addition to the daily delivery/removal service for concession units, these elevators provide for the movement of major pieces of equipment needed for terminal maintenance. In new terminals, one of the freight elevators should be capable of accommodating an automobile or equipment to support product advertising and promotions.





## 11.5 Use of Centralized Third-Party Logistics Providers

Centralized logistics providers offer cross docking or redistribution services. In providing cross docking services, the logistics provider takes delivery of goods in a central commissary or receiving area and dispatches the goods to the concession units or restaurants on a schedule that recognizes the storage and use patterns of the concession. This service might also include security screening. In providing redistribution services, the concessionaires place orders with the logistics provider, which may consolidate such purchase orders. The logistics provider receives the goods at the central commissary, makes sure that the goods undergo security screening, breaks out and repackages the goods if necessary, and delivers the goods to the concessionaires on an agreed-upon schedule.

### 11.5.1 Current Use of Centralized Logistics

Centralized logistics providers are used by a small number of airport operators, but this use may increase if security regulations become more stringent. The airports where centralized logistics providers are known to be used are summarized in Table 11-3. One of the providers indicated that it serves two other airports, but those were not identified.

All the airports identified are large hubs with one exception, Pittsburgh International Airport, which was a large hub at the time the airport operator and Third-Party Developer made the decision to use a centralized logistics provider.

### 11.5.2 Reasons to Use Centralized Logistics Providers

In addition to airport size, the reasons that airport operators choose a centralized logistics approach include enhanced security screening of deliveries, reduced congestion at loading docks due to active management by the centralized logistics provider, improved use of limited in-terminal concession storage, and efficiency in managing deliveries and product distribution for numerous small concessionaires.

The TSA's enhanced security requirements mean that concessionaires must be able to demonstrate supply chain control, that is, that control of delivered goods is controlled from the time deliveries are made to the time they are delivered and secured in the concessionaire's controlled post-security spaces. Airside deliveries must be made by screened and badged personnel. Older practices of "key drops" at the loading docks are no longer acceptable.

**Table 11-3. Airports where centralized logistics providers are used.**

Airport	2009 Enplaned Passengers	Hub Size
Baltimore/Washington Thurgood Marshall Airport	10,338,950	Large
Detroit Metro Airport	15,211,402	Large
Minneapolis - St. Paul International Airport	15,551,206	Large
New York LaGuardia Airport	11,084,300	Large
Philadelphia International Airport	15,002,961	Large
Pittsburgh International Airport	3,956,842	Medium
Reagan Washington National Airport	8,490,288	Large
Toronto Pearson International Airport	16,167,415	Large
Washington Dulles International Airport	11,131,406	Large

Source: LeighFisher using data from the airport surveys conducted for ACRP Project 01-11.



At large hub airports, particularly those with older terminals, a combination of the lack of concession storage space in the terminals and high volumes of food and retail goods being consumed means that individual deliveries to concessionaires become a logistical problem, particularly at the loading docks. Delays can mean that concessionaire staff are spending hours per day at the loading docks waiting for deliveries or managing frequent deliveries.

On the whole, concessionaires often do not like centralized logistics providers because of increased direct costs. Savings in terms of concessionaire employee time, for example, may offset these direct costs, but they are less tangible and more difficult to quantify.

### 11.5.3 Centralized Logistics Case Studies

To provide an overview of some of the scale and effect of centralized logistics, three brief case studies are provided below: Minneapolis-St. Paul International, Reagan Washington National, and Washington Dulles International Airports.

#### *Minneapolis-St. Paul International Airport*

The operator of Minneapolis-St. Paul International Airport introduced centralized logistics at the time of a major concession expansion within an existing terminal complex. At that time, tenant vehicles and delivery trucks were competing for limited dock space, and concession deliveries were commingling with passengers in congested corridors. The airport operator was also interested in ensuring the security of deliveries.

A logistics provider was retained to do the following:

- Create a centralized command and control area by bringing all deliveries through a single entry point within a very scheduled and managed environment.
- Relieve congestion within the terminals by consolidating deliveries, which in turn reduced the number of delivery carts and personnel.
- Enhance security through supply chain management. One reported result of the use of a centralized logistics provider was the cancellation of 150 supplier identification badges.
- Reduce vehicle traffic, including traffic related to airside deliveries. Over 200 weekly delivery trucks were reportedly replaced with five logistics provider trucks.
- Enable expansion of the concession program without expanding storage and delivery systems in the terminal.

#### *Reagan Washington National Airport*

At Reagan Washington National Airport, deliveries for retail concessions are undertaken on a cross-dock basis by a logistics provider contracted by the concession program leasing manager. The logistics provider occupies a 5,000 square foot warehouse/distribution facility located on the airport grounds. This facility is divided among the retail tenants, and space is allocated based on the total square footage of each store.

The retail tenants' goods are received from the vendors, sorted, placed on the provider's vehicles, and delivered to the retail concessionaires. There are no retail storage spaces in the terminal.

The logistics firm does not handle food service deliveries, which are brought directly to the loading docks at the terminal building. The food service deliveries are screened at the loading dock and then handled directly by the concessionaires.

#### *Washington Dulles International Airport*

At Washington Dulles International Airport, food service concession deliveries are handled by a logistics provider under contract to the concession leasing manager. The service provided is a cross-dock service using a 7,500-square foot commissary on the airport grounds. Goods

are received from the vendors and sorted; pallet deliveries are broken down and deliveries are made by the provider directly to the concourses. With the exception of a bookstore, the logistics provider does not handle retail deliveries, which are handled directly by the concessionaires.

### 11.5.4 Costs of Centralized Logistics

Table 11-4 provides the estimated logistics charge as a percent of sales. Each airport is unique, but the data from the three case study airports are probably indicative of the range of charges for centralized logistics providers.

While each airport is unique in terms of volume, layout, and costs, Minneapolis-St. Paul International Airport provides a good indicator of costs. Food and beverage concessionaires are charged 0.50% of sales, and retail tenants are charged 0.33% of sales.

### 11.5.5 Implementing Centralized Logistics

Although concessionaires are typically not supportive of centralized logistics because of the extra cost involved, implementation is often driven by a significant change in operations such as a terminal redevelopment resulting in a substantial increase in airside concessions, possibly without a corresponding increase in concession storage or service corridors, security requirements that can no longer be easily achieved by the individual concessionaires, and congestion levels at the loading docks that are causing gross inefficiencies or failure to deliver goods to concessionaires. This is particularly important where perishables foodstuffs are involved.

Even with these triggering events, every attempt should be made to bring the concessionaires on board with the implementation of a centralized logistics system. Concessionaires are naturally resistant to increases in operating costs and will need to understand the benefits as well as the costs of implementing such a system.

## 11.6 Waste Collection, Recycling, and Removal

### 11.6.1 Airport Waste Characteristics

Airport waste is generated by passenger services onboard aircraft; airport offices, shops, restaurants, restrooms, and flight kitchens; cargo operations, maintenance areas, and hangars; and landscaping, construction, and demolition. Each of these areas creates distinct waste streams. The three



**Table 11-4. Examples of charges for centralized logistics as percent of sales.**

Airport	Logistics Charge (as percent of sales)
<b>Minneapolis - St. Paul International Airport</b>	
Food	0.50%
Retail	0.33%
<b>Reagan Washington National Airport</b>	
Food	–
Retail	1.26%
<b>Washington Dulles International Airport</b>	
Food	1.13%
Retail	–

Sources: Minneapolis charges, *Airport Revenue News*, July 2008. Washington airports charges calculated by LeighFisher from the dollar value of the charge in 2009 divided by 2008 sales.

passenger-related waste streams (airlines, airport tenants, and the airport operator) are illustrated on Figure 11-2 and described in more detail below.

### 11.6.2 Airline Waste

Airline waste includes waste from passenger aircraft, ticketing counters, and gate areas. This waste typically includes food and drink containers, uneaten food, newspapers, magazines, computer printouts, and other paper generated at ticketing counters. The characteristics and quantities of waste generated on an aircraft vary by length of flight and by airline. Low-cost carriers, such as Southwest Airlines, do not use flight-catering services because they do not offer in-flight meals. Because these airlines do not generate in-flight waste associated with meal service, most of their waste comes from beverage containers and small snack wrappers served by the airline and waste related to items brought onboard by passengers, including food, newspapers, and magazines. Historically, in-flight meals were provided by the larger legacy carriers. However, financial pressures on the airline industry have prompted cost-saving measures among many legacy carriers, including the elimination of free meal service on most domestic flights (at least in coach). Eliminating food service means that the waste generated on domestic legacy carrier flights resembles the waste generated on low-cost carrier flights. Legacy carriers operating international flights, on the other hand, have more extensive in-flight services and consequently greater volumes of waste.

### 11.6.3 Retail and Food and Beverage Waste

Retail and food and beverage waste includes cardboard boxes, paper and plastic packaging, food scraps, and food wrappers disposed of in shops, restaurant kitchens, and airport dining areas. Waste material also includes aluminum, plastic, and glass containers.

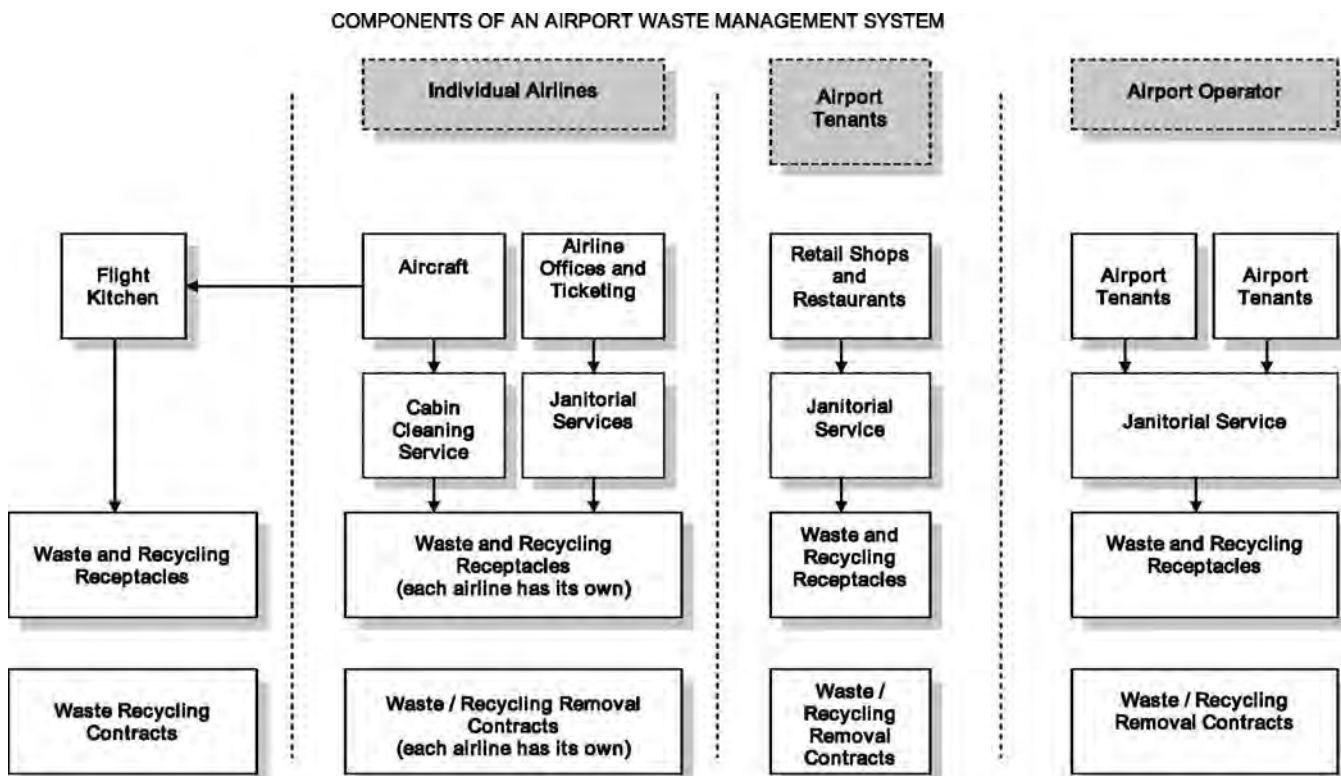

Source: Atkin, Hershkowitz, and Hoover 2006.

**Figure 11-2.** Components of an airport waste management system.

### 11.6.4 Terminal Public Area Waste

Terminal public area waste includes food and drink containers, food scraps, newspapers, magazines, plastic wrappers, restroom trash, and other waste generated in the public areas of the passenger terminal. In addition, the waste includes copier paper, toner cartridges, and discarded office supplies used in airport offices.

### 11.6.5 Typical Airport Solid Waste Sources, Composition, and Recycling

Figure 11-3 provides a breakdown of the types of waste generated by airlines and retail and restaurant tenants and in public areas of the terminal building at five major U.S. airports. These five airports serve 10% of U.S. airline passengers. The figure indicates that nearly three-quarters of the materials in the waste streams of these airports consist of potentially recyclable or compostable materials. Recyclable or compostable materials include paper products, plastics, aluminum, glass, food waste, and some food-contaminated packaging. The typical U.S. average for airport waste recycling is 30%. Many airport operators have established a future recycling target of up to 60%.

Furthermore, based on the data provided by the operators of 10 major U.S. airports, it is estimated that airline waste accounts for 47% of the waste stream at a typical airport, retail tenants generate 14%, food and beverage tenants generate 27%, and terminal public areas account for 12% of the total waste at these airports, as illustrated in Figure 11-4.

### 11.6.6 Waste Removal



Several types of waste accumulate throughout the airport and require different types of attention. Waste needs to be collected throughout the day as area bins fill and are transported to waste holding rooms or dumpsters via service corridors. Wet waste is generated from the food and beverage concessions. Trash is generated in all areas of the terminal—retail concessions, offices, restaurants, holdrooms, ticket counters, and so forth. Recyclables are generated from the restaurants and any vending areas and primarily consist of glass and aluminum. Recyclable paper is generated in retail units, passenger holdrooms, and office areas. Trash and recyclables need to be held in separate containers from the wet waste. All waste is transported, as needed, to the waste holding areas, where it is loaded into compactors or other storage containers. Recyclables are not typically com-

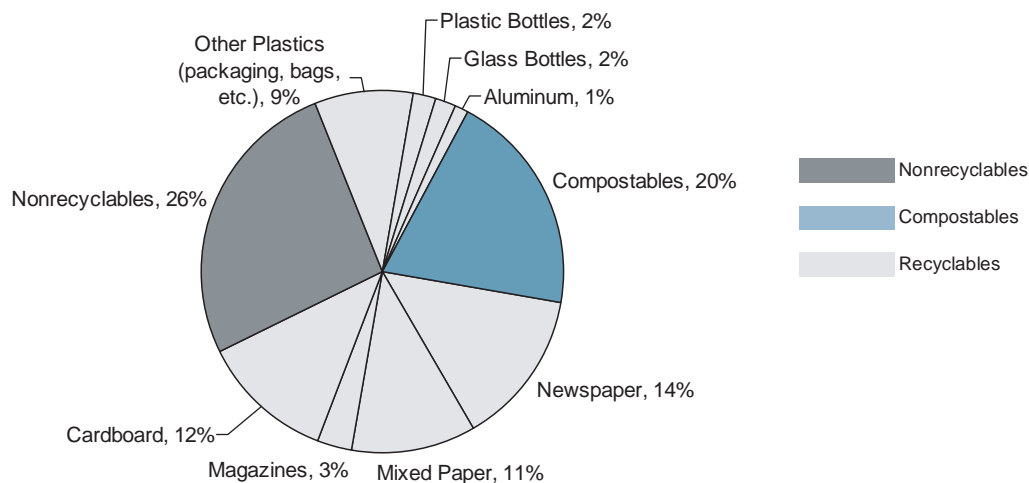

Source: Atkin, Hershkowitz, and Hoover 2006.

**Figure 11-3.** Waste composition estimate based on data from five major airports.

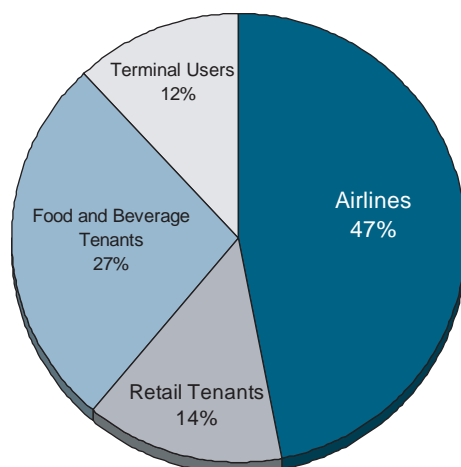

Source: Atkin, Hershkowitz, and Hoover 2006.

**Figure 11-4. Airport waste generation source streams.**

pacted, with the exception of cardboard when the volume justifies. Hazardous waste, such as fluorescent light tubes, oils, paints, and the like, is held in secure storage for pickup and removal.

Typically, two compactors are provided: one refrigerated compactor for wet waste and one for cardboard. A 28-cubic-yard compactor requires approximately 640 square feet of floor space.

Airport terminals resemble shopping malls, with public areas, shops, and restaurants. Similar to shopping center recycling programs, airport terminal programs can benefit from addressing recycling when a new terminal is designed. For example, Minnesota's Mall of America was designed with recycling in mind. An innovative chute and cart system, designed into the building, moves trash and recyclables through the mall. Mall officials estimate that it saves \$200,000 per year in waste management labor costs. It is recommended that terminal plans be designed to include space for recyclable storage, space and appropriate electrical service for balers or compactors, and easy access for vendors. Forethought during terminal design would also improve recycling activities at an airport.

### 11.6.7 Trash Rooms

Trash rooms are used to store outgoing trash, wet waste, and recyclables collected in the terminal throughout the day. Trash rooms—particularly for compactors and recyclables—should be located near the loading docks for easy access by refuse collectors. Areas should be hose washable from floor to ceiling and should typically include hardened concrete floors with metal “wear” plates for compactor/container runners (where applicable), concrete block walls with epoxy paint finish, and easily cleanable ceilings.

Trash rooms should be large enough to accommodate the trash handling equipment required and to provide storage for packaged trash generated during a 3-day period. Space should be provided for sorting paper, glass, and metals for recycling. Airports that have trash containers that are picked up by vendors should have at least one loading bay for the trash container.



### 11.6.8 Waste Amounts and Recycling

The total amounts of waste generated at medium and large hub airports can be large. Table 11-5 provides a rule of thumb for waste volumes generated at airports, and Table 11-6 provides

**Table 11-5. Average waste generation per 1,000 enplaned passengers.**

Source	Waste (cubic yards per 1,000 enplaned passengers)
Food and Beverage	1.13
Retail	0.18
Office, etc.	0.68
Total	1.99

Source: LeighFisher.

indicative weights per 1,000 enplaned passengers. A terminal accommodating 5 million annual enplaned passengers will typically generate approximately 19 cubic yards of waste per day, of which 6 cubic yards is recyclable at today's recycling average. The 19 cubic yards of waste weighs approximately 10,000 pounds.

High passenger traffic levels at larger airports make recycling of even part of the waste stream worthwhile. The operator of Seattle-Tacoma International Airport reports that it recycles 120 tons per year of coffee grounds alone.

Table 11-6 also presents typical recycling percentages by waste material based on a study of five airports published by the Natural Resources Defense Council (Atkin, Hershkowitz, and Hoover 2006). The table also provides target percentages that reflect what the authors of the report deemed to be achievable targets with a strong recycling program.



Opportunities exist for innovation in diverting waste streams. The Port of Seattle worked with concessionaires at Seattle-Tacoma International Airport to divert unused food that might otherwise go to waste to food banks. Twelve tons of food are diverted to food banks. The Port of Seattle also uses financial incentives to reduce waste at Seattle-Tacoma International Airport.

**Table 11-6. Approximate types and weights of airport-generated waste with average and target recycling levels.**

Material	Waste (pounds per 1,000 enplaned passengers)	Percent Recycled	Target Recycled
Aluminum	2	25%	50%
Cardboard	413	30%	60%
Newspaper	18	31%	61%
Office Paper	113	30%	60%
Glass	3	27%	55%
Plastic Containers	2	33%	67%
Plastic Films	187	30%	60%
Food Waste	38	30%	60%
Total	776	30%	60%

Source: Atkin, Hershkowitz, and Hoover 2006.



Concessionaires and other tenants use an electronic key cart to dump trash and are charged on a per use basis.

Other examples of airports with well-developed recycling programs include Salt Lake City International, Baltimore/Washington International Thurgood Marshall, and San Diego International Airports.

## 11.7 Sustainability

Airport policymakers are placing increased importance on sustainability in airport concession development. Sustainability practices at airports go beyond recycling and may include requirements for the following:

- Composting food waste
- Using recycled materials in construction
- Prohibiting the use of Styrofoam in packaging
- Using energy efficiency standards for concession development
- Using energy efficiency standards for concession operations
- Using or adopting the Leadership in Energy and Environmental Design (LEED) green building rating system created by the U.S. Green Building Council, which provides voluntary guidelines for developing high-performance, sustainable buildings
- Monitoring and reporting energy and water consumption
- Using sustainable cleaning products

The survey undertaken for this research project asked airport operators whether their various sustainability actions were required or encouraged. Figure 11-5 summarizes the overall results from the reporting airports, including all hub sizes. Airport encouragement or requirement of sustainability actions increases with overall passenger volume. Of the large hub airports, 76% were encouraged or required to undertake sustainability actions. This percentage declined to 58% at medium hub airports and 37% at small hub airports.

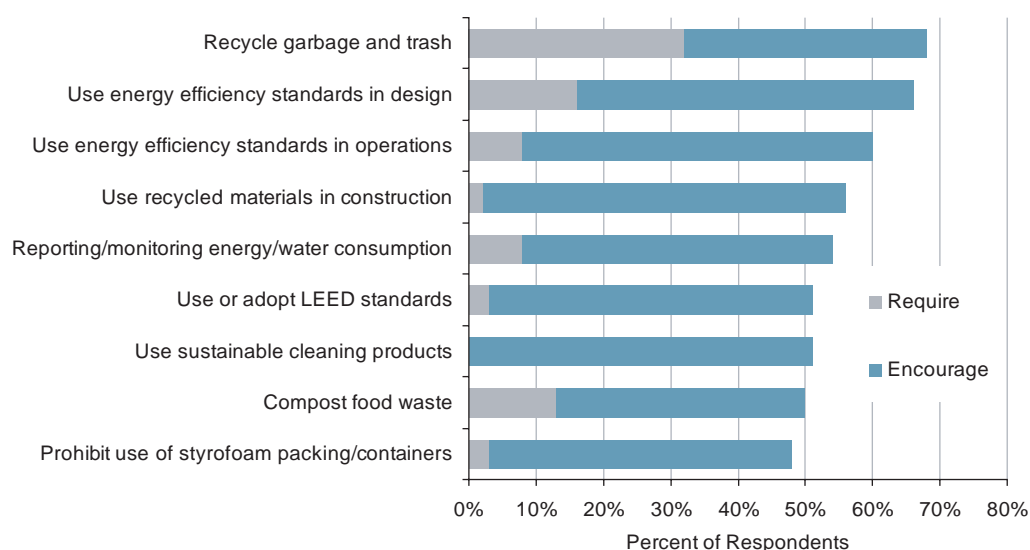

Source: LeighFisher using data from the airport surveys conducted for ACRP Project 01-11.

**Figure 11-5. Reported levels of encouraged or required sustainability actions by concessionaires at airports.**



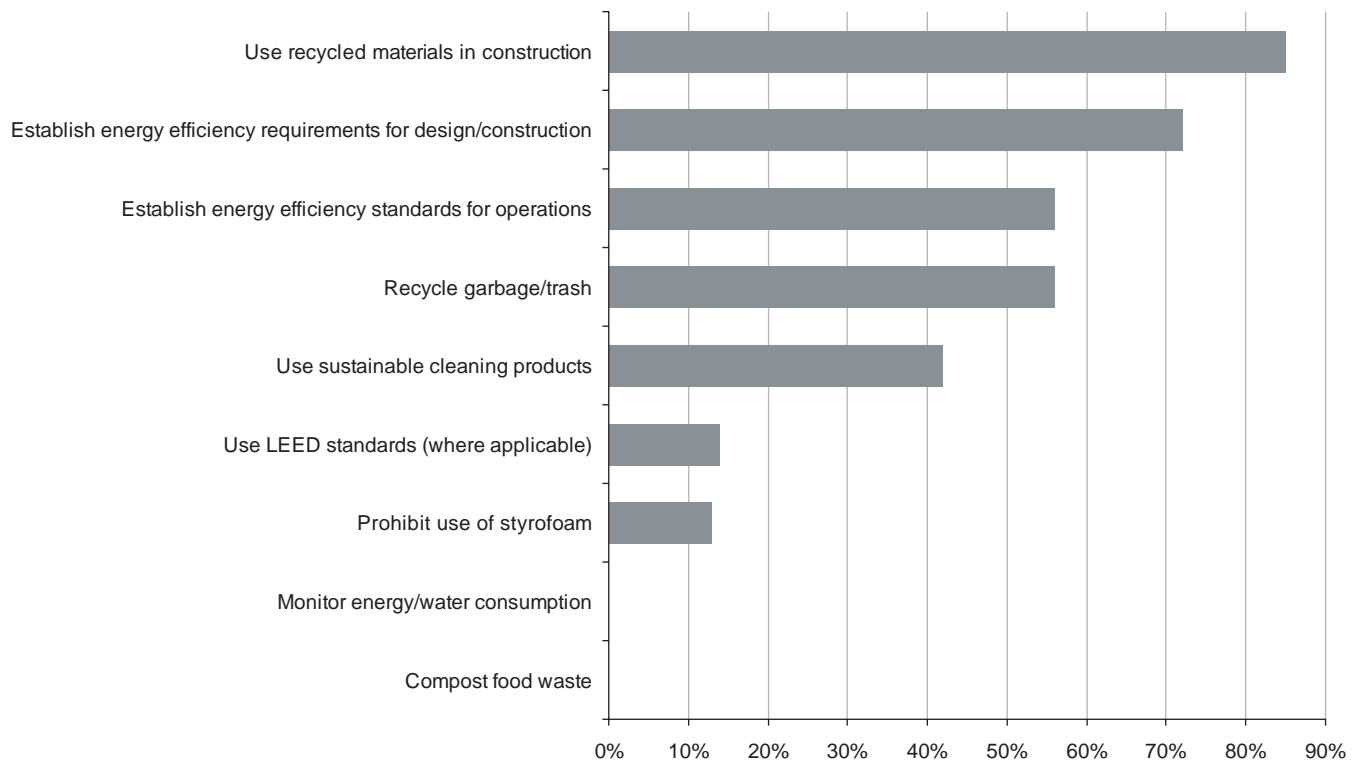

Source: LeighFisher using data from the airport surveys conducted for ACRP Project 01-11.

**Figure 11-6. Sustainability measures adopted by reporting concessionaires.**

Concessionaires have also adopted and incorporated sustainability practices into their concession developments and operations. These practices are similar to those practices required or encouraged by airport operators, but with a different emphasis. For example, as Figure 11-6 illustrates, although very few airport operators require the use of recycled materials in construction, almost all the concessionaires report that such use is their corporate policy.



Many airport operators are incorporating LEED standards in their new terminal construction programs, but very few are requiring it of their concessionaire tenants. This is true, in part, because LEED criteria for retail and food units are less well developed than LEED criteria for buildings and, in part, because the concessions are all contained within the building envelope of the airport so there is less impact from concessionaires.

Importantly, although concessionaires may not be required to be LEED-compliant themselves, their construction and maintenance actions may affect the airport operator's ability to have the terminal certified as LEED-compliant. Concessionaire construction standards, debris management, indoor air quality management and maintenance standards, and so forth, can affect the airport's certification.



If the airport operator intends for its tenants to be LEED compliant or to ensure that concessionaire construction actions do not impede the LEED certification of the terminal, requirements should be detailed in the lease agreements, along with processes to ensure compliance. LEED certification of a building also includes obligations with respect to recycling and other operational requirements. These obligations should be passed through to the concessionaires in their leases.

## 11.8 Food Preparation

The trend at airports has been to prepare food within concession units, in sight of passengers. In-unit cooking requires venting, natural gas service, water, sewer, and electrical service. Airport operators that have moved to fresh food preparation in units have seen significant increases in sales and customer satisfaction.

In-unit cooking is not possible at all locations. Some food types are prepared in advance, such as salads, soups, and sandwiches, and some are prepared in a commissary located back-of-house or even off the airport property. These foods are the cornerstone of “grab and go” operations. A significant amount of hot food is prepared offsite and reheated with a TurboChef or other ventless oven, including microwave ovens. This approach is particularly useful in “dry concourses” that do not have gas, water, or sewer connections.





## CHAPTER 12

# Capital Investment

This chapter presents an overview of concession-related capital investment and discusses the following:

- Cost of building on the airport
- Investment relative to sales
- Midterm investment
- Design guidelines and standards
- Permitting and monitoring buildout

### 12.1 Cost of Building on the Airport



Building out concessions on an airport, whether retail or food and beverage, is typically more costly than constructing similar units in shopping centers. Security requirements and logistics make on-airport construction more costly. Construction in a new, unused terminal is similar to construction in shopping centers, but such opportunities are rare. More often than not, concession buildout is undertaken in an occupied terminal.

The average buildout cost data shown in Figures 12-1 and 12-2 are available from the surveys undertaken for this research project. For airports of all sizes, the cost of building out a full-service restaurant at an airport averaged \$421 per square foot, with quick-serve units averaging slightly less, at \$408 per square foot. Building out convenience retail and specialty retail units averaged \$307 and \$320 per square foot, respectively.

These numbers are averages, and, depending on local factors, in some markets, construction costs are considerably higher. About 10% of airports in the survey reported buildout costs for food and beverage units averaging \$500 per square foot or higher, with a few airports reporting average costs above \$600 per square foot. The actual cost of building out concession space almost always exceeds the minimum investment requirements contained in RFPs.

As indicated in Figure 12-2, the differences in average buildout costs at small, medium, and large hub airports are relatively small. The costs are basically independent of airport size and are mainly affected by the local construction market.

### 12.2 Investment Relative to Sales

The survey of concessionaires and subsequent follow-up oral interviews identified the cost of constructing improvements as a concern. After high minimum rents, development costs were cited as the next most important airport concession-related business consideration. Concessionaires

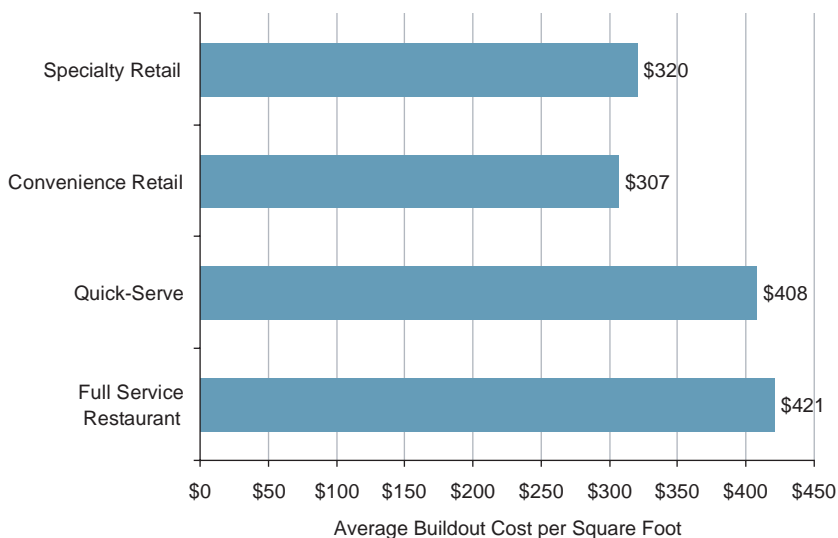

Source: LeighFisher using data from the airport surveys conducted for ACRP Project 01-11.

**Figure 12-1. Reported average annual space buildout costs per square foot by concession category—2009 dollars.**

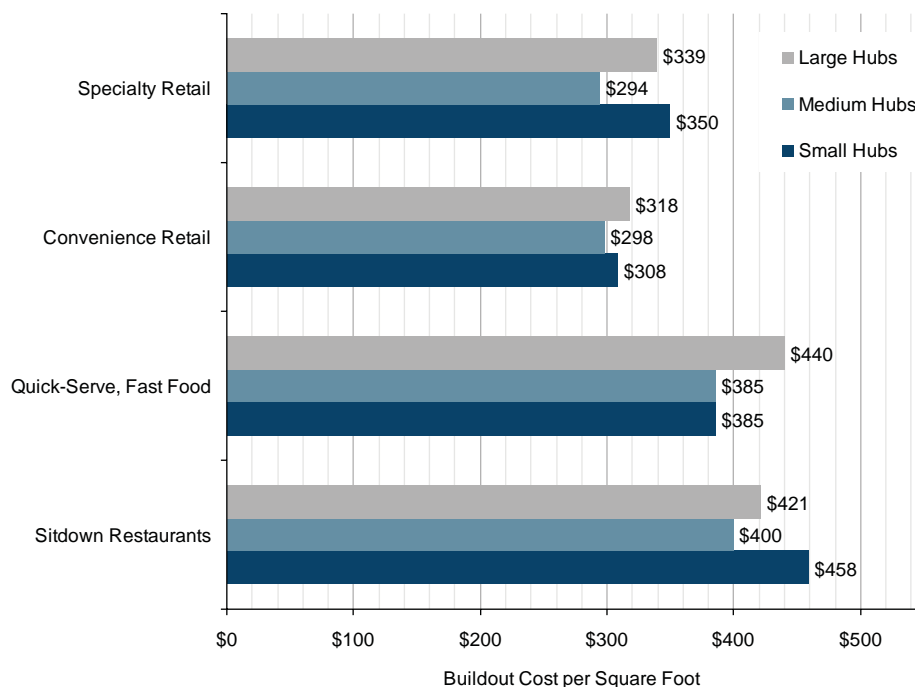

Source: LeighFisher using data from the airport surveys conducted for ACRP Project 01-11.

**Figure 12-2. Reported average buildout costs by concession category and hub size—2009 dollars.**

**Table 12-1. Business practices in need of change or improvement according to concessionaires (Issues ranked on a scale of 1 [least] to 5 [most]).**

	Business Practice	Weighted Average Rank
1	Minimum annual guarantees	4.3
2	Cost of constructing improvements	4.0
3	Length of term	3.9
4	Street pricing	3.6
5	Percentage rents	3.4
6	RFP processes	3.4
7	Design review processes	3.1
8	Performance standards in concession agreements	3.1
9	Lack of transparency in solicitation process	3.0
10	Midterm refurbishment requirements	2.9

Source: LeighFisher using data from the airport surveys conducted for ACRP Project 01-11.

cited generally increasing costs, arbitrary design review processes, and unreasonably high standards among factors contributing to the rise in concession development costs. Midterm refurbishment costs, discussed in Section 12.3, were not considered to be a major concern. Table 12-1 summarizes the business practices needing improvement as ranked by concessionaires responding to the survey conducted for this research project.

In most cases, concession development costs are a contractual commitment resulting from the procurement process. Typically, the airport operator sets a minimum investment cost per square foot, and concessionaires propose, among other things, a minimum investment amount. Minimum investment requirements included in RFPs typically understate the actual amount of investment that will be required.



The amount of investment proposed by a concessionaire will be based on the business opportunity and expected revenues. In discussions with concessionaires and experienced design consultants, two “rules of thumb” emerged that can help airport operators assess the ability of the concession opportunity to support the expected level of investment.

- 1. Sales at two times cost per square foot.** A general rule of thumb is that the first-year projected sales per square foot should be at least twice the expected cost per square foot of developing the space, assuming a typical length of term. This “rule” provides the sales volume necessary to produce the earnings required to support amortization of the investment. Where sales per square foot are expected to be high, higher investment amounts can be supported. Where sales per square foot are projected to be lower, the investment may not be viable and other considerations may be necessary, such as a longer agreement term. Where multiple spaces are included in a concession opportunity, spaces with high sales potential can be combined with spaces with lower sales potential to create a package that can support the required investment. Some concessionaires may require a higher sales-to-investment ratio.
- 2. Straight-line depreciation.** Another rule of thumb is that the annual straight-line investment (investment without interest divided by the number of years in the term of the agreement) divided by the annual expected sales should range between 2.5% and 4.0% of sales.

Each concessionaire has its own approach for determining the amount of investment it proposes. Investment can vary according to category (for example, food and beverage) and concept (for example, quick-serve), as well as the concessionaire’s own cost structure and development capabilities.



## 12.3 Midterm Investment

Airport food and retail units are high-traffic areas that can become shabby or out-of-date well before the end of the agreement term. For this reason, 80% of the operators of reporting airports indicated that a midterm refurbishment requirement is included in their agreements. Most airport operators use one of three methods to ensure that reserves are set aside by the concessionaires for midterm investment:

- **Dollar per square foot requirement.** The range of requirements reported by airport operators was \$50 to \$300 per square foot. Some agreements incorporate a cost of living escalator in the calculation.
- **Percentage of the initial capital investment.** Requirements are typically 15% to 20% of the initial capital investment. One airport operator reported identifying a minimum capital requirement of 50% of the initial capital investment in its concession RFPs.
- **Specified upgrades or changes.** This method involves defining the specific leasehold improvements that will be required midterm.

Other methods reported by airport operators included requiring midterm capital investment based on a percentage of sales, establishing the amount of midterm investment during agreement negotiation, and requiring the midterm investment amount to be identified by bidders at the proposal stage.



## 12.4 Design Guidelines and Standards

Many airport operators provide design guidelines and standards to be followed by concessionaires in their design and buildout. The objectives of these guidelines and standards are to ensure that life safety is protected, maintain a desired quality of materials and finishes, and bring the concession appearance in line with an overall architectural theme.

Design guidelines vary widely with respect to the appearance of the concessions, from very minimalist guidelines, which leave much of the look of the concession storefronts up to the concessionaires, to very strong guidelines, which create a single storefront design that must be used by all. The selection of a particular approach is usually determined by the airport operator's interest in creating a themed environment and by the terminal architect's interest in guiding the concession design to conform to the design of the terminal.

There are many examples of terminal architects working to minimize the effect of the concessions through the use of stringent design requirements for storefronts and signage. This approach can be in direct contradiction to the airport operator's goal of maximizing revenues and customer satisfaction; in such cases, the airport operator's concessions management department needs to be active in protecting its interests, which may be different from those of the terminal architect.

Tenant design standards tend to have a similar format from one airport to another. A typical list of information included in tenant design standards for food and beverage concessions is the following:

- General landlord criteria
  - Theme goals and guidelines
  - Tenant design responsibilities
  - Base building utilities and provisions
- Unit design standards
  - Limits of tenant space
  - Base building elements to be provided by airport operator



- Building elements to be provided by tenant
- Entrances and storefronts
- Merchandise display and fixtures
- Quality of tenant finishes
- Signage design standards
  - Sign types and materials
  - Blade signs
  - Signage at storefront entries and enclosures
  - Signage within tenant spaces
- Food and beverage criteria
  - General procedures and responsibilities
  - Tenant contractor check-in/access
  - Signage
  - Menu board
  - Food service and preparation requirements
- Submissions
  - Preliminary presentation
  - Final submissions
- Tenant construction criteria
  - General procedures and responsibilities
  - Tenant contractor check-in/access
  - Interruptions to operation of existing facilities
  - Floor loading and structural constraints

### 12.4.1 General Landlord Criteria

The general landlord criteria typically set the framework for tenant design. The airport operator's objectives for the concession program are described, the terminal architecture is illustrated, and the theme (if any) and associated color palettes are described and illustrated.

Theming can be used to provide overall cohesion to the concession program or to provide or enhance a sense of place. Theming is typically established by the terminal architect in consultation with airport management or by the concession planning team. Some locales, particularly those that are primarily tourist destinations, lend themselves to fairly strong theming, while others do not. The most beneficial stage in which to incorporate theming is early in the terminal design process, so that interaction between the individuals responsible for terminal design and concession theming can be a two-way dialogue.

### 12.4.2 Unit Design Standards

Unit design standards identify the division of responsibilities between the landlord and the concessionaire, including the provision of utilities. Tenant space is defined, and guidance is provided on how movable displays may be used. In the past, tenant design criteria typically required movable displays to remain within the leased space. More recently, there has been a shift at some airports to “soft” storefronts, in which the placement of movable displays in a defined area in front of the concession is permitted.



Variations exist from airport to airport in defining landlord and tenant responsibilities, but in the most common division of responsibilities the airport operator is responsible for common area passenger walkways including lighting, ceiling, flooring, walls, and heating, ventilation, and air conditioning (HVAC); basic demising walls between concessions; concrete slab floors; a structural grid ceiling; and utilities brought to the perimeter of the tenant space.



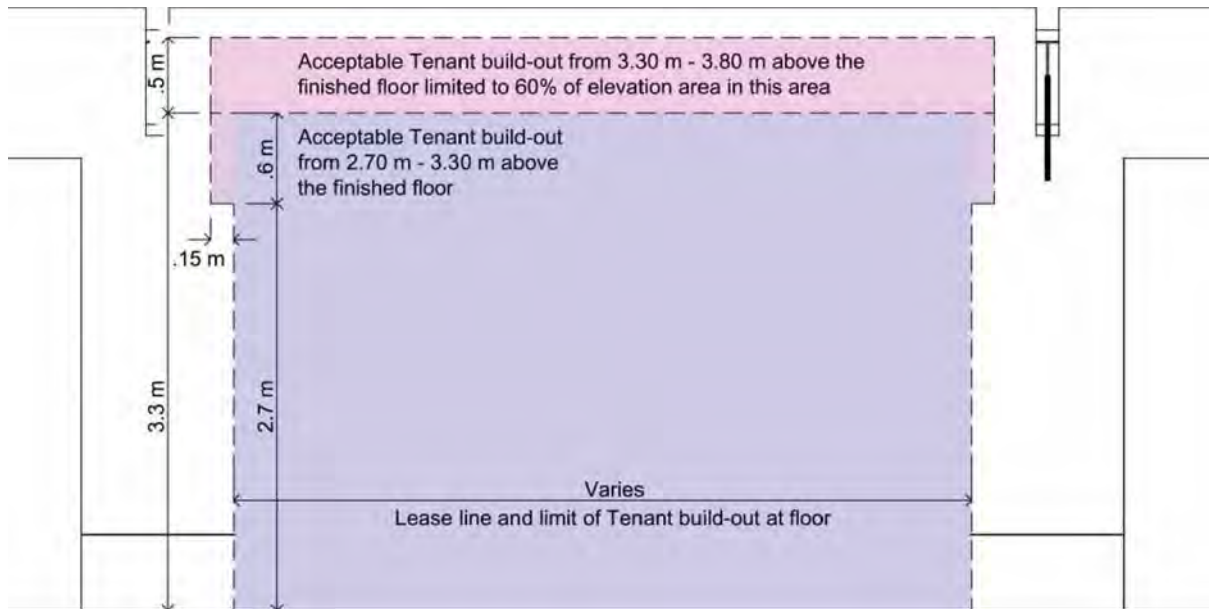

Source: Architectural Alliance and LeighFisher, "Terminal Planning, Design, and Construction, Norman Manley International Airport, Kingston, Jamaica 2005–2009," unpublished.

**Figure 12-4. Example buildout limits—elevation.**

- Layouts cater to passengers' limited time, with displays arranged to encourage impulse purchases
- Ease of browsing and speed of transactions are incorporated
- Displays do not interfere with egress from or access to the store
- Aisle widths are adequate for passengers with baggage or luggage carts and to accommodate disabled persons, particularly those in wheelchairs

Expectations with respect to fixtures and furnishings are also included in the unit design criteria.

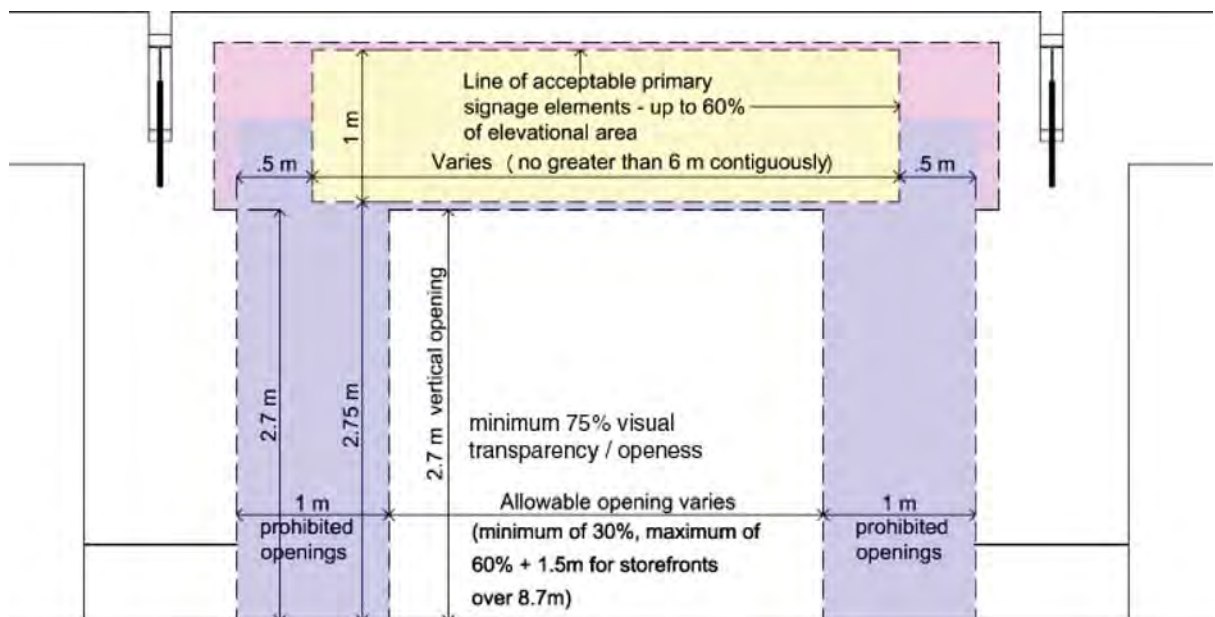

Source: Architectural Alliance and LeighFisher, "Terminal Planning, Design, and Construction, Norman Manley International Airport, Kingston, Jamaica 2005–2009," unpublished.

**Figure 12-5. Example storefront openings and signage areas—elevation.**

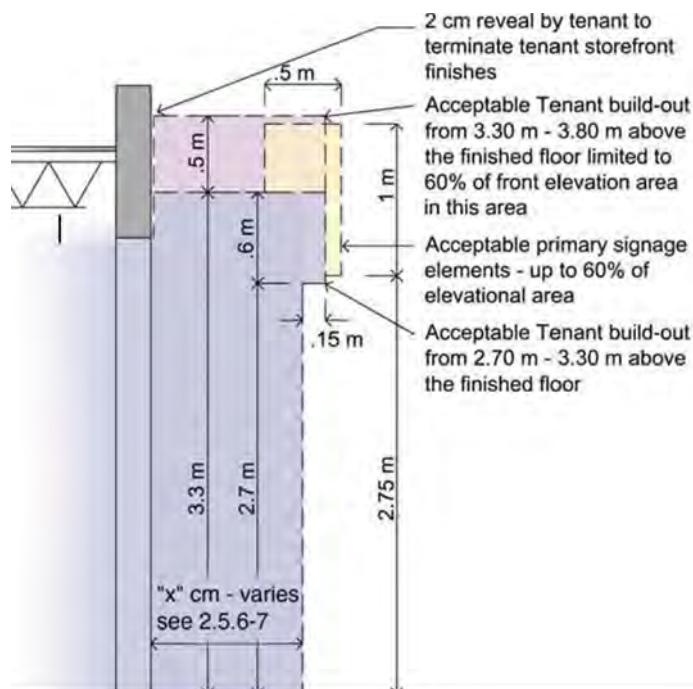

Source: Architectural Alliance and LeighFisher, "Terminal Planning, Design, and Construction, Norman Manley International Airport, Kingston, Jamaica 2005–2009," unpublished.

**Figure 12-6. Example buildout limits—section.**

Lighting is typically an important element of the unit design criteria. Concessionaires seek effect with their lighting, while the airport operator seeks both quality and compatibility with the terminal. Types of acceptable and unacceptable lighting are typically described in detail. If the airport operator has an energy reduction plan in place, the lighting criteria may require low energy fixtures and limits on overall lighting levels.

### 12.4.3 Signage Design Standards

Signage requires planning on a broad level before signage design standards are prepared. Questions to be answered include the following:

- Is the signage to be subdued or will it be an element of the color and impact of the terminal?
- Will signage be permitted to extend above the defined storefront? Under what conditions?
- Are the ceiling heights sufficient to allow the use of blade signs?
- How much individuality will be permitted in the shape and size of blade signs, if allowed?

Airport operators require the signage and related graphic designs to be fully integrated and coordinated with the overall terminal design concept and of a quality consistent with the terminal. To achieve this, the signage design criteria define acceptable sign types, for example:

- Light conductive, edge-lit glass
- Push-through illuminated letters
- Reverse channel-lit lettering
- Routed metal or stone
- Dimensional letters of metal, stone, or wood
- Etched on glass halo lit and/or surface illuminated signs
- Creative use of materials complementary to the facility theme





The signage criteria also define signage types that are discouraged or even disallowed:

- Plastic signs, such as injection molded or vacuum formed
- Backlit back-painted signs without a halo effect
- Painted or handwritten signs
- Foam letters or graphics
- Sand blasted wood or foam signs
- Neon letters
- Signs with replaceable letters
- Vacuum-formed or moving signs
- Generic signage, such as “News/Gifts” or “Pizza”
- Signs that do not convey permanence
- Bright flashing or strobe lighting
- Unprotected or exposed neon or other exposed light sources
- Menu or merchandise boards where price changeability is obvious
- Posted advertisements of sales and product lines

With respect to blade signs, the signage design criteria either require blade signs as part of the overall signage, or disallow them. For consistency, it is uncommon to leave the decision on blade signs to individual tenants. Also for consistency, the signage design criteria often indicate that the airport operator will provide the bracket and associated lighting for blade signs. Sketch drawings similar to that shown in Figure 12-7 are often provided.

Signage criteria may also require tenants to submit interior store signage for review and approval by the airport operator.

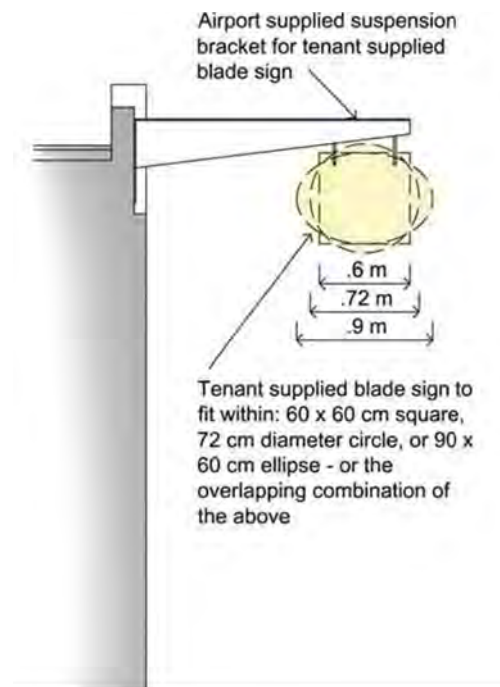

Source: Architectural Alliance and LeighFisher, "Terminal Planning, Design, and Construction, Norman Manley International Airport, Kingston, Jamaica 2005–2009," unpublished.

**Figure 12-7. Example blade sign criteria.**



### 12.4.4 Food and Beverage Criteria

Additional controls primarily related to health and safety issues are applied to food and beverage units, including the following requirements:

- Preparation of food using raw or partially prepared ingredients should be concealed from public view unless otherwise acceptable to the airport operator and other authorities having jurisdiction.
- Food service preparation should comply with all regulations of food and health safety authorities having jurisdiction.
- All odor-producing operations, products, and equipment are controlled. Exceptions are typically allowed for bakeries, coffee, etc.
- Exhaust systems be fabricated from stainless steel with an integral fire suppression system and compliant with National Fire Protection Association standards
- Where needed, the concessionaire provides (and maintains) individual grease traps.
- The finish on all walls in the sales area behind the counter is ceramic tile or equivalent.
- The concessionaire should install a waterproof membrane beneath tile floor in all kitchen, food preparation, dish washing, restroom, and bar locations.

The requirements for the public areas of food units are also spelled out, including the following requirements:

- Food service equipment, storage of goods and supplies, beverage dispensers, cash registers, and other equipment must be concealed from view as much as possible.
- Sneeze guards and/or tray slides, when required, be custom designed as an integral part of the front counter and be constructed of glass and stainless steel or brass.
- The materials for the counter facings must be durable and nonporous.

Airport operators typically require each food unit to have a menu board to inform customers about selection and price, and guidance is typically provided on the materials, and so forth for the menu board to avoid temporary or “handmade” signage.

### 12.4.5 Submissions

Ideally, the tenant design criteria are circulated with RFPs for concessions so that the prospective concessionaires are already generally familiar with the criteria at the proposal stage. To ensure that the tenant design standards are implemented, a series of submissions of the concessionaire’s designs are typically required—including a preliminary design, submissions at various stages of preparation (e.g., 30%, 60%, and 95%), and a submission of final 100% design drawings.

The preliminary design is submitted early in the design process to provide the airport operator’s design team an opportunity to comment on the design concept so that the team’s requirements can be incorporated into the concessionaire’s final construction drawings. This preliminary design submission typically includes the following:

- Storefront plan or food counter elevation and section (1:50 scale)
- Floor plan, furnishings plan, and reflected ceiling plan (1:50 scale)
- Storefront color rendering or photograph of typical storefront, including proposed signage
- Material sample board keyed to the drawings
- Confirmation that the floor loading will comply with building standards
- Proposed material and finish schedule with samples, including furnishings
- Electrical and mechanical load summary

The airport operator’s design team reviews the preliminary submission and accepts the submission, accepts the submission with changes to be incorporated, or rejects the submission.



The final submission is intended to consist of working drawings that incorporate comments received from the airport operator at the various submission stages. The final submission typically includes the following:

- Architectural drawings and specification requirements
  - Floor plans and reflected ceiling plan
  - Interior layout and design concept including merchandising layout(s)
  - Dimensions from lease lines and center lines of demising partitions, separating leaseholds, and floor materials
  - Storefront elevations and sections of food and bar counters
  - Storefront, food counters, and bar details
  - Interior elevations and details sufficient for construction
  - Interior finish schedule
  - Storefront, including emergency exit(s)
  - Signage and canopy elevations and sections including letter style and size, colors, materials, methods of illumination, color of illumination, wattage, mounting details, transformer location, and access
  - Specifications and identification of materials incorporated into the concessionaire’s design
  - A “sample board” illustrating proposed finish materials and colors, such as paint samples, floor and wall covering samples, illustrations of the proposed lighting, and so forth
  - Furnishings plan, specifications, and material and color selections, including samples
  - Specifications, if not on drawings
  - Any other special facilities or installations that may affect airport facilities such as vaults and kitchen equipment
  - Weight and location of heavy equipment such as safes, refrigeration equipment, showcases, and masonry facing materials
- Engineering drawings and specification requirements
  - Under floor electrical or plumbing plans (if any)
  - A dimensional location plan of all floor openings, if required
- Electrical drawings
  - Lighting, power, and communication layout including panel schedules
  - Installation and product specifications, either on the drawings or submitted separately
  - Load calculations indicating the total connected load, total demand load in kilowatts, and area of the space
  - Fire alarm connections to the existing fire alarm system
  - Emergency battery pack lighting and exit lighting
- Heating, ventilating, and air conditioning (HVAC) and plumbing drawings
  - Ductwork and diffuser layout for ventilation and air conditioning and location of room thermostat and makeup air requirement, complete with heat gain calculations and thermostat location
  - Plans or sketches showing location of the equipment complete with catalogue sheets, specifications, and sketches showing gas, water, and electrical consumption; horsepower; and other requirements

#### 12.4.6 Tenant Construction Criteria

In a terminal in operation, concessionaire buildout must be carefully managed and coordinated for safety and to minimize disruption to passenger flows. Even in a new terminal, concessionaire buildout must be managed to coordinate with terminal construction, which is typically occurring simultaneously. The construction criteria for the construction process and the concessionaire’s responsibilities must be clear and include the following:



- A requirement that no work commence until written approval of all plans has been provided by the airport operator, proof of insurance has been provided to the airport operator, and the lease agreement is in place.
- Identification of the access points and routes for construction materials to enter the terminal and be transferred to the concession buildout area.
- The hours of access for the movement of construction materials if movement through the public areas is required.
- The hours for any functions that could disrupt utilities.
- Restriction of storage of construction materials to the leased concession space and restrictions on the floor loading of stored materials.
- Assurance that no equipment, materials, or tools are in public areas of the airport. This was always important for passenger safety, but has become critical with enhanced security.
- A requirement preventing construction dust from being tracked onto the public area floor.

Where a concession program is being redeveloped as part of a major terminal reconstruction, it may be valuable to create a plan of construction operations to ensure that a minimum level of passenger service is provided. For example, a minimum level of service may require at least one food unit and one news unit per concourse to be open throughout the reconstruction. A plan of construction operations should include the schedule for each concession demolition and reconstruction, which the airport operator should review to ensure that the minimum level of service is maintained throughout the construction period.

## 12.5 Permitting and Monitoring Buildout

Obtaining a building permit is typically the responsibility of the concessionaire and the concessionaire's engineers/architects. Typically, concessionaire agreements require that all work conform to applicable codes, ordinances, and regulations governing such work—building, electrical, and plumbing. In addition, the concessionaire often has a specific obligation to ensure compliance with the Americans with Disabilities Act (ADA), including providing proof of an independent review of the design by an ADA expert and verifying that the completed installation complies with ADA.

### 12.5.1 Monitoring Buildout

Approval of tenant submittals is insufficient to ensure that concessions are built out as planned. The airport operator has the responsibility to monitor construction to verify that life safety issues are being addressed (gas and electrical connections and testing for example), that the materials installed comply with the approved submittals, and that the quality of construction is acceptable.

Some concessionaires are capable and diligent about using the construction materials and methods to which they have committed, while others may cut corners. To ensure that tenant buildout is to plan, daily inspections of the buildout are recommended. When concessionaires may endeavor to use substitute materials, their approach is often to create a “fait accompli” through rapid delivery and installation of the buildout.

At airports where a significant concession buildout program is under way, provision of a dedicated concession buildout supervisor is recommended for the period of concession buildout. The role of this supervisor is not only to ensure that the concessionaire(s) build to plan, but also to act as a liaison with the terminal design team to answer concessionaire questions during buildout and to troubleshoot.





## CHAPTER 13

# Managing the Concession Program

This chapter presents a discussion of concession program management practices. The effectiveness of terminal concession program management depends on many factors such as the size of the concession management staff; their training, background, and capabilities; the level of support of senior management; the clarity of the concession agreement(s); and the willingness and ability of the concessionaires to cooperate with the concession manager(s).

This chapter discusses the following topics in concession program management:

- Staffing requirements and qualifications
- Lease management systems
- Understanding the concession agreement
- Importance of comprehensive concession agreement files
- Interaction with concessionaires
- Marketing the concession program
- Organizing the concession staff
- Performance monitoring
- Reconcepting existing units
- Transition planning
- Airports with well-managed concession programs

### 13.1 Staffing Requirements and Qualifications



The number and experience of concession management staff are the primary determinants of the effectiveness of concession management. Staff capabilities should also be factored into the airport operator's choice of the concession management approach (see Chapter 8). The number of full-time equivalent (FTE) staff devoted to concession program management is often quite small, which restricts flexibility in choice of management approach and can result in unmonitored or under-monitored concession activities.

Airport survey results for this research showed that the number of concession staff, including clerical staff, averaged 7.2 FTEs at large hub airports, 3.4 FTEs at medium hub airports, and 2.0 FTEs at small hub airports. Third-Party Developers generally had considerably larger staffs managing projects—on average 12.4 FTEs—mostly at large hub airports. Airline staff managing concession programs averaged 6.0 FTEs, although the staff at one airline managed the concession program at more than one terminal. Average concession staff levels are shown in Figure 13-1.

Concession staff should have a good understanding of the business operations that are the basis for the terminal concession program and strong interpersonal skills for dealing with concessionaire management on issues as they arise. These issues include contract interpretation and enforcement, construction activities, security issues, periodic facility inspections, and other routine and special events.

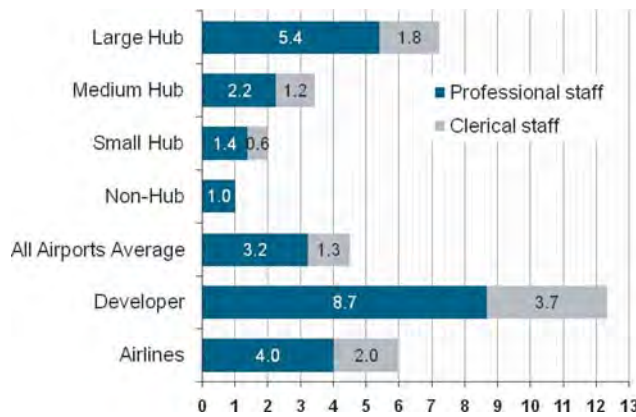

Source: LeighFisher using data from the airport surveys conducted for ACRP Project 01-11.

**Figure 13-1. Number of full-time equivalent professional and clerical staff dedicated to airport concession management and development.**

Although concession management skills can be, and often are, gradually acquired by inexperienced staff through on-the-job training, it is desirable for staff to have practical prior management experience in retail operations and/or concession management or property management at an airport, shopping mall, or other comparable venue. Individuals with prior retail management experience are often strong candidates for airport concession management positions.



Concessionaires often confirm that the airport operators with the best concession management practices are typically those with staff who understand the concession agreement and the concessionaires' business operations and needs and where there is a deep level of trust and open communication between the airport and the concessionaire's representatives.

## 13.2 Lease Management Systems

Lease management systems may be offered as pre-packaged software program modules available for sale, or customized software can be developed by a third-party vendor. Lease management systems can assist concession managers by providing ready access to important concession agreement data such as contract expiration dates, insurance and bond requirements, rents and concession fees, leasehold sizes and locations, and dates that key events are to occur, e.g., rent adjustments, exercise of options to extend the contract term, and so forth. In some cases, correspondence and activity statistics (e.g., monthly sales data) can be input and maintained in the lease management system for easy access and reference.

Lease management systems may also include modules or functions that can be used to generate billings, provide notices to tenants, analyze data, and produce management reports. It is important that airport operators who install a lease management system recognize the need to assign, and ensure proper training of, a staff member with overall responsibility for the system.

## 13.3 Understanding the Concession Agreement

Like all contract agreements, concession agreements set forth the obligations of the parties. Inherent in the airport concession management staff's duties is the ability to read, interpret, and enforce contract requirements. This is a critical component of successful concession program management.

An initial step in successful concession program management is to read and understand the concession agreements under which concessionaires operate. Uncertainties or questions regarding the interpretation of concession agreement provisions should be discussed with the author of the concession agreement and/or legal counsel for clarification of intent. While it is unlikely that all matters will be clearly addressed in the concession agreement, a good understanding of the provisions of the agreement and their intent helps reduce uncertainties and associated disputes. Lease summaries can minimize time spent researching common questions.

Concessionaires should also know their obligations under the concession agreement. The airport concession managers should meet with each of the concessionaire managers before the commencement of any new agreement and whenever new managers are assigned to discuss the provisions of the agreement so that both parties have a clear understanding of what is expected and required. Periodic, follow-up, one-on-one meetings are also recommended to discuss the effects of concession agreement requirements on business practices and results and to clarify any contractual uncertainties. If concession agreement provisions appear to be creating undue hardship on a concessionaire, concession management staff should bring this matter to the attention of senior management to consider whether the concession agreement should be amended or whether a future policy change is justified.

### 13.4 Importance of Comprehensive Concession Agreement Files



It is essential for airport concession management staff to maintain complete and comprehensive files for each concessionaire. In cases where a concessionaire has more than one concession agreement, it is often best to keep a separate file for each agreement for ease of reference and to reduce correspondence search time. Correspondence and other documents affecting more than one of a concessionaire's agreements should be duplicated in each separate concession agreement file or cross-referenced. Files should be clearly labeled and may be separated into different categories, such as the following:

- Concession agreement, including concessionaire's proposal and relevant board agenda items approving the award of the concession privileges and approving the concession agreement
- Construction-related documents
- Insurance certificates
- Guaranty instruments (e.g., surety bonds and letters of credit)
- Operating permits
- General correspondence and memoranda

Care should be taken to ensure the integrity and completeness of each tenant's files, particularly agreements, amendments, board agenda items, and correspondence related to the concession agreement. Files should be secured during nonbusiness hours, and responsibility for managing the files should be established. Documents that are deemed confidential should be clearly labeled as such and kept in a secured location separate from the concessionaire's other files. Sign-out cards should be used to keep track of anyone who has removed individual files.

Maintaining comprehensive concession agreement files is much easier than correcting erroneous information or rebuilding files that have not been kept up to date. Once the integrity of the files is compromised, considerably more effort will be required to restore the files than would have been required to maintain them in good order in the first place.

#### 13.4.1 Tickler Files

Tickler files of important dates in the concession agreements are an important part of keeping comprehensive files and critical to the concession management function. Tickler files are





used to keep track of concession agreement expiration dates, rent adjustment dates, dates that various reports or other submittals are due from the concessionaires, bond and insurance expiration dates, deadline dates for implementing term extensions, and other important dates affecting the concession agreements. Tickler files can help ensure that renewals are timely, that various contractually authorized or required functions are not overlooked, and that staff assignments can more easily be planned and distributed based on anticipated workload.

### 13.4.2 Concession Agreement Summaries

In addition to tickler files, summaries of important agreements that cover the most frequently used information in the agreements (e.g., expiration dates, leased premises sizes and locations, rents, and other key data) should be prepared prior to the beginning of the term of each concession agreement. The summary should be prepared by the staff member assigned to manage the concession agreement to acquaint the staff member with all of the terms and conditions contained in the agreement. It should be noted that lease management system software (see discussion above) can be effectively used to automate the tickler file and lease summary functions.



## 13.5 Interaction with Concessionaires

Managing the concession program requires frequent interaction between the concession and the concessionaires. The relationship between the airport operator and the concessionaires should be viewed as a partnership in which each party stands to profit from working together. By understanding each other's business needs and working together, both parties will have the best opportunity for a mutually rewarding relationship.

Periodic meetings between the airport concession manager and the concession operators to discuss performance and upcoming events that may affect concession operations, to pose and answer questions, and to address other topics of interest that arise are recommended. During periods when the concessionaire's business is getting established and during periods when major changes are occurring, more frequent meetings should take place. Topics for discussion at the individual meetings should be established by the airport concession manager in agenda format in advance and circulated to the concessionaire for review and comment prior to the meeting. The concession operator should have the opportunity to add relevant items and issues to the agenda.

In addition, joint meetings with tenant managers of concessions and other businesses at the airport should be held monthly. These meetings serve to get the word out quickly and efficiently to airport tenants on matters of importance, such as security rules, construction plans and updates, airline schedule changes, new gate assignments, and the like. In addition, monthly meetings offer a valuable forum for sharing matters of interest for all attendees. However, if an issue specific to a particular concessionaire arises, it is best to discuss the issue in an individual meeting rather than in a group setting.



Another valuable meeting is the semi-annual or annual performance review wherein financial results and sales and revenue forecasts for given time periods are presented, and the concessionaire is given an opportunity to present ideas, suggest operational changes, and discuss areas of concern. These meetings may be attended by the airport's senior management, especially in the case of larger concession agreements such as Prime Concessionaires, Third-Party Developers, and Leasing Managers.



Other methods of communication that may be used by the airport operator may include tenant directives, tenant advisories, written correspondence, email, telephone calls, and emergency meetings. Concession managers must make decisions on the best method of communication,



taking into account the nature of the topic and its time sensitivity. In any case, all matters communicated to concessionaires and their reactions and responses should be clearly documented.

All of the airport concession managers in our survey who perceived themselves to be effective in managing and improving the performance of their concession programs believed that regular communications with concession tenants was a key contributor to their effectiveness. Monthly or bimonthly meetings with tenants were cited as a particularly effective forum for communicating information and discussing issues and concerns.

Compliance with contractual terms and conditions, the reasonableness of contractual interpretations, the willingness to discuss and consider each other's needs and positions, and fairness and flexibility in problem solving are some of the key elements in building and maintaining successful relationships. While the nature of the job of managing airport concessions can sometimes be adversarial, trust and cooperation can be developed by listening to concession tenants' concerns and being advocates when they need assistance in resolving operational and other issues. Good tenant/management relationships are key to the success of the concession program.

### 13.6 Marketing the Concession Program

Marketing may be the responsibility of the concessions manager, the concessionaire(s), or both. Consultation with concessionaires can ensure broader cooperation on marketing efforts and contribute to making good marketing decisions. Common marketing methods include brochures, concession directory boards, radio and television advertisements, web-based advertisements, special events, banners, dioramas, menu boards, signs, sidewalk sales, promotional give-aways, and mass mailings.

Figure 13-2 shows an example of a concession brochure created for Hartsfield-Jackson Atlanta International Airport. The brochure presents an overview of the concessions by major category

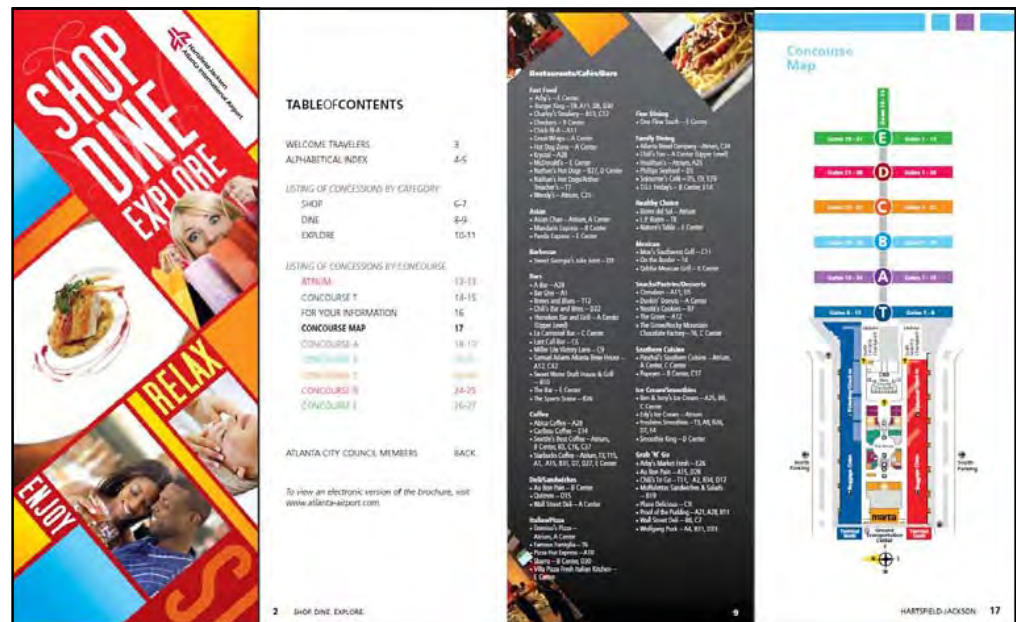

Figure 13-2. Example of a concession brochure (Hartsfield-Jackson Atlanta International Airport).

The screenshot displays the website for Dallas/Fort Worth International Airport (DFW). At the top, the DFW logo and name are visible, along with navigation links for 'DFW Home', 'Mobile Site', and 'Contact Us'. A search bar is located below the header. The main navigation bar includes 'FLIGHT INFORMATION', 'AIRPORT GUIDE', 'SHOP, EAT & SERVICES', 'TRAVEL PLANNER', and 'BUSINESS OPPORTUNITIES'. The 'Shop, Eat & Services' section is active, showing a list of restaurants under the 'American' category. The listed restaurants include Bannigan's (D11), Champps Grill & Bar (D24), Cool River Cafe (D25), Fuddrucker's Hamburgers (Marche) (D18), and Reata Grill (D33 Upper Level). Each listing features a small image and a brief description. To the right, there are promotional banners for 'TripCase Value Offers' and 'Connect on Skylink'. At the bottom right, there is a 'Shop, Eat & Services' filter section with dropdown menus for 'Select All Terminals' and 'Select All Types'.

**Figure 13-3. Example of concession information on an airport website (Dallas/Fort Worth International Airport).**

and presents location maps by concourse showing the concession locations. The brochure is available for viewing on the airport website and can be viewed by persons online while in the airport or can be downloaded as a portable document file (.pdf).

Airport websites serve a similar function, and can inform passengers of the available food, retail offerings, and services at an airport. Figure 13-3 shows an example of the concessions listing on the Dallas/Fort Worth International Airport website.

Many large airports outside the United States offer online catalogues and the ability to order goods in advance. This opportunity provides outbound passenger with a means to minimize time spent picking up merchandise at multiple locations at the airport. It is particularly effective for bulk purchase of items such as cigarettes and alcohol, where the customer's preference is established.

### 13.6.1 Branding the Concession Program

Raising awareness of and the reputation of the airport concession program should be long-term goals. One approach to raising the profile of the concession program is to brand the program, which can strengthen its identity with customers and help raise overall sales. The Port of Portland brands the landside concession area at Portland International Airport as the "Oregon Market." The developer of the concession programs uses its "AIRMALL" brand at Baltimore/Washington International Thurgood Marshall, Boston Logan International, Cleveland Hopkins International, and Pittsburgh International Airports.

The branding of retail programs at major airports outside the United States is common. At Amsterdam Airport Schiphol, a world leader in airport concessions, a distinctive yellow shopping bag is used for all purchases at its concessions. The bag features the airport's See/Buy/Fly



**Figure 13-4.** Example of a distinctive shopping bag advertising the concession program (Amsterdam Airport Schiphol).

logo, and is widely recognized by international travelers around the world (see Figure 13-4). At Incheon International Airport, the retail program is branded as Airstar and its duty free shops as Airstar Avenue. The operator of Hong Kong International Airport promotes its Skymart. Branding the shops indicates to passengers that the shopping at the airport is special and a cut above the usual shopping experience at airports.

### 13.6.2 Marketing Funds



At many large and medium hub airports, the terms included in concession agreements may require concessionaires to pay into a marketing fund, which is used to market the airport's concession program. Moneys in the marketing fund are used for promotions; advertising; collateral materials; and quality control programs, including passenger surveys and secret shopper programs. The fees paid into the marketing fund by each concessionaire typically range from 0.25% to 0.50% of sales. These fees are collected with rents as a separate item and are typically maintained in a fund whereby unused moneys at the end of each year are rolled over to the following year. Concession managers should keep strict records of how and when the moneys are used, and periodic accountings should be provided to the concessionaires of such uses and remaining fund balances.

Establishing a marketing fund often affects the airport operator's budgetary procedures. For example, in their bond enabling legislation, many airport operators have pledged that all operating revenues will be deposited in a fund to cover operating and maintenance expenses, debt service, and other required deposits. Therefore, the amount in the marketing fund may technically need to be reauthorized in the following year's operating budget.

### 13.7 Organizing the Concession Staff

The number of concession management staff may vary from as few as two individuals with responsibilities in addition to their responsibilities for the concession program at small hub airports to numerous individuals that deal only with concessions, but in separate units with different

functional responsibilities. It is the job of the concessions department leader to determine the optimum organizational structure and assignment of available staff.

Separation of duties by functional responsibility should be considered in those cases where the number of concession staff allows for specialization. When organized around functional areas of responsibility, a concession management department would include organizational units under the concession manager, as follows:



- **Contract development unit.** Prepares solicitations and concession agreements, negotiates contract document terms and conditions, prepares board agenda items, and may negotiate and prepare concession agreement amendments. Concession staff in this unit should have strong writing skills, pay attention to detail, have the ability to understand and develop legally accurate contract provisions, have negotiation skills, and have the ability to clearly and accurately prepare and present information for consideration by senior management and policy makers.
- **Contract monitoring unit.** Responsible for overall management and enforcement of concession agreement terms and conditions. The staff in this unit are in frequent contact with the concessionaires' local representatives, and should have strong personal interaction skills. Staff should have the ability to read and understand the terms and conditions of concession agreements and the ability to recommend enforcement actions when needed. The individuals in this unit function as day-to-day contacts for the concessionaires and should be prepared to advocate for the concessionaires as the need arises.
- **Contract administration unit.** Responsible for recordkeeping and ensuring that documentation required by the concession agreement (e.g., insurance certificates, surety bonds, and operating permits) are in place. This unit typically has responsibility for maintaining the lease management database and for file management. Staff members in this unit should have strong administrative skills.

### 13.7.1 Reporting Relationships of Concession Managers

According to the survey conducted for this research project, the individual with primary full-time responsibility for the concession program at large hub airports is most likely to report to the airport operator's commercial director or an overall deputy director (67%). The next most likely reporting relationship at large hub airports is to the finance director or chief financial officer (CFO) (17%).

At medium hub airports, the reporting relationship is equally likely to be to the airport operator's commercial director or deputy director (33% each). At small hub airports, which have smaller organizations, more than half of concession managers report directly to the airport director, chief executive officer (CEO), or chief operating officer (COO) (55%). The next most likely reporting relationship is to the finance director or CFO (45%). Figure 13-5 summarizes the reporting relationships identified by respondents to the survey.

## 13.8 Performance Monitoring

Successful performance monitoring requires well-trained, experienced staff with a good understanding of the concession agreements and time allocated to monitoring duties. Although on-the-job training is typical, consideration should be given to developing a training program that can be used for those new to the airport operator's contract monitoring unit and as a periodic refresher for other staff.

In cases where more than one staff member is assigned to concession monitoring duties, the person in charge should develop a contract monitoring assignment list with a primary and



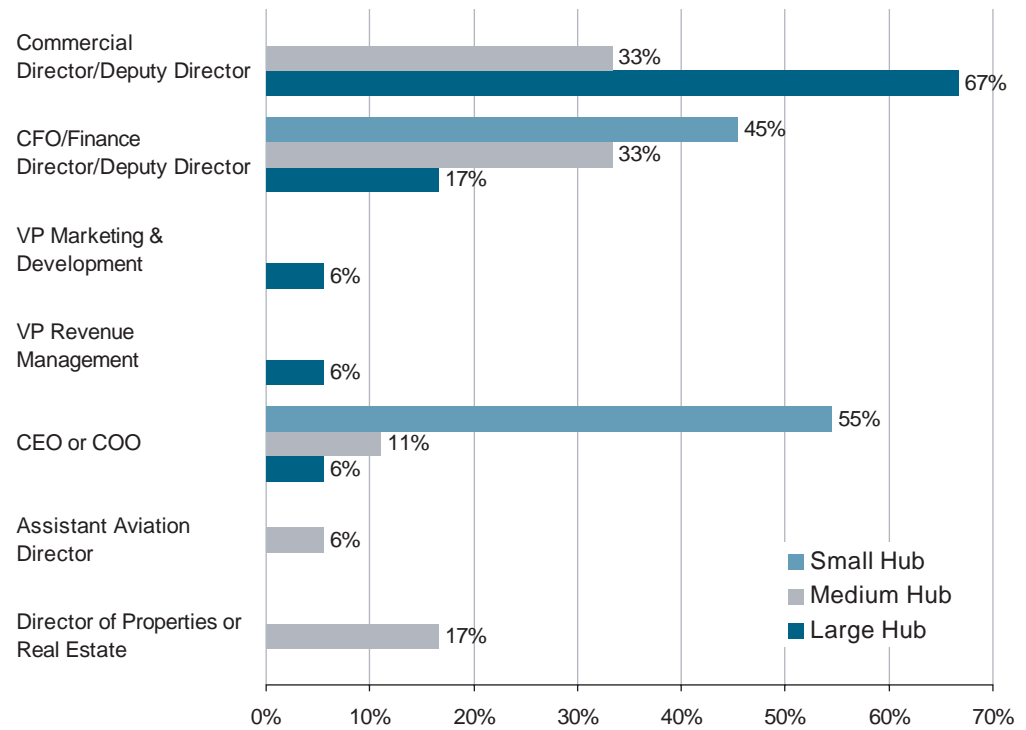

**Figure 13-5. Reporting relationship of person with primary responsibility for the airport concession program.**

backup staff member listed for each concessionaire. Periodic rotation of staff assignments may be used as an effective cross-training tool.

At a minimum, the concession manager's duties include the following:

- Understanding the underlying terms and conditions of the concession agreements to be monitored
- Assessing risk to determine where monitoring time is best spent
- Developing and documenting a monitoring plan
- Interacting regularly with concessionaire managers
- Developing an understanding of each category of concession operation
- Conducting compliance reviews
- Providing constructive feedback to concessionaire management, as needed
- Responding to concessionaire questions and requests and advising concessionaires of upcoming events that may affect their business
- Acting as an advocate for the concessionaire when needed
- Following up on customer complaints
- Reviewing and evaluating concessionaire performance
- Briefing senior management on concessionaire activities
- Taking corrective action to address noncompliance when necessary

Quality control practices (discussed in Chapter 3) are an important part of concession performance monitoring. In monitoring concession agreements, mystery shoppers, customer comment cards, passenger intercept surveys, focus groups, performance metrics, and discussions with counterparts at peer airports are often used, as well as field visits to similar types of businesses at other locations to compare operations. Figure 13-6 shows the frequency of use of major quality control practices by hub size.



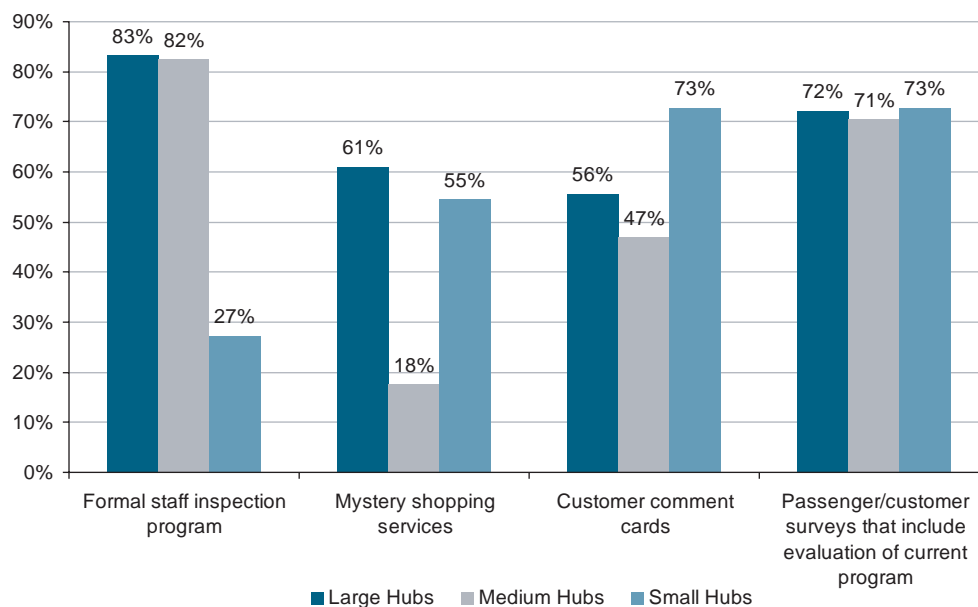

**Figure 13-6. Quality control practices and frequency of use in managing the concession program.**

An overview of tools for measuring customer satisfaction, including sales monitoring, passenger surveys, comment cards, mystery shoppers, and focus groups is provided in Chapter 3. In addition to these quality control tools, survey participants cited other quality control practices, as listed below:

- Customer complaint hotline (email and telephone)
- Customer service awards for concession employees
- Food health and safety program
- Informal staff inspections
- Monthly terminal walk-throughs
- Periodic customer intercept surveys
- Regular monitoring for street price and hours of operation compliance
- Website comments

### 13.8.1 Physical Inspections

As part of concession performance oversight, “walk-around management” is an effective performance-monitoring tool. Walk-around management may be an informal activity on an unscheduled (and frequent) basis in which the concessions are visited as a customer or as an observer to see how well the concessions appear to be operating, or walk-around management may involve more formal inspection visits.

Thorough inspections of facilities should be conducted periodically by the concession manager accompanied by the concessionaire manager, who can explain operations, answer questions, and provide access to all operational areas. These formal inspections may be prearranged, or they may occur with little or no advance notice so that the concessionaire does not have time to get prepared and the concession manager can see the operation “as is.”

Inspection checklists should be developed in advance and filled out during the physical inspections. Results should be reviewed with concessionaire management. The checklist should answer the following questions:

- Is the concession clean?
- Are prices prominently displayed for each item?



- Are approved prices being charged?
- Are product display areas well stocked?
- Are any food or beverage products on the menu unavailable?
- Is the product presentation consistent with the concessionaire's normal standards?
- Is the concessionaire selling food products beyond their expiration dates?
- Is there any counter clutter?
- Is the concessionaire complying with signage policies?
- Are an adequate number of cashiers available?
- Are concessionaire staff members complying with dress codes?
- Is loud or inappropriate music being played?
- Does the concessionaire's staff appear to be providing good customer service?
- Does everything appear to be in working order?



Concession facilities should be visited at opening and closing times on a regular basis to determine whether concessionaires are complying with approved hours of operation. This visit may be by the concession manager or by others, as arranged by the concession manager (e.g., mystery shoppers). Opening and closing times are established based primarily on outbound flight schedules to provide good customer service for departing passengers. Opening times are important from both a revenue and customer service standpoint. For example, it is important that morning coffee and breakfast items are available and that newsstands are open and stocked with newspapers and other periodicals in time for the early morning departure peak, which, at many airports, is the busiest time of the day. Likewise, it is important to maintain service standards until approved closing times. Closing activities should not be visible to patrons during operating hours. The concession manager should coordinate with the concessionaire to discuss and determine the policy regarding whether full menus will be available until the approved closing time or whether a more limited menu can be offered as closing time approaches.

### 13.8.2 Enforcement Actions



One of the most difficult concession management responsibilities is determining how and when to implement enforcement actions against a concessionaire who is not complying with the terms and conditions of the concession agreement. The ultimate enforcement of termination is rarely sought, especially for relatively minor, but continuing infractions. Even in the case of more egregious violations (e.g., late payments of rent, expired surety bonds, failure to complete construction on schedule), the time and expense of terminating a concession agreement makes such actions prohibitively time consuming, expensive, and impractical. If termination is sought, the airport operator may lose revenue resulting from store closures while replacement concessionaires are sought. In reality, public airport operators are subject to a high level of scrutiny and judicial skepticism when seeking to terminate the contract of a concessionaire.



For these practical reasons, airport operators often include fines, sanctions, or liquidated damages (penalty clauses) in concession agreements as a disincentive to committing the violations noted above. These penalty clauses provide for escalation of the amounts to be paid to the airport operator for recurrence of the same violation, and do not preclude other rights and remedies addressed in the concession agreement, such as a declaration of default. Violations subject to penalty clauses may include, for example:

- Failure to operate during established business hours
- Failure to submit reports on time
- Failure to comply with the approved pricing policy
- Noncompliance with the airport operator's trash disposal and recycling program
- Maintenance and cleanliness deficiencies
- Failure to comply with record retention requirements
- A variety of other performance failures, which are often tailored to deficiencies experienced at individual airports

Progressive actions are typically taken to address concession agreement compliance deficiencies. These actions should be listed in the concession agreement or included in airport policy documents. Great care should be taken in determining and documenting the progressive actions to be taken to ensure that the ability to address more egregious deficiencies is not unduly limited and that harsh action is not mandated for minor infractions. The nature of the violation, the date by which the violation must be corrected, and the enforcement action to be taken should all be provided to the concessionaire in writing. Consistency in application is also necessary to avoid claims of favoritism or unjust treatment of one concessionaire or tenant versus another. A sample series of progressive actions that may be taken to enforce performance standards is shown below:



- **First Notice**—concessionaire receives notice of a violation.
- **Imposition of Penalty**—an amount of money is assessed against the concessionaire because of a violation. The penalty may be imposed for the first violation or may only apply if the violation continues beyond a stated grace period or recurs. The amount of the penalty may escalate for subsequent similar violations or failure to cure within a stated grace period.
- **Declaration of Default**—for certain violations (e.g., lapse of insurance coverage), default may be declared immediately. For less serious violations, notices should be given, or, possibly, penalties may be imposed first.
- **Notice of Termination for Default**—failure to cure a default within a certain stated period results in a notice of termination. Airport policy and/or the concession agreement will dictate whether the concessionaire is to be given additional time to correct the default and avoid termination.

Another sample set of steps in progressive enforcement of concession agreements is the following:

- Identify the potential violation.
- Read and review pertinent provision(s) of the concession agreement.
- Confirm your understanding of the concession agreement provisions with the author of the document and/or legal counsel.
- Notify the concession manager to correct the violation (may be verbal or written depending upon the nature [seriousness] of the violation and whether it is an initial incident) and a time period for correction.
- Impose any fines or penalties in accordance with the concession agreement.
- Document the notification and any imposition of fines or penalties in writing.
- Follow up to determine whether corrections have been made within the cure period.
- If the violation continues, fines or penalties may be imposed again, as provided for in the concession agreement. Depending on the seriousness and frequency of the violation, the concession contractor may also be placed in default at this time (it is a judgment call on when to take this course of action) by written notice to the party identified in the Notices section of the concession agreement. A cure period should be stated in the default letter.
- Follow up to determine if corrections have been made within the cure period.
- If the violation still continues, send a termination letter to the concession contractor, in accordance with the Termination section and the Notices section of the concession agreement.

Before taking enforcement actions against tenants, concession managers should ensure that the violation is documented by internal or external sources. Internal sources may prepare written documents, such as inspection reports, notes from visits to concession facilities, or memoranda to file or letters to the concessionaire identifying the violation. External sources, which are often considered more credible if the concessionaire challenges the action, may prepare written documents, such as mystery shopper reports, customer complaints, and third-party inspection



reports (e.g., health department, alcoholic beverage commission, and fire department). This type of documentation can also be of great value to airport management as it decides whether or not to extend the term of a concession agreement, award a new concession agreement to an incumbent, or provide a reference for a concessionaire.

Airport concession managers should be empowered to make First Notice and Imposition of Penalty progressive enforcement determination decisions and should have quick access to legal counsel and airport policy-makers, if assistance in making such decisions is needed. Great care should be taken to avoid implementing enforcement actions prematurely or incorrectly, as this can create embarrassment and make future enforcement actions more difficult. Potential default and termination actions should always be reviewed and approved by legal counsel and upper management before the concessionaire is notified.

Finally, even small fines can have a desired effect, particularly if notice is given to both the local concessionaire manager and the concession operator's corporate representative. Any fine that has a negative effect on the concessionaire's net income will be noticed and should result in attention to fixing the problem.

### 13.8.3 Dealing with Underperforming Tenants

Annual sales expectations should be established for each concessionaire based on pro forma sales estimates, sales at other locations, and the concession location. Underperforming tenants create one of the most difficult challenges for airport concession managers. In addition to poor revenue performance, the concessionaires may have substantial time remaining in their terms and may ask for rent relief or some other form of assistance to compensate for financial losses. Underperforming tenants may even take action against the airport operator, claiming that their losses resulted from actions of the airport operator, whether justified or not.

There is a cause-and-effect relationship between failure to meet sales targets and operational problems. The concessionaire may attempt to cut expenses to compensate for low sales, which may reduce sales even further, thus creating a downward spiral.



It is incumbent upon the airport concession manager to recognize concessionaire shortcomings and to try to work with underperforming tenants to improve their situation. Some strategies the concession manager may implement to this end are as follows:

- Holding regular and frequent meetings and discussions with local concessionaire management to identify the causes of underperformance and potential solutions.
- Bringing in outside expertise (e.g., a retail consultant) to identify ways that the underperforming tenant may be able to improve its results.
- Communicating directly with corporate management and asking that their attention be focused on solving the problems at hand.
- Requesting or requiring replacement of local concessionaire management.
- Reviewing policies and procedures and the operating requirements placed on the concessionaire to determine whether any reasonable changes can be made to assist the underperforming tenant without compromising customer service. These changes could include, for example, adjustment of required hours of operation or price changes.
- Reconcepting of the unit.
- Negotiating a buyout.

If such attempts are not successful, contract termination discussions may proceed or, subject to the terms and conditions of the concession agreement, termination for default may occur. Senior management should be included in the decision-making process before any termination actions are taken.

### 13.9 Reconcepting Existing Units

When concession units are underperforming, reconcepting by the incumbent concessionaire may be a viable strategy. Before any decision on a request to reconcept a unit is made, the airport concession manager should determine the following:

- Will a buyout be required and, if so, how much will it cost?
- What is the sales and revenue improvement that can reasonably be expected from the reconcepted unit?
- How long will the store be closed before the reconcepted store opens?
- Is there an opportunity to install a temporary replacement concept during store closure to minimize revenue loss?
- Is there sufficient length in the term of the concession agreement to cover the costs of reconcepting?
- Will the new concept overlap with nearby concepts?
- Does the new concept fit well with the overall concession plan?
- Is the concept the problem, or is the concessionaire the problem?
- Why might the new concept fare better than the previous concept?
- How do we develop a successful opening strategy for the replacement concept?

A documented business plan should be submitted by the concessionaire, along with pro forma sales and expense estimates for the remaining term of the concession agreement before any approval to reconcept is granted. If operational problems appear to have been a cause of underperformance, the concessionaire should be prepared to explain what operational improvements it plans to make.

If the reconcepting request is based on an extension of the term of the concession agreement, considerable care should be taken in evaluating the request. Term extensions are extremely valuable. Granting a term extension precludes the ability of the airport operator to use the space as it sees fit once the current agreement has expired. Airport staff should also consider if a term extension is rewarding poor performance and if it would be considered a precedent that other concessionaires will seek. If underperforming concessionaires are granted term extensions, why not grant concessionaires that perform term extensions as well? For these reasons, a reconcepting request predicated on a term extension should be considered carefully and only after careful and documented business analysis. The approval should take into account the effect of the decision on other tenants and on the concession program overall, but most of all, it should be based on a clear benefit to the airport enterprise.



### 13.10 Transition Planning

As contract expiration dates near, the airport concession manager should anticipate and plan for a smooth transition to the succeeding concessionaire. A sample agreement closeout checklist is the following:

- Upon closure:
  - All inventory and personal property must be removed.
  - Space must be left in broom clean condition.
  - All employee badges must be returned.
  - All employee parking permits must be returned.
  - Concession name must be removed from all signs, directories and publications.
  - Space must be inspected and any items needing repair must be documented in list form.
- Within a stipulated time period after closure:
  - Repairs must be completed.

- All final reports as required by the concession agreement must be filed.
- All final payments as required by the concession agreement must be paid whereupon performance/payment guarantees (e.g., bonds, letters of credit) may be cancelled.
- Any buyout of improvements owed to the concessionaire must be paid.
- Performance bonds/letters of credit may be cancelled.

Concession managers should work in concert with the existing and succeeding concessionaire(s) to the extent possible to plan the concession turnover. Cooperation on the part of the exiting concessionaire has been the norm at airports overall, as most concessionaires are concerned with their reputations and may have an interest in returning at a later date. Additionally, the airport community is small and word travels quickly; it would not be in the concessionaire's best interests to earn a reputation as an uncooperative exiting tenant when it will be competing for spaces at other airports. Fortunately, cooperation between the incoming and outgoing concessionaire is based on an expectation of reciprocity, as the roles will likely be reversed some day.

In some cases, there may be value in continuing an incumbent concessionaire through a sub-contract arrangement while the new concessionaire designs and constructs improvements. This approach can help maintain service to passengers and provide income to the airport enterprise during the transition period.

For an outgoing concessionaire, its management, and employees, the incentive to perform at the highest level may decline as the end of the concession agreement term nears. Although most concessionaires will use their best efforts to continue business as usual, there is the potential for employee turnover or indifference resulting from uncertainties regarding continued employment. At one large hub airport transitioning from a Prime Concessionaire to a Third-Party Developer agreement, service deteriorated as outgoing local managers failed to maintain adequate control over their business, and employee morale plummeted. The airport operator had to accelerate the transition to maintain reasonable levels of service and avoid public criticism. Performance monitoring and enforcement activities should be increased during the waning months of a concession agreement to ensure that proper customer service is maintained and to identify problems before they become more serious.



To address concession employee job uncertainty, some airport operators insert a “first consideration in hiring” clause in the succeeding concession agreement, whereby existing employees are provided some degree of assurance that the contract turnover will not result in job loss. Possible policy options range from mandatory hiring of existing employees for a minimum probationary period to less stringent actions, such as job fairs and arranging interviews for existing employees. With some planning by the airport operator, employee transition concerns can be minimized. In most cases, the incoming concessionaire will want to draw upon employees who already understand the airport operating environment, have passed security background checks, and are willing to make the commute to work at the airport.



Establishing a clear transition plan with the incoming and outgoing concessionaires will minimize problems for all concerned. A transition checklist, including concession agreement close-out actions (as shown above), should be developed by concessions management approximately 6 months prior to initiating the new concession agreement to ensure that the transition proceeds smoothly and customer service disruptions are minimized.

### **13.11 Airports with Well-Managed Concession Programs**

There is considerable value in networking with peers regarding airport concession programs to determine what has and has not worked well. Fortunately, airport operators tend to be coop-



erative and participate in industry associations and conferences to share information and network with peers.

Concession managers and their staffs can particularly benefit by visiting with their counterparts at airports with concession programs that have a reputation within the industry for being well managed. Consultants and concessionaires that were surveyed for this research project cited the airports listed below as having particularly well-managed concession programs (Canadian airports listed at U.S. hub size equivalent):

- Large Hubs
  - Dallas/Fort Worth International Airport
  - Las Vegas McCarran International Airport
  - Los Angeles International Airport
  - Minneapolis-St. Paul International Airport
  - Phoenix Sky Harbor International Airport
  - Salt Lake City International Airport
  - San Francisco International Airport
  - Tampa International Airport
  - Toronto Pearson International Airport
  - Vancouver International Airport
- Medium Hubs
  - Austin Bergstrom International Airport
  - Calgary International Airport
  - John F. Kennedy International Airport–JetBlue Terminal
  - Montreal Trudeau International Airport
  - Nashville International Airport
  - Ottawa International Airport
- Small Hub
  - Norfolk International Airport



## CHAPTER 14

# Case Studies

This chapter presents case studies of concession programs at selected domestic and international airports. The airports presented are as follows:

- Dallas/Fort Worth International Airport
- San Francisco International Airport
- Tulsa International Airport
- Portland International Airport
- Amsterdam Schiphol International Airport
- Seoul Incheon International Airport
- Copenhagen Airport

Each airport case study presents an overview of the airport, organized as follows:

- Ownership/Governance
- Traffic Overview
- Passenger and Market Characteristics
- Estimated Sales and Revenue
- Sales per Enplaned Passenger
- Concessions
- Terminal Configuration
- Commercial Strategy
- Unique Concessions and Innovations

### **14.1 Dallas/Fort Worth International Airport**

#### **14.1.1 Ownership/Governance**

Dallas/Fort Worth International Airport (DFW) is governed by a 12-member Airport Board of Directors (Board). Seven members of the Board are appointed by the Dallas City Council, and four are appointed by the Fort Worth City Council in accordance with each City's ownership interest in the airport. One nonvoting member rotates on an annual basis among the cities of Coppell, Euless, Grapevine, and Irving.

The Board is a semi-autonomous body charged with governing the airport and may enter into contracts without approval of the City Councils. The Board appoints the Chief Executive Officer, who is charged with the day-to-day operations of the Airport. The Chief Executive Officer, in turn, hires a professional management team to assist him in that responsibility.

### 14.1.2 Traffic Overview

In 2009, DFW ranked fourth in the United States and seventh in the world in terms of total passengers with 26.7 million annual enplaned passengers. DFW is served by 18 airlines, including 11 domestic passenger airlines and 7 foreign flag carriers. The airport is the largest hub and headquarters for American Airlines and American Eagle.

### 14.1.3 Passenger and Market Characteristics

O&D passengers account for 43% of total passenger traffic, and connecting passengers account for 57%. DFW passenger demographics vary somewhat by terminal. For example, in Terminal A, connecting traffic makes up more than half of all enplaning passengers (62%), who are largely business passengers (63%) and mostly male (64%). Sixty-eight percent of the passengers are between 25 and 54 years old. Of this group, 50% had household incomes above \$75,000 and 30% had household incomes over \$100,000. Terminal E is at the other end of the market spectrum and has 86% O&D traffic with 55% leisure passengers and 54% males. Sixty-four percent of the passengers are between the ages of 25 to 54. Household incomes were higher for customers in Terminal E; sixty percent had incomes over \$75,000 and 38% had household incomes of \$100,000 or more.

### 14.1.4 Estimated Sales and Revenue

DFW had total concession sales of \$264 million in 2008, as shown in Table 14-1.

The difference in passenger demographics is partly reflected in the spend rates in the terminals. Other factors, including size and location of concession space, passenger volumes, and the range of concessions offered, also affect spend rates. Table 14-2 shows the variation in food and beverage and retail spend rates by terminal. Terminal D functions as a domestic terminal for American Airlines and as the major international terminal for the entire airport and handled 2.6 million enplaning international passengers in 2008, more than 95% of total international enplaned passengers. The international passengers drive higher retail spend rates. Terminal D produced sales per enplaned passenger that averaged 145% of the airport average. Duty free sales in Terminal D were \$4.17 per international enplaned passenger in 2008.

Sales per enplaned passenger by category are shown in Tables 14-2 and 14-3. DFW achieved sales per enplaned passenger of \$8.39 on the core concessions of food and beverage and retail, as shown in Table 14-3.

**Table 14-1. Annual concession sales by category (Dallas/Fort Worth International Airport)—2008.**

	Concession sales (millions)	Net revenue to DFW (millions)
Food and beverage	\$ 145.0	—
Specialty retail	66.9	—
Convenience retail	31.5	—
Duty free	11.0	—
Advertising	10.2	—
Telephone, Wi-Fi	n.a.	—
Other concessions	n.a.	—
	<b>\$ 264.6</b>	<b>n.a.</b>

Source: LeighFisher. Data from *Airport Revenue News Fact Book 2009* (Airport Revenue News 2009).

**Table 14-2. Enplaned passengers, sales, and sales per enplanement by terminal (Dallas/Fort Worth International Airport)—2008.**

Terminal	Enplaned passengers (millions)		Concession sales (millions)		Sales per enplaned passenger	Percent of airport average
	Share	Share	Share	Share		
A	7.146	25%	\$ 53.5	22%	\$ 7.49	89%
B	3.777	13%	28.6	12%	\$ 7.57	90%
C	8.193	28%	56.1	23%	\$ 6.85	82%
D	6.731	23%	81.8	34%	\$ 12.15	145%
E	3.134	11%	23.1	9%	\$ 7.37	88%
	<u>28.981</u>	<u>100%</u>	<u>243.1</u>	<u>100%</u>	<u>\$ 8.39</u>	<u>100%</u>

Source: LeighFisher. Data from *Airport Revenue News Fact Book 2009* (Airport Revenue News 2009).

**Table 14-3. Annual sales per enplanement (Dallas/Fort Worth International Airport)—2008.**

Category	Sales per enplaned passenger
Food and beverage	\$ 4.99
Specialty retail	2.31
Convenience retail	1.09
	<u>\$ 8.39</u>
Duty free <sup>(1)</sup>	\$ 4.02

<sup>(1)</sup> Per international enplaned passenger.  
Source: LeighFisher. Data from *Airport Revenue News Fact Book 2009* (Airport Revenue News 2009).

### 14.1.5 Concessions

DFW has the largest direct leasing concession program of any U.S. airport. The airport has more than 120 food and beverage locations and more than 100 retail shops.

In each food category in food and beverage, there is a range of choices for travelers including familiar national brands and offerings from regional and local operators:

- American (9 concepts, 15 locations)
- Asian (2 concepts, 4 locations)
- BBQ (3 concepts, 6 locations)
- Cocktail Lounges (4 concepts, 7 locations)
- Coffee (2 concepts, 18 locations)
- Delis and Bakeries (6 concepts, 12 locations)
- Desserts and Snacks (7 concepts, 22 locations)
- Fast Foods (8 concepts, 21 locations)
- Grand Hyatt Dining (3 concepts, 3 locations)
- Italian (3 concepts, 4 locations)
- Mexican (6 concepts, 7 locations)

The airport classifies its retail locations into the following:

- Accessories and Gifts
- Apparel
- Books and News
- Children's
- Convenience Stores
- Duty Free
- Education/Language
- Home and Electronics
- Sports
- Tax Free and Texas Gifts

Services offered at DFW include the following:

- ATMs
- FAX
- Western Union
- FedEx and U.S. Postal Service
- The Neat Company (scanners)

- free sponsored power outlets for portable devices
- Wi-Fi
- Samsung mobile travel lounge.

Samsung also sponsors televisions located in holdrooms around the airport as part of a sponsorship arrangement involving cash payments and equipment. Travel services include travel insurance and foreign currency exchange. Personal services concessions include barbershops, a salon, manicures and pedicures, massage chairs, massage therapists, and luggage carts.

### 14.1.6 Terminal Configuration

DFW has five terminals, four of which are curvilinear (Terminals, A, B, C and E). All terminals are connected by the Skylink elevated train, which allows connecting passengers to transfer on the airside without having to exit the secure area. The curvilinear terminals present challenges for concessions, as the gates are single-loaded (gates on one side of the passenger concourse), resulting in longer distances between concessions. Terminal D has a unique configuration combining a curvilinear curbside and a rectangular terminal building with two shopping streets located immediately beyond the two main security checkpoints. Terminal D also serves as the international terminal, with about 40% of its 6.7 million passengers departing on international flights. As a result, Terminal D is able to offer a larger concession program with extensive specialty retail space and achieves an average spend rate that is 145% of the overall airport average. The configuration of each terminal is shown in Figure 14-1.

DFW has more than 223,000 square feet of concession space, as shown in Table 14-4. The airport is implementing a terminal redevelopment plan that will improve the existing terminals and add concession space in accordance with its adopted planning standard of maintaining 8 to 10 square feet of concession space for every 1,000 enplaned passengers. When completed, the average space per 1,000 enplaned passengers will be near the total airport average, but space will be added to constrained Terminals A and C while space will be reduced in Terminal E, which has a surplus of supportable concession space relative to passenger traffic.

### 14.1.7 Commercial Strategy

DFW serves an enormous market, but must also deal with some challenges. These challenges include a high percentage of connecting passengers, the size of the airport, and long distances between departure gates due to the curvilinear terminal.

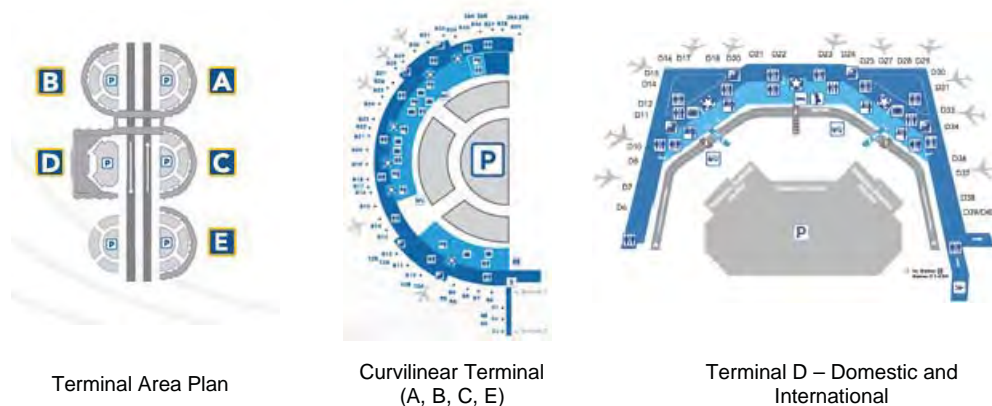

Source: DFWairport.com (As of October 12, 2010).

**Figure 14-1.** Dallas/Fort Worth International Airport terminal configuration.

**Table 14-4. Concession space by terminal (Dallas/Fort Worth International Airport)—2008.**

	Enplanements (millions)	Concession space (sq ft)	Space per 1,000 Enplanements
Terminal A	7.1	45,129	6.3
Terminal B	3.8	34,035	9.0
Terminal C	8.2	42,373	5.2
Terminal D	6.7	60,788	9.0
Terminal E	3.1	40,812	13.0
	29.0	223,137	7.7

Source: LeighFisher. Data from *Airport Revenue News Fact Book 2009* (Airport Revenue News 2009).

Connecting passengers make up more than half (57%) of enplaning passengers. Connecting passengers typically spend at a rate of about 60% of O&D passengers. In order to realize high average sales, it is important to provide concessions close to the departure gates to serve time-sensitive connecting passengers.

The size of the airport makes it challenging for some connecting passengers. For example, American Airlines passengers are spread over Terminals A, C, and D. The airport built its Skytrain system to make it easier and faster for passengers to connect between terminals. There are two Skytrain stations in each terminal. The Skytrain system allows for faster concessions and more time for use of concessions.

The curvilinear terminal has aircraft parked on only one side. Therefore, departure gates are distributed over a wider distance than conventional, double-loaded terminals with aircraft on both sides of a pier or finger. This makes for longer walking distances, and, as the terminal is curved, it is difficult to see concessions around the bend. The airport is adding concession space around the Skytrain stations, which are heavily traveled by connecting passengers and which are also located opposite the major security checkpoints. Thus, the areas around the Skytrain stations are exposed to large concentrations of both connecting and O&D passengers and are the most desirable area in which to cluster concessions.

The DFW Board has a policy of encouraging ACDBE participation, and the airport has one of the largest ACDBE programs in the nation. The direct leasing program provides numerous opportunities for small, local, independent businesses to compete for concession privileges. In addition, larger packages include ACDBE goals to encourage subleasing. Overall minority business goals, including ACDBE goals, are approximately 35% as a percentage of sales. This goal is regularly surpassed. DFW minority concession sales account for more than half of total concession sales.

The concession program is an important part of DFW's overall brand strategy.

### 14.1.8 Key Concessionaires

Food and beverage concepts include Au Bon Pain, Auntie Anne's, Ben & Jerry's, Bannigan's, Blue Mesa Café, Burger King, Camille's Sidewalk Café, Cantina Laredo, Champps, Chili's, Cool River, Cousin's Barbecue, Dickey's BBQ, Dunkin' Donuts, Freshen's Yogurt, Manchu Wok, McDonald's, Pizza Hut, Popeye's Chicken, Starbucks, Subway, Taco Bell, TGI Friday's, The Grove, Varsity Grill, and Wendy's, among others.

Retailers include Airport Wireless, Bijoux Terner, Border's Newsstand, Brighton, Brooks Brothers, Brookstone, Official Dallas Cowboys Pro Shop, DFW Travel Mart, Fossil, Hudson Booksellers, InMotion Pictures, Jethro Pugh Shops, Johnston & Murphy, La Bodega Winery, Landau, L'Occitane, Natalie's Candy, PGA Tour Shops, Simply Books, Starbucks, Rosetta Stone, Sue Venier, Techshowcase, and Z Market, among others.



High-end branded vending machines are operated by Zoom Systems and include Body Shop, Proactive Facial Care, Sephora, and Best Buy Express.

Duty free is operated by Buckaroo Duty Free.

### 14.1.9 Unique Concessions and Innovations

#### *Mobile Technology*

DFW has developed a mobile website ([www.dfwairport.com/mobile](http://www.dfwairport.com/mobile)) that offers travelers access to different tools, including an application that suggests concessions nearest to each gate. Working with Sabre, DFW has taken it a step further so the users of the TripCase app ([www.tripcase.com](http://www.tripcase.com)) can receive special promotions on their iPhone or Blackberry from the airport's concessionaires based on their terminal location.

#### *Market Research*

DFW is an innovator in the use of market segmentation. DFW has employed Buxton, a market research consultancy, to conduct demographic research using Nielsen's Claritas market demographic identification and segmentation system. By capturing the zip codes of its originating and connecting passengers, DFW is able to segment its passengers into 63 distinct lifestyle groups that identify shopping and media preferences as well as key demographic and socioeconomic characteristics. Lifestyle groups are also characterized by urban density into four groups—urban, suburban, town and rural, and second city—and further classified according to socioeconomic rank and "lifestage" group, based on the presence and age of children.

DFW has identified what are considered core passenger segments for local originating customers and core passenger segments for customers making a connection at the airport. This information is useful in determining buying preferences and behaviors like brand loyalty, quality merchandise, functionality, and mix of concepts. As an example, DFW was able to tell its food and beverage concessionaire which brands of beers were most popular with its key segments. The brands identified through the market segmentation analysis were considerably different from the brands currently on offer. DFW uses the market segmentation data in identifying trends, brand preferences, product preferences, and gaps in the current concession program.

Eight core passenger segments were identified and described for local originating customers, as shown in Figure 14-2. Other segments were identified but not selected for individual recognition.

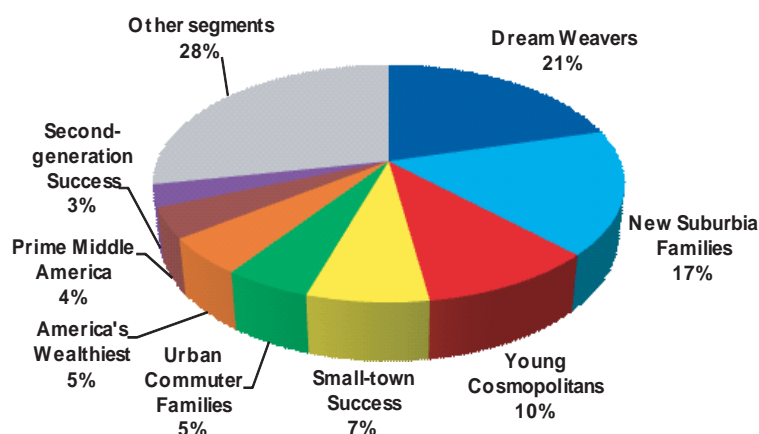

Source: Dallas/Fort Worth International Airport. Classifications based on Buxton Customer ID profiles, September 2009.

**Figure 14-2.** Dallas/Fort Worth International Airport core O&D passenger market segments.

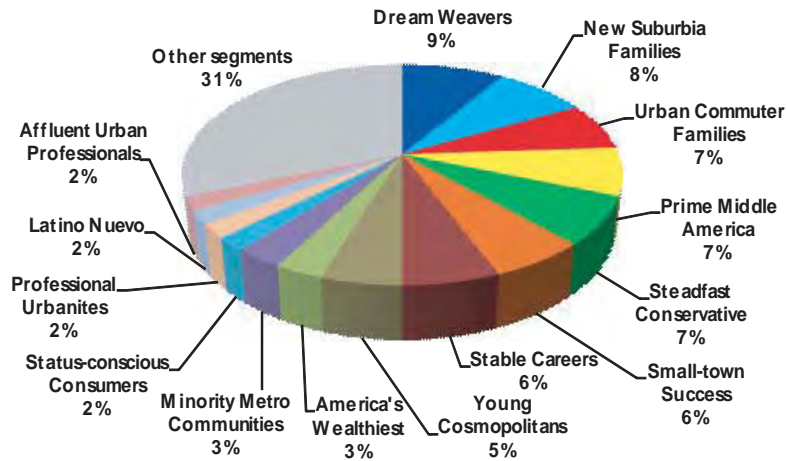

Source: Dallas/Fort Worth International Airport. Classifications based on Buxton Customer ID profiles, September 2009.

**Figure 14-3. Dallas/Fort Worth International Airport core connecting passenger market segments.**

The top three segments above make up 48% of the local originating passengers. Dream Weavers are characterized as affluent, living the suburban version of the American Dream. They are well-off families with school age children. New Suburbia Families are young with pre-school children. They are working couples and are concentrated in fast-growing metro-fringe communities. The third group, Young Cosmopolitans, consists of college educated, young singles earning upper-middle-class incomes as white-collar professionals, managers, and executives. These residents live in luxury apartments and condominiums in fast growing cities.

Fourteen core passenger segments were identified for customers making a connection at DFW, as shown in Figure 14-3. The fourteen include all the passenger segments listed above. Thirty-one percent of the customers represent “Other” segments not identified.

Along with the top three core passenger segments for originating passengers, the connecting audience has three additional top segments—Urban Commuter Families, Prime Middle America, and Steadfast Conservatives. Urban Commuter Families are college-educated Baby Boomers and couples living upscale lifestyles in city neighborhoods on the metropolitan fringe in comfortable, single, detached homes. Prime Middle America is a core passenger segment composed of a mix of young, upper-middle-class couples and families living in both small towns and mid-sized cities. Residents work in white-collar and blue-collar jobs that are well paying. The third ranking segment is the Steadfast Conservatives. These residents live in middle-class urban blue-collar neighborhoods and are mature singles and couples that are high school educated.

### *Sponsorships*

In addition to the arrangement with Samsung, DFW was the first airport to enter into an exclusive sponsorship arrangement for soft drinks with the local Pepsi bottler. Concessions at the airport sell Pepsi products exclusively. The airport receives sponsorship payments.

## **14.2 San Francisco International Airport**

### **14.2.1 Ownership/Governance**

San Francisco International Airport (SFO) is an enterprise fund department of the City and County of San Francisco. It is entirely self-sufficient. It is governed by a five-member Airport

Commission whose members are appointed for 4-year terms by the Mayor. In accordance with the City Charter, the Commission is primarily a policy-making body that establishes SFO's operating policies. Major contracts longer than 5 years or with revenue or expenses above a certain limit are subject to approval by the City's Board of Supervisors. The day-to-day responsibility for operation of the Airport is vested in the Airport Director, who is appointed by the Mayor.

### 14.2.2 Traffic Overview

SFO handled 18.5 million enplaned passengers in 2009 and ranked tenth in the United States and twentieth in the world. It is the second-largest commercial service airport in California after Los Angeles International, handling 18% of the state's domestic passengers and 32% of its international passengers.

SFO is served by 51 scheduled airlines and in 2009 handled 363,034 scheduled passenger airline operations. The airlines serve 73 non-stop domestic destinations, with 34 additional one-stop destinations. United Airlines (including SkyWest Airlines and United Express) handles the largest share of traffic (41%), followed by American Airlines (including American Eagle) (9.2%), and Delta Air Lines (including SkyWest Airlines, Express Jet Airlines and Mesaba Airlines) (4.9%). Twenty-eight international passenger airlines provide nonstop scheduled service to over 30 international destinations, with one-stop service to an additional 22 destinations.

In recent years, the Airport Commission has made a concerted effort to attract additional low-cost airlines service. Today, 22% of domestic enplaned passengers are carried on low-cost carriers including AirTran, Southwest, and Virgin America, which has its operations base near the airport. SFO is the dominant airport in the San Francisco Bay Area, handling a 66% share of total passenger traffic. The other one-third is handled by San Jose and Oakland airports.

### 14.2.3 Passenger and Market Characteristics

SFO is predominately an O&D airport, with 77% of its passengers beginning or ending their trip at SFO. Approximately 78% of passengers are domestic. The destination of passengers by world region is shown in Figure 14-4. SFO passengers are predominately leisure and business travelers, as shown in Figure 14-5.

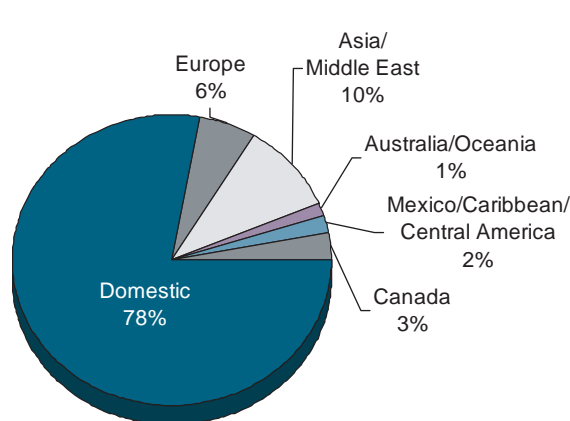

Source: San Francisco Airport Commission 2009, p. 20.

**Figure 14-4. Destination of passengers.**

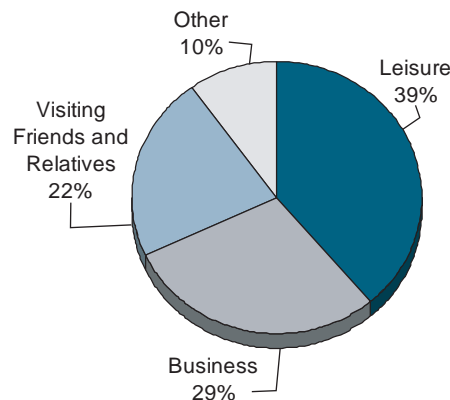

Source: San Francisco Airport Commission 2009, p. 20.

**Figure 14-5. Reason for travel.**

**Table 14-5. SFO concession sales and revenue—2008 (millions).**

	Domestic Terminals	International Terminal	Total Sales	Revenue to Airport
Food and Beverage	\$ 98.0	\$ 28.8	\$ 126.8	11.9
Convenience Retail	21.3	12.6	33.9	7.0
Specialty Retail	56.0	25.7	81.7	11.2
Subtotal	\$ 175.3	\$ 67.1	\$ 242.4	\$ 30.1
Duty Free	\$ 1.4	\$ 66.9	\$ 68.3	—
Passenger Services	n.a.	n.a.	36.0	3.8
Advertising	n.a.	n.a.	9.8	6.9
Currency Exchange	n.a.	n.a.	0.1	0.1
	\$ 176.7	\$ 134.0	\$ 356.6	\$ 40.9

Source: LeighFisher. Data from *Airport Revenue News Fact Book 2009* (Airport Revenue News 2009).

### 14.2.4 Estimated Sales and Revenue

Total concession sales by category for SFO's domestic and international terminals are summarized in Table 14-5.

Sales and revenue per enplaned passenger at SFO are summarized in Table 14-6 below.

SFO sales averaged \$11.70 per enplaned passenger for combined food and beverage, specialty retail, and convenience retail—the third highest average amount in the United States (after Pittsburgh and New York Kennedy Airports). SFO's overall food and beverage sales per enplanement are the highest in the nation. The airport received net revenue of \$1.62 per enplaned passenger from food and beverage, specialty retail, and convenience retail sales. International enplaning passengers spent an average of \$15.27 in duty free shops, which provided net revenue to the airport of \$4.06 per international enplaned passenger. Advertising sales of \$0.53 produced net revenue of \$0.37 net per enplaned passenger.

### 14.2.5 Concessions

At SFO, Food and beverage concessions include 65 units, 27 concessionaires, and 75,500 square feet of space. Food and beverage concessionaires include D-Lew Enterprises, which operates cafes

**Table 14-6. SFO sales and revenue per enplanement by category for domestic and international terminals—2008.**

	Sales per Enplanement			Revenue per Enplanement		
	Domestic Terminals	International Terminal	Total Sales	Domestic Terminals	International Terminal	Total
Food and Beverage	\$ 7.24	\$ 5.77	\$ 6.85	\$ 0.72	\$ 0.42	\$ 0.64
Convenience Retail	1.57	2.52	1.83	0.29	0.60	0.38
Specialty Retail	2.24	5.14	3.02	0.36	1.26	0.60
Subtotal	\$ 11.05	\$ 13.43	\$ 11.70	\$ 1.37	\$ 2.28	\$ 1.62
Passenger Services	n.a.	n.a.	\$ 1.94	n.a.	n.a.	\$ 0.21
Advertising	n.a.	n.a.	0.53	n.a.	n.a.	0.37
Currency Exchange	n.a.	n.a.	0.01	n.a.	0.02	0.00
	\$ 11.05	\$ 13.43	\$ 14.18	\$ 1.37	\$ 2.30	\$ 2.20
Duty Free (per In'l enplane)	\$ 2.25	\$ 17.39	\$ 15.27	\$ 0.58	\$ 4.63	\$ 4.06

Source: LeighFisher. Data from *Airport Revenue News Fact Book 2009* (Airport Revenue News 2009).

and two successful casual dining restaurants; the Bay Area Restaurant Group; Bayport Concessions; Boudin Sourdough bread; Gotham Enterprises, which operates several Firewood Cafés and Peet’s coffee kiosks; and local restaurants Andale, Ebisu, Osho, Sankaku, and San Francisco Soup Company. SSP America and HMS Host also operate at SFO, combining for about 22% of the total food and beverage space.

Retail at SFO includes 76 locations, 23 concession agreements, and 77,900 square feet of space. Convenience retail is operated by HMS Host, Hudson News, Pacific Gateway, and Paradies Shops. Local bookseller, Books, Inc., operates a major bookstore in Terminal 3 and will open one in the new Terminal 2. Specialty retail operators include Airport Wireless, Brookstone, B-zinc, Erwin Pearl, Ghirardelli Chocolates, Hudson Booksellers, InMotion Entertainment, MNG by Mango, Pacific Outfitters, San Francisco Museum of Modern Art (MOMA) Shop, Sunglass Hut, Techshowcase, and Tumi Luggage, among others.

Duty free at SFO includes 11 locations, one concession agreement, and 30,700 square feet of space. The duty free concessionaire is DFS Group, which operates two main shops totaling 22,000 square feet, as well as Coach and Gucci branded boutiques, two branded duty free kiosks, and two smaller “last chance” shops. DFS also either operates or subleases all post-security retail spaces, many of which are subleased to ACDBEs, including Pacific Gateway, which operates all of the post-security newsstands. DFS also operates two pre-security Sephora shops.

Services at SFO include checkpoint mailing facilities; a travel agency; a full-service banking center; laptop workstations; a hair salon; spas; a pharmacy; and a medical clinic that provides travel medicine, urgent care, immigration physicals, and occupational health services. The airport offers free Wi-Fi, which was formerly operated as a concession. Other amenities include family restrooms and showers. The SFO Kids’ Spot play area features interactive attractions for the Exploratorium of San Francisco. Travelex America, Inc., provides currency exchange and ATM services. Express Spa operates two locations.

Clear Channel Airports is the advertising concessionaire at SFO.

### 14.2.6 Terminal Configuration

The airport has four terminal buildings. Terminal 1 was built in the 1970s and has limited post-security space and an excess of pre-security concession space. Terminal 2, the oldest terminal at the airport, is undergoing a \$380 million reconstruction and will provide 14 additional domestic gates. The terminal opens in 2011 and will handle American Airlines and Virgin America, which is growing its San Francisco schedules. Terminal 2 is discussed later in this section. Terminal 3 handles a majority of the airport’s total passenger traffic. Concession space is almost entirely post-security. The International Terminal has 23 wide body gates on two concourses, each with its own security checkpoint. Arriving passengers in Terminal 3 can connect to one of the two concourses at the International Terminal through a secure connector, eliminating the need for an additional security inspection.

The configuration of the four terminals is shown in Figure 14-6.

Table 14-7 summarizes concession space by category, and Table 14-8 summarizes concession space per 1,000 enplaned passengers. Space in the domestic terminals is somewhat constrained, as the average of 6.2 square feet per 1,000 enplaned passengers includes considerable pre-security space in Terminal 1, which is of marginal utility. The airport is considering a series of improvements to increase the amount of concession space in Terminal 3, used by United Airlines, which has the highest spend rates on the airport.

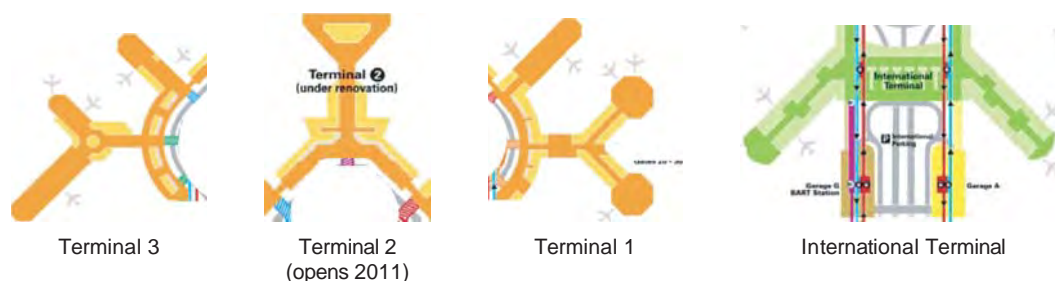

Source: Flysfo.com (As of October 10, 2010).

**Figure 14-6.** SFO terminal configuration.

### 14.2.7 Commercial Strategy

SFO has adopted a strategy to be the “airport of choice” for the Bay Area, which includes a focus on providing a quality customer experience. The airport utilizes the direct leasing approach and has one of the largest direct leasing programs in the United States.

SFO has favorable demographics for concessions, including passenger incomes higher than state and national averages; a mix of long-haul international passengers (22%); a large number of inbound and outbound leisure passengers, including tourists visiting San Francisco; and domestic long-haul passengers, including transcontinental and Hawaii passengers.

The airport views food and beverage as an essential customer service with quality and value taking precedence over revenue. Beginning in the late 1990s with the development of the concession program in the International Terminal (which opened in 2001), the airport made a major effort to attract local restaurateurs. Because it was a new terminal, the concessions at the International Terminal were not under the exclusive rights of the then-current master food and beverage agreement. The Airport Commission employed a developer to develop the food and beverage services based on (1) attracting local restaurants offering “the best of San Francisco” and (2) lowering the rent structure for food and beverage in recognition of the cost structure of smaller lease packages and the relatively high labor and other operating costs typical of the Bay Area. The program was a success, and a similar strategy was adopted for the domestic terminals in 2005 and implemented by the airport, with local businesses winning 80% of the spaces. ACDBEs won a 70% share. The local

**Table 14-7.** SFO concession space by category (square feet)—2008.

	Food and Beverage	Specialty Retail	Convenience Retail	Duty Free	Total
Domestic Terminals	51,517	26,265	10,745	470	88,997
International Terminals	23,983	31,187	8,712	30,216	94,098
	75,500	57,452	19,457	30,686	183,095
Percent by category	41%	31%	11%	17%	100%

Source: LeighFisher. Data from *Airport Revenue News Fact Book 2009* (Airport Revenue News 2009).

**Table 14-8.** SFO concession space per 1,000 enplaned passengers (square feet)—2008.

	Food and Beverage	Specialty Retail	Convenience Retail	Duty Free	Average per terminal
Domestic Terminals	3.6	1.8	0.7	0.0	6.2
International Terminals	5.8	7.5	2.1	7.3	22.6
Average—all airports	4.1	3.1	1.0	1.6	9.8

Source: LeighFisher. Data from *Airport Revenue News Fact Book 2009* (Airport Revenue News 2009).



operators have proven popular, with food and beverage sales per enplaned passenger increasing by 40% immediately after the transition from the master concessionaire to the predominately local program. Since this program was implemented, the airport has had the highest food and beverage sales per enplaned passenger in the United States.

### 14.2.8 Unique Concessions and Innovations

#### *New Terminal 2*

In September 2008, SFO broke ground on a \$383 million project to renovate Terminal 2 in order to accommodate growth in passenger traffic and airline demand for gates. This state-of-the-art, environmentally friendly domestic terminal is expected to open in the second quarter of 2011. Terminal 2 will have capacity for 5.5 million annual enplaned passengers and will handle a projected 3.2 million enplaned passengers in its first year of operation.

Terminal 2 will have 14 gates expected to serve predominantly narrow-body aircraft, but with the capability of accommodating a Boeing 747-400 sized aircraft. Terminal 2 will feature nearly 30,000 square feet of retail development, including restaurants, retail stores, and a gourmet marketplace and serve American Airlines and Virgin America. The new concessions program features 29,909 square feet of retail development, including 12 eating establishments and a retail street traveled by all departing and arriving passengers (see Figure 14-7 for the Terminal 2 concession plan). Key elements of the plan include the following:

- Napa Farms Market will feature a cheese counter, a bakery, a wine bar, and possibly locally grown fresh fruit and vegetables.
- Vegan, organic, and gluten-free selections will be featured at The Plant Café Organic, a counter service location.
- Health-conscious Northern California dishes will be highlighted at The Grill by Lark Creek, a table service restaurant. This will also be the first airport dining terminal in the United States to offer a “slow food” focus, meaning it will be approved by Slow Food USA.
- Four other quick-serve locations, a bar/lounge, and two specialty coffee locations are integrated with common holdroom seating areas, offering a range of seating options with amenities including power outlets. The seating types are intended to encourage passengers to eat and drink near the departure gates.
- Eight specialty retail shops will offer fashion and accessories, artwork and collectibles, jewelry and accessories, books, chocolates, premium souvenirs, technology, and travel accessories.

#### *Health and Environmental Policy*

New food vendors are encouraged to comply with a 16-point health and environmental policy including use of the following: appropriate portion sizes, visible food preparation areas, low- or no-phosphate detergents, organic agricultural products from the Northern California region, and sustainable seafood and products.

#### *Sustainability*

Sustainable design elements figure prominently. The airport is seeking LEED Silver certification for Terminal 2 and expects concessionaires to meet this standard also.

## 14.3 Tulsa International Airport

### 14.3.1 Ownership/Governance

Tulsa International Airport (TUL) is owned by the City of Tulsa, Oklahoma. It is operated by the Tulsa Airport Authority (Authority), a charter authority of the City established to administer,



Source: San Francisco Airport Commission 2009, p. 20.

**Figure 14-7. Terminal 2 concession plan.**

manage, and operate TUL and Riverside/Richard Lloyd Jones, Jr. Airport. The Authority's policy-making body is a five-member Board of Trustees (Board), known as the Tulsa Airport Improvements Trust (TAIT). The Mayor and four qualified voters of the City of Tulsa make up the Board.

### 14.3.2 Traffic Overview

TUL ranked 74th in enplaned passengers in 2009. The airport reported nearly 1.6 million enplaned passengers. Traffic has been declining slightly since the peak year of 2001.

TUL boasts non-stop service to 15 cities in the United States and is served by American Airlines, Continental, Delta, Southwest, and United. Southwest has the largest market share with almost 34% of enplaned passengers, followed by American Airlines with 26% and Delta Air Lines with 15%.

### 14.3.3 Passenger and Market Characteristics

TUL is an origin and destination (O&D) airport. Almost all of its passengers are domestic arriving and departing passengers. Connecting passengers are less than 1% of the total. According to the airport's most recent survey of arriving and departing passengers, conducted in April and May of 2010, respondents were 54% male and 46% female. A little over half of them, 51%, were under age 40, and 49% were over age 40.

### 14.3.4 Estimated Sales and Revenue

According to a recent *Tulsa World* article, passenger revenue from restaurants, newsstands, and gift shops has nearly doubled at TUL in the past 10 years to \$10.2 million. Sales per enplaned passenger in 2008 were \$6.40, nearly twice the \$3.33 per enplaned passenger a decade ago (Stewart 2010). Table 14-9 summarizes gross and net revenue and gross and net revenue per enplaned passenger, as well as concession space and space per 1,000 enplaned passengers by category.

TUL's sales per enplaned passenger increased sharply after the terminal reconfiguration and development of the new concession program. From 2004 to 2008, TUL's sales per enplaned passenger increased by 78%, more than twice as fast as the rate of growth of airports with annual enplaned passengers between 1 million and 2 million, which grew by 38% over this period.

### 14.3.5 Concessions

For the second year in a row, TUL's concession program was ranked one of three "among the best" for food and retail services in the small airport category by a recent J.D. Power and Associates airport passenger satisfaction study.

**Table 14-9. Sales, revenue, and space (Tulsa International Airport)—2008.**

	Sales (millions)	Sales per enplanement	Revenue (millions)	Revenue per enplanement	Space (sq ft)	Space per 1,000 Enplanements
Food and Beverage	\$ 5.540	\$ 3.48	\$ 0.589	\$ 0.37	14,500	9.1
Specialty Retail	1.565	0.98	\$ 0.219	\$ 0.14	4,000	2.5
Convenience Retail	3.084	1.94	\$ 0.376	\$ 0.24	5,200	3.3
	\$ 10.189	\$ 6.40	\$ 1.184	\$ 0.74	23,700	14.9

Source: LeighFisher. Data from *Airport Revenue News Fact Book 2009* (Airport Revenue News 2009).

Food and beverage concessionaire and concepts include the following: HMS Host (Camille's; Cherry Street Grill; Starbucks; TGI Friday; Varsity Grill).

Retail concessionaire and concepts include the following: The Paradies Shops (Explore Tulsa; Novel Idea Bookstore; Cherry Street Travel Mart; CNBC News; Green Country Marketplace).

A full-service hair salon/barbershop is on the upper level of the center terminal, pre-security. There are pay phones throughout the terminal and shoeshine service on both concourses near the airline gates. ATM machines are located pre-security, near the security checkpoint and ticketing lobby, and post-security in Concourses A and B. For those requiring business services, TUL features a series of meeting rooms located throughout the terminal, which are available for rent. There is free Wi-Fi service for AT&T customers who have Wi-Fi included in their AT&T plans. Others can purchase a 24-hour Wi-Fi session.

Advertising concessionaire: Interspace Advertising.

### 14.3.6 Terminal Configuration

Unlike most terminals, the Tulsa airport terminal has a split roadway with departures curbside on the lower level and arrivals curbside on the upper level. There are two departure concourses with a single, central security checkpoint. From the security checkpoint passengers enter a long connecting corridor overlooking the aircraft ramp connecting the two concourses. Concessions are on one side of the connector. There are additional food and beverage and retail concessions on the concourses. The terminal configuration is shown on Figure 14-8.

### 14.3.7 Commercial Strategy

The Authority's commercial strategy, implemented over several years, has had multiple elements including the following:

- Reconfiguring and remodeling the terminal building
- Creating a single security checkpoint that consolidated two separate departing passenger flows

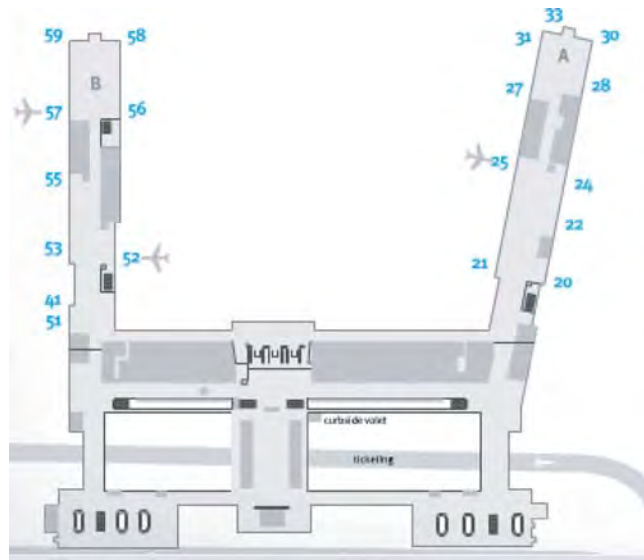

Source: Tulsa Airport Authority. <http://www.tulsaairports.com/index.cfm?id=20>. Accessed November 10, 2010.

**Figure 14-8.** Terminal layout (Tulsa International Airport).

- Developing more post-security space to take advantage of the consolidated passenger flow
- Emphasizing local brands and, in particular, local events to create a sense of place

Before the recent terminal addition, the airport had two security checkpoints at the entrance to each concourse. Adjacent to the checkpoints were small, traditional news/gift shops. Food and beverage services, including a self-service cafeteria and a small bar, were located in the center of the terminal out of the departing passenger flows. After security, each concourse had a combination quick-service restaurant with an adjacent bar, and a news/gift shop, as well as a kiosk or additional in-line specialty retail unit.

The airport recognized an opportunity to expand the concession program when it undertook a project to enclose new space at the apron side of the terminal between the two concourses to accommodate in-line baggage screening equipment on the ground level. By enclosing the space above the addition, a concession mall was created that featured a window wall overlooking the airfield on one side and concessions on the other. The two checkpoints at entrances to the concourses were consolidated into a single checkpoint in the center of the terminal, creating a single passenger flow into the concession area. The single passenger flow, by consolidating passengers, was the key to adding the additional terminal locations and providing sufficient passenger volumes to support the individual units. Figure 14-9 presents a view of the post-security connector and concession mall.

Near the time that the terminal development was being planned, the existing single, long-term master concession agreement was expiring, which allowed the Authority to award new concession contracts. A new concession plan was developed, and a contracting strategy was developed. One retail agreement and one food and beverage agreement were awarded. Each contract encouraged subleasing with local brands or licensing local brands to add local flavor to the program.

TUL's sales per enplaned passenger increased sharply after the terminal reconfiguration and development of the new concession program. From 2004 to 2008, TUL's sales per enplaned passenger increased by 78%, more than twice as fast as the rate of growth of airports with enplaned passengers of 1 million to 2 million, which grew by 38%. The program also had a major effect on the perception of the airport and the terminal.

### 14.3.8 Unique Concessions and Innovations

#### *Recycling*

All trash generated at the TUL terminal and satellite facilities are sent to an “energy from waste” facility. There, the trash is burned and the steam is recaptured and converted to electrical



**Figure 14-9.** *Post-security connector and concession area (Tulsa International Airport).*



energy, which is sold to area refineries. This reduces the Airport's landfill usage by 90%. Coffee grounds from Starbucks are used by grounds crews for compost and the airport's ornamental flower gardens.

### *Sense of Place*

Like many airports, TUL made a concerted effort to create a theme that conveyed a sense of place or destination. TUL, however, distinguished itself by selecting a theme that is a continuous celebration of the community's eclectic events. The themes evolved from extensive community involvement, many meetings, and other opportunities for input into their development.

TUL held a concession fair a year in advance of the due date for proposals for the concession opportunities. The advance notice provided interested parties with the opportunity for teaming, researching, and developing their proposals and creating a plan for delivering the unique requirement for a revolving sense of place. Interest in the program was very high, and TUL is quite pleased with the results following the competitive award of the concession privileges.

Food and retail operators refresh their units 12 times a year to reflect the event being celebrated or promoted, such as golfing events, basketball tournaments, May Fest, and others. The TUL marketing group creates the themes and, in some instances, generates additional revenue for the airport in the process. Renting space for products being offered at an event or promoting an event has been profitable for TUL.

## **14.4 Portland International Airport**

### **14.4.1 Ownership and Governance**

Portland International Airport (PDX) is governed by the nine-member Port of Portland Commission, which is appointed by the Governor of Oregon and ratified by the Oregon Senate. Commissioners serve a 4-year term and can be reappointed. At least two of the Commission members must live in each one of the three counties in the Port district. The remaining members may live in any part of the State of Oregon. The Commission appoints the Port's Executive Director.

The Aviation Director is hired by the Port's Executive Director. The Aviation Director is responsible for overseeing the day-to-day management of the Airport and for the planning, development, and implementation of airport projects.

### **14.4.2 Traffic Overview**

In 2009, PDX was the 30th busiest airport in the United States based on passenger boardings, with 6.4 million enplaned passengers. PDX is served by 13 airlines with direct service to many domestic locations, as well as locations in Canada, Mexico, the Netherlands, and Japan. The airport is a major hub for Alaska Airlines and Horizon Air, as well as for the United Express affiliate, SkyWest Airlines. In addition, Seaport Airlines, a regional carrier, is headquartered at PDX.

### **14.4.3 Passenger and Market Characteristics**

Approximately 86% of the airport's passengers begin or end their trip at PDX. Because it is the primary airport in Oregon and is close to Portland, which is Oregon's most populated city, the airport serves a large majority of the state's air travelers. The *Airport Revenue News Fact Book 2009* shows that the ratio of business to leisure travelers is 32/58 (Airport Revenue News 2009).



**Table 14-10. Annual concession sales by category—2008.**

	Sales (millions)	Net revenues (millions)
Food and beverage	\$ 40.4	\$ 4.3
Specialty retail	18.2	2.1
Convenience retail	16.1	2.2
<b>Totals</b>	<b>\$ 74.7</b>	<b>\$ 8.6</b>

Source: LeighFisher. Data from *Airport Revenue News Fact Book 2009* (Airport Revenue News 2009).

The U.S. Census Bureau State and County Quick Facts show that Oregon has a population of approximately 3.8 million people (U.S. Census Bureau 2010). Approximately 64% of the state's population is between the ages of 18 and 64. The median household income in Oregon is approximately \$50,000.

#### 14.4.4 Estimated Sales and Revenue

Total in-terminal concession sales and net revenue to the airport totaled \$74.7 million in 2008, as shown in Table 14-10.

PDX had approximately 300,000 enplaning international passengers in 2008, of which approximately 200,000 used Terminal D. Table 14-11 shows the variation in food and beverage and retail spend rates by terminal, excluding duty free. The terminal with the most international passengers had the highest spend rate among the airport's five concourses. The airport achieved average sales per enplaned passenger in 2008 of \$10.44, the fifth highest of all U.S. airports reporting data to ARN for 2008, behind Pittsburgh International Airport, New York John F. Kennedy International Airport, San Francisco International Airport, and Newark Liberty International Airport. PDX ranked second after Pittsburgh International Airport among medium hub airports.

**Table 14-11. Enplaned passengers, sales, and sales per enplaned passenger by terminal area (Portland International Airport)—2008.**

Terminal Area	Enplaned passengers				Food and beverage and retail sales		
	Domestic	International	Total	Share	Sales	Share	Sales per enplaned passenger
Concourse A	1,101,269	49,791	1,151,060	16.1%	\$ 3,130,509	4.2%	\$ 2.72
Concourse B	311,713	0	311,713	4.3%	829,347	1.1%	\$ 2.66
Concourse C	3,124,377	12,278	3,136,655	43.9%	17,478,880	23.4%	\$ 5.57
A, B, C Common Areas	—	—	—	—	8,962,163	12.0%	\$ 1.95
<b>Total Terminal</b>	<b>4,537,359</b>	<b>62,069</b>	<b>4,599,428</b>	<b>64.3%</b>	<b>\$ 30,400,899</b>	<b>40.7%</b>	<b>\$ 6.61</b>
Concourse D	1,279,500	204,015	1,483,515	20.7%	\$ 8,565,299	11.5%	\$ 5.77
Concourse E	1,022,817	45,097	1,067,914	14.9%	3,440,664	4.6%	\$ 3.22
D and E Common Areas	—	—	—	—	1,149,366	1.5%	\$ 0.45
D,E Totals	2,302,317	249,112	2,551,429	35.7%	\$ 13,155,329	17.6%	\$ 5.16
<b>Total - Post Security</b>	<b>6,839,676</b>	<b>311,181</b>	<b>7,150,857</b>	<b>100.0%</b>	<b>\$ 43,556,228</b>	<b>58.3%</b>	<b>\$ 6.09</b>
Bag Claim					\$ 909,693	1.2%	\$ 0.13
Main Terminal (Oregon Market)					\$ 30,203,529	40.4%	\$ 4.22
<b>Total - Pre Security</b>					<b>\$ 31,113,222</b>	<b>41.7%</b>	<b>\$ 4.35</b>
<b>Grand Total</b>					<b>\$ 74,669,450</b>	<b>100.0%</b>	<b>\$ 10.44</b>

Source: LeighFisher. Data from *Airport Revenue News Fact Book 2009* (Airport Revenue News 2009).

The Oregon Market is located after the ticket counters and before the security checkpoints and features many local, regional, and national concepts. PDX has instituted a street pricing policy for its food/beverage and retail concessions. Sales at PDX are tax free, as Oregon is one of the few states in the nation that does not impose a sales tax.

#### **14.4.5 Concessions**

PDX offers a wide range of pre-security and post-security dining and retail shopping and services options.

There are 36 food and beverage units with 21 different concepts. Food and beverage concessions include Baskin Robbins; Beach's Restaurant and Bar; Beaverton Bakery; Big Town Hero; Capers Café; Coffee People; Flying Elephant Deli; Good Dog, Bad Dog; Gustav's Pub and Grill; Jamba Juice; Laurelwood Brewing Co.; Panda Express; Pizza Schmizza; Pizzicato; Riverfront Café; Rogues Ales Public House; Rose's Restaurant and Bakery; Sandovals Fresh Mexican Grill; Stanford's Restaurant and Bar; Starbucks; and Wendy's.

There are 32 retail units with 15 different concepts. Retail concessions include Aria Boutique, Brookstone, cc McKenzie Shoes and Apparel, Columbia Sportswear, Creative Kidstuff, Hudson News, InMotion Entertainment, Made in Oregon, Nike, Oregon Pendleton Shop, Powell's Book Store, Real Mother Goose, Rosetta Stone, Spirit of the Red Horse, and Your Northwest Travel Mart.

Services include a bank with ATMs throughout the terminal (US Bank), a barbershop (The Barbers), two business service centers (Travelex), the Oregon Lottery, luggage carts (Smarte Carte), two full-service spas (The Dragontree Spa), and free Wi-Fi.

In-terminal advertising is provided through Alliance Airport Advertising.

#### **14.4.6 Terminal Configuration**

PDX has an H-shaped terminal with five concourses (see Figure 14-10). The south side concourses (A, B, and C) are connected to the north side concourses (D and E) beyond PDX's two security checkpoints by an elevated walkway that opened in August 2005. The Oregon Market, with its many restaurants and shops, is located behind the airline ticket counters and is accessible to passengers and visitors alike.

Concourse A contains five gates and Concourse B contains three gates, all of which are on the south side of the terminal. The 23 gates in Concourse C occupy both sides of the concourse, thus providing the concessions on the concourse with exposure to passengers at more gates.

Concourses D and E are on the north side of the terminal. Concourse D includes 15 gates, which, like Concourse C, are situated on both sides of the concourse. Concourse E includes seven gates on the north side of the concourse only.

PDX has almost 77,000 square feet of food and beverage, convenience retail, and specialty retail concession space, as shown in Table 14-12.

#### **14.4.7 Commercial Strategy**

PDX has long been considered an innovator and leader in terms of concession program quality and performance. Beginning with its flagship Oregon Marketplace development in 1988, the Port of Portland used its concession program as a way of differentiating the airport from others, creating an identity that reflected the local community, and incorporating established local food and beverage concepts such as Beaverton Bakery, Pizza Schmizza, Laurelwood Public House and

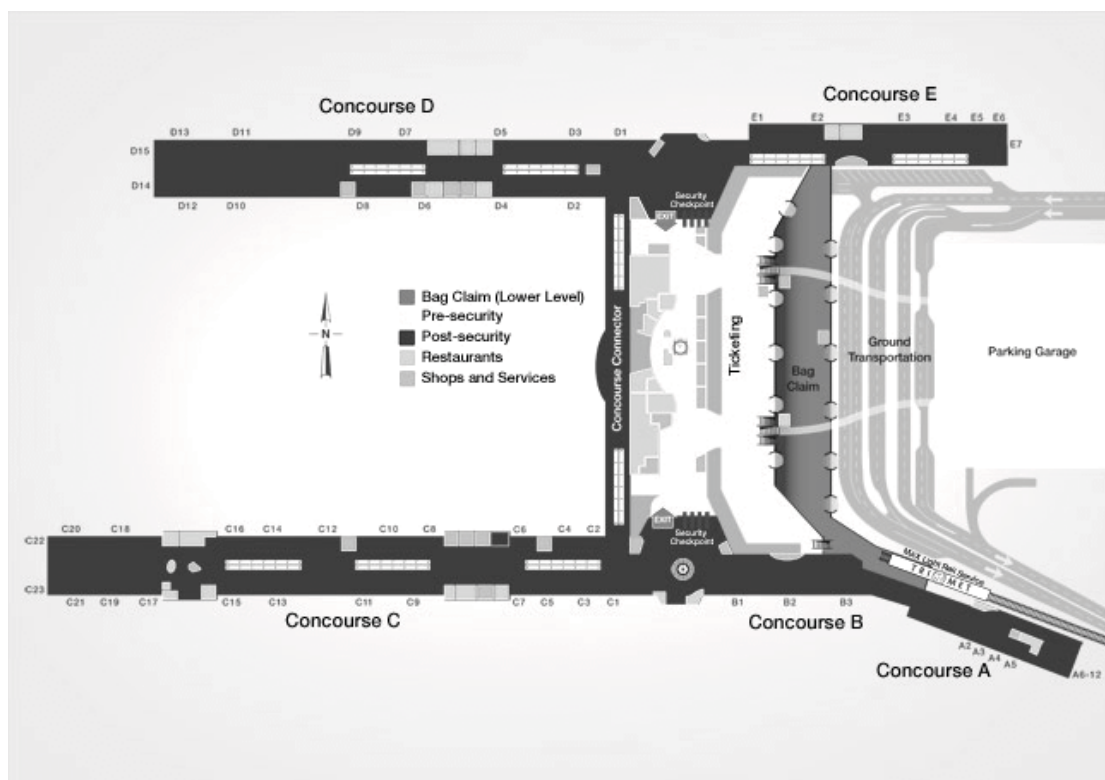

Source: Port of Portland.

**Figure 14-10. Terminal layout (Portland International Airport).**

**Table 14-12. Concession space and concession space per 1,000 enplaned passengers by terminal area (Portland International Airport)—2008.**

Terminal Area	Food and beverage and retail square feet				Enplaned passengers	Square feet per 1,000 enplaned passengers
	Food and Beverage	Specialty retail	Convenience retail	Total square feet		
Concourse A	1,944	—	435	2,379	1,151,060	2.1
Concourse B	215	—	389	604	311,713	1.9
Concourse C	11,132	2,850	1,382	15,364	3,136,655	4.9
A, B, C Common Areas	3,847	983	1,150	5,980		1.3
<b>Total Terminal</b>	<b>17,138</b>	<b>3,833</b>	<b>3,356</b>	<b>24,327</b>	<b>4,599,428</b>	<b>5.3</b>
Concourse D	5,702	1,544	2,039	9,285	1,483,515	6.3
Concourse E	2,826	—	700	3,526	1,067,914	3.3
D and E Common Areas	855	—	—	855		0.3
<b>D,E Totals</b>	<b>9,383</b>	<b>1,544</b>	<b>2,739</b>	<b>13,666</b>	<b>2,551,429</b>	<b>5.4</b>
<b>Total - Post Security</b>	<b>26,521</b>	<b>5,377</b>	<b>6,095</b>	<b>37,993</b>	<b>7,150,857</b>	<b>5.3</b>
Bag Claim	485	—	485	970	7,150,857	0.1
Main Terminal (Oregon Market)	23,947	12,169	1,830	37,946	7,150,857	5.3
<b>Total - Pre Security</b>	<b>24,432</b>	<b>12,169</b>	<b>2,315</b>	<b>38,916</b>	<b>7,150,857</b>	<b>5.4</b>
<b>Grand Total</b>	<b>50,953</b>	<b>17,546</b>	<b>8,410</b>	<b>76,909</b>	<b>7,150,857</b>	<b>10.8</b>

Source: LeighFisher. Data from *Airport Revenue News Fact Book 2009* (Airport Revenue News 2009).

Brewery, and local retail brands. Locally based national brands, such as Nike, Norm Thompson, and Columbia sportswear, are prominent.

Concession design is coordinated with design of the surrounding terminal areas to create a cohesive and inviting visual appearance. Stores are clustered in strategic locations to maximize convenience to the travelling public and maximize sales.

Strong customer service is a key ingredient of the PDX commercial strategy. PDX conducts surveys at regular intervals to gauge the needs of customers and evaluate performance. As an example, the Port of Portland's Summer 2008 Publication *Portside* states that "the average PDX visitor flies four times a year, spends 100 minutes in the terminal, has a strong preference for local products, values a quick purchase, and cares about pricing" (Port of Portland 2008, p. 2). This type of information is used by PDX in determining how to structure its concession program and in tenant selection.

All airport shops and restaurants must comply with the airport's "street retail pricing policy" whereby prices charged to the customers must be no greater than prices for similar products at designated off-airport locations. This provides value and pricing consistency to concession customers at PDX. Wi-Fi access throughout most of the airport is free.

PDX operates its concessions under a "direct leasing" strategy whereby the airport contracts directly with a variety of concessionaires. PDX made the commitment to invest the extra staff time and energy associated with the direct leasing approach with the expectation that it would provide the airport with a greater degree of control over the concession program and produce optimum results. This approach has worked well as evidenced by the high sales numbers and consistent accolades from customers and the industry.

The success of PDX's commercial strategy is exemplified in its ranking by Condé Nast *Traveler* magazine as the Best Domestic Airport in four of the last five years (Baskas 2010).

#### **14.4.8 Unique Concessions and Innovations**

PDX is one of the few U.S. airports that has successfully implemented strong pre-security concessions program. Oregon Market, located after the ticket counters, hosts a strong set of concession concepts and is accessible to travelers, employees, meeters and greeters, well-wishers, and others visiting the airport.

Spring Fling, Summer Splash, and Holiday Take Flight promotional events occur during the busiest travel periods annually. These events include sidewalk sales, product samplings, and other special events. Colorful signs and displays are used in the terminal to promote the events. Drawings for airline tickets are a featured part of these marketing events.

PDX is an airport leader in sustainability. PDX has solar panels on the terminal roof providing power to the Nike store; free compostable "shop, dine, and fly" shopping bags; and an extensive program to turn food waste into compost for beneficial use. PDX's commitment to the environment is exemplified by its receipt of ACI-NA's 2010 Outreach, Education, and Community Involvement Award for its Airport Futures Project under which the Port of Portland, the City of Portland, and the Portland-Vancouver communities worked together to create a long-term airport master plan and city-use plan for PDX that incorporates community values and integrates sustainability principles.

### **14.5 Amsterdam Schiphol International Airport**

Amsterdam Schiphol Airport (AMS) is the fourth busiest airport in Europe and one of two hubs for KLM/Air France. AMS has been aggressive in developing its concessions for decades,

long before the commercialization trend began in the late 1980s, using a single terminal, pier/finger concept to encourage transfer passengers and to create a major tax and duty free shopping opportunity.

### 14.5.1 Ownership/Governance

Amsterdam Schiphol Airport (AMS) is owned and operated as a subsidiary of the Schiphol Group, which also operates other commercial airports in the Netherlands including Rotterdam the Hague Airport, Lelystad Airport, and Eindhoven Airport. AMS is run as an independent commercial company. Plans to privatize the airport were abandoned in 2007.

Schiphol Group is owned by the Kingdom of the Netherlands (70%), the Municipality of Amsterdam (20%), Aéroports de Paris (8%), and the Municipality of Rotterdam (2%). Schiphol Group has a corresponding 8% interest in Aéroports de Paris, with which it established a strategic alliance after the merger of Air France and KLM airlines. Schiphol Group is overseen by a Supervisory Board and managed by a senior management team that includes a Chief Executive Officer, a Chief Operating Officer, a Chief Financial Officer, and a Chief Commercial Officer, who oversees the consumer (retail) and real estate business areas.

Schiphol Group also has ownership stakes in Terminal 4 at New York's John F. Kennedy Airport (40%) and Brisbane (Australia) Airport (18.7%) and interests in various cargo, logistics, and real estate and development companies.

### 14.5.2 Traffic Overview

AMS handled 43.5 million passengers in 2009. It is the fifth busiest airport in Europe and served 284 destinations in 93 countries and 92 scheduled airlines.

The top European and intercontinental destinations are shown in Table 14-13.

### 14.5.3 Passenger and Market Characteristics

Passengers' reasons for travel are a mix of leisure and business travel, as shown in Figure 14-11.

The nationalities of its passengers reflects AMS's role as a connecting airport that draws from the surrounding region, as shown in Figure 14-12. Only 33% of passengers are from The Netherlands.

The average departing passenger spends more than 2 hours (140 minutes) at the airport, including 27 minutes in the landside area, 57 minutes in the departures area, and 56 minutes at the departure gate. Passengers are 61% male and 39% female.

**Table 14-13. Top 10 destinations (Amsterdam Schiphol Airport).**

	Europe	Intercontinental
1	London	Detroit
2	Barcelona	New York
3	Paris	Minneapolis
4	Madrid	Hong Kong
5	Copenhagen	Bangkok
6	Rome	Curacao
7	Munich	Nairobi
8	Zurich	Singapore
9	Frankfurt	Toronto
10	Milan	Kuala Lumpur

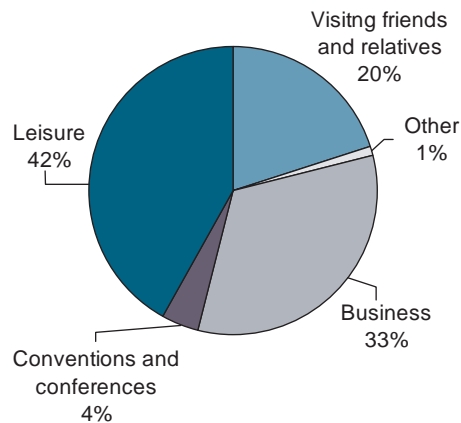

Source: These data have been published by Amsterdam Airport Schiphol in *Traffic Review 2009* (Amsterdam Airport Schiphol 2010).

**Figure 14-11. Reason for travel (Amsterdam Schiphol Airport).**

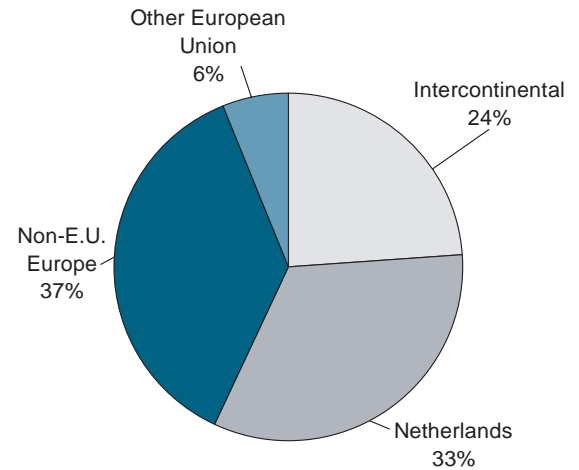

Source: These data have been published by Amsterdam Airport Schiphol in *Traffic Review 2009* (Amsterdam Airport Schiphol 2010).

**Figure 14-12. Nationality of passengers (Amsterdam Schiphol Airport).**

#### 14.5.4 Estimated Sales and Revenue

As is the practice of most corporatized or privatized airports in the European Union, the airport does not disclose concession sales and revenue data. However, the duty and tax free See/Buy/Fly shops in the post-security area had estimated sales of \$475 million and average sales per departing international passenger of \$21.79, according to the 2010/2011 *Duty Free and Travel Retail Database and Directory* (Duty Free News International 2011). The airport earned net revenue of \$79 million on these sales or \$7.35 per departing international passenger. Until 2007, KLM operated the duty free shops, except for the perfume and cosmetics category. In 2007, the airport took over operation of the majority of duty free shops from KLM, which increased net revenue by \$93 million, according to the airport.

#### 14.5.5 Concessions

The pre-security Schiphol Plaza area has a total of 42 shops and 24 food and beverage outlets. In the post-security area, there are 79 shops and 52 food and beverage outlets.

Duty free shops are Schiphol Airport Retail and Kappé (perfumes & cosmetics).

Food and Beverage concessionaires are HMS Host (61 units) including Bubbles Seafood & Wine Bar, Burger King, Café Amsterdam, Café Chocolat, Café Ellipse, Café Rembrandt, Constellation Bar, Food Village, GrabandFly, Grand Café Het Paleis, Haagen Dazs, Juggle Juice Bar, Multivlaai, Per Tutti, Murphy's Irish Pub, Nautilus Café, Network Bar, Restaurant in de Bonte Koe, Shirasagi, Starbucks, Sushi Bar, Sports Café, and Vlaamse Frites.

Retail concessionaires include AKO, America Today, Aviflora, BLOEM, Capi, Crocs, Expo, Fleuratiek, Global Brands, Gassan Plaza, H&M, Hema, Leonidas, Lindessa, Mexx, Nike, Salotto, Sissy Boy Homeland!, Suitsupply, The Body Shop, and Wonder Woman.

#### 14.5.6 Terminal Configuration

The terminal was developed to support the KLM route network and facilitate transfer traffic. Metropolitan Amsterdam has a population of only about 2.2 million, and The Netherlands has a pop-



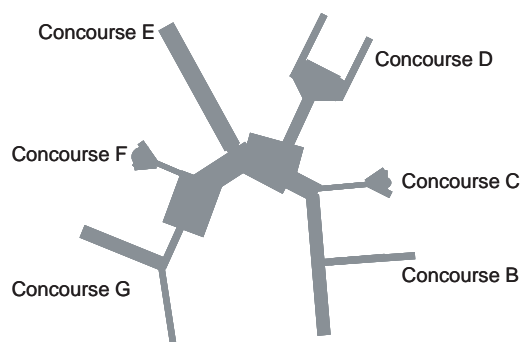

Source: LeighFisher.

**Figure 14-13. Terminal configuration (Amsterdam Schiphol Airport).**

ulation of only 16.5 million. Therefore, there is not a connecting network of domestic routes. The airport adheres to a single terminal development philosophy, with all concourses connected to a main terminal building housing the concession areas. The terminal layout is shown in Figure 14-13.

The airport has over 300,000 square feet of concession space, as shown in Table 14-14. AMS has an extensive landside retail development called Schiphol Plaza, which serves the large number of on-airport employees who commute to work, rail passengers, meeters and greeters, farewellers, and others. There are several office commercial office buildings in the terminal area that contribute to the demand.

### 14.5.7 Commercial Strategy

AMS has long been a leader in airport concessions. It was the first airport in mainland Europe to have duty free shops (Shannon, Ireland, was first in Europe).

The airport competes with nearby regional airports for traffic within Europe and competes with major European hubs for long-haul international traffic. To encourage transfer traffic, the terminal was designed to allow easy transfers, and the airport was aggressive in developing concessions that featured attractive pricing. The terminal design features utilitarian concourses connected to a terminal with a large post-security circulation area that includes an extensive array of shops and restaurants. The departure gates have secondary baggage drops that allow passengers to check oversized purchases.

The rail station at the airport has regular service throughout Holland and high-speed rail service to Rotterdam, Antwerp, Brussels, Paris, Berlin, Hannover, and other cities in the region, which extends the airport's air service area. AMS has a sizeable landside program, Schiphol Plaza, targeting the large numbers of terminal employees, returning O&D passengers, visitors, rail passengers,

**Table 14-14. Concession space.**

	Concession Space (sq ft)	Percent	Space per 1,000 Enplanements
Pre-security	194,218	62%	8.9
Post-security	118,360	38%	5.4
	312,578	100%	14.3

Source: Schiphol Group 2010.

and employees working in the terminal and adjacent landside commercial office buildings. The airport is exempt from restrictions on local shop hours.

The post-security duty and tax free shops are branded See/Buy/Fly with a distinctive blue logo on a bright yellow background. AMS has resisted the trend of branding airside shops. Like a department store, the airport shops are mostly generic shops selling a category such as “electronics” or “fashion.” However, the airport is expected to add some branded shops in the future. Many of the shops in Schiphol Plaza are branded, including H&M, Esprit, Nike, The Body Shop, and Mexx.

Food and beverage shops are distributed around the terminal, but most of the larger units are located on a mezzanine level. This preserves valuable departures-level space for more lucrative duty free and retail concessions.

### 14.5.8 Unique Concessions and Innovations

Some recent concession innovations at AMS include the following:

- A high-end cognac shop, L’Essence de Courvoisier, offering premium cognac. The shop also has a diamond promotion with a local jeweler.
- The opening in two locations in the departures area of Xpress Spa, the U.S. concessionaire.
- 2008 opening of Vizzit and since then opening of several Vizzit shops in the departures area. Vizzit is a shop featuring the airport’s best selling products, including liquor, perfume, cosmetics, souvenirs, snacks, and promotions.
- Opening of Jill & James, a landside shop combining a range of services including post office, drugstore, dry cleaners, shoe repair, clothing alterations, ATM, and employment agency.
- Privium, a membership service offered to frequent flyers that provides expedited security screening, use of business class check-in counters, iris screening and expedited international arrivals inspection, use of a dedicated lounge, and shopping discounts at duty free and other retail shops, with special discounts and promotions for members.
- The Holland Casino, located post-security, and open to passengers over 18 with a boarding pass. Lockers are provided for hand baggage.

One innovation is Schiphol Group’s development of a proprietary quality-of-service monitoring system called Airport I.Q. Monitor, a tool for measuring customer satisfaction. The airport conducts in-person interviews of departing and arriving passengers several times each year during peak, low, and shoulder seasons. The sample size takes into account all of the major airport user groups. Airport I.Q. Monitor is used to monitor a full range of airport-provided and contract services, including concessions, and this monitoring can in some cases result in incentive payments to or penalties for concessionaires.

Another innovation is the inclusion in the terminal of an art museum affiliated with the Amsterdam Rijksmuseum, which features rotating exhibits of Dutch masters’ paintings.

## 14.6 Seoul Incheon International Airport

Incheon International Airport (ICN) is the primary international airport serving Seoul and is the principal international gateway to Korea. The airport has been named “world’s best airport” in the ACI-World Airport Service Quality survey for the past 5 years (Incheon International Airport Corporation 2010, p. 13).

ICN is positioning itself to become a connecting hub for North Asia and is developing an extensive route network into China. ICN is highly commercialized and one of the top three airports in the world in terms of concession sales and revenue, taking full advantage of originating Korean passengers and their strong appetite for duty free products.

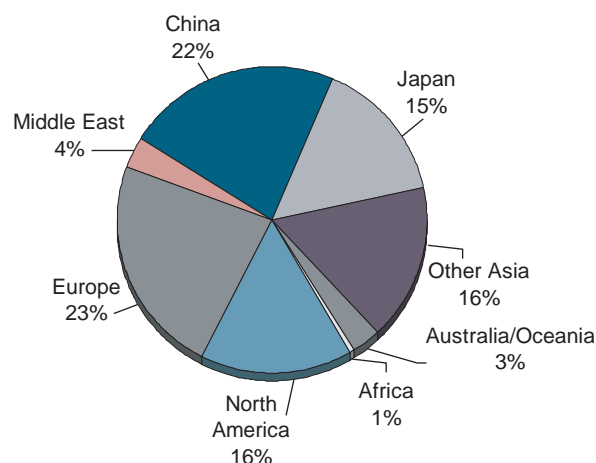

Source: Incheon International Airport Corporation 2010.

**Figure 14-14. Destinations by world region 2009 (Seoul Incheon International Airport).**

### 14.6.1 Ownership/Governance

ICN is owned and operated by Incheon International Airport Corporation (IIAC), which is wholly owned by the government. The government has plans to sell up to a 49% share to a strategic investor that can help it accomplish its ambitious plan to grow connecting air service. Passenger destinations by world region are shown in Figure 14-14.

### 14.6.2 Traffic Overview

ICN handles 72% of Korea's total inbound and outbound passengers. The airport opened in 2001 as the primary international airport serving Seoul. International airline operations were transferred from Gimpo Airport (SEL) to ICN upon opening, and SEL became a domestic airport. SEL today has a small number of short-haul international flights, mainly to Japan, while ICN handles a small number of domestic flights that account for less than 2% of total passengers.

In 2010, the airport was expected to handle an estimated 30 million annual passengers. ICN hosts 70 airlines serving 170 destinations in 60 countries. The airport serves more than 38 cities in China and 26 cities in Japan. According to reports, ICN serves more cities in Japan than Narita airport and more cities in China than Hong Kong airport.

### 14.6.3 Passenger and Market Characteristics

A research study shows that 82% of South Korean passengers make a purchase in one or more duty free shops. ICN competes with several large department stores in Seoul that can sell merchandise duty and tax free for pickup at the airport without charge. The airport has about a 50% market share of total duty free sales.

### 14.6.4 Estimated Sales and Revenue

Estimated sales and revenue are estimated to be \$945 million in duty free, \$80 million in retail, and \$70 million in food and beverage. Estimated sales per enplaned passenger are \$68 in duty free, \$5 to \$6 in food and beverage, and \$5 to \$6 in other retail.

### 14.6.5 Concessions

There are 70 food and beverage outlets, including Bennigan's, Burger King, KFC, Subway, Bohemian Kitchen, Dunkin Donuts, Doughnut Plan NYC, Hoa Binh, McDonald's, Hotdog On, Shanghaideli, and Kraze Burger's. These outlets include a number of Korean restaurants as well: Bon Bibimbap, Jeontong Tukpegi, Biwon, Gayageum, Jayeon, and Mr. Kim among others. Specialty coffee includes Starbucks, Coffee Bean & Tea Leaf, Caribou, and Nescafe among others.

There are three duty free concessionaires—Schilla Duty Free, Lotte Duty Free, and the Korean National Tourism Organization. The three concessionaires operate category shops featuring the major categories (tobacco, liquor, perfumes and cosmetics, and electronics) as well as fashion boutiques including Bally, Cartier, MaxMara, Coach, Gucci, Celine, Bvlgari, Hermes, Fendi, Dior, Armani, Salvatore Ferragamo, Prada, Furla, MCM, and Chanel.

The specialty retail program is primarily in the landside area and includes The Face Shop, VOV, Missha, Skin Food, Etude House, Aritaum, The Olive Young, and GS Books.

Services include baby care lounges for children under 3 years of age and their guardians with nursing rooms, diaper-changing stations, reclining chairs, washstands, and water filters; an optician; laundry and dry cleaning; a medical center; pharmacies (airside and landside); a hair salon (Sergio Bossi); baggage storage; and mobile phone rental.

### 14.6.6 Terminal Configuration

The passenger terminal building includes 50 frontal gates and two concourses totaling 24 gates, which are used by Asiana and Korean Air. Ticketing areas are clustered by airline alliances, with Korean Air and Asiana occupying spaces near the center of the terminal. In 2008, a remote 28-gate satellite was opened that handles all other international airlines. Passengers reach Concourse B by an underground train, which is accessed at the center of the post-security side of the terminal building. The passenger flows through security to the train station expose passengers to a large cluster of luxury boutiques in the main terminal, plus a large concession program in the remote concourse. The terminal configuration is shown in Figure 14-15.

Concessions are located on multiple levels. In the public areas of the terminal building, Level 1B has space for concessions and services geared towards the employee market and visitors using the parking structure. Level 1F is the arrivals level and includes convenience retail and food and beverage and services including hotel counters, mobile phone rentals, and ground transportation. Level 3 is the public departures area and features an array of quick-serve food and specialty coffee units and some convenience and specialty retail.

All post-security concessions are on Level 3 or Level 4. The Level 4 landside area overlooks the ticketing area and includes an array of formal restaurants and bars and cafes, as well as observation spaces, a bookstore, and some quick-serve units. The post-security area on Level 3 has 66 duty free shops in 172,160 square feet of space.

Overall, the airport has more than 300,000 square feet of concession space spread over four levels, or about 20 square foot per 1,000 enplaning passengers. This space ratio is more than twice that of the average U.S. large hub airport terminal.

### 14.6.7 Commercial Strategy

Experience at SEL airport and the historically high duty free sales at major department stores demonstrated that there could be considerable demand for duty free and other concessions in the new airport. Existing demand combined with rapid growth of gross domestic product and dis-

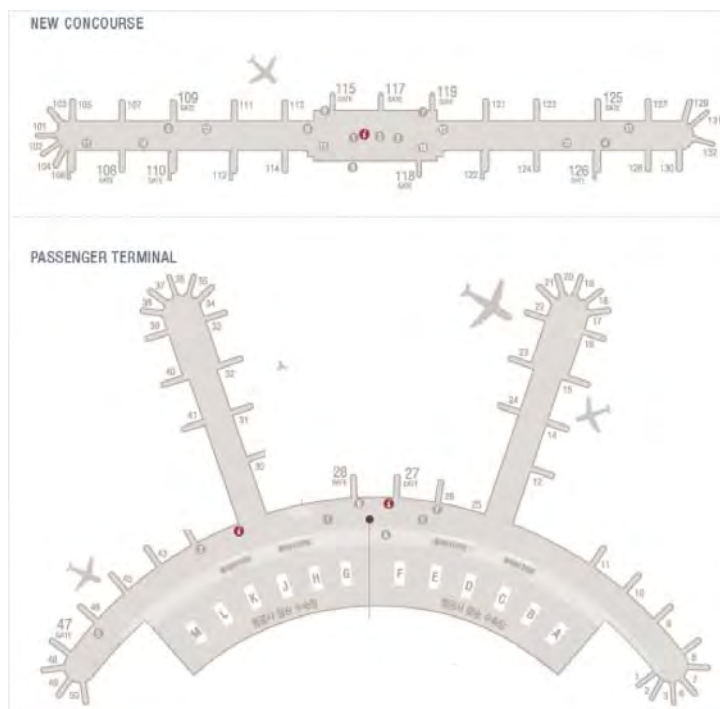

Source: [www.airport.kr](http://www.airport.kr) (As of October 12, 2010).

**Figure 14-15. Terminal layout (Seoul Incheon International Airport).**

possible income resulted in forecasts of high concession sales. Therefore, concession planning was an integral part of the planning of the new airport's terminal.

ICN has kept up with rapid passenger growth by developing capacity in advance of when it is needed and paying meticulous attention to the details of the passenger experience. The airport company has also added concession space where possible to keep up with demand. A future terminal expansion is planned that will bump out the terminal to create even larger concession areas in the post-security areas of the terminal.

The airport company has also developed the terminal complex to match airlines and passengers with concessions. Korean passengers and other international passengers have different buying and brand preferences. The two Korean carriers, Korean Air and Asiana, each use departure gates on one side of the main terminal, while foreign airlines use remote Concourse B. This allows for developing concessions that are geared towards the passenger mix in each area.

China is expected to become an increasingly important passenger segment. ICN has 20 routes to cities within China, and spending by Chinese nationals has been steadily increasing as both traffic and the middle class in China continues to grow.

#### 14.6.8 Unique Concessions and Innovations

When ICN remodeled and expanded its concessions, the airport company made a major effort to create a superior experience for connecting passengers, who are at the heart of IIAC's long-term strategic plan. Amenities for connecting passengers include the following:

- Internet lounges located on the mezzanine and post-security that include small cafes, wireless, and sponsored computer terminals. Fax, scanning, and business services are also available.

- An IT experience center sponsored by SK Telecom that provides high-speed access and includes displays of current and future mobile information technology.
- Airstar Terrace, an area on the terminal mezzanine with views of the airfield and terminal apron. Designed to serve long-dwell-time connecting passengers, the Airstar Terrace includes a book café offering coffee and newsstand items, a free Internet lounge, a juice bar, and a design gallery featuring local artists.
- The “Spa on Air” sauna, which offers hotel-quality facilities and service and the country’s first “tub-in-tub” (one bathtub inside another), as well as Thai-style massages. The spa also has meeting rooms, sleeping rooms, and a snack bar.
- The Cultural Museum of Korea operated by the National Museum of Korea and located in the airside Transfer Lounge. The museum houses Korean relics covering 5,000 years.

## 14.7 Copenhagen Airport

### 14.7.1 Ownership

Copenhagen Airport (CPH) is principally owned by MAp Airports (54%), formerly Macquarie Airports and now a separately listed company, and the Government of Denmark (39.2%). No other shareholder has more than a 5% stake.

### 14.7.2 Traffic Overview

In 2009, CPH handled 9.7 million enplaned passengers. The airport has a strong catchment area due to its location in Scandinavia. It is the principal airport serving the city of Copenhagen, which is the capital of Denmark, with a population of 1.8 million. CPH is also the dominant airport in Denmark, which has a population of 5.4 million.

The top 10 destinations and top 5 airlines for CPH are shown in Table 14-15.

CPH is a hub for SAS Airlines, a member of Star Alliance. SAS is partially owned by the Governments of Denmark, Norway, and Sweden. CPH is the busiest airport in the Nordic countries. Connecting passengers make up 26% of total passenger traffic. Low-cost airlines have a 14.5% market share. To attract this business, the airport has developed a terminal with limited amenities and reduced airline charges.

CPH was a strategic investor in and technical advisor to Mexico’s Southeast Group of airports and sold its stake in 2010.

**Table 14-15. Top 10 destinations and top 5 airlines (Copenhagen Airport).**

Top Destinations	Top 5 Airlines
1 London	1 SAS
2 Oslo	2 Norwegian
3 Stockholm	3 Cimber Sterling
4 Aalborg	4 EasyJet
5 Amsterdam	5 KLM
6 Paris	
7 Helsinki	
8 Frankfurt	
9 Zurich	
10 Brussels	



**Table 14-16. Reason for travel (Copenhagen Airport).**

	Male	Female	Total
Business	60%	40%	52%
Leisure	38%	58%	48%

### 14.7.3 Passenger and Market Characteristics

Passengers are 73% O&D and 27% transfer. Of the transfer passengers, 41% are from Sweden, 9% are domestic, and 36% are other international passengers. A breakdown of reasons for travel by gender is shown on Table 14-16.

More than half of all passengers are destined for European Union countries, followed by non-EU Europe excluding Sweden and Finland (Norway is not an EU member). Figure 14-16 shows passengers by destination. Figure 14-17 summarizes passengers by nationality.

### 14.7.4 Sales per Enplaning Passenger

CPH is privately held and does not disclose sales and revenue data. However, the duty free sales per enplaned passenger are estimated to be around \$10.00, with annual sales exceeding \$100 million.

### 14.7.5 Terminal Configuration

The airport recently consolidated its two main security checkpoints into a single central checkpoint and is in the process of adding 50,000 square feet of new concessions space. The new consolidated checkpoint feeds all passengers into a new, 28,000 square foot, walk-through duty free shop. An additional shopping area that includes restaurants, bars, and specialty retail is located at the exit of the walk-through duty free shop. The terminal layout allows for connections between concourses, with passengers flowing through the central terminal shopping area, which is lined with shops. The terminal configuration is shown in Figure 14-18.

CPH is looking to expand its low-cost airline services and expand passenger volumes. In 2010, CPH opened a terminal, CPH Go, serving low-cost airlines with airline terminal charges that are 35% less than the existing terminal concourses.

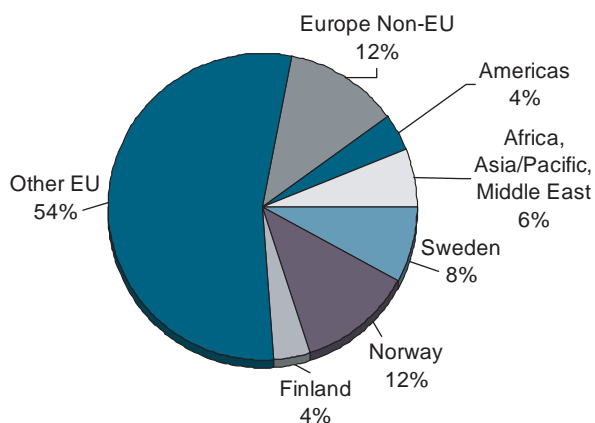

Source: Copenhagen Airports A/S 2010.

**Figure 14-16. Passengers by destination (Copenhagen Airport).**

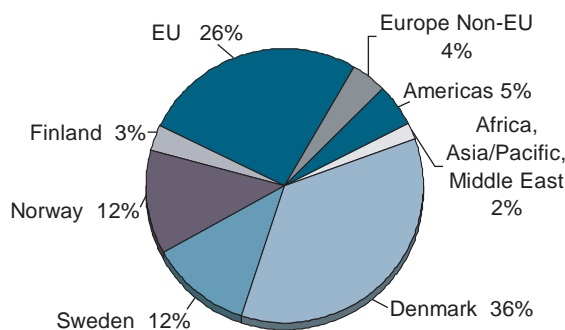

Source: Copenhagen Airports A/S 2010.

**Figure 14-17. Passengers by nationality (Copenhagen Airport).**

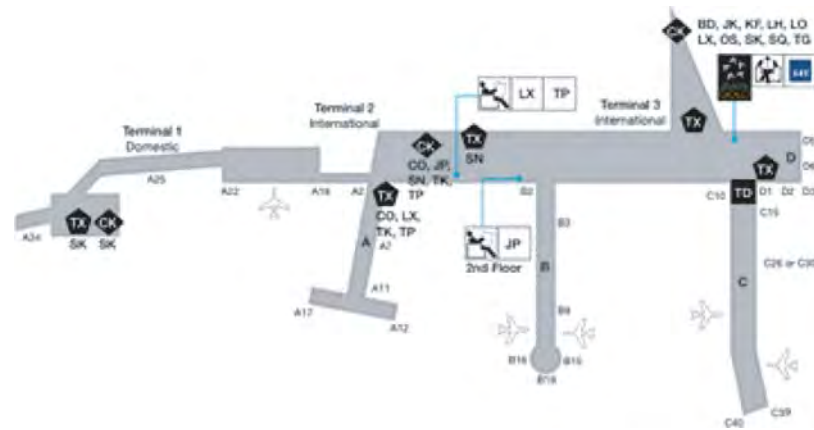

Source: CPH.dk (As of October 12, 2010).

**Figure 14-18. Terminal layout (Copenhagen Airport).**

### 14.7.6 Commercial Strategy

CPH is well positioned in terms of facilities, location, and airline service to act as a hub for much of Scandinavia. The high VAT rates and duties on luxury goods provide a strong opportunity for the airport and its duty free and tax free shops for passengers embarking on international flights. VAT rates in Denmark are 25% (meaning VAT comprises 20% of the cost of most items). Other countries in the region have similar high tax rates.

The airport company has developed a shopping street reminiscent of the Strøget, the city's famous pedestrian shopping street. Denmark is known for Scandinavian design, and the airport shops include well-known Danish designers including Georg Jensen and Royal Copenhagen.

The airport recently opened a tax free arrivals shop where passengers can buy a range of perfume, cosmetics, chocolate, beer, and wine at the same price as in the departure shops. The airport and the duty free operator absorb the taxes to make this offer attractive. The arrivals shop is also promoted as reducing passengers' carbon footprint, as the passenger does not have to take the added weight on his or her trip.

### 14.7.7 Concessions

There are 10 duty and tax free shops, 71 specialty shops, and 17 restaurants and bars, with a total of 106,000 square feet (10.7 square feet per 1,000 enplaned passengers). The airport is developing a new consolidated security checkpoint that will feed a 17,000 square foot, flow-through duty free shop, which will exit into the current terminal concession mall. A total of 50,000 square feet of space is planned or in development. After expansion, the airport will have 15.8 square feet per 1,000 enplaned passengers at current traffic levels.

Food and operators are SSP and HMS Host. Concepts include Baresso Coffee, Burger King, Caffé Ritazza, Ciao, Eyecon Restaurant and Bar, Joe & The Juice, Kitchen & Co., Kobenhavn, McDonalds, and Starbucks.

The duty free operator is Geber Heinemann. Other retailers include Georg Jensen, Royal Copenhagen, Aigner, AK Kaufmann, Bvlgari, Burberry, Caviar House, Ecco, Gant, Gucci, Hermes, Hugo Boss, Ilhums Bolighus, Lego, Lisbeth Dahl, Montblanc, Porsche Design, Ralph Lauren, Sand, Tie Rack, Tumi, Versace, and WHSmith.

Services include an in-terminal Hilton Hotel, meeting facilities, banks, travel agency, pay passenger lounges, children's play area, and currency exchange.

#### **14.7.8 Unique Concessions and Innovations**

Some of CPH's unique concessions and innovations are the following:

- Duty free shopping at least 24 hours in advance of flight. Merchandise is then ready for pick up at counters in one of the five duty free shops
- A Tax-Free Club offering regular discounts on merchandise
- Price guarantee to beat department stores by 20%
- A women-only cocktail lounge, planned as a refuge for single women business travelers
- An iPhone app showing arrivals, departures, shops and restaurants, and special promotions

---

---



---

# Glossary

**ACDBE.** Airport Concessions Disadvantaged Business Enterprise as defined in 49 CFR Part 23.

**Airside.** With respect to concessions, the post-security area of a terminal that is beyond the security checkpoint. Otherwise, the areas at the airport beyond security including terminal aprons and airfield.

**ARN.** Airport Revenue News.

**Bar/lounge.** Concession primarily offering alcoholic and non-alcoholic beverages with a limited food menu.

**Café.** Limited-service restaurant offering light meals, coffee, and other alcoholic and nonalcoholic beverages covering all parts of the day.

**CAM Fees.** Common-area maintenance fees paid to the airport or to another concessionaire as reimbursement for the maintenance of common (shared) areas, such as food courts.

**Casual dining restaurant with bar.** Restaurant offering hot meals and full bar service, usually with table service and wait staff. Can also apply to a restaurant with limited table service, where orders are placed at a counter and food is delivered to the table.

**CATS reports.** FAA Compliance Activity Tracking System reports filed by all U.S. airports each year.

**Connecting passenger.** Passenger who arrives on one flight and continues his or her trip on another flight without leaving the terminal.

**Convenience retail.** Traditional airport retail concepts providing traditional airport merchandise such as reading matter, candy and mints, snacks, and health and beauty aids. Convenience retail includes newsstands, news/gift shops, and newer hybrid retail concessions such as news/bookstores, news/coffee shops, and travel marts.

**Direct leasing.** Concession management approach where the airport leases out concession space to multiple concessionaires.

**Duty free.** Retail shops offering merchandise that is free of import duties, excise taxes, and local and state sales taxes. By law, sales are limited to departing international passengers.

**Dwell time.** Average time in minutes that a passenger spends in the terminal building or part of the terminal building. For example, one airport terminal had an average dwell time of 90 minutes, including 20 minutes in the pre-security area and 70 minutes in the post-security area.

**Effective rent.** Average percentage rent, calculated by dividing revenue (paid to the airport) by sales (earned by the concessionaire) for a period.

**FAA.** Federal Aviation Administration, an agency of the U.S. Department of Transportation.

**Focus group.** A small number of people brought together with a moderator to discuss a specific issue, product, or topic.

**Good faith efforts.** Efforts to achieve an ACDBE goal or other requirement of 49 CFR Part 23 that, by their scope, intensity, and appropriateness to the objective, can reasonably be expected to meet the program requirement.

**In-terminal advertising.** Display advertising within the terminal building using a variety of media, including banners, wall posters, back-lighted wall displays or dioramas, wall wraps, product displays, and digital screens. Also includes non-traditional advertising such as sponsorships, advertising on loading bridge exteriors, in-holdroom televisions, in-terminal radio stations, and Wi-Fi access portals.

**Labor peace.** Concession agreement provisions typically requiring proposers to reach prior agreement with relevant labor organizations so that, if selected, there will be no interruption of service during the term of the agreement.

**Landside.** Pre-security areas of the terminal building that are accessible by the general public without passing through security inspection.

**Leasing manager.** Third-party contractor paid a fee by the airport to market, select, and negotiate with concession tenants for the airport. Fee managers do not operate any concession spaces and, unlike developers, do not make capital investment in the terminal building.

**LEED.** Leadership in Energy and Environmental Design, a set of environmental building certification standards.

**Living wage.** A wage rate set by some cities and counties that is higher than the federal or state minimum wage and is intended to approximate the actual minimum cost of living in a jurisdiction. Where enacted by an airport sponsor, living wage rates will apply to concessionaires and others that do business with the airport.

**Local brand.** A local business with a recognized name and a favorable reputation in the local community.

**MAG or minimum annual guarantee.** Minimum yearly amount of rent to be paid to the airport by a concessionaire or, in some cases, a developer.

**Market segmentation.** Process of defining and subdividing a large homogeneous market into clearly identifiable segments having similar needs, wants, or demand characteristics.

**Master concessionaire.** Single concessionaire operating all of the concession space in a category or all of the space in multiple categories.

**Meeters and greeters.** Individuals who go to the airport to meet and greet arriving passengers.

**MMG or minimum monthly guarantee.** Minimum amount of rent to be paid by a concessionaire to the airport each month.

**National brand.** Business that operates a business in most parts of the United States and has established a favorable reputation.

**O&D passenger.** Origin and destination passenger, one who either begins or ends his or her trip at the airport. Differs from a connecting passenger.

**Part 23.** 49 Code of Federal Regulations Part 23, pertaining to airport concession disadvantaged business enterprises.

**Prime concessionaire.** A single firm operating approximately one-half or more of the concession space in a category of concession, such as food and beverage or retail. There are usually no more than two prime concessionaires operating in a single category.

**Productivity factor.** Standard measure used to determine supportable concession space at an airport. It is typically measured as the sales per square foot for each concession category that will provide a minimum but reasonable return for both the airport and the concessionaire.

**Quick-serve.** Food served over the counter, often made to order. Includes fast food, most food court units, grab-and-go, and most other self-service concession units.

**Regional brand.** Business that operates units in a defined region around the airport.

**Revenue.** As used in this resource manual, the amounts paid by concessionaires to the airport. (The term “sales” refers to the gross income of the concessionaires.)

**RFP or request for proposals.** Competitive solicitation approach whereby criteria are established and proposals are evaluated against the criteria, with the proposal receiving the highest score declared the winner.

**RMU or retail merchandise unit.** Small, self-contained retail merchandise unit such as a cart or kiosk.

**Sales.** Gross income of the concessionaire.

**Sales per enplaned passenger.** Average amount spent by one departing (enplaning) passenger. Also referred to as passenger spend rate (PSR).

**SBA.** Small Business Administration, an independent agency of the U.S. federal government.

**Sense of place.** Intrinsic characteristics that communicate an airport’s distinctiveness and location. Theming of an airport’s concession program contributes to the creation of a sense of place.

**SOQ or statement of qualifications.** Solicitation process whereby firms must provide evidence of a certain level of qualification in order to be able to participate in a subsequent solicitation process.

**Space per 1,000 enplanements.** Standard metric used to plan and evaluate the amount of space allocated to a concession program.

**Specialty coffee.** Concession unit featuring premium coffee and espresso-based drinks and may generally sell teas, juices, pastries, and prepackaged salads and sandwiches, depending on the terms of the concession agreement.

**Specialty entertainment.** In-terminal entertainment services such as virtual reality, simulators, game rooms, casinos, mini-golf, and indoor driving ranges and other diversions.

**Specialty retail.** A retail shop offering a specialized line of merchandise such as jewelry, leather goods, personal care products, children’s clothing, toys, candy/chocolates, or other merchandise. Excludes the convenience retail category.

**Spend rate.** Average amount spent by a departing passenger; the standard metric used to compare sales at different airports, different terminals, different locations within terminals, and different concessionaires.

**Street pricing.** When set by the airport, a policy requiring concessionaires to price goods and services at levels no greater than the prices for similar goods and services outside the airport. When set by a concessionaire or a developer, a strategy for encouraging sales.



**Supportable concession space.** Theoretical maximum amount of concession space in an airport that can be commercially supported and that is commercially viable for concession tenants.

**Third-party developer.** Company that subleases most or all of the concession space at an airport and, in turn, subleases to concessionaires on behalf of the airport. Revenue is shared between the Third-Party Developer and the airport operator.

**TSA.** Transportation Security Administration, an agency of the U.S. Government responsible for airport security inspection.

**U.S. DOT.** United States Department of Transportation.

**Well-wishers.** Individuals who accompany originating departing passengers into the terminal to see them off.

**Worker retention.** Program, policy, or requirement to consider hiring the employees of the outgoing concessionaire. Worker retention programs can range from voluntary efforts such as job fairs, to mandatory contractual requirements.

---

---

## References

- Air Transport Association of America (ATA). 2011. *Annual Results: U.S. Airlines* (table). Washington, DC. [www.airlines.org/Economics/DataAnalysis/Pages/AnnualResultsUSAirlines.aspx](http://www.airlines.org/Economics/DataAnalysis/Pages/AnnualResultsUSAirlines.aspx). Accessed April 6, 2011.
- Airport Revenue News. 2009. *Airport Revenue News Fact Book 2009*. Palm Beach Gardens, FL: Armbrust Aviation Group.
- Airports Council International. 2010. *ACI World Airport Service Quality Awards 2009* (Media Release). Geneva, Switzerland.
- Airports Council International-North America Airport Sustainability Committee. 2010. *Airport Sustainability: A Holistic Approach to Effective Airport Management*. Airports Council International-North America, November. [www.aci-na.org/static/entransit/Sustainability%20and%20LEED.pdf](http://www.aci-na.org/static/entransit/Sustainability%20and%20LEED.pdf).
- Amsterdam Airport Schiphol. 2010. *Traffic Review 2009*. February.
- Atkin, P., A. Hershkowitz, and D. Hoover. 2006. *Trash Landings—How Airlines and Airports Can Clean Up Their Recycling Programs*. New York: National Resources Defense Council.
- Atsmon, Y., B. Salsberg, and H. Yamanashi. 2009. *Luxury Goods in Japan: Momentary Sigh or Long Sayonara?* McKinsey Asia Consumer and Retail Practice, McKinsey & Company.
- Baskas, H. (2010). "Award-Winning Domestic Airports." *Stuck at the Airport* (blog). September 23. <http://stuckattheairport.com/2010/09/23/award-winning-domestic-airports/>. Accessed November 2010.
- Biggs, D. C., M. A. Bol, J. Baker, G. D. Gosling, J. D. Franz, and J. P. Cripwell. 2009. *ACRP Report 26: Guidebook for Conducting Airport User Surveys*. Washington, DC: Transportation Research Board of the National Academies.
- Copenhagen Airports A/S. 2010. *CPH Group Annual Report 2009*. Kastrup, Denmark.
- Duty Free News International. 2011. *The Duty Free and Travel Retail Database and Directory 2010/2011*. Croydon, UK: Metropolis Business Media.
- FAA Forecast and Performance Analysis Division. 2010. *Terminal Area Forecast Summary: Fiscal Years 2010–2030*. Washington, DC: Office of Aviation Policy and Plans, FAA.
- FAA. n.d. *Compliance Activity Tracking System (CATS), Report 127*. Washington, DC. <http://cats.airports.faa.gov/>. Accessed December 4, 2010.
- Generation Research. 2010. "Luxury Goods on the Rebound" *Travel Retail Executive News Digest*, March 30. [www.trend-news.com/default.asp?newsid=7858](http://www.trend-news.com/default.asp?newsid=7858).
- Incheon International Airport Corporation. 2010. *2010 Annual Report*. Incheon, Republic of Korea. July.
- Jacobs Consultancy, Inc. 2008. *Performance Indicators for Airports in the United States—2008*. Burlingame, CA.
- OECD (Organisation for Economic Co-operation and Development), Centre for Tax Policy and Administration. n.d. *OECD Tax Database*. [www.oecd.org/ctp/taxdatabase](http://www.oecd.org/ctp/taxdatabase).
- Port of Portland. (2008). "A Delicious Program: Concessions at PDX." *Portside*, Summer 2008. Portland, OR. [www.portofportland.com/PDFPOP/Pub\\_Portside\\_Summer\\_08.pdf](http://www.portofportland.com/PDFPOP/Pub_Portside_Summer_08.pdf).
- San Francisco Airport Commission. 2009. "Merchandising Plan for Terminal 2." Terminal 3 Concessions Outreach Presentation. San Francisco, CA.
- Schiphol Group. 2010. *Facts & Figures 2009*. Schiphol, The Netherlands.
- Stewart, D. R. 2010. "Concession Sales Take Off at Tulsa International Airport." *Tulsa World*. August 14. [www.tulsaworld.com/business/article.aspx?subjectid=45&articleid=20100814\\_45\\_E1\\_Airlin906933](http://www.tulsaworld.com/business/article.aspx?subjectid=45&articleid=20100814_45_E1_Airlin906933).
- U.S. Census Bureau. (2010). "State & County Quickfacts." Washington, DC. <http://quickfacts.census.gov/qfd/index.html>.
- U.S. DOT, Office of Small and Disadvantaged Business Utilization. n.d. *Official Questions and Answers (Q&A's) DBE Program Regulation (49 CFR 26)*. Washington, DC. [www.osdbu.dot.gov/dbeprogram/dbeqna.cfm](http://www.osdbu.dot.gov/dbeprogram/dbeqna.cfm). Accessed November 2010.
- Vanden Oever, K. V., A. Gittens, S. Warner-Dooley, A. Zaslov, H. Tremont, T. Snipes, and S. Hoerter. (2011). *ACRP Report 33: Guidebook for Developing and Managing Airport Contracts*. Washington, DC: Transportation Research Board of the National Academies.

# Bibliography

- “49 CFR Part 23 Participation by Disadvantaged Business Enterprises in Airport Concessions: Final Rule and Proposed Rule.” *Federal Register*, Volume 70, Number 54 (March 22, 2005).
- “A Growing Concern.” *Duty-Free News International*, Volume 22, Issue 4 (April, 2008) pp. 32–35.
- “A Sense of Place for Play and Pay.” *Airports International*, Volume 39, Number 3 (April, 2006) pp. 28–29.
- “ACI-NA Concessions Benchmarking Survey: News Gift and . . .” <http://www.aci-na.org>
- “Airport Retail: Top-flight Shops.” *Marketing*, (September 28, 2005).
- “ARN’S Best Concessionaires and Awards Programs.” *Airport Revenue News*, Volume 6, Issue 66 (March, 2007) pp. 14–29.
- “Beyond the Backlit.” <http://www.aci-na.org> (as of November 12, 2008).
- “Boom Continues in South America.” *Duty-Free News International*, Volume 22, Issue 3 (March, 2008) pp. 49–52.
- “Brands Rally Behind WDF as Heathrow T5 Opening Nears.” *Duty-Free News International*, Volume 22, Issue 2 (February, 2008) p. 1.
- “Concession Delivery System.” <http://www.aci-na.org>
- “Consumers Still Wary of Airport Shopping.” (August 29, 2006) <http://www.cbc.ca/news/story/2006/08/29/airport-stores.html>.
- “Crafting Food Concession Agreements.” <http://www.aci-na.org>
- “Going Greener—Minimizing Airport Environmental Impacts.” *Airports Council International (ACI-NA)*, (April, 2009).
- “Going Green—Minimizing Aviation’s Environmental Footprint at Airports.” *Airports Council International—North America*, (2007).
- “Guest Attraction.” *Passenger Terminal World*, (September, 2006) pp. 61–62.
- “Japan by Numbers.” *Traveler Retailer International*, (May, 2008) pp. 6–11.
- “Local Restaurants Landing at Indianapolis Airport.” *Indianapolis Business Journal*, (June 9, 2008).
- “Minding the Retail Mix.” *Airports International*, Volume 39, Number 3 (April, 2006) pp. 26–27.
- “New Ideas in Retail: Innovation Key to Revenue Generation.” *Airport Business*, (July 8, 2008) [http://www.airport-business.com/print/Airport-Business-Magazine/New-Ideas-in-Retail/1\\$5980](http://www.airport-business.com/print/Airport-Business-Magazine/New-Ideas-in-Retail/1$5980).
- “Passenger Pleasures.” *ACI-NA Centerlines*, (Spring 2005) pp. 26–27.
- “Phoenix Facelift.” *ACI-NA Centerlines*, (Fall, 2006).
- “Prominent Brand Names Embellish ATL’s Concourse E.” *Airport Revenue News*, Volume 4, Issue 42 (February, 2005) pp. 8–10.
- “Right Brand, Right Place.” *Airports International*, Volume 41, Number 3 (April, 2008) pp. 38–39.
- “Self-Service Concessions.” *ACI-NA Centerlines*, (Winter, 2006).
- “Toy Stories.” *Duty-Free News International*, Volume 22, Issue 4 (April, 2008) pp. 29–30.
- “Upgrades at PHX, BWI: Two Airports, Opposite Sides of the Country, with Two Approaches.” *Airport Business*, (July 8, 2008) [http://www.airportbusiness.com/print/Airport-Business-Magazine/Upgrades-at-PHX—BWI/1\\$3347](http://www.airportbusiness.com/print/Airport-Business-Magazine/Upgrades-at-PHX—BWI/1$3347).
- Abrams, Wendy, “Selling Point.” *Passenger Terminal World*, (November, 2006) p. 60.
- Airport Retail News*, “ARN Fact Book 2009”
- Airports Council International, “*Airport Benchmarking to Maximise Efficiency*”. (July 2006).
- Airports Council International, “Food Trends and Consumer Demands.” <http://www.aci-na.org> (as of November 6, 2007).
- Andrews, Theresa, “Nobody Does it Better.” *Airport World*, Volume 11, Issue 6 (December, 2006–January, 2007) pp. 32–34.
- Armbrust, Pauline, “BWI Showcases a Sleek New Concourse.” *Airport Revenue News*, Volume 4, Issue 50 (October, 2005) pp. 6–8.

- Armbrust, Pauline, "Involuntary Simplicity." *Airport Revenue News*, Volume 7, Issue 95 (August, 2009) pp. 42–43.
- Armbrust, Pauline, "The Fab Lab That's Portland International." *Airport Revenue News*, Volume 4, Issue 51 (November, 2005) pp. 34–37.
- Armbrust, Pauline, "Trends . . . Edward Cotton, partner, Butler, Shine, Stern and Partners (BSSP)." *Airport Revenue News*, Volume 5, Issue 52 (December, 2005/January, 2006) pp. 88–90.
- Armbrust, Pauline., "Celebrating 30 Years." *Airport Revenue News*, Volume 7, Issue 93 (June, 2009) pp. 28–31.
- Armbrust, Pauline., "Energy Fresh Ideas Dominated AMAC/FAA Conference." *Airport Revenue News*, Volume 5, Issue 58 (July, 2006) pp. 42–45.
- Arnoult, Sandra, "Hues of Blue at JFK." *Airport Equipment and Technology*, (March, 2006) p. 15.
- Atsmon, Y., Salsberg, B., and Yamanashi, H., "Luxury goods in Japan: Momentary sigh or long sayonara?" McKinsey Asia Consumer and Retail. (May, 2009) p. 11.
- Austin, Jane, "Café Culture." *Airport World*, Volume 11, Issue 4 (August–September, 2006) pp. 42–44.
- Bates, Joe, "A Missed Opportunity?" *Duty-Free News International*, Volume 22, Issue 9 (September, 2008) pp. 26–29.
- Bates, Joe, "Has Premiumisation Run Its Course in Asia?" *Duty-Free News International*, Volume 23, Issue 5 (May, 2009) pp. 66–68.
- Bates, Joe, "Let the Good Times Roll." *Duty-Free News International*, Volume 22, Issue 5 (May, 2008) pp. 94–95.
- Bates, Joe, "Liquor LAGs Behind at Toronto Pearson." *Travel Retailer International*, (April, 2008) p. 25.
- Bates, Joe, "Liquor Makeover Fuels Strong Growth at Istanbul." *Duty-Free News International*, Volume 22, Issue 2 (February, 2008) pp. 35–36.
- Bates, Joe, "Never Ending Story." *Airport World*, Volume 11, Issue 6 (December, 2006–January, 2007) pp. 22–23.
- Bates, Joe, "Staying Power." *Duty-Free News International*, Volume 23, Issue 2 (February, 2009) pp. 32–34.
- Benham, Doug, "Concession Programs Around the World." *ACI-NA Airport Concession Conference, Chicago*, (November, 2007) <http://www.aci-na.org>.
- Bent, Dan, "Centralized Distribution Systems." *2007 ACI-NA Concession Conference, Chicago*, (November, 2007) <http://www.aci-na.org>.
- Benton, Darryl, "Trends in Retail—What's New with Airport Concessions." *Embry-Riddle Aeronautical University and ACI-NA Concessions Conference*, (November 1, 2006) <http://www.aci-na.org>.
- Boudreau, Bruce, "Wild Economic Ride." *Airport Revenue News*, Volume 7, Issue 94 (July, 2009) pp. 36–37.
- Brady, Jennifer, "Recycling in Airports." <http://www.aci-na.org>, (as of November 6, 2007).
- Castanheiro, P., "Liz Claibourne Canada." <http://www.aci-na.org>, (as of November 12, 2008).
- Chia, Yvonne, "Schipol Airport Opens All-In-One Services Facility." *Moodie Report*, (April 17, 2009).
- Clark, Oliver, "All that Jazz." *Airport World*, Volume 13, Issue 4 (August–September, 2008) p. 85.
- Coleman, Marlene, "An Airport's Sky High View of a Winning Proposal." *25th Annual Airport Minority Advisory Council Conference*, (June, 2009) [www.amac-org.com](http://www.amac-org.com).
- Copenhagen Airports, "Annual Report 2009" pp 25–29, 48.
- Cugasi, John, "Extracting the Greatest Value From Your Contracts." *Airport Revenue News Conference and Exhibition*, (February 15, 2009).
- Davies, Gary, "Designing Concessions to Support Sales Growth." *Embry-Riddle Aeronautical University and ACI-NA Concessions Conference*, (November 1, 2006) <http://www.aci-na.org>.
- Dolby, Nigel, "Optimize Commercial Facilities." *Airport Revenue News*, Volume 7, Issue 92 (May, 2009) pp. 44–45.
- Dowling, Peter, "Auckland Airport Puts Final Touches to Dual-Retailer Model; Aims for "World-Class" Offer." *Moodie Report*, (April 9, 2009).
- Eaton, Michael, "A Vision of the Future." *Duty-Free News International*, Volume 23, Issue 1 (January, 2009) p. 42.
- Eaton, Michael, "Changing Consumer Tastes Prompt Premium Push in 2008." *Duty-Free News International*, Volume 22, Issue 1 (January, 2008) pp. 33–36.
- Establishing a Business Development Program (49 CFR Part 26, §26.35)
- Faithfull, Mark, "Retail Key for Heathrow's T-5." *Airport Revenue News*, Volume 6, Issue 80 (May, 2008) pp. 58–61.
- Feingold, Jean, "Building Non-Aeronautical Revenue." *ACI-NA Centerlines*, (June, 2008) pp. 18–20; 30.
- Folley, Patrick, "Buying Into Retail." *Airport World*, Volume 10, Issue 2 (May–April, 2005) pp. 49–50.
- Forgrieve, Janet, "Frequent Flier Favorites." *Airport Revenue News*, Volume 7, Issue 90 (March, 2009) pp. 22–25.
- Generations Research, "Luxury Goods on the Rebound." *Travel Retail Executive News Digest*, (March 20, 2010).
- Gibbs, Evonn, "Celebration Benefits All at Tulsa International." *Airport Revenue News*, Volume 6, Issue 68 (May, 2007) pp. 6–11.
- Gibbs, Evonn, "For Concessionaires, Efficiency is the First and Last." *Airport Revenue News*, Volume 6, Issue 79 (April, 2008) pp. 50–53.
- Gibbs, Evonn, "JFK Sports a New Terminal." *Airport Revenue News*, Volume 6, Issue 73 (October, 2007) pp. 6–8.
- Gibbs, Evonn, "Rent-Based Contract Awards Upset Industry." *Airport Revenue News*, Volume 6, Issue 71 (August, 2007) pp. 12–17.

- Gibbs, Evonn, "Seamless: Logistics a Team Effort at Any Airport." *Airport Revenue News*, Volume 6, Issue 70 (July, 2007) pp. 20–25.
- Gibbs, Evonn, "Trends Show Fertile Ground Beneath Food and Beverage Growth." *Airport Revenue News*, Volume 4, Issue 47 (July, 2005) pp. 10–14.
- Gibbs, Evonn, "Up Close and Personal with Moreton Binn, Owner of ExpressSpa." *Airport Revenue News*, Volume 4, Issue 40/41 (December, 2004–January, 2005) pp. 54–57.
- Gibbs, Evonn, "Vino Volo Flies Without Attitude." *Airport Revenue News*, Volume 6, Issue 65 (February, 2007) pp. 82–85.
- Gibbs, Evonn, "Whether Grabbing or Dining, PAX Want Quality." *Airport Revenue News*, Volume 4, Issue 47 (July, 2005) pp. 20–23.
- Gibbs, Evonn., "DBEs in the Spotlight." *Airport Revenue News*, Volume 4, Issue 46 (June, 2005) pp. 16–19.
- Gibbs, Evonn., "More to DBE Success than Percentages." *Airport Revenue News*, Volume 4, Issue 46 (June, 2005) pp. 10–14.
- Gibbs, Evonn., "Seeking Uniformity: ACDBEs Want Certification Loopholes Closed." *Airport Revenue News*, Volume 6, Issue 81 (June, 2008) pp. 22–27.
- Gibbs, Evonn., "Training, Reciprocity Dominate AMAC Focus." *Airport Revenue News*, Volume 6, Issue 81 (June, 2008) pp. 28–31.
- Gill, Robbie, "Retail Therapy." *Passenger Terminal World*, (March, 2006) pp. 74–78.
- Goldberg, Eddy, "Brand Essence: World's Largest Multi-Concept Operator Plays Well with Others." *Multi-Unit Franchising Magazine*, Issue II, 2008 (August 7, 2008).
- Graf, Tyler, "Food Retailers at Portland International Space Hungry for Space at PDX." *Portland Daily Journal of Commerce* (October 4, 2007).
- Greenberg Traurig LLP, "Risks of Going Green." *Presentation to Pegasus Corp.*, (January, 2008) <http://www.aci-na.org>
- Grossman, David, "Airport Food Good Enough to Take Home?" [www.usatoday.com](http://www.usatoday.com) (as of March 4, 2008).
- Hickson, Kevin, "The Evolution of Airport Retail." *Airports International*, Volume 41, Number 7 (October, 2008) pp. 38–39.
- Holbrook, Doug, "Green and Organic Business Solutions." *ACI-NA Annual Conference, Seattle, Washington*, (November 1, 2006) <http://www.aci-na.org>
- Holden, Janice, "The Shops at Terminal 4." *Airports International*, Volume 40, Number 2 (March, 2007) pp. 36–37.
- Hooper, William, "Meshing Great Concession Programs with Great Terminal Design." *Embry-Riddle Aeronautical University and ACI-NA Concessions Conference*, <http://www.aci-na.org> (as of November 1, 2006).
- <http://aaae.org> (As of December 13, 2010).
- <http://aconline.org> (As of December 13, 2010).
- <http://aci-na.org> (As of December 13, 2010).
- <http://agc-oregon.org> (As of December 13, 2010).
- <http://amac-org.com> (As of December 13, 2010).
- <http://nmsdc.org> (As of December 13, 2010).
- <http://portofportland.com> (As of December 13, 2010).
- <http://wbenc.org> (As of December 13, 2010).
- <http://westfield.com/corporate/property-portfolio/united-states/airport-retail/>
- [http://www.aci-na.org/committees/comm\\_resourcecenter](http://www.aci-na.org/committees/comm_resourcecenter) (As of November 2010).
- <http://www.baa.com> (as of October 5, 2010)
- <http://www.portofportland.com> (as of December 5, 2010)
- <http://www.schiphol.nl/> (as of October 10, 2010).
- Huff, Agnes, "Delivering What Customers Demand Now." *Airport Business*, [www.airportbusiness.com](http://www.airportbusiness.com) (as of February, 2009).
- Ibrahim, Ibrahim, "Why Brand?" *Passenger Terminal World*, (November, 2006) pp. 46–50.
- Incheon International Airport Corporation, "Annual Report 2009" pp 24–43.
- Jacobs Consultancy Inc., "Jeddah King Abdul Aziz International Airport, Hajj Terminal Advertising Master Plan", August 2007, Ottawa Canada, 38 pages
- Jacobs Consultancy Inc., "LAX Bradley West Waste Management and Retail Program Support Logistics", 2009, Burlingame, California, 18 pages
- Jacobs Consultancy Inc., "Montreal-Trudeau International Airport Retail Plan Update", April 2008, Montreal, Canada, 84 pages
- Jacobs Consultancy Inc., "Quebec Jean-Lesage International Airport Retail Plan", April 2006, Montreal, Canada, 184 pages
- Jacobs Consultancy Inc., "Renovation and modernization of the terminal building, Santo Domingo Las Americas International Airport, Concessions Planning", December 2009, Ottawa Canada, 86 pages
- Kettle, Jane, "Hold the Mayo." *Airport World*, Volume 10, Issue 4 (August–September, 2005) pp. 26–28.



- Knight, Mark, "BAA USA: Retail Space Optimization." <http://www.aci-na.org>
- Leland, Karen and Bailey, Keith, "Watercooler Wisdom: Creating a Customer Focused Company Through Service Training." *Airport Revenue News*, Volume 4, Issue 47 (July, 2005) pp. 46–47.
- Lemson, Marion, "Food for Flyers." *Passenger Terminal World*, (June, 2008) pp. 77–78.
- Levine, Michael, "Airport Restaurants: Dining Today and Tomorrow." <http://www.aci-na.org>
- Lewis, Len, "Inventory Traffic Control Plan Takes Off." *Stores*, (February, 2008).
- Lightfoot, Lori, "Facilitating Success." *Airport Revenue News*, Volume 7, Issue 93 (June, 2009) pp. 46–49.
- Lindsay, Greg, "Airport Retail Takes Off." *Footware News*, (July 24, 2006).
- Lipsith, Gavin, "SSP Rethinks the Consumer." *Duty-Free News International*, Volume 22, Issue 6 (June, 2008) p. 12.
- Lloyd-Jones, Trevor, "A Long Road: Retail Brands Establish Presence in European Airports." *Airport Revenue News*, Volume 4, Issue 48 (August, 2005) pp. 24–25.
- Lloyd-Jones, Trevor, "Airports Fill Need in the Mobile World." *Airport Revenue News*, Volume 5, Issue 52 (December, 2005/January, 2006) pp. 68–70.
- Lloyd-Jones, Trevor, "Reform of Concessions Contracts: Vision Rather Than a Tool Kit." *Airport Revenue News*, Volume 4, Issue 42 (February, 2005) pp. 66–69.
- Lowden, Ian, "In the Money." *Airport World*, Volume 12, Issue 3 (June–July, 2007) p. 31.
- Lumley, Bill, "Breakthrough as US Gains on EU Recognition on Liquids." *Duty-Free News International*, Volume 23, Issue 1 (January, 2009) p. 1.
- Lumley, Bill, "Making a Connection." *Duty-Free News International*, Volume 23, Issue 4 (April, 2009) pp. 36–40.
- Lumley, Bill, "The Changing Face of Air Travel." *Duty-Free News International*, Volume 23, Issue 5 (May, 2009) p. 60.
- Martel, Francois, "External factors and their impact on non-aeronautical revenue", Henry Stewart Publications 1750-1938, Journal of Airport Management Vol. 3, NO. 4, July–September 2009, pp. 337–344
- Martel, Francois, Presentation: "External trends and their impact on non-aeronautical revenue", International Quality & Productivity Center (IQPC), Maximising non-Aeronautical Revenue through Airport Services Conference, Singapore, August 26–27 2008
- Martel, Francois, Presentation: "Trends in Airport Concessions", 17th ALPHA-ACI Congress of Francophone Airports, Montreal Canada, October 17–21, 2007.
- Mastin, Kyle, "Concessions Expansion and Space Utilization Review." <http://www.aci-na.org> (as of November 11, 2008).
- Mentor Protégé Program Guidelines (Appendix D of 49 CFR Part 26)
- Messasalma, Nichole, "European Spenders." *Duty Free News International*, Volume 22, Issue 11 (October 15, 2008) pp. 111–112.
- Messasalma, Nicole, "Leading Brands and Exclusive Concepts Mark Changi T2 Opening." *Duty-Free News International*, Volume 22, Issue 1 (January, 2008) p. 5.
- Mezzasalma, Nichole, "Money Talks." *Duty-Free News International*, Volume 22, Issue 3 (March, 2008) pp. 54–56.
- Mezzasalma, Nichole, "Open-Sale Season." *Duty-Free News International*, Volume 22, Issue 7 (July, 2008) pp. 41–45.
- Mezzasalma, Nichole, "The Darkness Before the Dawn." *Duty-Free News International*, Volume 22, Issue 10 (October 1, 2008) pp. 28–29.
- Mezzasalma, Nichole, "Tourists to the Rescue?" *Duty-Free News International*, Volume 23, Issue 1 (January, 2009) p. 26.
- Mezzasalma, Nichole, "Watch this Space." *Duty-Free News International*, Volume 22, Issue 7 (July, 2008) pp. 46–48.
- Mezzasalma, Nicole, "Looking Back, Moving Forward." *Duty-Free News International*, Volume 23, Issue 6 (June, 2009) p. 41.
- Moodie, Martin, "Purchasing Power of Women Travelers: Huge and Growing." *Airport Revenue News*, Volume 6, Issue 70 (July, 2007) p. 56.
- Nashir, Cheryl, "San Francisco International Airport." <http://www.aci-na.org>
- Nelson, Nichole, "A Tale of Two Diversified Cities." *ACI-NA Centerlines*, (September, 2008) pp. 69–73.
- Newman, Sandra, "Dubai Duty Free Maintains Upward Momentum." *Duty-Free News International*, Volume 22, Issue 1 (January, 2008) p. 12.
- Newman, Sandra, "Weakening Dollar Drives US Tourism Boom." *Travel Retailer International*, (April, 2008) pp. 20–22.
- Nichol, Cindy, "ACRP Synthesis 1, Innovative Finance and Alternative Sources of Revenue for Airports, A Synthesis of Airport Practice." *Transportation Research Board*, (2007).
- Pentol, Andrew, "Checking In at JFK T5." *Duty-Free News International*, Volume 23, Issue 3 (March, 2009) pp. 23–24.
- Pentol, Andrew, "Korea Development." *Duty-Free News International*, Volume 22, Issue 10 (October 1, 2008) pp. 30–31.



- Pentol, Andrew, "Market Forces." *Duty-Free News International*, Volume 23, Issue 2 (February, 2009) pp. 20–21.
- Pentol, Andrew, "Softening the Blow." *Duty-Free News International*, Volume 23, Issue 5 (May, 2009) pp. 42–44.
- Peterson, Eric, "Retail Trends: Attention Airports: Changing Face of Airport Retail Deserves Attention." *Airport Business*, (July 8, 2008) [http://www.airportbusiness.com/print/Airport-Business-Magazine/Retail-Trends—Attention-airports—Changing-face-of-airport-retail-deserves-attention/1\\$1234](http://www.airportbusiness.com/print/Airport-Business-Magazine/Retail-Trends—Attention-airports—Changing-face-of-airport-retail-deserves-attention/1$1234).
- Pickering, Andrew, "Location, Location, Location." *Passenger Terminal World*, (September, 2008) pp. 54–55.
- Port of Portland, "Portside", Summer 2008.
- Rasmus, Ripley, et al., "'Green' Concession Practices and the Growing Popularity of Organic Products." <http://www.aci-na.org> (as of November 6, 2007).
- Reis, Mark, "Sustainability and the Bottom Line." *ACI-NA 16th Annual Conference*, (October 2, 2007).
- Richards, Jodi, "Retail Highlights: A Look at Trends, News in Airport Retail, Concessions." *Airport Business*, (September, 2006).
- Richards, Jodi, "Sensational Schiphol: More than an Airport—An Airport City." *Airport Business*, (March, 2005).
- Rozario, Kevin, "Absolutely Flawless." *Duty-Free News International*, Volume 22, Issue 6 (June, 2008) pp. 36–39.
- Rozario, Kevin, "American Beauty." *Duty-Free News International*, Volume 22, Issue 3 (March, 2008) pp. 79–80.
- Rozario, Kevin, "An Attraction to Fashion." *Duty-Free News International*, Volume 22, Issue 4 (April, 2008) pp. 44–47.
- Rozario, Kevin, "The Brands Business." *Airport World*, Volume 12, Issue 6 (December, 2007–January, 2008) pp. 41–46.
- Schiphol Group, "Facts and Figures 2009." (2009)
- Shepherd, Darren, "Build Additional Revenue and Services in Creative and Space-Conscious Ways." *Airport Revenue News*, Volume 6, Issue 71 (August, 2007) pp. 50–51.
- Stasiulevicus, Garry, "Ignorance is NOT Bliss." *Travel Retailer International*, (March, 2009) pp. 32–35.
- Stone, Robin, "Bottoms Up!" *Airport World*, Volume 13, Issue 6 (December, 2008–January, 2009) pp. 46–48.
- Sypher:Mueller International Inc., "Aer Rianta International Retail and Merchandising Plan, JFK International Airport Terminal 4, August 2003", Ottawa Canada, 90 pages
- Sypher:Mueller International Inc., "Barbados Grantley Adams International Airport, Retail Plan", 2002, Ottawa Canada 85 pages
- Sypher:Mueller International Inc., "Norman Y. Mineta San Jose International Airport Concessions Master Plan", October 2004, Escondido CA, 168 pages
- Tellijohn, Andrew, "Airports Reach Beyond DBE Programs to Embrace Diversity." *Airport Revenue News*, Volume 6, Issue 65 (February, 2007) pp. 22–28.
- Tellijohn, Andrew, "Art, Space and Light." *Airport Revenue News*, Volume 6, Issue 79 (April, 2008) pp. 8–10.
- Tellijohn, Andrew, "Building for the Future." *Airport Revenue News*, Volume 7, Issue 93 (June, 2009) pp. 8–11.
- Tellijohn, Andrew, "Catering to Kids." *Airport Revenue News*, Volume 6, Issue 74 (November, 2007) pp. 57–59.
- Tellijohn, Andrew, "DBE Challenges and Successes Going Forward Focus of AMAC Show." *Airport Revenue News*, Volume 6, Issue 71 (August, 2007) pp. 48–49.
- Tellijohn, Andrew, "DBE Nurturing Expands, Benefits Airports, Locals, Owners." *Airport Revenue News*, Volume 5, Issue 57 (June, 2006) pp. 28–31.
- Tellijohn, Andrew, "High End Hurting But Surviving." *Airport Revenue News*, Volume 7, Issue 94 (July, 2009) pp. 26–31.
- Tellijohn, Andrew, "Loving Locals." *Airport Revenue News*, Volume 7, Issue 94 (July, 2009) pp. 38–41.
- Tellijohn, Andrew, "Nailing the Luxury Market." *Airport Revenue News*, Volume 6, Issue 80 (May, 2008) pp. 56–57.
- Tellijohn, Andrew, "Seeking Guidance" *Airport Revenue News*, Volume 6, Issue 81 (June, 2008) pp. 42–47.
- Tellijohn, Andrew, "Small Steps Forward." *Airport Revenue News*, Volume 7, Issue 93 (June, 2009) pp. 16–21.
- Tellijohn, Andrew, "Spokane International's Friendlier Face Has National, Local Profile." *Airport Revenue News*, Volume 5, Issue 54 (March, 2006) pp. 8–10.
- Tellijohn, Andrew, "Techie Heaven." *Airport Revenue News*, Volume 7, Issue 95 (August, 2009) pp. 20–24.
- Tellijohn, Andrew, "Unfinished Business Keeps DBE Program on Edge." *Airport Revenue News*, Volume 5, Issue 57 (June, 2006) pp. 14–17.
- The Clean Airport Partnership, Inc., "Managing a Green Airport." (August, 2007).
- Transportation Research Board—Airport Cooperative Research Program. Report 25 "Airport Terminal Planning and Design." 2010.
- Twentyman, Jessica, "Top Shop." *Airport World*, Volume 12, Issue 3 (June–July, 2007) pp. 38–39.
- U.S. DOT Business Development Program Guidelines (Appendix C of 49 CFR Part 26)
- Vines, Mike, "Building on a Retail Revolution." *Airport Magazine*, (August/September, 2006) pp. 32–34; 51.
- Ward, Carol and Tellijohn, Andrew, "Perceptions Slow to Change." *Airport Revenue News*, Volume 6, Issue 66 (March, 2007) pp. 44–47.
- Ward, Carol, "Airports Recognize the Cogs in the Wheel of Financial Success." *Airport Revenue News*, Volume 6, Issue 68 (May, 2007) pp. 40–43.

- Ward, Carol, "Balancing Act." *Airport Revenue News*, Volume 6, Issue 80 (May, 2008) pp. 34–37.
- Ward, Carol, "Brand Exposure." *Airport Revenue News*, Volume 6, Issue 82 (July, 2008) pp. 18–21; 23.
- Ward, Carol, "Concession Bidders Scarce at Small Airports." *Airport Revenue News*, Volume 4, Issue 50 (October, 2005) pp. 24–27.
- Ward, Carol, "Concessionaire Winners Articulate Why They Won." *Airport Revenue News*, Volume 4, Issue 43 (March, 2005) pp. 28–31.
- Ward, Carol, "Connecting Passengers." *Airport Revenue News*, Volume 6, Issue 82 (July, 2008) pp. 40–43.
- Ward, Carol, "Embry Riddle Conference Brings Concessions Challenges, Achievements to Forefront." *Airport Revenue News*, Volume 5, Issue 52 (December, 2005/January, 2006) pp. 92–97.
- Ward, Carol, "Forward-Thinking Retail." *Airport Revenue News*, Volume 6, Issue 71 (August, 2007) pp. 26–31.
- Ward, Carol, "Making It Big in Small Airports." *Airport Revenue News*, Volume 6, Issue 65 (February, 2007) pp. 42–48.
- Ward, Carol, "Mix Matters: Concession Challenges for Small Airports." *Airport Revenue News*, Volume 5, Issue 56 (May, 2006) pp. 18–19.
- Ward, Carol, "Reaching for Revenues." *Airport Revenue News*, Volume 5, Issue 55 (April, 2006) pp. 12–15.
- Ward, Carol, "Tenacity Pays Off: Airports Keep Earning and Saving." *Airport Revenue News*, Volume 4, Issue 40/41 (December, 2004–January, 2005) pp. 18–20.
- Ward, Carol, "Turning Heads." *Airport Revenue News*, Volume 7, Issue 92 (May, 2009) pp. 16–19.
- Ward, Carol, "Wi-Fi Challenges." *Airport Revenue News*, Volume 5, Issue 62 (November, 2007) pp. 26–33.
- Ward, Carol, "A Matter of Control." *Airport Revenue News*, Volume 7, Issue 93 (June, 2009) pp. 38–43.
- Ward, Carol, "Finding Funds." *Airport Revenue News*, Volume 7, Issue 93 (June, 2009) pp. 22–25.
- Ward, Carol, "Gray Areas: DBE Rule Prompts Discussions, Efforts to Change It." *Airport Revenue News*, Volume 5, Issue 57 (June, 2006) pp. 12–13.
- Ward, Carol, "Interpreting New DBE Rule is Focus of AMAC Conference." *Airport Revenue News*, Volume 4, Issue 47 (July, 2005) pp. 42–45.
- Ward, Carol, "Quantifying Discrimination." *Airport Revenue News*, Volume 6, Issue 81 (June, 2008) pp. 38–41.
- West, Nancy K., "Disparity Studies ACDBE Participation in Airport Concessions." *ACI-NA Legal Committee*, (September 29, 2007).
- West, Nancy, "DBEs Must Challenge Status Quo." *Airport Revenue News*, Volume 5, Issue 75/76 (December, 2007–January, 2008) pp. 74–75.

*Abbreviations and acronyms used without definitions in TRB publications:*

AAAE	American Association of Airport Executives
AASHO	American Association of State Highway Officials
AASHTO	American Association of State Highway and Transportation Officials
ACI-NA	Airports Council International-North America
ACRP	Airport Cooperative Research Program
ADA	Americans with Disabilities Act
APTA	American Public Transportation Association
ASCE	American Society of Civil Engineers
ASME	American Society of Mechanical Engineers
ASTM	American Society for Testing and Materials
ATA	Air Transport Association
ATA	American Trucking Associations
CTAA	Community Transportation Association of America
CTBSSP	Commercial Truck and Bus Safety Synthesis Program
DHS	Department of Homeland Security
DOE	Department of Energy
EPA	Environmental Protection Agency
FAA	Federal Aviation Administration
FHWA	Federal Highway Administration
FMCSA	Federal Motor Carrier Safety Administration
FRA	Federal Railroad Administration
FTA	Federal Transit Administration
HMCRP	Hazardous Materials Cooperative Research Program
IEEE	Institute of Electrical and Electronics Engineers
ISTEA	Intermodal Surface Transportation Efficiency Act of 1991
ITE	Institute of Transportation Engineers
NASA	National Aeronautics and Space Administration
NASAO	National Association of State Aviation Officials
NCFRP	National Cooperative Freight Research Program
NCHRP	National Cooperative Highway Research Program
NHTSA	National Highway Traffic Safety Administration
NTSB	National Transportation Safety Board
PHMSA	Pipeline and Hazardous Materials Safety Administration
RITA	Research and Innovative Technology Administration
SAE	Society of Automotive Engineers
SAFETEA-LU	Safe, Accountable, Flexible, Efficient Transportation Equity Act: A Legacy for Users (2005)
TCRP	Transit Cooperative Research Program
TEA-21	Transportation Equity Act for the 21st Century (1998)
TRB	Transportation Research Board
TSA	Transportation Security Administration
U.S.DOT	United States Department of Transportation