

Progress Toward Restoring the Everglades: The Third Biennial Review - 2010

ISBN
978-0-309-16006-3

328 pages
6 x 9
PAPERBACK (2011)

Committee on Independent Scientific Review of Everglades Restoration Progress; National Research Council

 Add book to cart

 Find similar titles

 Share this PDF



Visit the National Academies Press online and register for...

- ✓ Instant access to free PDF downloads of titles from the
 - NATIONAL ACADEMY OF SCIENCES
 - NATIONAL ACADEMY OF ENGINEERING
 - INSTITUTE OF MEDICINE
 - NATIONAL RESEARCH COUNCIL
- ✓ 10% off print titles
- ✓ Custom notification of new releases in your field of interest
- ✓ Special offers and discounts

Distribution, posting, or copying of this PDF is strictly prohibited without written permission of the National Academies Press. Unless otherwise indicated, all materials in this PDF are copyrighted by the National Academy of Sciences. Request reprint permission for this book

PROGRESS TOWARD RESTORING THE EVERGLADES

The Third Biennial Review - 2010

Committee on Independent Scientific Review of Everglades Restoration Progress

Water Science and Technology Board

Board on Environmental Studies and Toxicology

Division on Earth and Life Studies

NATIONAL RESEARCH COUNCIL

OF THE NATIONAL ACADEMIES

THE NATIONAL ACADEMIES PRESS

Washington, D.C.

www.nap.edu

THE NATIONAL ACADEMIES PRESS 500 Fifth Street, N.W. Washington, D.C. 20001

NOTICE: The project that is the subject of this report was approved by the Governing Board of the National Research Council, whose members are drawn from the councils of the National Academy of Sciences, the National Academy of Engineering, and the Institute of Medicine. The members of the panel responsible for the report were chosen for their special competences and with regard for appropriate balance.

This report was produced under assistance of Cooperative Agreement No. W912EP-04-2-0001 with the Department of the Army. Support for this project was provided by the U.S. Department of the Interior and the South Florida Water Management District. Any opinions, findings, conclusions, or recommendations expressed in this publication are those of the author(s) and do not necessarily reflect the views of the organizations or agencies that provided support for the project.

International Standard Book Number-13: 978-0-309-16006-3

International Standard Book Number-10: 0-309-16006-5

Cover credit: Cover image courtesy of Patrick Lynch, South Florida Water Management District. Photo showing a submerged aquatic vegetation cell within STA-5, used to provide final treatment of water before it is discharged into Rotenberger Wildlife Management Area.

Additional copies of this report are available from the National Academies Press, 500 Fifth Street, N.W., Lockbox 285, Washington, DC 20055; (800) 624-6242 or (202) 334-3313 (in the Washington metropolitan area); Internet, <http://www.nap.edu>.

Copyright 2010 by the National Academy of Sciences. All rights reserved.

Printed in the United States of America

THE NATIONAL ACADEMIES

Advisers to the Nation on Science, Engineering, and Medicine

The **National Academy of Sciences** is a private, nonprofit, self-perpetuating society of distinguished scholars engaged in scientific and engineering research, dedicated to the furtherance of science and technology and to their use for the general welfare. Upon the authority of the charter granted to it by the Congress in 1863, the Academy has a mandate that requires it to advise the federal government on scientific and technical matters. Dr. Ralph J. Cicerone is president of the National Academy of Sciences.

The **National Academy of Engineering** was established in 1964, under the charter of the National Academy of Sciences, as a parallel organization of outstanding engineers. It is autonomous in its administration and in the selection of its members, sharing with the National Academy of Sciences the responsibility for advising the federal government. The National Academy of Engineering also sponsors engineering programs aimed at meeting national needs, encourages education and research, and recognizes the superior achievements of engineers. Dr. Charles M. Vest is president of the National Academy of Engineering.

The **Institute of Medicine** was established in 1970 by the National Academy of Sciences to secure the services of eminent members of appropriate professions in the examination of policy matters pertaining to the health of the public. The Institute acts under the responsibility given to the National Academy of Sciences by its congressional charter to be an adviser to the federal government and, upon its own initiative, to identify issues of medical care, research, and education. Dr. Harvey V. Fineberg is president of the Institute of Medicine.

The **National Research Council** was organized by the National Academy of Sciences in 1916 to associate the broad community of science and technology with the Academy's purposes of furthering knowledge and advising the federal government. Functioning in accordance with general policies determined by the Academy, the Council has become the principal operating agency of both the National Academy of Sciences and the National Academy of Engineering in providing services to the government, the public, and the scientific and engineering communities. The Council is administered jointly by both Academies and the Institute of Medicine. Dr. Ralph J. Cicerone and Dr. Charles M. Vest are chair and vice chair, respectively, of the National Research Council.

www.national-academies.org

**COMMITTEE ON INDEPENDENT SCIENTIFIC REVIEW OF
EVERGLADES RESTORATION PROGRESS¹**

FRANK W. DAVIS, *Chair*, University of California, Santa Barbara
STEVEN R. BEISSINGER, University of California, Berkeley
WILLIAM G. BOGGESS, Oregon State University, Corvallis
CHARLES T. DRISCOLL, Syracuse University, New York
JOAN G. EHRENFELD, Rutgers University, New Brunswick, New Jersey
WILLIAM L. GRAF, University of South Carolina, Columbia
WENDY D. GRAHAM, University of Florida, Gainesville
CHRIS T. HENDRICKSON, Carnegie Mellon University, Pittsburgh,
Pennsylvania
WILLIAM P. HORN, Birch, Horton, Bittner, and Cherot, Washington, D.C.
DAVID H. MOREAU, University of North Carolina, Chapel Hill
K. RAMESH REDDY, University of Florida, Gainesville
R. WAYNE SKAGGS, North Carolina State University, Raleigh
ROBERT R. TWILLEY, Louisiana State University, Baton Rouge

NRC Staff

STEPHANIE E. JOHNSON, Study Director, Water Science and Technology
Board
DAVID J. POLICANSKY, Scholar, Board on Environmental Studies and
Toxicology
MICHAEL J. STOEVER, Research Associate, Water Science and Technology
Board

¹The activities of this committee were overseen and supported by the National Research Council's Water Science and Technology Board and Board on Environmental Studies and Toxicology (see Appendix E for listing). Biographical information on committee members and staff is contained in Appendix F.

Acknowledgments

Many individuals assisted the committee and the National Research Council staff in their task to create this report. We would like to express our appreciation to the following people who have provided presentations to the committee and served as guides during the field trips:

Ken Ammon, South Florida Water Management District
Stu Appelbaum, U.S. Army Corps of Engineers
Nick Aumen, National Park Service
Carmela Bedregal, South Florida Water Management District
Laura Brandt, U.S. Fish and Wildlife Service
Eric Bush, U.S. Army Corps of Engineers
Eric Cline, South Florida Water Management District
Susan Connor, U.S. Army Corps of Engineers
Deborah Drum, South Florida Water Management District
Dennis Duke, U.S. Department of the Interior
Gretchen Ehlinger, U.S. Army Corps of Engineers
Robert Fennema, National Park Service
Carl Fitz, University of Florida
Lawrence Gerry, South Florida Water Management District
Patti Gorman, South Florida Water Management District
Andy Gottlieb, South Florida Water Management District
Susan Gray, South Florida Water Management District
Scot Hagerthy, South Florida Water Management District
Matt Harwell, U.S. Fish and Wildlife Service
Lorraine Heisler, U.S. Fish and Wildlife Service
Todd Hopkins, U.S. Fish and Wildlife Service
Delia Ivanoff, South Florida Water Management District
Robert Johnson, National Park Service
Ron Jones, Portland State University
Ephraim King, U.S. Environmental Protection Agency
Greg Knecht, Florida Department of Environmental Protection

Steve Kopecky, U.S. Army Corps of Engineers
Timothy Lang, University of Florida
Dexter Lehtinen, Miccosukee Tribe of Indians
Andy LoSchiavo, U.S. Army Corps of Engineers
Joette Lorion, Miccosukee Tribe of Indians
Tom MacVicar, MacVicar, Federico, and Lamb
Michael Magley, U.S. Army Corps of Engineers
Chris McVoy, South Florida Water Management District
June Mirecki, U.S. Army Corps of Engineers
Barron Moody, Florida Fish and Wildlife Conservation Commission
Temperince Morgan, South Florida Water Management District
Cal Neidrauer, South Florida Water Management District
Jayantha Obeysekera, South Florida Water Management District
John Ogden, Audubon
Leonard Pearlstine, National Park Service
Sylvia Pelizza, U.S. Fish and Wildlife Service
Susie Perez-Quinn, Office of Sen. Bill Nelson
Mark Perry, Everglades Coalition
Tracey Piccone, South Florida Water Management District
Garth Redfield, South Florida Water Management District
Pam Repp, U.S. Fish and Wildlife Service
Terry Rice, Miccosukee Tribe of Indians
LeRoy Rodgers, South Florida Water Management District
David Rudnick, South Florida Water Management District
Terrence “Rock” Salt, U.S. Department of the Interior (formerly)
Lynn Scarlett, U.S. Department of the Interior (formerly)
Dan Scheidt, U.S. Environmental Protection Agency
Len Shabman, Resources for the Future
Fred Sklar, South Florida Water Management District
Paul Souza, U.S. Fish and Wildlife Service
Susan Sylvester, South Florida Water Management District
Kimberly Taplin, U.S. Army Corps of Engineers
Tom Teets, South Florida Water Management District
Tim Towles, Florida Fish and Wildlife Conservation Commission
Steve Traxler, U.S. Fish and Wildlife Service
Tiffany Trent, U.S. Fish and Wildlife Service
Tom Van Lent, Everglades Foundation
Bob Verrastro, South Florida Water Management District
Mike Waldon, U.S. Fish and Wildlife Service
Bill Walker, Independent Consultant
Dewey Worth, South Florida Water Management District
John Zediak, U.S. Army Corps of Engineers

Preface

The Greater Everglades Ecosystem encompasses some of America's most diverse and distinctive wetland landscapes. These include the sloughs and lakes of the upper Kissimmee River watershed, the meandering Kissimmee River and its broad floodplain, vast Lake Okeechobee, the sawgrass plain, ridge and slough wetlands and marl prairies south of the lake, and ultimately the bays and estuaries of the Florida peninsula. Distinctive in their own right, these landscapes are hydrologically and ecologically connected across more than 220 miles from north to south and across 18,000 square miles of southern Florida.

Everglades landscapes are also connected by human cultures and activities. For 200 years they have been the homelands of the Seminole and Miccosukee Tribes. Now more than 7 million people reside in South Florida, and at least five times that many visit South Florida each year. Agriculture and urban development have reduced the Everglades to less than half of its historical extent. The remnant ecosystem is intensely managed through the Central and South Florida project's extensive network of canals, levees, and pumping stations to serve multiple competing demands for developable land, water supply, flood control, recreation, and environmental conservation.

Continuing environmental degradation and endangerment of wildlife species has led to a long series of efforts to protect and restore the remaining Everglades. In 1999, the state of Florida and the federal government agreed to a multi-decadal, multi-billion dollar Comprehensive Everglades Restoration Plan (CERP) to protect and restore the remaining Everglades while meeting growing demands for water supply and flood control. Like the Kissimmee River Restoration in the northern part of the system, the CERP is being managed by the U.S. Army Corps of Engineers (USACE) and the South Florida Water Management District (SFWMD).

In authorizing the CERP, the U.S. Congress mandated periodic independent reviews of progress toward restoring the natural system in the Everglades. The National Research Council's (NRC's) Committee on Independent Scientific

Review of Everglades Restoration Progress, or CISRERP, was formed for this purpose in 2004. This report, which is the third in a series of biennial evaluations that are expected to continue for the duration of the CERP, reflects the concerted efforts of 13 committee members and 3 NRC staff representing a wide range of scientific and engineering expertise. Our committee met six times over a period of 18 months including four times in Florida and once in Washington, D.C. We reviewed a large volume of written material and heard oral presentations from state and federal agency personnel, academic researchers, interest groups, and members of the public. The report presents our consensus view of restoration accomplishments and emerging challenges, primarily during the past 2 years but also over the 10 years since the project was authorized.

It has been a particularly eventful period for Everglades restoration; ground has been broken on several important projects, and several others are set to begin. There have been important advances in scientific understanding. At the same time, challenges in achieving water quality standards and water storage and re-distribution have become more apparent. The number of activities and volume of information associated with Everglades restoration have grown truly daunting. I appreciate how much time, attention, and thought every member of this committee has invested in absorbing and digesting so much material. I especially appreciate their careful, rigorous analyses, their expert judgment, and their constructive comments and reviews.

Our committee is indebted to many individuals for their contributions of information and resources. Specifically, we appreciate the efforts of our committee's technical liaisons—David Tipple (USACE), Glenn Landers (USACE), Larry Gerry (SFWMD), Robert Johnson (National Park Service), and Todd Hopkins (U.S. Fish and Wildlife Service)—who assisted the committee with numerous information requests and helped the committee utilize the vast resources of agency expertise when needed. Many others educated our committee on the complexities of Everglades restoration through their presentations, field trips, and public comments (see Acknowledgments).

The committee has been fortunate to have the support and collaboration of an excellent NRC staff: Stephanie Johnson and David Policansky have been extraordinary sources of information and advice and have contributed significantly to this report. Michael Stoeber has provided superb support during and between meetings and has also been instrumental in producing the report. I speak for the entire committee in expressing our profound respect and gratitude.

This report was reviewed in draft form by individuals chosen for their breadth of perspectives and technical expertise in accordance with the procedures approved by the National Academies' Report Review Committee. The purpose of this independent review was to provide candid and critical comments to assist the institution in ensuring that its published report is scientifically

credible and that it meets institutional standards for objectivity, evidence, and responsiveness to the study charge. The reviewer comments and draft manuscript remain confidential to protect the deliberative process. We thank the following reviewers for their helpful suggestions, all of which were considered and many of which were wholly or partly incorporated in the final report: Richard M. Adams, Oregon State University; Linda K. Blum, University of Virginia; Aaron Higer, U.S. Geological Survey; John Ogden, Audubon of Florida; Stephen Polasky, University of Minnesota; Curt Richardson, Duke University; Donald I. Siegel, Syracuse University; John C. Volin, University of Connecticut.

Although these reviewers provided many constructive comments and suggestions, they were not asked to endorse the conclusions and recommendations nor did they see the final draft of the report before its release. The review of this report was overseen by Gordon Orians, University of Washington, and Frank Stillinger, Princeton University. Appointed by the NRC, they were responsible for making certain that an independent examination of this report was carried out in accordance with institutional procedures and that all review comments received full consideration. Responsibility for the final content of this report rests entirely with the authoring committee and the NRC.

Frank W. Davis, *Chair*
Committee on Independent Scientific Review
of Everglades Restoration Progress (CISERP)

Contents

ABSTRACT	1
SUMMARY	3
1 INTRODUCTION	15
The National Research Council and Everglades Restoration, <i>16</i>	
Report Organization, <i>21</i>	
2 THE RESTORATION PLAN IN CONTEXT	23
The South Florida Ecosystem's Decline, <i>23</i>	
South Florida Ecosystem Restoration Goals, <i>31</i>	
Restoration Activities, <i>34</i>	
10 Years Later: The Changing Environmental and Socioeconomic Context for the CERP, <i>38</i>	
Conclusions and Recommendations, <i>60</i>	
3 IMPLEMENTATION PROGRESS	62
CERP Restoration Implementation, <i>62</i>	
Non-CERP Restoration Implementation, <i>90</i>	
Programmatic Progress, <i>102</i>	
Conclusions and Recommendations, <i>109</i>	
4 CHALLENGES IN RESTORING WATER TIMING, FLOW, AND DISTRIBUTION	112
Past and Future Changes to South Florida's Water Budgets and Flow Regimes, <i>112</i>	
Partial Hydrologic Restoration and Spatial Tradeoffs, <i>119</i>	
Case Study: Restoring Water Flows in WCA-3, <i>129</i>	
Conclusions and Recommendations, <i>147</i>	

5	CHALLENGES IN RESTORING WATER QUALITY	149
	Pre-Drainage Nutrient Conditions, <i>149</i>	
	Legal Context for Water Quality in the South Florida Ecosystem, <i>150</i>	
	Toward a Systemwide Phosphorus Budget, <i>158</i>	
	Effectiveness of Current Phosphorus Management Practices, <i>163</i>	
	Cost-Effectiveness Considerations, <i>188</i>	
	Sulfur, Mercury, and Phosphorus Interactions in the Everglades, <i>190</i>	
	Calcium, Alkalinity, and Specific Conductance, <i>197</i>	
	Conclusions and Recommendations, <i>201</i>	
6	USE OF SCIENCE IN DECISION MAKING	205
	Adaptive Management, <i>206</i>	
	Monitoring and Assessment Plan, <i>214</i>	
	Research and Modeling Tools to Support Restoration, <i>221</i>	
	Economic Valuation of Ecosystem Services for Everglades Decision Making, <i>237</i>	
	Conclusions and Recommendations, <i>241</i>	
	REFERENCES	244
	ACRONYMS	263
	GLOSSARY	266
	APPENDIXES	
A	National Research Council Everglades Reports	281
B	Timeline of Significant Events in South Florida Ecosystem Management and Restoration	287
C	Status of Key Non-CERP Projects	291
D	Regulation Schedule for WCA-3A	301
E	Water Science and Technology Board, Board on Environmental Studies and Toxicology	303
F	Biographical Sketches of Committee Members and Staff	305

Abstract

This report is the third in a series of biennial independent scientific reviews of progress toward Everglades restoration that are mandated by the Water Resources Development Act of 2000. The reviews focus on restoration progress, scientific and engineering issues that could affect that progress, significant accomplishments of the restoration, and monitoring and assessment protocols. This report focuses on progress since the previous report, released in 2008, and issues relevant to these past two years.

Natural system restoration progress from the Comprehensive Everglades Restoration Plan (CERP) remains slow, but in the past two years there have been noteworthy improvements in the pace of restoration and in the relationship between the federal and state partners. Federal CERP funding, which previously had not kept pace with state funding, has increased, which has allowed continued progress as state funding has declined. Four CERP projects, four pilot projects, and several non-CERP projects are under construction, notably the Tamiami Trail bridge. The science program continues to provide a sound basis for decision making, although clearer mechanisms for integrating science into restoration decision making are needed. This new momentum should be viewed only as a beginning; all early CERP projects are behind the original schedule, some of them by more than a decade. The restoration plan still has decades before completion, even without additional delays, and it will need political commitment to long-term funding.

Several important challenges related to water quality and water quantity have become clear during the past two years, highlighting the difficulty of simultaneously achieving restoration goals for all ecosystem components in all portions of the Everglades. For example, although wading bird numbers have increased recently throughout the Everglades and populations of the Cape Sable seaside sparrow have stabilized in Everglades National Park, the continued decline of snail kites to extremely low numbers and the continued stress to tree islands in Water Conservation Area 3A have led to growing public con-

troversty and concerns about management. Restoring hydrologic conditions while providing adequate storage and meeting water quality goals is also a difficult challenge. Achieving water quality goals throughout the South Florida ecosystem, especially for phosphorus content, will be enormously costly and will take decades to achieve. Some tradeoffs are inevitable in the CERP, given the reduced extent, altered topography, and reduced storage of the modern Everglades, and integrated hydrologic, ecological, and biogeochemical models and multi-objective decision analysis tools are needed to help evaluate design and management alternatives. Also, rigorous scientific analyses of the tradeoffs between water quality and quantity are needed to inform future prioritization and funding decisions. The analyses should include consideration of the time scales, spatial dependencies, and degree of reversibility of damage from continued degradation to various ecosystem components. Understanding and communicating these tradeoffs to decision makers and stakeholders are critical aspects of CERP planning and implementation.

Despite these challenges, experience with some projects, such as the restoration of the Kissimmee River, and recent progress on some critical CERP and non-CERP projects, lead to optimism that if restoration progress continues, substantial ecological benefits will accrue to the ecosystem, even if the effort does not achieve all the restoration goals originally envisioned by the CERP.

Summary

The Florida Everglades, a large and diverse aquatic ecosystem, has been dramatically altered over the past century by an extensive water control infrastructure, designed to increase regional economic productivity through improved flood control, urban water supply, and agricultural production. The remnants of the original Everglades now compete for vital water with urban and agricultural interests and are impaired by contaminated runoff from these two activities. The Comprehensive Everglades Restoration Project (CERP), a joint effort led by the state and the federal government launched in 2000, seeks to reverse the general decline of the ecosystem. This multi-billion dollar project was envisioned as a 30-year effort to achieve ecological restoration by restoring the hydrologic characteristics of the Everglades, where feasible, and to create a water system that simultaneously serves the needs of the natural and the human systems of South Florida (Figure S-1).

The National Research Council (NRC) established the Committee on Independent Scientific Review of Everglades Restoration Progress (CISRERP) in 2004 in response to a request from the U.S. Army Corps of Engineers (USACE), with support from the South Florida Water Management District (SFWMD) and the U.S. Department of the Interior (DOI), based on Congress's mandate in the Water Resources Development Act of 2000 (WRDA 2000). The committee is charged to submit biennial reports that review the CERP's progress in restoring the natural system (see Box S-1). This is the committee's third report in a series of biennial evaluations.

RESTORATION PROGRESS

The CERP, led by the USACE and the SFWMD, consists primarily of projects to increase storage capacity (e.g., conventional surface-water reservoirs, aquifer storage and recovery, in-ground reservoirs), improve water quality (e.g., stormwater treatment areas [STAs]), reduce loss of water from the system (e.g.,



FIGURE S-1 The South Florida ecosystem, which shares the same boundaries as the South Florida Water Management District. © International Mapping Associates

BOX S-1 Statement of Task

This congressionally mandated activity will review the progress toward achieving the restoration goals of the Comprehensive Everglades Restoration Plan (CERP). The committee meets approximately four times annually to receive briefings on the current status of the CERP and on scientific issues involved in implementing the restoration plan, and it publishes biennial reports providing:

1. assessment of progress in restoring the natural system, which is defined by section 601(a) of WRDA 2000 as all the land and water managed by the federal government and state within the South Florida ecosystem;
2. discussion of significant accomplishments of the restoration;
3. discussion and evaluation of specific scientific and engineering issues that may impact progress in achieving the natural system restoration goals of the Plan; and
4. independent review of monitoring and assessment protocols to be used for evaluation of CERP progress (e.g., CERP performance measures, annual assessment reports, assessment strategies).

seepage management, water reuse, conservation), and reestablish pre-drainage hydrologic patterns wherever possible (e.g., removing barriers to sheet flow, rainfall-driven water management). The CERP builds upon other activities of the state and the federal government aimed at restoration (hereafter, non-CERP activities), many of which are essential to the success of the CERP in achieving its restoration goals.

Natural system restoration progress from the Comprehensive Everglades Restoration Plan (CERP) remains slow. This committee reaffirms its predecessor's conclusions (NRC, 2008) that continued declines of some aspects of the ecosystem coupled with environmental and societal changes make accelerated progress in Everglades restoration even more important. A review of the changing context for the CERP over the past decade reveals positive as well as negative trends. The decade brought 2 major droughts and 12 tropical storms, creating extensive challenges for water managers. Some species, particularly wading birds, Cape Sable seaside sparrows, and panthers appear to be increasing or stable, while others, such as the snail kite, have declined. Tree island habitats continue to decline. Despite some impressive control efforts, especially for plants, invasive species continue to present major challenges, and the invasive exotic animals have few effective controls. Despite large investments in STAs and long-term water quality improvements from these efforts, water quality violations suggest that more work is needed. Meanwhile, the economic downturn has led to shortfalls in revenue for the SFWMD, although the downturn has also

resulted in lower costs of construction for some key projects. Increased water conservation efforts as well as slower population growth have kept urban water demand substantially lower than was projected when the CERP was designed.

During the past two years the restoration program has made tangible progress, and four CERP projects are now under construction. Continued federal commitment is especially important at this time. The Everglades restoration program has completed the arduous federal project planning and authorization processes for three projects and is now moving forward with construction of the Picayune Strand project with federal funding. Additionally, despite budget challenges, the state of Florida continues to expedite the construction of three projects (C-111 Spreader Canal, Biscayne Bay Coastal Wetlands, and Lakeside Ranch Stormwater Treatment Area). After years of delay, it is critically important to maintain this momentum to minimize further degradation of the system during CERP implementation.

Some restoration benefits can be attributed to partial restoration of Picayune Strand; however, the completion of additional ongoing and planned projects will be required to see substantial restoration benefits for the Everglades ecosystem. The SFWMD reports that plugging one canal in Picayune Strand raised water tables on approximately 13,000 acres of wetland habitat, representing partial hydrologic restoration on approximately one-fourth of the project area. Construction is also under way on the C-111 Spreader Canal and the Biscayne Bay Coastal Wetlands projects, but no significant restoration benefits have yet resulted from these efforts. Each of these projects is being implemented in phases to deliver early restoration benefits when possible with available funding.

Pilot projects and field-scale experiments are addressing some important design uncertainties but could be better linked to decision making and implementation. In addition to the originally conceived CERP pilot projects, CERP planners have recently initiated two field-scale experiments (the C-111 Spreader Canal design test and the Decomp Physical Model). These projects are intended to reduce design uncertainties that were points of contention among stakeholders, which limited progress on project planning. The C-111 design test will address important hydrologic uncertainties; additional pilot components are needed to address the potential impacts of elevated nutrients on receiving wetlands. The Decomp Physical Model will provide information on hydraulic, hydrologic, and short-term ecological differences between canal backfilling options and will improve understanding of the hydrological response of WCA-3B to re-watering, but the experiment will likely require additional replication to settle the current debate over the efficacy of different canal treatments. CERP scientists and planners should consider other means of synthesizing and communicating results beyond traditional hypothesis tests to facilitate stakeholder discussions and decision making under uncertainty.

Aquifer storage and recovery (ASR) pilot studies have contributed valuable hydrogeologic and geochemical information, but the administrative delays, site limitations, funding constraints, and arsenic leaching encountered are indicative of serious challenges facing large-scale use of ASR. The final ASR pilot report should address the impacts of these factors on use of ASR at the unprecedented scale envisioned for the CERP and should compare the long-term costs and benefits of ASR against other less energy-intensive storage alternatives.

Initiation of construction of a 1-mile bridge on the Tamiami Trail is an important, albeit partial, step forward. NRC (2008) called the Modified Water Deliveries to Everglades National Park (Mod Waters) Project, of which the bridge is one component, “one of the most discouraging stories in Everglades restoration” and stated that if the downsized 1-mile bridge could not be built, the outlook for the CERP was dismal. With leadership from the administration and Congress, the federal government was able to overcome numerous obstacles to ultimately break ground on the project in December 2009. Although the benefits of the 1-mile bridge represent only a fraction of those envisioned in earlier Mod Waters plans, planning is under way to consider additional bridging that could take advantage of a downturn in construction costs.

The River of Grass initiative could create options for additional water storage and water quality treatment to help meet CERP objectives. The SFWMD governing board recently approved the purchase of nearly 27,000 acres of U.S. Sugar Corporation lands—substantially less than previously announced—near areas with historically high phosphorus loads. These lands could help the SFWMD come into compliance with current water quality requirements, yet this represents only a small step toward the goals of the River of Grass initiative. Prior to this announcement, the SFWMD had facilitated an engaging and inclusive River of Grass planning process and had created an impressive set of data visualization tools to support the effort. As of mid-2010, the specific benefits that will accrue to the CERP from the River of Grass initiative cannot be determined, because the planning and design process has not been completed and the availability of funding to support future land purchases is unknown. Also, it remains unclear how successfully other political and economic constraints can or will be addressed for the remaining “option” lands (e.g., reality of land swaps, opportunity costs, stakeholder concerns) and how the initiative will be coordinated with the CERP.

Given the slower than anticipated pace of implementation and unreliable funding schedule, projects should be scheduled with the aim of achieving substantial restoration benefits as soon as possible. The latest Integrated Delivery Schedule appears consistent with this goal and should generate substantial restoration benefits by 2020. Although many projects have been delayed, aggressive schedules have been maintained for the WCA 3 Decompartmentalization

(Decomp) project, seepage management, and critical foundation projects (as of the March 2010 published schedule). These projects offer significant restoration benefits to the remnant Everglades ecosystem, but the benefits cannot be fully realized without the provision of additional water, which will require substantial new storage and associated water quality treatment.

Maintaining political and public support for Everglades restoration will be critical to future CERP progress. Multiple decades of sustained commitment and a high level of public funding will be needed to complete the CERP. Maintaining this commitment will be a continuing challenge and will require near-term demonstration of significant public and environmental benefits as evidenced through the CERP's monitoring and assessment program.

PROGRESS IN SCIENCE SUPPORT FOR DECISION MAKING

Research efforts are providing a sound basis for critical CERP decision making. Research during the past few years has led to notable advances in our understanding of climate trends in South Florida and the sensitivity of the regional water management system to changes in climate and sea level. Research has also improved understanding of the pre-drainage Everglades and has clarified the key parameters governing the formation and maintenance of landscape features in the ridge and slough ecosystem. Also under way are two major science synthesis efforts directed toward answering key questions relevant to restoration management.

Progress continues on improving the Monitoring and Assessment Plan (MAP) and on building a baseline of monitoring data by which restoration progress will be judged. MAP 2009, an update to the MAP report released in 2004, largely addressed the prior NRC committee's concerns about monitoring and assessment (NRC, 2008), although a full evaluation of the MAP cannot take place until additional on-the-ground restoration progress has taken place. The Science Coordination Group, working with RECOVER scientists, developed a stop-light indicator system that substantially improves the communication of ecosystem status to the public.

The CERP has laid the foundations for adaptive management of Everglades restoration and should now put theory into practice. To do so will require stronger institutional mechanisms for obtaining scientific feedback to planning, management, and implementation decisions. Project planning should explicitly provide for adaptive management in the context of both project-specific and systemwide performance monitoring and evaluation. To ensure stronger coupling of engineering design and operations with ecosystem assessment, project monitoring should be well integrated with systemwide monitoring and assessment.

The effectiveness of the linkages between science and decision making

should be examined by CERP leadership. Linking science with policy and management decisions is critically important to achieving restoration goals, but the effectiveness of current mechanisms in providing such linkage has been questioned by some in the restoration community. The committee encourages CERP leadership to examine this issue and to consider mechanisms to improve the communication of relevant scientific findings to decision makers. The committee also recommends greater clarity and transparency in the integration of science into CERP policy and management decisions.

Constructive stakeholder engagement and interagency coordination are key elements of CERP adaptive management. To improve stakeholder engagement, the USACE and SFWMD should formally evaluate and strengthen the CERP's efforts at outreach and public engagement, and implement a process to monitor the efforts' effectiveness and ensure iterative improvement.

Little recent progress has been made in developing integrated hydrologic, ecological, and biogeochemical models to inform restoration decision making and to provide input for adaptive management. Hydrologic modeling has been the primary focus of CERP model development efforts, and substantial progress has been made on the Natural System Regional Simulation Model (NSRSM) and in subregional applications of the South Florida Regional Simulation Model (RSM). In contrast, efforts to develop ecological models, linked ecological-hydrologic models, and biogeochemical or sediment transport models are notably minimal. As a result, project planning and decision making proceeds without complete information as to the ecological and water quality impacts at both a project and regional scale.

Although the concept of economic valuation of ecosystem services is a promising and important one, the committee does not see near-term benefits to its use in the CERP. Developing accurate and defensible estimates of the economic values of ecosystem services in the Everglades will require careful, deliberate, original research and analysis that integrates assessments of ecosystem functions, services, and individual value estimates. Prerequisites for such an analysis are integrated hydrologic, ecological, and biogeochemical models that can predict the ecosystem services that will likely result from alternative restoration activities; even with such models, the analysis would require a large effort. For this reason, economic valuation of ecosystem services is unlikely to assist near-term decision making. Everglades restoration planners should be alert to specific opportunities when the economic valuation of ecosystem services has the potential to be useful, and especially, to improve the methods for economic valuation of ecosystem services and adapt them to the Everglades.

RESTORATION CHALLENGES

Everglades restoration is premised on “getting the water right” by re-establishing the hydrologic regime and biological characteristics that defined undisturbed South Florida ecosystems, including a large extent of interconnected wetlands, extremely low concentrations of nutrients in freshwater wetlands, sheet flow, healthy and productive estuaries, resilient plant communities, and abundant and viable populations of native wildlife. In practice, “getting the water right” means re-engineering and re-operating the Central and South Florida (C&SF) Project to improve the quantity, quality, timing, and distribution of freshwater flows in the South Florida ecosystem, reducing pollution sources in the basin, and treating polluted surface waters as necessary.

Challenges in Restoring Water Timing, Flow, and Distribution

The reduced extent, altered topography, and reduced storage of the modern Everglades make it infeasible to achieve the same degree of restoration throughout the remnant system. Hydrologic conditions may even worsen in some areas in order to achieve desired outcomes in others. In particular, northern Water Conservation Areas (WCA)-3A and -3B (Figure S-1) have experienced substantial drying, peat loss, and subsidence, making it difficult to maintain suitable water flow, levels, and hydroperiods there.

Hydrologic interdependencies of regions within the Everglades and the associated ecological tradeoffs that result from restoration and water management decisions need to be rigorously analyzed from a whole-system perspective and clearly communicated to decision makers and stakeholders. The CERP lacks a formal approach for evaluating in a transparent way the systemwide benefits of alternative restoration plans or policies, although RECOVER scientists have made good use of hydrologic models and performance measures to evaluate the design and staging of the CERP. RECOVER, in collaboration with water managers and decision makers, should develop evaluation methods to quantify and integrate across the tradeoffs required to sustain Everglades’ species and features to assess the systemwide restoration benefits. Any consideration of the ecological risks associated with water management should consider the timescales over which adverse ecological outcomes might be reversible, if they are at all.

Increasing water storage (and associated water quality treatment) is a major near-term priority. Over the next 5-10 years, CERP and pre-CERP projects will improve the conveyance and distribution of water in southern WCA-3A and Everglades National Park. But until additional water of sufficient quality becomes available, the restoration benefits will be modest and could result in shorter hydroperiods and more severe dry-down events in northern WCA-2A and

northern WCA-3A. The Integrated Delivery Schedule does not currently have a plan for water storage to support planned projects in the remnant Everglades ecosystem, aside from the stalled Everglades Agricultural Area A-1 Reservoir, and the benefits of the A-1 Reservoir to the remnant Everglades remain unclear.

WCA-3 is a growing focus of public controversy and management concern because of its location and the way the entire system is operated to manage water distribution and quality. WCA-3A supports extensive and relatively intact Everglades landscapes including ridge and slough patterns and tree islands, and it provides critical habitat for endangered species, such as the snail kite and wood stork. It is the homeland of the Miccosukee Tribe of Indians and supports the tribe members' traditional and contemporary lifestyles. Over the past decade, however, there have been drastic declines in snail kite numbers and nesting success in WCA-3A, as well as continued slow declines in tree island size and number. The imminent loss of the snail kite from WCA-3A may precipitate a crisis in water management. To some degree, this situation has been exacerbated by the current operation of the compartmentalized Everglades that alters flows across the Tamiami Trail to restore Cape Sable seaside sparrows and ecosystem functioning in Everglades National Park.

In light of the rapidly deteriorating conditions in WCA-3A, improvements in operations could lead to important near-term restoration progress. The committee commends the cooperative, multi-objective approach to improve near-term operations that is reflected in the Everglades Restoration Transition Plan and encourages continuation of this approach, supported by rigorous scientific analysis and decision tools, beyond the current November 2010 end point. This process has the potential to align water management in the water conservation areas with a schedule that responds more flexibly to real-time conditions.

Improved species models and multi-objective decision analysis tools are urgently needed to provide more rigorous scientific support for water management decisions. Multi-objective decision tools can be used to help evaluate hydrologic effects and water-level management options on threatened species, ecosystem features such as tree islands, and critical ecosystem processes.

Challenges in Restoring Water Quality

Ten years after the CERP was launched, "getting the water right" is proving to be more difficult and expensive than originally anticipated. It has taken more than 60 years for the ecosystem to degrade to its current state, and it will likely take a similar timeframe or longer to restore. Due to legacy phosphorus storage in the Lake Okeechobee watershed, the lake itself, and the Everglades Agricultural Area, current phosphorus loadings into the system could persist for decades. **Attaining water quality goals throughout the system is likely to be very costly**

and take several decades of continued commitment to a systemwide, integrated planning and design effort that simultaneously addresses source controls, storage, and treatment over a range of timescales.

The current acreage of stormwater treatment areas (STAs), as managed, is not sufficient to treat existing water flows and phosphorus loads into the Everglades Protection Area. Although new construction of STAs is under way in Compartments B and C, these STAs are located far from where the recent Consent Decree violations have occurred. With increased volumes of water planned for the CERP, substantially more water quality treatment and/or additional load reductions will be needed if the new flows are to meet the water quality criteria. If these new CERP loads were addressed with STAs alone, an estimated 54,000 additional acres of STAs would be required, costing approximately \$1.1 billion to construct, \$27 million per year to operate and maintain, and approximately \$1.1 billion to refurbish every 20 to 25 years (in 2010 dollars). The U.S. Environmental Protection Agency's recently announced phosphorus and nitrogen water quality standards for lakes, rivers, and canals introduce additional technical and financial challenges.

The SFWMD should complete a comprehensive scientific, technical, and cost-effectiveness analysis as a basis for assessing potential short- and long-term restoration alternatives and for optimizing restoration outcomes given state and federal financial constraints. This analysis is needed to facilitate management decisions that focus on improving systemwide water quality, bringing the watershed into compliance with the Lake Okeechobee total maximum daily load (TMDL), and addressing recent violations of the Consent Decree. In addition to considering additional treatment and source control, this analysis should evaluate urban and agricultural water supply management approaches and accelerated sequencing for seepage management projects to determine whether changes could address water quality and water quantity concerns in a more efficient manner.

Additional information on phosphorus mass balances, particularly within the Everglades Agricultural Area, is needed to support effective decision making. NRC (2008) recommended a systemwide accounting for phosphorus and other contaminants such as sulfur, nitrogen, calcium, and mercury, and this accounting remains a pressing need. There are notable gaps in the published phosphorus budgets between Lake Okeechobee and the inflows to the STAs and also in the contributions from atmospheric deposition for phosphorus and other elements. The lack of information synthesis of inputs and pathways of phosphorus and other contaminants in key areas, such as the Everglades Agricultural Area, hinders the development of targeted strategies to improve water quality management.

A rigorous research, analysis, and modeling program is needed to develop improved best management practices and to examine the long-term sustain-

ability and performance of STAs to meet the desired outflow water quality. To support the comprehensive scientific, technical, and cost-effectiveness analysis recommended above, additional research is needed in the following areas:

- **STA sustainability and performance.** The SFWMD's extensive STA soil and water quality monitoring program should be supported by a systematic research program that evaluates the long-term ability of STAs to sustain or improve upon their current level of functioning. Further research should examine the biogeochemistry, vegetation dynamics, and hydrology of the STAs, and should couple the resultant data with predictive models to improve performance and support management decisions. Useful improvements could also be realized through an external peer review of the STA monitoring, design criteria, and modeling and supportive research program.

- **Source control effectiveness.** A rigorous research, monitoring, and modeling program focused on developing improved best management practices is needed to improve the efficiency of phosphorus source control efforts and to inform systemwide phosphorus management decisions. Long-term monitoring of the efficacy and costs of best management practice implementation across multiple sites will be required to evaluate source control practices across variable hydrologic, geomorphologic, and soil regimes present in the South Florida ecosystem and to validate and build confidence in predictive models.

Given that restoration as originally envisioned in the CERP remains decades away and the ecosystem continues to decline, CERP agencies should conduct a rigorous scientific analysis of the short- and long-term tradeoffs between water quality and quantity for the Everglades ecosystem. The committee does not endorse such tradeoffs at this time, because scientific analyses to explain the repercussions of such decisions are lacking. However, the scientific analysis of potential tradeoffs is critical to inform future water management decisions, including the prioritization of projects. In particular, the analysis should address the following questions:

- What are the short- and long-term consequences of providing too little water to the Everglades ecosystem but maintaining sufficient quality?
- What are the short- and long-term consequences of providing water of lower quality to the Everglades ecosystem but maintaining sufficient flows?
- Are the negative consequences reversible, and if so, within what timeframes?

Effective water quality management would be best served by consideration of a multi-contaminant approach in the future. Water quality conditions in the

Everglades are affected not only by the input of contaminants, but also by the inputs of other elements that alter their behavior. For example, the bioavailability of mercury and its accumulation in fish and other wildlife appears to be controlled not only by inputs of mercury, but also by the supply of sulfate, phosphorus, and dissolved organic carbon. Likewise the transport and removal of phosphorus may be coupled with the supply of calcium in Lake Okeechobee, the STAs, and other portions of the Everglades. Additional research is also needed to clarify the linkages between water quality constituents to support sound multi-contaminant water management decisions.

OVERALL EVALUATION OF PROGRESS AND CHALLENGES

Although natural system restoration progress from the CERP remains slow, in the past two years, there have been noteworthy improvements in the pace of implementation and in the relationship between the federal and state partners. Federal CERP funding has increased, which has allowed continued progress as state funding has declined. The science program continues to provide a sound basis for decision making, but more transparent mechanisms of integrating science into decision making are needed. Continued public support and political commitment to long-term funding will be needed for the restoration plan to be completed.

Despite progress in implementation, several important challenges related to water quality and water quantity have become clear over the past two years, highlighting the difficulty of simultaneously achieving restoration goals for all ecosystem components in all portions of the Everglades. Achieving water quality goals for phosphorus in the South Florida ecosystem will be enormously costly and will take decades at least. Rigorous scientific analyses of potential conflicts among the hydrologic requirements of Everglades landscape features and species, and the tradeoffs between water quality and quantity, considering timescales of reversibility, are needed to inform future prioritization and funding decisions. Understanding and communicating these tradeoffs to stakeholders are critical aspects of CERP planning and implementation.

1

Introduction

The Florida Everglades, formerly a large and diverse aquatic ecosystem, has been dramatically altered over the past century by an extensive water control infrastructure designed to increase regional economic productivity through improved flood control, urban water supply, and agricultural production (Davis and Ogden, 1994; NRC, 2005). Shaped by the slow flow of water, its vast terrain of sawgrass plains, ridges, sloughs, and tree islands used to support a high diversity of plant and animal life. This natural landscape also served as a sanctuary for Native Americans. However, large-scale changes to the landscape have diminished the natural resources, and by the mid- to late-20th century, many of the area's defining natural characteristics had been lost. The remnants of the original Everglades (see Figure 1-1 and Box 1-1) now compete for vital water with urban and agricultural interests, and contaminated runoff from these two activities impairs the South Florida ecosystem.

Recognition of past declines in environmental quality, combined with continuing threats to the natural character of the remaining Everglades, led to initiation of the Comprehensive Everglades Restoration Plan (CERP) in the late 1990s. This unprecedented project envisioned the expenditure of billions of dollars in a multi-decadal effort to achieve ecological restoration by reestablishing the hydrologic characteristics of the Everglades, where feasible, and to create a water system that simultaneously serves the needs of both the natural and the human systems of South Florida. Within the social, economic, and political latticework of the 21st century, the restoration of the South Florida ecosystem is now under way and represents one of the most ambitious ecosystem renewal projects ever conceived. This report represents the third independent assessment of the CERP's progress by the Committee on Independent Scientific Review of Everglades Restoration Progress (CISRERP) of the National Research Council (NRC).

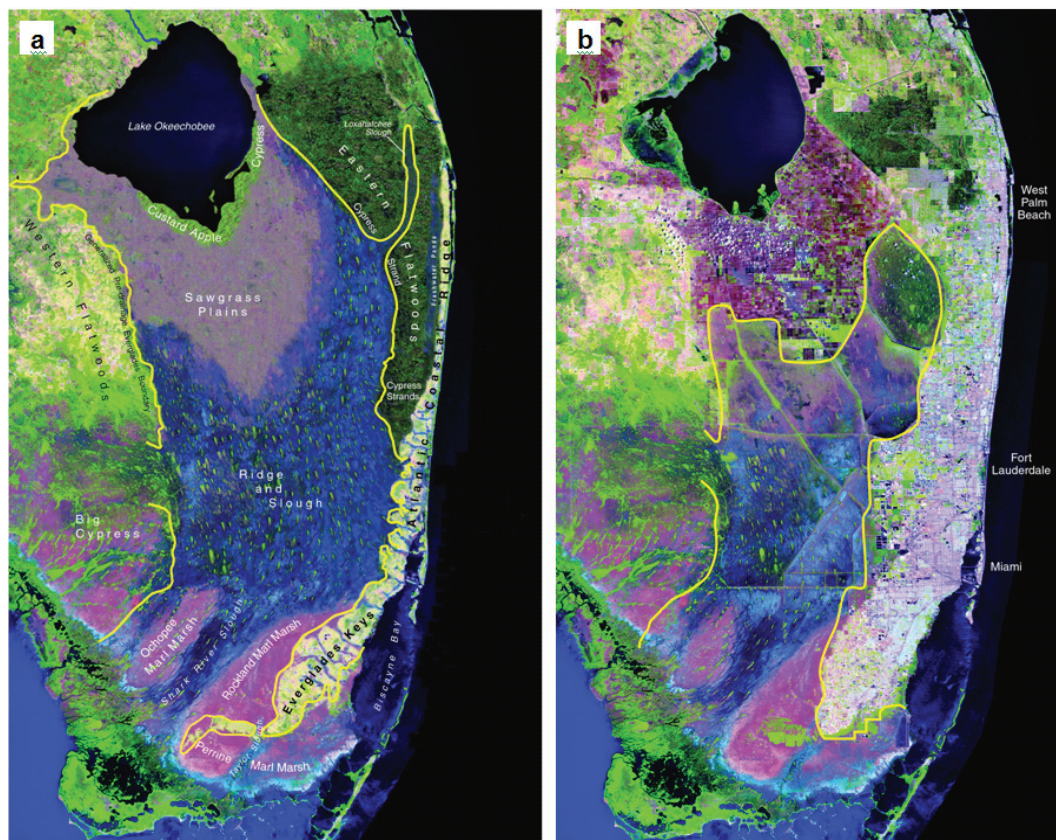

FIGURE 1-1 Reconstructed (a) pre-drainage (circa 1850) and (b) current (1994) satellite images of the Everglades ecosystem.

NOTE: The yellow line in (a) outlines the historical Everglades ecosystem, and the yellow line in (b) outlines the remnant Everglades ecosystem as of 1994.

SOURCE: Courtesy of C. McVoy, J. Obeysekera, and W. Said, South Florida Water Management District.

THE NATIONAL RESEARCH COUNCIL AND EVERGLADES RESTORATION

The NRC has been providing scientific and technical advice related to the Everglades restoration since 1999. The NRC's Committee on the Restoration of the Greater Everglades Ecosystem (CROGEE), which operated from 1999 until 2004, was formed at the request of the South Florida Ecosystem Restoration Task Force (Task Force), an intergovernmental body established to facilitate

BOX 1-1 Geographic Terms

To minimize confusion, this box defines some key geographic terms used throughout this report.

- The **Everglades**, the **Everglades ecosystem**, or the **remnant Everglades ecosystem** refers to the present areas of sawgrass, marl prairie, and other wetlands south of Lake Okeechobee (Figure 1-1b).
- The **original, historical, or pre-drainage Everglades** refers to the areas of sawgrass, marl prairie, and other wetlands south of Lake Okeechobee that existed prior to the construction of drainage canals beginning in the late 1800s (Figure 1-1a).
- The **Everglades watershed** is the drainage that encompasses the Everglades ecosystem but also includes the Kissimmee River watershed and other smaller watersheds north of Lake Okeechobee that ultimately supply water to the Everglades ecosystem.
- The **South Florida ecosystem** (also known as the Greater Everglades Ecosystem; see Figure 1-2) extends from the headwaters of the Kissimmee River near Orlando through Lake Okeechobee and the Everglades into Florida Bay and ultimately the Florida Keys. The boundaries of the South Florida ecosystem are determined by the boundaries of the South Florida Water Management District, the southernmost of the state's five water management districts, although they approximately delineate the boundaries of the South Florida watershed. This designation is important and is helpful to the restoration effort because, as many publications have made clear, taking a watershed approach to ecosystem restoration is likely to improve the results, especially when the ecosystem under consideration is as water dependent as the Everglades (NRC, 1999, 2004a).

The following represent legally defined geographic terms used in this report:

- The **Everglades Protection Area** is defined in the Everglades Forever Act as comprising Water Conservation Areas (WCAs) 1 (the Arthur R. Marshall Loxahatchee National Wildlife Refuge), 2A, 2B, 3A, and 3B and Everglades National Park.
- The **natural system** is legally defined in the Water Resources Development Act of 2000 (WRDA 2000) as all land and water managed by the federal government or the state within the South Florida ecosystem (see Figure 1-3). "The term 'natural system' includes (i) water conservation areas; (ii) sovereign submerged land; (iii) Everglades National Park; (iv) Biscayne National Park; (v) Big Cypress National Preserve; (vi) other Federal or State (including a political subdivision of a State) land that is designated and managed for conservation purposes; and (vii) any tribal land that is designated and managed for conservation purposes, as approved by the tribe" (WRDA 2000).

Many maps in this report include shorthand designations that use letters and numbers for man-made additions to the South Florida ecosystem. For example, canals are labeled C-#; levees and associated borrow canals as L-#; and structures, such as culverts, locks, pumps, spillways, control gates, and weirs, as S-#.

continued

BOX 1-1 Continued



FIGURE 1-2 The South Florida ecosystem. © International Mapping Associates

coordination in the restoration effort, and the committee produced six reports (NRC, 2001, 2002a,b, 2003a,b, 2005). The NRC's Panel to Review the Critical Ecosystem Studies Initiative produced an additional report in 2003 (NRC, 2003c; see Appendix A). The Water Resources Development Act of 2000 (WRDA 2000) mandated that the U.S. Department of the Army, the Department of the Interior (DOI), and the state of Florida, in consultation with the Task Force, establish an independent scientific review panel to evaluate progress toward achieving the natural system restoration goals of the CERP. The NRC's Committee on Independent Scientific Review of Everglades Restoration Progress was therefore established in 2004 under contract with the U.S. Army Corps of Engineers (USACE). After publication of each of the first and second biennial reviews (NRC, 2007, 2008; see Appendix A for the report summaries), some members rotated off the committee and some new members were added.

The committee is charged to submit biennial reports that address the following items:

1. An assessment of progress in restoring the natural system, which is defined by section 601(a) of WRDA 2000 as all of the land and water managed by the federal government and state within the South Florida ecosystem (see Figure 1-2 and Box 1-1);
2. A discussion of significant accomplishments of the restoration;
3. A discussion and evaluation of specific scientific and engineering issues that may impact progress in achieving the natural system restoration goals of the plan; and
4. An independent review of monitoring and assessment protocols to be used for evaluation of CERP progress (e.g., CERP performance measures, annual assessment reports, assessment strategies, etc.).

Given the broad charge, the complexity of the restoration, and the continually evolving circumstances, the committee did not presume it could cover all issues that affect restoration progress in any single report. Instead, this report covers restoration progress since 2008, high-priority scientific and engineering issues that the committee judged to be relevant to this timeframe, and other issues that have impacted the pace of progress. The committee focused particularly on issues for which the "timing was right"—that is, where the committee's advice could be useful relative to the decision making timeframes—and on topics that had not been fully addressed in past NRC Everglades reports. The committee also identified some perspectives on the changing context for restoration 10 years after the launching of the CERP in WRDA 2000, taking into account major recent developments that affect the future of CERP, such as the purchase of land from the U.S. Sugar Corporation and the recently announced

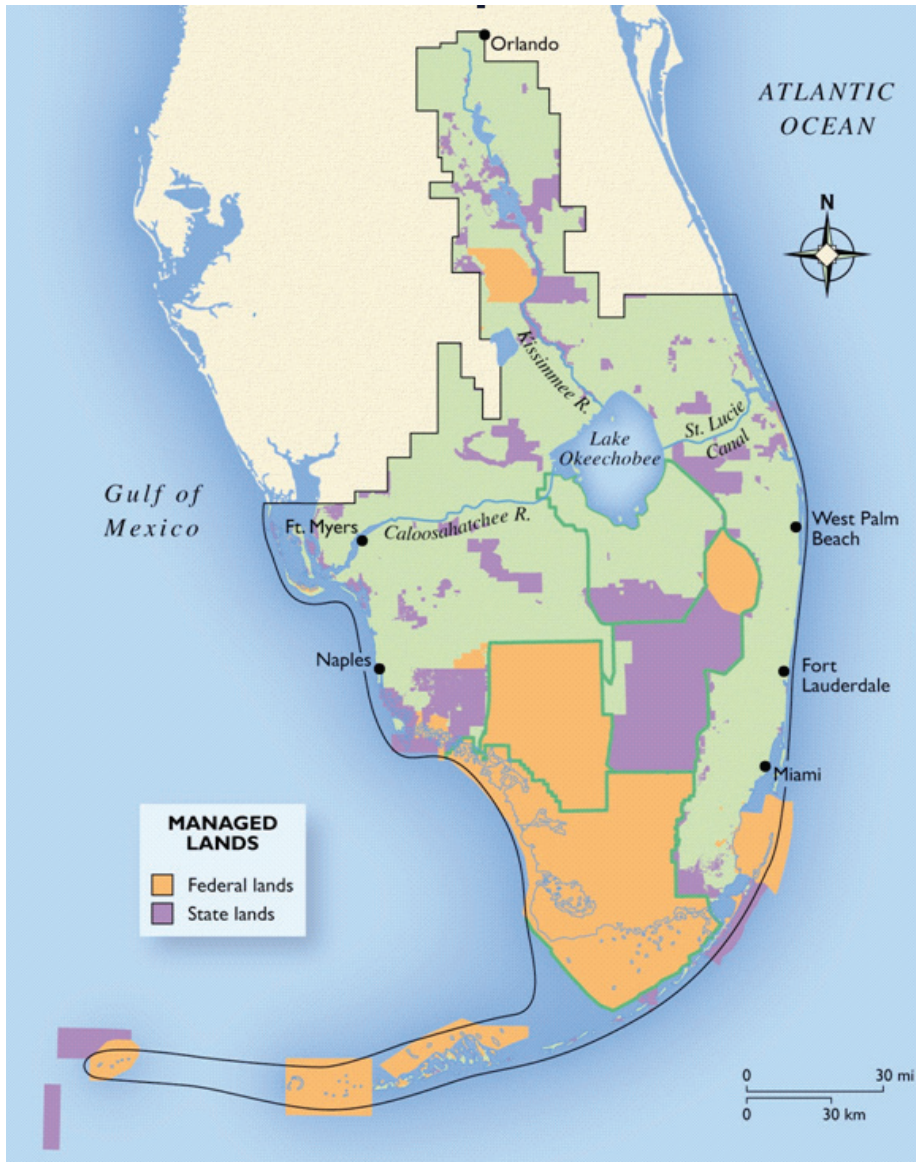

FIGURE 1-3 Land and waters managed by the state of Florida and the federal government as of December 2005 for conservation purposes within the South Florida ecosystem. SOURCE: Based on data compiled by Florida State University's Florida Natural Areas Inventory (<http://www.fnai.org/gisdata.cfm>). © International Mapping Associates

U.S. Environmental Protection Agency (EPA) numeric nutrient criteria for surface waters outside of the Everglades Protection Area.

Interested readers should look to past reports by this committee (NRC, 2007, 2008) to find detailed discussions of important topics, such as the human context for the CERP, climate change, Lake Okeechobee, Modified Water Deliveries to Everglades National Park, and incremental adaptive restoration, which are not repeated here. Some important issues, such as the recent Gulf of Mexico oil spill, were still unfolding at the time of the report's preparation, but these topics can be addressed in detail in future reports of this committee.

The committee met six times during the course of this review; received briefings at its public meetings from agencies, organizations, and individuals involved in the restoration, as well as from the public; and took several field trips to sites with restoration activities (see Acknowledgments) to help it evaluate restoration progress. In addition to information received at the meetings, the committee based its assessment of progress on information in relevant CERP and non-CERP restoration documents. The committee's conclusions and recommendations also were informed by a review of relevant scientific literature and the experience and knowledge of the committee members in their fields of expertise. The committee was unable to consider in any detail new materials received after February 2010.

REPORT ORGANIZATION

In Chapter 2, the committee provides an overview of the CERP in the context of other ongoing restoration activities and discusses the restoration goals that guide the overall effort. The changing context for the CERP is also discussed, considering the 10 years that have elapsed since the CERP was officially launched in response to WRDA 2000.

In Chapter 3 the committee analyzes the progress of CERP implementation, including recent developments at Picayune Strand, the C-111 Spreader Canal, and several pilot projects that are under way. Also discussed in the chapter are programmatic progress and issues.

In Chapter 4, the committee discusses the challenges of restoring water flow and distribution and the necessity of some tradeoffs in the restoration of the remnant ecosystem. To better illustrate these issues, the committee examines the hydrology and water management of WCA-3, which was chosen because of its central location in the restoration of the remnant Everglades ecosystem.

In Chapter 5, the committee focuses on "getting the water quality right." The chapter contains an overview of the regulatory and legal context for water quality in the Everglades and includes analysis of the current approaches for addressing water quality and opportunities for further improvements.

In Chapter 6, the committee discusses the contributions and use of science

for CERP decision making. The chapter includes analysis of recent scientific advancements, current modeling, and the use of ecosystem services valuation for Everglades restoration. Current progress and challenges in adaptive management are also reviewed, along with evaluations of recent monitoring and assessment plan reports.

2

The Restoration Plan in Context

In this chapter, the stage is set for the committee's third biennial assessment of restoration progress in the South Florida ecosystem. Background is provided on the ecosystem decline, restoration goals, the needs of a restored ecosystem, and the specific activities of the restoration project. Important changes in the context for restoration, now 10 years after the Comprehensive Everglades Restoration Plan (CERP) was launched, are discussed with a specific focus on endangered species trends, water quality, and the human system. The watershed context is also discussed in considerable detail, because the system cannot be understood without that context. Canals, levees, and other water management structures have profoundly altered the hydrology, geomorphology, and connectivity of the system, and restoration of the ecosystem will require consideration of the ecosystem services (e.g., natural water storage, water quality treatment) once provided throughout the entire watershed.

THE SOUTH FLORIDA ECOSYSTEM'S ENVIRONMENTAL DECLINE

The Everglades once encompassed about 3 million acres of slow-moving water and associated biota that stretched from Lake Okeechobee in the north to Florida Bay in the south (Figures 1-1a and 2-1a). The nature of the water flow has characteristics that provide the functional basis of the Everglades, and as the flows have changed (Figure 2-1), the physical, chemical, and biological components of the Everglades ecosystems also have changed. In the following section the changes in the hydrologic and geomorphologic characteristics of water flows are explored in the watersheds of Central and South Florida.

Changes to the Kissimmee-Lake Okeechobee-Everglades Watershed

From the hydrologic perspective, the map of Central and South Florida is dominated by the 9,000 square mile Kissimmee-Okeechobee-Everglades water-

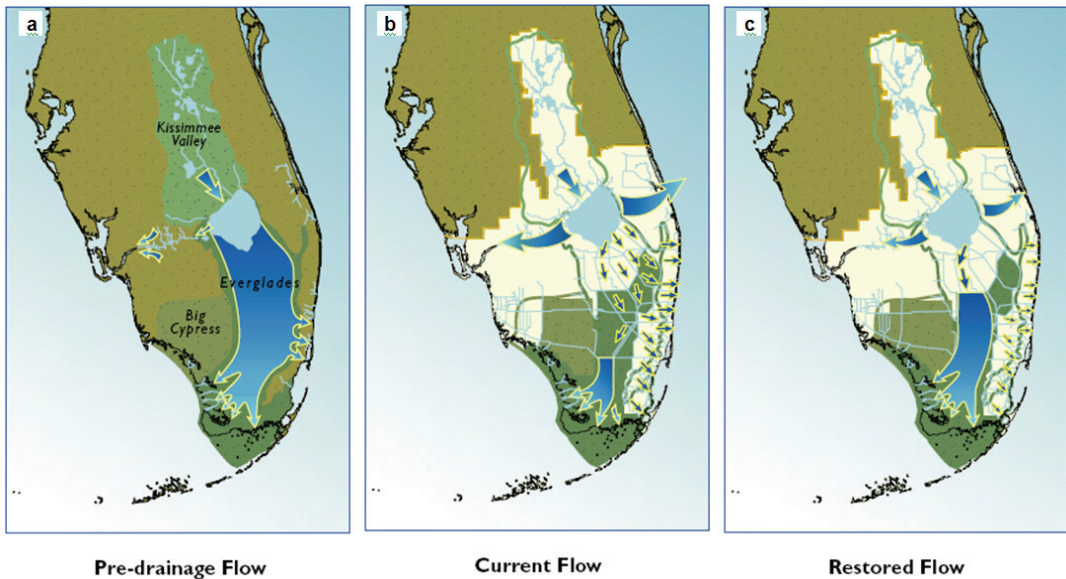

FIGURE 2-1 Water flow in the Everglades under (a) historical conditions, (b) current conditions, and (c) conditions envisioned upon completion of the Comprehensive Everglades Restoration Plan (CERP).

SOURCE: Graphics provided by USACE, Jacksonville District.

shed (Figure 2-2), a connected drainage basin that extends from the Orlando area 250 miles southward to Florida Bay (McPherson and Halley, 1996). The watershed includes three primary sub-basins: the Kissimmee River, Lake Okeechobee and its tributaries, and the Everglades. Prior to economic development and the creation of artificial drainage systems, water flowed from a series of small lakes at the northern end of this system through the Kissimmee River into Lake Okeechobee. During rainy periods, the lake spilled water southward over its low perimeter and into the Everglades, moving as a broad shallow sheet of water until it became more concentrated and flowed to tidewater through Shark River, Taylor, and Loxahatchee sloughs as well as through coastal rivers. Rainfall onto the 4,500 square mile Everglades augmented this overland flow and sustained it during dry periods.

The conversion of the uninhabited Everglades wilderness into an area of high agricultural productivity and cities was a dream of 19th-century investors, and, beginning in the early 1880s, water-control projects were built to drain the wetlands. By the end of the 20th century, the extensive water-control system to supply water to agricultural and urban areas and to provide flood protection to

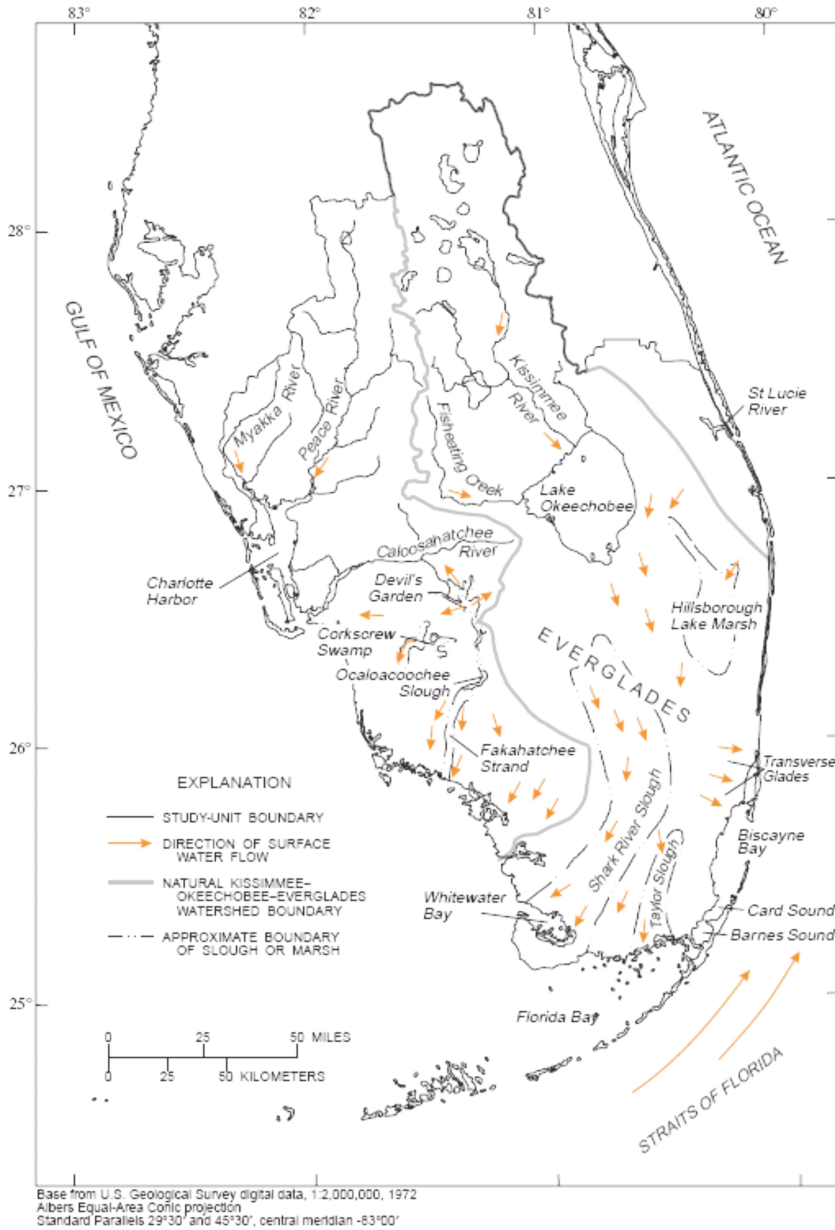

FIGURE 2-2 Pre-drainage water flows in the Kissimmee-Lake Okeechobee-Everglades watershed.

SOURCE: McPherson and Halley (1996).

developed areas included more than 2,600 miles of canals and levees, 64 major pumping stations, and about 1,300 control structures.¹ These installations, along with highway construction and urbanization, have dismembered the original flow paths of the Kissimmee-Lake Okeechobee-Everglades watershed (Figure 2-1).

Changes in the Kissimmee River Sub-Basin

Before the advent of drainage, canal, and levee projects that accompanied economic development, the far northern portion of the Kissimmee-Okeechobee-Everglades drainage basin was characterized by poorly connected lakes near the present location of Orlando. The Kissimmee River flowed southward from this lake district and emptied into Lake Okeechobee. In this pre-drainage period, the river was a highly sinuous, single-thread channel 90 miles long, with a flood plain 2 or more miles wide, and flanked by generally flat landscapes (McPherson and Halley, 1996). Under these geomorphic and hydrologic conditions, seasonal high flows and occasional large floods caused the river to overflow its banks, and periodically produced new channel locations. During these over-bank flow events, the flood plains stored considerable amounts of water, and they were directly connected in a hydrologic sense to the channel. Eventually, flows from the Kissimmee River Basin passed downstream into Lake Okeechobee and thence to the Everglades, so that even though the river was distant from the Everglades, it was an integral part of Everglades hydrology.

Early drainage projects begun between 1881 and 1894 affected the flow of water in the watershed north of Lake Okeechobee. By the late 1800s, more than 50,000 acres north and west of Lake Okeechobee had been drained and cleared for agriculture (Grunwald, 2006). As a flood control measure, the U.S. Army Corps of Engineers (USACE) began construction of the Kissimmee River Canal (C-38 Canal) in 1961, completing it 10 years later. What was once a 90-mile-long winding river was converted into a 52-mile-long, channelized conduit with a more direct route to Lake Okeechobee. The canal also included six locks and dams, a structural arrangement that introduced considerable hydrologic adjustments to the system. Over-bank flooding became very rare, and 40,000 to 50,000 acres of the flood plain were converted from wetlands to terrestrial habitats that became agricultural lands and pastures (McPherson and Halley, 1996).

These projects affected water quantity and water quality in Kissimmee River discharges. The loss of flood-plain space meant that the basin stored less water internally during high flows, the groundwater recharge was less, and the annual

¹See <http://www.sfwmd.gov/portal/page/portal/sfwmdmain/managing%20%20protecting%20water>.

total water yield of the river to Lake Okeechobee probably increased by about 20 percent or more (based on USACE and SFWMD, 1999). Because the naturally winding course of the river along with its associated oxbow lakes and wetlands were disconnected from the active river regime of the Kissimmee, their nutrient-filtering capabilities were lost. The loss of these filters and the increased nutrient loading that resulted from agricultural activities resulted in elevated deliveries of nutrients to Lake Okeechobee (Federico, 1982).

Changes in the Lake Okeechobee Sub-Basin

Prior to drainage and development, Lake Okeechobee was a primary connector and regulator in the Kissimmee-Okeechobee-Everglades hydrologic system (Steinman et al., 2002). The lake, bounded by low rises on all sides, probably had an average depth of about 20 feet during wet periods and extended to a surface area of more than 730 square miles (McPherson and Halley, 1996). The lake expanded laterally during rainy periods (sometimes as much as several miles) across gently sloping margins, particularly in the northwestern sector of the lake's edge. During dry periods the lake shrank into its basin, abandoning the low-gradient, marshy areas on its northwest perimeter; its general depth probably declined to about 16 feet. When the lake inflows exceeded its capacity, water overflowed the perimeter of the lake westward into marshlands of the Caloosahatchee River Basin and southward to the Everglades (see also Chapter 4 for a discussion of pre-drainage water budgets) (USACE and SFWMD, 1999).

In the late 1800s and early 1900s agricultural development slowly expanded farming areas around Lake Okeechobee and on lands south of the water body. Farmers found that during drought periods the lack of water crippled production, and in wet years floods were a major hazard. In response to major floods in 1903, the state created four canals to conduct excess water from Lake Okeechobee to the Atlantic Ocean, allowing managers to control water levels in the lake. The local drainage district constructed a sand and muck levee along 47 miles of the lake's perimeter. Devastating hurricanes in 1926 and 1928 stimulated construction of an additional canal (C-44) eastward to connect the lake to the St. Lucie Basin and enlargement of the connection (C-43) between the lake and the Caloosahatchee River to carry more lake water westward to the Gulf of Mexico. Today, large amounts of water are diverted from the original southward flow into the estuaries, altering salinity and nutrient loadings. During the 1930s the USACE raised the levee along the lake margin, cutting off the gently sloping terrain that once had been an overflow area. In the 1960s the USACE increased the height of the levee (now known as the Herbert Hoover Dike) to 30 feet. The total effect of the engineering works associated with Lake Okeechobee has been the fundamental alteration of the role of the lake in the Kissimmee-

Okeechobee-Everglades watershed (Lodge, 2005). The quantitative impacts of these changes are discussed in more detail in Chapter 4 (see also Figures 4-1 and 4-2). Understanding the flow of water in the Lake Okeechobee sub-basin is essential to understanding the movement and storage of nutrients in the sub-basin and the tremendous water quality challenges in Lake Okeechobee, as explored more fully in Chapter 5 and in NRC (2008).

Changes in the Everglades Sub-Basin

Prior to drainage and development projects, the Everglades portion of the Kissimmee-Okeechobee-Everglades drainage basin was a broadly defined zone of flowing water starting at Lake Okeechobee and ending in Florida Bay, bounded on the west by higher terrain in the Big Cypress Swamp and on the east by the sandy rises of the Atlantic Ridge (McPherson and Halley, 1996). The topographic gradient through the Everglades is only about 2 inches per mile, so that the flow of water was only 100 feet per day. The form of the flow was in broad sheets a few inches to a few feet deep. In 1848 Buckingham Smith (quoted in Fling et al., 2009) observed: “The water is pure and limpid and almost imperceptibly moves, not in partial currents, but, as it seems, in a mass, silently and slowly to the southward.” Well-defined sloughs, where water flowed during all but the driest years, provided important habitat and foraging sites for wading birds. The “river of grass” shaped the characteristic features of the landscape in a delicate balance between form and process. Field maps of the elongated tree islands that rise above the sawgrass suggest that the orientation of sloughs, ridges, and tree islands are all connected to the dominant flow direction (Parker et al., 1955; Sklar and van der Valk, 2002).

The construction of canals, levees, and dikes beginning in the early 20th century partitioned the Everglades portion of the Kissimmee-Okeechobee-Everglades watershed into discrete, poorly integrated units (Figure 2-1b). In 1907 Governor Napoleon Bonaparte Broward created the Everglades Drainage District to construct a vast array of ditches, canals, dikes, and “improved” channels. By the 1930s, 440 miles of other canals altered the hydrology of the Everglades (Blake, 1980). After extensive flooding in 1947 and increasing demands for improved agricultural production and flood control for the expanding population centers on the southeast Florida coast, the U.S. Congress authorized the Central and South Florida (C&SF) Project, an extensive, extremely sophisticated water management system. The C&SF Project provided flood control with the construction of a levee along the eastern boundary of the Everglades to prevent flows into the southeastern urban areas, established the 700,000 acre Everglades Agricultural Area (EAA) south of Lake Okeechobee (see Box 2-1), and created a series of water conservation areas (WCAs) to regulate water levels in devel-

BOX 2-1
The Everglades Agricultural Area

Making the land in the Everglades Agricultural Area (EAA) (see Figure 1-3) suitable for agriculture was one of the original primary objectives of the Central and South Florida (C&SF) Project (Lodge, 2005). Preliminary assessments in the late 1940s identified the peat soils just south of the southern rim of Lake Okeechobee as ideal for agriculture (Jones, 1948). Between 1950 and 1973, the USACE constructed a major dike on the east side of the agricultural area, established water delivery and drainage canals, and added pumps and control gates to manage water for agriculture. It also created the water conservation areas (WCAs) as temporary holding ponds that could accept surplus water during wet periods and provide additional water for agriculture during dry periods. Lake Okeechobee could also be managed to supply water in dry periods and accept excess water in wet periods. All of the EAA was designed for agricultural production, except for two fairly small wildlife management areas (WMAs): Rotenberger WMA and Holey Land WMA (Lodge, 2005). When the EAA was complete in the early 1970s, it subsumed 27 percent of the pre-drainage Everglades. In comparison, the WCAs occupy 37 percent, and Everglades National Park covers about 20 percent (Lodge, 2005; Secretary of Interior, 1994). As of the mid-2000s, the overwhelmingly dominant land use in the EAA is sugar production, with less than 1 percent used for pasture (R. Budell, Florida Agriculture and Consumer Services, personal communication, 2010).

oped areas in the remaining space between the lake and Everglades National Park (Light and Dineen, 1994). By protecting urban and agricultural lands in South Florida from floods and droughts (see Box 2-2), the project facilitated the prosperous economic development in the region, but it dramatically altered the Everglades ecosystem.

Ecological Implications of Watershed Changes

The profound hydrologic alterations were accompanied by many changes in the biotic communities in the ecosystem, including reductions and changes in the composition, distribution, and abundance of the populations of wading birds, the most visible component of the Everglades biota and symbolic to many stakeholders of the status of the entire ecosystem. Urban and agricultural development have reduced the Everglades to about one-half its pre-drainage size (Davis and Ogden, 1994; Figure 1-1b) and have contaminated its waters with phosphorus, nitrogen, sulfate, mercury, and pesticides. Today, the federal government has listed 67 plant and animal species in South Florida as threatened or endangered, with many more included on state lists. Some distinctive Everglades habitats, such as custard-apple forests and peripheral wet prairie, have

BOX 2-2
Climate Conditions in South Florida

Water management for both human and natural systems occurs within a context of high variation and frequent extremes in climate conditions. South Florida has a humid subtropical to tropical climate, and high annual precipitation (47 to 62 inches on average for Everglades weather stations). Rainfall occurs on 70 to 80 days per year, but often with high intensity. About 60-65 percent of the rainfall occurs during the summer wet season and is associated with thunderstorms. The central portion of the state experiences about 85 thunderstorms per year. Another notable feature of the precipitation regime in Florida is the frequency of torrential rain (over 3 inches within 24 hours). Precipitation variability between years is also very high; total rainfall amounts have ranged from 34 to 88 inches, with ranges of less than 40 to approximately 80 inches within most decades since 1890. Another characteristic of South Florida's climate is the frequency of tropical storms and hurricanes. In most years, at least one tropical storm or hurricane affects the region, with the maximum on record being 21 such storms in one year (1933).

Although the total amounts of rainfall inputs are large, the high temperature regime results in high evapotranspiration, so that possibility of drought is always present. Droughts generally follow low precipitation inputs during the wet season, but, as with other components of the South Florida climate system, there is great variability in the location, frequency, and duration of droughts. These characteristics imply that the high variability in precipitation inputs coupled with constant high evaporative demand result in both frequent excesses of water that must be managed to prevent urban and agricultural flooding and also deficits of water that require drought management, with a high potential for years of high precipitation to alternate with drought stresses (Duever et al., 1994). See also <http://www.ncdc.noaa.gov/oa/ncdc.html> for additional information on the climate of Florida.

disappeared altogether, while other habitats are severely reduced in area (Davis and Ogden, 1994; Marshall et al., 2004). Mercury contamination led the state of Florida to restrict consumption of nine species of fish in roughly 2 million acres of the Everglades (Scheidt and Kalla, 2007). Phosphorus from agricultural runoff has impaired water quality in large portions of the Everglades and has been particularly problematic in Lake Okeechobee (Flaig and Reddy, 1995). The Caloosahatchee and St. Lucie estuaries, including parts of the Indian River Lagoon, have been greatly altered by high and extremely variable freshwater discharges that bring nitrogen, phosphorus, and contaminants into the estuaries and alter the salinities that control the abundance of estuarine organisms (Doering, 1996; Doering and Chamberlain, 1999).

At least as early as the 1920s, private citizens were calling attention to the degradation of the Florida Everglades (Blake, 1980). However, by the time Marjory Stoneman Douglas's classic book *The Everglades: River of Grass* was published in 1947 (the same year that Everglades National Park was dedicated),

the South Florida ecosystem had already been altered extensively. Prompted by concerns about deteriorating conditions in Everglades National Park and other parts of the South Florida ecosystem, the public, as well as the federal and state governments, directed increasing attention to the adverse ecological effects of the flood-control and irrigation projects beginning in the 1970s (Kiker et al., 2001; Perry, 2004). By the late 1980s it was clear that various minor corrective measures undertaken to remedy the situation were insufficient. As a result, a powerful political consensus developed among federal agencies, state agencies and commissions, Native American tribes, county governments, and conservation organizations that a large restoration effort was needed in the Everglades (Kiker et al., 2001). This recognition culminated in the CERP, which builds on other ongoing restoration activities of the state and federal governments to create one of the most ambitious and extensive restoration efforts in the nation's history (see Appendix B for a timeline of significant events in South Florida ecosystem management).

SOUTH FLORIDA ECOSYSTEM RESTORATION GOALS

Several goals have been articulated for the restoration of the South Florida ecosystem, reflecting the various restoration programs. The South Florida Ecosystem Restoration Task Force (Task Force), an intergovernmental body established to facilitate coordination in the restoration effort, has three broad strategic goals: (1) "get the water right," (2) "restore, preserve, and protect natural habitats and species," and (3) "foster compatibility of the built and natural systems" (SFERTF, 2000). These goals encompass, but are not limited to, the CERP. The Task Force works to coordinate and build consensus among the many non-CERP restoration initiatives that support these broad goals.

The goal of the CERP, as stated in the Water Resources Development Act of 2000 (WRDA 2000), is "restoration, preservation, and protection of the South Florida Ecosystem while providing for other water-related needs of the region, including water supply and flood protection." The Programmatic Regulations (33 CFR 385.3) that guide implementation of the CERP further clarify this goal by defining restoration as "the recovery and protection of the South Florida ecosystem so that it once again achieves and sustains the essential hydrological and biologic characteristics that defined the undisturbed South Florida ecosystem." These defining characteristics include a large-areal extent of interconnected wetlands, extremely low concentrations of nutrients in freshwater wetlands, sheet flow, healthy and productive estuaries, resilient plant communities, and an abundance of native wetland animals (DOI and USACE, 2005). Although development has permanently reduced the areal extent of the Everglades ecosystem, the CERP hopes to recover many of the Everglades' original characteristics and

natural ecosystem processes. At the same time, the CERP is charged to maintain current levels of flood protection (as of 2000) and provide for other water-related needs, including water supply, for a rapidly growing human population in South Florida (DOI and USACE, 2005).

Although the CERP contributes to each of the Task Force's three goals, it focuses primarily on restoring the hydrologic features of the undeveloped wetlands remaining in the South Florida ecosystem, on the assumption that improvements in ecological conditions will follow. Originally, "getting the water right" had four components—quality, quantity, timing, and distribution. However, the hydrologic properties of flow, encompassing the concepts of direction, velocity, and discharge, have been recognized as an important component of getting the water right that had previously been overlooked (NRC, 2003c; SCT, 2003). Understanding of the CERP hydrologic goals is derived from paleoecology research (e.g., Willard et al., 2001; Saunders et al., 2006; Bernhardt and Willard, 2009) and hydrologic models that simulate the pre-drainage hydrology, such as the Natural System Model (NSM; see Chapter 4 and Box 4-1). The water quality goals are outlined by the existing legal and regulatory framework (described in more detail in Chapter 5). Numerous studies have supported the general approach of hydrologic restoration to achieve ecological restoration (Davis and Ogden, 1994; NRC, 2005; SSG, 1993), although it is widely recognized that recovery of the native habitats and species in South Florida may require restoration efforts, such as controlling exotic species and reversing the decline in the spatial extent and compartmentalization of the natural landscape (SFERTF, 2000; SSG, 1993).

The goal of ecosystem restoration can seldom be the exact re-creation of some historical or preexisting state because physical conditions, driving forces, and boundary conditions usually have changed and are not fully recoverable. Rather, restoration occurs along a continuum from intensive deconstruction and ecosystem reconstruction efforts in heavily impacted areas to improving conditions in less modified ones (Hobbs and Norton, 1996). Implicit in the understanding of ecosystem restoration is the recognition that natural systems are self-designing and dynamic and, therefore, it is not possible to know in advance exactly what can or will be achieved. Thus, ecosystem restoration is an enterprise with some scientific uncertainty in methods or outcomes that requires continual testing of goals and assumptions and monitoring of progress (NRC, 2007). Moreover, large-scale restoration inevitably involves economic and ecological tradeoffs depending on which sites in the landscape and which attributes of the ecosystem are emphasized (e.g., remediation to reduce levels of hazardous substances, productivity, recovery of rare species). The issue of tradeoffs is a theme that runs through much of Chapters 4 and 5 of this report.

What Natural System Restoration Requires

Restoring the South Florida ecosystem to a desired ecological landscape requires reestablishment of the critical processes that sustained its historical functions. Although getting the water right is the oft-stated and immediate goal, the restoration will be recognized as successful if it restores the distinctive characteristics of the historical ecosystem to the remnant Everglades (DOI and USACE, 2005). Getting the water right is a means to an end, not the end in itself. The hydrologic and ecological characteristics of the historical Everglades serve as restoration goals for a functional (albeit reduced in size) Everglades ecosystem. The first Committee on Independent Scientific Review of Everglades Restoration Progress (CISRERP) review identified five critical components of Everglades restoration:

1. Enough water storage capacity combined with operations that allow for appropriate volumes of water to support healthy estuaries and the return of sheet flow through the Everglades ecosystem while meeting other demands for water;
2. Mechanisms for delivering and distributing the water to the natural system in a way that resembles historical flow patterns, affecting volume, depth, velocity, direction, distribution, and timing of flows;
3. Barriers to eastward seepage of water so that higher water levels can be maintained in parts of the Everglades ecosystem without compromising the current levels of flood protection of developed areas as required by the CERP;
4. Methods for securing water quality conditions compatible with restoration goals for a natural system that was inherently extremely nutrient poor, particularly with respect to phosphorus; and
5. Retention, improvement, and expansion of the full range of habitats by preventing further losses of critical wetland and estuarine habitats and by protecting lands that could usefully be part of the restored ecosystem.

If these five critical components of restoration are achieved and the difficult problems associated with other major ecosystem changes, such as invasive species and altered fire regimes, can be managed, then the basic physical, chemical, and biological processes that created the historical Everglades can once again work to create a functional mosaic of biotic communities that resemble the distinctive characteristics of the historical Everglades. Even if the restored ecosystem does not exactly replicate the historical ecosystem, or reach all of the biological, chemical, and physical targets, the reestablishment of natural processes and dynamics should result in a viable and valuable Everglades ecosystem. The central principle of ecosystem management is to provide for the natural processes that historically shaped an ecosystem, because ecosystems are

characterized by the processes that regulate them. If the conditions necessary for those processes to operate are met, recovery of species and communities is far more likely than if humans attempt to specify every constituent and element of the ecological system (NRC, 2007).

RESTORATION ACTIVITIES

Several restoration programs, including the largest of the initiatives, the CERP, are now ongoing. The CERP often builds upon non-CERP activities (also called “foundation projects”), many of which are essential to the effectiveness of the CERP. In the following section, a brief overview of the CERP and some of the major non-CERP activities are provided.

Comprehensive Everglades Restoration Plan

WRDA 2000 authorized the CERP as the framework for modifying the C&SF Project. Considered a blueprint for the restoration of the South Florida ecosystem, the CERP is led by two organizations with considerable expertise managing the water resources of South Florida—the USACE, which built most of the canals and levees throughout the region, and the South Florida Water Management District (SFWMD), the state agency with primary responsibility for operating and maintaining this complex water collection and distribution system.

In the CERP conceptual plan (USACE and SFWMD, 1999; also called the Yellow Book), major alterations to the C&SF Project are proposed in an effort to reverse decades of ecosystem decline. The Yellow Book includes roughly 50 major projects consisting of 68 project components to be constructed at a cost of approximately \$12.8 billion (estimated in 2008 dollars; SFERTF, 2009). Major components of the restoration plan focus on restoring the quantity, quality, timing, and distribution of water for the natural system (Figure 2-3). These major CERP components include the following:

- **Conventional surface-water storage reservoirs**, which will be located north of Lake Okeechobee, in the St. Lucie and Caloosahatchee basins, in the EAA, and in Palm Beach, Broward, and Miami-Dade counties, will provide storage of approximately 1.5 million acre-feet.
- **Aquifer storage and recovery** is proposed as an approach to store water approximately 1,000 feet below ground using a large number of wells built around Lake Okeechobee, in Palm Beach County, and in the Caloosahatchee basin; the approach has not yet been tested at the scale proposed.
- **In-ground reservoirs** will store water in quarries created by rock mining.

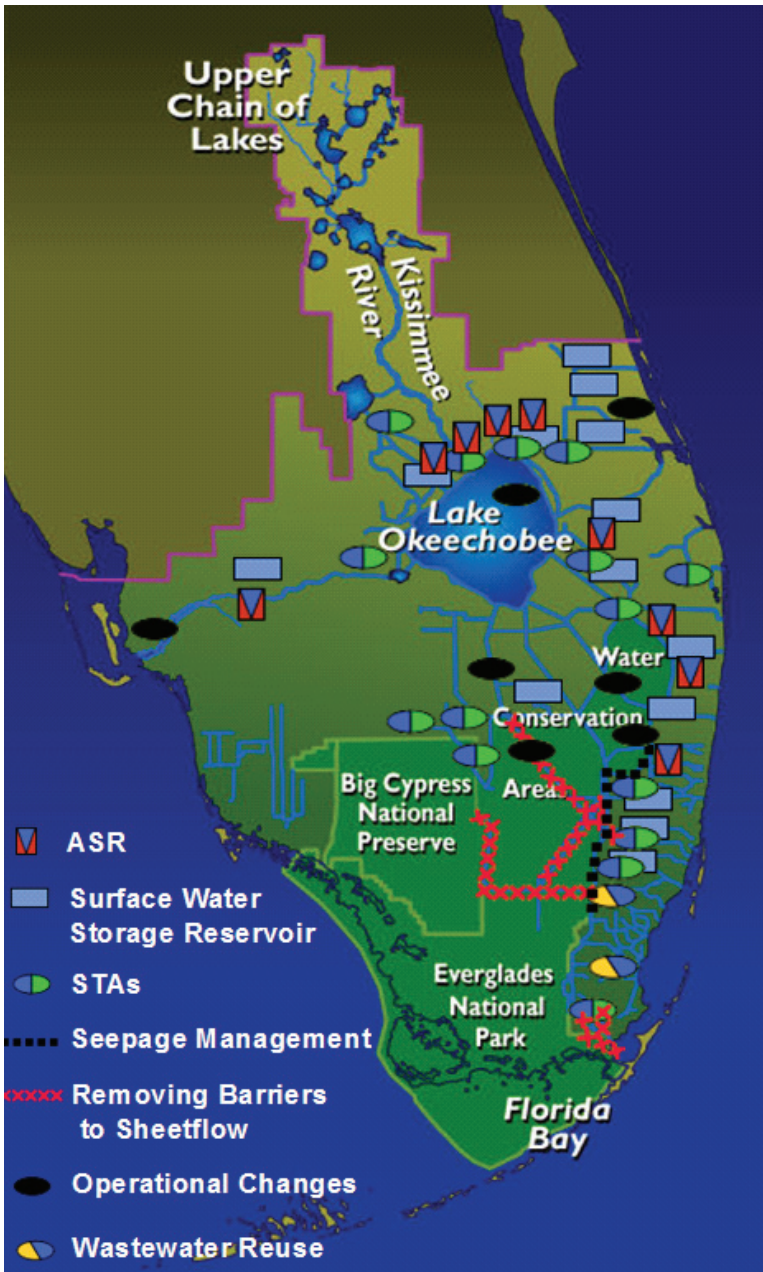

FIGURE 2-3 Major project components of the CERP.

SOURCE: Courtesy of Laura Mahoney, USACE.

- **Stormwater treatment areas (STAs)** are constructed wetlands that will treat agricultural and urban runoff water before it enters natural wetlands.²
- **Seepage management** approaches will prevent unwanted loss of water from the natural system through levees and groundwater flow; the approaches include adding impermeable barriers to the levees, installing pumps near levees to redirect lost water back into the Everglades, and holding water levels higher in undeveloped areas between the Everglades and the developed lands to the east.
- **Removing barriers to sheet flow**, including 240 miles of levees and canals, will reestablish shallow sheet flow of water through the Everglades ecosystem.
- **Rainfall-driven water management** will be created through operational changes in the water delivery schedules to the WCAs and Everglades National Park to mimic more natural patterns of water delivery and flow through the system.
- **Water reuse and conservation** strategies will build additional water supply in the region; two advanced wastewater treatment plants are proposed for Miami-Dade County in order to clean wastewater to a standard that would allow it to be discharged to wetlands along Biscayne Bay or to recharge the Biscayne aquifer.

The largest portion of the budget is devoted to storage and water conservation projects and to acquiring the lands needed for them (see NRC, 2005). Progress on the implementation of Everglades restoration projects is described in Chapter 3.

²Although some STAs are included among CERP projects, the USACE has recently clarified its policy on federal cost sharing for water quality features, indicating that cost-share for water quality features will be determined on a project-by-project basis. A memo from the Assistant Secretary of the Army (Civil Works) (USACE, 2007) states: "Before there can be a Federal interest to cost share a water quality improvement feature, the water must be in compliance with water quality standards for the current use of the affected water and the work proposed must be deemed essential to the Everglades restoration effort." The memo goes on to state, "The CERP Plan described in the 1999 Restudy reiterates these requirements and for plan formulation purposes assumes that programs, projects, and activities to achieve water quality standards would be in place and the standards met. Since the passage of the WRDA 1996 cost sharing provisions which were incorporated by reference in WRDA 2000, it has been explicitly stated and understood that any programs, projects, or activities required to achieve applicable water quality standards would be accomplished at 100 percent non-Federal cost." However, the memo goes on to state: "for CERP projects where inflows do not meet water quality standards the Corps will evaluate the benefits of any water quality features in Project Implementation Reports (PIRs) and if the benefits are determined to be essential to Everglades restoration, then the Corps may recommend to Congress in a PIR that it be given specific statutory authority to build and cost-share the subject water quality features to both help to achieve existing water quality requirements and provide additional restoration benefits critical to the successful implementation of CERP. . . . If Congress chooses to provide this authority such water quality features would be cost-shared accordingly as part of the Federal Project."

The modifications to the C&SF Project embodied in the CERP were originally expected to take more than three decades to complete, requiring a clear strategy for managing and coordinating restoration efforts. The Everglades Programmatic Regulations specifically require coordination with other agencies at all levels of government, although final responsibility ultimately rests with the USACE and SFWMD. WRDA 2000 endorses the use of an adaptive management framework for the restoration process, and the Programmatic Regulations formally establish an adaptive management program that will “assess responses of the South Florida ecosystem to implementation of the Plan; . . . [and] seek continuous improvement of the Plan based upon new information resulting from changed or unforeseen circumstances, new scientific and technical information, new or updated modeling; information developed through the assessment principles contained in the Plan; and future authorized changes to the Plan.” An interagency body called Restoration, Coordination, and Verification (RECOVER) has been established to ensure that sound science is used in the restoration (see Box 2-3). The RECOVER leadership group oversees the monitoring and assessment program that will evaluate the progress of the CERP toward restoring the natural system and will assess the need for changes to the plan through the adaptive management process.

In 2004, Florida launched Acceler8, a plan to hasten the pace of project implementation, and committed \$1.5 billion of its portion of the state-federal cost share for the CERP by 2010 for this initiative. The objectives of Acceler8 were to provide immediate environmental and water supply benefits and to serve as a foundation for subsequent restoration efforts by expediting 11 CERP project components and some non-CERP components. Although state budget pressures impacted the pace of the Acceler8 effort, numerous restoration projects continue to be expedited by the state of Florida. These projects are discussed in greater detail in Chapter 3.

Non-CERP Restoration Activities

When Congress authorized the CERP in WRDA 2000, the SFWMD, the USACE, the National Park Service (NPS), and the U.S. Fish and Wildlife Service (FWS) were already implementing several activities intended to restore key aspects of the Everglades ecosystem. These non-CERP initiatives are critical to the overall restoration progress. In fact, the effectiveness of the CERP was predicated upon the completion of many of these projects. These projects include Modified Water Deliveries to Everglades National Park (Mod Waters), C-111 South Dade, and the Critical Projects (see Box 2-4). Several additional projects are also either under way or in planning stages to meet the broad restoration goals for the South Florida ecosystem and associated legislative mandates. They include extensive water quality initiatives, such as the Everglades Construction

BOX 2-3 RECOVER

RECOVER (Restoration, Coordination, and Verification) is a multi-agency, multi-disciplinary team of scientists, modelers, planners, and resource specialists whose role is to organize, analyze, and apply scientific and technical information in support of the systemwide goals of the CERP.

Authorized in the CERP Programmatic Regulations (33 CFR 385.20), RECOVER provides essential support to the CERP toward meeting its goals and purposes while utilizing adaptive management principles. RECOVER's mission is accomplished through three kinds of activities:

- **Evaluation**—working with project development teams to evaluate and maximize the contribution made by each project to the systemwide performance of CERP;
- **Assessment**—measuring and interpreting actual responses in the natural and human systems as CERP projects are brought on line; and
- **Planning and Integration**—identifying potential improvements in the design and operation of the CERP, consistent with plan objectives, and striving for consensus among agencies regarding scientific and technical aspects of the restoration plan.

Specific tasks to be carried out by RECOVER include recommendation of interim goals and targets for the plan, development of performance measures, evaluations of systemwide impacts attributable to specific projects, evaluation and integration of new scientific information, and development and implementation of a monitoring plan.

The RECOVER Leadership Group (RLG) is constituted in 33 CFR Section 385.20(d) (2) to “assist the program managers in coordinating and managing the activities of RECOVER, including the establishment of sub-teams and other entities, and in reporting the activities of RECOVER.” The RLG is composed of 12 agency representatives, as specified in the Programmatic Regulations, including the USACE (co-chair), SFWMD (co-chair), the U.S. Environmental Protection Agency, National Oceanic and Atmospheric Administration, U.S. Fish and Wildlife Service (FWS), U.S. Geological Survey, National Park Service (NPS), Miccosukee Tribe of Indians of Florida, Seminole Tribe of Florida, Florida Department of Agriculture and Consumer Services, Florida Department of Environmental Protection, and the Florida Fish and Wildlife Conservation Commission (FFWCC).

SOURCE: USACE and SFWMD (2007d).

Project, and programs to establish best management practices (BMPs) to decrease nutrient loading.

10 YEARS LATER: THE CHANGING ENVIRONMENTAL AND SOCIOECONOMIC CONTEXT FOR THE CERP

In this section the trends in selected environmental, socioeconomic, and biological factors in South Florida are briefly summarized for the past decade since

BOX 2-4

Non-CERP Restoration Activities in South Florida

The following represent the major non-CERP initiatives currently under way in support of the South Florida ecosystem restoration (Figure 2-4). Progress on these non-CERP projects is discussed in Appendix C.

Kissimmee River Restoration Project

This project, authorized by Congress in 1992, aims to reestablish the historical river-floodplain system at the headwaters of the Everglades watershed and, thereby, restore biological diversity and functionality. The project plans to backfill 22 miles of the 56-mile C-38 Canal and restore 43 miles of meandering river channel in the Kissimmee River. The project includes a comprehensive evaluation program to track ecological responses to restoration. Completion is expected by 2013 (Jones et al., 2010).

Everglades Construction Project

The Everglades Forever Act (F.S. 373.4592; see Appendix B) required the state of Florida to construct stormwater treatment areas (STAs) to reduce the loading of phosphorus into the Arthur R. Marshall Loxahatchee National Wildlife Refuge, the Water Conservation Areas (WCAs), and Everglades National Park. These STAs are part of the state's long-term plan for achieving water quality goals, including the total phosphorus criterion for the Everglades Protection Area of 10 parts per billion (ppb).^a See also Chapter 5.

Modifications to the C&SF: C-111 (South Dade) Project

This project is designed to improve hydrologic conditions in Taylor Slough and the Rocky Glades of the eastern panhandle of Everglades National Park and to increase freshwater flows to northeast Florida Bay, while maintaining flood protection for urban and agricultural development in south Miami-Dade County. The project plan includes a tieback levee with pumps to capture groundwater seepage to the east, detention areas to increase groundwater levels and thereby enhance flow into Everglades National Park, and backfilling or plugging several canals in the area. A Combined Structural and Operational Plan (CSOP) will integrate the goals of the Mod Waters and C-111 projects and protect the quality of water entering Everglades National Park (DOI and USACE, 2005).

Modified Water Deliveries to Everglades National Park Project (Mod Waters)

This federally funded project, authorized in 1989, is designed to restore more natural hydrologic conditions in Everglades National Park. The project includes levee modifications and installation of a seepage control pump to increase water flow into WCA-3B and northeastern portions of Everglades National Park. It also includes providing flood mitigation to about 60 percent of the 8.5 square mile area (a low-lying but partially developed area on the northeast corner of Everglades National Park) and raising portions of Tamiami Trail. Mod Waters is a prerequisite for the first phase of "decompartmentalization" (i.e., removing some barriers to sheet flow), which is part of the CERP^b (DOI and USACE, 2005; NRC, 2008).

continued

BOX 2-4 Continued***Northern Everglades and Estuaries Protection Program***

In 2007, the Florida legislature expanded the Lake Okeechobee Protection Act (LOPA) to include protection and restoration of the Lake Okeechobee watershed and the Caloosahatchee and St. Lucie estuaries. The legislation, being implemented as the Northern Everglades and Estuaries Protection Program, will focus resources on restoration efforts for Lake Okeechobee and the Caloosahatchee and St. Lucie estuaries. The Lake Okeechobee Watershed Construction Project Phase II Technical Plan, issued in February 2008 in accordance with LOPA, consolidated the numerous initiatives already under way through Florida's Lake Okeechobee Protection Plan (LOPP) and Lake Okeechobee and Estuary Recovery (LOER) Plan.

Critical Projects

Congress gave programmatic authority for the Everglades and South Florida Ecosystem Restoration Critical Projects in Water Resources Development Act (WRDA) 1996, with modification in WRDA 1999 and WRDA 2007. These were small projects that could be quickly implemented to provide immediate and substantial restoration benefits such as improved quality of water discharged into WCA-3A and Lake Okeechobee and more natural water flows to estuaries. Examples of the Critical Projects include the Florida Keys Carrying Capacity Study, Lake Okeechobee Water Retention and Phosphorus Removal, Seminole Big Cypress Reservation Water Conservation Plan, Tamiami Trail Culverts, Ten Mile Creek Water Preserve Area, and the Lake Trafford Restoration (DOI and USACE, 2005).^c See also Appendix C.

^aSee <http://www.sfwmd.gov/org/erd/longtermplan/index.shtml>.

^bSee <http://www.saj.usace.army.mil/dp/mwdenp-c111/index.htm> for more information on Mod Waters and the C-111 Project.

^cSee <http://www.saj.usace.army.mil/projects> for more information on and the status of the Critical Projects.

the CERP was launched in WRDA 2000 to provide readers a better understanding of the changing context for the CERP. The level of environmental monitoring in South Florida is as high as or higher than anywhere in the United States, making it possible to gain a synoptic view of some key physical and biological features of the ecosystem. The record since 2000 documents South Florida's high inter-annual and multi-year environmental and socioeconomic variability, and underscores the looming challenge of identifying systematic trends in conditions related to restoration efforts. The record also highlights the species-specific nature of responses to environmental fluctuations and the persistent challenge posed by invasive nonindigenous species.

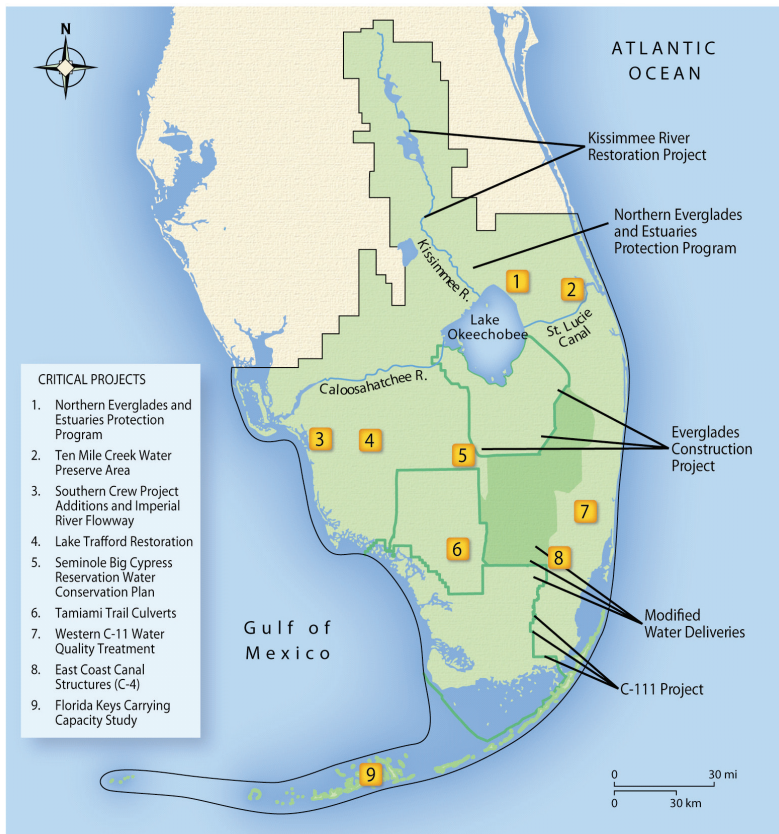

FIGURE 2-4 Locations of major non-CERP initiatives. © International Mapping Associates

Socioeconomic Setting

South Florida's growing human population places ever greater demands on both water management systems and ecosystems (NRC, 2008). Between 2000 and 2010 the human population in the five-county region of Broward, Martin, Miami-Dade, Monroe, and Palm Beach counties increased by more than 356,000 people, or 6.6 percent (Bureau of Economic and Business Research, 2005, 2009). However, the population in 2010 is substantially lower (by 467,000 people) than the estimate used by CERP planners to project future water demand in these counties (SFWMD, 2000, 2006b).

Water demand in the Lower East Coast Planning area increased from 889 million gallons per day (MGD) in 2000 to 904 MGD in 2005, and decreased to less than 800 MGD under the drought-related water restrictions in 2008. The Restudy projections of 2010 water demand in the Lower East Coast Service area ranged from 1,166 to 1,285 MGD and thus appear to be considerably higher than actual demand based on current population and water demand trends.

The socioeconomic impacts of the recent economic recession have been especially hard felt in Florida, where state population growth from April 2008 to April 2009 was negative (−1,845) for the first time in the state's history. Population decline was particularly marked in populous southeastern counties such as Broward (−13,904), Palm Beach (−8,033), and Miami-Dade (−5,485). With unemployment above 10 percent and construction of new homes stalled (12 percent of existing homes are in foreclosure), property values and prices of construction materials have decreased. The lower price of construction has reduced some restoration project costs. For example, the 2008 estimated cost of the 1-mile bridge was \$200 million, compared to the actual \$81 million contract awarded in 2009. Restoration efforts also benefited from the American Recovery and Reinvestment Act of 2009, which directed \$62 million toward South Florida ecosystem restoration projects. On the other hand, state revenues have been reduced for land acquisition and restoration. A prolonged economic recession could also potentially erode public support for environmental projects.

Despite the economic downturn, recreational use of the Everglades continues to be high and is apparently outpacing regional population growth. The number of visitors entering Everglades National Park through visitor gates has hovered around 1 million annually, but recreational boater use in the park has increased 2.5 times since the mid-1970s (Ault et al., 2008). Statewide levels of recreational fishing and wildlife watching increased significantly between 1996 and 2006 (Table 2-1), a trend that can be assumed to apply to the remnant Everglades ecosystem as well.

Hardly a week goes by without an article on Everglades restoration appearing in one of the major Florida newspapers. Nevertheless, there is mixed evidence for the level of public awareness and support of the CERP. A 2003 phone survey of 1,906 residents in southeast Florida estimated that 54 percent of the population was unaware of the CERP. On the other hand, nearly 90 percent of those who were aware of the CERP supported the project (Bransford et al., 2006). A 2009 poll of 600 Florida voters that was commissioned by the Everglades Foundation reported that 82 percent “strongly” or “somewhat strongly” supported restoration of the Everglades, mainly for water supply and flood control

TABLE 2-1 Summary of Hunting, Fishing, and Wildlife-Watching Activities and Related Expenditures (in 2010 dollars) in Florida since 1996

Activities		1996	2001	2006
Fishing	Anglers	2,900,000	3,100,000	3,700,000
	Fishing days	45,500,000	48,400,000	51,100,000
	Fishing expenditures	\$4,573,300,000	\$5,030,500,000	\$5,777,400,000
Hunting	Hunters	180,000	230,000	260,000
	Hunting days	4,400,000	4,700,000	3,800,000
	Expenditures	\$474,600,000	\$485,600,000	\$438,500,000
Wildlife watching	Participants	3,600,000	3,200,000	5,000,000
	Expenditures	\$2,332,200,000	\$1,940,900,000	\$4,041,900,000

NOTE: Expenditures adjusted for inflation to 2010 dollars. Numbers rounded to hundred thousands or two significant digits.

SOURCE: USFWS (1996, 2001, 2006).

benefits.³ Neither poll measured citizen willingness to pay for restoration, so it is hard to gauge the depth of public commitment.

Hydrologic Trends

In the past decade the Everglades experienced two severe droughts and associated large wildfires as well as 12 powerful tropical storms. These extremes in climate and weather played out against a steady rise in the sea level of nearly an inch.⁴

The region experienced severe droughts in 2000-2001 and 2006-2009. In terms of rainfall, more extreme droughts were recorded in the 1930s, 1940s, and 1980s, but the most recent droughts were accompanied by the worst water shortages in the region's history, as evidenced by record low water levels in Lake Okeechobee (Figure 2-5). Dry conditions in 2000-2001 and 2007-2008 promoted large wildfires, notably in the desiccated wetlands of northeast Shark River Slough (Figure 2-6). The 2006-2009 drought forced the SFWMD to impose new agricultural and urban water use restrictions that reduced potable water consumption by 105 million gallons between April 2007 and March 2008.

Since 1871 South Florida has experienced an average of three tropical systems (tropical storms or hurricanes) every four years. These systems exact a heavy toll on South Florida in terms of human lives and property losses. In the past decade the region experienced 12 tropical systems, notably Hurricanes Wilma, the third costliest hurricane in U.S. history (2005, \$20.6 billion), and

³See <http://www.evergladesfoundation.org/everglades-research-studies.php>.

⁴See http://www.nasa.gov/vision/earth/environment/sealevel_feature.html.

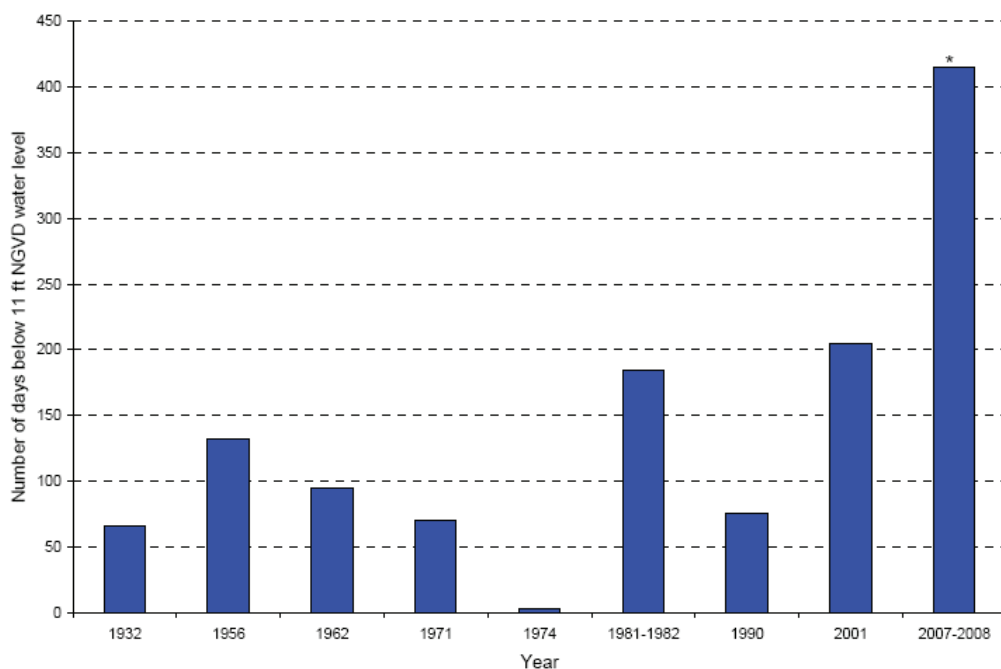

FIGURE 2-5 Number of days Lake Okeechobee water level was below 11 feet above sea level (National Geodetic Vertical Datum, NGVD) (ending date, April 30, 2008).

SOURCE: Abtew et al. (2009).

Frances (2004, \$8.9 billion), as well as Tropical Storm Fay (2008) (Blake et al., 2007; Abtew et al., 2010). Although destructive, these tropical systems figured importantly in the region's water supply. For example, Hurricane Gabrielle was pivotal in relieving the 2000–2001 drought, as was Tropical Storm Fay in relieving the 2006–2009 drought. The double-edged role of tropical storms in South Florida illustrates the complexity of managing water risks here and the multiple social benefits of added storage capacity in the system.

Trends in Exotic Species

South Florida ecosystems have been extensively invaded by exotic (non-native) plants and animals that pose a significant challenge and add costs and uncertainty to Everglades restoration. New species continue to be inadvertently or deliberately introduced, often as byproducts of the horticultural and pet trade

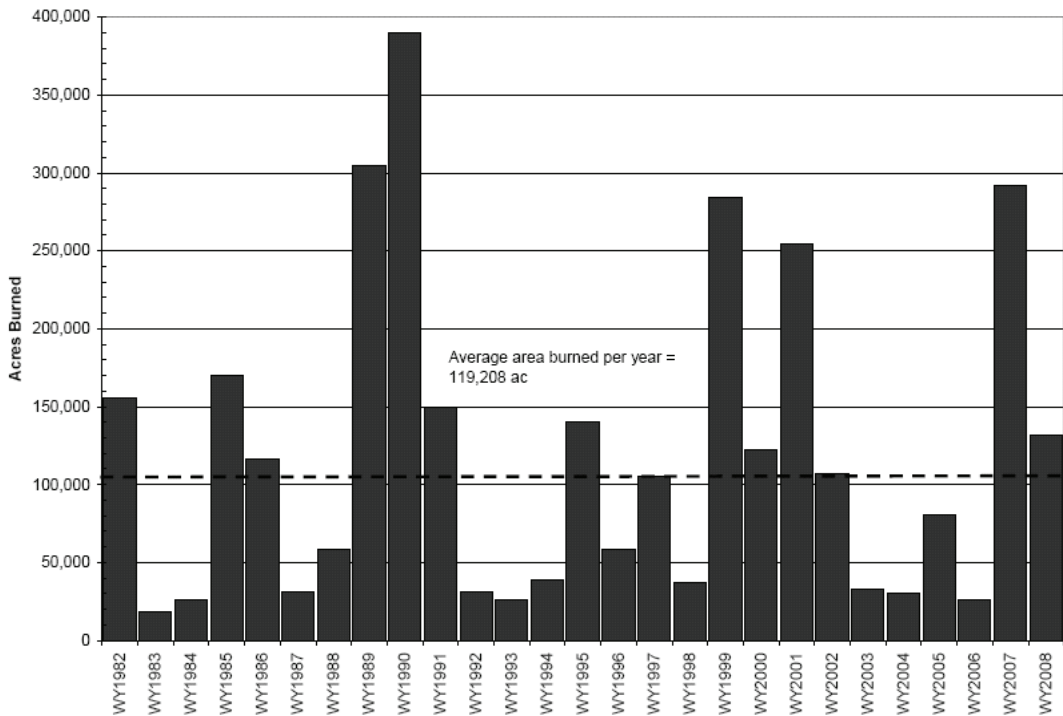

FIGURE 2-6 Number of acres burned per water year (WY, October to September) in the SFWMD area from wildfires that were 10 acres or larger (WY 1982-2009).

SOURCE: Abtew et al. (2010).

industries. RECOVER scientists list 50 exotic reptile and amphibian species, 13 birds, 17 mammals, 34 fish, and 69 invertebrates in the Greater Everglades (Rodgers et al., 2010). The Florida Exotic Pest Plant Council lists 61 invasive plants (from a total of 1,389 nonnative species) that are known to cause significant ecological impacts in South Florida.⁵ Some of these species have increased in extent to conditions that threaten native wetland species and communities, alter fire regimes, and impair infrastructure such as stormwater treatment areas and water conveyance systems.

Since 1980 state and federal agencies have spent more than \$300 million to control invasive plants in Florida, especially South Florida (Schmitz, 2007; Rodgers et al., 2010). Looking back over the past decade, the 2010 South Florida

⁵See <http://www.fleppc.org>.

Environmental Report (Rodgers et al., 2010) details not only an expanded effort to cope with exotic species threats to restoration, but also a greatly improved network of organizations and coordinated efforts to detect, monitor, and control these species. Efforts to control particular species and to improve the capacity to develop and release biological control agents for the most damaging species have in some cases met with dramatic success (Figure 2-7). Maintenance-level control of melaleuca (*Melaleuca quinquenervia*) has been achieved over large areas (albeit at a total cost of about \$40 million) and has resulted in initial recovery of native plant species in previously infested areas (Rayamajhi et al., 2009; Rodgers et al., 2010). Several other species, including both newly emerging threats (e.g., feathered waterfern [*Azolla pinnata*]) and long-established species (e.g., hydrilla [*Hydrilla verticillata*], torpedograss [*Panicum repens*]) are yielding to improved control efforts. On the other hand, 15 plant species are reported to be out of control and posing serious threats in at least some regions, and 7 species have been identified as emerging threats (Rodgers et al., 2010). Brazilian pepper (*Schinus terebinthifolius*) still occupies 700,000 acres of the region (Rodgers et al., 2010). Old World climbing fern (*Lygodium macrophyllum*, Figure 2-7) has expanded from 43,000 acres in 1999 to 160,000 acres in 2009 (Ferriter et al., 2002; Rodgers et al., 2010). Other species continue to emerge as potentially serious pests, for example, crested floatingheart (*Nymphoides cristata*), an aquatic plant from Asia, and downy rose Myrtle (*Rhodomyrtus tomentosa*), a fast-growing ornamental Asian shrub that is now widespread in South Florida.

Control of exotic invasive animals has long lagged behind the control of invasive plants (Ferriter et al., 2004) and still receives less effort than plant control. Since the Everglades Cooperative Invasive Species Management Area (E-CISMA)⁶ was established by the USACE, SFWMD, Florida Fish and Wildlife Conservation Commission (FFWCC), FWS, and NPS in 2003, it has coordinated the management of invasive species. Its publications describe the development of biological controls of various invasive plant species as well as descriptions of invasive animals. A few animal species, such as the African sacred ibis (*Threskiornis aethiopicus*), have been successfully eliminated, while reporting and rapid-response programs have been developed for species such as the African python (*Python sebae*) and the black and white tegu lizard (*Tupinambis merianae*), among others. However, exotic invasive animals, especially the many fish species, some of which are very abundant, are difficult to control. The prevention of invasion and the control of species that already have invaded are on the E-CISMA's agenda, but it is not clear that significant progress in controlling them is likely in the near future.

⁶See <http://www.evergladescisma.org/>.



FIGURE 2-7 (a) Old World climbing fern invasion and (b) defoliation at a release site for the brown lygodium moth.

SOURCE: Photos courtesy of P. Greb, U.S. Department of Agriculture, Agricultural Research Services (<http://www.invasive.org/weedcd/species/3046.htm>); SFWMD.

Threatened and Endangered Species

In 1998 the FWS published a programmatic biological opinion covering 18 federally listed species that could potentially be impacted by the CERP. Of the 12 animal species discussed there, the bald eagle (*Haliaeetus leucocephalus*) has recovered and been de-listed. In the most recent FWS five-year reviews published between 2007 and 2009, the West Indian manatee (*Trichechus manatus latirostris*) was classified as increasing (USFWS, 2007a), and the Florida panther (*Puma concolor coryi*) was characterized as stable in the short term but facing continuing threats (USFWS, 2009c). Five animal species were assessed as declining, including three species that primarily inhabit upland areas—the eastern indigo snake (*Drymarchon corais couperi*), Florida grasshopper sparrow (*Ammodramus savannarum floridanus*), and Florida scrub jay (*Aphelocoma*

coerulescens)—and two wetland species—the Everglades snail kite (*Rostrhamus sociabilis plumbeus*) and wood stork (*Mycteria americana*) (USFWS, 2007b,c,d, 2008a,b), although the wood stork population increased dramatically in South Florida during the 2008-2009 breeding season (Figure 2-8). Audubon’s crested caracara (*Polyborus plancus*), an upland hawk, was considered too poorly surveyed to assess trends (USFWS, 2009b). The Cape Sable seaside sparrow (*Ammodramus maritimus mirabilis*) appears stable (see below). In 2003 the smalltooth sawfish (*Pristis pectinata*), which occurs in tropical marine and estuarine areas in Florida from Charlotte Harbor to Florida Bay, was added to the Endangered Species list. Of the six plant species named in the 1998 biological opinion, only the status of two is known. The crenulated lead plant (*Amorpha crenulata*), a perennial, deciduous shrub that inhabits marl prairies and wet pine rocklands in a small area of Miami-Dade County, was considered stable (although only a few hundred individuals exist in the wild) (USFWS, 2007e). The Okeechobee gourd (*Cucurbita okeechobeensis* ssp. *okeechobeensis*), a vine that once was common in the flooded pond apple (*Annona glabra*) stands around Lake Okeechobee, is declining (USFWS, 2009d).

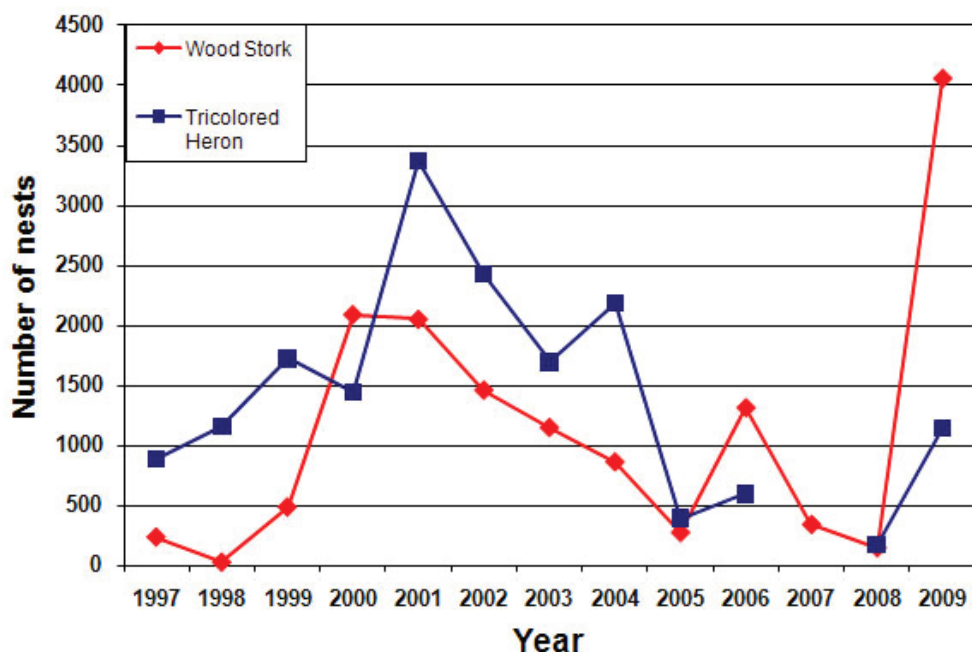

FIGURE 2-8 Trends in wood stork and tricolored heron nests in the Everglades since 1997.

SOURCE: Sklar et al. (2010).

Conflicts over endangered species have delayed CERP and related foundation projects such as Mod Waters (NRC, 2008; Rizzardi, 2001). Commencement of actual construction on projects such as the 1-mile bridge on the Tamiami Trail and the C-111 Spreader Canal (discussed in Chapter 3) will test the ability of various parties to cooperate in addressing multi-species recovery during CERP implementation. The issue of restoration planning for multiple endangered species is addressed further in Chapter 4.

Analysis of Trends of Endangered Birds

There are both hopeful signs of population recovery and ominous signs of extinction for the Florida Everglades' most threatened animals. The Everglades provides important nesting and foraging habitat for the endangered wood stork and other wading birds, the endangered Cape Sable seaside sparrow, and the endangered snail kite. In this section, the committee examines the trends and the drivers affecting these trends for these three endangered species.

Wood stork and wading bird numbers have generally increased throughout South Florida (Cook and Herring, 2007; Cook and Kobza, 2009) over the past decade, and 2009 was a record-setting year for nesting. More than 73,000 nests of wading birds were recorded in the Everglades, which represents the largest nesting effort in South Florida since the 1940s and an 83 percent increase over the average of the previous nine seasons. More than 60 percent of the nests were in WCA-3, and a large number of birds foraged there (Cook and Kobza, 2009). The wood stork produced more than 4,000 nests in 2009, double the average of the past decade. Such recovery was previously thought only to be possible with the implementation of CERP projects. Wading bird recovery was promoted by hydrologic conditions that increased food abundance and concentrated prey, including drought conditions (2006-2007) that reduced aquatic competitors and faster water-level recession rates without reversals (as described in Frederick and Ogden, 2001).

Cape Sable seaside sparrows appear to have stabilized in South Florida over the past decade after major water management changes starting in 2000 (for more discussion see Chapter 4 and Box 4-2), but there is little indication of recovery. Population size has been stable, fluctuating between 3,000 and 4,000 birds in Everglades National Park (J. Lockwood, Rutgers University, personal communication, 2010; D. Hallac, NPS, personal communication, 2009). Most individuals are in two subpopulations (B and E), which have remained stable and support 80-90 percent of the remaining individuals (SEI, 2007). Large declines in the proportion of area occupied by sparrows within their range that occurred across all the subpopulations between 1981 and 1992 also appear to have stabilized over the past decade (Cassey et al., 2007). Flooding and fire, which are

often considered the main threats to the survival of the Cape Sable seaside sparrow along with nest predation (Curnutt et al., 1998; Nott et al., 1998; Lockwood et al., 2006; Baiser and Lockwood, 2006), were less frequent over the past decade in sparrow habitats due in part to changes in the management in WCA-3A directly upstream from where sparrows nest in Everglades National Park.

In contrast, the snail kite population in Florida has plummeted over the past decade (Figure 2-9), and water levels in WCA-3A have been an important contributor (Cattau et al., 2008, 2009). The number of kites in Florida declined to 662 birds in 2009 from more than 3,500 individuals a decade earlier (Martin et al., 2007), making it once again one of the most endangered vertebrates in the continental United States. Kite numbers in Florida have not been so low since 1988 (Beissinger, 1995). Snail kites feed almost solely on snails of the genus *Pomacea* (Snyder and Snyder, 1969; Beissinger, 1990; Sykes et al., 1995). This high degree of diet specialization makes them dependent on flooded wetlands to feed and nest, and vulnerable to population declines if they are unable to find snails, such as during regional droughts (Beissinger, 1995). Although regional droughts contributed to the decrease in kite numbers in some recent years, lack of reproduction by kites primarily in WCA-3A and secondarily in Lake Okeechobee has played a major role (Cattau et al., 2008, 2009; Martin et al.,

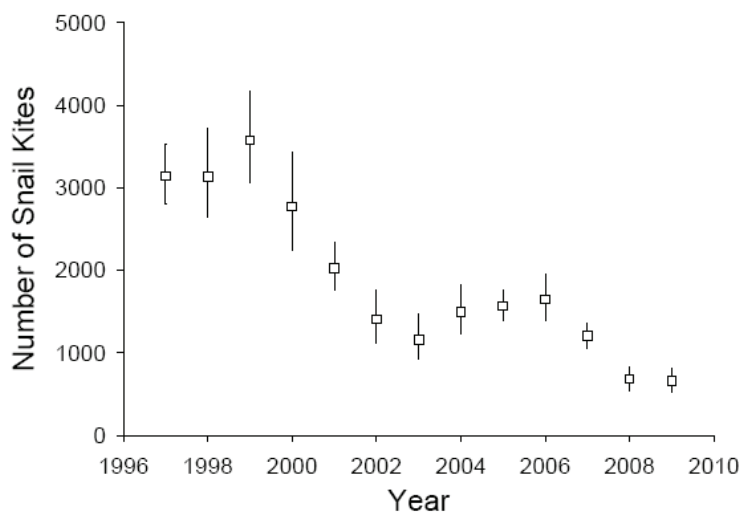

FIGURE 2-9 Annual estimates of snail kite population size in Florida and 95 percent confidence intervals.

SOURCE: Cattau et al. (2008, 2009).

2008). In 2009, 185 nests were recorded statewide but only 11 were in WCA-3A, producing only two young, which follows the trend of low reproduction from kites in WCA-3A since 2001. Southern WCA-3A had been the most important wetland for kite reproduction since the mid-1960s (Snyder et al., 1989; Cattau et al., 2009). The decline in kite use and nesting success in WCA-3A during the past decade coincides with changes in the regulation schedule in this wetland that were made to improve conditions in Everglades National Park for Cape Sable seaside sparrows (see Chapter 4).

In summary, there appear to be conflicting hydrologic habitat requirements for several of the most endangered species in the Everglades that are manifested by the current management of water in WCA-3. Water management changes over the past 10 years have stopped further declines in the sparrow population, but they have not been effective in producing the desired hydrologic conditions to recover this species. Meanwhile, the water management changes have contributed to decline of the snail kite reproduction in WCA-3A and to its statewide population crash. Yet, the same set of environmental conditions has resulted in wading bird recovery. These water management challenges are considered in more detail in Chapter 4.

Ridge and Slough Landscape Trends

The development of a water-control infrastructure for South Florida has resulted in widespread changes in ridge and slough landscapes. These distinctive landscapes consist of parallel ridges of peat and intervening water bodies (or sloughs) 100 to 500 feet wide with local relief of only about 1 foot and are broadly oriented along the local direction of water flow. These landscapes originally occupied nearly 4,000 square miles of South Florida, but they now cover only about half of their former extent. The landscapes degrade when canals and levees disrupt sheet flow, resulting in flattening of the landscape, loss of aquatic communities, and disorientation of the features (Figures 2-10 and 2-11). The ridge and slough system is also degraded by increased frequency of fires in areas with frequent drawdowns. In an early evaluation, the Science Coordination Team (SCT, 2003) concluded that “1) The Everglades ridge and slough landscape has changed and is continuing to change significantly, and 2) the landscape changes are having detrimental ecological effects on Everglades plants and animals.”

Recent changes in ridge and slough landscapes show a variety of trends, with increases in coverage of such landscapes in some places, declines in others, and substantial variability in trends in some places (Figure 2-12; Sklar et al., 2009b). The diagrams in Figure 2-12 represent historical trends in a metric of landscape patterning in three places in WCA-3A. The metric consists of a series of categories ranging from 1 (a landscape that is mostly similar throughout



FIGURE 2-10 Well-preserved ridge and slough landscape in the northern part of WCA-3, with sawgrass ridges appearing as dark green and lighter colored, water-filled sloughs.

SOURCE: Photo courtesy of C. McVoy, SFWMD.

its extent and that shows no directionality in its forms) to 6 (a landscape that has highly differentiated parts with strongly linear features). High values of this metric indicate a landscape that strongly exhibits the general characteristics of ridge and slough landscapes. Data for evaluating the metric are from areal photographic interpretation.

Example N5 in Figure 2-12 from the central part of WCA-3A has shown variable trends of change, first becoming more organized, then less organized, and finally more organized again. Example G3 from the southern WCA-3A has a different history, becoming more organized like typical ridge and slough landscapes, and then remaining unchanged for more than 30 years. Example I1 from the northern WCA-3A shows a steady decline in the landscape metric and has become progressively disorganized and less like a ridge and slough landscape. These representative examples show that recent trends in ridge and

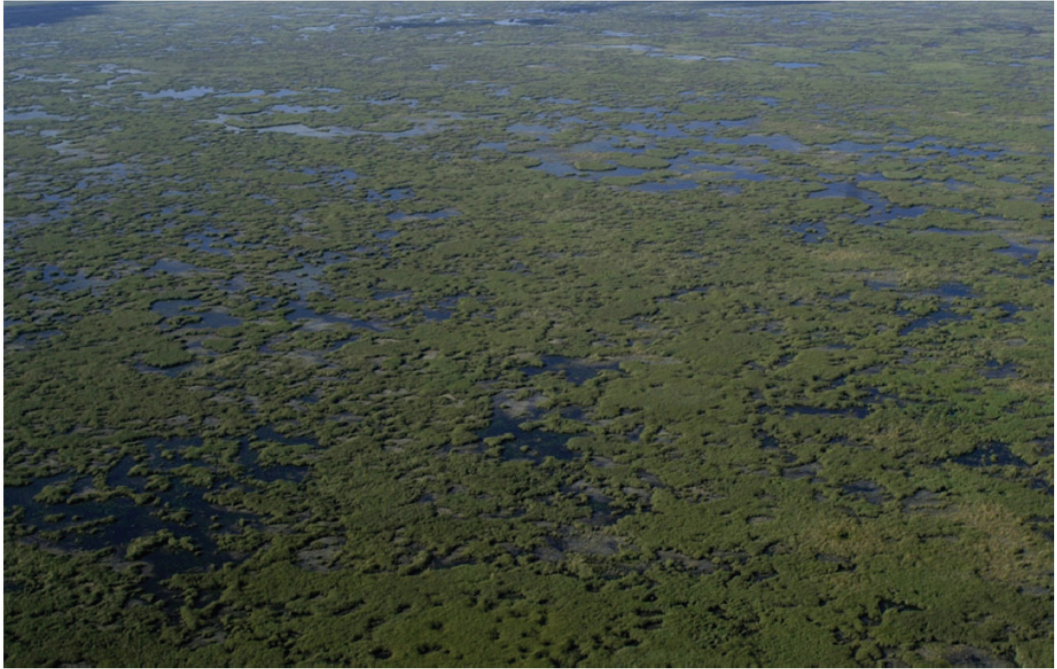

FIGURE 2-11 Degraded ridge and slough landscape in the northern portion of WCA-3A, showing sawgrass areas in dark green, with lighter water-filled basins. The landscape lacks a coherent directional pattern.

SOURCE: Photo courtesy of C. McVoy, SFWMD.

slough landscapes are variable according to location and can undergo significant degradation or enhancement on decadal timescales (Sklar et al., 2009b).

As outlined in NRC (2008), there have been drastic declines in the number of tree islands and the area of their coverage in the Everglades generally since the 1940s. The trends in tree island changes are best known for WCA-3A, where repetitive mapping using areal photography has revealed the changes. Specifically, tree island numbers and areal coverage in WCA-3A declined by about two-thirds between 1940 and 1970. Thereafter, the decline to 1995 was more gradual (see also Figure 4-10). Tree island declines in northern WCA-3A have generally been associated with lowered water levels, peat subsidence, and fires, while declines in southern WCA-3A have been more associated with persistent high water levels (see also Chapter 4).

Newly released data reveal that between 1995 and 2004 tree island numbers declined by about 18 percent and tree island areas by about 8 percent

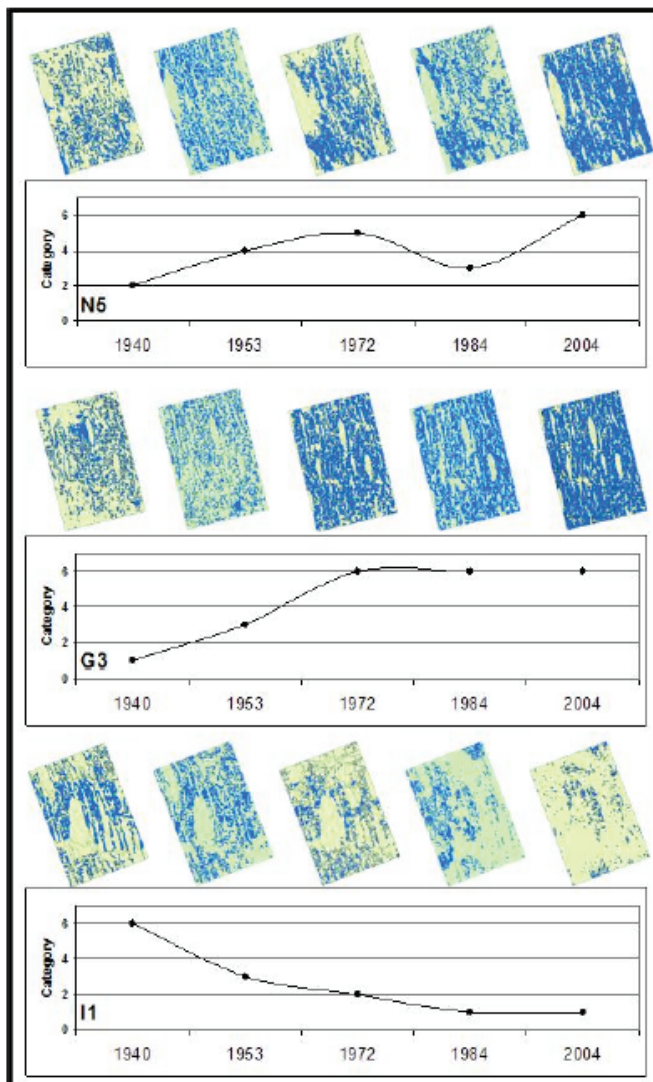

FIGURE 2-12 The historical changes in ridge and slough patterning are displayed for the years 1940, 1953, 1972, 1984, and 2004 for three study plots (labeled N5, G3, and I1) located in WCA-3A. The highest value (6) on the y-axis represents strong and linear landscape patterns. High values indicate a landscape that strongly exhibits the general characteristics of ridge and slough landscapes. Plot N5 is in central WCA-3B, adjacent to the L-67 levees; G3, lies in the southern portion of WCA-3; and I1 is located in the north central part of WCA-3A, north of Alligator Alley.

SOURCE: Sklar et al. (2009b).

(Figure 2-13). The largest areal declines occurred in southern WCA-3A near the L-67 levees followed by northwest WCA-3A. Tree islands in WCA-3B appear to have remained somewhat stable over this time period. The recent data show that the gradual decline of tree islands observed in the prior data has continued through 2004 (F. Sklar, SFWMD, personal communication, 2010).

Water Quality Trends

The CERP, as laid out in the Yellow Book (USACE and SFWMD, 1999), reflected an expectation that water quality concerns in the South Florida ecosystem could be adequately addressed by state efforts launched in the 1990s. Ten years later, water quality has emerged as a serious challenge that remains unresolved. Despite tremendous efforts by the state of Florida to control phosphorus through best management practices and STAs over the past 15 years (see Chapter 5 for more details), water quality trends show mixed responses. This section highlights data from two areas as examples of water quality trends over the past decade: Lake Okeechobee and the Everglades Protection Area (see Box 1-1).

In 2000, Florida enacted the Lake Okeechobee Protection Act (Chapter 00-103, Laws of Florida), which mandated a comprehensive plan to reduce phosphorus loading in the watershed to meet the total maximum daily load (TMDL) of 105 metric tons (mt) per year of surface-water inputs by 2015. Yet, 10 years later, the data show little if any evidence of improvement. Phosphorus loads, representing phosphorus concentration times volumetric discharge rate, fluctuate widely between wet and dry years, but despite implementation of best management practices north of the lake, the loads continue to be well above the goal except in the most severe drought years (Figure 2-14). Additionally, the average inflow phosphorus concentrations have generally remained unchanged (Figure 2-15). Meanwhile, phosphorus concentrations within Lake Okeechobee have risen steadily since the 1970s. A series of hurricanes that suspended phosphorus-laden sediments in the lake caused a sharp increase starting in 2005, and phosphorus concentrations have not yet returned to pre-hurricane levels (Figure 2-14; McCormick et al., 2010).

Water quality trends in the Everglades Protection Area over the last decade are mixed. Flow-weighted mean phosphorus concentrations in inflows to the WCAs have declined substantially from the baseline period 1979-1993 to the four-year period 2005-2009 (Payne et al., 2010b; Figure 2-16). Flow weighting serves to normalize the data to account for natural variations in wet and dry years so that trends become more apparent. The declining trends in the WCAs in Figure 2-16 can be assumed to reflect the role of the best management practices and STAs in dramatically decreasing overall phosphorus loads. However, Figure 2-16 also shows that the flow-weighted mean phosphorus concentrations

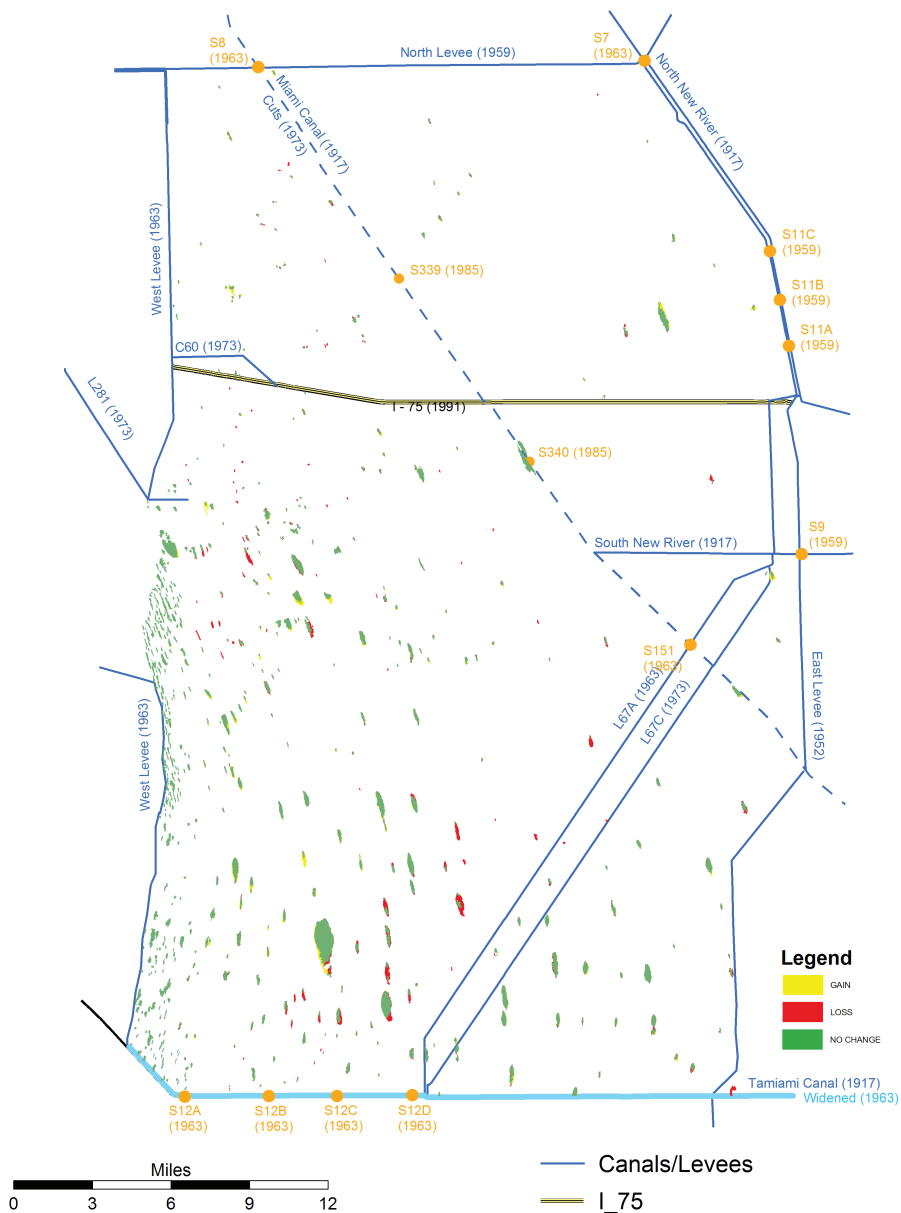

FIGURE 2-13 Changes in the areal extent of tree islands between 1995 and 2004. Yellow areas show where the islands have expanded, red areas show where they have lost their vegetation, and green areas are unchanged.

SOURCE: F. Sklar, SFWMD, personal communication, 2010.

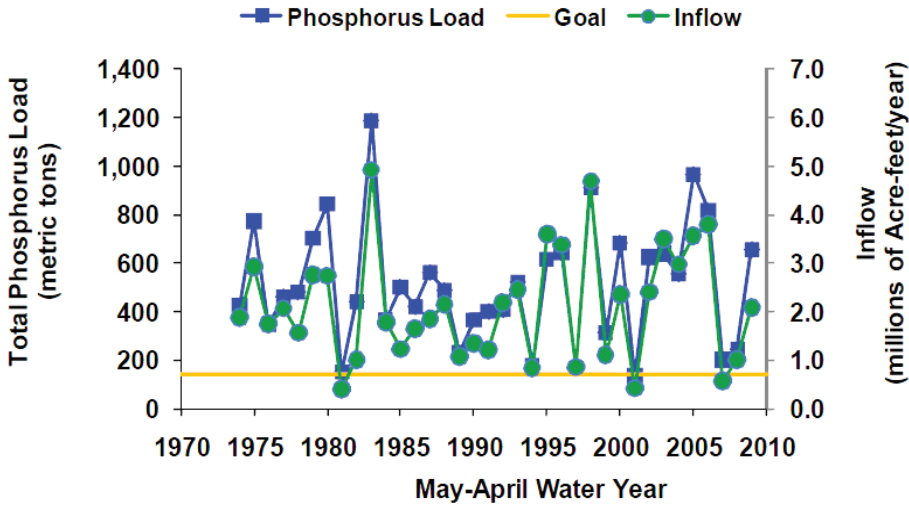

FIGURE 2-14 Calculated total phosphorus annual loads and annual water inflow volumes to Lake Okeechobee.

SOURCE: McCormick et al. (2010).

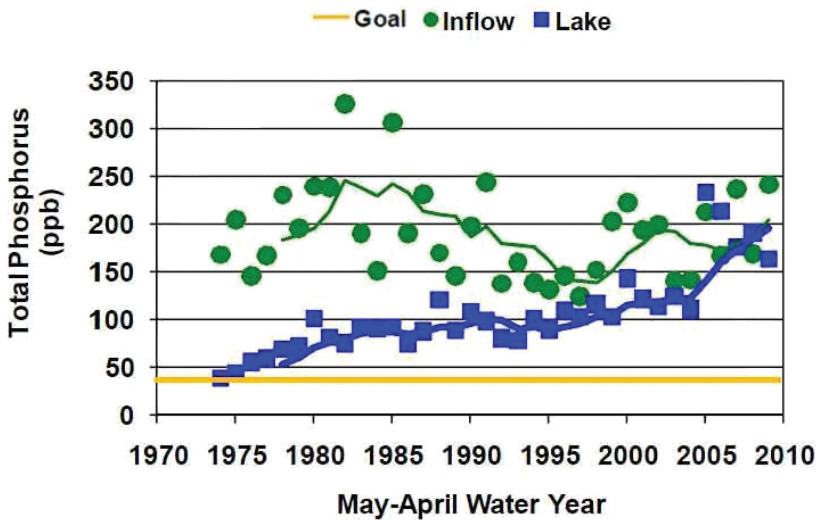

FIGURE 2-15 Inflow and average Lake Okeechobee total phosphorus concentrations, calculated from the Lake Okeechobee phosphorus budget, with five-year moving average trend lines.

SOURCE: Adapted from McCormick et al. (2010).

entering Everglades National Park have increased slightly in recent years. Geometric mean total phosphorus (TP) concentrations from the interior of all four regions of the Everglades Protection Area also show mixed trends (Figure 2-17), with increases in Loxahatchee National Wildlife Refuge (LNWR) and Everglades National Park in recent years (Payne et al., 2010b). Additionally, a phosphorus “exceedance” as defined as a violation of the Consent Decree has been reported in LNWR (SFWMD, 2009c; see also STAs in Chapter 3).

These data highlight the continuing water quality challenges facing the restoration program and the magnitude of the effort required to address it. Meanwhile, the Environmental Protection Agency has proposed new numeric nutrient criteria for the state of Florida (EPA, 2010) that could broaden the area within the South Florida ecosystem where water quality is under scrutiny. Water quality challenges are discussed in depth in Chapter 5.

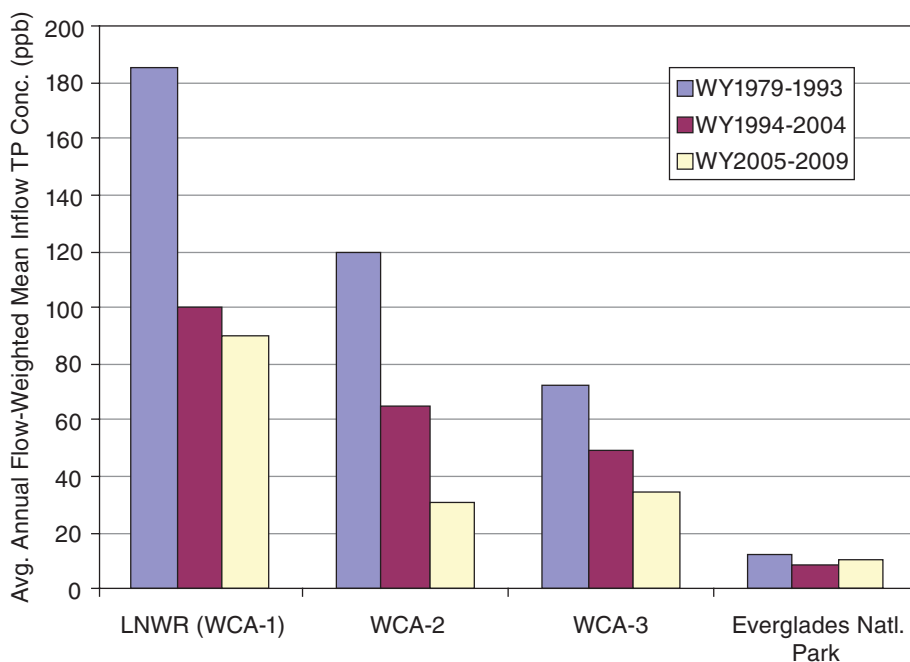

FIGURE 2-16 Annual average flow-weighted mean total phosphorus concentrations (in ppb) for inflow to the water conservation areas and Everglades National Park.

SOURCE: Data from Payne et al. (2010a).

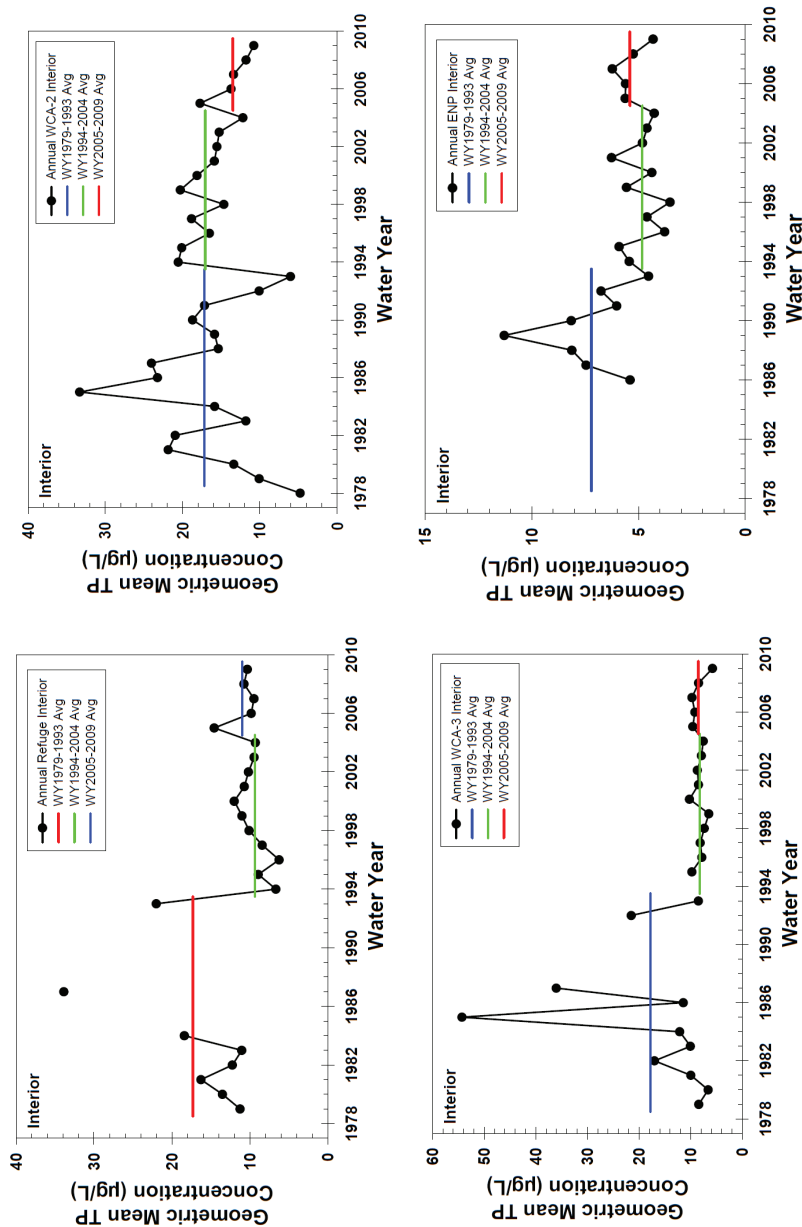

FIGURE 2-17 Annual geometric mean TP concentrations ($\mu\text{g/L}$ [or ppb]) for interior areas of the LNWR (WCA-1 or Refuge), WCA-2, WCA-3, and Everglades National Park (ENP) from WY1978-WY2009. The horizontal lines indicate the average geometric mean TP concentrations for the WY1979-WY1993, WY1994-WY2004, and WY2005-WY2009 periods. Note that unlike Figure 2-16, these data are not flow weighted.

SOURCE: Payne et al. (2010b).

Changes in CERP Since Its Authorization

When President Clinton signed the WRDA 2000 he authorized 68 projects extending over 30 years to restore the Everglades. The scope and ambition of the largest restoration plan in U.S. history was testimony to general public and political agreement that the Everglades system was in trouble and that it warranted federal (i.e., national) resources to effect its restoration. Disparate interest groups aligned to support the effort, convinced that the ecological and societal benefits of overhauling the Central and South Florida Project outweighed the high cost and large uncertainties.

As described in the most recent report of this committee (NRC, 2008), the first eight years after CERP authorization did not come close to expectations. At the federal level there was a sharp loss of political momentum and erosion of congressional support for Everglades restoration; the state of Florida assumed a disproportionate role in funding and moving preferred projects forward. At the same time, the translation of broad restoration goals into specific objectives and projects exposed the differences in priorities among interest groups, and projects grew increasingly susceptible to costly litigation. The cumbersome federal project planning and approval processes required to receive federal funding became painfully obvious. In short, restoration progress has been far slower than hoped for. Unfortunately, the ecosystem has continued to degrade, the estimated cost of restoration has increased to more than \$13 billion, and water supply and flood control challenges have only increased (NRC, 2008; SFERTF, 2009).

Nevertheless, many of the individuals who were important in launching the CERP in the late 1990s have continued to dedicate their careers to Everglades restoration. The pool of knowledgeable and experienced personnel has grown both deeper and broader. This expertise is critical in moving projects forward through complex state and federal political and procedural processes. The scientific and administrative capacity for implementing the CERP has grown stronger through time, and has benefited from truly excellent scientists in all aspects of Everglades science, both within CERP partner agencies and the scientific community at large. These scientists are continually working to advance the understanding of the condition and functioning of the South Florida ecosystem to further improve the restoration plan as it moves forward (see also Chapter 6). The strength of CERP planners, engineers, scientists, and managers is evident in the CERP progress described in the remainder of this report (particularly the implementation progress in Chapter 3).

CONCLUSIONS AND RECOMMENDATIONS

This review of the restoration plan and its context 10 years after the CERP was authorized reveals positive as well as negative trends. The South Florida

ecosystem has been fundamentally altered by human modifications of it and by population growth over the past 130 years, and achieving the goals of the ambitious restoration plan remains challenging. The scientific attention that has been brought to bear on the system is impressive and has produced powerful results. Some species, particularly wading birds, Cape Sable seaside sparrows, and panthers appear to be increasing or stable, while others, such as the snail kite, have declined perilously close to extinction. Invasive species continue to present major challenges, even as some of them are being well controlled. Managing water quality and providing the required storage for the restoration continue to be challenging.

This committee reaffirms its predecessor's conclusions (NRC, 2008) that the limited progress made to date, coupled with environmental and societal changes and continued declines of some aspects of the ecosystem, make accelerated progress in Everglades restoration even more important. Delays will continue to jeopardize the success of the restoration enterprise. The commitment to long-term scientific activities, including monitoring and assessment, remains essential. The following chapters address these matters in more detail.

3

Implementation Progress

This committee is charged with the task of discussing significant accomplishments of the restoration and assessing “the progress toward achieving the natural system restoration goals of the Comprehensive Everglades Restoration Plan (CERP)” (see Chapter 1). The last National Research Council (NRC) review of restoration progress (NRC, 2008) noted that in the first eight years after the Water Resources Development Act of 2000 (WRDA 2000) was authorized, the CERP had been bogged down in budgeting, planning, and procedural matters and was making only scant progress toward achieving restoration goals. Although some project phases were under way, most of the CERP accomplishments were programmatic (e.g., land acquisition, project implementation reports [PIRs]) and served to lay the foundation for later project construction (NRC, 2008).

In this chapter, the committee provides an update to the NRC’s previous assessments of CERP and related non-CERP project planning and implementation progress (NRC, 2007, 2008) as well as an analysis of any natural system benefits resulting from this progress to date. Also included are discussions of programmatic issues related to CERP progress, such as funding and project sequencing.

CERP RESTORATION IMPLEMENTATION

Progress restoring the South Florida ecosystem will come about only through implementation of restoration projects. The analysis of implementation progress provided in this section focuses on CERP projects, although many of these projects build upon restoration benefits provided by non-CERP projects, which are discussed in the next section. Additional detail on implementation progress can be found in Chapter 7 of the South Florida Environmental Report (Williams et al., 2010).

The Yellow Book (USACE and SFWMD, 1999) outlined a conceptual plan for 68 projects and identified a schedule for implementation. The originally ambitious timetable gave way to delays in project planning and lower-than-expected

program funding. As a result, the project implementation schedule has been extended and revised several times since the CERP was launched. (See NRC [2008] for additional discussion of major causes of CERP delays.) The committee's attempt to track early CERP project implementation is shown in Table 3-1, which represents a merger of the CERP projects within the most recent schedule, termed the Integrated Delivery Schedule (discussed in more detail later in this chapter), and the earliest projects (scheduled for completion by 2010) from the previous Master Implementation Sequencing Plan (MISP) (USACE and SFWMD, 2005a). The projects listed in Table 3-1 are also shown on a map of the South Florida ecosystem in Figure 3-1.

The task of tracking project progress and assessing delays over time is complex because some projects have been reorganized, transferred out of the CERP, or split into phases to achieve incremental restoration where feasible. However, the project status information (available at <http://www.evergladesplan.org>) has been significantly improved since the committee's last report. Project planning progress can now be tracked in a single color-coded spreadsheet,¹ and quarterly progress reports for multiple projects in a region can be viewed at one time.²

As of June 2010, four CERP restoration projects are actively under construction, and four pilot projects are in an installation and testing phase. Many more projects are in planning and design phases (see Table 3-1). Estimated project completion dates continue to be delayed, and not a single CERP project has been completed as of the production of this report.³ Nevertheless, considering the state of Florida's extreme budget challenges over the past two years, the project implementation schedule has remained more stable than might have been expected due to increased funding from the federal government for the Everglades restoration efforts, including assistance from the American Recovery and Reinvestment Act of 2009, also known as the economic stimulus. Funding is discussed in more detail later in this chapter. In the following sections the committee highlights CERP progress with a focus on progress in achieving natural system restoration benefits through incremental CERP project implementation and learning achieved through CERP pilot projects.

CERP Projects

In the past two years, the Everglades restoration has seen a resurgence of construction activity, thanks in part to a boost in federal funding and the

¹See http://www.evergladesplan.org/pm/projects/project_docs/status/csf_milestones_current.pdf.

²See http://www.evergladesplan.org/pm/projects/project_docs/status/central_current.pdf or http://www.evergladesplan.org/pm/projects/project_docs/status/south_current.pdf.

³One original CERP project, Acme Basin B, has been completed, but the project was expedited by the state of Florida and withdrawn from the CERP program.

TABLE 3-1 South Florida Ecosystem Restoration Project Status as of June 2010

Project or Component Name	Yellow Book (1999) Estimated Completion Date	MISP 1.0 (2005) Estimated Completion Date	2008 Estimated Completion Date (NRC, 2008)
PILOT PROJECTS			
C-43 ASR Pilot (Fig. 3-2, No. 1)	2002	2006	2012
Hillsboro ASR Pilot (Fig. 3-2, No. 2)	2002	2006	2009
Lake Okeechobee ASR Pilot (Includes Kissimmee River, Port Mayaca, and Moore Haven sites) (Fig. 3-2, No. 5)	2001	2007	2012
Regional ASR Study	NA	2010–2015	NA
L-31N (L-30) Seepage Management Pilot (Fig. 3-2, No. 4)	2002	2008	2010
Decomp Physical Model	NA	2010–2015	NA
C-111 Spreader Canal Design Test	NA	NA	NA
RESTORATION PROJECTS			
Melaleuca Eradication and Other Exotic Plants	2011	2007	2026
Winsberg Farm Wetlands Restoration (Fig. 3-2, No. 3)	2005	2008	2010
Biscayne Bay Coastal Wetlands (Phase 1) (Fig. 3-2, No. 6)	2018	2008	2011
Picayune Strand Restoration (Fig. 3-2, No. 7)	2005	2009	2015

IDS (March 2010) Estimated Construction Completion Date	Project Implementation Report (PIR) or Pilot Project Design Report (PPDR)	Authorization Status	Planning/ Design	Construction Status; Installation and Testing Status for Pilots
Not specified	PPDR Final Sept. 2004	Authorized in WRDA 2000	Completed	Suspended due to poor site conditions
Not specified (but estimated to be completed in 2011)	PPDR Final Sept. 2004	Authorized in WRDA 1999	Completed	Installed Sept. 2008; Testing ongoing
Not specified	PPDR Final Sept. 2004	Authorized in WRDA 1999	Completed	Installed 2008; Testing ongoing (Kissimmee River only)
Not specified 2012	NA PPDR Final May 2009	NA Authorized in WRDA 2000	NA Completed	Ongoing Not begun
2013	NA	Programmatic Authority WRDA 2000	Completed	Not begun
2011	NA	Programmatic Authority WRDA 2000	Completed	Ongoing
2011	Final June 2010	Programmatic Authority WRDA 2000	Ongoing	Start anticipated late 2010
Not specified	Draft Feb. 2008	NA	Suspended	Phase 1: Completed outside of CERP Phase 2: Not begun
2012	Draft March 2010	.	Completed	Ongoing; expedited by FL prior to authorization
Merritt: 2012 Faka-Union: 2012 Miller: 2018	Final, 2004; submitted to Congress Sept. 2005	Construction Authorized in WRDA 2007	Completed	Prairie Canal completed in 2007 (expedited by FL); Merritt ongoing

TABLE 3-1 Continued

Project or Component Name	Yellow Book (1999) Estimated Completion Date	MISP 1.0 (2005) Estimated Completion Date	2008 Estimated Completion Date (NRC, 2008)
Indian River Lagoon - South (Fig. 3-2, No. 8)			2023
- C-44 Reservoir*	2007	2009	2014
- Natural Areas Real Estate Acquisition	Not specified	2009	Not specified
Broward County WPAs			
- C-9 Impoundment* (Fig. 3-2, No. 9)	2007	2009	2014
- Western C-11 Diversion Impoundment* (Fig. 3-2, No. 10)	2008	2009	2014
- WCA 3A & 3B Levee See page Management* (Fig. 3-2, No. 9,10)	2008	2008	2017
Acme Basin B Discharge (Fig. 3-1, No. 11)	2006	2007	2009
Site 1 Impoundment* (Fig. 3-2, No. 2)	2007	2009	2013
C-111 Spreader Canal* (Fig. 3-2, No. 12)	2008	2008	
Western Project (PIR#1)			2011
Eastern Project (PIR#2)			TBD
North Palm Beach County – Part 1	Not specified		
- C-51 and Loxahatchee (L-8 Basin) Reservoir (Fig. 3-2, No. 13)	2011	2008	2008
Everglades Agricultural Area Storage Reservoir, Part 1, Phase 1* (Fig. 3-2, No. 14)	2009	2009	TBD

IDS (March 2010) Estimated Construction Completion Date	Project Implementation Report (PIR) or Pilot Project Design Report (PPDR)	Authorization Status	Planning/ Design	Construction Status; Installation and Testing Status for Pilots
Not specified	Final 2004; submitted to Congress Aug. 2004	Construction Authorized in WRDA 2007	Completed by state; ongoing by USACE	Not begun
2015			NA	NA
Not specified				
	Final April 2007			
2019			Ongoing	Not begun
2015			Ongoing	Not begun
2023			Ongoing	Not begun
NA	Discontinued ^a	NA	Completed	Completed outside of CERP
2014	Final 2006; submitted to Congress Dec. 2006	Construction Authorized in WRDA 2007	Ongoing	Not begun
2012	Final Dec. 2009		Completed	Ongoing; expedited by FL prior to authorization
Not specified	Not begun		Not begun	Not begun
Not specified	In development		Ongoing	
Not specified			Ongoing	Expedited by FL prior to authorization; on hold pending funding
TBD	Revised Draft (2006) further revisions on hold ^b		Completed	Construction suspended ^b

TABLE 3-1 Continued

Project or Component Name	Yellow Book (1999) Estimated Completion Date	MISP 1.0 (2005) Estimated Completion Date	2008 Estimated Completion Date (NRC, 2008)
Lake Okeechobee Watershed			2015
-Lakeside Ranch STA	2010	2010–2015	Not specified
- Lake Istokpoga Regulation Schedule* (Fig. 3-2, No. 15)	2001	2008	Not specified
Modify Rotenberger Wildlife Management Area Operation Plan (Fig. 3-2, No. 16)	Not specified	2009	2009
C-43 Basin Storage: West Basin Storage Reservoir (Fig. 3-2, No. 1)	2012	2010	2013
WCA 3 Decompartmentalization and Sheetflow Enhancement (Decomp)*		2020	
- Decomp Part 1	2010	2015–2020	2016
- Decomp Part 2	2010	2015–2020	2019
- Decomp Part 3	2019	2015–2020	Beyond 2020
ENP Seepage Management	2010	2010–2015	2016

NOTES: Projects in Table 3-1 reflect those that were included in MISP Band 1, those that are now identified in the Integrated Delivery Schedule (March 2010 version) for construction start prior to 2020, and other projects deemed by the committee to be relevant to near-term restoration progress. Gray shading of project names reflects projects being expedited and/or carried out entirely with state funding as of 2010. Gray shading of planning/design or construction cells indicates past or present aspects of projects that were expedited with state funding. In most cases, design and/or construction of these projects was moving forward prior to the finalization of the PIR. Some of these projects are still considered CERP components, while others are now considered outside of the CERP; NA = not applicable; TBD = to be determined

*Projects that were conditionally authorized in WRDA 2000, subject to approval of the PIR.

^aThe South Florida Water Management District (SFWMD) has decided to work with local interests to complete the design and construction of the Acme Basin B Discharge project and the Lakes Park Restoration project outside of the CERP. Cost sharing under the CERP is not anticipated; thus effort on these two PIRs has been discontinued, and CERP planning/design efforts have ended.

^bThe Everglades Agricultural Area (EAA) Storage Reservoir project is on hold, pending the resolution of planning for the acquisition of U.S. Sugar Corporation lands, although court cases (e.g., USA, et al. v. SFWMD, et al. 1:88-civ-01886-Moreno) may impact the plans for this project.

SOURCES: DOI and USACE (2005); USACE, 2009a; L. Gerry, SFWMD, personal communication (2010); E. Bush, USACE, personal communication (2010); D. Tipple, USACE, personal communication (2010); Project Status Reports from www.evergladesplan.org; USACE and SFWMD (1999).

IDS (March 2010) Estimated Construction Completion Date	Project Implementation Report (PIR) or Pilot Project Design Report (PPDR)	Authorization Status	Planning/ Design	Construction Status; Installation and Testing Status for Pilots
2023 2011	In development		Ongoing Ongoing	Ongoing; expedited by FL prior to authorization Ongoing (part of Lakeside Ranch project)
Not specified			Ongoing	
NA	NA	NA	Implement as needed	NA
2014 2019	Final 2009; approved by USACE Chief of Eng. in March 2010		Completed	Not begun
2016 2018 2019 2016	In development Not begun Not begun On hold—to resume 2013		Ongoing Not begun Not begun On hold pending pilot	Not begun Not begun Not begun Not begun

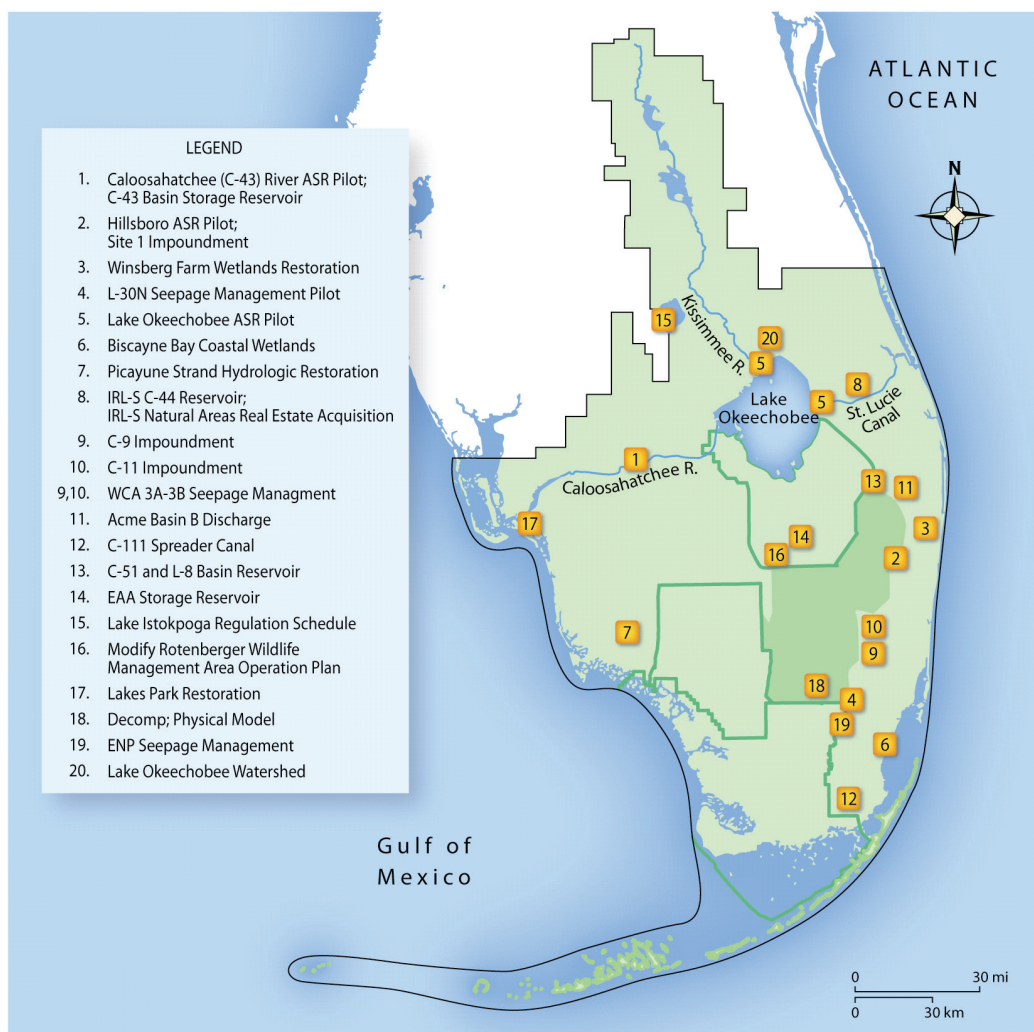

FIGURE 3-1 Locations of CERP projects and pilots listed in Table 3-1. These represent the projects in the November 2009 version of the Integrated Delivery Schedule as well as the projects previously anticipated to be completed by 2010. Based on new project scheduling, some of the projects originally scheduled with early start dates are now delayed beyond the 2020 timeframe. © International Mapping Associates

congressional authorization of three projects in WRDA 2007. As noted in NRC (2008), the lengthy and arduous CERP planning and authorization process had previously caused substantial delays in CERP project implementation. Out of frustration with the pace of progress, the state of Florida expedited several projects with full state funding, bypassing the U.S. Army Corps of Engineers (USACE)

project planning and authorization process at their own risk. However, 10 years post CERP authorization, 7 PIRs out of roughly 45 total have been finalized (although 3 others have been completed in draft form). Four PIRs have been approved by the USACE chief of engineers, and three projects have received congressional authorization for construction (see Box 3-1), enabling the flow of federal funding to these three projects, if appropriated. As of June 2010, four additional CERP projects (C-43 West Basin Storage Reservoir; C-111 Spreader Canal, Western Phase; Broward County Water Preserve Areas; and the Biscayne Bay Coastal Wetlands, Phase 1) are being considered for inclusion in the next WRDA bill, which when passed would greatly expand the number of projects eligible for federal appropriations for construction. Meanwhile, the state of Florida is expediting construction of the C-111 Spreader Canal, Lakeside Ranch stormwater treatment area (STA), and Biscayne Bay Coastal Wetlands projects and some land clearing for the C-43 Reservoir with state funding.

Although no CERP projects are anticipated to be fully constructed by the end of 2010, a few project subcomponents that will deliver restoration benefits have been completed or are nearing completion. These early benefits are described in this section. Also, groundbreaking ceremonies were held in January 2010 for the CERP Picayune Strand and state-expedited construction starts on the C-111 Spreader Canal, Western portion and Biscayne Bay Coastal Wetlands, Phase 1. Additionally, the Acme Basin B Project, originally part of the CERP but no longer considered a CERP project, was completed by the state of Florida as of March 2010. These projects and their documented and/or anticipated benefits are discussed in this section. NRC (2008) reported on a number of CERP proj-

BOX 3-1
Summary of Congressionally Authorized
Projects with Approved PIRs

As of April 2010, three Comprehensive Everglades Restoration Plan (CERP) projects with approved program implementation reports (PIRs) have been congressionally authorized—Indian River Lagoon-South (IRL-S), Picayune Strand Restoration, and Site 1 Impoundment. Ten projects were also conditionally authorized in the Water Resources Development Act of 2000 (WRDA 2000), subject to approval of their PIRs by the authorizing committee (see Table 3-1). However, most of these conditionally authorized projects will need to go through the authorization process again because of substantial changes in project scope or budget during project refinement in the development of the PIRs (S. Appelbaum, USACE, personal communication, 2010).

continued

BOX 3-1 Continued**Indian River Lagoon-South**

The IRL-S project (Figure 3-1, No. 8), an approximately \$1.5 billion component of the CERP (in 2007 dollars), is located northeast of Lake Okeechobee. The C-44 Basin Storage Reservoir is subsumed within the overall IRL-S project, to which are added the C-25 and C-23/C-24 North and South Storage Reservoirs. The original Yellow Book plan (USACE and SFWMD, 1999) was limited to these four storage reservoirs, but the project plans have since been significantly altered. The four storage basins are now proposed to provide 130,000 acre-feet of water storage, a substantial decrease in storage from the 389,000 acre-feet of storage proposed in the Yellow Book. An additional 65,000 acre-feet of storage are proposed through wetland restoration and utilization of three natural storage areas on 92,000 acres of land and in four new STAs. Finally, 7.9 million cubic yards of muck will be dredged from the St. Lucie River and Estuary to provide 2,650 acres of clean substrate within the estuary for recolonization of marine organisms. The original Yellow Book plan aimed to reduce damaging flows to the St. Lucie Estuary and the IRL-S while also providing water supply for agriculture, thereby reducing demands on the Floridan aquifer. However, the PIR included added benefits for enhanced phosphorus and nitrogen reduction, improved estuarine water quality, restored upland habitats, increased spatial extent of wetlands and natural areas, and more natural flow patterns (USACE and SFWMD, 2004a; SFERTF, 2007). In fiscal year (FY) 2010, \$26 million in federal funding was appropriated for the IRL-S project.

Picayune Strand Restoration

Located in western Collier County, the Picayune Strand Restoration project (Figure 3-1, No. 7) will restore and enhance more than 55,000 acres of wetlands in Southern Golden Gate Estates, an area once drained for development. The project will also improve the quality and timing of freshwater flows entering the Ten Thousand Islands National Wildlife Refuge, while maintaining flood protection for neighboring communities. This \$393 million project (in 2007 dollars) includes a combination of spreader channels, canal plugs, road removal, pump stations, and flood protection levees. This project is one of the most significant for increasing the spatial extent of natural wetlands (USACE and SFWMD, 2005b; SFERTF, 2007).

Site 1 Impoundment (Fran Reich Preserve)

Located in Palm Beach County south of the Arthur R. Marshall Loxahatchee National Wildlife Refuge (LNWR), the Site 1 Impoundment (also called the Fran Reich Preserve) Project (Figure 3-1, No. 2) includes an aboveground reservoir adjacent to the Hillsboro Canal with a storage capacity of 6,400 acre-feet, an inflow pump station, spillways, and seepage management structures. Once completed, supplemental deliveries from the impoundment will reduce demands on Lake Okeechobee and LNWR, and the impoundment pool will also provide groundwater recharge and reduce seepage from adjacent natural areas. The impoundment will also serve to reduce freshwater flows and pulsed releases to downstream estuaries. The cost of the project has been estimated at \$84 million (in 2007 dollars) (USACE and SFWMD, 2006; Williams et al., 2010). With \$41 million in funding from the American Recovery and Reinvestment Act stimulus, construction is anticipated to begin in late 2010 (M. Magley, USACE, personal communication, 2010).

ects with incremental benefits (e.g., Loxahatchee [L-8 Basin] Reservoir), and that information will not be repeated here unless new information on benefits is available or new progress has occurred in the past two years.

Picayune Strand

The Picayune Strand project (Figure 3-1, No. 7, and Figure 3-2), currently under way, aims to restore and enhance more than 55,000 acres of public lands by plugging and filling canals and returning sheet flow to the project site and adjacent natural areas, including the Fakahatchee Strand State Preserve, Florida

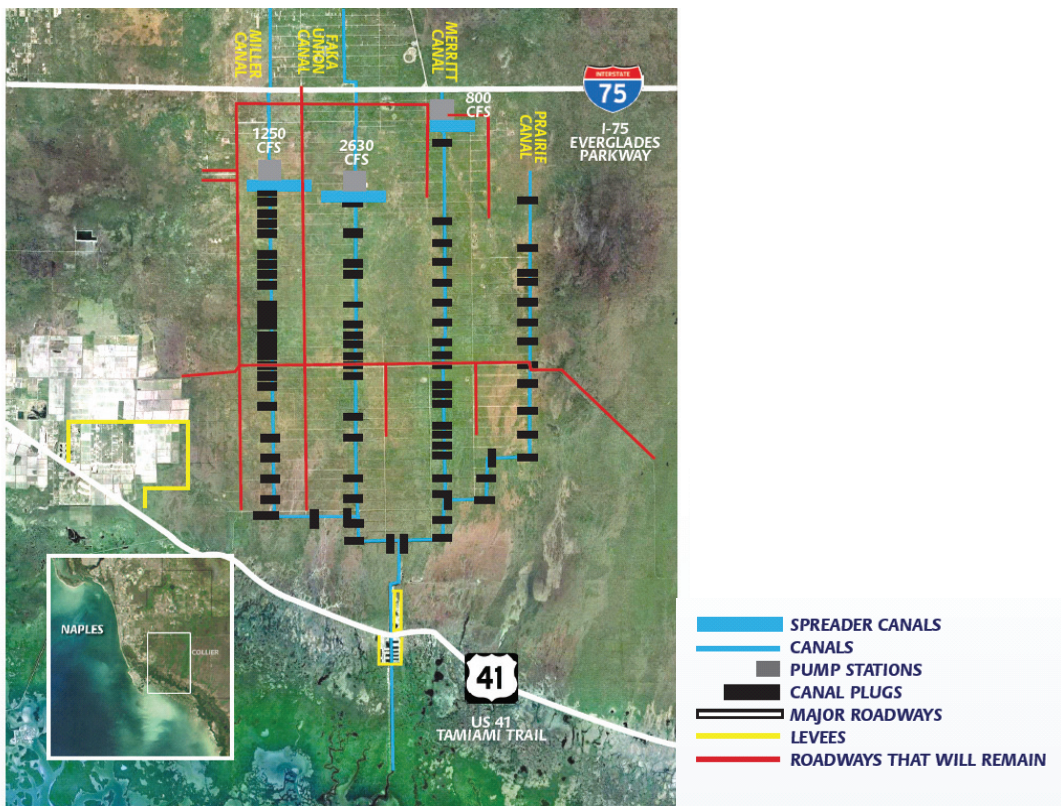

FIGURE 3-2 Components of the Picayune Strand project include road removal, canal plugs, pump stations, spreader canals, and levees.

SOURCE: USACE and SFWMD (2010b).

Panther National Wildlife Refuge, Ten Thousand Islands National Wildlife Refuge, and Collier Seminole State Park. This project was previously expedited by the state of Florida, but the remainder of the project will be funded by the federal government. With expedited state funding, 65 miles of roads were removed, and 7 miles of Prairie Canal adjacent to the road removal area were plugged and filled in 2007. Two pump stations were also designed and permitted. The federal government will complete the project in three additional phases focused on the three remaining canals—Merritt, Faka Union, and Miller. In 2009, the USACE received \$65 million in appropriations for this project (including nearly \$41 million in stimulus funding) and awarded the contract for the Merritt portion of the project. In the Merritt portion, expected to be completed by 2012, the USACE will plug 13.5 miles of canal and remove non-native vegetation and 95 miles of road. A monitoring program is in place to document hydrologic and vegetation responses to the restoration efforts. Williams et al. (2010) state that water levels have been raised in 13,000 acres of habitat by the work to date by reducing canal-related drawdowns in nearby wetlands, although significant vegetation responses to the hydrologic changes have not yet been documented (Chuirazzi and Duever, 2010). Anticipated hydrologic improvements upon full project construction are shown in Figure 3-3.

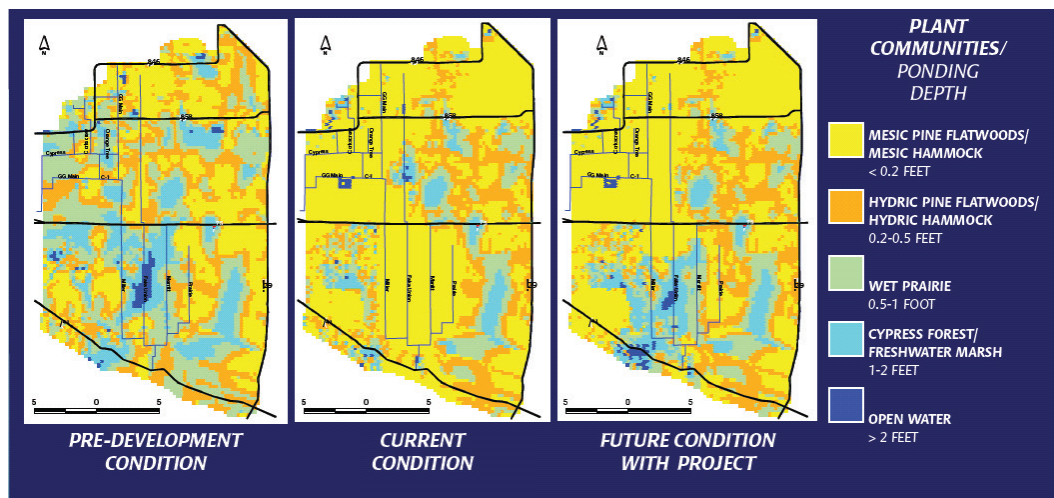

FIGURE 3-3 Average wet season water depths at Picayune Strand under pre-drainage, current, and projected future (with project) conditions.

SOURCE: USACE and SFWMD (2010b).

C-111 Spreader Canal

The C-111 Canal was built in 1966 for flood control in southern Miami-Dade County, to drain agricultural lands south and west of Homestead. The project ultimately redirected water flow to the east, thereby reducing flow through Taylor Slough and into the northeastern portions of Florida Bay, altering the salinity of the bay and the ecology of both regions. The C-111 Spreader Canal project (Figure 3-1, No. 12) is designed to improve the amount and timing of discharges in Taylor Slough, salinity levels in western Florida Bay, and water distribution and timing in the Southern Glades and Model Lands (Figure 3-4; USACE and SFWMD, 1999).

Based on the concept of incremental adaptive restoration (IAR; NRC, 2007), the project has been divided into two phases accompanied by separate PIRs (USACE and SFWMD, 2009b) and includes a pilot-scale test project (described

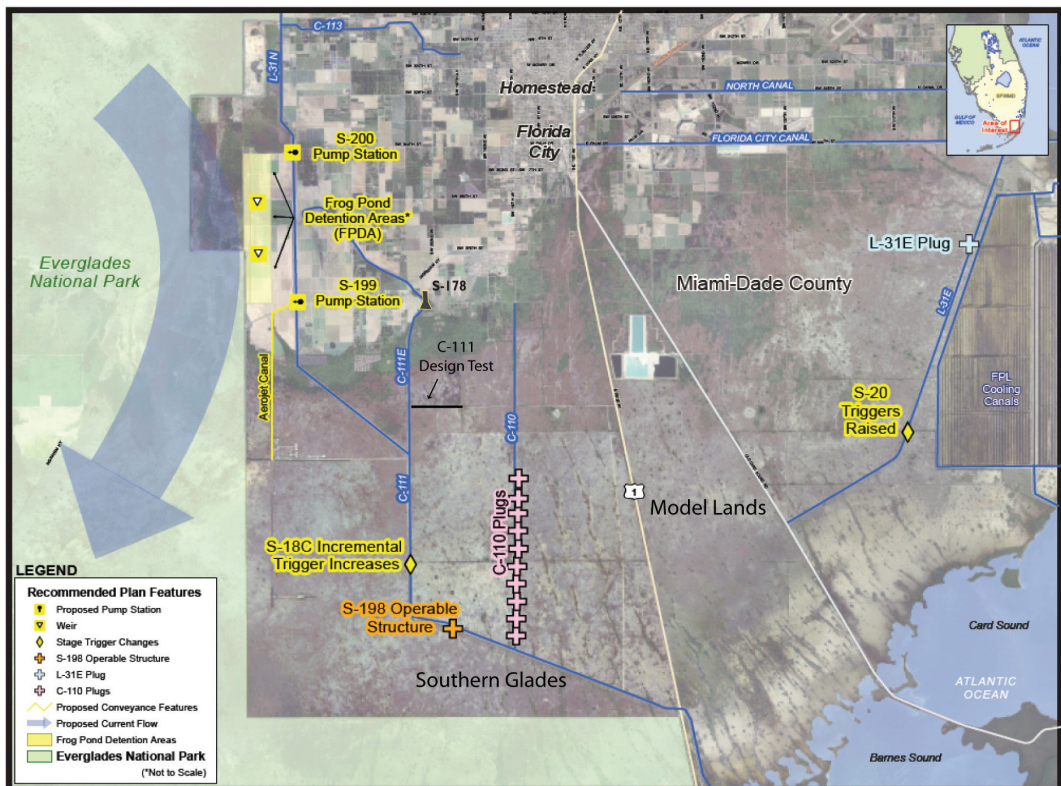

FIGURE 3-4 Features of the western phase of the C-111 Spreader Canal Project.

SOURCE: Modified from USACE (2009b).

later in this chapter). This approach allows for progress on the western features of the project (PIR 1), while uncertainties about certain design features in the spreader canal features (PIR 2) are being resolved. In January 2010, the SFWMD expedited construction on the western phase, which includes a 590-acre Frog Pond detention area, modifications to increase the water level in the Aerojet Canal, and two pump stations (Figure 3-4). These features will create a mound of groundwater (a hydraulic ridge), thereby preventing groundwater seepage out of Everglades National Park and improving water levels and flows in Taylor Slough and increasing water deliveries to northeastern Florida Bay. The project also includes a new structure (S-118) in the C-111 Canal, plugs in the C-110 Canal to reduce drainage of sensitive wetlands, and changes in the open and close trigger stages at two structures (Figure 3-4) to lengthen hydroperiods and increase sheet flow within the Southern Glades and Model Lands while maintaining flood protection. The western project only redistributes existing water and does not provide any new water to the natural system (USACE and SFWMD, 2009a). Given the potential for water quality impacts in Taylor Slough and the Everglades Model Lands such as those noted in Surratt et al. (2010), monitoring in receiving wetlands and adaptive management will need to be important components of the project. The western project is estimated to be completed by 2011; therefore, it is too soon to report upon any observed natural system restoration benefits from this project.

The 2009 biological opinion for the C-111 Spreader Canal Western Phase 1 demonstrates the ability of CERP project delivery teams to work cooperatively with the U.S. Fish and Wildlife Service to adjust initial project designs to allow for incremental implementation of operation, monitoring, and adaptive management for species and habitat restoration (USFWS, 2009a). Like most CERP projects, the C-111 Spreader Canal project has the potential to benefit multiple listed species, but the degree of benefit varies by species and the scale of analysis (e.g., unavoidable local negative impacts vs. landscape-level benefits) and assumes completion of subsequent CERP projects that would actually provide additional water to the system.

After significant delays the project appears to now be progressing. The C-111 Spreader Canal project was conditionally authorized in WRDA 2000 and originally scheduled for completion in 2008. Its estimated cost has risen from \$94 million in 1999 to \$131 million in 2008 dollars (SFERTF, 2009). In 2004 the state of Florida identified the C-111 Spreader Canal project as an Acceler8 project (see Chapter 2; now called “expedited projects”), and since that time has committed more than \$40 million to construction and land acquisition (SFWMD, 2010d). The project is being considered for inclusion in the next WRDA bill, which when passed would allow for appropriations of federal funds to increase the pace of project completion.

Biscayne Bay Coastal Wetlands—Phase 1

The Biscayne Bay Coastal Wetland—Phase 1 project will construct a system of pumps, spreader canals, and culverts to adjust the quantity, quality, timing, and distribution of freshwater to Biscayne Bay. The project aims to significantly reduce the damaging effects of existing point-source discharges to the bay and restore a more natural salinity regime in the coastal tidal wetlands. The project will be implemented in two phases, necessitating two PIRs. A draft of the Phase 1 PIR was released in March 2010 (USACE and SFWMD, 2010d).

The state of Florida has expedited portions of this project, with construction starts on the L-31E and the Deering Estate components in January and May 2010, respectively. The Deering Estate component involves a 500-foot canal extension, pump station, and spreader structure to improve water delivery. The L-31E Canal component will isolate the L-31E Canal using gated culverts and will move more water into Biscayne Bay wetlands using five new pump stations and several spreader structures (Figure 3-5). A third project component that is not yet under construction, Cutler Flow-way, consists of a pump station, conveyance canal, box culverts, spreader canals, and ditch plugging to increase water flows to saltwater wetlands.

The state of Florida had originally planned to expedite the entire Biscayne Bay Coastal Wetlands—Phase 1 project, but the South Florida Water Management District (SFWMD) is now relying on federal funding for portions of the project due to fiscal constraints. The state is planning to expedite the construction of the entire Deering Estate component, much of the Cutler Flow-way, and 4 (out of 10) culverts in the L-31E Flow-way. As of April 2010, the SFWMD had completed installation of the four culverts in the L-31E component, and the state's portion of the Deering Estate component was anticipated to be completed by August 2011 (T. Teets, SFWMD, personal communication, 2010). According to the Integrated Delivery Schedule (USACE, 2009a), Phase 1 of the Biscayne Bay Coastal Wetlands project is anticipated to be completed by 2012, but this schedule is dependent upon timely completion of the PIR, congressional project authorization, and subsequent federal appropriations. Given the recent construction starts, it is too early to report any natural system restoration resulting from this project.

Acme Basin B

Phase 2 of the Acme Basin B project (Figure 3-1, No. 11), a 300-acre stormwater impoundment that will divert urban runoff from the A.R.M. Loxahatchee National Wildlife Refuge (LNWR), was anticipated to be completed in June 2010. Phase 1 of this project included canal conveyance improvements and a new pump station to pump the diverted stormwater toward STA-1E for

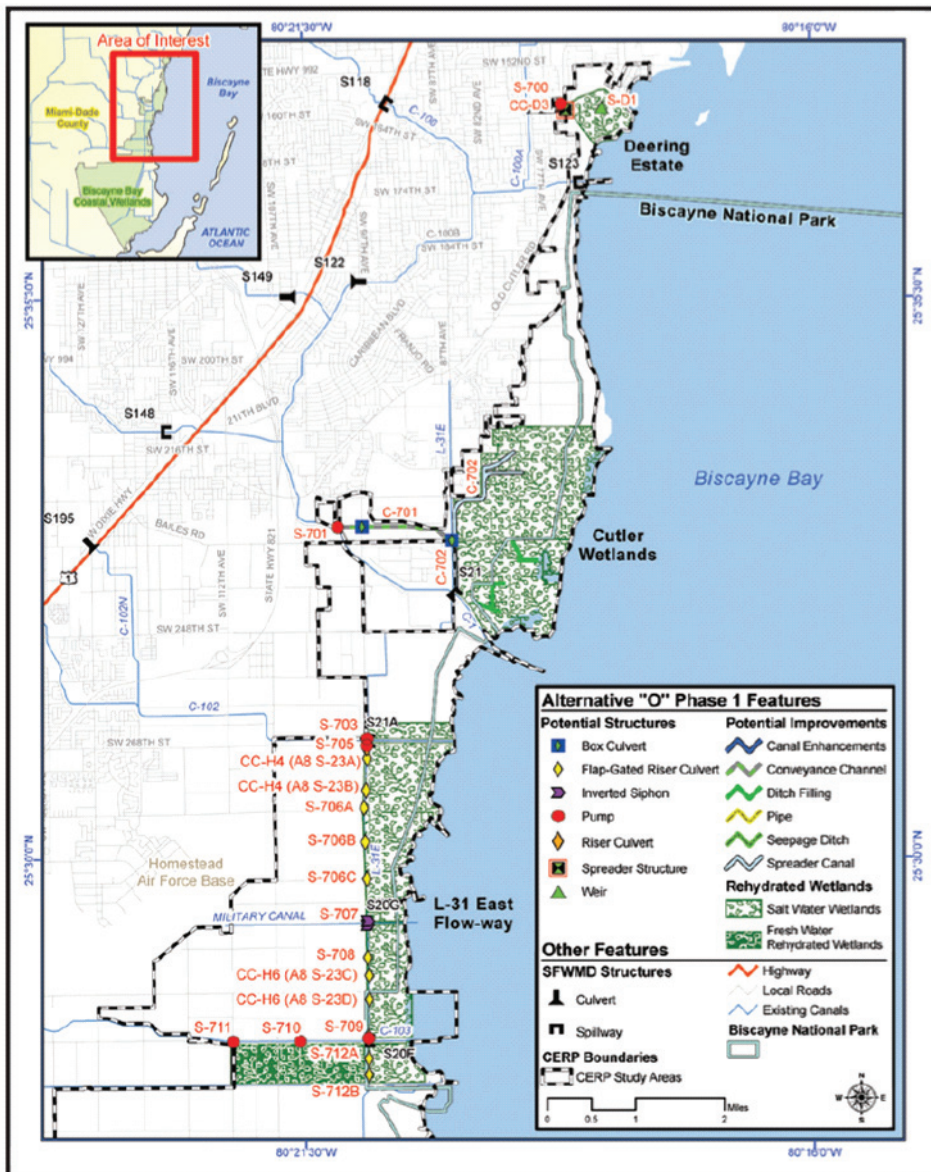

FIGURE 3-5 Locations of the three project areas within Biscayne Bay Coastal Wetlands—Phase 1: Deering Estate, Cutler Wetlands, and L-31 East Flow-way.

SOURCE: USACE and SFWMD (2010d).

treatment before it enters LNWR. The state has expedited this project with state and local funds, and although it was originally a CERP project, the CERP planning process has been discontinued, meaning that federal cost sharing of this project is unlikely. However, the Acme Basin B project is the first of the originally proposed CERP projects to be completed, even though it is no longer considered a CERP project (L. Gerry, SFWMD, personal communication, 2010).

Pilot Projects

Pilot projects are important components of the CERP, enabling scientists and engineers to test the capacity of new technologies or approaches and to refine future project design. Although the CERP pilots themselves are not expected to lead directly to natural system restoration progress, the learning that they generate has great value and can be used to improve the extent of natural system restoration and the efficient use of resources. In this light, in the next section the committee discusses what has been learned from the CERP pilot studies to date.

Aquifer Storage and Recovery Pilot Studies and Regional Study

Aquifer storage and recovery (ASR) is a major water storage component of the CERP intended to store as much as 1.7 billion gallons per day (or 6.3 million m³/day) for recovery during wet periods and for use during dry periods. The Yellow Book plan (USACE and SFWMD, 1999) called for about 333 wells, each with a capacity of 5 million gallons per day (MGD). The unprecedented scale of the proposed ASR network raised a number of technical and scientific concerns that were addressed in previous NRC reports (NRC, 2001, 2002a). These concerns included possible regional hydrogeologic impacts of concentrating so many wells in the Upper Floridan aquifer, limited subsurface information for planned well sites, quality of both source water and recovered water, local performance of wells over time, and ecological effects of introducing large volumes of recovered water with altered chemistry into the ecosystem.

Local pilot ASR wells and regional scientific and engineering studies have been under development since 2003 to address these uncertainties and concerns (see Figure 3-6). Exploratory wells have been drilled at five pilot locations around Lake Okeechobee and along the Hillsboro Canal and the Caloosahatchee River, and 5 MGD ASR systems have been constructed at two sites (Hillsboro Canal, Kissimmee River). Funding limitations prevented construction at two sites (Port Mayaca and Moore Haven) and the Floridan Aquifer proved too sandy for ASR at the Caloosahatchee site. The Port Mayaca pilot was to be a multi-well facility that would test well interactions, an important concern for full ASR implementation.

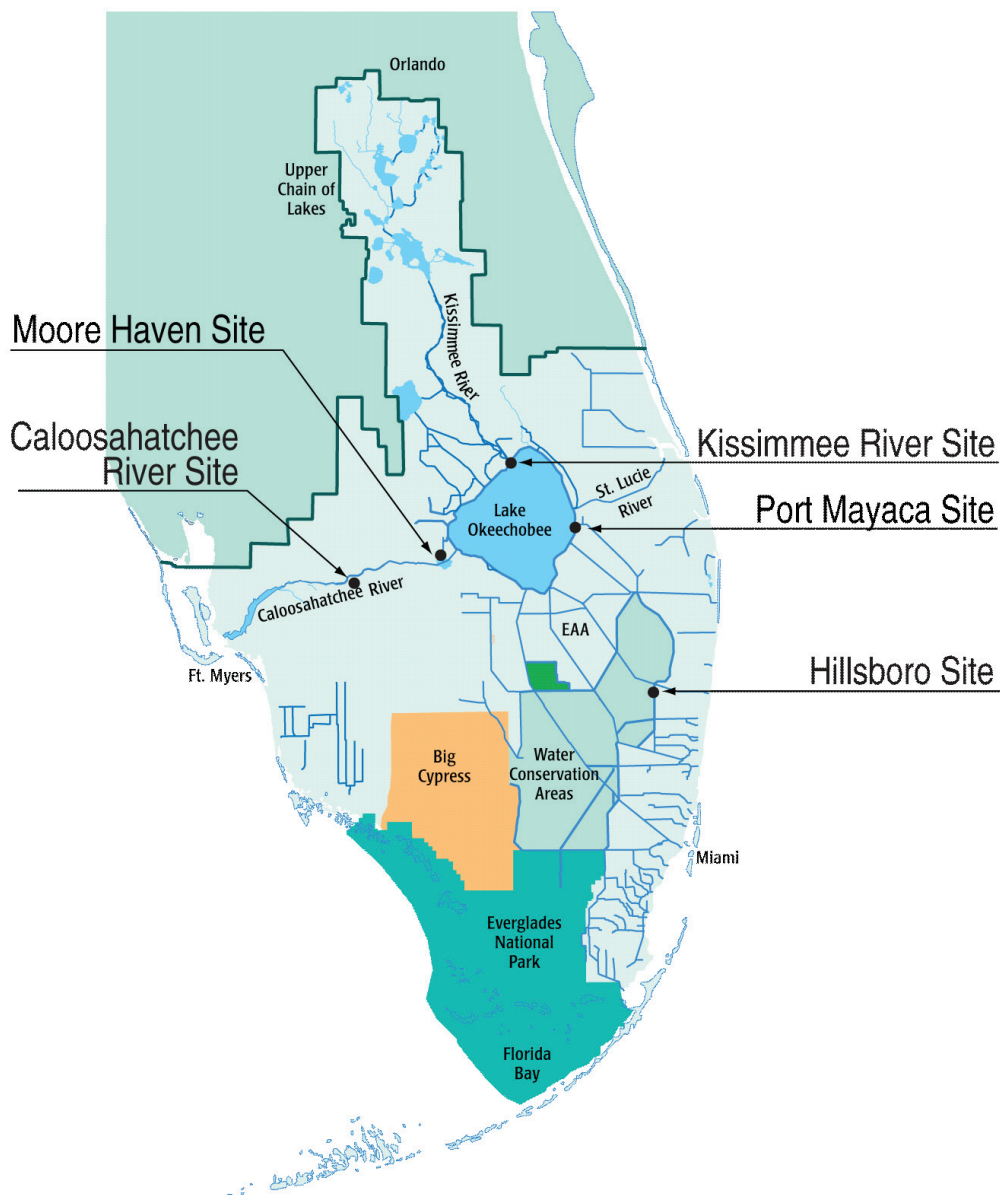

FIGURE 3-6 Locations of the five originally planned CERP ASR pilot projects. Ultimately, pilots were constructed only on the Kissimmee River and the Hillsboro sites because of funding limitations or poor site conditions.

SOURCE: USACE and SFWMD (2008).

Geochemical studies of interactions between source water and the water quality and lithology of the Floridan aquifer system have been conducted using data from several operational ASR facilities. Biological studies have included research on microbial communities of the Upper Floridan aquifer and ecological monitoring at the pilot well locations. To address regional issues, extensive hydrogeologic, water quality, and ecological monitoring networks have been installed throughout the CERP area, geophysical studies of the Upper Floridan aquifer have been completed, and large-scale groundwater modeling is under development.

ASR pilot studies have been hindered by funding delays, lengthy contractor negotiations, and slower-than-anticipated permitting processes. Cycle tests to better understand the relationship between storage zone properties, water quality, recovery rates, and recharge are now under way at the Hillsboro Canal and Kissimmee River sites, although these tests will be of shorter duration and with fewer monitoring wells than recommended in the 2002 NRC report. The regional study has made good progress on hydrogeologic and geophysical studies of the Upper Floridan aquifer. Groundwater modeling and studies of biogeochemical processes, water quality, aquifer mixing processes, ecotoxicology, and ecological impacts are roughly 20-50 percent completed in addressing questions raised by the ASR issue team and the NRC. Current plans call for initial groundwater model results by 2010, cycle testing at pilot sites through 2011, completion of the regional study by 2012, and publication of the CERP ASR Project Implementation Report by 2015.

Arsenic leaching could pose a serious challenge to ASR implementation for the CERP. Injection of water with relatively high levels of dissolved oxygen can lead to oxidation of arsenopyrite and release of arsenic into well water during storage. Several operational ASR facilities in Florida have exceeded the new federal arsenic standard of 10 parts per billion (ppb) (Mirecki, 2004), and concentrations reached 140 ppb in water recovered from the first cycle test at the Kissimmee pilot ASR. Longer storage in the second cycle test at Kissimmee decreased concentrations below the regulatory criteria of 10 ppb (Orlando Ramos-Gines, USACE, personal communication, 2010). The operating costs and energy requirements associated with ASR facilities are also of concern. Research is under way to reduce the costs and energy demand by non-pumping recovery under artesian conditions and by optimizing pumping rates for maximum recharge and recovery flow (Mirecki, 2010).

With a planned capacity of 462,000 acre-feet, ASR is the largest planned storage component in the CERP (NRC, 2005). In the 2008 ASR Interim Pilot Report (USACE and SFWMD, 2008), the project team concluded that “no ‘fatal flaws’ have been uncovered that might hinder the implementation of CERP ASR.” Whether fatal or not, the delays, site limitations, and funding constraints

that have compromised the ASR pilots, as well as unanticipated water quality issues, are indicative of the challenges facing large-scale use of ASR. NRC (2005) cautioned against excessive reliance on storage solutions like ASR that would involve complex design and construction measures, require frequent equipment maintenance, and have substantial energy costs for operation. The final ASR pilot report should analyze a reasonable storage capacity for ASR in the CERP, given new information on aquifer conditions and water quality constraints, and should address the benefits and limitations of ASR to meet the storage and water delivery needs of the CERP over both short and long timescales. The final ASR pilot report should also address the capital and operational costs of ASR and objectively compare ASR against other, less energy-intensive storage options. Only with this information can decisions be made about the value of ASR to the CERP and at what scale.

L-31N Seepage Management

The potential for significant eastward groundwater seepage and flooding of urban and agricultural lands in Miami-Dade County is one of the most significant challenges to CERP plans to decompartmentalize the water conservation areas and to increase flows via water conservation area (WCA) 3B into northeast Shark River Slough in Everglades National Park. The L-31N Seepage Management Pilot Project is intended to inform the design of large-scale seepage management solutions for the L-31N levee. To reduce flooding risks the project has been re-located from L-31N to the southeastern corner of WCA-3B along the L-30 levee and canal.

In the pilot project, two seepage management approaches—a slurry cutoff wall and a steel sheet pile wall—are compared using injection and extraction wells to manipulate groundwater levels and flows (Figure 3-7). Two segments of slurry wall, each 450 feet in length, will be placed at an elevation varying between –63 and –68 feet (77 to 82 feet below ground surface). A 100-foot steel sheet pile wall will be placed between the two slurry wall segments and extended to an elevation of –22 feet. This will leave a 41-foot vertical gap (“window”) underneath the sheet pile wall, allowing seepage flow at depth. Injection wells adjacent to the window (east of the existing L-30 levee) will be installed to create a hydraulic barrier that can be manipulated to vary seepage volumes through the window. Six monitoring wells will be placed on the west side of the window to monitor velocity, temperature, and pH of seepage flowing through the window, and an array of wells will monitor surface and groundwater hydrology and water quality for two years. Seepage management technologies will be evaluated in terms of ease of installation, effectiveness, and cost.

The L-31 pilot project design was approved by the assistant secretary of

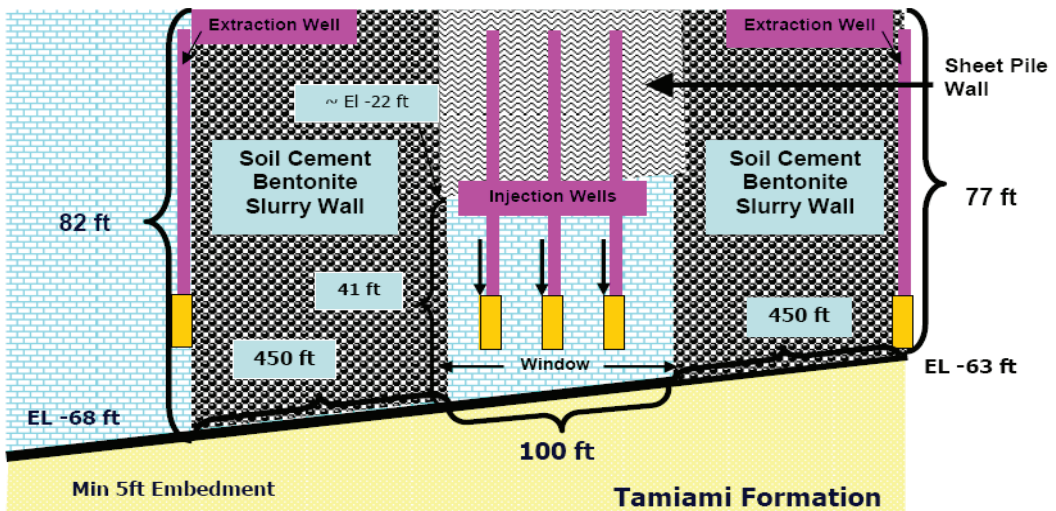

FIGURE 3-7 Schematic diagram of the slurry and sheet pile wall design that will be tested in the L-31N Seepage Management Pilot Project. Placement of injection and extraction wells is also shown.

NOTE: The depths include the wall height 14 feet into the L-31N levee. Extraction wells are located approximately 100 feet from the ends of the barrier wall.

SOURCE: USACE and SFWMD (2009b).

the Army in November 2009. The project is expected to cost \$15-16 million. Construction of the seepage management pilot was to begin in September 2009, but the pilot has recently been delayed (USACE and SFWMD, 2009b; K. Tippett, USACE, personal communication, 2010).

An additional small-scale seepage study is under way, funded by the Miami-Dade Limestone Products Association (LPA), along the L-31N levee, approximately 1 mile south of the CERP seepage pilot project. The LPA seepage control pilot is part of a larger proposal to privately fund groundwater seepage control adjacent to Everglades National Park to mitigate the effects of expanded limestone mining in the Lake Belt region. In 2009, the LPA constructed a 1,000-foot slurry wall, approximately 18 feet deep. National Park Service scientists evaluated the results and found the effects of the seepage barrier to be inconclusive. The LPA has a groundwater tracer test planned for summer 2010 to better evaluate the changes in flow direction and velocity at the location of the slurry wall and the need for any design changes. The LPA efforts offer the potential

for substantial remediation at little to no public cost (R. Johnson, NPS, personal communication, 2010).

Decomp Physical Model (DPM)

As explained in Chapter 2, canals and levees within the WCAs have disrupted the sheet flow that created and maintained the characteristic Everglades landscape features, such as the ridge and slough. The objective of the WCA-3 Decpartmentalization and Sheet Flow Enhancement (Decomp) project is to restore sheet flow by backfilling selected canals and removing levees. The scheduled completion date is 2020 at a cost of \$315 million (SFERTE, 2009), although these numbers depend on timely completion of Mod Waters and resolution of political challenges and scientific uncertainties. Recreational hunting and fishing groups prefer to keep the canals open, but scientists hypothesize that complete backfilling may be required to restore flow patterns and sediment transport processes that maintain the ridge and slough landscape. There is also uncertainty about the need for partial versus complete removal of levees and about the impact of higher water levels in WCA-3B and northeast Shark River Slough on seepage to the Lower East Coast.

The Decomp Physical Model (DPM) is a large-scale field experiment to inform project planning decisions by reducing uncertainty associated with (1) the hydrologic and ecological necessity to backfill canals and (2) the relationship between flow and ecological processes in the ridge and slough landscape (Figure 3-8). The study will install 10 gated 60-inch pipe culverts on the L-67A levee to provide a maximum discharge capacity of 750 cubic feet per second (cfs) and open a 3,000-foot gap in the L-67C levee (Figure 3-9). A 3,000-foot section of the adjacent L-67C canal will be divided into three 1,000-foot sections for complete, partial, or no backfilling. The culverts will be managed to create two annual pulsed flow events between October and January that should generate downstream flow velocities sufficient to entrain and redistribute sediments. A before-after-control-impact (BACI) design will be used to compare hydrology, sediment transport, water quality, and biotic variables in the flow-way below the three canal treatments and in a control region outside of the flow-way. According to the current schedule, the DPM will be installed and tested between July 2011 and July 2014. The *before* and *after* monitoring periods will consist of 24 months each, beginning October 2010. Two pulsed-flow events are scheduled for 2012 and 2013 (Sklar et al., 2009a; USACE and SFWMD, 2010c).

In reviewing Decomp progress and the DPM in particular, the committee considered three basic questions: (1) Is there sufficient scientific uncertainty to warrant a relatively costly (>\$10 million) and time-consuming study to compare alternatives for restoring sheet flow to the ridge and slough landscape? (2) Can a

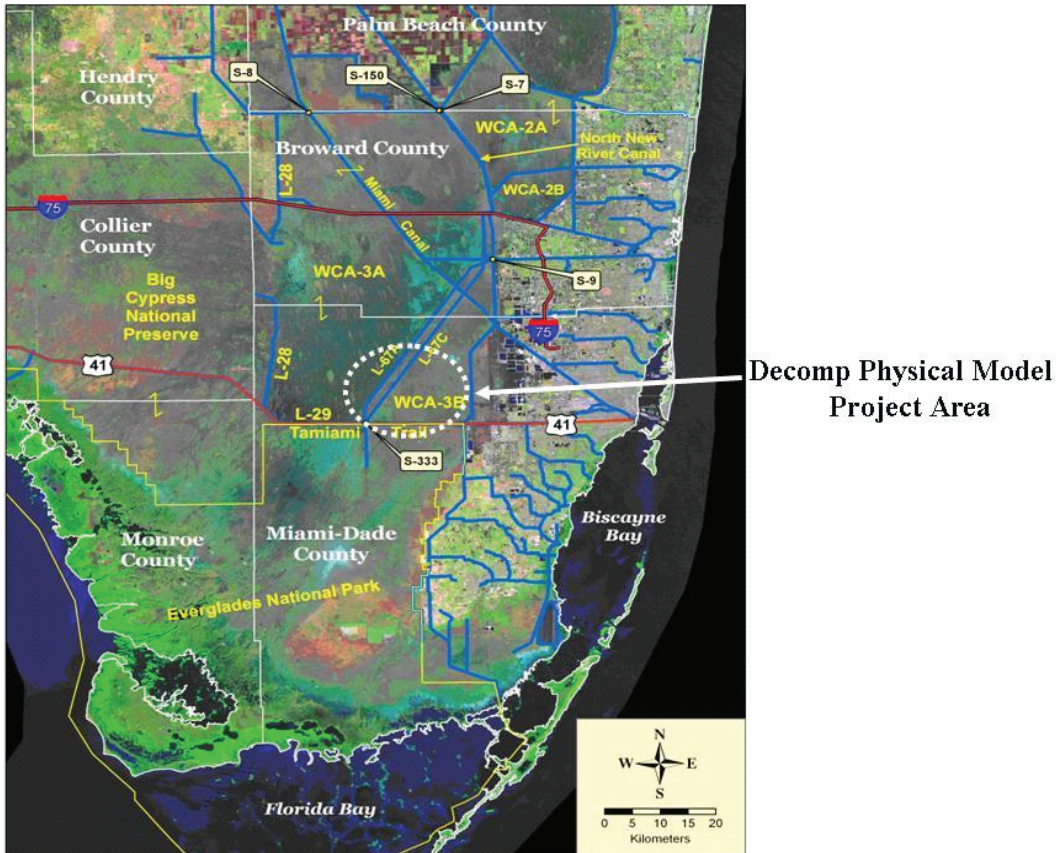

FIGURE 3-8 Location of the Decomp Physical Model.

SOURCE: http://www.evergladesplan.org/pm/projects/docs_12_wca3_model.aspx.

short-term manipulation at the scale and duration of the DPM reduce uncertainties enough to warrant the investment? (3) Is the DPM as designed capable of resolving the debate regarding levee removal and canal backfilling?

Scientific uncertainty. CERP scientists have highlighted six uncertainties associated with Decomp (Sklar et al., 2009a), including (1) the need for complete canal backfilling; (2) ecological benefits from restoring sheet flow and connectivity; (3) effects of levee removal and the need for complete levee removal; (4) depth and hydroperiod tolerance of tree islands and other ridge and slough communities; (5) effects of water levels in WCA-3B and northeast Shark River Slough

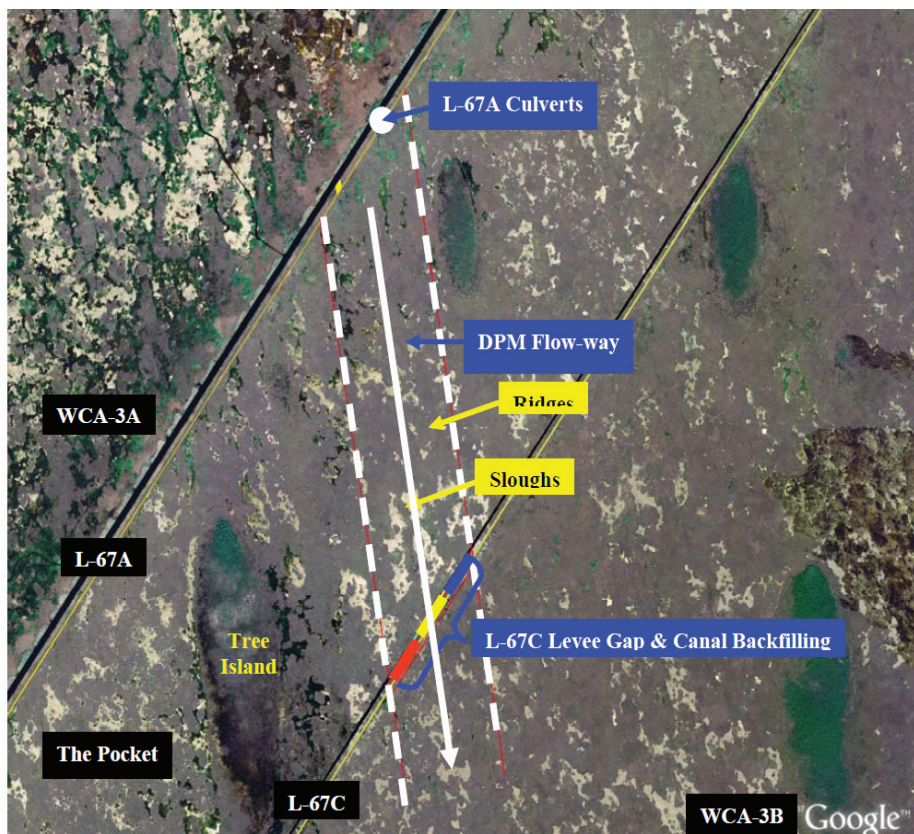

FIGURE 3-9 Schematic illustrating the features of the Decomposition Physical Model. The major hydrologic elements (L-67A culvert, flow-way, L-67C canal backfilling, and L-67C gap) are highlighted in blue, the ecological elements (ridges, sloughs, and tree islands) in yellow, and location identifiers in black. The gap in the L-67C is 3,000 feet.

SOURCE: Sklar et al. (2009a).

on seepage to the Lower East Coast; and (6) better parameterization of hydrologic models used to evaluate design alternatives. The DPM mainly addresses questions 1 and 2. A 2003 NRC report recognized the ecological role of sheet flow as a critical uncertainty in CERP implementation (NRC, 2003a). Field and laboratory research since that time, which is summarized in Chapter 6, has elucidated present flow regimes and their relationship to sediment transport in well-preserved and degraded ridge and slough landscapes (Harvey et al., 2005, 2009; Larsen et al., 2007, 2009a; Ho et al., 2009; Variano et al., 2009). Although

much scientific uncertainty remains about the flow regimes that established the ridge and slough system (Noe et al., 2010), and although the DPM will certainly contribute to understanding the hydroecological implications of restoring sheet flow, this committee concludes that the DPM's cost would probably not be justified if based mainly on uncertainty about the ecological benefits of restoring sheet flow and connectivity to WCA-3.

Instead, the main justification for the DPM is to help resolve the debate over the need for complete versus partial or no canal backfilling. This debate is as much political and economic as it is scientific; complete levee removal and backfilling of canals would seem an obvious choice if restoration of pre-drainage flows were the only consideration. The two main arguments against complete backfilling are (1) the highly valued sports fishery supported by the existing canal network and (2) the high cost of completely backfilling 84 miles of existing canals (USACE and SFWMD, 2010c).

From a scientific perspective, it is well known that features such as channels, levees, and topographic depressions that alter wetland hydraulic conditions can strongly affect the storage and flows of nutrients and materials by trapping sediment and by creating preferential flow paths or "short circuits" (e.g., Kadlec, 1994; Lightbody et al., 2008; Noe et al., 2010). However, the magnitude of differences in wetland hydraulics associated with different backfilling strategies, and the ecological implications of those differences, cannot be predicted with much certainty. If the DPM can in fact improve the scientific credibility, reliability, and cost-effectiveness of the Decomp design then it could be worth the associated delays and expenses.

Ability of the DPM to reduce uncertainty. The DPM study is limited by an overall cost cap of \$10.3 million, access and environmental considerations, and operational constraints such as L-29 Canal stages and flood control concerns (Sklar et al., 2009a; USACE and SFWMD, 2010c). The L-67A culvert design and the proposed 3,000-foot gap in L-67C should suffice to generate localized flow-way velocities in excess of 3 cm/sec assuming that sufficient water is made available. The experiment will help quantify the stage response, infiltration, and seepage during re-watering of WCA-3B under Decomp. It can also refine and test hypothesized relationships between flow dynamics, sediment re-distribution, and biogeochemical processes with fast response times such as plant nutrient uptake, plant production, and decomposition. The short duration of the DPM severely limits study of the relationship between flow regime and community composition or landscape structure, which would be expected to change much more gradually to restoration of sheet flow (Larsen and Harvey, 2010).

The DPM will produce the most detailed observation data to date on the hydrology and ecology of sheet flow in the ridge and slough system. Neverthe-

less, two years may not be enough to generate a sufficient range of conditions to distinguish hydrodynamics and geomorphic processes in the different canal treatments (Noe et al., 2010). The short duration will especially limit the ability to sort out the implications of altered nutrient levels and distribution or responses of plants and animals to different treatments given year-to-year vagaries of climate and weather (e.g., precipitation and temperature extremes) and the complex effects of canals on population processes (Rehage and Trexler, 2006). The cost cap could also prove problematic if the project hits unforeseen delays or higher than expected construction costs.

Ability to detect significantly different responses among alternatives. The BACI design is a well-established approach to environmental impact assessments but is not without its limitations (Stewart-Oaten and Bence, 2001). BACI control sites are not strictly experimental controls but rather “covariate” sites whose value improves with replication. BACI designs are based on variations in time and thus are sensitive to inertia, lags, and serial autocorrelation in observed variables. These are issues that can be addressed using appropriate statistical models, longer time series, and greater replication (Stewart-Oaten and Bence, 2001), but the DPM design is short and provides only two “control sites” and three replicates at each time-space sampling point.

The power analysis provided in the Science Plan (Sklar et al., 2009a), which is based on the simplest form of BACI model, provides some indication of the relatively low power of the DPM design for strict hypothesis testing. For example, grand means of variables before and after treatments must differ by more than four times the within-period variability to detect an effect at a significance level (p -value) less than 0.05. It would not be surprising if canal backfilling options did not differ at this significance level given the limited time and DPM design.

The committee raises the issue of replication to highlight a question that seems inadequately treated in current planning documents: How will DPM results be used in resolving the current debate and stakeholder conflicts over levee and canal modifications? The DPM Science Plan describes hypothesis testing and model refinement as the main outcomes. But as discussed by Stewart-Oaten (1996), passing or failing a 0.05 significance test is a poor basis for environmental decision making. Refinements to models such as the South Florida Water Management Model (SFWMM) and the Everglades Landscape Model (ELM) and validation of the RASCAL (Ridge and Slough Cellular Automata Landscape) are important benefits of the DPM (USACE and SFWMD, 2010c) but are unlikely to help to resolve conflict over canal backfilling. The DPM study is the first major application of active adaptive management to CERP implementation, so it is especially important that the process for applying DPM findings to Decomp design be included in DPM project planning. Given the limitations of

DPM in terms of duration and replication, CERP scientists and planners should consider other means of synthesizing and communicating results to facilitate decision making under uncertainty (Raiffa, 1968; Morgan and Henrion, 1990). For example, a Bayesian hierarchical modeling approach (Qian and Shen, 2007; Biggs et al., 2009; Cressie et al., 2009) could be used to evaluate results, which would give a more flexible (and many would argue, realistic) basis for evaluating the likelihood that canal treatments differ without reliance on an arbitrary significance value. Such an approach allows the posterior (post-analysis) probability distributions of differences among treatments to be analyzed, and the likelihood of particular outcomes to be assessed without reliance on a pre-determined and arbitrary “yes/no” criteria.

As another alternative, information gap analysis has proven useful in supporting decision making under uncertainty when probabilistic models are unreliable (Ben-Haim, 2001). This non-probabilistic, set-based approach requires a process model, a performance requirement, and a model of uncertainty, and allows decision makers to weigh expected benefits against risks as a function of uncertainty. Applications to water resources management and conservation management are described by Hipel and Ben-Haim (1999), Hine and Hall (2010), and Regan et al. (2005).

To summarize, the Decomposition Physical Model will improve understanding of the effects of different degrees of canal backfilling on wetland hydraulics and sheet flow, provide useful information on surface and subsurface hydrology in WCA-3B as it is re-watered, and result in exceedingly detailed hydrogeomorphic and ecological data during pulsed-flow events. For these reasons the committee supports the project as a way of advancing and improving the design of Decomposition. However, it is unlikely that the experiment can definitively resolve the debate over the need for canal backfilling. That decision will need to be made in the face of political disagreement and scientific uncertainty.

C-111 Spreader Canal Pilot

As described previously in this chapter, the C-111 Spreader Canal project has been divided into two separate phases, with a pilot project to support the planning of PIR 2, or the “eastern” project. The eastern project will replace existing portions of the lower C-111 Canal with a spreader canal to enhance sheet flow to Florida Bay and restoration efforts within the Southern Glades and Model Lands. During plan formulation, two major decision-critical uncertainties were identified that were preventing consensus on the appropriate design for the eastern phase (USACE, 2009b):

1. Based on the amount of water available for the spreader canal, what is the most appropriate alignment and design for the spreader canal that will maximize ecological restoration without adversely impacting privately owned lands?

2. Can an infiltration basin and/or source controls sufficiently improve the quality of S-178 discharges to the degree necessary to ensure that water discharged from the future spreader canal is “marsh ready”?

A canal design test was developed to address the first of these decision-critical uncertainties. Specifically, the test would address the following questions:

- How would a spreader canal affect surface- and groundwater levels to the north and south of its alignment?
- How much of the source water introduced into the spreader canal will return to C-111 and C-111E via groundwater?

The features of the design test include a 0.5-mile spreader canal, a 0.5-mile pipe to convey water to the spreader canal while keeping the test area separate from groundwater drawdown influences in neighboring canals, and a 50-cfs water discharge rate into the spreader canal. The test began operation in May 2010, with increasing durations of pumping into the spreader canal (ranging from 12 hours to 5 days) and associated surface- and groundwater monitoring at more than 40 locations before, during, and after the tests. The test is anticipated to take approximately 6 months to complete once initiated, and the results will be used to determine the appropriate design of the eastern project (USACE, 2009b; L. Gerry, SFWMD, personal communication, 2010). The test may result in some incremental restoration benefits of the surrounding wetlands, albeit over a very small area, but the pilot project should result in important learning benefits to improve the remainder of the project.

The committee is not aware of any efforts under way to address the second decision-critical uncertainty regarding the water quality of S-178 discharges. Everglades National Park scientists have voiced concerns over increased cattail growth in Taylor Slough suspected to be caused by water management changes that have increased hydroperiods and thus increased phosphorus loading. Therefore, CERP planners should take steps to help resolve the decision-critical uncertainties related to water quality discharges in the C-111 so that future progress on the eastern project can proceed.

NON-CERP RESTORATION IMPLEMENTATION

Some of the largest accomplishments and some of the greatest challenges in South Florida ecosystem restoration have been associated with non-CERP proj-

ects that are directly related to the success of the CERP in achieving its restoration goals. Projects such as the Modified Water Deliveries Project to Everglades National Park (Mod Waters) and the Everglades Construction Project have been in the works for decades, even as the CERP was being developed. The progress of the CERP is dependent upon the successful implementation and effective operation of these non-CERP projects. Therefore, although the focus of this committee's charge is on natural system restoration progress related to the CERP, progress on related non-CERP foundation projects, including documented natural system restoration benefits where feasible, is summarized in Appendix C. In this section, major non-CERP accomplishments and documented benefits from the past two years are discussed. This section builds upon the committee's prior assessments of natural system restoration progress and challenges associated with STAs, the Kissimmee River restoration, and Mod Waters (NRC, 2007, 2008).

Mod Waters

A major development since NRC (2008) is the start of construction of the 1-mile bridge on the eastern end of the Tamiami Trail, which is part of the Mod Waters project. The contract for the bridge was issued in October 2009, and the groundbreaking occurred on December 4, 2009. In its prior report (NRC, 2008), the committee outlined the long and often discouraging history of the project, focusing on the most recent barriers to improvement of the Tamiami Trail. NRC (2008) stated: "If this relatively modest restoration project cannot proceed and provide some restoration benefits, the outlook for the CERP is dismal." The committee commends the restoration program on the recent progress and recognizes the congressional leadership required to move the 1-mile bridge project forward.

NRC (2008), however, recognized that the 1-mile bridge plan was "a substantially smaller step toward restoration than was originally envisioned for Mod Waters." The previous committees stated, "It should be recognized that moving forward with the 2008 recommended [1-mile bridge] plan increases the urgency to proceed more quickly to implement the additional necessary Tamiami Trail modifications through the CERP, or some other mechanism, so that the restoration benefits for Everglades National Park outlined in the WRDA 2007 conference report⁴ can be achieved as soon as possible."

The Department of the Interior released an analysis of alternatives and a proposed plan for additional bridging along Tamiami Trail in May 2010 (SFNRC,

⁴The WRDA 2007 conference report tasked the USACE "to pursue immediate steps to increase flows to the Park of at least 1,400 cubic feet per second, without significantly increasing the risk of roadbed failure." The report also stated that flows to the park should have "a minimum target of 4,000 cubic feet per second so as to address the restoration envisioned in the 1989 [Mod Waters] Act."

2010). These efforts recognize that the 1-mile bridge under construction and the raising of the road to an elevation of 8.5 feet represent a substantially smaller step toward restoration than was originally envisioned for Mod Waters. The preferred alternative (6E) identified in SFNRC (2010) consists of an additional 5.5 miles of bridging (in four separate bridges) and road raising to support a stage of 9.7 feet in the L-29 Canal along the eastern 10.7-mile portion of Tamiami Trail, at an estimated cost of \$330 million. SFNRC (2010) states that the plan would provide the capability to convey the historical volumes of water that once passed into Everglades National Park without damage to Tamiami Trail and would accommodate flows from future projects, including the CERP. The plan also offers the potential for substantial improvements in ecological connectivity between Everglades National Park and WCA-3. Although SFNRC (2010) was released too late for detailed review by the committee, the proposal appears to be responsive to the recommendations in NRC (2008).

Everglades National Park is also moving forward with the Spreader Swale Pilot Project, which will test the capacity of spreader swales downstream of Tamiami Trail to improve the conveyance capacity of existing culvert features. The construction of two 1,000-foot by 30-foot spreader swales is anticipated to begin in June 2010. A recent modeling study (Chin, 2010) reported large increases in volumetric flows, ranging from 60 percent to 830 percent at stages of 6 feet in the L-29 Canal depending on the length of the spreader swale, the culvert dimensions, the downstream stage, and the assumed roughness in the downgradient marsh. The study, however, did not consider the effects of spreader swales at canal heights greater than 8.5 feet, even though the CERP would require canal heights as high as 9.7 feet. A full understanding of the potential value of spreader swales should consider canal stages up to 9.7 feet and compare these results to that achievable through additional culverts or bridges.

In addition to the commencement of the Tamiami Trail work, the Mod Waters project involves flood mitigation for the 8.5-square-mile area adjacent to Everglades National Park, conveyance and seepage control features, and implementation plans for monitoring and operation. Previously, the 8.5-square-mile area was protected from flooding by a much larger and more powerful pump (S-331), which drew more water than required and exacerbated seepage from Everglades National Park. A newly constructed pump station (S-357; Figure 3-10) is expected to provide flood mitigation to developed areas while reducing groundwater losses in Northeast Shark River Slough. The new pump station first became available in May 2009, and an interim operating plan including the new pump station was also approved. Unfortunately, downstream detention pond storage capacity has been insufficient to hold the captured water without creating additional flooding in the southwest corner of the 8.5-square-mile area, and the new pump station has ceased operation until additional detention storage as part of the C-111 South Dade project will be constructed.



FIGURE 3-10 The S-357 pump station, which began removing water from the 8.5-square-mile area on May 30, 2009.

SOURCE: USACE (2009c).

Decisions have not yet been made regarding plans for Mod Waters conveyance features along the L-67 levees, which were intended to move more water from WCA-3A through WCA-3B and ultimately through the existing S-355 structures in the L-29 levee into Northeast Shark River Slough. These features would restore some level of sheet flow in WCA-3B and reduce unnatural ponding of water in WCA-3A (see also Chapter 4). Planning for conveyance features in the L-67 levees could become part of the multi-agency process to develop a Combined Operating Plan, starting in January 2011, which would govern the operations of Mod Waters and C-111 South Dade project features. However, based on recent budgetary decisions, construction of these conveyance features is now uncertain (R. Johnson, NPS, personal communication, 2010).

Kissimmee River Restoration

The Kissimmee River was a meandering stream with an extensive flood plain draining into the northern edge of Lake Okeechobee (Figure 3-11). During the mid-to-late 20th century its channel was replaced with an artificially aligned channel that was hydrologically isolated from its flood plain (see also Chapter

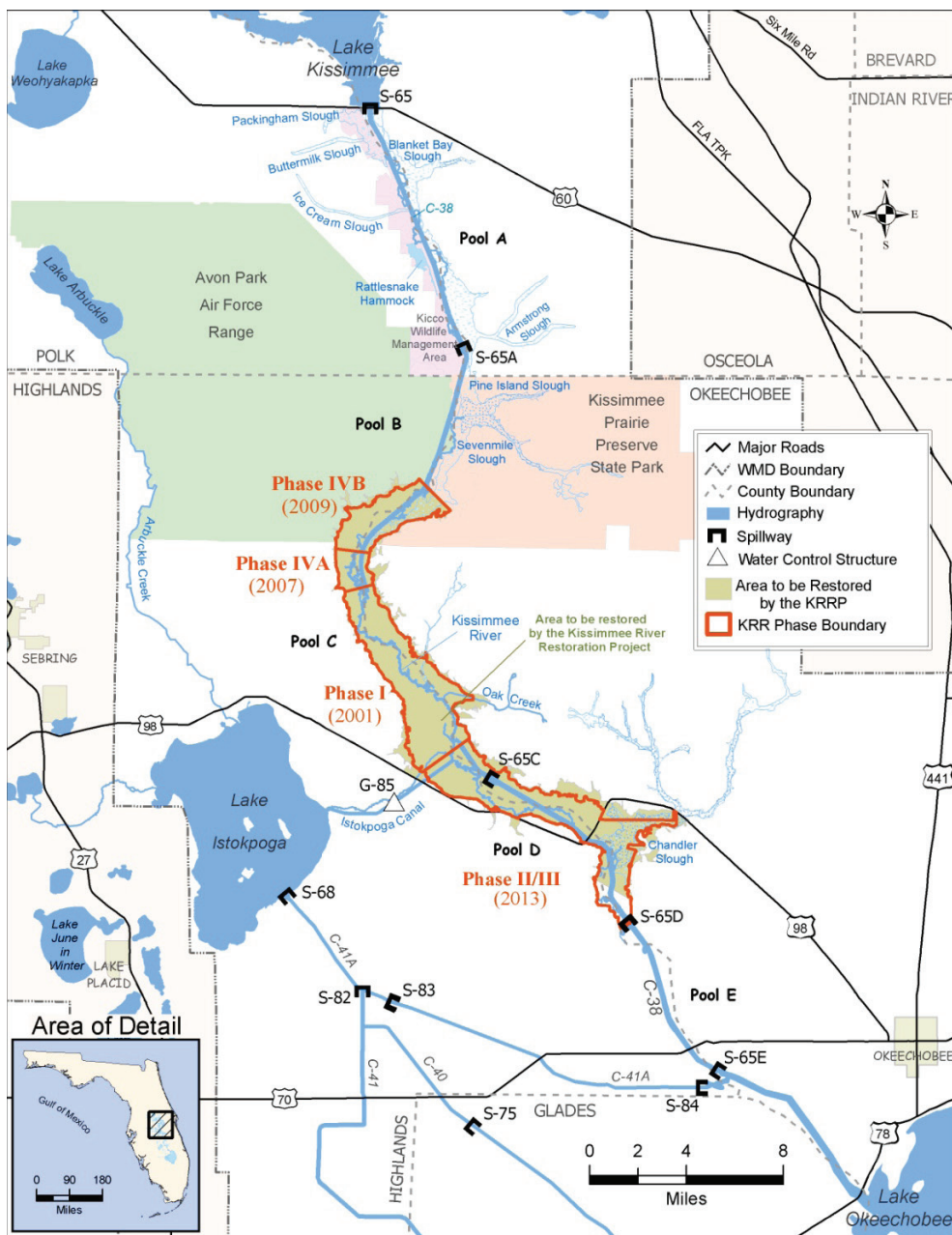

FIGURE 3-11 Phased construction zones in the Kissimmee River Restoration Project.

SOURCE: Jones et al. (2010).

2). The S-65 control structure (at the outlet of Lake Kissimmee) altered flows into the river from its upstream watershed, changing flow magnitudes, frequencies, durations, and timing. Restoration efforts include recarving 10 miles of the original river, backfilling 22 miles of channel, and changing the operation of the S-65 control structure so that flows into the river are more like natural flows that once occurred in the river.

The reconstruction of the river channel and the re-connection of its flood plain to the channel have progressed considerably since the project began in 1999 (Table 3-2, and Figure 3-11). The reconstruction originally was visualized in four sequential phases (I through IVA and IVB), but subsequent funding opportunities rearranged their order. Three of the project phases (I, IVA, and IVB) are now complete, with the last phase completed in 2010. As of 2010, about 60 percent of the overall project milestones have been achieved as measured by channel backfilled, river channel recarved, channel length with flow re-established, total flood plain area reconnected to the flow, and wetland area gained (see Table 3-2). The final combined Phases II and III will begin in 2011 and will be complete by 2013 (Jones et al., 2010).

Interim releases from the inflow gates for the Kissimmee River (S-65) have not yet provided all the expected ultimate benefits in flow characteristics or water quality. The full regulation schedule will not be implemented until 2013, and until that time, the USACE has authorized the SFWMD to make releases into the river when upstream lake levels are sufficient and the releases are not required for other purposes. The expected benefits are likely to be evident once the entire project is complete and the schedules of upstream releases into the river are in place. Low levels of dissolved oxygen, for example, are likely to improve once releases increase the discharge of the river during dry periods.

Restoration goals for flow in the Kissimmee River reflect characteristics that contribute to diverse and functional habitats, involving factors such as flow volume, temporal variability patterns, stage (depth), and velocities. Restoration has already achieved the objective of avoiding days when there is no flow in the river. Additional restoration goals include restoring substantial variability to flow magnitudes on two timescales: annual and monthly. At the annual scale, the objective has been to create a more natural pattern of flows with distinct high flows in the rainy season and lower flows in the dry part of the year. Managers have been successful in instituting this annual variation in regulated flows. Flow variation within shorter time segments of individual months, however, has not been restored to pre-drainage variability. Year-long trends in flow depths are producing over-bank flooding of floodplains for substantial periods each year, except during major droughts such as the 2006–2007 period, and floodplains are being functionally reconnected with channel flows. Velocities of flow in the channel are meeting target values about 85 percent of the time.

TABLE 3-2 Phased Construction of the Kissimmee River Restoration Project

Construction Sequence	Name of Construction Phase	Timeline	Backfilled Canal (miles)	River Channel Recarved (miles)	River Channel to Receive Reestablished Flow (miles)	Total area (acres)	Wetland Gained (acres)	Location and Other Notes		
1	Phase I project area	June 1989 - February 2001 (complete)	8	1	14	9,506	5,792	Most of Pool C, small section of lower Pool B		
2	Phase IVA project area	June 2006 - September 2007 (complete)	2	1	4	1,352	512	Upstream of Phase I in Pool B to Wier #1		
3	Phase IVB project area	June 2008 - February 2010 (projected)	4	4	6	4,183	1,406	Upstream of Phase IVA in Pool B (upper limit approximately at location of Wier #3)		
4	Phase IVIII project area	October 2011 - September 2013 (projected)	9	4	16	9,921	4,688	Downstream of Phase I (lower Pool C and Pool D south to the CSX Railroad bridge)		
Restoration Project Totals						22	10	40	24,963	12,398

SOURCE: Jones et al. (2010).

Water quality goals for restoration of the river focus on dissolved oxygen (DO) and total phosphorus (TP) in the stream. Expectations for two measures of DO (mean daily values and DO within 1 meter of the stream bottom) are yet to be met, and DO in the Kissimmee River is generally lower than in values in reference streams. Shallow water areas of the river, however, exhibit healthy levels of DO for fish, and as the restoration progresses, more such areas should become available. TP loads in the Kissimmee River vary widely with climatic conditions (e.g., lower TP loads in drought periods), but in general TP loads have not declined (Jones et al., 2010). As more floodplain areas become hydrologically connected to the river, TP levels may decline because of storage of phosphorus in floodplain ecosystems.

Wading birds and water fowl are also indicators of the general health of the Kissimmee River ecosystems. Nesting bird colonies have dramatically increased in numbers over the past two years, especially for cattle egrets and great egrets. Colonies for new residents such as tri-colored herons and white ibis have appeared in substantial numbers. Densities of wading birds have substantially increased since the initiation of the Kissimmee River restoration, and expected targets have been surpassed. Waterfowl densities also have increased, except during the exceptional drought years. Vegetation responses have also followed expected changes with the river restoration, with a near doubling of area of emergent vegetation compared to baseline data and a 66 percent reduction in floating and mat-forming vegetation (Bousquin et al., 2009). In sum, reasonable progress is being made in the restoration of the hydrology and geomorphology of the Kissimmee River, and the ecosystem has improved quickly in response to these changes. The Kissimmee River project results should be cause for cautious optimism that similar responses might be expected from the CERP.

Stormwater Treatment Areas

Since 1994, approximately 45,000 acres of STAs (effective treatment area) have been constructed in the Everglades Agricultural Area (see Figure 1-3) to remove excess phosphorus from surface waters before it enters the water conservation areas (WCAs) and Everglades National Park (also known as the Everglades Protection Area). As discussed in Chapter 5 in more detail, these STAs continue to remove large quantities of phosphorus from surface waters, although some have faced operation and maintenance challenges. However, since the last NRC report, a phosphorus “exceedance” as defined in the Consent Decree has been reported in the Arthur R. Marshall Loxahatchee National Wildlife Refuge (or WCA-1; SFWMD, 2009d), reflecting a violation of the Consent Decree. This exceedance reflected two sampling events (November 2008, June 2009) that

exceed the “long-term level” within 12 consecutive monthly samples.⁵ A plan to resolve these water quality issues is anticipated in September or October 2010, in response to recent court rulings.⁶

There is increasing recognition that the existing STA capacity is insufficient to treat the combined volumes and concentrations of phosphorus laden inflow. As of June 2010, construction of STA Compartments B and C is under way, which will add more than 11,000 acres of STAs (see Figure 5-6). Restoration planners anticipate that Compartment B, located west and south of STA-2, will enhance the performance of STA-2 by expanding its wetland treatment area. Compartment C, located between the existing boundaries of STA-5 and STA-6, is designed to expand the size and enhance the performance of these two STAs. Compartments B and C are expected to be flow-capable by the end of 2010, and construction should be completed by 2011 (Pietro et al., 2010). Nevertheless, these additional STAs do nothing to address the water quality violations in Loxahatchee, and additional treatment mechanisms and/or source controls are needed. See Chapter 5 for an in-depth discussion of water quality challenges in the Everglades restoration.

River of Grass

On June 24, 2008, Florida’s governor Charlie Crist announced that the SFWMD was going to enter into negotiations to acquire 187,000 acres of agricultural land from the U.S. Sugar Corporation for \$1.75 billion to maximize restoration opportunities for the South Florida ecosystem. Although not ideal as currently configured, these lands potentially offer the opportunity for additional water storage and treatment at a scale not previously envisioned in the CERP for the benefit of the Everglades ecosystem, Lake Okeechobee, and the St. Lucie and Caloosahatchee rivers and estuaries. Since the original announcement of

⁵For the refuge, water samples are collected monthly from fourteen interior marsh stations, and the geometric mean of total phosphorus is calculated. This geometric mean is compared to a target long-term level for that month which varies depending on water depth. If the mean is greater than the long-term level for that month, that is termed an excursion. If there are two or more excursions within twelve consecutive sampling events, that is termed an exceedance. An exceedance is a violation of the Consent Decree unless the Technical Oversight Committee (with one member from each of the five settling parties) determines the exceedance was due to error and/or extraordinary natural phenomena” (Kimball and Whisenant, 2008). The geometric mean concentrations in Loxahatchee National Wildlife Refuge were 13.2 ppb (compared to a long-term level of 12.1 ppb) in June 2009 and 7.4 ppb (compared to a long-term level of 7.2 ppb) in November 2008 (SFWMD, 2009c).

⁶The EPA released its Amended Determination in response to a judicial order on September 3, 2010. The state of Florida has 60 days following the Amended Determination to submit a plan containing alternate remedies. The committee did not review the amended determination in the preparation of this report. See *Miccosukee Tribe of Indians and Friends of the Everglades v. United States of America*, 04-21448-CIV-GOLD.

this “River of Grass” initiative, the SFWMD has negotiated several changes to the land purchase agreement. The SFWMD governing board in December 2008 voted to accept a proposal to acquire more than 180,000 acres of land for \$1.34 billion—a reduced price brokered by Governor Crist for a land-only acquisition. However, on April 2009 the two parties agreed to revise the contract because of the dramatic economic downturn and uncertain economic future. Under the April 2009 revised contract, the SFWMD would purchase 73,000 acres for \$536 million, and the U.S. Sugar Corporation offered an option to purchase the remaining 107,000 acres over the next 10 years.

The SFWMD identified numerous potential benefits from this land acquisition. Increased water storage in the Everglades Agricultural Area (EAA) would help reduce harmful freshwater discharges from Lake Okeechobee to Florida’s coastal rivers and estuaries, and this excess water could be treated and redistributed to the south, potentially providing increased water volumes to restore the southern Everglades. The lands could also be used to construct new STAs to help address current water quality concerns and improve the functionality of the current STAs. The options for managing Lake Okeechobee could also be improved, as harmful phosphorus flows would be prevented from entering the lake and the need for “back-pumping” water would be eliminated.

The SFWMD created a comprehensive public planning effort to facilitate stakeholder input and to build consensus on the design of the River of Grass initiative. During Phase I of this process (January to September 2009), the SFWMD held a series of workshops where nine working groups developed alternative configurations for constructing a managed system of water storage and treatment. All configurations proposed by the stakeholders contained storage, treatment, and conveyance project features using up to 180,000 acres without constraints regarding land swaps, but the approaches, restoration benefits, and costs differed widely among the groups’ proposed plans. Information generated during this first phase was intended to be utilized by the SFWMD governing board to support future planning and decision making related to the land acquisition.

In Phase II, which began in December 2009, the SFWMD used more extensive and detailed modeling tools to evaluate system performance and to consider constraints not previously examined. The hydrologic targets were also revisited in a series of science workshops to help refine the River of Grass storage needs. By the end of Phase II, the SFWMD intended to recommend approximately 2-4 design configuration alternatives and associated project footprints (with at least one scenario with land swaps and one without to account for the fact that not all of the U.S. Sugar Corporation lands are ideally suited for restoration purposes).⁷ However, Phase II has been halted (at least temporarily) to allow time for the

⁷See https://my.sfwmd.gov/portal/page/portal/common/newsr/rog_planning_2009_1218_new.pdf.

SFWMD to develop a plan to address several pressing legal issues concerning current water quality in Loxahatchee National Wildlife Refuge (LNWR) and the construction status of the EAA Reservoir.

On August 4, 2010, the SFWMD announced that the U.S. Sugar Corporation land purchase had been downsized again, considering the economic challenges facing the state of Florida. Under the latest agreement, the SFWMD would purchase 26,800 acres of land for approximately \$197 million in cash, while retaining the option to acquire more than 153,000 additional acres over the next 10 years (see Figure 3-12). This agreement sidesteps a current legal challenge to the state's right to use Certificates of Participation to finance the purchase, which was awaiting a decision by the Florida Supreme Court as of August 2010. The early acquisition represents 17,900 acres of citrus land in the C-139 basin, west of existing STAs 5 and 6, and 8,900 acres of sugarcane land northwest of LNWR—two areas with historically high phosphorus loads (SFWMD, 2010e).

Although no specific plans for the use of the lands have been announced as of August 2010, the SFWMD stated: "This acquisition, together with the Talisman lands, would give the District access to more than 50,000 acres of land south of Lake Okeechobee needed for project construction that will bring meaningful water quality and environmental improvements to the Everglades" (SFWMD, 2010e). These lands, perhaps with land swaps, could also help address recent violations of the Consent Decree. Yet, this represents only a small step toward the goals envisioned for the River of Grass initiative. Beyond this immediate acquisition, the future prospects for the River of Grass initiative and subsequent land acquisitions remain highly uncertain. The SFWMD developed an engaging planning process to examine a wide range of restoration projects that could be built using the U.S. Sugar Corporation lands and created an impressive set of data visualization tools to support the planning process. However, the availability of funding will be the limiting factor for additional land purchases that could be used to create additional water storage and to enhance the effectiveness of the CERP and the likelihood of reaching its goals. Additionally, it remains unclear how successfully other political and economic constraints can or will be addressed regarding the "option" lands (e.g., reality of land swaps, opportunity costs, stakeholder concerns) or how future River of Grass plans will be coordinated with the CERP.

Everglades Restoration Transition Plan

The USACE, with support from a multi-agency team, is leading a new initiative to examine operational flexibilities and improve water management within WCA-3 and Everglades National Park. This effort, called the Everglades Restoration Transition Plan, was necessitated by the pending expiration of

WCA-3A (see Chapter 4 for a discussion of water management in WCA-3A). With the pending expiration of the biological opinion on the IOP in November 2010, restoration managers saw the opportunity to improve upon the existing operational schedule for the benefit of multiple species, including the snail kite, wood stork, Cape Sable seaside sparrow, and tree islands, while maintaining the Central and South Florida project purposes.

The new operational plan needs to be in place by November 2010, and the team has had only approximately one year to review existing science and to evaluate potential strategies for improving water management within current constraints (e.g., no new structures, no impacts to water supply and flood control, water quality criteria). The changes under consideration are discussed in Chapter 4. The November 2010 deadline will limit the range of options that can be considered, because significant changes and any new structures would trigger a lengthy National Environmental Policy Act review. However, team members envision a continuing process, whereby the multi-agency team could continue to improve the operation schedule over time based on new information to maximize benefits for multiple species sooner rather than later, while awaiting further structural improvements through the CERP. The committee commends the restoration team for this initiative to expedite restoration progress (see also Chapter 4).

PROGRAMMATIC PROGRESS

In the first 10 years of the CERP, progress was primarily programmatic, with the development of an institutional structure and guidance to support CERP planning and adaptive management, which laid the groundwork for the construction progress now under way. Many of the programmatic challenges noted in NRC (2008) still remain, including the complex project planning and approval process required for federal funding. However, some improvements have occurred over the past two years, including agreement on a new integrated schedule for the restoration, adoption of a “master agreement” between the state of Florida and the federal government to address some long-standing procedural constraints, and increasing federal restoration funding. These and other programmatic issues are discussed in the following sections.

Project Scheduling

In response to advice from the Government Accountability Office (2007) and NRC (2007), CERP planners worked for more than a year to develop a revised project implementation schedule for the South Florida ecosystem restoration, termed the “Integrated Delivery Schedule” (IDS; Figure 3-13). In the IDS, the

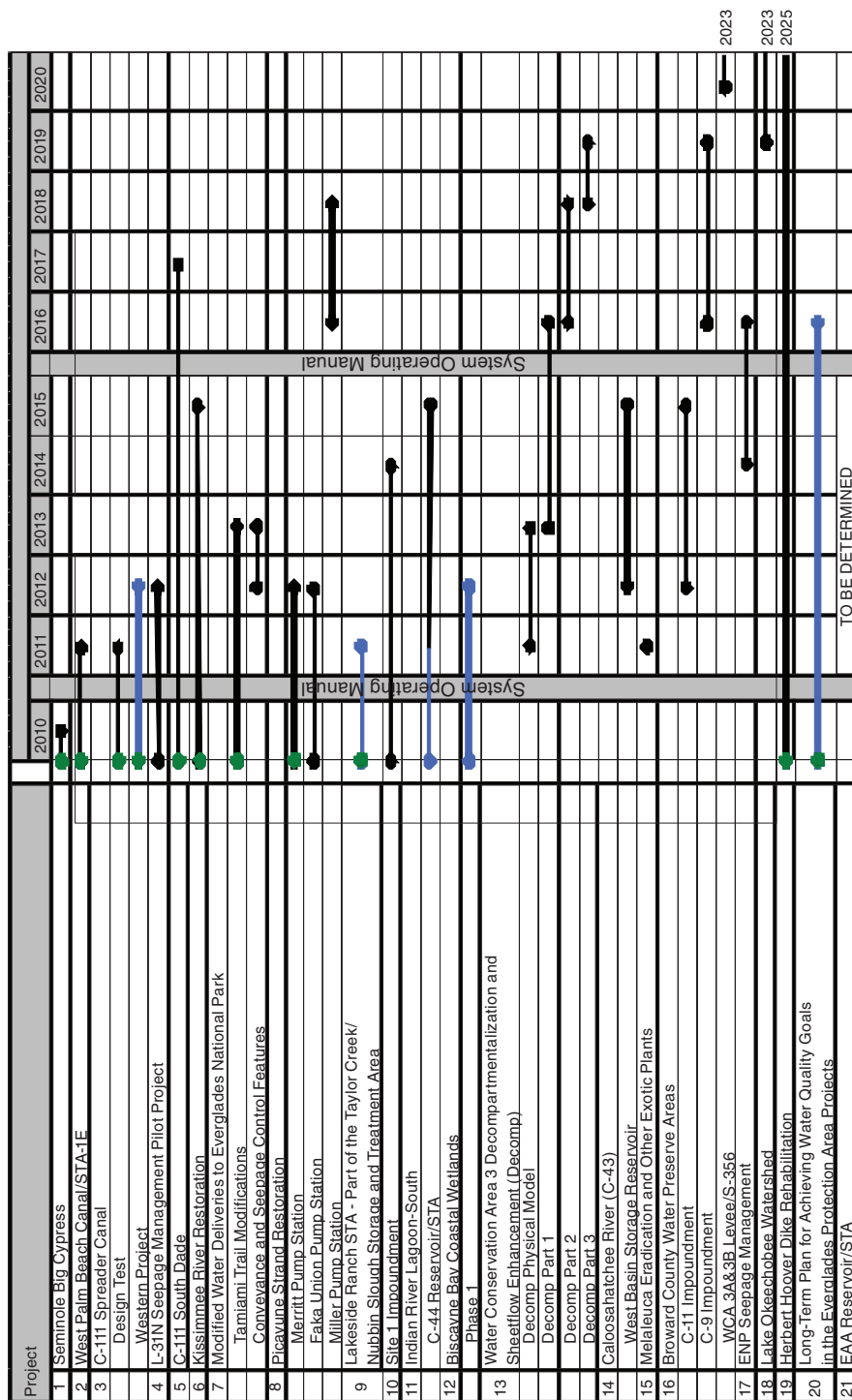

● Projects are currently federal construction.
 ● Projects are currently non-federal construction, subject to change based on funding allocation.
 ● Construction has started on these projects.

8 March 2010

FIGURE 3-13 Integrated Delivery Schedule, March 2010 draft.

SOURCE: L. Gerry, SFWMD, personal communication, 2010.

USACE and the SFWMD, in consultation with numerous stakeholders, reprioritized the timing of future restoration activities according to anticipated funding streams, although it is envisioned to be a living document that will be updated as needed. The IDS replaces the Master Implementation Sequencing Plan (MISP) for CERP projects, which was last updated in 2005.

Workshops were held with the South Florida Ecosystem Restoration Task Force (Task Force) and the Working Group to help build consensus on the new schedule. The guiding principles for the planning process emphasized the need to deliver restoration benefits at the “earliest practicable time,” consistent with recommendations of NRC (2007), and recognized the importance of supporting ongoing commitments to key non-CERP projects that contribute to the success of the CERP (Appelbaum, 2008). A description of the development process and rationale for the IDS was released in June 2010, but the document does not include justification for specific sequencing decisions. The “leaflet” explains that the IDS uses a “hybrid approach” that starts with CERP and non-CERP projects that are already authorized or otherwise committed, and adjusts the schedule, pulling some non-authorized projects forward or pushing other authorized projects back based on their ability to deliver “meaningful restoration benefits as early as possible” (USACE, 2010b). CERP planners state that the IDS represents the “optimum sequence for implementation of South Florida ecosystem restoration projects” consistent with incremental adaptive restoration as proposed by the NRC (2007), construction authority, and available funding (USACE, 2010b). The IDS is updated every few months to reflect changes in funding, project implementation progress, and changes in prioritization, and the March 2010 version is shown in Figure 3-13. The IDS shows that a large number of CERP projects are being pushed back beyond the 2020 timeframe. However, Appelbaum (2008) noted that “no CERP projects are being taken off the table.”

The near-term IDS (as of March 2010) includes several pre-CERP and CERP projects—specifically Mod Waters, C-111 (South Dade), and Decomp—that have the potential to significantly alter the distribution and timing of water flows through the WCAs and into Everglades National Park. These projects have repeatedly been identified as highest priority for reversing ecosystem decline and progressing toward ecological restoration of the remnant Everglades (e.g., Ad Hoc Senior Scientists, 2007). However, their benefits cannot be fully realized without provision of additional water, which will require addressing water quality issues and providing significant new storage. As discussed in the next two chapters, even allowing for the completion of the stalled EAA Reservoir, until larger volumes of clean water are made available, water managers will face ecological tradeoffs among subregions of the WCAs and Everglades National Park. Increased water storage in the EAA and in the northern Everglades will almost certainly become a high priority in the years ahead.

Revisions to the Programmatic Regulations

The Programmatic Regulations established a procedural framework and set specific requirements that guide the implementation of the CERP to ensure that the goals and purposes of the CERP are achieved. The Programmatic Regulations were promulgated in 2003 and were slated to undergo a five-year review in 2008. This review provided an opportunity for the USACE to propose revisions that could improve the project planning and evaluation process and to address some of the procedural impediments identified in NRC (2008). However, little apparent progress has been made on proposed revisions, even though this represents an important opportunity to enhance future planning progress.

Master Agreement

A significant programmatic accomplishment of the restoration organizations has been a “master agreement” signed on August 13, 2009, by the Department of the Army and the South Florida Water Management District. The agreement was intended to promote cooperation between the two agencies for construction, operation, maintenance, and repair of CERP projects.

In addition to specifying a common terminology for projects, the agreement provided for financial sharing of CERP obligations. Consistent with the original CERP agreement, the federal government and the SFWMD agreed to have a 50:50 cost share of CERP construction. The Master Agreement specifies reporting, allowable scope for the joint responsibility, and processes to provide accounting for this cost sharing. For example, monitoring performed during the construction of a CERP project is allowed within the construction expense. Similarly, expenses incurred for land acquisition can be included in allowable construction expenses and a process for valuing such acquisitions is specified, settling previous long-standing disagreements. Methods of payment and valuation of in-kind services are also specified. However, the actual expenditures by the federal government still depend upon project authorizations and appropriations enacted by Congress.

Coordination of project management activities is also required by the Master Agreement. The agencies agreed to share budget and cost information, schedules, and quality assurance and quality control. As CERP projects are completed and enter into operation, expenses for operations, maintenance, repair, and renovation are also to be shared equally as long as federal funds are available.

As CERP projects enter into more active construction phases, the existence of the Master Agreement provisions should smooth the processes of project management, budgeting, and scheduling. As a result, coordination between the USACE and the SFWMD should be enhanced.

Funding

Florida state funding for Everglades restoration peaked at \$800 million in fiscal year (FY) 2007 with activity on state expedited projects, previously known as Acceler8 (Figure 3-14). With the economic recession and negotiations for the U.S. Sugar Corporation land acquisition, funding levels dropped in 2008-2009. In the FY 2010 budget adopted in October 2009, the SFWMD plans funding of \$1.1 billion for Everglades restoration (CERP and non-CERP), representing a significant increase, although included in this budget was \$536 million in Certificates of Participation for the acquisition of 73,000 acres of U.S. Sugar Corporation land (SFWMD, 2009c) that has now been downscaled to \$197 million. Thus, even though the budget appears to be a sizeable increase in investment, it reflects a major decrease in funding for existing restoration programs compared to prior years. According to the draft Task Force cross-cut budget (K. Berger, SFERTF, personal communication, 2010), anticipated state funding for CERP projects declined to \$146 million in FY 2010, a level that is less than

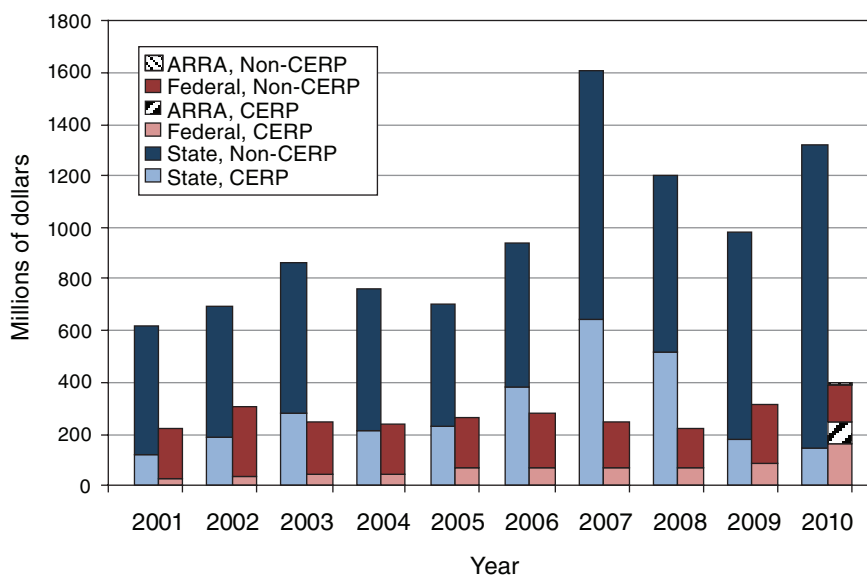

FIGURE 3-14 Federal and state Everglades restoration funding amounts including CERP and non-CERP activities (enacted 2001-2009 and requested 2010). ARRA funding reflects funding enacted as of September 2010.

SOURCE: Data from SFERTF cross-cut budget (2010); K. Berger, SFERTF, personal communication, 2010.

federal CERP funding for the first time since the launch of the CERP. This budget stress has also caused the state to scale back on its expedited project initiatives.

Federal funding for Everglades restoration has long trailed funding from the state of Florida. Because of the lack of congressional authorizations for CERP project construction prior to 2007 and to address the large backload of unfinished non-CERP foundation projects that are essential to restoration, most of the federal funding has been concentrated on non-CERP projects (e.g., Kissimmee River Restoration, Mod Waters). But in the past two years, the federal government has substantially increased funding for Everglades restoration, including CERP and non-CERP projects (see Figure 3-14). In FY 2010, the USACE received \$180 million for South Florida ecosystem restoration (USACE budget only), representing nearly 10 percent of the agency's civil works construction budget (\$2.03 billion). The federal government also provided nearly \$88 million in American Recovery and Reinvestment Act (ARRA, or economic stimulus) funding for CERP projects over FY 2009 and 2010, and an additional \$7.5 million for non-CERP projects (M. Magley, USACE, personal communication, 2010).

This recent increase in federal spending has created a new programmatic hurdle related to CERP federal-state (50:50) cost sharing. To qualify for federal cost sharing, non-federal CERP expenditures must be formally "credited" or certified. Before the crediting process can begin, a project must be authorized by Congress and have a signed project partnership agreement (PPA), which reflects the legal and technical design agreements between the federal and state sponsor related to project construction. The USACE is prohibited from exceeding the overall credited expenditures from non-federal partners at any time, and federal funding would be halted before it exceeded non-federal credited expenditures. As shown in Figure 3-14, prior state CERP expenditures have greatly exceeded federal expenditures, but many of these expenditures (e.g., land acquisition, construction work on expedited projects) have not yet been credited. PPAs recently signed for the Site 1 Impoundment and the Indian River Lagoon-South (IRL-S) projects provide enough credited expenditures to allow continued federal funding (at the current pace) through approximately 2014. Continued project authorizations, however, are needed to prevent a halt in federal funding for the CERP after this date (E. Bush, USACE, personal communication, 2010).

Rehabilitation of the Herbert Hoover Dike also represent a substantial portion of the overall USACE budget. In 2008 and 2009, respectively, \$55 million and \$74 million were appropriated in the USACE Jacksonville District budget for rehabilitation of the dike, and \$123 million was appropriated in FY 2010 (SFERTF, 2009; H.R. 3183 Conference Report). The construction efforts are required to maintain the safety and stability of the dike and should not be considered part of the South Florida ecosystem restoration funding; therefore, they are not included in Figure 3-14. The estimated financial requirement for

the entire Herbert Hoover Dike rehabilitation effort is estimated to be \$1 billion (SFERTF, 2009). It remains uncertain whether the political will can remain to support continued large federal expenditures for the Florida USACE budget. Continued support for federal funding of Everglades restoration projects is critical to maintain the momentum and create near-term restoration benefits. The Task Force tracks and compiles expenditures and financial requirements for all South Florida restoration projects as reported by the sponsoring agencies in the annual Integrated Financial Plan (SFERTF, 2009). The estimated financial requirements and expenditures through FY 2009 for different categories of CERP projects are shown in Table 3-3. The largest expenditures have been for surface-water storage, natural area habitat restoration, and other related hydrology projects. Of an estimated \$13 billion in financial requirements for CERP projects, only 2 percent has been spent through FY 2009, leaving financial requirements of more than \$12 billion. More progress on CERP projects is expected in the future as CERP precursor projects are completed.

In 2004, the estimated cost of CERP was \$11 billion (DOI and USACE, 2005), which was to be split equally between the federal and state governments. Five years later, the Task Force (SFERTF, 2009) made an estimate of \$12.8 billion to adjust for inflation and any approved changes to project designs; thus, the 50 percent federal share is now estimated at \$6.4 billion. This total does not include expenditures on non-CERP projects. Moreover, this CERP total is likely to grow

TABLE 3-3 Total Estimated Financial Requirements for the CERP and Funds Expended Through FY 2009 (in 2008 Dollars)

Category of CERP Project	Financial Requirement (\$ Million)	Funds Appropriated Through FY09 (\$ Million)
Surface water storage	7,338	89
Alternative water storage	2,176	13
Modify impediments to sheet flow	364	11
Other related hydrology projects	358	54
Stormwater treatment areas and water quality	216	1
Natural area habitat restoration	1,274	69
Water reuse	1,100	2
Sum of categories	12,826	239

NOTE: This table does not include expenditures for program level activities (including monitoring and assessment) or land purchases that have not yet been credited. Also, only SFWMD expenditures through FY07 are included.

SOURCE: SFERTF, 2009; A. Murphy, USACE, personal communication, 2010.

with inflation over time. At a continued funding rate of \$200 million per year for CERP projects (with funding increasing with inflation at the same rate as construction costs), the federal portion of the CERP would be fully funded in roughly 32 years. With increased annual federal expenditures on CERP or a scaled-back CERP plan, this timeframe would be shorter. Conversely, increased costs would lengthen this timeframe. Fiscal constraints dictate a long-term approach over a period of multiple decades for completion of CERP.

The CERP was expected to take several decades to complete, but the pace of restoration over the past decade suggests 40–60 years as a more realistic timeframe. Political and financial support for Everglades restoration will certainly erode steadily over such a long time in the face of so many competing needs for public funding unless tangible ecological and public benefits can be demonstrated through CERP monitoring and assessment activities.

CONCLUSIONS AND RECOMMENDATIONS

During the past two years the restoration program has made tangible progress, and four CERP projects are now under construction. Continued federal commitment is especially important at this time. The Everglades restoration program has completed the arduous federal planning and authorization processes for three projects and is now moving forward with construction of the Picayune Strand project with federal funding. Additionally, despite budget challenges, the state of Florida continues to expedite the construction of three projects (C-111 Spreader Canal, Biscayne Bay Coastal Wetlands, and Lakeside Ranch STA). After years of delay, it is critically important to maintain this momentum to minimize further degradation of the system during CERP implementation.

Some restoration benefits can be attributed to partial restoration of Picayune Strand; however, the completion of additional ongoing and planned projects will be required to see substantial restoration benefits for the Everglades ecosystem. The SWFMD (Williams et al., 2010) reports that plugging one canal in Picayune Strand raised water tables on approximately 13,000 acres of adjacent wetlands, representing partial hydrologic restoration on approximately one-fourth of the project area. Construction is also under way on the C-111 Spreader Canal and the Biscayne Bay Coastal Wetlands projects, but no significant restoration benefits have yet resulted from these efforts. Each of these projects is being implemented in phases to deliver early restoration benefits when possible with available funding.

Pilot projects and field-scale experiments are addressing some important design uncertainties but could be better linked to decision making and implementation. In addition to the originally conceived CERP pilot projects, CERP planners have recently initiated two field-scale experiments (the C-111 Spreader

Canal design test and the Decomp Physical Model [DPM]). These projects are intended to reduce design uncertainties that were points of contention among stakeholders, which limited progress on project planning. The C-111 design test will address important hydrologic uncertainties; additional pilot components are needed to address the potential impacts of elevated nutrients on receiving wetlands. The DPM will produce the most detailed observation data to date on the hydrology and ecology of sheet flow in the ridge and slough system. Nevertheless, limited replication and the two-year duration limit the statistical power of the experiment. The DPM will provide information on hydraulic, hydrologic, and short-term ecological differences between canal backfilling options and will improve understanding of the hydrologic response of WCA-3B to re-watering, but the experiment will likely require additional replication to settle the current debate over the efficacy of different canal treatments. CERP scientists and planners should consider other means of synthesizing and communicating results beyond traditional hypothesis tests to facilitate stakeholder discussions and decision making under uncertainty.

Aquifer storage and recovery (ASR) pilot studies have contributed valuable hydrogeologic and geochemical information, but the administrative delays, site limitations, funding constraints, and arsenic leaching encountered are indicative of serious challenges facing large-scale use of ASR. The final ASR pilot report should address the impacts of these factors on use of ASR at the unprecedented scale envisioned for the CERP and should compare the long-term costs and benefits of ASR against other less energy-intensive storage alternatives.

Initiation of construction of a 1-mile bridge on the Tamiami Trail is an important, albeit partial, step forward. NRC (2008) called the Mod Waters project, of which the bridge is one component, “one of the most discouraging stories in Everglades restoration,” and stated that if the downsized 1-mile bridge could not be built, the outlook for the CERP was dismal. With leadership from the administration and Congress, the federal government was able to overcome numerous obstacles to ultimately break ground on the project in December 2009. Although the benefits derived from the 1-mile bridge represent only a fraction of those envisioned in earlier Mod Waters plans, planning is under way to consider additional bridging that could take advantage of a downturn in construction costs.

The River of Grass initiative could create options for additional water storage and water quality treatment to help meet CERP objectives. The SFWMD governing board recently approved the purchase of nearly 27,000 acres of U.S. Sugar Corporation lands—substantially less than what was previously announced—near areas with historically high phosphorus loads. These lands could help the SFWMD come into compliance with current water quality requirements, yet this represents only a small step toward the goals of the River

of Grass initiative. Prior to this announcement, the SFWMD had facilitated an engaging and inclusive River of Grass planning process and created an impressive set of data visualization tools to support the effort. As of mid-2010, the specific benefits that will accrue to the CERP from the River of Grass initiative cannot be determined, because the planning and design process has not been completed and the availability of funding to support future land purchases is unknown. Also, it remains unclear how successfully other political and economic constraints can or will be addressed for the remaining “option” lands (e.g., reality of land swaps, opportunity costs, stakeholder concerns) and how the initiative will be coordinated with the CERP.

Given the slower-than-anticipated pace of implementation and unreliable funding schedule, projects should be scheduled with the aim of achieving substantial restoration benefits as soon as possible. The latest Integrated Delivery Schedule appears consistent with this goal and should generate substantial restoration benefits by 2020. Although many projects have been delayed, aggressive schedules have been maintained (as of the March 2010 IDS) for the Decomp project, seepage management, and critical foundation projects. These projects offer significant restoration benefits to the remnant Everglades ecosystem, but the benefits cannot be fully realized without the provision of additional water, which will require substantial new storage and associated water quality treatment.

Maintaining political and public support for Everglades restoration will be critical to future CERP progress. Multiple decades of sustained commitment and a high level of public funding will be needed to complete the CERP. Maintaining this commitment will be a continuing challenge, and early, demonstrable public and ecological benefits from restoration activities are keys to retaining public support.

4

Challenges in Restoring Water Timing, Flow, and Distribution

As discussed in Chapter 2, Everglades restoration is premised on “getting the water right” by striving to reestablish the quality, flow, timing, and distribution of freshwater that characterized pre-drainage South Florida ecosystems. Addressing the disparate hydrological requirements of the diverse wetland communities that comprise the greater Everglades ecosystem demands highly integrated water resource planning and adaptive re-engineering and re-operating of the Central and South Florida (C&SF) Project.

Restoration at this scale involves many uncertainties, constraints, and tradeoffs. In the next two chapters, short-term priorities and longer-term plans for restoring surface flows and water quality are examined. The discussion of surface hydrology in this chapter focuses on the kinds of tradeoffs that are, of necessity, being made in re-distributing water to different parts of the Everglades, and considers the risks associated with incomplete restoration or long delays in providing storage capacity and additional water. The committee focused special attention on Water Conservation Area (WCA) 3 as an example of these challenges because it serves as the main flow-way of water through the remnant Everglades. WCA-3 provides habitat for important Everglades species and system features, and it is a nexus for many contentious Everglades water flow issues. Also, flows in Everglades National Park and WCA-3 are interdependent because of their adjacent geographic locations. Current water quality concerns and regulations, the cost and performance of source control and treatment alternatives, and the considerable technical and economic challenges of bringing existing and planned Comprehensive Everglades Restoration Plan (CERP) flows into compliance are summarized in Chapter 5.

PAST AND FUTURE CHANGES TO SOUTH FLORIDA'S WATER BUDGETS AND FLOW REGIMES

The hydrologic result of the Central & South Florida Project in the Everglades portion of the drainage basin south of Lake Okeechobee was a near-total

transformation of the flow system (USACE and SFWMD, 1999). The impacts of these changes to the landscape and the ecosystem are described in detail in Chapter 2, but the quantitative changes in hydrology are discussed further in this section to provide a basis for additional discussion of improving water flow and distribution.

A comparison between pre- and post-drainage water budgets of the Kissimmee-Okeechobee-Everglades watershed (Figures 4-1 and 4-2) shows how the distributions of water storage and transfers are believed to have changed. Some of the key features of these modeled water budgets are summarized in Table 4-1 according to Natural Systems Model (NSM) version 4.6.2 and the South Florida Water Management Model (SFWMM) version 5.4 (see Box 4-1). Comparable water budgets based on the newer South Florida Regional Simulation Model (RSM) are not yet possible because of model development issues discussed in Chapter 6. The water budget models have considerable uncertainty associated with estimating evapotranspiration and specific values of water flows from one compartment to another, and the models are used here as generalizations rather than as exact accountings.

According to the SFWMM, on average Lake Okeechobee discharges approximately 11 percent less water south under current conditions (554,000 acre-feet/year) compared to pre-drainage flows (622,000 acre-feet/year; see Figures 4-1 and 4-2). Total inflow to the WCAs ranges widely with the models used. The SFWMM v. 5.4 calculates that current water inflows from the north to the WCAs (1.3 million acre-feet [MAF]/year) exceed that which would have occurred via sheet flow in the pre-drainage system (1.06 MAF per year; NSM v. 4.6.2). However, the new Natural System Regional Simulation Model (NSRSM) depicts a wetter pre-drainage Everglades in which 1.5 MAF flowed from Lake Okeechobee into what is now the Everglades Agricultural Area (EAA) and at least 1.7 MAF flowed from the north into the current WCAs, across their northern boundaries (J. Obeysekera, SFWMD, personal communication, 2009).

Roughly 1.9 MAF per year still enters the WCAs across the western, northern, and eastern boundaries under current conditions (see Figure 4-2), but inflow now occurs primarily through canal or stormwater treatment area (STA) discharges, unlike in pre-drainage conditions when direct precipitation and occasional overflows from Lake Okeechobee dominated freshwater inputs (Harvey and McCormick, 2009). Surface-groundwater exchanges were minimal in the relatively flat, peat-covered, pre-drainage landscape. In contrast, peat subsidence, canals, and levees have created local hydraulic gradients that increase seepage and surface-groundwater interactions. As a result, after losses by evaporation, the WCAs now lose nearly half their remaining water through seepage to coastal areas. In addition, the loss of peat through oxidation has accentuated groundwater losses by permitting movement of surface water downward. The thick

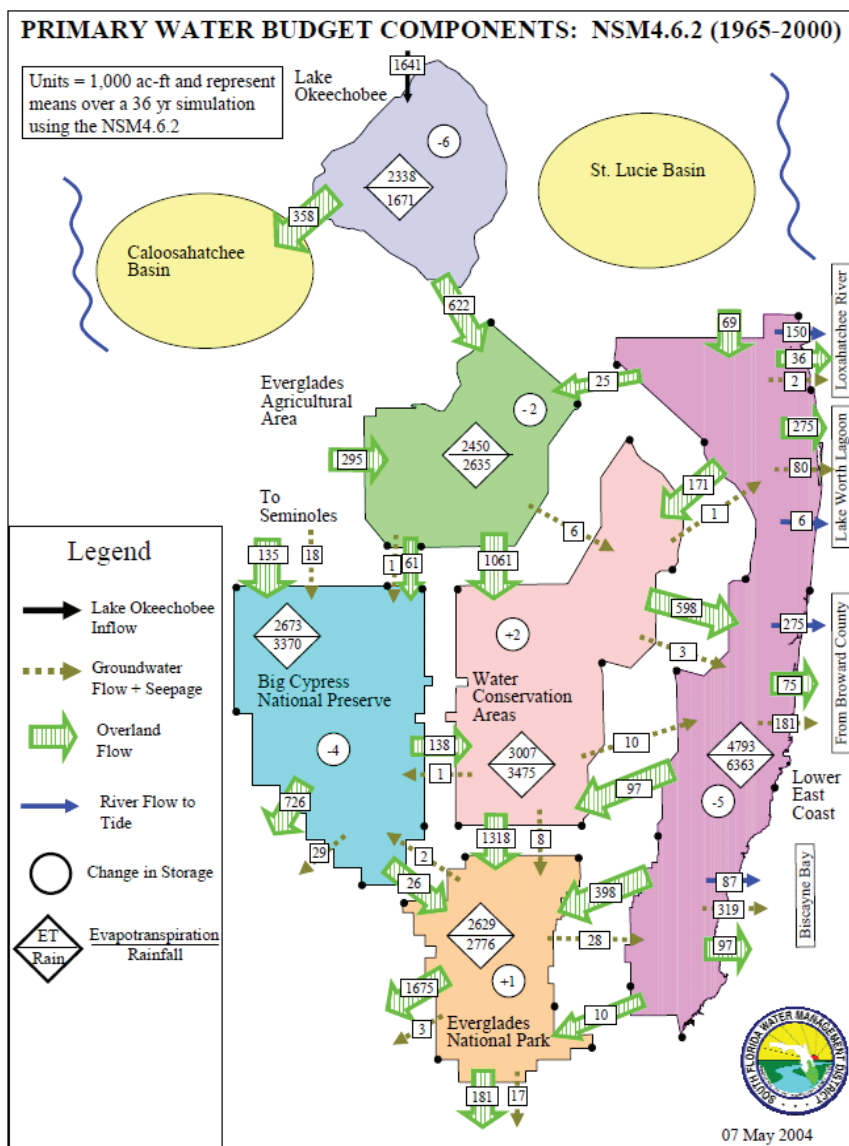

FIGURE 4-1 Estimated annual water budget for the Kissimmee-Okeechobee-Everglades drainage basin, 1965–2000, under pre-drainage and pre-development conditions, calculated using the Natural System Model (NSM) version 4.6.2, which simulates regional hydrology in the absence of existing control structures. The numbers in rectangles represent mean annual flow volumes in 1,000 acre-feet/year, based on model simulations using a 36-year precipitation data set. Change in storage, shown in circles, represents the net inflows minus outflows over the period of record.

SOURCE: J. Obeysekera, SFWMD, personal communication, 2009.

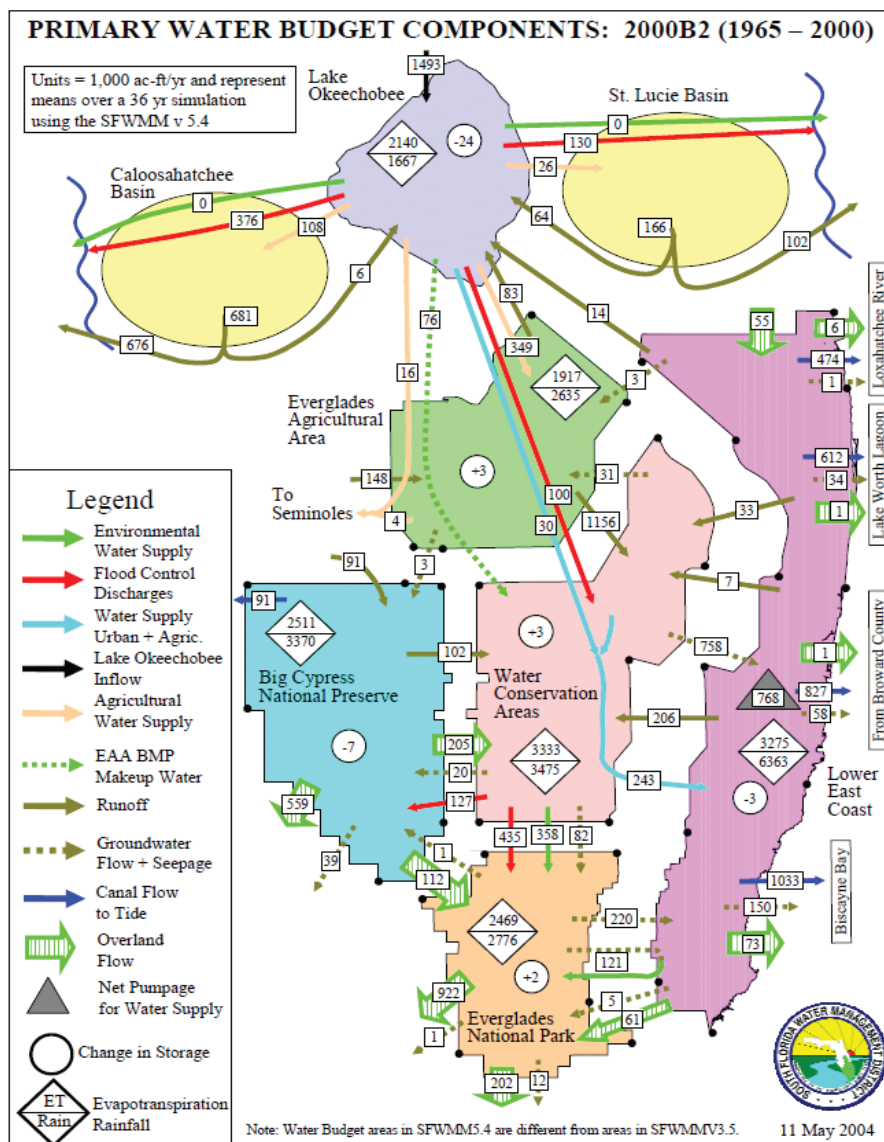

FIGURE 4-2 Estimated annual water budget for the Kissimmee-Okeechobee-Everglades drainage basin under post-drainage and post-development conditions, calculated using a 36-year simulation using the SFWMM with structures in place as of 2000 (usually considered the typical “current” situation). The numbers in rectangles represent mean annual flow volumes in 1,000 acre-feet/year, based on model simulations using a 36-year precipitation data set. Change in storage, shown in circles, represents the net inflows minus outflows over the period of record.

SOURCE: J. Obeysekera, SFWMD, personal communication, 2009.

TABLE 4-1 Total Flow Volume of Freshwater Inputs and Outflows from Four of the Regions Shown in Figures 4-1, 4-2, and 4-5

		Pre-drainage (KAF)			Total
		Precip./ET	Surface water	Groundwater	
Lake Okeechobee	Inputs	1,671	1,641	0	3,312
	Outflows	2,338	980	0	3,318
Everglades Agricultural Area	Inputs	2,635	942	0	3,577
	Outflows	2,450	1,122	7	3,579
Water Conservation Areas	Inputs	3,475	1,467	6	4,948
	Outflows	3,007	1,916	23	4,946
Everglades National Park	Inputs	2,776	1,752	8	4,536
	Outflows	2,629	1,856	50	4,535

NOTE: The numbers represent total inflows and outflows calculated using the data provided in the figures, which were generated by the NSM v. 4.6.2 and the SFWMM v. 5.4. ET = evapotranspiration; KAF = thousand acre feet.

peats of the pre-drainage system isolated the surface water from the groundwater. These changes also have important implications for water chemistry, as will be discussed in Chapter 5. Everglades National Park has also experienced substantial changes in flows as a result of the engineered systems upstream. Under the pre-drainage conditions, the area that is now Everglades National Park received roughly 1.3 MAF of water per year (according to both the NSM and the NSRSM) as overland sheet flows from the land that is now WCA 3, with total inflow of 1.7-1.8 MAF from all sources (Figure 4-1). Under present conditions the same park area receives about 0.8 MAF in surface flows from WCA-3 through culverts beneath Tamiami Trail (Figure 4-2). On average 1.1 MAF flows into the park from all sources (or 61-64 percent of pre-drainage flows), and seepage to the east removes an additional 0.2 MAF of this total. As a result of these adjustments, the park area that once discharged approximately 1.9 MAF per year through coastal ecosystems to the Gulf of Mexico (NSM 4.6.2; or 2.1 MAF per year according to the NSRSM) now only discharges about 1.1 MAF per year (see Figures 4-1 and 4-2).

In addition to changes in the overall volume and distribution of water discussed above, the Everglades landscape has also experienced substantial changes in the timing, duration, velocities, and directions of flow. Although no stage data for South Florida exist prior to the construction of the Tamiami Trail and associated levees, hydroperiods historically were thought to be tied to seasonal variation in regional rainfall and secondarily to the slow drainage into and from the region (Duever et al., 1994). Florida has a five-month "rainy season" (mid-May to mid-

Current (KAF)				CERP flows (KAF)			
Precip./ET	Surface water	Groundwater	Total	Precip./ET	Surface water	Groundwater	Total
1,667	1,660	0	3,327	1,667	1,820	0	3,487
2,140	1,211	0	3,351	2,130	1,374	0	3,504
2,635	497	34	3,166	2,635	614	26	3,275
1,917	1,243	3	3,163	2,025	1,244	3	3,272
3,475	1,915	0	5,390	3,475	1,899	0	5,374
3,333	1,163	891	5,387	3,301	1,485	592	5,378
2,776	1,087	87	3,950	2,776	1,898	5	4,679
2,469	1,124	355	3,948	2,572	1,597	503	4,672

October) that is typically accompanied by increasing water levels, and a less rainy or “dry season” (November to April) that is typically associated with stable or falling levels (Obeysekera et al., 1999). The reproductive success and survival of Everglades flora and fauna are linked to these seasonal cycles. For example, many wetland species such as apple snails, alligators, wading birds, snail kites, and Cape Sable seaside sparrows time breeding to coincide with the dry season, expecting water levels to recede slowly. Yet the area still receives significant rainfall in the dry season associated mainly with frontal passages, and that rain can lead to rising rather than falling water levels (i.e., “reversals”), which can result in reduced reproductive success for many wetland birds (discussed in more detail later in the chapter). Reversals during spring likely occurred in the pre-drainage Everglades, but two factors probably have increased their frequency and magnitude recently. The first is the reduced water-storage and hydrologic buffering capacity associated with the reduced spatial extent of the Everglades. The second is current water management, which can contribute to increased annual changes in water levels, as has occurred on Lake Okeechobee (Beissinger, 1986; NRC, 2007). While the Everglades has been described by some as a “hyperseasonal savanna” (Kushlan, 1987; Duever et al., 1994), its inter-annual (between-year) rainfall variation actually is much smaller than that of other lowland neotropical wetlands with similar flora and fauna (Beissinger and Gibbs, 1993), such as the Llanos in Venezuela and the Pantanal in Brazil (Kushlan et al., 1985). Thus management activities that increase intra-annual (within-year) variation in water levels will likely adversely affect the Everglades.

BOX 4-1**Modeling the Hydrology of the Historic South Florida Ecosystem**

An understanding of the water flows of the pre-drainage system is essential for restoration project planning. Comprehensive Everglades Restoration Plan (CERP) agencies presently use two models to estimate pre-drainage water flows: the Natural System Model (NSM) and the Natural System Regional Simulation Model (NSRSM). These models use similar platforms as hydrologic models of current conditions but without the water control infrastructure and with different land cover and land use. The NSM uses the same climatic input, model parameters, grid spacing (2 mile by 2 mile) and computational methods as the South Florida Water Management Model (SFWMM), but physical features, such as topography, vegetation type, and river locations are adjusted to represent the pre-drainage condition. As more paleoecology data became available that provided important insights into historic hydrologic conditions (e.g., Willard et al., 2001; Winkler et al., 2001; Saunders et al., 2006; Bernhardt and Willard, 2009), the NSM progressed through a series of revisions. Version 4.6.2 is the latest version of the model in use, although Everglades National Park has worked on its own revisions to the model code (called ENP Mod 1) based on paleoecology data that were not well simulated in prior versions of the NSM. ENP Mod1 simulates a much wetter system than that of NSM 4.6.2.

The NSRSM is an entirely new fully coupled surface-groundwater model with a system of triangular cells ranging in size from 0.1 to 2 miles on a side. Compared with earlier modeling efforts for the pre-drainage system, the NSRSM covers a larger proportion of the entire watershed (and some areas outside the watershed), and it uses improved data sets, particularly for land cover and land use and topography. The South Florida Water Management District (SFWMD) is currently developing the South Florida Regional Simulation Model (RSM) designed to extend the NSRSM to describe present conditions. Generally, NSRSM model runs describe a natural system that is wetter than the system described by NSM 4.6.2 model runs.

These three model-generated descriptions of the pre-drainage system are each different, and there is uncertainty inherent in such hind-casts of hydrologic conditions of a century ago. Despite these reservations, the committee sees some convergence among the recent pre-drainage model output (NSRSM, ENP mod1) suggesting a wetter pre-drainage system than prior NSM output, with total inputs from the north to the current Everglades Protection Area averaging 1.9-2.1 million acre-feet (MAF)/year. This amount can be contrasted against current flows of approximately 1.4 MAF/year across the same boundaries (Wilcox and McVoy, 2009).

The inter-annual variation of flood and drought events is another important feature of the pre-drainage Everglades. Floods and droughts are recurring pulse events in many wetlands (Odum et al., 1995; Dong, 2006) including the Everglades (Thomas, 1974). The life histories of many plants and animals have evolved and been shaped in the Everglades by these hydrologic events (Davis and Ogden, 1994), which may have occurred on long-term rainfall cycles of 4-7 years in south Florida (Thomas, 1974; Beissinger, 1986; Duever et al., 1994),

as well as associated cycles in the timing and extent of wildfires (Beckage and Platt, 2003; Lockwood et al., 2003). Over the past century, the transformation of the Everglades landscape through compartmentalization and canals has partly decoupled the occurrence of droughts and floods from rainfall variability, sometimes shortening or lengthening the intervals between drought and flood events or changing their duration. Restoration of natural hydrologic variation is needed to maintain ecological communities in the Everglades. For example, the reduction of droughts that cause dry-down events can cause a loss of tree islands (Willard et al., 2006), while too-frequent droughts can cause snail kite populations to decline (Beissinger, 1995; Martin et al., 2008) or reduce fish populations so that they can no longer adequately support large predators such as alligators (Mazotti et al., 2009).

Finally, the magnitude and directions of flow have significantly changed as a result of engineering works as shown in Figure 4-3. Among the most important engineering changes was the creation of the WCAs, which interrupted and re-directed the sheet flow that formed and maintained the distinctive features and ecological functions of the Everglades.

The effects of the water management structures on water depths are illustrated in Figure 4-4, in which water depths during the midst of the rainy season are compared to those near the end of the dry season. Figure 4-4 captures a wet year (2006) and shows the extensive ponding that occurs in WCA-3A behind the L-67 levees, which prevent flow from moving southeast into WCA-3B, and above the Tamiami Trail (and its associated levee), which limits the flow of water into Everglades National Park. Similar effects can be seen in the southern ends of WCA-1, WCA-2A, and WCA-2B. Figure 4-4b shows the extent of extreme dry conditions that now occur during drought years, particularly in northwestern portions of the WCAs and Shark River Slough in Everglades National Park, and the persistent ponding in the extreme southern portions of the WCAs and behind the L-67 levees in WCA-3A.

PARTIAL HYDROLOGIC RESTORATION AND SPATIAL TRADEOFFS

Reduced spatial extent, extensive peat loss, and large urban and agricultural demands for water and flood control make it infeasible to fully restore the hydrology of the remnant Everglades ecosystem. Thus constrained, CERP and related projects have aimed at partial restoration toward pre-drainage depths, hydroperiods, and flow regimes. Some of the major features of hydrologic restoration under the CERP are summarized in Figure 4-5. By comparing Figure 4-5 to Figure 4-2, one can see that a fully implemented CERP is expected to lead to large reductions in flood discharges to the northern estuaries, moderate reductions in flood discharges to the WCAs, and significant increases in freshwater inputs to

Current Condition - DRAFT
1965-2000

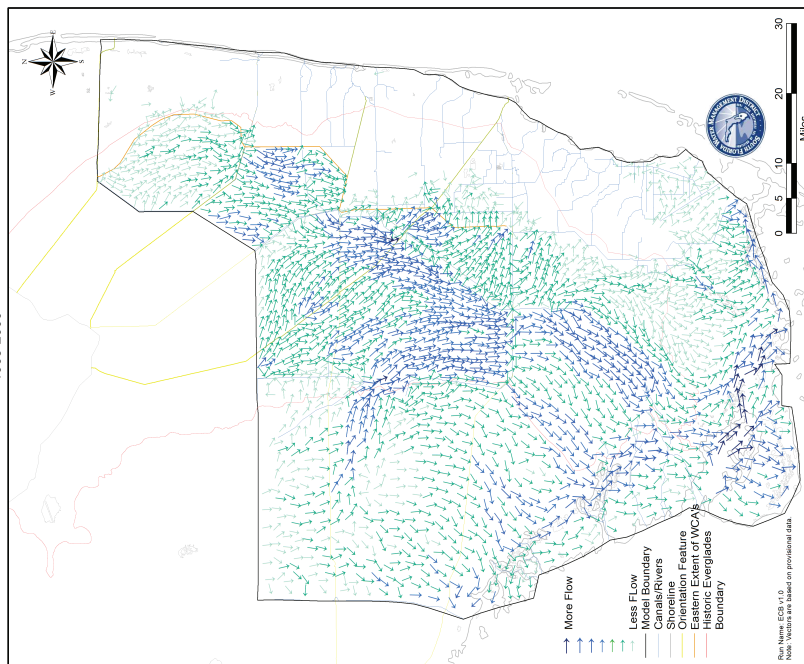

Pre-drainage Condition - DRAFT
1965-2005

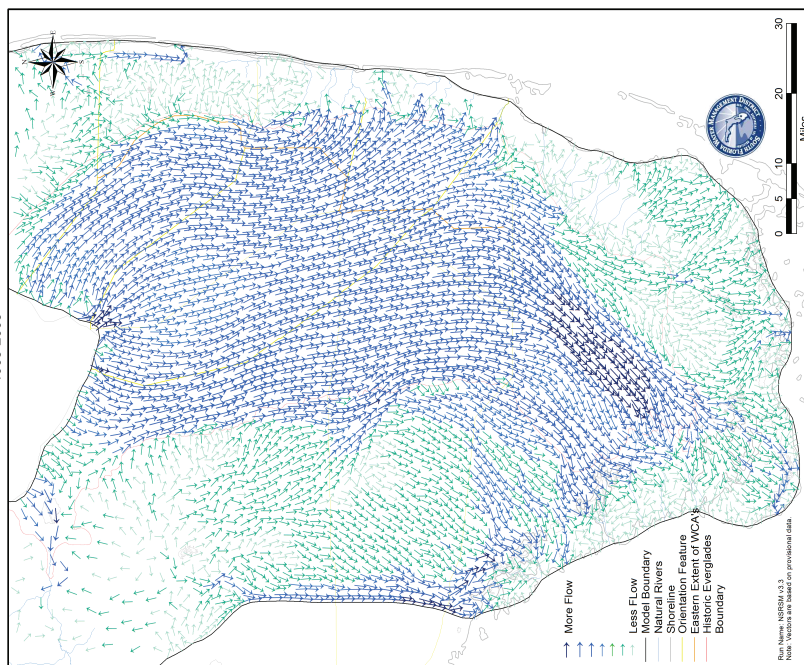

FIGURE 4-3 Simulated mean annual overland flow based on climate data for the period 1965-2000, comparing the system under pre-drainage conditions as modeled by the NRSRM v. 3.3 (left; Said and Brown, 2010) and the present managed system using the Glades-Lower East Coast Service Area (LECSA) model (right; Senarath et al., 2008, 2010; see also Lal et al., 2005; SFWMD, 2006b). The color of the arrows is scaled to reflect the magnitude of flow.

SOURCE: L. Gerry, SFWMD, personal communication, 2010.

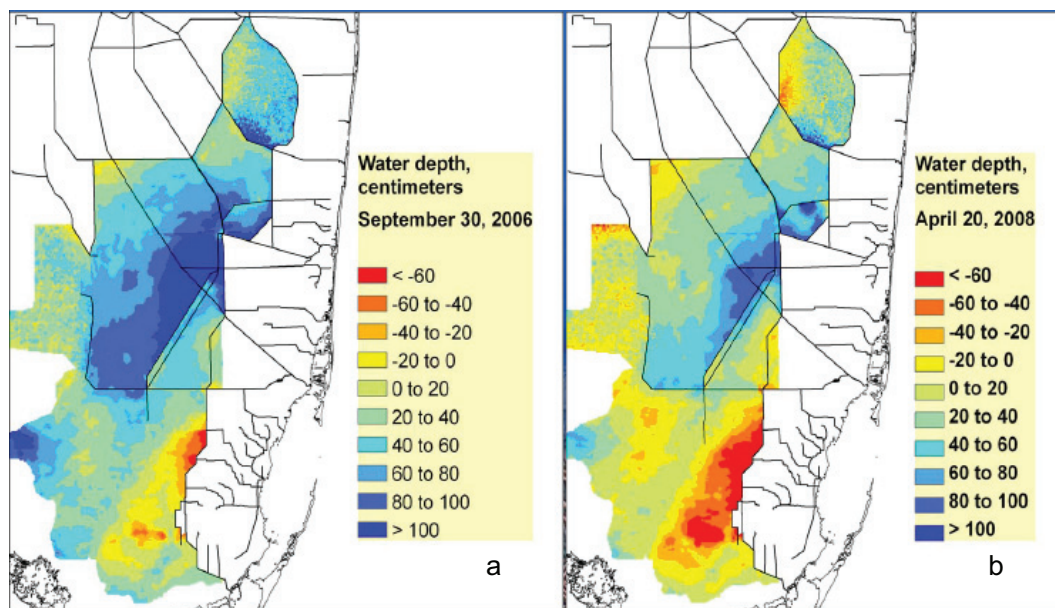

FIGURE 4-4 Example of hydrologic extremes now characteristic of WCA-3 and Shark River Slough: (a) wet conditions observed on September 30, 2006 and (b) extreme dry conditions observed on April 20, 2008.

SOURCE: Johnson (2009) generated using the USGS Everglades Depth Estimation Network (EDEN).

Everglades National Park (see Table 4-1). These and other changes depend on new surface storage, aquifer storage and recovery, wastewater reuse, and other CERP elements described in Chapter 2.

One of the consequences of reduced spatial extent and reduced storage in the modern system is that it may be impossible to get the water “right” or even “better” everywhere at all times. CERP planners have always recognized that restoration benefits would be unequally distributed across the Everglades landscape and that hydrologic conditions might even worsen in some areas in order to achieve desired outcomes in others (USACE and SFWMD, 1999). It is important to understand these tradeoffs and interdependencies when evaluating the design and staging of CERP projects, especially given the kinds of lengthy delays and design changes that have characterized restoration efforts to date. The extent to which one area is impacted to achieve benefits elsewhere depends on the amount of new storage and changing constraints on water distribution such as flood control, seepage management, and water quality.

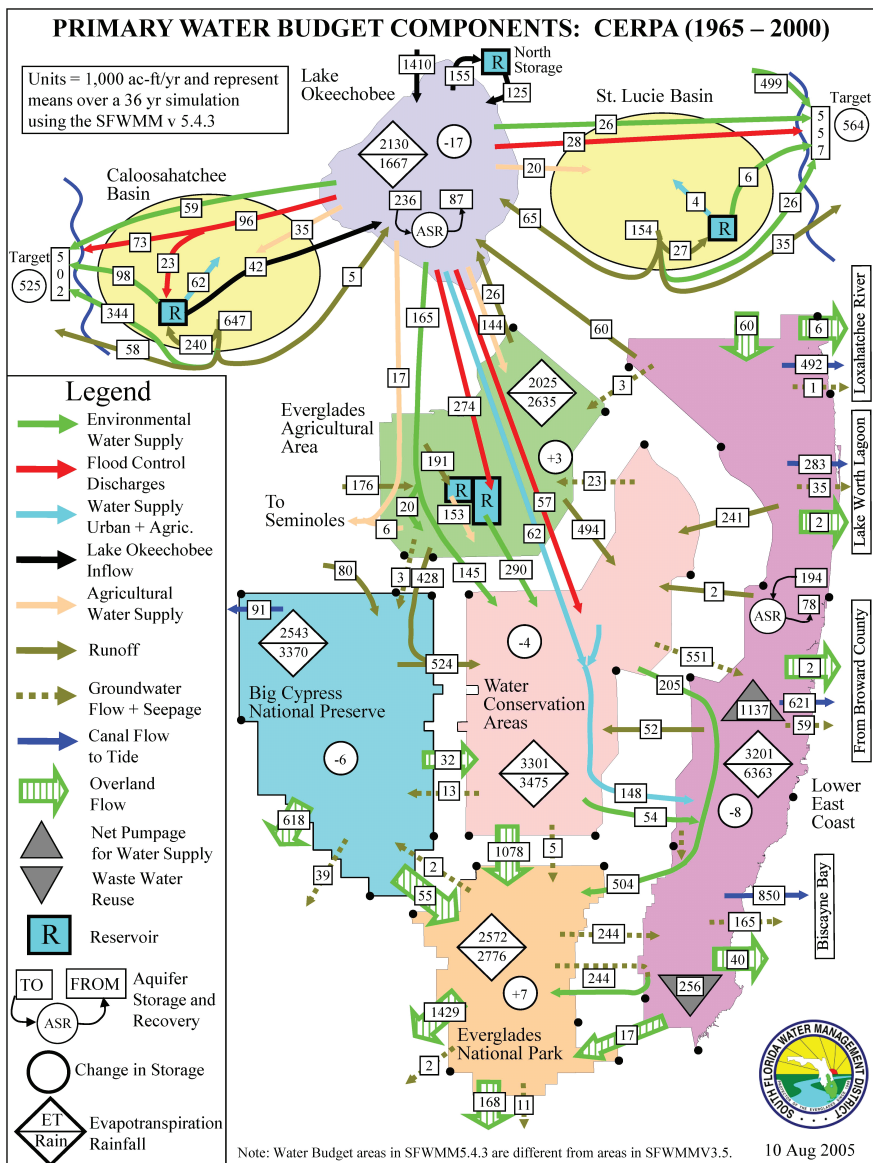

FIGURE 4-5 Estimated annual water budget for the Kissimmee-Okeechobee-Everglades drainage basin under full CERP implementation, calculated using a 36-year simulation using the SFWMM v. 5.4.3. Model run CERP A shown simulates the CERP preferred alternative (D13R). The numbers in rectangles represent mean annual flow volumes in 1,000 acre-feet/year. Change in storage, shown in circles, represents the net inflows minus outflows over the period of record.

SOURCE: J. Obeysekera, SFWMD, personal communication, 2009.

Expected Subregional Differences in CERP Ecological Performance

In this section the committee summarizes how restoration benefits—assessed using hydrologic performance measures—are expected to vary across the Everglades system from Lake Okeechobee southward under full CERP implementation and in the near term with the completion of the initial (Band 1¹) projects. It draws heavily from systemwide hydrologic analyses conducted by RECOVER scientists for the *Initial CERP Update* (RECOVER, 2005c) and *Technical Report on Systemwide Performance of CERP 2015 Band 1 Projects* (RECOVER, 2010c).

CERP scientists have produced an extensive set of performance measures to set restoration targets and to evaluate alternative plans and implementation progress (RECOVER, 2007b). Specific measures and targets have been identified for more than 40 indicator regions corresponding to small clusters of 2-mile by 2-mile grid cells in the SFWMM and NSM. The performance measures capture aspects of the hydrologic regime such as frequency and magnitude of high and low water stages or frequency and duration of inundation. The restoration target for a performance measure in any particular indicator region is typically based on the value obtained using the NSM, but in some cases additional research findings are used to develop relationships between hydrologic observations and ecological factors.

To examine some of the inherent challenges of getting the water right in all places at all times, the committee assembled values for selected performance measures and indicator regions under pre-drainage, current, and 2050 conditions, with and without the CERP (see Table 4-2; RECOVER, 2005c). The table also summarizes model-estimated discharges between selected regions. Performance measures are arranged in rows from north to south starting with Lake Okeechobee and the northern estuaries and ending with Florida Bay. The table also includes modeled ecological performance in 2015 assuming construction of the 1-mile bridge on the Tamiami Trail, new L-29 Canal stage constraints (8.5 feet above sea level), and completion of the following CERP Band-1 projects (see Chapter 3 for the current status of these projects) including:

- Indian River Lagoon C-44 Reservoir
- Broward County Water Preserve Areas (C9 and C11 impoundments)
- WCA-3A and 3B seepage management
- Acme Basin B Discharge
- Site 1 impoundment

¹According to the Master Implementation Sequencing Plan (USACE and SFWMD, 2005a), Band 1 projects represent those that would be completed between 2005 and 2010. However, given the delays in project implementation, the RECOVER (2010b) analysis assumed that these projects could be completed by 2015.

- C-111 Spreader Canal Phase 1 (Frog Pond/Leaky Reservoir)
- North Palm Beach County
- C-51 and L-8 Basin Reservoir Phase 1
- Everglades Agricultural Area (EAA) Storage Reservoir Phase 1
- Lake Okeechobee Watershed Plan
- Rain-driven operations in Rotenberger Wildlife Management Area
- C-43 Basin Storage Reservoir Phase I

TABLE 4-2 Selected Features of the Everglades Water Budget and Regional Performance Indicators

Variable	Water budget (KAF)	Restoration Target	Existing	Future w/o Project	Band 1 Projects SFWMM 5.4.6		Future w/ CERP
		NSM v. 4.6.2 (NSRSM)	SFWMM 5.4.3	SFWMM 5.4.3	2015BS	2015CP	SFWMM 5.4.3 CERPA
1	Lake Okeechobee flood discharges to Caloosahatchee estuary (KAF)	358	376	289			73
2	L. Okeechobee flood discharge to St Lucie estuary (KAF)	0	130	96			28
3	Inflow to WCAs (GW and SW; KAF)	1473	1915	1838			1899
4	Inflow to ENP from WCA 3A & 3B (GW and SW; KAF)	1326	875	1137			1083
5	Total inflow to ENP (GW and SW; KAF)	1760	1174	1499			1903
6	ENP discharge to coastal zone (GW and SW; KAF)	1876	1137	1237			1610
Selected Performance measures							
7	Lake Okeechobee high stage score (0-100, 100 best)	100	98	97	85	82	98
8	Lake Okeechobee low stage score (0-100, 100 best)	100	98	98	98	96	98
9	# mos. Caloosahatchee flow < 300 cfs (420 max)	0	153	145	195	76	18
10	# mos out of 420 when Caloosahatchee flow >2800 cfs	0	82	81	79	50	18
11	# mos out of 420 when Caloosahatchee flow > 4500 cfs	<7	37	36			7
12	# Flood discharge events to St. Lucie	0	57	48			10
13	# mos out of 420 when St Lucie flow < 350 cfs	207	130	131	124	97	28
14	# mos out of 420 when St Lucie flow >3000 cfs	12	30	26	31	23	12
15	# high events in Loxahatchee NWR (IR 101)	6-34	29	15			19
16	WCA-2A (IR 110) inundation (% of model record)	84	87	92	87	89	91
17	WCA-2A (IR 111) extreme high water (% of model record)	0	1	1	1	1	3
18	WCA-2B (IR 113) inundation (% of model record)	91	91	91	86	87	83
19	WCA-2B (IR 113) extreme low water (% of model record)	0	5	4	5	5	7
20	NE WCA 3A (IR 115) extreme high water (% of model record)	0	2	3	3	4	3
21	NE WCA 3A (IR 115) Snail kite foraging (average duration inundation events)	122	88	88			59
22	Central WCA-3A (IR 121) inundation (%)	92	94	92	94	94	97
23	So. WCA-3 (IR 124) inundation (%)	93	98	92	97	93	94
24	Extreme high water, so. WCA-3A (IR 124) (%)	0	24	5	14	9	1
25	W. WCA-3B (IR 126) inundation (%)	96	94	91	93	92	97
26	Extreme high water events w. WCA-3B (IR 126) (%)	5	1	29	14	15	9
27	NE Shark River slough (IR 129) # drydown events	2	18	15			3
28	NE Shark River slough (IR 129) inundation (POR)	99	86	88	86	88	98
29	Central Shark River slough (IR 131) # drydown events	7	19	15			9
30	Central Shark River slough (IR 131) inundation (%)	93	83	89	85	89	94
31	Joe Bay Basin, Florida Bay, 50th% salinity (ppt)	13	14	13.2	14.3	13.4	13.3
32	Garfield Bight, Florida Bay, 50th% salinity (ppt)	28.5	32.7	32.4	33	32.1	30.8

NOTE: The data in this table are based on the NSM v. 4.6.2 of pre-drainage hydrology and the SFWMM v. 5.4.3 for existing conditions, 2015 without Band 1 CERP projects, 2015 with Band 1 CERP projects, 2050 without CERP but with Rain Driven Operations, and 2050 with CERP. The model results are based on climate and rainfall data for the period 1965-2000. The performance measure scores are derived from the *Interim CERP Update* (RECOVER, 2005c) and *Technical Report on Systemwide Performance of CERP 2015 Band 1 Projects* (RECOVER, 2010c). Green cell shading indicates conditions at or near restoration targets (left-most column), yellow indicates conditions approaching the targets but still potentially damaging, and red indicates conditions departing from targets and ecologically undesirable according to RECOVER scientists. Cell colors were chosen by the committee based on interpretations of the performance by RECOVER scientists (RECOVER, 2005c, 2010c).

Northern Estuaries and Lake Okeechobee

Some of the disparities in expected CERP restoration outcomes for different subregions are illustrated in Table 4-2. Under the CERP, new storage would greatly reduce the frequency of unwanted very low or high discharges to the northern estuaries (see #1 and 9-14 in Table 4-2). Many of these benefits could be realized in the near term with completion of Band-1 storage projects such as the C-43, C-44, and EAA reservoirs (Table 4-2). On the other hand, little change is anticipated for Lake Okeechobee, with a small reduction in the frequency of extreme high or low water stages (#7-8, Table 4-2) (RECOVER, 2005c). In the Band 1 scenario, which was based on a different lake regulation schedule than is currently in use, unwanted high lake stages could increase in order to achieve other systemwide benefits such as reduced flood discharges to the estuaries and increased dry-season releases to Everglades National Park while avoiding additional cutbacks in water supply to the Lake Okeechobee service area (RECOVER, 2010c). These high lake stages are less likely under the current regulation schedule for the lake (J. Vearil, USACE, personal communication, 2010).

Arthur R. Marshall Loxahatchee National Wildlife Refuge (LNWR) and WCA-2

Under the CERP, total inflow from the north into the WCAs should increase slightly (#3, Table 4-2), seasonal timing should come closer to pre-drainage conditions, and spatial distribution of inflows should improve compared to current canal deliveries. Hydrologic conditions improve slightly in the LNWR, but the frequency of damaging extreme high and low water events would increase in WCA-2A (#15-17, Table 4-2). At the same time, high water events should be less frequent and low water events more frequent in WCA-2B (#18-19, Table 4-2). In the near term, Band 1 projects are expected to slightly increase hydroperiods in WCA-2A, where they are already deemed excessive (#16, Table 4-2). Band 1 projects would reduce the risk of high water conditions in WCA-2B but create generally drier conditions that are not consistent with ridge and slough restoration (#19, Table 4-2; RECOVER, 2010c).

WCA-3

Modeled restoration outcomes in WCA-3A vary widely among subregions. In northeastern WCA-3A, the CERP should slightly reduce the frequency of high water extremes but increase the frequency of low water extremes relative to the future without the CERP (#20-21, Table 4-2). Band 1 projects have complex effects related to management of stormwater treatment area discharges (STA 3/4), but they will likely increase drought impacts in northern WCA-3A as rain-driven

operations increase flows to Everglades National Park and southern coastal systems (RECOVER, 2010c). In central WCA-3A, the CERP increases the duration of flooding compared to the future without the CERP, creating hydropatterns that would likely adversely affect the best remaining ridge and slough landscape (#22, Table 4-2; RECOVER, 2005c). On the other hand, the CERP significantly reduces the duration of flooding and extreme high water conditions in southern WCA-3A (#23-24, Table 4-2), improving conditions for tree islands there. Band 1 projects alone should appreciably mitigate flooding problems in southernmost WCA-3A.

Restoration outcomes in WCA-3B are especially uncertain. Without the CERP, the area is likely to continue moving farther from pre-drainage ecological conditions. Re-inundating the area could create excessive high water conditions (#25-26, Table 4-2). Peat elevations have subsided by 1–3 feet since compartmentalization, and re-flooding of WCA-3B would not only require extensive seepage management but also would likely lead to the loss of peat-based tree islands that have subsided 2–3 feet since the area was compartmentalized (RECOVER, 2010c). Band 1 projects, which begin to reconnect WCA-3A, WCA-3B, and Everglades National Park, introduce increased risk of extreme high water events in WCA-3B, leading RECOVER scientists to recommend careful adaptive management of the transition to a wetter hydrologic regime in that area (RECOVER, 2010c).

Everglades National Park

The CERP provides a roughly 75 percent increase in surface flow into Everglades National Park, with much of this additional water to arrive via an eastern flow-way supplied by new belowground reservoirs called the Lake Belt (Figure 4-5; Table 4-1). Increased freshwater discharges produce large improvements in key performance indicators south of the Tamiami Trail. For example, the inundation periods for northeast and south-central Shark River Slough and the frequency of dry-down events are expected to approach NSM-based targets (#27-30, Table 4-2). Only modest benefits are obtained from Band 1 projects because more substantial ecological benefits depend on water provided by future CERP projects (RECOVER, 2010c).

Southern Estuaries

Freshwater inflows to Florida Bay would increase under the CERP and would lower the currently high salinities in coastal embayments. Based on historical empirical relationships CERP flows are not sufficient to achieve restoration targets in western embayments (e.g., Garfield Bight), but they bring salinity

levels down appreciably in eastern Florida Bay (#31, 32 in Table 4-2). Modeled restoration benefits for Biscayne Bay (not shown here) are slight: In fact, future-without-project hydrologic outcomes are closer to targets than CERP outcomes for northern and central Biscayne Bay (RECOVER, 2005c).

Summary

To summarize, model results for full CERP implementation (based on the 1965-2000 period of record) indicate that the benefits of hydrologic restoration of the South Florida ecosystem will accrue mostly to the northern estuaries, southern WCA-3A, Everglades National Park, and eastern Florida Bay, areas where hydroecological conditions are currently far from desired conditions (Table 4-2). However, the CERP could exacerbate excessive wet or dry conditions in some regions of the WCAs, including areas such as central WCA-3A, which is considered a relatively intact remnant of the ridge and slough landscape. New modeling using the NSRSM shows a wetter pre-drainage system compared to the NSM, perhaps reducing concern about areas made wetter by restoration but moving relatively dry areas even further from desired conditions. Ecological outcomes in WCA-3B are especially uncertain because of peat subsidence and the risk of drowning much-lowered tree islands, which argues for deliberate, incremental, adaptive restoration of this area in particular.

Balancing Competing Objectives and Tradeoffs in Everglades Restoration

Despite the many sources of uncertainty in estimates of the CERP's systemwide hydrologic budgets,² systemwide modeling contributes importantly to understanding dynamic relationships between subareas, how those relationships have changed over time, and how they could be affected by different restoration project designs. Systemwide hydrologic modeling helps to identify the tradeoffs that have been made and, by necessity, continue to be made in Everglades restoration. It is important that the tradeoffs resulting from CERP restoration be clearly recognized and analyzed as rigorously as possible from a whole-system perspective during project planning. Because stakeholder concerns often focus on specific subregions, it is also important that the analyses of tradeoffs are transparent and that the results and uncertainties are communicated clearly to the public, even at the risk of fueling political conflicts between different interest groups.

²Sources of model uncertainty include coarse model resolution, inaccurate topography, uncertain parameters for estimating overland flow, infiltration and evapotranspiration, poorly understood surface-groundwater exchanges, and speculative water supply demand forecasts.

Disparities occur among models, for example, the NSM versus the NSRSM, or among different versions of the SFWMM and the RSM under development. These disparities highlight the clear need to continue refining and updating regional hydrologic models as the CERP moves forward so that the tradeoffs can be more confidently evaluated and addressed through project design and system operation.

CERP planning has made appropriate use of performance measures that link hydrologic conditions to ecological restoration goals for specific areas; however, there is still no formal analytical approach to measuring the relative systemwide benefits of alternative restoration plans or components that integrates across the kinds of tradeoffs described in this section. There is no explicit basis for gauging the degree to which a plan alternative or a set of projects satisfies multiple ecological restoration goals as well as flood control and water supply objectives. The need for such a planning framework was identified several years ago by a previous National Research Council (NRC) committee (NRC, 2005) and has also been recognized by RECOVER scientists (RECOVER, 2010c). A review of the many approaches for multi-objective water management planning is beyond the scope of this chapter. Loucks (2006) offers one pragmatic approach to evaluating systemwide performance in the Everglades that takes advantage of existing performance measures.

Short-Term Benefits and Risks of Partial Restoration

The RECOVER (2010c) analysis of systemwide performance of Band 1 projects offers a likely scenario of Everglades restoration outcomes over the next decade (assuming that the EAA Reservoir is brought online during that time). The distribution of restoration benefits is similar to that under full CERP implementation: the greatest measurable benefits are to the northern estuaries, southern WCA-3A, and Everglades National Park, and increased risks are placed on Lake Okeechobee and portions of the WCAs, notably southern WCA-2, northern WCA-3A, and WCA-3B.

Improved conveyance and better distribution of water in southern WCA-3A and Everglades National Park will be at the expense of shorter hydroperiods and increased risk of severe dry-down events and wildfires in northern WCA-2A and northern WCA-3A until storage is increased and water quality concerns are mitigated so that more water can be moved south from Lake Okeechobee and the EAA. It is important to recognize that it will be many years before the storage (and, by necessity, the associated water quality treatment and/or source control; see Chapter 5) needed to address these issues in WCA-2A and northern WCA-3A is functional. Band 1 projects contribute only 9 percent of the 5.2 million acre-feet/year of storage originally envisioned for the CERP and largely affect the

northern estuaries, not the Everglades Protection Area (RECOVER, 2010c). Furthermore, the currently stalled EAA Reservoir (170,000 acre-feet/year) is the only reservoir among the Band 1 projects that could impact the remnant Everglades ecosystem, and the benefits of this project to the area south of Lake Okeechobee were not clear as of the latest draft project implementation report (USACE and SFWMD, 2006; NRC, 2007). Even with the EAA Reservoir, downsized Band 1 storage projects will now provide only 73 percent of the capacity expected from those projects in the original CERP plan (RECOVER, 2010c). Because the planning and decision making for the River of Grass initiative has been suspended to address pressing water quality issues and because state funding to support major additional land acquisitions is uncertain, it remains unclear what new storage and treatment could be available through that effort (see also Chapter 3). Thus for at least the next decade, it appears that managing ecological risks across the system comes down to adaptive management of existing water.

Any consideration of ecological risks from water management should also consider the timescale over which adverse ecological outcomes might be reversible, if they are at all. For instance, peat accumulates at a rate of only 2–3 mm/year (<1 foot per century) in unenriched Everglades wetlands (Craft and Richardson, 1993), so deep peat loss is effectively irreversible. Changes in hydrology or fire regime can cause rapid changes in plant communities but some communities such as tree islands may require relatively long time periods for recovery (White, 1994). Because some areas might, by necessity, need to be exposed to adverse hydrologic conditions during the transition to the full CERP implementation, the ability to restore these areas once additional projects come online would need to be considered in any assessment of tradeoffs.

CASE STUDY: RESTORING WATER FLOWS IN WCA-3

The challenges of balancing competing objectives and the tradeoffs inherent in restoration are well exemplified in WCA-3. WCA-3 is central to the Everglades restoration, because it contains extensive and relatively intact Everglades landscapes, such as tree islands and ridge and slough, and it provides critical habitat for endangered species such as the snail kite and wood stork as well as nonthreatened wading birds. The area is also valued for its recreational fishing and hunting. The Miccosukee Tribe has a perpetual lease to more than 189,000 acres of the western portion of WCA-3A and relies upon Everglades lands to support its culture, religion, and economic survival. Moreover, the management of water through WCA-3 plays a key role in restoring the condition of Everglades National Park immediately downstream. Inherent constraints (e.g., peat subsidence, availability of high quality water [see also Chapter 5], barriers to flow such as the Tamiami Trail) create challenges for simultaneously improving all aspects

through restoration. In this section, the committee discusses these challenges in more detail through an examination of issues related to the management of water in WCA-3 and identifies specific science and management needs to guide restoration decision making as the CERP moves forward.

Brief History of the Challenge of Managing Water for Multiple Uses in WCA-3

The WCAs were authorized based on three sometimes conflicting water management goals (USACE, 1996; Light, 2006). First, the WCAs were intended to address flood control issues by capturing excess agricultural runoff and providing barriers between the Everglades and developed areas to the east. Second, they were to provide urban and agricultural water supply needs through above-ground storage and groundwater recharge. Finally, the WCAs were to provide benefits for the environment, both within the conservation areas themselves and by discharging excess water to Everglades National Park. WCA-3 is by far the largest of the conservation areas (915 square miles or 68 percent of the total area) and includes the main historical pathway for surface-water flow from Lake Okeechobee through South Florida. In 1962, WCA-3 was subdivided by the L-67 levees into WCA-3A (491,049 acres) and WCA-3B (94,511 acres) to reduce seepage (see Figure 1-3). WCA-3A is the largest area of contemporary sheet flow. Additional information on WCA-3 and its management is provided in Box 4-2.

Challenges in managing water for multiple uses in WCA-3 became apparent soon after it was created (Blake, 1980). Between 1966 and 1970, large numbers of white-tailed deer (*Odocoileus virginianus*), which had moved into portions of the WCA-3 that were abnormally dry due to drought and previous water management policies, died when water levels rapidly increased after heavy rains. Similar deer mortality events have recurred periodically thereafter (e.g., 1982-1983, 1994-1995) under similar conditions (see MacDonald-Beyers and Labisky, 2005). In the mid-1960s, drought and fires ravaged Everglades National Park in part because water was being held in WCA-3 for water supply, and this eventually resulted in a Minimum Delivery Schedule volume of 315,000 acre-feet/year to be allocated to the park according to a monthly schedule (Carter, 1975; Blake, 1980).

From the mid-1980s to present, conflicts have centered on the benefits that can be achieved by changing flows to Everglades National Park for restoration of ecosystems and endangered species versus the negative impacts upstream in WCA-3 to ecosystem processes, endangered species, recreational interests, and tribal concerns. Conflicts in the early to mid-1980s centered around the benefits of increasing flows to Shark River Slough and Florida Bay to restore ecosystem processes and recover wading bird populations (including the endangered wood stork), and the resulting negative effects of lower water levels in WCA-3A on the

endangered snail kites and higher water levels in WCA-3B on white-tailed deer. The Experimental Water Deliveries Program (see summary in Chapter 2 of NRC, 2007), the Modified Water Deliveries to Everglades National Park (Mod Waters) project, and the CERP emerged from this conflict. In the late 1990s, concerns that too much water from WCA-3A was flowing into the western portion of Everglades National Park during the nesting season of the endangered Cape Sable seaside sparrow (January-April) and flooding nests resulted in the Interim Structural and Operational Plan (ISOP) in 2000, followed by the 2002 Interim Operation Plan (IOP) that is currently in use (see Box 4-2 and the next section).

Recent Water Management in WCA-3

Inflow and outflow of water in WCA-3 are regulated under the IOP by the water level targets and conditions in both WCA-3 and Everglades National Park (see also Box 4-2). The regulation schedule (Appendix D) is designed to mimic the historical changes in water levels thought to accompany seasonal changes in precipitation, as discussed previously in this chapter. Levels rise during the rainy summer months to peaks between September and November, and levels fall during the drier months beginning in January or February, reaching a low from May through July. A major change in management under the current operations (IOP) has been to close or greatly reduce the flow of water out of the western S-12 gates at the southern end of WCA-3A into Everglades National Park for most of the winter and spring to accommodate the nesting season of the Cape Sable seaside sparrow. Gate S-12A is closed on November 1, S-12B is closed on January 1, and S-12C is closed on February 1. These S-12 closures were accompanied by a change in the IOP regulatory zones (addition of Zone E1, see regulation schedule in Appendix D) that allows for maximum WCA-3A outflows at lower stages, and through increased WCA-3A outflows to the South Dade Conveyance System. In spite of these changes designed to move more water out of WCA-3A, the reduced flow out of the S-12 gates has been accompanied by higher water levels, longer hydroperiods, and greater fluctuations in water levels in WCA-3A.

These effects of water management can be seen in the hydrographs of long-term water stages in WCA-3A (Figure 4-7). Since completion of the C&SF project, WCA-3 has experienced four water management regimes: early operations (~1950–1969), minimum water delivery (1969–1984), Experimental Water Deliveries (1984–1999), and ISOP/IOP (1999–present). Water levels in WCA-3A began increasing in the mid-1990s with rainier conditions and have remained notably higher during the past decade under IOP, despite several regional droughts that have occurred. During IOP, the average daily water level has been significantly higher in all three regions of WCA-3 than in any other water management regime (Figure 4-8). In addition, the annual maximum and mini-

BOX 4-2 Water Management in WCA-3

Management of water levels within Water Conservation Area (WCA)-3A and WCA-3B is the responsibility of the South Florida Water Management District (SFWMD) in accordance with regulation schedules set by the U.S. Army Corps of Engineers (USACE). Wildlife management is delegated to the Florida Fish and Wildlife Conservation Commission under lease from the SFWMD. The Jacksonville District of the USACE operates and maintains the main outlets of the WCAs.

Currently more than half of the 1.8 million acre-feet (MAF) annually discharged into WCA-3A comes from WCA-2 via the S-11 structures (Figure 4-6). Water is discharged into northern WCA-3A mainly from stormwater treatment areas (STAs)-3 and -4 through S-8 and S-150 control structures and from the east via S-9 and S-9A. The timing and rate of inflows to WCA-3A are governed by flood control releases when stages in Lake Okeechobee or WCA-2 exceed seasonally varying thresholds. Inflows are also limited by the capacities of STAs receiving water from Lake Okeechobee.

WCA-3 is bordered to the south by the Tamiami Trail. The inability of the Tamiami Trail to pass large volumes of water without compromising the integrity of the road base led to a long history of water management problems both north and south of the trail (see also NRC, 2008). About half of the outflow from WCA-3A currently discharges into Everglades National Park (ENP) via the S-12 structures through culverts under western portions of Tamiami Trail. Much of the remaining outflow is conveyed south via the L-67 extension and L-31 canals or west into Big Cypress National Preserve through the S-343 structures. Scheduling of the amount and timing of water deliveries to ENP has been especially contentious as water managers have sought to reduce ecological impacts while meeting demands for flood control and water supply.

The current regulation schedule for WCA-3A along with actual water levels at selected stations in 2008 and 2009 are shown in Appendix D. Discharges from WCA-3A to ENP are governed in part by the Interim Operation Plan (IOP) that requires seasonal closings of the release gates on structures S-12A (November 1-July 15), S-12B (January 1-July 15) and S-12C (February 1-July 15) to prevent excessive flooding of nesting habitats for Cape Sable seaside sparrows. At lower water levels releases are determined by the amount of rainfall in WCA-3A using a simple linear regression model relating flow outflow to rainfall and evaporation. Ultimately, the IOP will be superseded by the Combined Structural and Operational Plan (CSOP), which would govern the operations of WCA-3 with all Mod Waters and C-111 South Dade project features in place.

imum water levels have tended to increase in the central and southern regions of WCA-3A, although the mean was not significantly different from the decade of Experimental Water Deliveries.

Hydrographs from the northern (GA-63), middle (GA-64), and southern (GA-65) regions of WCA-3A also illustrate the influence of water management regimes on stages by region (Figure 4-7). Although the northern end of WCA-3A

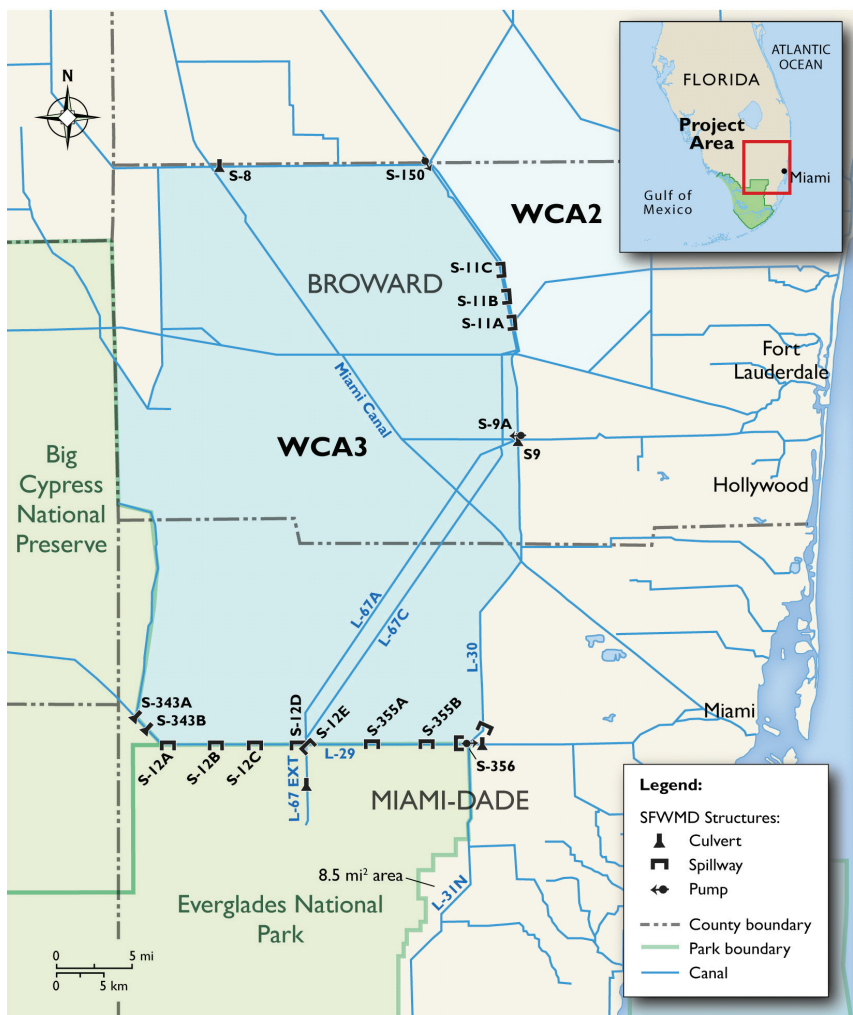

FIGURE 4-6 Water management structures in WCA-3. Gage locations also shown for data presented in Figure 4-7. © International Mapping Associates.

dries out every year, water levels in the southern end have not reached average ground level since the mid-1990s. Over the past 50 years, average daily water levels (Figure 4-8) have increased the most in the southern region (GA-65), followed by the central region (GA-64). Likewise, the southern end of WCA-3A experienced the largest increases in annual minimum and maximum water

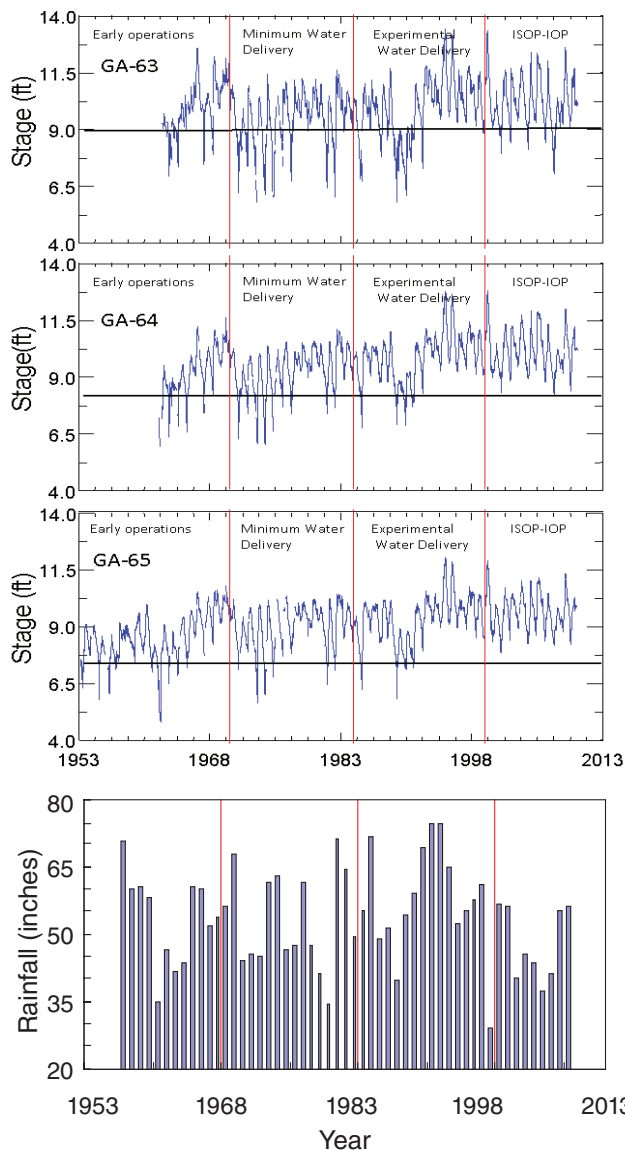

FIGURE 4-7 Water levels at three gauges in WCA-3A: GA-63 at the northern end, GA-64 in the central region, and GA-65 at the southern end. Gage locations shown in Figure 4-6. Major water management regimes are indicated at the top of each hydrograph and average ground elevation by the dark horizontal line. The bottom graph shows annual average rainfall totals across a network of over 50 gages in the NOAA Everglades and southwest coast region, covering the area from Lake Okeechobee southward. Data from the SFWMD and NOAA.

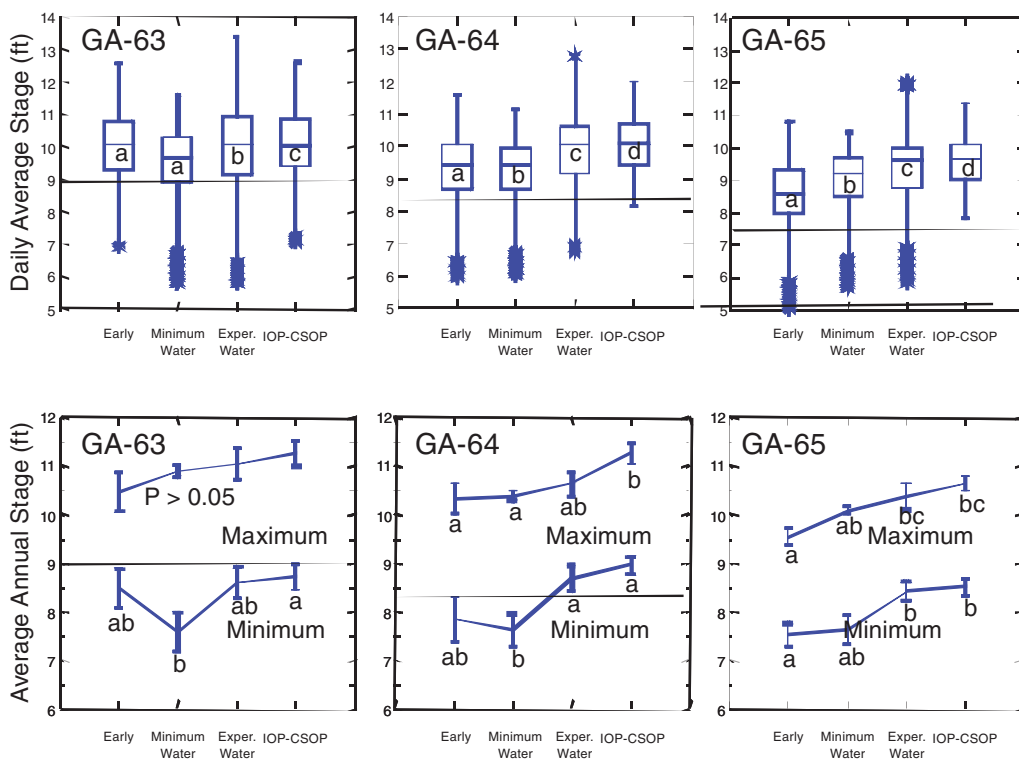

FIGURE 4-8 Daily annual average and average annual minimum and maximum water levels for gauges GA-63 (northern), GA-64 (central), and GA-65 (southern) in WCA-3A (shown in Figure 4-7) for major water management regimes.

NOTE: Average-ground elevation is indicated by the dark horizontal line. In the box plots for daily average stage, the central vertical line indicates the median, the length of the box indicates the range for 50 percent of the observations, the whiskers account for the 95 percent confidence intervals, and * are outlying values. Within each plot, boxes with different letters are significantly different ($P < 0.05$) based on a one-way ANOVA and Tukey's means separation test.

SOURCE: Data from the SFWMD.

levels, while the central region had moderate increases and the northern end experienced the least change.

Recent and Long-Term Ecological Decline in WCA-3A

WCA-3A encompasses the most extensive, relatively intact ridge and slough landscapes remaining in the Everglades ecosystem, including tree islands, and provides critical habitat for endangered species such as the snail kite and wood stork. Profound ecological changes in WCA-3A have accompanied the compartmentalization and water management policies summarized above, especially in northwestern and southeastern subregions (Box 4-2, Figures 4-7 and 4-8). Some ecological consequences occurred rapidly, such as declines in snail kite numbers and nesting success, whereas others have taken place more or less sporadically over multiple decades, such as the declines in tree island size and number, the condition of ridge and slough topography and associated flow paths, and peat loss. As a result, WCA-3A has become a focus of growing public controversy and management concern.

Rapid Decline of the Endangered Snail Kite During the Past Decade

The snail kite is currently the most endangered vertebrate in Florida after the panther (*Puma concolor*). As described in Chapter 2, the population of snail kites has plummeted from more than 3,500 birds to fewer than 650 over the past decade, and water levels in WCA-3A have been an important contributor to the kite's decline in addition to regional droughts (see Figure 4-9; Cattau et al., 2008, 2009). WCA-3A has been the stronghold for kites in Florida since completion of its surrounding levees in the mid-1960s, which probably saved the kite from extinction in Florida. Large numbers of kites have nested in the southern half of WCA-3A since the mid-1970s, and nesting success has typically been higher in this wetland than in others throughout the state (Snyder et al., 1989; Cattau et al., 2008). In recent years, however, conditions in WCA-3A have resulted in poor reproduction, reduced juvenile survival, and largely reduced numbers of kites nesting there (see also Chapter 2; Cattau et al., 2009).

The current regulation schedule in WCA-3A has contributed to the snail kite's precipitous decline in several ways. First, temporarily holding water behind the S-12 structures from November to April to accommodate the breeding season of the Cape Sable seaside sparrow in Everglades National Park has prolonged high water events in WCA-3A in some years, which can reduce the number of kites using this wetland and their nesting and foraging success (Darby et al., 2008; Martin et al., 2008; Zweig and Kitchens, 2008). Second, the high water levels in January to April that encourage kites to nest on the western side of WCA-3A, which is shallower and contains more woody vegetation, have often been coupled with abnormally fast recession rates when the S-12 structures are opened. This results in sudden dry conditions that decrease nesting success

(Figure 4-9b) by making nests more vulnerable to terrestrial predators; the dry conditions also decrease the survival of juveniles after fledging by reducing the availability of the snails that are their primary food source (Beissinger, 1986; Cattau et al., 2008). Third, the current regulation schedule has increased the

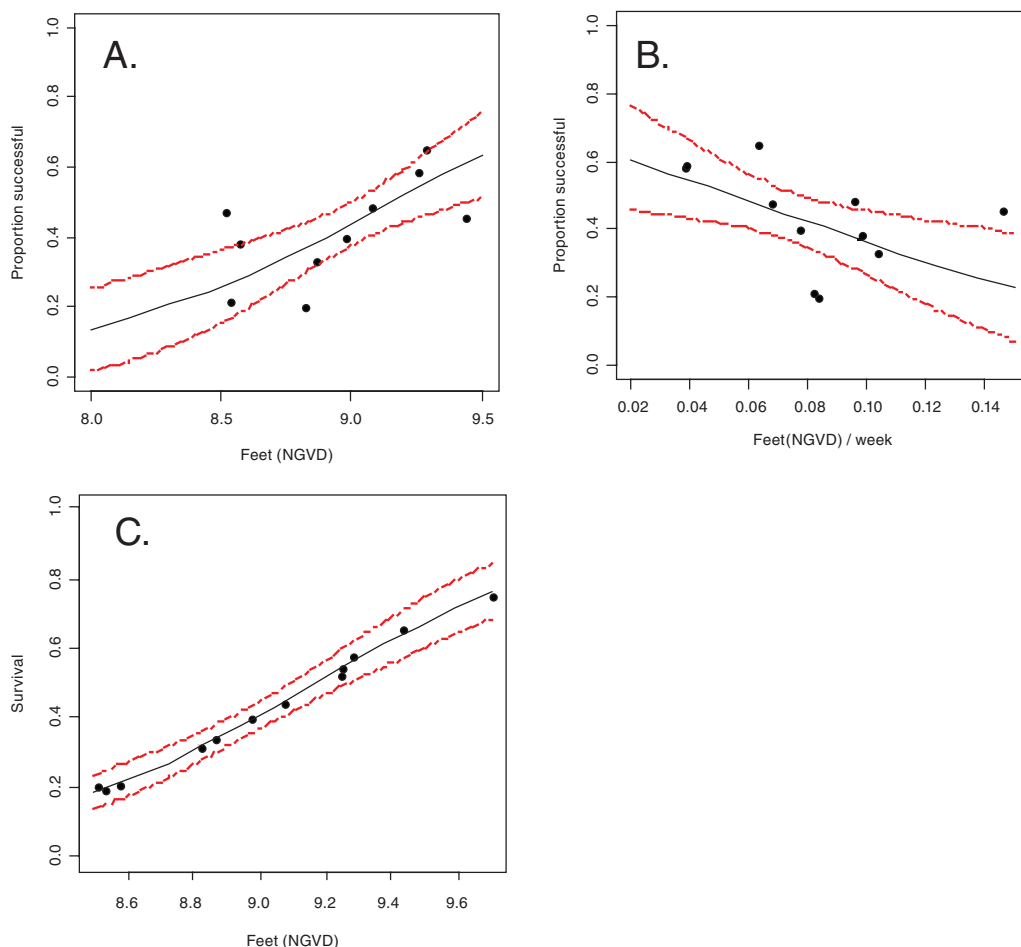

FIGURE 4-9 Relationship between water levels, nesting success, and juvenile survival of snail kites nesting in WCA-3A: (A) annual minimum water levels versus proportion of nests that successfully fledged at least one young (nesting success); (B) rate of water level recession (January 1 to annual minimum) versus nesting success; and (C) annual minimum water level versus survival rate of juveniles. The regression line is in black, the 95 percent confidence intervals are in red, and all values are represented by NGVD (National Geodetic Vertical Datum) values.

SOURCE: Cattau et al. (2008).

likelihood of localized drought in WCA 3A during dry years (Cattau et al., 2008), which has adversely affected kite populations because juvenile survival and nesting success are related to minimum annual water level (Figure 4-9b). Finally, the current water regulation schedule has the potential to shorten the number of months during which kites can breed (Mooij et al., 2002). Kite population growth is strongly positively related to the duration of the breeding season because long breeding seasons allow multiple nesting attempts that offset typically low probability that any one nesting attempt will be successful (Beissinger, 1986, 1995). In conclusion, snail kite reproduction in WCA-3A now suffers from a water regulation schedule that appears to exaggerate the seasonal changes in water levels and does not mimic the seasonal patterns expected in a wetland driven by a natural hydrologic cycle and seasonal flows.

Loss of Tree Islands

Altered hydrology has produced myriad vegetation changes in the South Florida ecosystem. Drought-prone areas of northern WCA-3 have experienced peat loss, increased wildfire frequency, loss of tree islands, shrub invasion into emergent wetlands, loss of aquatic plants, sawgrass expansion into former slough wetlands, altered periphyton communities, and increased establishment of invasive exotic species (NRC, 2008; RECOVER, 2008). Tree islands may be consumed by fire, but trees may also die from excessive drought when water levels are more than 1 foot below ground for more than 30 days (Sklar et al., 2009b). At the other extreme, in areas such as southern WCA-3A where there is extended ponding of deep water, tree islands area has been accompanied in recent years by a lack of seedling establishment caused by stress from prolonged inundation (McKelvin et al., 1998; see Figure 2-13). Growth and survival of even the most water-tolerant species are inhibited or reduced when water depths on islands exceed 1 foot for more than 120 days (Wu et al., 2002).

Tree islands cover less than 5 percent of the Everglades, but they number in the thousands, ranging in area from less than 10 m² to more than 70 hectares (ha; 173 acres) (Sklar and van der Valk, 2002). The systematic loss of tree islands from the central Everglades is of special concern because of their long time to establish, their high species diversity, and the disproportionate role they play in nutrient cycling and in supporting wildlife populations (Sklar and van der Valk, 2002).

Within WCA-3, there was a 67 percent decrease in total tree island area and a 45 percent decrease in the number of islands between 1940 and 1995 (Patterson and Finck, 1999; Sklar et al., 2005). Some tree islands have become “ghost islands” of standing dead trees or have disappeared altogether. The largest

period of tree island loss occurred between 1950 and 1970, with slower rates of loss before and after. The most recent analysis shows that between 1995 and 2004 tree island area declined an additional 520 acres (6 percent), and the number of tree islands declined by 11 percent (Figure 4-10).

Ridge and Slough

Ridge and slough landscapes are characteristic of the Everglades. They are defined by long, regularly spaced ridges of sawgrass that extend across a marsh in a linear fashion and are separated by interconnected wet sloughs and scattered tree islands (SCT, 2003). Major changes in the conditions of ridge and slough patterns can occur surprisingly quickly—within a decade—in response to changes in water depths and flow if the surface retains its underlying microtopography (Armentano et al., 2006; Sklar et al., 2009b). For example, Armentano et al. (2006) showed that within Taylor Slough, vegetation transitions between ridge

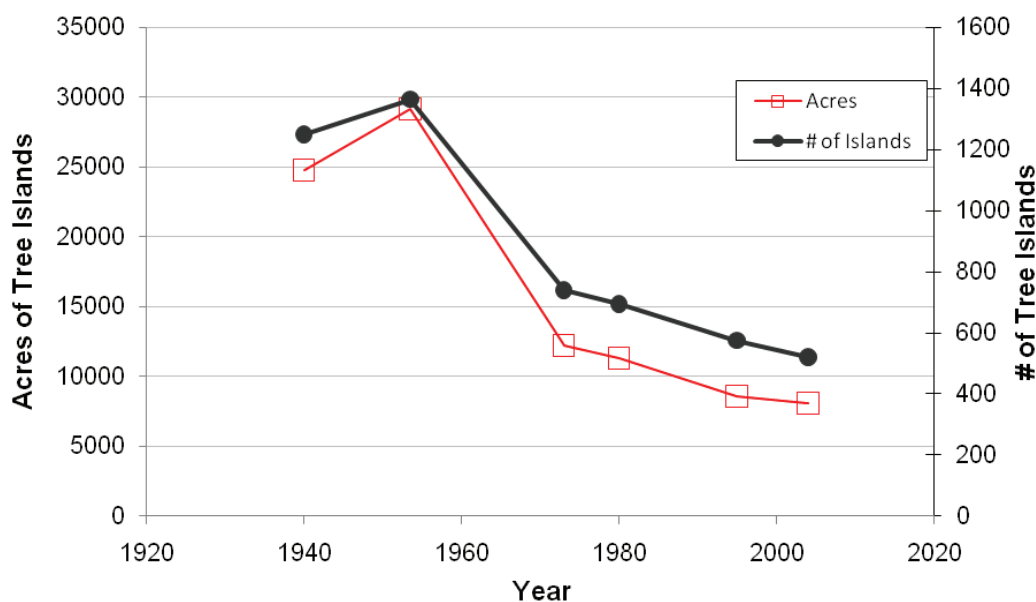

FIGURE 4-10 Tree island trends between 1940 and 2004.

SOURCE: F. Sklar, SFWMD, personal communication, 2010.

and slough communities occurred within a few years of building and operating the S-332 pump. The causes of pattern changes (Figure 2-13) are uncertain, but analyses suggest that local factors rather than regional factors are responsible, particularly water depth, flow, elevation and vegetation patterns, and the transport of sediment (Chapter 6). It can, however, take decades to centuries for flows across peatlands to rebuild the ridge and slough configuration of the topography (Willard et al., 2001).

Long-Term Peat Loss

Between 1950 and 2000 the Everglades Protection Area lost roughly 28 percent of its peat soils by volume due to drying, oxidation, and burning (Figure 4-11). That loss has been especially pronounced in northern WCA-3A, WCA-3B, and northeast Shark River Slough. As a result, soils in northern WCA-3A are now shallower (average depth <2 feet), denser, and have lower organic matter content than any other region of the WCAs (EPA, 2007). Even if the water flows were restored to these areas, rebuilding this lost peat and associated soil biogeochemical and ecosystem properties would take centuries. These losses have important implications for the maintenance of landscape features and characteristic vegetation in these areas. The loss of peat thickness has several important effects on Everglades landscapes, including increased exchange of surface water and groundwater with chemical and hydrologic consequences; and, as mentioned above, the loss of peat represents the loss of the substrate required to build and maintain the ridge and slough landscape. It also results in loss of elevation and therefore increases flooding depths and durations.

Balancing Multiple Restoration Objectives for WCA-3

As is discussed previously in this chapter, managing water upstream of the Tamiami Trail in WCA-3 and downstream in Everglades National Park to promote the restoration of multiple species and multiple ecosystem restoration objectives in both areas has proven to be problematic over the past five decades. Excessive drying or flooding has resulted in peat loss from subsidence and wildfires, loss of tree islands and encroachment by shrubs into emergent wetland habitats, loss of characteristic ridge and slough topography, and declines in snail kites in WCA-3. Similar problems have occurred for these same ecological features and the Cape Sable seaside sparrow (see Chapter 2) in Everglades National Park. Restoration success for both units is inextricably bound because flows in Everglades National Park and WCA-3 are interdependent because of their adjacent geographic locations. In this section, the committee discusses ways to balance the multiple restoration objectives for both WCA-3 and Everglades National

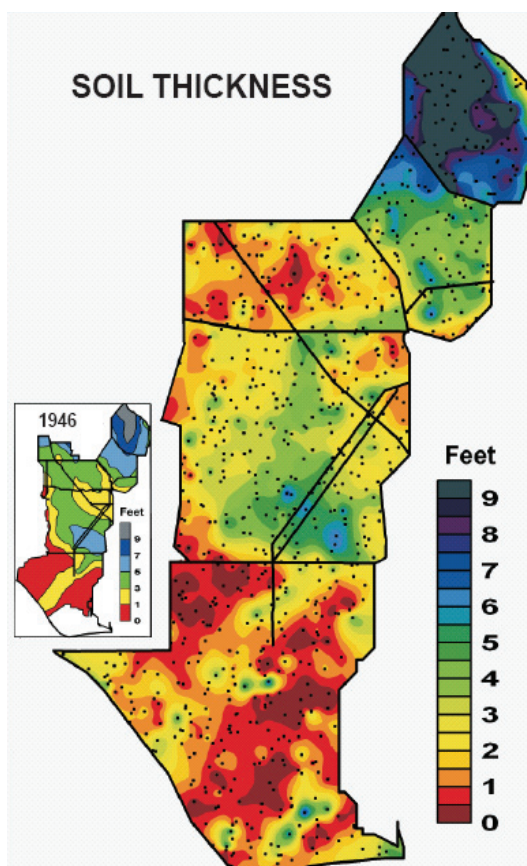

FIGURE 4-11 Soil thickness at 867 locations measured between 1995 and 2005, contrasted against thickness from 1946 as shown in inset map.

SOURCE: Scheidt and Kalla (2007).

Park by examining long-term and near-term implementation issues in relation to CERP and non-CERP projects and by articulating conflicts among the hydrologic needs of species that could be evaluated and tradeoffs that could be analyzed (see also NRC [2005] for discussion of tradeoff analysis). The committee also considers the prospects for making management operations more responsive to real-time ecological conditions.

Several CERP and non-CERP projects aim to improve the hydrologic conditions in WCA-3, although benefits from the largest projects (i.e., Decomp, L-31N Seepage Management) are roughly a decade away. In Box 4-3 near-term

non-CERP and CERP projects affecting WCA-3 and Shark River Slough are summarized. As described in Chapter 3 and above, these near-term projects will shift more water flow to the east, allow increased conveyance from WCA-3A into northeast Shark River Slough (NE-SRS), and increase the capacity for freshwater inflows to NE-SRS via the Tamiami Trail road raising and 1-mile bridge construction. These projects will thereby improve hydrologic conditions in NE-SRS and will partially mitigate flooding problems in southern WCA-3A and western Shark River Slough. In addition, Taylor Slough wetlands should experience improved hydrologic regimes, and damaging flood releases to Florida Bay should be reduced.

Discharging more water south of Tamiami Trail into NE-SRS could increase the frequency and intensity of drought, peat loss, and vegetation change in northern WCA-3A, if these near-term projects are not accompanied by increased inflows into WCA-3. Even assuming that the current Integrated Delivery Schedule can be maintained and that water quality issues can be addressed (see Chapter 5), it will be at least 10 and possibly 25 years before significant new water can be provided through WCA-3 or via an eastern flow-way. In the meantime, the Florida snail kite population appears to be at high risk of extinction (Martin et al., 2007), precipitating a management crisis before CERP restoration measures are in place. In the interim, it is important to find near-term ways to improve water

BOX 4-3
Near-Term CERP and Non-CERP Projects Affecting
WCA-3 and Shark River Slough

Projects currently scheduled for completion by 2013 will

- restore flow connections between Water Conservation Area (WCA)-3A and northeast Shark River Slough (NE-SRS) by bridging and raising the Tamiami Trail (Mod Waters 1-mile bridge, under construction);
 - degrade L-67 and L-67ext levees in WCA-3 and NE-SRS (Mod Waters, partially completed) to re-connect WCA-3A and -3B and improve surface-water distribution in NE-SRS;
 - install new conveyance and seepage control structures in L-29 and L-67 levees to manage flow connections between WCA-3A, WCA-3B, and NE-SRS (Mod Waters, partially completed);
 - provide flood control in the 8.5-square-mile area (Mod Waters, completed);
 - manage eastward seepage with the S-356 and S-357 pump stations (Mod Waters, completed but not operating); and
 - develop and implement an operating plan for moving water from WCA-3A to NE-SRS (Combined Structural Operational Plan).

management practices, where practicable, to maximize restoration benefits and minimize further long-lasting impacts to these areas. These near-term efforts should make use of quantitative tools to estimate the likely reproductive success, survival, population size, condition, or extent for critical ecosystem components (e.g., snail kites, cape sable seaside sparrows, tree islands, ridge and slough patterns) under current and near-term projections of hydrologic conditions and should use the results of such analyses to inform management decisions.

Near-Term Operational Improvements

Examples of management refinements that could benefit WCA-3 are the implementation of a new rainfall-driven flow formula for Zone E releases (see Appendix D) to Everglades National Park and more flexible scheduling of S-12 gate closures under the IOP. These alternatives, described in more detail below, are being considered as part of the Everglades Restoration Transition Plan (ERTP), a multi-agency effort³ to improve water management operations concurrent with the November 2010 expiration of the biological opinion that imposes the current IOP regulation schedule (see also Chapter 3).

Since 1985, Zone E water deliveries from WCA-3A to Shark River Slough have been managed to mimic pre-drainage flow timing and volume expected from rainfall based on a simple linear regression model. This “rainfall formula” operates once water levels in WCA-3A fall below flood control levels. The allocations are based on observed flow responses to rainfall and evaporation in WCA-3A during a 1941-1952 reference period. The formula is calculated weekly, and water is released through the S-12 structures to northwest Shark River Slough (NW-SRS) or via the S-333 gated spillway to the L-29 Canal and southward via culverts under the Tamiami Trail. Recently, hydrologists at the SFWMD have developed a non-linear neural network model that outperforms the existing regression model in forecasting stage response to rainfall in WCA-3A and allows managed flows that are much closer to pre-drainage hydrology (Neidrauer et al., 2007; Ali, 2009). Even using existing control structures and operating constraints, the new rainfall formula provides improved stage forecasts that allow more rain-driven flow to Everglades National Park, resulting in a 10 percent increase in total flow to Shark River Slough and a 34 percent increase to Northeast Shark River Slough compared to the existing formula, mostly in the dry season from November to January (Neidrauer, 2009).

These changes come with a slight increase in duration of low stages in

³The main participants have been the SFWMD, U.S. Fish and Wildlife Service, the USACE, Everglades National Park, the Florida Fish and Wildlife Conservation Commission, and the Miccosukee Tribe.

WCA-3A and an increase in loading of total phosphorus to Everglades National Park, once again pointing to the multiple tradeoffs associated with changes in water management. Analyses are not available to date, however, to determine whether the new rainfall formula will promote recovery of the most endangered species in WCA-3 and Everglades National Park (kites and sparrows) or how well it supports other Everglades wildlife and ecological functioning. Moreover, in the absence of historical stage or flow data for comparison, evaluation of the efficacy of the new rainfall formula is based on comparison with recent version of the Natural System Model, which has considerable uncertainty in performance as discussed earlier in this chapter. Nevertheless, the new approach to managing rain-driven flow may be a promising way to improve water management and to deliver restoration benefits quickly prior to full project construction. The new formula could yield even greater benefits with the completion of Band 1 projects (Neidrauer et al., 2007). Given the constraints, the proposed operational changes at minimum are not expected to perform any worse than the existing operations plan (IOP) (T. Hopkins, FWS, personal communication, 2010).

Within the ERTTP effort, water managers and biologists are also reconsidering the management of the S-12 structures that discharge water from southern WCA-3A into NW-SRS. As discussed above, the opening and closing of those structures has been on a rigid calendar schedule to avoid flooding Cape Sable seaside sparrows during the nesting season, but this schedule has seriously impacted southern WCA-3A through excessive high water and rapid draw-down. The ERTTP team is considering a more flexible approach to S-12 operations that responds to the actual nesting behavior of Cape Sable seaside sparrows in Everglades National Park in a given year while also addressing resource concerns in WCA-3, such as those related to snail kites and tree islands. This more nuanced water management, combined with the new rainfall formula, could provide better water distribution and depths, balancing the needs of multiple species and ecological objectives.

System operations is also being improved through continuation of biweekly phone consultations among scientists and managers. These operations consultations consider recent precipitation and water levels across the South Florida ecosystem as they relate to target species and ecosystems and provide for real-time adjustments to operations as needed to address flood control and water supply demands, while striving to maintain optimal water management for multiple species. The calls have become more formalized over time, and each participating agency⁴ now provides written recommendations for operations in advance of the call based on the specific needs of the target species or landscape

⁴Typically including, but not limited to, the U.S. Fish and Wildlife Service, Everglades National Park, the USACE, the SFWMD, and the Florida Fish and Wildlife Conservation Commission.

components. This information is then used by USACE and SFWMD operations managers in their water management decisions. The ERTF team has encouraged the USACE and SFWMD to document the water management decisions made, so that the results are available for analysis to learn about and improve upon system operations.

These regular multi-agency consultations are a first step toward multi-species adaptive management, which is essential to restoration progress. They represent a change in the way the agencies have interacted in the past and especially in the consultation process for the U.S. Fish and Wildlife Service (FWS). Under the ERTF, consultation has moved from a retroactive process that often evaluates the ecological effects of proposed water management on listed species to determine if a jeopardy decision would occur, to a more proactive process that attempts to recover species before further population declines accrue. The committee commends this incremental multi-agency approach to improve water management and ecological conditions in WCA-3 during the transition period before significant new storage and conveyance features are built. This represents a form of incremental adaptive restoration, as proposed by NRC (2007). However, it is important that the CERP agencies seize the associated opportunities for learning from these flow modifications, so that the information can be incorporated into future system improvements.

Tools to Support Multi-Objective Management and Tradeoff Analysis

The efforts described in the previous section would benefit from a more rigorous basis for analyzing the species and ecosystem tradeoffs, which is discussed in this section. The need to develop and use tools and analyses, including examples, was discussed in NRC (2005). However, currently there are no formal decision-making tools for managing multiple species in South Florida (NRC, 2008). Multi-species and multi-objective management appears to be limited to the aforementioned interagency phone consultations to discuss possible current and future improvements to water management operations. Missing from this process are decision support tools that integrate the effects of water management decisions on multiple species and ecosystem components such as tree islands. These tools will have an especially important role to play in planning water management over the next several decades, as we await the decompartmentalization of WCA-3A and the new water sources and storage options to provide the flows needed for restoration.

The process of consultation and decision making would also benefit greatly from a clear articulation of where the hydrologic needs of Everglades target species and ecological features conflict. Because these species have life histories that have been shaped by the seasonal rhythms of water level rise and fall in

the Everglades, it has been suggested that the water management needs of key endangered species are compatible to the point that a single water management schedule would suffice for all (SEI, 2007). This might have been true before the Everglades was reduced in area and the flows were modified, but the population crash of snail kites, the fluctuations and recent expansion of wading birds, and the stability of Cape Sable seaside sparrows over the past decade suggest otherwise. Moreover, there is evidence that hydrologic needs of key Everglades species sometimes conflict. For example, nesting success of snail kites is negatively related to the rate of water recession during the breeding season, but water recession rates are positively related to the nesting success for wading birds (Frederick and Collopy, 1989). Initiating water recession in WCA-3 in October, which has been suggested to ensure the high concentrations of aquatic prey that are required by wood storks, would be unlikely to maintain the areas of flooded emergent vegetation that are required by snail kites for nesting from February through May (SEI, 2007).

Conflicts between species' hydrologic needs may also have a spatial dimension that has been created by the damming effect of the Tamiami Trail. For example, opening the S-12 gates on the western side of WCA-3 earlier in the late fall or winter to release more water into western Shark River Slough would likely have adverse impacts on Cape Sable seaside sparrow subpopulation A, but it would likely reduce the degradation of tree islands and ridge and slough landscapes within southern WCA-3A that are used for nesting and foraging by wading birds and kites (SEI, 2007).

Decision tools that create a common and comparable framework across species and Everglades ecosystem features are available in various forms, and they should be adapted as necessary and applied to more fully assess potential tradeoffs and to identify risks (NRC, 2005; SEI, 2007). These tools should support simultaneous evaluation of the effects of water management decisions on snail kites, Cape Sable seaside sparrows, tree islands, and other species or ecological processes of concern. To do so, these tools would need to directly or indirectly connect hydrology (e.g., water depths or stages, recession rates) to

(1) *habitat conditions* (e.g., in the form of Habitat Suitability Index Models (HSIs). HSIs can be graphical, logical, or mathematical models based on species-habitat relationships that can be tested and continually improved;

(2) *specific demographic rates* in the form of statistical models. For example, several snail kite demographic traits related to hydrology in WCA-3 that could form the basis of a demographic model are demonstrated in Figure 4-9; and

(3) *rates of population change* in the form of population models that integrate the effects of hydrology on changes in population size or on multiple

demographic traits that are used to calculate population change with matrix population models.

Tools would provide ways to weight the relative values of performance metrics, species, or features to quantify tradeoffs. While different kinds of decision support tools could be used for different species or processes, their results would be integrated. Using multiple models of differing complexity for the same species or features allows the triangulation of inference about management options and is increasingly seen as a useful approach to support decisions. Science managers and restoration decision makers should also take advantage of tools that already are in use, evaluate their relevance to this situation, and adapt them as needed.

CONCLUSIONS AND RECOMMENDATIONS

The reduced extent, altered topography, and reduced storage of the modern Everglades make it infeasible to achieve the same degree of restoration throughout the remnant system. Hydrologic conditions may even worsen in some areas in order to achieve desired outcomes in others. In particular, northern WCA-3A and -3B have experienced substantial drying, peat loss, and subsidence, which makes it challenging to maintain suitable water flow, levels, and hydroperiods there.

Hydrologic interdependencies of regions within the Everglades and the associated ecological tradeoffs that result from restoration and water management decisions need to be rigorously analyzed from a whole-system perspective and clearly communicated to decision makers and stakeholders. The CERP lacks a formal approach for evaluating in a transparent way the systemwide benefits of alternative restoration plans or policies, although RECOVER scientists have made good use of hydrologic models and performance measures to evaluate the design and staging of the CERP. RECOVER, in collaboration with water managers and decision makers, should develop evaluation methods to quantify and integrate across the tradeoffs required to sustain Everglades' species and features to assess the systemwide restoration benefits. Any consideration of the ecological risks associated with water management should consider the timescales over which adverse ecological outcomes might be reversible, if they are at all.

Increasing water storage (and associated water quality treatment) is a major near-term priority. Over the next 5–10 years, CERP and pre-CERP projects will improve the conveyance and distribution of water in southern WCA-3A and Everglades National Park. But until additional water of sufficient quality becomes available, the restoration benefits will be modest and could result in shorter hydroperiods and more severe dry-down events in northern WCA-2A and northern WCA-3A. The IDS does not currently have a plan for water storage

to support planned projects in the remnant Everglades ecosystem, aside from the stalled EAA A-1 Reservoir, and the benefits of the EAA A-1 Reservoir to the remnant Everglades remain unclear.

WCA-3 is a growing focus of public controversy and management concern because of its location and the way the entire system is operated to manage water distribution and quality. WCA-3A supports extensive and relatively intact landscapes including ridge and slough patterns and tree islands and provides critical habitat for endangered species, such as the snail kite and wood stork. It is the homeland of the Miccosukee Tribe of Indians and supports the tribe members' traditional and contemporary lifestyles. Over the past decade, however, there have been drastic declines in snail kite numbers and nesting success in WCA-3A, as well as continued slow declines in tree island size and number. The imminent loss of the snail kite from WCA-3A may precipitate a crisis in water management. To some degree, this situation has been exacerbated by the current operation of the compartmentalized Everglades that alters flows across the Tamiami Trail to restore Cape Sable seaside sparrows and ecosystem functioning in Everglades National Park.

In light of the rapidly deteriorating conditions in WCA-3A, improvements in operations could lead to important near-term restoration progress. The committee commends the cooperative, multi-objective approach to improve near-term operations that is reflected in the ERTF and encourages continuation of this approach, supported by rigorous scientific analysis and decision tools, beyond the November 2010 end point. This process has the potential to align water management in the water conservation areas with a schedule that responds more flexibly to real-time conditions.

Improved species models and multi-objective decision analysis tools are urgently needed to provide more rigorous scientific support for water management decisions. Multi-objective decision tools can be used to help evaluate hydrologic effects and water-level management options on threatened species, ecosystem features such as tree islands, and critical ecosystem processes.

5

Challenges in Restoring Water Quality

“Getting the water right” is a simple phrase that belies the inherent complexity of the overarching goal of the Comprehensive Everglades Restoration Plan (CERP). In Chapter 4, the committee discussed the challenges of water storage and distribution, and the necessity of making tradeoffs in the planning process to optimize the overall restoration benefits. Yet, water quality and water quantity are inextricably linked. Restoration planners cannot design projects to move large quantities of water south into the Everglades Protection Area to meet CERP goals without first ensuring that the water will meet established water quality criteria. Meanwhile, getting the water quality right has proven more difficult than originally imagined, and water quality has become a central technical, legal, and policy challenge that is affecting CERP progress.

In this chapter, the committee describes the legal context to water quality issues in the Everglades and analyzes the success of the water quality initiatives implemented to date. The committee also considers other possible water quality solutions and their cost implications. Water quality issues affecting aquifer storage and recovery (ASR) are not addressed in this chapter but are discussed briefly in Chapter 3.

PRE-DRAINAGE NUTRIENT CONDITIONS

Before construction of the canal and ditch networks began during the late 1900s, direct precipitation was the main source of water to much of the Everglades region. Although there are no water quality data extending back to that time, the general characteristics of the water quality can be reconstructed from measurements in the most interior sections of the marsh and from studies of the chemical composition of the dominant water sources. Recent hydroecological research, using a variety of methods including stable isotope analyses and chemical ratios (e.g., sulfate to chloride ratios), has demonstrated that under pre-drain-

age conditions, surface water and groundwater were relatively small components of the Everglades water inputs (see Table 4-1; Harvey and McCormick, 2009).

The rainfall input is characterized by low ionic strength (median specific conductance of <20 microsiemens per centimeter [$\mu\text{S}/\text{cm}$]) and generally low concentrations of all major ions (i.e., largely <1 parts per million [ppm, or milligrams per liter], except for sulfate and chloride, because of marine aerosol influences). Rain-fed areas of the Everglades (e.g., the interior of the Arthur R. Marshall Loxahatchee National Wildlife Refuge [LNWR]) have conductivities of <100 $\mu\text{S}/\text{cm}$. Rainfall is also notably low in nitrogen and phosphorus; estimates of phosphorus concentrations and loading in rainwater range from 30 parts per billion (ppb) (Davis, 1994) to more recent measurements of 9 to 10 ppb (Ahn and James, 2001; Richardson, 2008).

Water quality data going back to 1978 show that the interior portions of the Water Conservation Areas (WCAs) and Everglades National Park are uniformly at or below 10 ppb total phosphorus (TP). Water samples taken between 1978 and 2003 in Everglades National Park have geometric mean TP concentrations of 4.5-5.6 ppb and geometric mean total nitrogen (TN) concentrations of 0.9-1.4 ppm (Payne and Weaver, 2004). A study conducted in 1953, prior to the intensive agricultural development of the Everglades Agricultural Area (EAA) but after construction of the major canals, showed “dissolved phosphorus” concentrations of 3–7 ppb in the Tamiami Trail canal and the lower portions of the canals bordering what is now WCA-3B, with concentrations about an order of magnitude higher in samples closer to Lake Okeechobee (Odum, 1953). In the absence of explicit data from the pre-drainage period, one can assume that the rain-driven system would have had similar water quality characteristics (i.e., low alkalinity, low total nitrogen and phosphorus concentrations) derived primarily from atmospheric deposition. Any phosphorus inputs from Lake Okeechobee overflows were generally thought to have been assimilated by the former pond apple swamp that existed between the lake and the sawgrass plains (Noe et al., 2001).

LEGAL CONTEXT FOR WATER QUALITY IN THE SOUTH FLORIDA ECOSYSTEM

Water quality criteria and standards (see Box 5-1) in the South Florida ecosystem are governed by a mix of federal and state statutes, implementing regulations, and judicial consent decrees. Current and proposed standards are fiercely contested, and active litigation in federal courts continues to create uncertainty as to which regulations will apply to future restoration plans. Because these criteria and standards have important implications for the CERP as it moves forward, the current legal and regulatory context is described in this section.

Current standards, including designated uses and supporting criteria, are designed to limit the nutrient content of waters (especially phosphorus) flowing

BOX 5-1
Definitions of Water Quality Criteria and Standards

Regulatory documents commonly use the terms “standards” and “criteria.” The two terms are not synonymous. Water quality standards consist of three elements (EPA, 1998):

- 1) The designated use or uses of a water body or segment of a water body;
- 2) Water quality criteria necessary to protect the designated uses; and
- 3) An antidegradation policy.

Classes of designated uses are defined by states. In Florida, those classes are defined in Florida Administrative Code (FAC) §§ 62-302.400 as:

CLASS I—Potable Water Supplies

CLASS II—Shellfish Propagation or Harvesting

CLASS III—Fish Consumption; Recreation, Propagation and Maintenance of a Healthy, Well-Balanced Population of Fish and Wildlife

CLASS III-Limited—Fish Consumption; Recreation or Limited Recreation; and/or Propagation and Maintenance of a Limited Population of Fish and Wildlife*

CLASS IV—Agricultural Water Supplies

CLASS V—Navigation, Utility, and Industrial Use

Water quality criteria are of two forms, numeric and narrative. Numeric criteria are maximum acceptable concentrations of specific chemicals or acceptable ranges of other parameters such as temperature that will protect human health and aquatic life in a particular water body. Narrative criteria are qualitative statements such as those in FAC §§62-302.500 that all waters shall be free of substances that cause specified nuisance conditions and those that are acutely toxic.

*The Class III-Limited designation was added by the state of Florida in August 2010 and still needs EPA review and approval.

into Lake Okeechobee and the Everglades Protection Area. In general terms, one set of criteria was established for water quality within the Everglades and other standards set limits on the actual discharges of phosphorus into water bodies.

The controlling federal statute is the Clean Water Act (CWA). It requires states to establish water quality standards that will support designated uses of waterways, and it establishes a permit program for discharges of wastewater and stormwater into receiving waters of the United States. Although rather stringent limits can be placed on point sources under authority of the CWA, nonpoint sources are not subject to the federal permit program.

In 1987, the state of Florida exercised its authority to address nonpoint sources by adopting the Surface Water Improvement and Management (SWIM)

program (Florida Statute Chapter 373.453). SWIM directed Florida's water management districts to develop and implement plans to clean up and preserve the state's lakes, bays, estuaries, and rivers. SWIM also directed that the water management districts' operations not "adversely affect indigenous vegetation communities or wildlife." Thus, Florida set narrative regulatory criteria to ensure that phosphorus concentrations would cause "no imbalance in flora or fauna," which is now formalized in Florida Administrative Code (FAC) 62-302.530¹ (see also Rizzardi, 2001).

Water Quality Standards for the Everglades Protection Area

In 1988, the United States sued the state of Florida and the South Florida Water Management District (SFWMD), alleging that the state had failed to adequately clean up waters flowing into Everglades National Park (ENP) and LNWR (also known as WCA-1).² After several years of litigation the parties entered into a settlement agreement in 1991 that was implemented by a Consent Decree in 1992. The 1991 settlement agreement contained several provisions, including

- a general commitment on the part of the SFWMD and the Florida Department of Environmental Protection (FDEP) to protect water quality in LNWR and ENP,
- adoption of interim and long-term total phosphorus limits,³
- certain remedial measures,
- a research and monitoring program, and
- contingencies for enforcement.

Remedial measures included a commitment by the SFWMD to construct 35,000 acres of stormwater treatment areas (STAs) and an interim and long-term regulatory program to require permits on all discharges from the EAA. Interim regulations for the EAA were to require a 10 percent reduction in phosphorus loads,

¹Florida's narrative water quality criterion for nutrients provides that "in no case shall nutrient concentrations of a body of water be altered so as to cause an imbalance in natural populations of aquatic flora or fauna." (F.A.C. rule 62-302-530(47)(b)).

²*United States v. South Florida Water Management District*, 847 F. Supp. 1567 (S.D. Fla. 1992).

³Interim limits for phosphorus were to be achieved by July 1997 (later amended to October 2003), including annual flow-weighted concentration goals in Shark River Slough of no more than 14 ppb in a dry year and 9 ppb in a wet year. Long term limits were to be achieved by 2002 (later amended to 2006) including annual flow-weighted concentration goals in Shark River Slough of no more than 13 ppb in a dry year and 8 ppb in a wet year, and the long-term concentration limit for Taylor Slough and the Coastal Basins was set at 11 ppb. Interim and long-term limits for Everglades National Park and LNWR were specified by complex formulas in Appendices A and B of the Settlement Agreement. Interim levels for LNWR were to be between 8 and 22 ppb depending on water levels as measured.

and the long-term regulations were to require source control efforts resulting in a 25 percent reduction.

The state of Florida took action in 1994 to implement the primary features of the 1992 Consent Decree with enactment of the Everglades Forever Act (Fla. Stat. §373.4592). A crucial feature of the act directed the FDEP to develop numeric criteria for phosphorus within the Everglades Protection Area, defined as WCAs 1 (LWNR), 2A, 2B, 3A, and 3B, and Everglades National Park (FAC §§ 62-302.540). However, the Act provided that if no phosphorus criterion was adopted by the end of 2003, a 10 ppb criterion would automatically take effect in 2004 (see Fla. Stat. § 373.4592(10)). Scientific support for that criterion, added to the administrative code in July 2004, is discussed in Box 5-2. Modifications to the Consent Decree⁴ in 2001 deferred the compliance date for long-term phosphorus limits to 2006.

The state of Florida amended the Everglades Forever Act in 2003 and formally adopted the revised phosphorus rule (FAC §§ 62-302.540).⁵ That rule states that for Class III waters in the Everglades Protection Area, the phosphorus criterion is a long-term geometric mean of 10 ppb, but not lower than natural conditions, taking into account temporal and spatial variability. Achievement of the criterion in Everglades National Park is governed by methods in Appendix A of the 1991 Settlement Agreement, and achievement of the criterion in the WCAs is evaluated across a network of sampling stations using a four-part test⁶ to determine whether a violation of Class III standards has occurred. Current methods for calculating values for Consent Decree compliance in LWNR and Everglades National Park, considering interannual variations in water levels, are described in the December 2009 report of the Technical Oversight Committee (SFWMD, 2009b).

Several important changes were also made in the 2003 Everglades Forever Act amendments. Long-term permit conditions were modified, and new “Technology-based Effluent Limitations (TBELs) established through Best Available Phosphorus Reduction Technology (BAPRT)” were established to govern STA discharges (FAC §§ 62.302.540). Water-quality-based effluent limitations were held in abeyance until 2016. In addition, paragraph (6) allows net improvement as a moderating provision for “impacted” areas, where those areas are defined as being in the Everglades Protection Area with total phosphorus concentrations in the upper 10 centimeters of the soils greater than 500 milligrams per kilogram.

⁴See http://exchange.law.miami.edu/everglades/litigation/federal/usdc/88_1886/orders/2001_amend_Settlement_Agreement.pdf.

⁵See also *Miccosukee Tribe of Indians of Florida v. United States*, 2008 WL 2967654 (S.D. Fla.).

⁶The four-part test is used to assess compliance according to the following four provisions: (1) five-year geometric mean is less than or equal to 10 ppb, (2) annual geometric mean averaged across all stations is less than or equal to 11 ppb, (3) annual geometric mean averaged across all stations is less than or equal to 10 ppb for three of five years, and (4) annual geometric mean at individual stations is less than or equal to 15 ppb (FAC §§ 62.302.540).

BOX 5-2
Scientific Support for the 10 ppb Criterion

The determination of the 10 ppb total phosphorus (TP) criterion was based on extensive research (McCormick et al., 1999; Payne et al., 2001, 2002, 2003; reviewed in Noe et al., 2001; Richardson, 2008). The data overwhelmingly demonstrate that even low levels of enrichment in total phosphorus concentrations result in elevated phosphorus in macrophyte tissues, soil, the water column, and periphyton, leading to undesirable changes in periphyton and macrophyte biomass and productivity and faunal communities.

Under pre-disturbance conditions, isolation of the surface-water system from bedrock meant that the only significant inputs of phosphorus were from atmospheric sources, estimated to be in the range of 0.03 grams per m² per year (Noe et al., 2001). In interior (undisturbed) portions of the Everglades, phosphorus concentrations in plant and periphyton biomass and in soil are very low compared to other wetlands and other peatlands, and the nitrogen:phosphorus ratios in these compartments suggest extreme phosphorus limitation, which Noe et al. (2001) ascribe to several factors, including

- its occurrence on a limestone platform, which promotes removal and sequestration of phosphorus through abiotic chemical reactions;
- the very large spatial extent of the system, such that groundwater from other regional sources are isolated from all but the periphery of the system and most of the system receives the bulk of its nutrients from precipitation (ombrotrophic);
 - conservative cycling of phosphorus by the dominant macrophytes;
 - periphyton mats that maintain highly oxidized sediments, so that any phosphorus becomes adsorbed to iron minerals and is not bioavailable; and
 - the ability of Everglades plants (notably, *Cladium*, *Eleocharis*, and related species) to grow at unusually low tissue phosphorus concentrations.

These changes were challenged by the Miccosukee Tribe in the U.S. District Court as violating both the 1992 Consent Decree and the federal CWA. In July 2008, the court agreed that the changes (e.g., deferrals) violated the CWA, enjoined the FDEP from issuing any permits under the revised program, and ordered federal EPA to rigorously review the state program to ensure compliance with the CWA. The effect of this ruling was to effectively reinstate the 10 ppb rule and other features of the 1992 Consent Decree and the 1994 Everglades Forever Act. Subsequently, in April, 2010, the court reaffirmed that deferring compliance until 2016 violated federal law. New orders were issued for EPA to issue instructions to compel the state of Florida to comply with the 10 ppb criterion and for the State to complete new rulemaking to that effect in early 2011.⁷

⁷*Miccosukee Tribe of Indians of Florida v. United States of America*, Lead Case No. 04-21448-CIV-GOLD; Order Granting Plaintiffs' Motions in Part; Granting Equitable Relief, Requiring Parties to Take Action by Dates Certain, April 14, 2010.

Water Quality Standards for Lake Okeechobee and Tributaries

Section 303(d) of the CWA requires that when a water body does not meet applicable water quality standards, the state or U.S. Environmental Protection Agency (EPA) must set numeric limits on point and nonpoint source discharges to assure that the water body will satisfy the standards. Following a 1999 Consent Decree,⁸ Florida enacted the Lake Okeechobee Protection Act in 2000 (Chapter 00-103, Laws of Florida), requiring limits on phosphorus inflows into the lake. FDEP developed and EPA approved a phosphorus total maximum daily load (TMDL) for Lake Okeechobee of 140 metric tons (mt) annually (105 mt from nonpoint surface runoff and 35 mt from atmospheric deposition; FDEP, 2001; Chapter 62-304, Laws of Florida). In addition, the rules prescribed a 40 ppb TP goal for the pelagic zone in the lake, and a target of 113 ppb was established for the lake's tributaries, as recommended by FDEP, to provide protection of aquatic life within each tributary while maintaining consistency with the Lake Okeechobee TMDL (EPA, 2008a). The 113 ppb target was selected for the Lake Okeechobee tributaries as a numerical interpretation of Florida's narrative criterion until a numeric criterion was developed. In March 2009 a group of environmental organizations filed suit challenging the EPA action and arguing that the "interim" TMDL violates the CWA.⁹ This case is pending.

Statewide Numeric Limits for Nutrients

Recent actions have been taken to establish statewide numeric criteria for nutrients (i.e., phosphorus and nitrogen) in Florida's waters. In 1998 EPA formulated a national strategy for development of regional nutrient criteria (EPA, 1998). In doing so it cited evidence that nutrients were among the leading causes of impairment in rivers, lakes, and estuaries, and noted that 51 percent of lakes and 57 percent of the nation's estuaries were impaired by over-enrichment of nutrients (EPA, 1996). At the time the only national criterion for nitrogen was a health-based limit for the protection of domestic water supplies, and the only national phosphorus criterion was based on "a conservative estimate to protect against the toxic effects of the bioconcentration of elemental phosphorus to estuarine and marine organisms." That strategy was revisited in 2007 (EPA, 2007). A 2008 national status report on numeric nutrient criteria showed that 31 states had no numeric criteria for nutrients in lakes and reservoirs, 36 had none for rivers and streams, and half of the 24 states with estuaries had none (EPA, 2008b).

⁸See *Florida Wildlife Federation v. Carol Browner*, No. 4:98CV356-WS (N.D. Fla. Tallahassee Div., April 22, 1998).

⁹*Florida Wildlife Federation, et al v. The United States Environmental Protection Agency*, Case 4:09-cv-00089-SPM-WCS (N.D. Fla.).

FDEP began development of statewide numeric nutrient criteria in 2002, soon after reaching agreement with EPA on a plan for the process. A technical advisory committee was appointed and met 22 times between 2002 and 2010 (FDEP, 2009). A lawsuit over the lack of progress prompted EPA to intervene, and in August 2009, EPA entered into a phased Consent Decree to settle the suit.¹⁰ EPA committed to propose numeric nutrient criteria for lakes and flowing waters in Florida by January 14, 2010. Proposed criteria for lakes, flowing waters, springs, and South Florida canals were published in the *Federal Register* on January 26, 2010 (75 FR 4174-4226). The approach and the criteria are summarized in Box 5-3. EPA intends to issue a final rule for lakes and flowing water (outside of South Florida) by November 15, 2010, and by August 2012 for estuarine and coastal waters and South Florida canals, unless Florida submits and EPA approves state numeric nutrient criteria before a final EPA action.

The implications of the new statewide numeric nutrient criteria are uncertain at the time of this report, most importantly because the proposed criteria for lakes, flowing waters, springs, and canals are subject to change during the public comment period. Proposed criteria for estuaries are not scheduled for publication until 2011. Additional determinations will also be needed regarding which data are to be used in analyses and evaluated against the criteria.

Proposed nutrient limits for South Florida canals (42 ppb TP, 1.6 ppm TN, 4 ppb chlorophyll a) could present yet another challenge to management of the system, depending upon how these criteria are enforced and how the Class III-limited designation (see Box 5-1) is applied. A requirement for all canals to achieve these nutrient concentrations would require significant changes in current nutrient control and treatment efforts at immense cost.

Water Quality Standards: Attainability and Cost

The CWA established water quality standards to protect aquatic life and human health without regard to available technology and the cost associated with attaining the standards. The cost of attaining and maintaining the standards may be considered during formulation and implementation of water quality management programs, but options for doing so are quite burdensome.

As discussed later in this chapter, attaining water quality standards in the Everglades system may take decades of sustained effort at very substantial costs. In proposing numeric nutrient criteria for Florida, EPA requested comments on a possible new option, a “restoration water quality standard” for impaired waters that would enable the state to take incremental steps toward attainment

¹⁰*Florida Wildlife Federation et al. v. Stephen L. Johnson and the U.S. Environmental Protection Agency*, No. 4:08-cv-324-RH-WCS (N.D. Fla.).

BOX 5-3
EPA Proposed Numeric Nutrient Criteria
for Lakes and Flowing Waters

The U.S. Environmental Protection Agency (EPA) used correlations between nutrients and biological response parameters to derive nutrient criteria for lakes using stressor-response models. EPA concluded that relationships between nutrients and chlorophyll-a in Florida's rivers and streams were affected by so many variables that derivation of reliable criteria using models was not possible. EPA chose instead to use the statistical distribution-reference site approach for those water bodies as the better basis for setting criteria. Numeric criteria were also derived for springs and clear streams. They were derived from laboratory and field investigations that supported development of a dose-response model for nuisance algal and periphyton responses to doses of nitrite and nitrate nitrogen. Criteria for canals in South Florida were derived using the statistical distribution approach (see 75 FR 4174-4226 and EPA [2010] for more details).

Proposed criteria for the Peninsula watershed region, which includes the Caloosahatchee, St. Lucie, and Kissimmee watershed, are instream limits of 0.107 ppm for total phosphorus (TP) and 1.205 ppm for total nitrogen (TN) based on an annual geometric mean not to be surpassed more than once in a three-year period. In addition, the proposed criteria state that the long-term average of annual geometric mean values shall not surpass the listed concentration values. The 10 ppb TP criterion for the Everglades Protection Area was not affected by the proposed rule. A protective TN and TP load for Lake Okeechobee also was not calculated, because a total maximum daily load (TMDL) is in effect for TP. Numeric criteria for canals in the South Florida bioregion were proposed as 42 ppb TP, 1.6 ppm TN, and 4 ppb chlorophyll a (75 FR 4174-4226). Criteria for canals are applicable to all Class III canals in the South Florida bioregion as shown in Figure 5-1 except for canals within the Everglades Protection Area, where the TP criterion of 10 ppb currently applies.

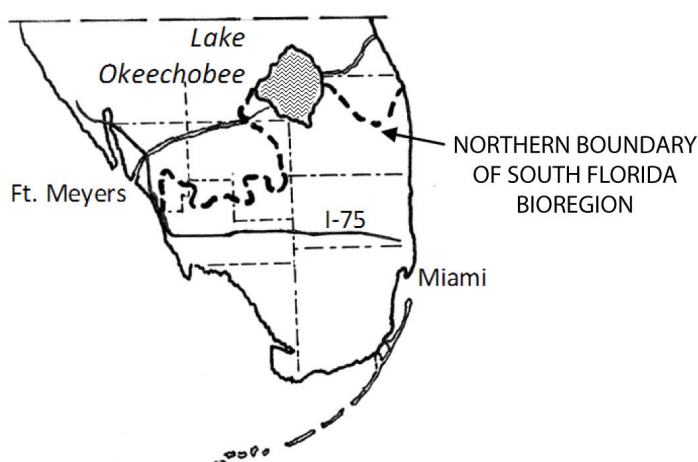

FIGURE 5-1 South Florida bioregion.

SOURCE: ftp.epa.gov/wed/ecoregions/fl/fl_eco_lg.pdf.

of permanent standards over a stated time period. EPA provided an example of an interim standard that would require progress during years 1-5, a more stringent interim standard during years 6-10, and attainment of the permanent standard beginning in year 11 (EPA, 2010). That particular option would not be applicable to the phosphorus standard in the Everglades Protection Area, which is explicitly excluded under EPA's current proposal for Florida. Implementing a similar strategy in the Everglades Protection Area would require significant changes to existing policy.

The CWA offers to states two options to address an unattainable standard, namely the use of attainability analysis and discharge-specific variances, neither of which may be appropriate to the Everglades ecosystem. A state can remove a designated use, other than an existing use, if it can demonstrate through a formal use attainability analysis that attaining the standard is not feasible for one of several reasons, including cost and widespread economic impacts. When implementing changes through a use attainability analysis, a designated use for a particular water body is changed, not the criteria applicable to the original class of uses. Because criteria are specific to designated uses, however, a change in use may trigger a change in applicable criteria. In August 2010, FDEP amended FAC Rules 62-302.400 and 62-302.530 to refine the existing surface-water classification system, creating a new sub-classification of waters, Class III-Limited would be applicable to wholly artificial waters or altered waters: Thus, a new set of criteria applicable to the new class of waters will have to be established. The implications of this change for water quality management in the Everglades system are not clear at this time. Discharge-specific variances, normally applied to municipal and industrial point source discharges, have not been applied to discharges from permitted sources within the Everglades and are therefore an untested option. Under Florida rules, an affected party may also petition for site-specific alternative criteria (SAC) when "a water body, or portion thereof, may not meet a particular ambient water quality criterion specified for its classification, due to natural background conditions or man-induced conditions which cannot be controlled or abated" (FAC 62.302.800). No such petition has been requested for phosphorus in the Everglades Protection Area (E. Marks, FDEP, personal communication, 2010).

TOWARD A SYSTEMWIDE PHOSPHORUS BUDGET

Phosphorus is the primary nutrient of concern in the Everglades system. Therefore, it is especially important that the storage and transport of phosphorus through the system be understood in considerable detail if water quality concerns are to be addressed effectively and comprehensively.

Stored Phosphorus in the South Florida Ecosystem

Phosphorus retention is an important function in basin nutrient cycling. Phosphorus can be stored over the short term in above- and below-ground plant tissues, microorganisms, periphyton, and detritus. Over the long term, phosphorus can be stored in inorganic and organic soil particles and organic matter. The fate of phosphorus in these long-term storage compartments needs to be considered in any comprehensive water quality management approach. In the Lake Okeechobee basin, Reddy et al. (2010) estimated TP storage in upland and wetland soils to be 215,000 mt.¹¹ Approximately 80 percent of the stored phosphorus (or 169,800 mt) is located in soils and stream sediments, with the remainder stored in lake sediments in the Upper Chain of Lakes, Lake Istokpoga, and Lake Okeechobee.

Reddy et al. (2010) performed a thought experiment that illuminates the long-term role of stored (or legacy) phosphorus on loading to Lake Okeechobee. Based on chemical extraction tests, they assumed that approximately 35 percent of the phosphorus stored was stable (i.e., not able to be released) because it was not soluble either in acid or base or both. Reddy et al. (2010) conservatively estimated that 10 to 25 percent of the reactive phosphorus in the soils was available to be exported from the system (see Figure 5-2). Given estimates of phosphorus leaching rates from stored phosphorus in the Lake Okeechobee basin of 500 mt per year (estimated based on assessments of long-term phosphorus discharges into Lake Okeechobee) and the estimates of stored reactive phosphorus, legacy phosphorus could maintain a phosphorus load to the lake of 500 mt per year for the next 22 to 55 years. This loading rate only considers legacy phosphorus stored in the soils and sediments and does not take into account new phosphorus additions in the basin. A recent report suggests that 11,000 mt of phosphorus is currently imported annually into the basin, and 6,700 mt is exported out of the basin, resulting in 5,300 mt net phosphorus accumulation in the system (SFWMD, 2010b).

Internal loads from sediments in Lake Okeechobee to the water column are also significant, especially from the mud zone sediments. These sediments are fine grained and are readily suspended into the water column. Based on several earlier research reports, internal flux from mud sediments to the water column was estimated at 112 mt of phosphorus per year. Based on the available reactive phosphorus in the sediments (using the assumptions described above), this supply will continue for 12 to 31 years (Figure 5-2). Managing internal load through chemical amendments may not be cost-effective considering the size of

¹¹One metric ton equals 2,200 pounds.

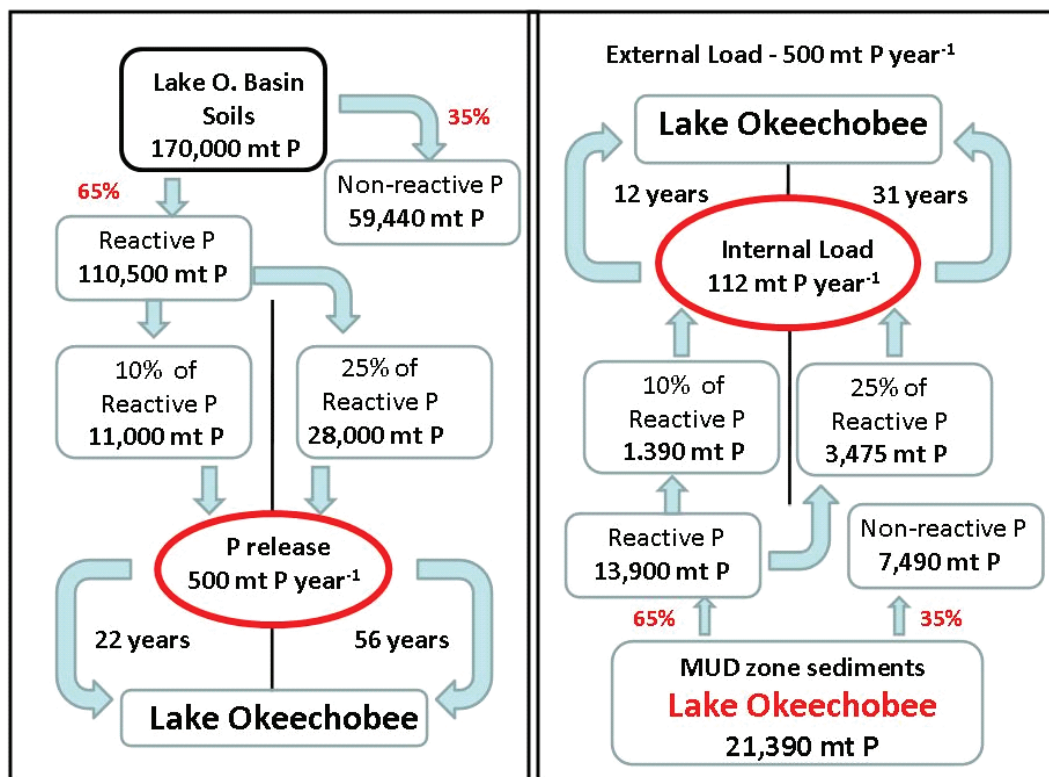

FIGURE 5-2 Role of legacy phosphorus in Lake Okeechobee and its basin in determining the lag time for recovery.

SOURCE: Modified from Reddy et al. (2010).

the lake (discussed later in this chapter). If external loads are curtailed to TMDL levels (140 mt per year), then it is likely that the lake would recover in the next 10 to 20 years and reach an alternate stable condition.

Tracking Phosphorus Fluxes in the South Florida Ecosystem

Annual average inflows and outflows of phosphorus over water years 2005-2009 are shown in Figure 5-3 for the principal components of the South Florida ecosystem. More than 500 mt per year entered Lake Okeechobee from its various tributaries during that five-year period. About 250 mt per year were released to the St. Lucie Canal, the Caloosahatchee River, and the L-8 basin. On average,

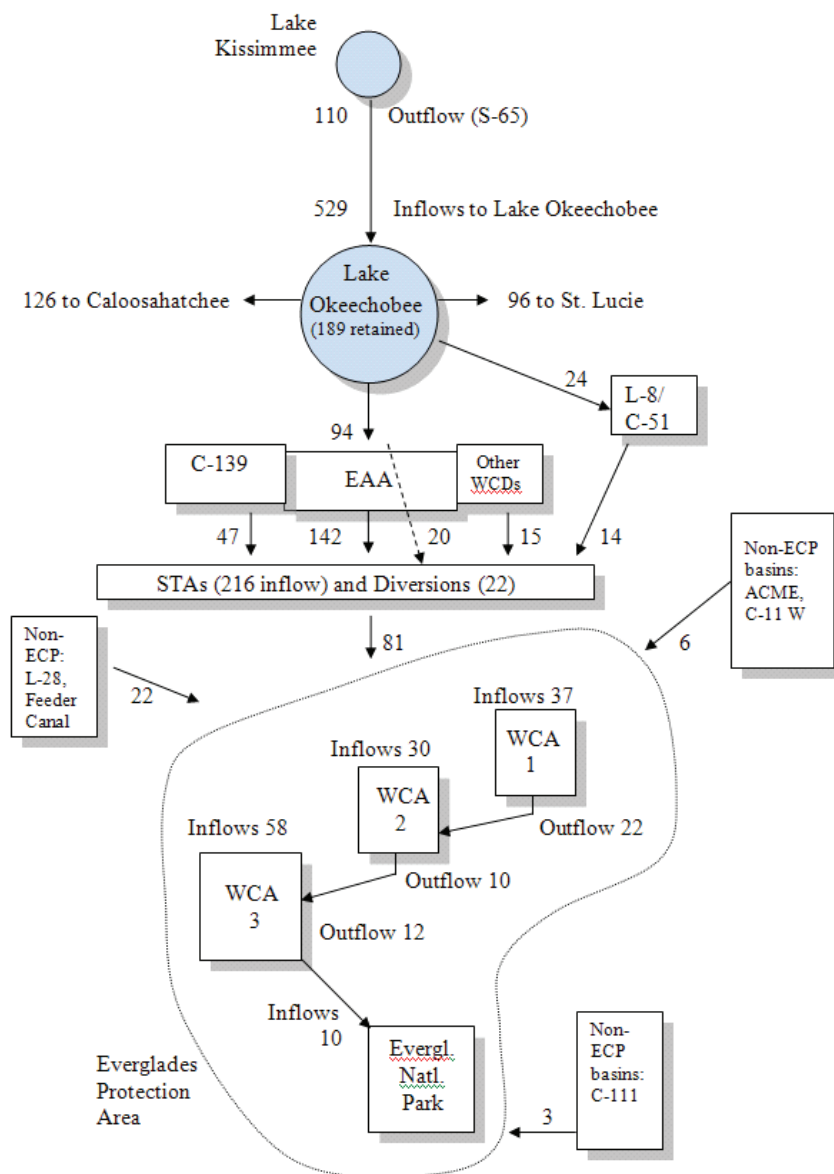

FIGURE 5-3 Average annual total phosphorus loading across the South Florida ecosystem for water years 2005-2009. Units are mt per year. WCD = water control district; ECP = Everglades Construction Project.

SOURCE: SFWMD and FDEP (2008b); Xue (2009, 2010), S. Van Horn, SFWMD, personal communication, 2010.

94 mt per year were released to the EAA. Outflows from the EAA then flowed through a complex set of pathways, including via STAs (discussed later in this chapter) into the WCAs, which also received substantial inputs from atmospheric sources. A large part of those loads were retained within the WCAs. Just over 10 mt flowed into Everglades National Park from WCA-3.

The SFWMD and FDEP have developed an impressive database on both flows and nutrients at numerous locations throughout the system, which are reported annually in the South Florida Environmental Reports (SFERs). Annual fluxes by structure in the 2009 SFER report (e.g., Appendix 3A-5 [Xue, 2009]) provide very useful but incomplete views of the transport of phosphorus through the system. It is difficult to determine several important linkages within the system from the published results. In particular, phosphorus budget linkages between Lake Okeechobee, the EAA, and the STAs are difficult to extract from reported data; therefore, linkages are critical to a more complete understanding of the system. Understanding these linkages is also essential for evaluating efficiencies of BMPs and setting priorities for additional approaches to phosphorus management. For example, in the 2009 SFER (Van Horn et al., 2009), analysis of management practices in the EAA is based entirely on discharge measurements and how they compare to 1978-1988 baseline values; there is no estimate of phosphorus inputs to the EAA from Lake Okeechobee, no estimate of commercial fertilizer applied to the EAA, and no estimate of atmospheric deposition to the EAA. The “loading rates” per land area that are discussed in the 2009 SFER and in the following section of this report appear to be runoff rates, not input loads. The lack of data about land use and inflows to the EAA is in sharp contrast to detailed information about inflows to Lake Okeechobee in the 2009 SFER (Zhang et al., 2009).

Detailed diagrams produced by the SFWMD during the preparation of this report showed inputs to the 6 STAs coming from 11 different sources, including the lake, drainage from 4 subareas of the EAA, and 6 sub-basins. Mass balances do not exist for either the EAA subareas or the sub-basins, and connections between subareas/sub-basins and the STAs are incomplete. Data on atmospheric deposition of phosphorus is only available for the Lake Okeechobee basin, and, based on 2005 reported data, atmospheric deposition appears to be a sizeable component of the phosphorus load in the Everglades Protection Area. Elimination of those information gaps is necessary to construct a more complete understanding of the flow of phosphorus through the Everglades system.

EFFECTIVENESS OF CURRENT PHOSPHORUS MANAGEMENT PRACTICES

Phosphorus in the South Florida ecosystem is currently managed through

multiple approaches, including source controls north and south of Lake Okeechobee, STAs, and treatment measures on Lake Okeechobee itself. In the following section, the committee reviews the effectiveness of the current practices and the potential for additional phosphorus removal by these practices. Preliminary cost data for the various phosphorus management practices, when available, provide an initial indication of the relative cost of phosphorus control. Phosphorus management practices vary in geographic scale, applicability, effectiveness, and obtainable end concentrations (i.e., some practices on their own cannot obtain end concentrations of 10 ppb). The cost and complexities associated with phosphorus management provide context for the committee's recommendation for a comprehensive, systemwide, cost-effectiveness analysis. The intent of such an analysis would be to look for the least costly combination of phosphorus management practices needed to meet water quality restoration goals. The recent deterioration in both state and federal finances further underscores the need for cost-effective approaches to restoration.

Source Control Strategies

One of the approaches for improving and maintaining water quality in the South Florida ecosystem has been the implementation of source controls, or BMPs. BMPs are applied to both agricultural and non-agricultural lands, and on both field and watershed scales. Examples of BMPs include improved nutrient management practices, fencing cattle out of waterways (with provision of alternative water sources for cattle), sediment and erosion control measures, use of conservation and riparian buffers, increased wetland and ditch water retention, improved irrigation management, and controlled drainage. Implementation strategies vary among watersheds and even among the basins in each watershed, depending on water quality goals for the watershed or basin, attainment status of meeting the water quality goal, and statutory requirements. BMPs are implemented throughout the South Florida ecosystem (see Figure 5-4), and recent progress on the SFWMD's efforts with respect to BMPs both north and south of Lake Okeechobee is well documented in Van Horn and Wade (2010).

Source Control and Treatment in the Northern Everglades

Historically, water flowing into Lake Okeechobee was derived primarily from the Kissimmee River, whose extensive wetland floodplain filtered nutrients from the water. Most of the current external phosphorus load to Lake Okeechobee comes from agricultural and urban land uses, and phosphorus is added to uplands in fertilizers, organic solids (e.g., sewage sludge, animal

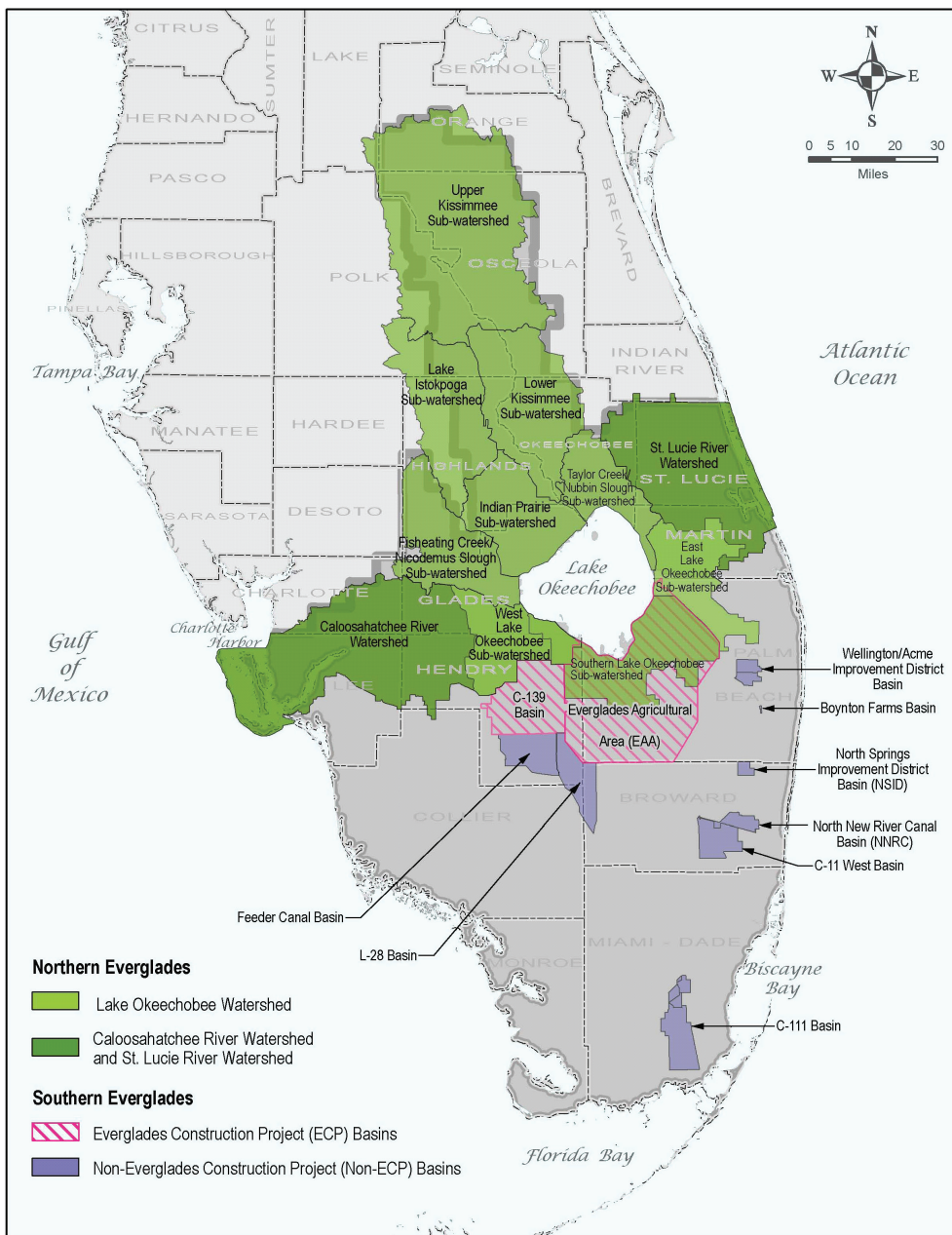

FIGURE 5-4 Location of source control basins within the South Florida ecosystem.

SOURCE: SFWMD (2009c).

wastes, composts, crop residues), wastewater, and animal feeds. Some of the phosphorus is exported from the drainage basin as agricultural products (i.e., harvested biomass), but a significant amount of the phosphorus applied to the land ends up in upland soils and sediments of ditches and streams, and a portion is then transported southward by river flow.

During the past several decades a variety of federal and state agricultural programs have been developed in an effort to reduce the fluvial transport of phosphorus from watersheds that discharge into Lake Okeechobee. One of the most important was the Lake Okeechobee Protection Act (LOPA), enacted by the Florida legislature in 2000, which mandated preparation of a comprehensive plan to meet the TMDL of 140 mt per year of total phosphorus by 2015. The plan, known as the Lake Okeechobee Protection Plan (LOPP), was published in 2004 and relied on several ongoing projects, expansion of cost-share programs to all agricultural activities, regional structural measures, and CERP reservoirs, STAs, wetland restoration, and removal of phosphorus-rich sediment from tributaries. The Northern Everglades and Estuaries Protection Program was established by the state of Florida in 2007 to strengthen protection of the northern Everglades, including the estuaries, and to expand the use of the state's Save Our Everglades Trust Fund for use toward restoration of the northern Everglades. In February 2008, the SFWMD released the Lake Okeechobee Watershed Construction Project: Phase II Technical Plan, a comprehensive plan to implement the Northern Everglades and Estuaries Protection Program. The preferred plan identifies a combination of STA construction, agricultural and urban BMP implementation, ecosystem services projects, chemical and wetland treatment projects, as well as other projects for increasing water storage north of the lake. All watersheds that flow toward the lake are covered by the plan.

Agricultural acreage accounts for 46 percent of the land area in the Lake Okeechobee watershed, and 38 percent of the agricultural acreage have completed nutrient management plans and BMPs in various stages of implementation (McCormick et al., 2010). The majority of this acreage lies within the four basins located north of Lake Okeechobee that have been identified as SWIM program priority basins (S-191, S-154, S65-D, and S-65E), where phosphorus reduction efforts are concentrated. Unfortunately, despite the use of BMPs, it is not apparent that any improvement in water quality is occurring at the basin scale. In fact only one sub-basin, S-154, shows any water quality improvement to date (B. Waylen, SFWMD, personal communication, 2010). At some locations, on-site monitoring at the farm level shows improvement for some practices, particularly for intensive land uses, such as dairies where chemical treatment systems, stormwater management, and reuse systems have been implemented. Legacy phosphorus issues and the topography of the Lake Okeechobee watershed (flat topography with significant year-to-year climate

variability, many individual ditch drainage systems) make it difficult to monitor and assess the performance of the specific BMPs that are implemented on individual farms and ranches.

As indicated in the Northern Everglades Phase II Technical Plan, an aggressive combination of agricultural and urban BMPs, payment to landowners for ecosystem services beyond basic agricultural BMPs, regional and subregional treatment systems, and intensive chemical treatment of surface-water flows to the lake will be required to improve the water quality enough to meet the established TMDL. Unfortunately, because of budget limitations very few elements of the Phase II Technical Plan have been designed, and even fewer are operational. Thus progress on reducing phosphorus loads from the Lake Okeechobee watershed to the lake has not yet been achieved. In water year (WY) 2009, the total waterborne phosphorus load to Lake Okeechobee was 680 mt, which is greater than the 580 mt average over the historical baseline period (1991-2005) and approximately 6.5 times greater than the target waterborne TMDL of 105 mt per year (see also Figure 2-15; McCormick et al., 2010). Meanwhile, the average phosphorus concentration in the pelagic zone of the lake was 162 ppb, four times the target concentration of 40 ppb (McCormick et al., 2010).

Northern Everglades Source Control and Treatment Costs. Preliminary overall cost estimates were provided for the initial implementation stages of the Phase II Technical Plan, including both water storage and water quality treatment: \$260-\$320 million in non-CERP costs and \$1-\$1.4 billion in CERP costs (SFWMD, 2008). However, no comprehensive cost-effectiveness analysis is reported, nor is a cost estimate provided for water quality measures alone. Because of a lack of state funding, little additional progress has been made on the broad northern Everglades initiative in the past two years. However, with additional cost analyses, the Northern Everglades Technical Plan (SFWMD, 2008) could provide an important basis for understanding the costs and benefits of phosphorus control and treatment measures in the northern portion of the South Florida ecosystem.

As recommended in NRC (2008), the committee encourages the SFWMD to continue the local- and regional-scale monitoring and modeling required to quantify the cost, water storage, and phosphorus reduction and associated uncertainty levels associated with each component of the Phase II Technical Plan. Note that the often substantial uncertainty surrounding the technical effectiveness of many of these source control practices complicates cost-effectiveness calculations. However, this information is essential to management decisions focused on bringing the watershed into compliance with the TMDL and on systemwide water quality.

Best Management Practices South of Lake Okeechobee

BMPs south of Lake Okeechobee (i.e., the EAA, C-139, and non-Everglades Construction Project [ECP] basins) have a significant effect on water quality in the Everglades Protection Area. As noted in Figure 5-3, the EAA, C-139, and associated water conservation districts discharge an average annual load (based on 2005–2009 data) of 224 mt TP, and non-ECP basins discharge 31 mt TP into the STAs or the Everglades Protection Area. The EAA and C-139 basins discharge 142 mt and 47 mt TP, respectively (see Figure 5-3).

The 1994 Everglades Forever Act mandated a regulatory phosphorus source control program within the ECP and non-ECP basins (Figure 5-4) and a monitoring program to assess effectiveness. The act established a phosphorus load reduction target in the EAA of 25 percent (compared to baseline [1978–1988] loads) and created tax incentives to encourage BMP implementation.

Results from the EAA source control program are impressive (see Figure 5-5). Reduction in phosphorus loads exceeded the targeted 25 percent in 13 of 14 years following implementation of a full complement of BMPs in 1996. On average, the reduction in annual TP load was more than 54 percent (or 2,118 mt) over the 14-year period (1996–2009), compared to that predicted for each year without BMPs in place (Van Horn and Wade, 2010).

In contrast, compliance in the C-139 basin, which is simply mandated to not exceed baseline phosphorus loads, has not been as successful. In six of the past seven years, the C-139 basin has failed to meet TP loading targets, with WY 2008 as the only exception.

Several factors contribute to the differences in source control program effectiveness in the EAA compared to the C-139 basin. First, the flat topography and elaborate water drainage systems in the EAA, consisting of parallel open ditch drains, main canals, and a network of pumps and weirs, allow for controlled drainage and subirrigation. These structures make it possible to hold water back in the fields, raise water tables, increase evapotranspiration, and reduce outflows and TP losses. In contrast, the C-139 basin has greater differences in surface elevation and mostly natural drainage through sloughs and creeks. Such systems are more difficult to manage and to gauge than the intensively engineered network on the EAA. Furthermore, the C-139 basin primarily contains sandy (mineral) soils, more like those of the basins north of Lake Okeechobee than the organic (muck) soils of the EAA. Typically, sandy soils are less able than organic soils to retain nutrients. Thus any fertilizer nutrients added to these soils potentially can be transported into adjacent water bodies.

Differences in land use between the EAA and C-139 basins could also explain part of the difference in their response to BMPs. The primary crop in the EAA is sugar cane, which requires relatively low phosphorus fertilization (Mor-

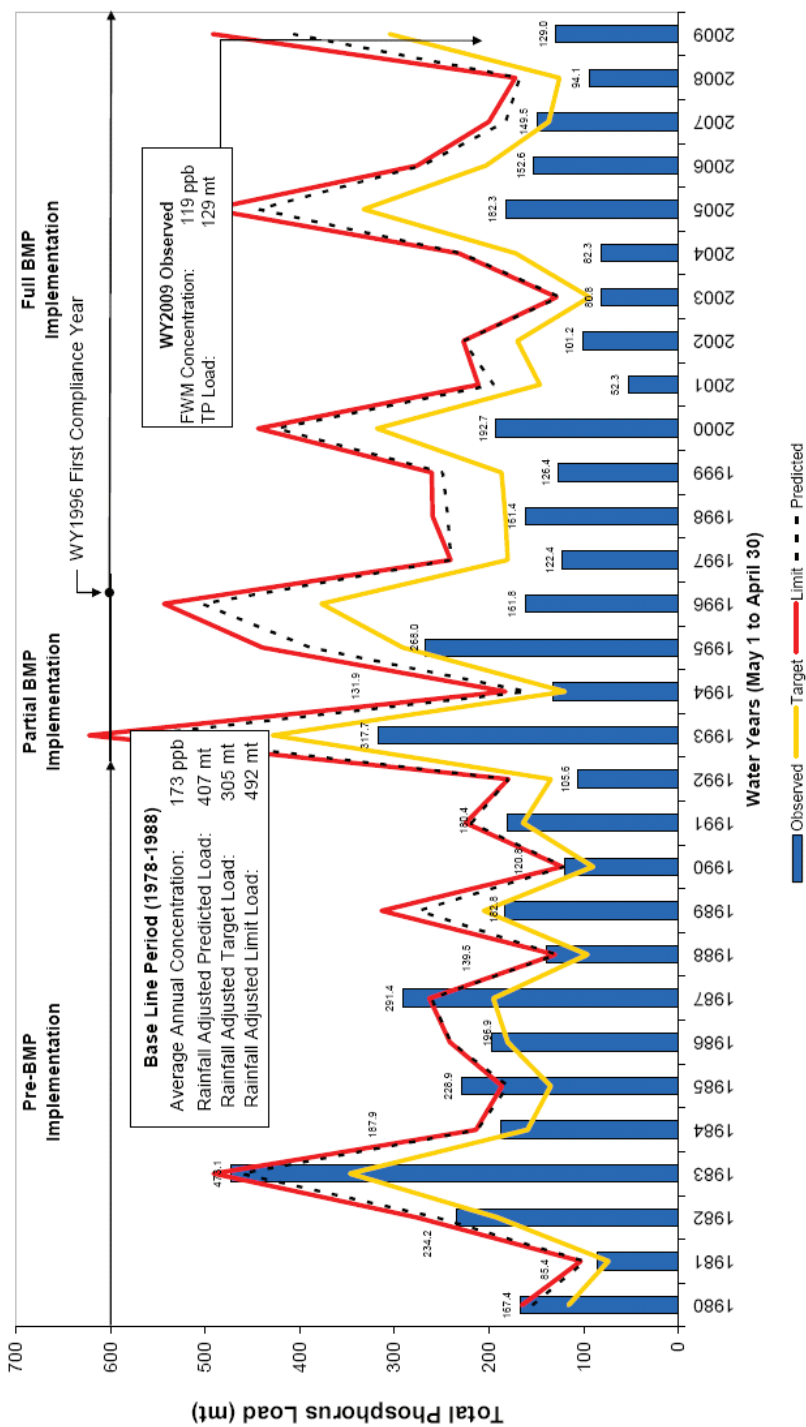

FIGURE 5-5 EAA basin observed (measured) total phosphorus loads compared to predicted (calculated) rainfall adjusted target loads (25 percent reduction from baseline loads and limit loads).

SOURCE: Van Horn and Wade (2010).

gan et al., 2009) and is tolerant of a range of water table depths. Consequently, controlled drainage in the EAA can reduce drainage flows and phosphorus losses without reducing yields. Sugar cane is also grown in the C-139 basin, but its primary land uses are pasture (68 percent), row crops (11 percent), and citrus (10 percent) (based on 2004 data; R. Budell, Florida Department of Agriculture and Consumer Services, personal communication, 2010). Although pastures produce low phosphorus loads relative to other land uses (Table 5-1), BMPs to effectively reduce phosphorus losses from this diffuse source are difficult to apply. Between 1995 and 2004, the acreage of land used for agriculture in the C-139 basin increased by 7 percent, compared to a 6 percent decrease in the EAA. During this same time period, data show a 60 percent increase in row crops in the C-139 basin, a land use with much larger phosphorus loads than other agricultural land uses (Table 5-1; R. Budell, Florida Department of Agriculture and Consumer Services, personal communication, 2010). Additionally, compared to the EAA's, the C-139 basin's monitoring network and baseline rainfall data are not as extensive, which reduces the reliability of its model predictions.

Assessment of the compliance of each basin is based on monitoring phosphorus loads at the basin level, not at the farm level. However, to ensure that BMP plans between different permittees are comparable and equitable, a system of BMP equivalents was developed by assigning points to BMPs within four basic categories: water management practices, nutrient management practices, control of sediment and particulate matter, and pasture management (where applicable). Points for each BMP are assigned based on effectiveness as determined by research, and, in some cases, professional judgment. A list of BMPs and points are provided by Gomez and Bedregal (2009), who note that while

TABLE 5-1 Estimated Phosphorus Loads by Land Use in Three South Florida Watersheds

	Phosphorus Load (pounds/acre/year)		
	St Lucie	Caloosahatchee	Lake Okeechobee
Row crops	4.50	3.45	6.3
Field crops	2.96	4.09	No data
Tree nurseries	2.90	4.00	No data
Sod	2.52	2.79	2.52
Citrus	1.80	0.90	1.62
Improved pastures	1.90	1.93	0.72
Unimproved pastures	0.92	0.99	0.27
Woodland pastures	0.88	0.83	0.27
Sugar cane	0.63	0.55	0.63
Rangeland	0.28	0.25	0.23
Residential-medium density	1.40	1.93	0.37

SOURCES: SWET, Inc. (2008); Bottcher (2003).

“permits at a minimum BMP point level of 25 proved effective in the EAA, more comprehensive BMP plans and supplemental projects to develop the technical information for a more effective program are necessary in the C-139 basin (35-point level).” The development of a BMP plan for a particular farm or parcel should consider a balance of BMPs that address both flow and phosphorus concentration with the total points adding up to at least a minimum required level. There is some indication that the lack of balance among the BMPs may be partially responsible for the poor performance in the C-139 basin (P. Wade, SFWMD, personal communication, 2010). From the beginning, comprehensive BMPs including water management, nutrient control, and sediment control were applied in the EAA, but this was not the case in the C-139 basin, where, in many cases, establishment of water retention facilities was sufficient to satisfy the 35-point requirement for BMPs.

The current method of using a points system to quantify the expected impact of a suite of BMPs assumes that the cumulative effect of the BMPs is additive, and that each practice is equally effective on different soils and landscapes. It is unlikely that either of these assumptions is valid. An alternative approach is to apply simulation models that have been developed for both field and watershed scales to describe the hydrology and water quality impacts of management practices and land uses. Once the model is set up and calibrated for a given basin (a one-time process), it could be used to assess the impacts of many combinations of BMPs and land uses on phosphorus loads, or other objective functions. There are several models that have been developed and tested for conditions in the Everglades watersheds that could potentially be used for this purpose, including the Watershed Assessment Model (WAM; Bottcher et al., 1998), which has recently been set up for use in the C-139 basin. Wider application of this technology would lead to improved understanding of the hydrology of the system and of the effect of practices and land uses on the movement and fate of phosphorus and other constituents.

Data in Appendix 4-2 of the 2010 SFER (Pescatore and Han, 2010) show permit-level phosphorus concentrations and loads in the EAA. The maps and tables show that although many farms in the EAA are achieving substantial reductions in phosphorus loads (with some reductions >90 percent compared to baseline), the reductions are not consistent across the basin. Some plots are generating much higher loads compared to other plots and to baseline data, with loads of up to 13 pounds/acre and reported farm-level TP concentrations of up to 1,000 ppb. Given this information, it seems that there is room for improvement in source control, even within the high-performing EAA.

As noted in Chapter 3, despite the current acreage of STAs and the extensive BMP initiatives, there has been a water quality “exceedance” in WCA-1, which is considered a violation of the Consent Decree. The current regulatory

structure, however, limits just how much further the SFWMD can go to improve source control efforts in the EAA, which is already meeting its state-mandated reductions, without additional rulemaking. The SFWMD is working closely with farmers in the underperforming C-139 basin to try to improve source control efforts in that area. The committee did not have the data needed to analyze how much additional phosphorus could be removed by agricultural BMPs and at what costs, but this information is critical to long-term comprehensive systemwide phosphorus management decisions. Ultimately, such decisions need to be informed by a strong monitoring, research, and modeling program that focuses on improving our understanding of phosphorus sources and loads; the effectiveness of current and new BMPs, both separately and in sequence; and the costs and benefits of additional remedial measures.

Costs of Enhanced BMPs South of Lake Okeechobee. To the committee's knowledge no cost-effectiveness analyses of source controls in the EAA or of other agricultural lands in the South Florida ecosystem have been published. Further reduction in phosphorus loads within the EAA or C-139 basin may require practices that reduce crop yield and profit. If this is the case, an incentive could be offered to entice farmers to adopt the more aggressive control practices, assuming that the cost of the incentive is less than the costs of other comparable phosphorus control and treatment strategies. The incentive would allow farmers to increase their income, despite reduced crop yields and profits. Evaluation of the economically optimal incentive would require knowledge of production-function relationships between farming practices (e.g., fertilizer use, water management approaches), phosphorus losses to drainage waters, and crop yields. Some of these relationships are known and available; others would have to be determined through focused research efforts.

An extreme option is to remove land from production, close field ditches, and substantially decrease phosphorus losses from those fields. This alternative would only be attractive to a land owner/operator if the incentive payment is greater than the profit from continuing crop production. However, based on the specific land parcels, the cost to the SFWMD may still be less than the cost of constructing additional STAs to treat the drainage water. One situation for which this approach may be particularly attractive is in areas of the EAA where soils have subsided such that the organic layer depth is less than 12 inches thick. Production of sugar cane is generally not considered profitable on such soils, and lands that are converted to sod production, vegetable crops, or suburban development often result in higher phosphorus loading rates to the environment (see Table 3-1). A cost-effectiveness analysis could assess whether a program to remove these lands from production and prevent future detrimental land use conversions would be less expensive than the treatment alternatives. However,

any program that removes land from production also needs to consider the associated economic and social costs including jobs and tax revenues.

Phosphorus Control Measures Within Lake Okeechobee

Approximately 30,000 mt of phosphorus exist in the upper 10 cm of the mud sediments in Lake Okeechobee (Fisher et al., 2001). These sediments create an internally generated phosphorus load through diffusion into the water column and re-suspension of the sediments during wind events. One approach to reduce phosphorus loads in the South Florida ecosystem is to manage the phosphorus released from sediment within the lake. Only limited phosphorus management actions have been taken to date within the lake. During the drought of 2006-2007, the SFWMD removed approximately 1,300 acre-feet (or 1.6 million cubic meters) of mud sediments along exposed shorelines in Lake Okeechobee (SFWMD and FDEP, 2008a). This large volume represents less than 1 percent of the 162,142 acre-feet of mud sediments estimated in the lake (Engstrom et al., 2006).

The SFWMD conducted a feasibility study of alternatives to evaluate improvements in water quality by managing phosphorus released from lake sediments (SFWMD, 2003). The study considered approximately 30 possible actions, and ultimately, three options were evaluated in detail with respect to cost, effectiveness, and timeliness: (1) hydraulic dredging, (2) in-place chemical precipitation with aluminum compounds, and (3) no in-lake action. Removing 12 inches of sediments from the lake via hydraulic dredging would remove an amount of phosphorus equivalent to the rate of accumulation over 94 years, but it was estimated to take over 15 years to accomplish this task (SFWMD, 2003). Despite these high costs, the dredging would leave behind a significant amount of phosphorus-enriched sediment, which would continue to release phosphorus into the water column for several decades. Dredging also would not reverse eutrophication unless the external phosphorus loads were also curtailed (Kleeberg and Kohl, 1999).

SFWMD (2003) also considered applications of chemicals, including aluminum sulfate (“alum”) and sodium aluminate, to reduce dissolved and suspended phosphorus concentrations. Application of calcium-based chemical amendments can also potentially reduce the turbidity of lake water, which can cause enhanced dissolution of phosphorus. In-lake treatments to control phosphorus have been used successfully elsewhere on a smaller scale (Cooke et al., 1993; Welch and Cooke, 1999). The SFWMD predicted that aluminum compounds could inactivate existing phosphorus and much of the new phosphorus added to sediments for approximately 15 years. However, unless additional source controls are implemented to reduce phosphorus loads to the lake, the lake would

progressively return to the original contaminated state, because the surface of aluminum oxy-hydroxides would become fouled and buried with sediments over time. Addition of chemical amendments to large lakes such as Lake Okeechobee has not been evaluated. To be effective, applied chemical amendments must be in direct contact with sediments, and considering the size of Lake Okeechobee, this would be difficult to achieve. The potential ecological effects of chemical amendments in Lake Okeechobee also have not been fully evaluated.

These actions were contrasted against a “no in-lake action” alternative, which was ultimately selected by the SFWMD. If the TMDL could be met by 2015, the SFWMD estimated that the algal bloom frequency would be reduced to less than 15 percent by 2015 and less than 10 percent by 2028. However, NRC (2008) concluded that given the current management actions and the no in-lake actions, it will likely take decades to reach the TMDL, further contributing to the water quality problems in downstream locations. Given the magnitude of the phosphorus challenges, the SFWMD should reconsider the costs and benefits of in-lake actions, perhaps combined with aggressive source control strategies in the Lake Okeechobee watershed.

Costs of In-lake Treatment

In a 2003 study of options for phosphorus treatment in Lake Okeechobee, the SFWMD provided detailed cost estimates for two approaches: hydraulic dredging and in-place chemical precipitation with aluminum compounds. Removal of the upper 12 inches of mud sediment across the lake via hydraulic dredging was estimated to cost \$3 billion (in 2002 dollars), even though it would leave a significant amount of phosphorus-enriched sediment in place. Inactivation of phosphorus in the lake by chemical precipitation was estimated to cost \$500 million (in 2002 dollars) (SFWMD, 2003). These costs analyses were conducted to examine alternatives for meeting the TMDL in Lake Okeechobee and were not part of a broader systemwide analysis of nutrient management. Any future analysis of in-lake water quality remediation efforts would also need to consider any associated ecological consequences of such actions.

Progress in Phosphorus Load/Concentration Reduction Due to STAs

Constructed wetlands, also known as stormwater treatment areas (STAs), are used throughout the country to retain nutrients and other contaminants by using microbial and vegetation communities to create refractory residuals. Nutrients from the water column are retained by vegetation and particulate matter that typically accretes as floc on the soil surface. Long-term monitoring data of constructed wetlands in the United States demonstrate that they are most efficient

in removing inorganic forms of phosphorus and nitrogen and less efficient in removing organic forms of phosphorus and nitrogen (Kadlec and Wallace, 2009). The extent of management required depends upon the nutrient and contaminant retention capacity of the wetlands and the desired effluent quality.

Overview of Everglades STAs

Phosphorus management through STAs has been a major focus of the SFWMD through the Everglades Construction Project (see Box 2-3) and the district's Long-Term Plan for Achieving Water Quality Goals (Burns and McDonnell, 2003). STAs are key components of the strategy to reduce nutrient loads and achieve long-term water quality goals in the Everglades Protection Area. The SFWMD has constructed about 45,000 acres of STAs on former agricultural lands at six strategic locations to reduce nutrient loads entering the WCAs (Figures 5-6 and 5-7). These STAs are large units of land, ranging from 870 to 16,543 acres of effective area arrayed around the southern boundary of the Everglades Agricultural Area. Another 12,000 acres of treatment wetlands (Compartments B and C, adjacent to STA-2 and between STAs -5 and -6, respectively) are under construction and are scheduled to be flow-capable in 2010 (SFWMD, 2010a). More than 35,000 acres of additional STAs are planned for the CERP (USACE and SFWMD, 1999) in locations north of Lake Okeechobee, in the Caloosahatchee Basin, in the Upper East Coast Area, along the eastern edge of the Everglades Protection Area, and in the North Palm Beach County area.

The SFWMD's STAs are large treatment systems originally designed to operate as passive systems with minimal management. Each STA consists of several cells, operated in series and/or in parallel, through which nutrient-rich water (typically from the EAA and Lake Okeechobee and from other sources such as the C-139 and C-51 basin [see Figure 5-3]) flows and nutrients are removed, before being discharged into the ecosystem. Cells are constructed such that inflow and outflow rates are controlled, and the plant community within each cell is managed. An extensive monitoring and research program is in place to support the management of these treatment areas. The SFWMD is responsible for operating, maintaining, and optimizing the nutrient removal performance of STAs constructed as part of the Everglades Construction Project or the Long-Term Plan.

The first STA (precursor to STA-1W) in the Everglades was completed in 1994 as an experimental unit. The Everglades Construction Project STAs that are now in operation include: STA-1E (since 2004) and STA-1W (since 1994), STA-2 (since 2000), STA-3/4 (since 2004), STA-5 (since 1999), and STA-6 (since 1998). Between WY 1994 and WY 2009, these six STAs retained approximately 1,210 mt of phosphorus, representing a total load reduction of 72 percent of

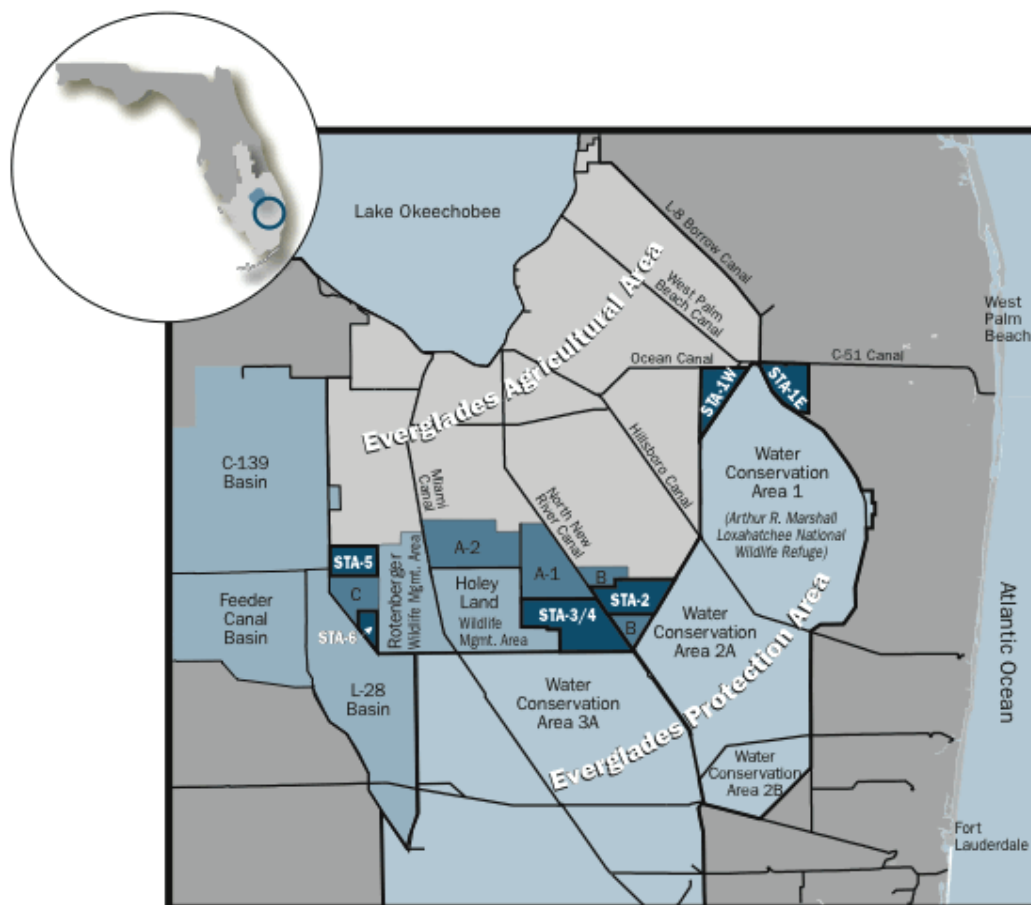

FIGURE 5-6 Location of the six Everglades stormwater treatment areas (STAs): STA-1E, STA-1W, STA-2, STA-3/4, STA-5, and STA-6).

SOURCE: https://my.sfwmd.gov/portal/page/portal/common/newsr/sta_map_8_2008.gif.

inflow phosphorus. Hurricanes severely impacted the STAs during WY 2005 and WY 2006 with large volumes of inflows and phosphorus loads. Heavy wind events also damaged some of the most sensitive portions (cells with submerged aquatic vegetation) of the STAs. Following these years, South Florida experienced drought for three consecutive years (WY 2007, WY 2008, and WY 2009), resulting in a reduction of flows and phosphorus loads, although not necessarily a reduction in outflow TP concentrations (Pietro et al., 2010).

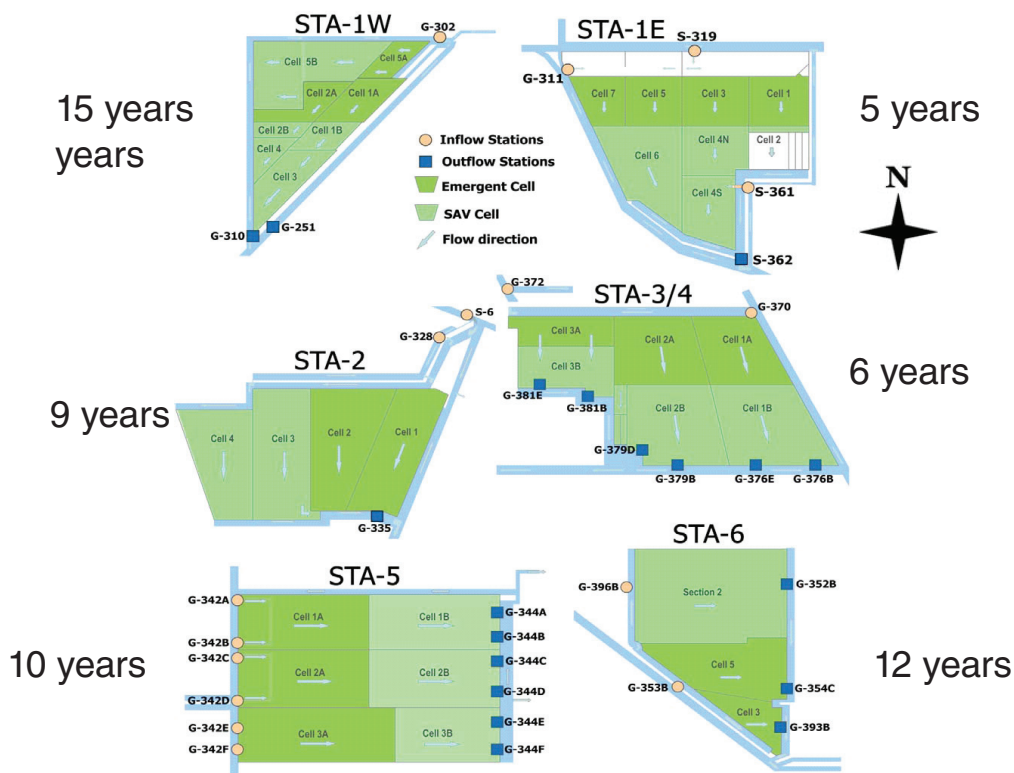

FIGURE 5-7 Schematics of the STAs showing orientation of the treatment cells and locations of the permitted inflow and outflow stations. Age of the STA is up to the year of WY 2009.

SOURCE: Pietro et al. (2010).

During WY 2009, the six STAs retained an average of 82 percent of the inflow phosphorus load (Table 5-2). The STAs retained 180 mt of phosphorus and reduced inflow flow-weighted mean TP concentration from 152 ppb to 25 ppb. Phosphorus removal efficiency in the six STAs in WY 2009 ranged from 64 to 88 percent, with STA-6 recording the lowest efficiency. During WY 2009, the STA system was in compliance with all operating permits. Phosphorus loading rates for WY 2009 (1.4 g/m²/year) were within the design criteria established for STAs,¹² although STA-2 and STA-3/4 were loaded at much lower rates than

¹²The design criteria listed by Burns and McDonnell (1994) and Walker (1995) assumed steady-

TABLE 5-2 Stormwater Treatment Area (STA) Performance During WY 2009

STAs	Average Inflow TP ppb	Average Outflow TP ppb	Average TP Inflow Load g/m ² /year	Average TP Outflow Load g/m ² /year	Average TP Retained Load g/m ² /year	Average % TP Removal Efficiency
STA-1E	182	21	1.61	0.19	1.42	88
STA-1W	246	36	1.85	0.30	1.55	84
STA-2	122	18	1.13	0.20	0.93	83
STA-3/4	96	13	0.78	0.11	0.67	86
STA-5	254	56	1.71	0.40	1.31	77
STA-6	198	94	1.53	0.55	0.98	64
All STAs ^a	152	25	1.39	0.36	1.03	82

^aThe results presented for "All STAs" reflect an average of all annual data available for the STAs, thereby accounting for the fact that some STAs have been in operation for much longer than others.

SOURCE: Pietro et al. (2010).

the average design loading rate (Pietro et al., 2010). Because of the drought conditions, the performance evaluation of STAs during WY 2009 alone cannot be viewed as typical of sustained performance.

In addition to STAs in the EAA, two STAs have been recently constructed in "nutrient hotspots" in the Lake Okeechobee watershed: the Taylor Creek STA (142 acres effective area) and the Nubbin Slough STA (773 acres effective area). Both STAs are fully Constructed, and the Taylor Creek STA has passed preliminary performance tests, but neither STA is fully operational.

Long-Term Performance of STAs

The performance of STAs is influenced by several factors including (1) antecedent land use, (2) nutrient and hydraulic loading, (3) vegetation composition and condition, (4) soil type, (5) cell topography, (6) cell size and shape, (7) extreme weather conditions, (8) construction activities to improve performance (enhancement activities), and (9) regional operations (Pietro et al., 2010). Overall during the period of record, STAs have experienced variable loadings, extreme weather conditions, and internal management of vegetation.

Considerable data exist on water quality to evaluate long-term performance of STAs (Table 5-3). During the period of operation, phosphorus loading was highly variable among the STAs, and average inflow TP concentrations ranged from 92 to 229 ppb. The large standard deviations in the loading rates reflect

state performance of the STAs, with a design loading rate of 1.4 g/m² year and a target outflow of 50 ppb. The STAs design criteria did not consider the temporal characteristics of inflows and extreme weather conditions. The design assumed a 36-year lifespan of the STAs with only passive management.

TABLE 5-3 STA Performance During the Period of Record (WY 1994-WY 2009)

STAs	Period of Record Years	Inflow TP ppb	Outflow TP ppb	TP Inflow Load g/m ² /year	TP Outflow Load g/m ² /year	TP Retained Load g/m ² /year	% TP Removal Efficiency
STA-1E ^a	4	150±34	64±59	0.99±0.5	0.34±0.17	0.65±0.66	51±40
STA-1W	15	164±57	48±34	1.94±1.22	0.63±0.61	1.31±0.66	72±12
STA-2	9	107±31	21±8	1.31±0.46	0.34±0.22	0.97±0.36	75±10
STA-3/4	6	108±34	18±5	1.03±0.69	0.16±0.13	0.88±0.57	85±3
STA-5	10	229±55	110±42	1.93±1.36	0.77±0.59	1.28±0.79	54±22
STA-6	12	92±42	29±22	1.19±0.50	0.23±0.13	0.95±0.42	80±7

^aFirst-year operational data were not included.

SOURCE: Data from K. Pietro, SFWMD, personal communication, 2010.

the effects of droughts and extreme wet periods. The SFWMD tries to keep the loading rates as consistent as possible, but with the limited storage available, extremely wet periods have caused inflow loads to exceed design loads at some point in all STAs. STAs -2, -3/4, and -6 typically received water with lower inflow TP concentrations compared to STAs -1E, -1W, and -5, reflecting land-use differences in the areas of the EAA that generated the runoff. The three STAs with the highest inflow concentrations (STAs -1E, -1W, and -5) also had the highest mean TP outflow concentrations. During the period of record, STA-1W and STA-5 exhibited high outflow TP concentrations of 48 and 110 ppb, respectively. Other STAs produced outflow TP concentrations of <30 ppb (see Table 5-3). Given current performance of the STAs, the original design assumptions with respect to loading rates and passive management may not be adequate, and refinement of the operational strategies is needed to optimize the phosphorus removal efficiency of the STAs.

Data for STA-1W, which has been in operation for 15 years, may be useful in refining long-term STA management strategies. During the first 10 years of operation (until WY 2004), inflow TP concentrations of STA-1W were consistently <150 ppb, while outflow concentrations were in the range of 25 to 50 ppb (Figure 5-8a). Phosphorus loading rates during the first 10 years of operation ranged from 1 to 1.5 g/m²/year, but extreme weather conditions (i.e., hurricanes and drought) from WY 2005 to WY 2007 resulted in substantially increased phosphorus loading in the range of 2 to 4.5 g/m²/year (Figure 5-8b). This resulted in decreased treatment efficiency and elevated levels of outflow TP levels. The key management lessons and research needs that are highlighted these long-term data sets are described in the sections that follow.

Managing Inflow Loads. The relationship between TP inflow and outflow loads

(a)

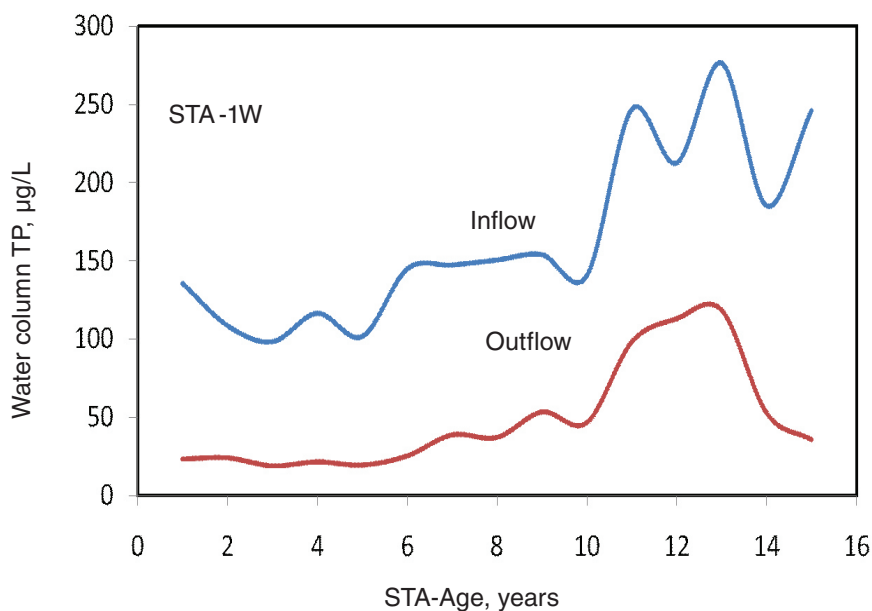

(b)

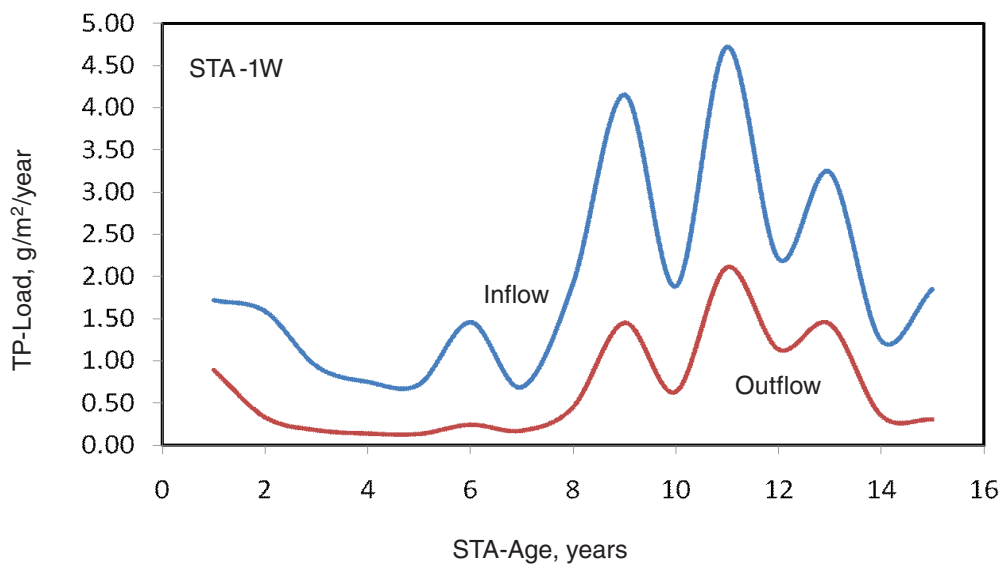

FIGURE 5-8 Flow-weighted mean TP (a) concentrations and (b) loads for inflow and outflow of STA-1W during period of record.

SOURCE: Data from K. Pietro, SFWMD, personal communication, 2010.

suggests an approximately 60 percent reduction in inflow load among all the STAs (Figure 5-9). However, the efficiency of individual STAs ranged from 51 to 85 percent (Table 5-3). With the exception of STA-5 and STA-1E, and STA-6 for a few years, most of the STAs produced outflow TP concentrations of 50 ppb or less at TP loading rates of <2 g/m²/year (Figure 5-10). In fact, the bulk of the data with <2 g/m²/year loading appears to show outflow TP concentrations in the range of 20-25 ppb. The long-term data also indicate that much higher concentrations (>50 ppb) are routinely observed at inflow phosphorus loads above 2 g/m²/year. Figure 5-8 shows an example of extreme loading across multiple years in STA-1W (including two hurricane years) and the impact on TP outflow concentrations, which ultimately exceeded 100 ppb as an annual mean. Although reduced inflow loads do not guarantee low outflow concentrations, reduced loading is clearly an important component of STA management, albeit challenging in the variable climate conditions of South Florida (see Box 2-2).

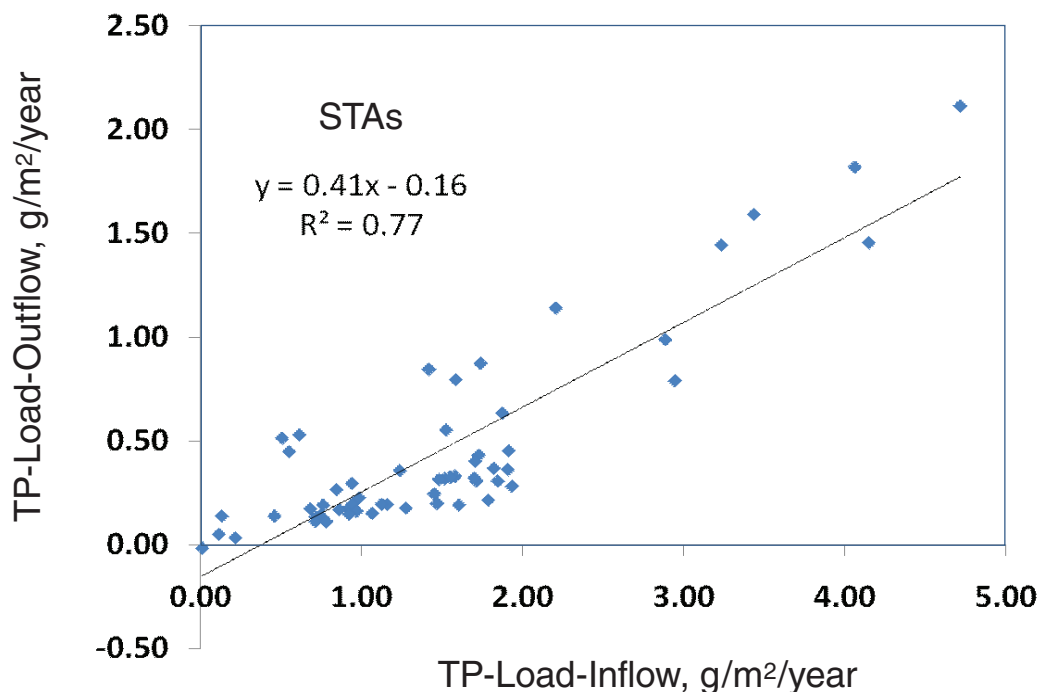

FIGURE 5-9 Relationship between TP inflow load and outflow load of STAs during period of record.

SOURCE: Data from K. Pietro, SFWMD, personal communication, 2010.

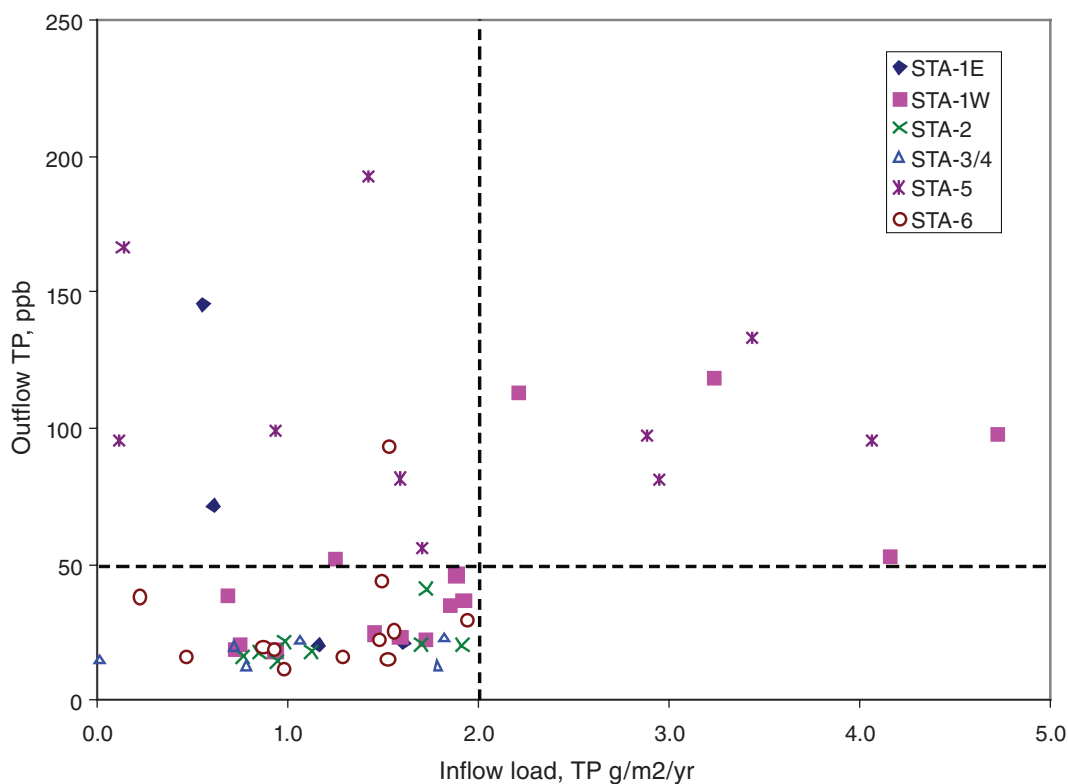

FIGURE 5-10 Relationship between TP inflow load and outflow water column TP concentration of STAs during period of record. Plotted values are mean annual flow-weighted concentrations and mean annual phosphorus loads for each of the STAs over the period of record.

SOURCE: Data from K. Pietro, SFWMD, personal communication, 2010.

Effect of Other Water Quality Parameters. The process of phosphorus retention in wetland systems is coupled to other nutrients that affect vegetation growth and microbial activity and chemical reactions that determine phosphorus availability and cycling. Thus, phosphorus removal and stability of the stored phosphorus in STAs is regulated by inflow water chemistry, including nitrogen, sulfur, calcium, and magnesium, and transformations of these chemicals within the STAs. The concentrations of calcium and other inorganic chemicals should be monitored as part of routine performance assessments. See the additional descriptions of the role of calcium in the phosphorus cycle in the section on conductivity later in this chapter.

Vegetation Management. Emergent and submerged vegetation promote phosphorus removal in wetlands by (1) sequestering phosphorus in biomass, which is retained as peat in the system; (2) altering water chemistry and promoting chemical precipitation of phosphorus; and (3) providing a source of carbon and energy for the microorganisms that support biogeochemical cycling of phosphorus (Noe et al., 2001; Reddy et al., 2005). Thus, vegetation management is critical for achieving the desired treatment goals of STAs, but several challenges have been encountered. For example, floating aquatic plant mats commonly form in STAs and may cause lower nutrient assimilative capacity and increased flux of nutrients from sediments to the water column. Also, submerged aquatic vegetation (SAV) communities have proven to be sensitive to change in water depth, inflow water chemistry, and soil characteristics. Deeper water depths may create problems for emergent aquatic vegetation cells. STA managers could possibly reduce these problems by developing other management strategies including mixed plant communities (SAV and emergent aquatic vegetation) within the same treatment cell.

Vegetation management is directly linked to sediment management in STAs. Recently, when accreted soil in some SAV cells was found to be unstable, rice was planted to stabilize these soils and improve the STA performance. Optimization of vegetation management is especially critical in older STAs because they tend to accumulate more unstable sediments, which provide a poor anchor for plant roots.

Newly Accreted Soil Management. Water column phosphorus is retained by particulate matter that typically accretes as floc on soil surface. Floc is defined as unconsolidated material consisting of undistinguishable detrital matter, plankton biomass, and other suspended particulate matter. Floc plays a critical role in dictating long-term performance of STAs. Once a STA starts accreting organic matter and other particulate matter, the newly accreted material dictates the exchange of phosphorus between soil and the water column. Across the various STAs, the proportion of phosphorus stored in floc and soil (0-10 cm depth) increased (ranging from 14 to 64 percent) as the age of the STA increased (see Figure 5-11). Phosphorus enrichment in the floc and surface soil decreases the potential phosphorus uptake from the overlying water column. This has been shown in WCA-2a (Richardson and Vaithyanathan, 1995; Clark, 2002).

STAs are, therefore, not self-sustaining systems, and they require significant management over time to meet the outflow TP criteria. Soil management to increase the long-term sustainability of the STAs could include one or more of the following strategies: (1) periodic dredging and removal of phosphorus-laden sediments, (2) growing rice to stabilize the soils, (3) adding chemicals to consolidate the floc, and (4) preventing soil oxidation associated with periodic

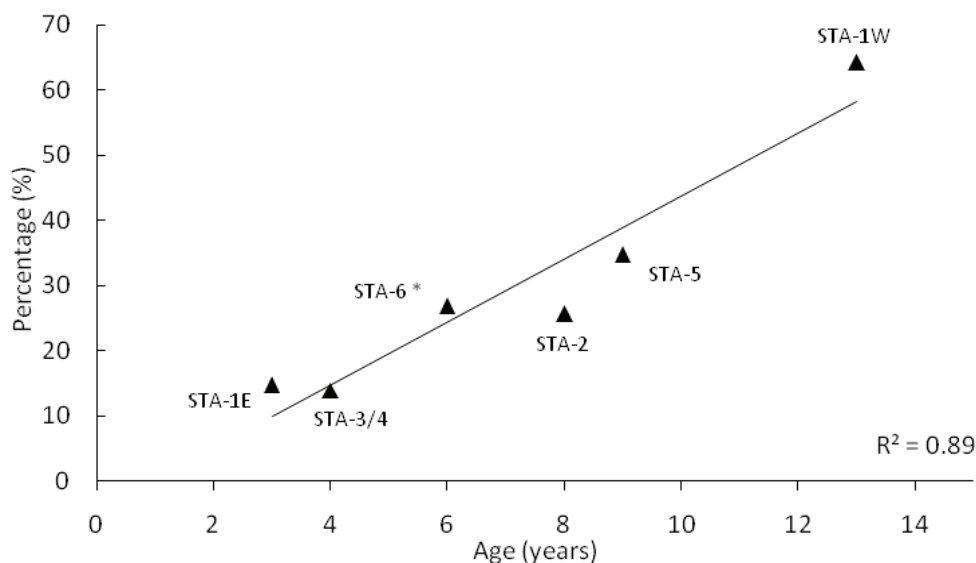

FIGURE 5-11 Percentage of total (floc + 0-10 cm soil) phosphorus storage derived from water column phosphorus removed. All STAs depict WY 2007 data except STA-6, which indicates WY 2004.

SOURCE: WBL (2009).

draw-downs. During WY 2007, the SFWMD conducted major rehabilitation activities in STA-1W, including dredging and sediment removal and planting rice. After these treatments, STA-1W showed significant improvements in outflow TP concentrations and phosphorus retention (Figure 5-8).

Implications for Downgradient Water Quality

The prior discussion highlights the challenges in approaching target TP discharge concentrations (i.e., 17 ppb TP at the STA discharge point was calculated for STA-3/4 to be consistent with the 10 ppb TP criterion [see Walker, 2005, and Payne et al., 2010a]) without the addition of substantially more acreage to the STAs, more vigilant maintenance of accreted sediments, and careful control of inflow phosphorus loads. Given the recent confirmed exceedance of the Consent Decree (see Chapter 3), it is clear that the current acreage of the STAs with their current loading is insufficient to meet the phosphorus criterion. Although an additional 12,000 acres of STAs is under construction, Compartments B and C are not located at the right locations to address this exceedance. With increased

volumes of water planned for the CERP, substantially more water quality treatment and/or additional load reductions will be needed if the new flows are to meet the water quality criteria. For the CERP alone, it has been estimated that 54,000 acres of additional STAs—beyond those constructed or planned (such as Compartments B and C)—will be needed to treat CERP flows to achieve a maximum annual flow-weighted mean concentration of 17 ppb TP (the water quality-based effluent limit (WQBEL) for STA-3/4; W. Walker, consultant, personal communication, 2009).¹³ If lower concentrations are required or different interpretations of the WQBEL are applied, even larger acreage or more source controls would be needed.¹⁴ The cost implications of these findings are discussed later in the chapter.

Long-term sampling has also demonstrated that even among the best-performing STAs there are gradients of elevated phosphorus within the lands receiving STA water. In WCA-1, the Arthur R. Marshall Loxahatchee National Wildlife Refuge, elevated concentrations are observed within the first 0.6 miles (1 km) of the inflows from both STA-1E and STA-1W. Within WCA-2A, discharges from STA-2 display gradients of elevated (up to 40 ppb) TP over distances of up to 2.2 miles (3.5 km; Scheidt and Kalla, 2007; Figure 5-12). Consideration of the ecological impacts of these gradients and their rate of change is important to understanding the adequacy of existing treatment and discharge approaches.

Research and Monitoring Needs to Support Long-Term STA Sustainability

Understanding the factors and processes that control long-term performance is essential to optimizing the efficiency and the long-term sustainability of STAs. Focused research efforts directed at improving STA management and

¹³For this analysis, CERP flows were assumed to be 1.86 MAF/year to the Everglades Protection Area, compared to current flows of 1.38 MAF/year.

¹⁴After the committee's report was largely completed, the U.S. EPA released its Amended Determination on September 3, 2010. The committee was not able to review the Amended Determination for the purposes of this report. However, for the purpose of comparing the acreage reported in the Amended Determination with the acreage reported here, brief summary of the EPA findings is provided. EPA stated that 42,000 acres of additional STAs would be needed to meet a two-part Water Quality Based Effluent Limit (WQBEL), which provides that TP concentrations in STA discharge may not exceed *either* (1) 10 ppb as an annual geometric mean in more than two consecutive years, or (2) 18 ppb as an annual flow-weighted mean. EPA calculated the WQBEL to assure that STA discharges would not cause an exceedance of the long-term criterion of 10 ppb. The EPA Amended Determination did not forecast the acreage of STAs that would be necessary to support CERP flows while meeting the 10 ppb criterion. Using earlier governing assumptions, Walker (consultant, personal communication, 2009) calculated that 25,000 acres would be needed to treat current flows to achieve a maximum annual flow-weighted mean concentration of 17 ppb TP. Thus, the acreage estimated above for STA requirements to meet CERP flows (54,000 acres) would be substantially larger if calculated using more recent assumptions based on EPA's two-part WQBEL.

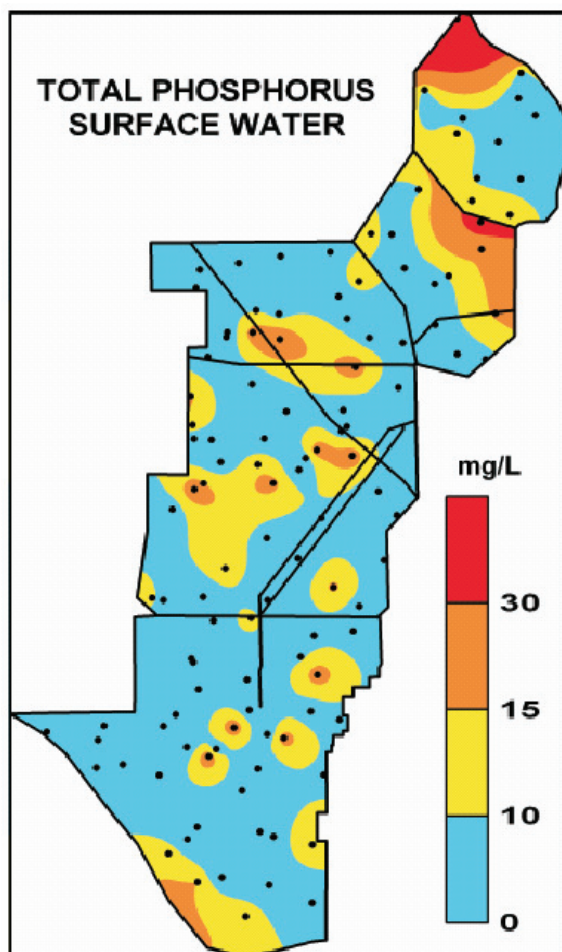

FIGURE 5-12 Total phosphorus concentration in surface water during November 2005.

SOURCE: Scheidt and Kalla (2007).

design have examined the effectiveness of different kinds of vegetation for phosphorus removal (Ecological Engineering, 2006; White et al., 2006; Gu and Dreschel, 2008), differences between STA cells built on historical wetlands and on previously farmed soils (Juston and DeBusk, 2006), and the efficacy of STA systems at low loading rates (Juston and DeBusk, 2006; Gu and Dreschel, 2008). The SFWMD has also sponsored research to optimize STA performance under extreme climatic conditions, including high water and winds or drought, and

to develop adaptive protocols for responding to such conditions. Indeed, performance of the STAs during WY 2009 showed considerably improved success over WY 2007 in managing water levels to avoid damage to aquatic vegetation, demonstrating the importance of management decisions and the potential for adaptive management to improve STA performance.

An extensive water quality monitoring program is also in place, and a new soil monitoring program was recently initiated to document the details of STA function and to determine the aspects of long-term sustainability. Soils provide a long-term record of nutrient accumulation and thus serve as an excellent indicator of system performance. A more consistent soil monitoring program is needed, especially with respect to sampling similar soil depths and analyzing the soils for macronutrients (e.g., carbon, nitrogen, phosphorus, sulfur, organic matter) and physical properties (e.g., bulk density). There is also a need to establish a uniform and robust soils reference data set, which would serve as a benchmark for the comparison of outcomes of various subsequent interventions. Additional studies are needed to determine the stability of phosphorus stored in the soils and how phosphorus retention capacities change with the STA's period of operation.

The monitoring program is commendable, but it needs to be supported by a systematic research program that evaluates the overall STA system and includes cross-STA comparisons and consideration of the effects of the age of STA operations on performance and long-term sustainability. In particular, research is needed to assess the long-term ability of STA units to sustain or improve upon their current level of functioning. The committee also identified several areas where additional research might lead to improved STA operation and phosphorus removal efficiency:

- Determine the stability of phosphorus stored in floc and soils and determine how phosphorus-retention capacities change with period of operation of the STA, flow rates, climatic conditions, and altered water chemistry;
- Determine the inter-relationships between phosphorus and other elemental cycles (e.g., nitrogen, calcium, sulfur) and their effects on vegetation and phosphorus removal efficiency;
 - Improve strategies for managing the system during climatic extremes (e.g., droughts, hurricanes), particularly from the point of view of the entire hydrologic system (i.e., how will flow restrictions during high water or flow requirements during droughts affect water flows and water levels upgradient and downgradient from the STAs?);
 - Determine the long-term effects of accreting sediments on hydrology and vegetation and the variables that affect the frequency with which extensive soil management (i.e., dredging and removal of nutrient-laden sediments) will be needed;

- Analyze how STA vegetation communities respond to environmental changes and STA management;
- Identify the factors that contribute to the formation of floating aquatic plant mats, determine their effects on phosphorus removal efficiency, and if justified, develop strategies to reduce their formation; and
- Integrate the current knowledge of phosphorus retention and release processes in STAs into management tools such as DMSTA, which can assist in forecasting STA performance and planning management activities.

Useful improvements could also be realized by an external peer review of the STA monitoring and research program, including the design criteria and modeling efforts.

STA Costs

The capital costs for STAs have been broadly estimated at \$20,000/acre, consisting of \$6,000/acre for land acquisition and \$14,000/acre for engineering design and construction. Operating costs include operation and maintenance (O&M) and monitoring costs. Estimates of annual costs for O&M range from \$350 to \$450 per acre and for monitoring from \$50 to \$100 per acre, for a total ranging from \$400 to \$550 per acre (T. Piccone, SFWMD, personal communication, 2009).

It is not known how long the STAs will continue to function effectively without refurbishment or exactly how often or how expensive refurbishment might be. The SFWMD anticipates that major routine rehabilitation/refurbishment will likely be needed after 20 to 25 years of operation to remove accrued sediments and maintain the hydraulic capacity of the STAs. It also anticipates that minor rehabilitation might be needed on a more frequent basis if there is major damage from hurricanes or other major storm events. SFWMD scientists are collecting data on accretion rates, and although a great deal of uncertainty remains, they have estimated accruals of 8-12 inches of material over 20-25 years of operation (T. Piccone, SFWMD, personal communication, 2010). Applying the cost per cubic yard of sediment removed to this estimate, the SFWMD calculated that the cost to remove the sediment would be \$16,800–\$21,400 per acre (2010 dollars).

Assuming a 50-year effective life and refurbishment every 20-25 years, and using a 2.7 percent discount rate, the committee calculated a total present value cost of \$39,539 to \$54,692 per acre (2010 dollars). The lower bound estimate assumes refurbishment after 25 years and uses the low-end estimates of annual O&M, monitoring, and refurbishment costs. The upper bound is a “worst case” that assumes refurbishment after 20 years and again after 40 years, and uses the high-end estimates of annual O&M, monitoring, and refurbishment costs. Using

the average values for O&M, monitoring, and refurbishment costs and assuming refurbishment after 25 years, the total present value cost is \$42,766 per acre.

Using the Dynamic Model for Stormwater Treatment Areas (DMSTA), the SFWMD has estimated that the 56,500 acres of effective treatment areas in the existing STAs (including Compartments B and C, under construction) will remove approximately 10,100 mt (or 393 pounds per acre) of phosphorus over a 50-year period. Using average values for O&M, monitoring, and refurbishment costs and assuming refurbishment after 25 years, the total present value cost per pound of phosphorus removed is \$109. The amount of phosphorus removed by the STAs is a key parameter affecting the present value calculation, and considerable uncertainty remains regarding this value. For every 10 percent increase in phosphorus removed, the present value cost will decrease by 10 percent, or approximately \$10 to \$14 per pound. Conversely, if the actual phosphorus removal is 10 percent less than currently estimated, the present value cost will increase by 10 percent, or approximately \$10 to \$14 dollars per pound.

Costs of this magnitude create important ongoing cash-flow considerations for SFWMD restoration planning. The annual average O&M and monitoring costs for the 56,500 acres of existing STAs total \$26.8 million. In addition, the average refurbishment costs are estimated to total approximately \$1.1 billion every 20 to 25 years.

The relatively high cost of phosphorus removal for the STAs and the uncertainty regarding refurbishment intervals and costs and phosphorus removal rates raise two important challenges for further research and analysis. The first is to better understand actual accretion rates, refurbishment intervals, and costs, and the second is to maximize the effectiveness of the STAs for phosphorus removal.

COST-EFFECTIVENESS CONSIDERATIONS

Achieving the CERP objectives of restoration, preservation, and protection of the South Florida ecosystem while providing for the region's other water-related needs is proving to be technically more difficult and costly than originally envisioned. Increasing restoration costs, coupled with constraints on state and federal revenues, highlight the need to assess how to achieve CERP objectives in the most cost-effective manner. This need is particularly acute as it relates to achieving the water quality standards, given the magnitude of the challenges in doing so.

STAs are currently viewed as the primary mechanism for furthering improvement in water quality in the Everglades Protection Area. Given the relatively high construction and O&M costs for STAs and their uncertain life span, the question becomes whether phosphorus could be more cost-effectively removed via other practices. For example, the success of tax incentives for BMPs in the EAA sug-

gests that performance-based incentives (e.g., payment per pound reduction of phosphorus load below a certain threshold, permit-level performance requirements) could be less expensive than building and operating more STAs.

To the committee's knowledge, no systemwide, comprehensive, cost-effectiveness analyses of "getting the water *quality* right" in the South Florida ecosystem have been completed. A wide range of phosphorus control alternatives have been considered, and many have been implemented, including BMPs, wetland restoration projects, in-lake treatments, and STAs, but limited information exists on the relative cost-effectiveness of alternatives beyond those already in place.

The magnitude and spatial scale of the water quality challenges in Florida are daunting and will require massive investments to address. For the CERP alone, it has been estimated that 54,000 acres of additional STAs (beyond that which is already planned¹⁵) will be needed to adequately treat CERP flows (W. Walker, consultant, personal communication, 2009), which would cost roughly \$1.1 billion to construct and \$27 million per year to operate and maintain. Note that this estimate does not address pending regulatory decisions affecting phosphorus and nitrogen in lakes, rivers, canals, and estuaries.

Considering the enormous costs for water treatment that will be needed to meet CERP goals and regulatory requirements, the SFWMD should conduct a comprehensive cost-effectiveness analysis of phosphorus reduction measures to address water quality in the South Florida ecosystem. This analysis should examine all possible options, including novel treatment approaches, enhanced BMPs, land purchases, and regulatory changes, and should evaluate the effectiveness of load reductions (and the related uncertainty) in surface waters in the South Florida ecosystem, particularly the Everglades Protection Area. Ultimately, the solution to the state's water quality challenges will likely require a comprehensive strategy, not a single, most cost-effective solution.

The cost analysis should also examine alternative restoration sequencing and water supply approaches that may be able to address water quality and water quantity concerns in a more efficient manner. For instance, planners should consider whether water quality issues necessitate higher priorities for seepage management projects, which would retain high quality water in the Everglades Protection Area. As noted in Figure 4-2, it is estimated that on average 758,000 acre-feet of water are lost each year from the WCAs via seepage to the east. An additional 220,000 acre-feet are lost via seepage from Everglades National Park. By reducing seepage losses, less new water and, therefore, less water treat-

¹⁵STAs already planned include Compartments B and C. This total does not include recent proposals for additional STAs on the U.S. Sugar lands or to address EPA's amended determination related to water quality standards and treatment expectations in the Everglades Protection Area, announced September 3, 2010. The amended determination was released too late for the committee to review.

ment would be needed. Similarly, different approaches to managing urban and agricultural water supplies might result in the retention of higher quality water in the natural system. According to Figure 4-2, 243,000 acre-feet of water from the WCAs are transferred each year for urban and agricultural water supply. Elevated phosphorus levels are less of a concern for urban and agricultural water uses, and, if feasible, a water management approach that separates ecosystem water storage from urban and agricultural water storage could reduce overall treatment requirements and costs.

The cost-effectiveness analysis should consider multiple timescales for addressing the water quality issues. The committee envisions three timeframes of interest: immediate (3-5 years), mid-term (5-15 years), and long-term (more than 15 years). Water quality measures that would result in immediate improvements tend to be the most management intensive and expensive (e.g., STAs), while mid- and long-term options (e.g., changing land use, widespread enhancement of BMPs) require difficult policy decisions but promise water quality improvements without the extensive long-term O&M costs associated with STAs. Thus, the degree of political support for improving South Florida's water quality and the required timeframes for these improvements will ultimately affect the management decisions and the cost of such measures. However, such decisions cannot be made without a thorough analysis of the alternatives and their associated costs.

Although phosphorus is the overriding contaminant of concern, other contaminants are important to consider in the management of the Everglades ecosystem. Sulfur, mercury, calcium, and conductivity are discussed in the sections that follow. Given the proposed water quality standards, restoration managers will likely give additional emphasis to nitrogen management in the future.

SULFUR, MERCURY, AND PHOSPHORUS INTERACTIONS IN THE EVERGLADES

There are important biogeochemical interactions among sulfur, phosphorus, and mercury that can influence ecosystem functioning, exposure of mercury, and the quality of water in wetlands, including the Everglades. These interactions are largely chemical and microbial in nature and appear to be largely controlled by the supply of sulfur.

Sulfur Sources and Transformations

Sulfur is generally not recognized as a water pollutant, but it has a particularly important role as a contaminant in the Everglades. Sulfur cycles between the more mobile form sulfate (SO_4^{2-}) under oxidizing conditions and sulfide (S^{2-}) under reducing conditions. Concern over sulfur as a contaminant is due to the potential toxicity of elevated concentrations of sulfide and the environmental

effects associated with the processing of sulfate. The EPA water quality standard for sulfide is 2 ppb, which is exceeded in porewaters in areas of the Everglades that receive high inputs of sulfate, including WCA-2A, LNWR, and WCA-3A (Figure 5-13; Scheidt and Kalla, 2007). Concentrations of sulfide are below 0.14 ppm in remote areas of the Everglades that are far removed from canal drainage.

High concentrations of sulfide can be toxic to plants. Li et al. (2009) showed that sawgrass is three times more sensitive than cattail to sulfide concentrations, suggesting that inputs of sulfate to the Everglades could alter the distribution of plant species in favor of cattail. Elevated concentrations of sulfate can enhance the supply of phosphorus from wetland soils to surface waters (Lamars et al., 1998; Smolders et al., 2006), although experiments to date in the Everglades

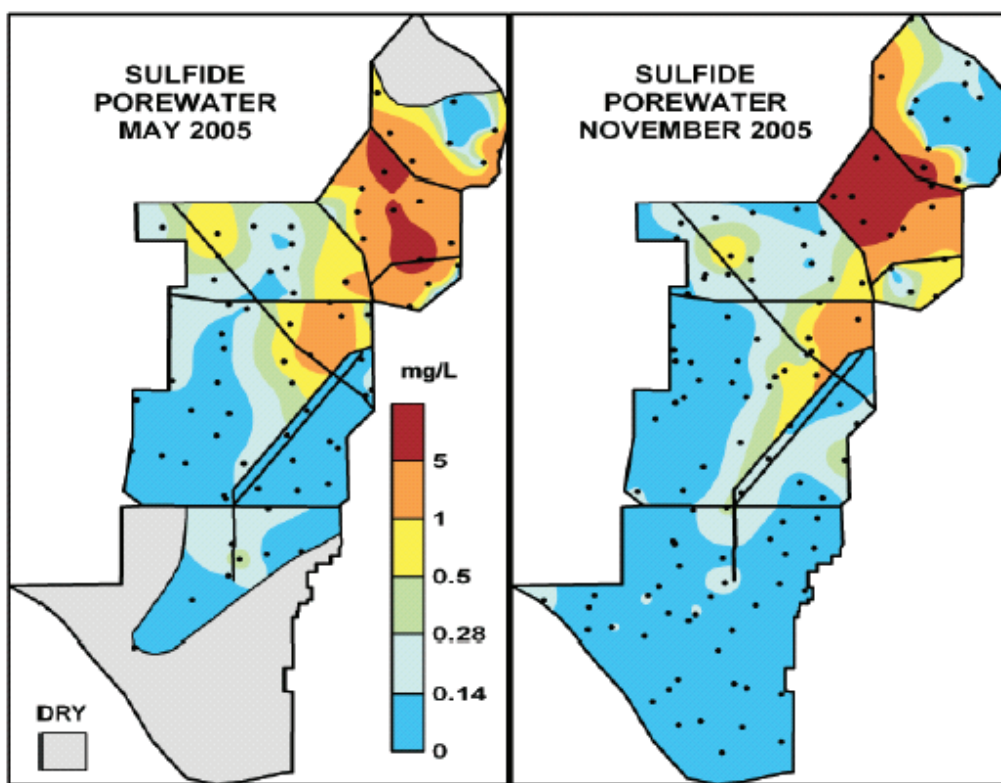

FIGURE 5-13 Concentrations of sulfide in porewaters of the Everglades during May 2005 (left) and November 2005 (right).

SOURCE: Scheidt and Kalla (2007).

have not demonstrated sulfate-enhanced phosphorus release in Everglades soils (DeBusk et al., 2009; Dierberg et al., 2009).

Transformation of ionic mercury (Hg^{2+}) into methyl mercury, the form that bioaccumulates along food chains resulting in elevated exposure to human and other organisms, is largely mediated by sulfate-reducing bacteria (Benoit et al., 2003). Thus, inputs of sulfate will stimulate the production of methyl mercury and can enhance mercury contamination in biota. As a result, the CERP recommends that sulfate concentrations be decreased or maintained to concentrations of 1 ppm or less throughout the Everglades (RECOVER, 2007a). However, the EPA and the state of Florida have not established water quality criteria for sulfate for ecosystem protection.

Historical concentrations of sulfate in the Everglades are thought to be relatively low. Sulfur is applied to EAA soils at rates of approximately 20 to 33 pounds/acre-yr (Wright et al., 2008; Gabriel, 2009) to decrease pH and improve phosphorus availability for agriculture use. Sulfate concentrations vary spatially throughout the Everglades depending on the proximity to the EAA and the relative distribution of water sources from precipitation, stormwater, and groundwater. The highest sulfate concentrations of more than 100 ppm are observed in canals within the EAA and in WCA-2A (Figure 5-14). From this source, concentrations of sulfate in the Everglades decrease toward the south and west, and transport largely occurs via canal discharge. About 60 percent of the Everglades Protection Area currently exceeds background sulfate concentrations of <1 ppm (Scheidt and Kalla, 2007). Additional sources of sulfur are discussed in Box 5-4.

The STAs have limited effectiveness in removing sulfate. Pietro et al. (2009) showed that sulfate removal ranged from 5 percent in STA-1W, 19 percent in STA-3/4, 43 percent in STA-5, and 67 percent in STA-6, with an average of about 10 percent. In general, the STAs receiving the lowest concentrations of sulfate in inlet waters were most effective in removing sulfate.

Linkages Between Sulfur and Mercury

Since the early 1990s mercury contamination has been recognized as a critical health issue for humans and wildlife that consume fish from the Everglades. The state of Florida has advisories that either ban or restrict consumption of nine species of fish from more than 3,000 square miles (65 percent of the total area) of the Everglades (Scheidt and Kalla, 2007). Advisories include a ban on consumption of largemouth bass that exceed 14 inches, and fishing for consumption is not advised in the Everglades. In addition to those related to human health, there are concerns that elevated exposure of mercury might harm piscivorous birds and the Florida panther, which may impact breeding success.

In many respects the Everglades is an ideal environment to promote the

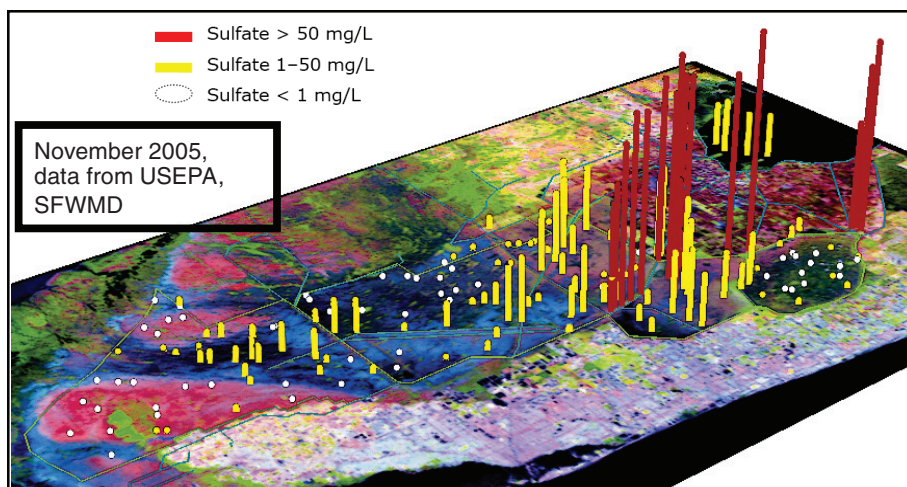

FIGURE 5-14 Concentrations of sulfate in surface water in the Everglades during November 2005. White dots indicate sulfate <1 ppm, yellow bars indicate sulfate between 1 and 50 ppm, and red bars indicate sulfate is >50 ppm.

SOURCE: Scheidt and Kalla (2007).

transport, transformations, and trophic transfer of mercury, resulting in elevated concentrations of methyl mercury in fish. Warm conditions and abundant rainfall contribute to elevated wet deposition of mercury in South Florida, among the highest of regions monitored in the United States (NADP, 2009). In the Everglades more than 95 percent of the mercury inputs are from atmospheric deposition (Landing et al., 1995; EPA, 1996; Guentzel et al., 1998, 2001). Due to the wetland environment, the Everglades are characterized by elevated concentrations of dissolved organic carbon, with particularly high concentrations in the EAA and concentrations decreasing downgradient to the south. This dissolved organic carbon binds mercury, enhancing its transport (Aiken et al., 2003) but also likely decreasing its bioavailability. The warm water temperatures, the large supply of biodegradable organic carbon and reducing conditions, and elevated inputs of sulfate in the Everglades promote sulfate reduction and the net methylation of ionic mercury. Finally the Everglades is extremely low in nutrients (oligotrophic), which facilitates the bioaccumulation of methyl mercury to high concentrations in biota (Pickhardt et al., 2002; Chen and Folt, 2005).

Sulfur dynamics appear to be an important spatial controller of methyl mercury production in the Everglades. At low surface concentrations of sulfate

BOX 5-4
Sources of Sulfur in the Everglades

There have been few studies on the sources of sulfate to the Everglades (Wright et al., 2008; Gabriel, 2009). Potential sources include atmospheric deposition, deep groundwater, and sulfur supplied from the Everglades Agricultural Area (EAA). Inputs of atmospheric sulfate deposition are small compared to fluxes in canals. Therefore, atmospheric deposition is a limited component of sulfate contamination in the Everglades. Deep groundwater exhibits high sulfate concentrations and could potentially be an important source of sulfate. However, deep groundwater is not geochemically consistent with canal water, and it is not thought to be an important source. There have been few mass balances of sulfur for the Everglades. Schueneman (2001) concluded that Lake Okeechobee and soil mineralization (the degradation of soil organic sulfur) were the largest sources of sulfate to the Everglades. Gabriel (2009) conducted a preliminary mass balance of sulfur for Lake Okeechobee, the EAA, Water Conservation Area (WCA)-1, and WCA-2 for wet (2004), dry (2007), and intermediate (2003) years. His analysis showed that atmospheric deposition was a small input, and evasion of reduced sulfur gases was a minor loss. During the intermediate and wet years, Lake Okeechobee was a net source of sulfate. The WCAs were generally net sinks for sulfate inputs. Based on canal water fluxes, the EAA was a large net source of sulfate during the wet and intermediate years and a slight sink during the dry year. Gabriel's analysis suggests that soil sulfur mineralization and direct agricultural application were important sulfur sources for the EAA and the annual harvest of sugar cane was an important sulfur loss. Although soil sulfur oxidation is clearly an important source of sulfate to downstream drainage waters, relatively little is known about controls on this source and how it has varied over time. Using sulfur stable isotope measurements, it appears that sulfur applied for agriculture is a major contributor to the excess sulfate concentrations in the Everglades (Bates et al., 2002). However, the relative contribution of recent vs. legacy sulfur additions to sulfate concentrations in the Everglades is not clear.

(<10-20 ppm) methylation is sulfate limited (Figure 5-15), and under these conditions increases in sulfate will stimulate methylation of ionic mercury (Gilmour et al., 2009). This sulfate-limited condition coincides with sulfide concentrations below 0.2-0.3 ppm in sediment porewaters. At high concentrations of surface-water sulfate (>10-20 ppm) and/or high concentrations of sulfide (>0.2-0.3 ppm), production of methyl mercury becomes curtailed because of immobilization of ionic mercury by sulfide (Benoit et al., 2003). In the northern Everglades the high supply of sulfate coupled with reducing conditions result in high concentrations of sulfide in wetland porewaters (often exceeding 1 ppm), which may limit methyl mercury concentrations (Scheidt and Kalla, 2007). With decreases in sulfate and sulfide concentrations there is an increase in methyl mercury production rate in WCA-2B and -3A with subsequent decreases through Everglades National Park toward the south (Gilmour et al., 2007).

An additional factor that may influence the spatial patterns in fish mercury

Sulfate-MeHg Response

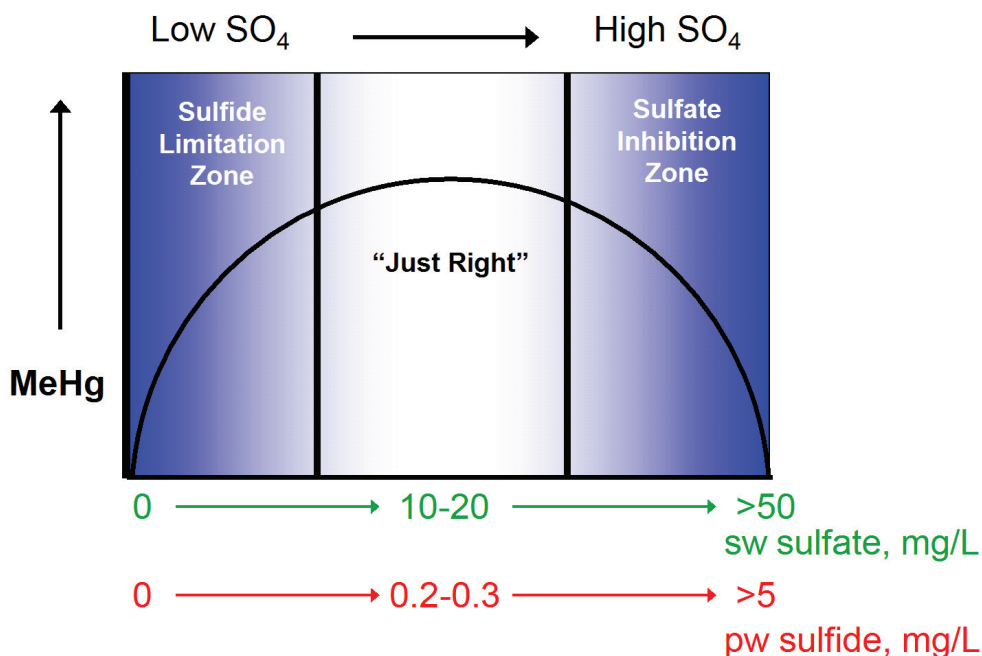

FIGURE 5-15 Conceptual diagram showing the response of methylation of mercury to varying sulfate concentrations. At low concentrations of sulfate, methylation is stimulated; at higher sulfate concentrations, the production of high concentrations of sulfide inhibits methylation.

SOURCE: Modified from Gilmour et al. (2009).

in the Everglades is phosphorus supply. Water concentrations of phosphorus exhibit a distinct decreasing gradient north to south due to inputs from the EAA (Scheidt and Kalla, 2007). This elevated supply of phosphorus increases aquatic productivity, which may result in “biodilution” of fish mercury (Pickhardt et al., 2002; Chen and Folt, 2005). However, it does not appear that this hypothesis has ever been tested for the Everglades.

The Everglades mercury problem arises from the convergence of two contaminant sources (mercury and sulfate). Ecosystem-wide sampling indicates that zones of elevated methyl mercury production appear to be controlled by sulfate transport, which varies in time and space. Increases in water discharge since

the mid-1990s appear to have increased sulfate transport southward, resulting in mercury contamination in the southern portions of the Everglades (Krabbenhoft et al., 2009).

Possible Approaches to Decrease Sulfur Contamination and Research Needs

Previous mass balance studies have demonstrated the importance of the EAA as a major source of sulfate to the Everglades. Transport of sulfate southward largely occurs via canal discharge. To date there has been limited effort to control or restrict sulfate contamination in the Everglades. Watershed BMPs could be implemented in the EAA to decrease sulfate loads. Recently, Ye et al. (2009) found that rates of sulfur application commonly used in the EAA do not significantly decrease the pH of soils and may not be effective in enhancing the availability of phosphorus. Application of sulfur could be limited in the EAA to the minimum quantity needed for sustained crop yields. Sulfur application (e.g., gypsum [CaSO_4] for pH adjustment, sulfur based fungicides, sulfur containing fertilizers) could also be minimized.

An opportunity to mitigate sulfur contamination may result from the purchase of land in the EAA from the U.S. Sugar Corporation. Taking EAA land out of cultivation should decrease both land application of sulfur and soil oxidation of sulfur associated with soil mineralization, limiting two of the most important sources of sulfate to the Everglades. The initial flooding of lands that were formerly in agriculture could likely result in a very large flux of phosphorus, sulfate, mercury, and other contaminants in drainage waters, creating a short-term environmental problem. If EAA soils are re-wetted, detailed monitoring should be conducted to characterize the extent of this disturbance. However, over the long-term prolonged flooding and saturation of soil should stimulate the accumulation of soil carbon and reducing conditions and limit the mobilization of sulfate.

Restoration of sheet flow within the Everglades ecosystem will help protect sensitive areas like the WCAs, Everglades National Park, and Big Cypress National Park from the effects of sulfate contamination. Canals promote distant transport of sulfate under oxidizing conditions. The re-establishment of sheet flow should promote sequestration of sulfur (as sulfide) under more reduced conditions and should decrease the transport of sulfate.

STAs have not been designed to remove sulfate, and, in fact, monitoring data suggest that STAs have limited effectiveness in removing sulfate. Research could be conducted to investigate how STAs can better remove sulfate, within the context of the primary objective of removing phosphorus. Possible approaches might include increasing the hydrologic residence time in STAs, using plants

that are more effective in sequestering sulfur, and using chemical amendments such as iron.

It appears that some planned hydrologic improvements in the CERP may have the undesired consequence of enhancing transport of sulfate to the southern more pristine portions of the Everglades, increasing mercury contamination in these areas. For example, within the proposed eastern flow-way, water from WCA-2 is transferred to Lake Belt storage areas prior to discharge into Everglades National Park south of Tamiami Trail. As a consequence, increasing (or changing) discharge patterns without considering associated water quality may exchange one problem for another.

CALCIUM, ALKALINITY, AND SPECIFIC CONDUCTANCE

The related issues of the supply of calcium concentrations, alkalinity, and specific conductance in the water quality of the Everglades have received some attention, but they may deserve more careful consideration as factors in ecosystem restoration. The effects of elevated conductivity on native vegetation and the implications of changing calcium concentrations on phosphorus are discussed below.

Effects on Wetland Biota

Waters draining the Everglades are thought to be historically soft. Harvey and McCormick (2009) found that the development of thick, low-hydraulic-conductivity peats isolated surface water and shallow groundwater from deep groundwater with higher ionic strength.

In the northern portions of the Everglades Protection Area (i.e., LNWR, WCA-2), water near the perimeter canals is elevated in specific conductance, with values in the range of 1,000 $\mu\text{S}/\text{cm}$ (Surratt et al., 2008; Harvey and McCormick, 2009). Canal water discharging into the LNWR has specific conductance values up to two times greater than interior waters (231.5 $\mu\text{S}/\text{cm}$ vs. 121.8 $\mu\text{S}/\text{cm}$) (USFWS, 2009e). This condition creates a zone of elevated surface-water specific conductance extending up to 2.8 miles into the LNWR and is associated with the absence of yelloweyed grass (*Xyris* spp.), a key indicator plant for undisturbed communities. The conductivity of water in the interior of WCA-2A is generally in the range of 1,000 $\mu\text{S}/\text{cm}$; in contrast, within Everglades National Park, specific conductances are rarely above 600 $\mu\text{S}/\text{cm}$, despite thin peat and greater surface water-groundwater exchange in that region. The input of waters with high concentrations of cations from the EAA into the northern WCAs has been demonstrated in spatial analyses of calcium concentration in the soil (Rivero et al., 2007) and occurred as far back as the 1940s.

There is some evidence to indicate that elevated mineral content in the surface waters of the areas receiving canal waters from the EAA may have significant impacts on the ecology of these areas. Experimental work suggests that some characteristic species, including *Rhynchospora spp.*, *Xyris smalliana.*, and *Eriocaulon aquaticum* germinate and grow better under unenriched (low calcium, phosphorus) conditions and are typically found only in softwater areas (R. Gibble, USFWS, and P. McCormick, SFWMD, personal communication, 2009). In northern peatlands, species' distributions are well known to be strongly influenced by calcium concentrations (Glaser, 1992; Bridgham et al., 1996; Payette and Rochefort, 2001), with large changes in plant community composition as calcium concentrations decrease below 10 ppm. However, the role of calcium in Everglades plant ecology has received very little attention, and so it is not clear whether the patterns observed in the northern peatlands is relevant here.

There is stronger evidence that periphyton communities are altered by changes in water hardness. Swift and Nicholas (1987) showed that calcium-enriched waters affected by canal and agricultural drainage had a lower overall diversity of algae and cyanobacteria than the softwater interior-marsh sites and were dominated by filamentous cyanobacteria and other characteristic "pollution indicators," in contrast to the desmid and acid-preferring species of diatoms found in the softwater sites. Harvey and McCormick (2009) reported similar results in the LNWR. Paleocological data (Slate and Stevenson, 2000) show that diatom species preferring acidic conditions were more widespread in the pre-drainage Everglades than currently. Contemporary data also show that calcareous communities are more common in the more minerotrophic waters of the southern Everglades. Studies of food web relationships suggest that a transition from the diatom-desmid community to a calcareous community has effects on fish species and food web structure (Williams and Trexler, 2006), although these authors found that the dominant detritivores appear to be feeding on a mixture of periphyton species from both diatoms and cyanobacteria.

Calcium Trends and Implications

In contrast to the pattern of elevated calcium and alkalinity observed in the WCAs in association with inputs from the EAA, Lake Okeechobee has shown trends of decreasing calcium concentrations since the 1970s (Figure 5-16). Calcium concentrations in the lake have decreased from 45-50 ppm in the 1970s to 30-35 ppm in 1999, a trend correlated with a slight decrease in pH and alkalinity and an increase in temperature. This pattern is likely due to a decrease in back-pumping of calcium-enriched water from the EAA and a trend toward wetter conditions, which lead to lower concentrations of lake calcium (Walker, 2000; Zhang et al., 2007).

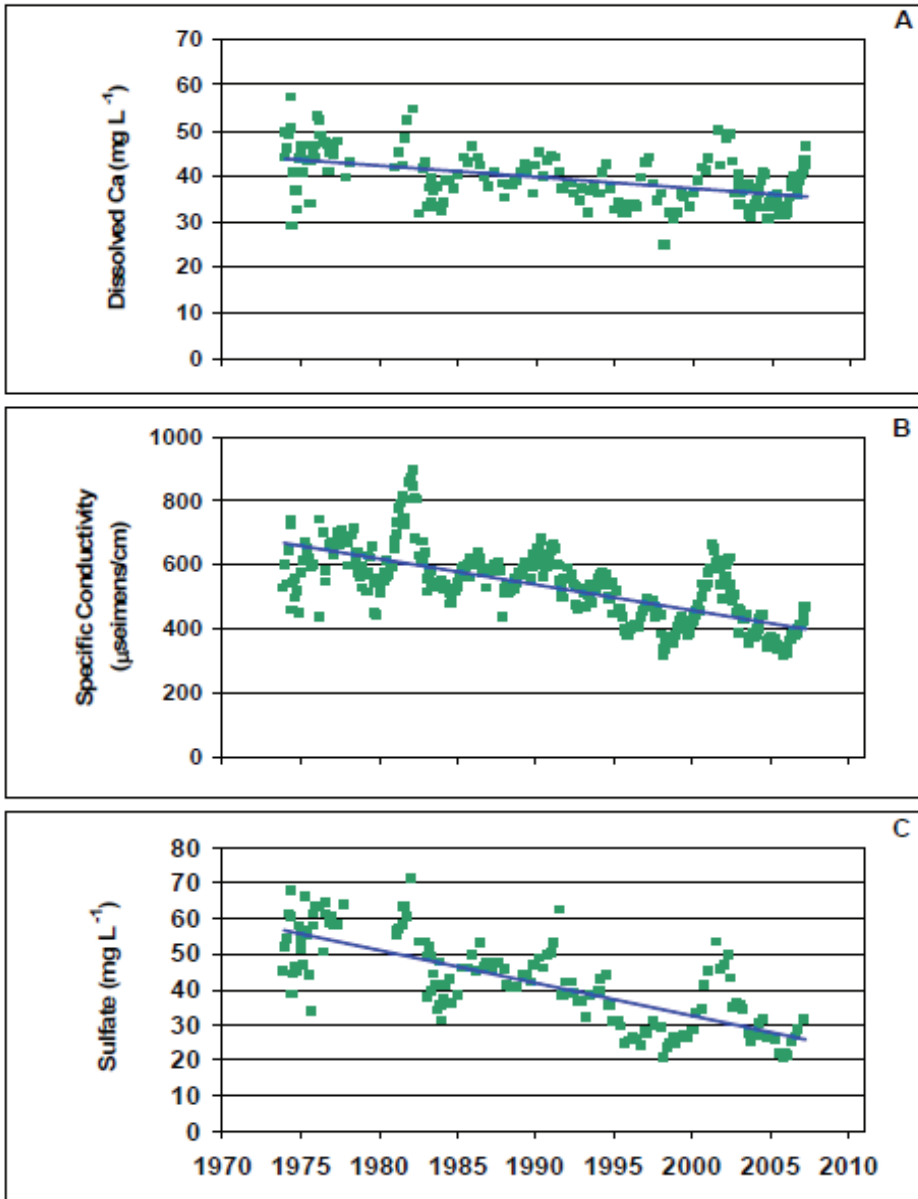

FIGURE 5-16 Monthly average values of (A) calcium, (B) specific conductivity, and (C) sulfate at eight long-term monitoring stations in Lake Okeechobee.

SOURCE: Zhang et al. (2007).

The role of calcium in the lake is strongly linked to the fate of phosphorus, as 58-70 percent of the phosphorus accumulating in the bottom sediments is bound to calcium and magnesium, and the fraction of phosphorus in the benthic sediments that is bound to calcium also shows a decreasing trend (Walker, 2000). The settling rate of phosphorus in the lake is strongly correlated with calcium concentrations (Figure 5-17), so decreasing inputs of calcium to the lake results in higher quantities of total phosphorus maintained in the lake water column. Calcium loading would appear to be an important component of the phosphorus management of the lake (Walker, 2000). This mechanism is likely associated with precipitation of calcium carbonate and the immobilization of phosphorus by sorption and flocculation. Precipitation of calcite likely facilitates the removal of turbidity, but long-term declines in calcium carbonate precipitation could enhance the persistence of phosphorus and turbidity in the lake.

Changes in the dynamics of calcium may also have implications for the long-term success of the STAs. Short-term immobilization of phosphorus in the STAs seems to occur by biological removal by periphyton and macrophytes and

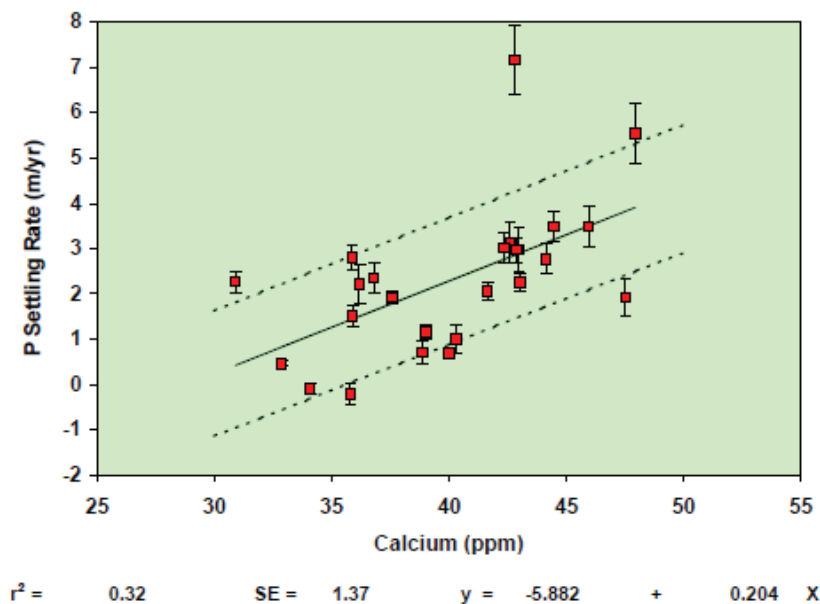

FIGURE 5-17 Relationship of phosphorus settling rate in Lake Okeechobee to calcium concentration in the water column, based on data from 1973 to 1999.

SOURCE: Walker (2000).

particulate settling. However, over the longer term it is likely that immobilization by calcium is important. STAs exhibit net retention of alkalinity, probably largely as a result of calcite precipitation (W. Walker, consultant, personal communication, 2009), and phosphate is readily co-precipitated with calcite (Wetzel, 2001; Reddy and Delaune, 2008). Walker (2009) reported outflow TP concentrations from the STAs that were highly correlated with inflow calcium concentrations, showing the importance of calcium as a control on water column TP. Long-term decreases in the inflow of calcium to STAs associated with changes in agricultural activities in the EAA will likely decrease the formation of calcite and may limit associated immobilization of phosphorus.

Research Needs

This brief review suggests that calcium and alkalinity may play a larger role in controlling both phosphorus management and the composition of the biota than has been previously recognized. It is important to determine the extent to which changes in conductivity alone, separately from phosphorus enrichment, cause undesirable changes in both the periphyton mat and in the macrophyte communities. In addition, research should be directed toward understanding the co-variation and dynamics of conductivity and other pollutants (phosphorus, sulfate) to verify the suggested utility of conductivity alone as an indicator of polluted water impact (Harwell et al., 2008; Surratt et al., 2008). Most of the research on the extent and impacts of high-conductivity water on plant and periphyton communities has been done within the LNWR; it is important to understand the extent of impact of high-conductivity canal waters on other receiving areas. Finally, the potentially important role of calcium as a control on phosphorus chemistry both within Lake Okeechobee and the STAs deserves further attention, as tradeoffs in water quality management may be necessary.

CONCLUSIONS AND RECOMMENDATIONS

Ten years after the CERP was launched, “getting the water right” is proving to be more difficult and expensive than originally anticipated. It has taken decades (more than 60 years) for the ecosystem to degrade to its current state, and it will likely take a similar timeframe or longer to restore. Legacy phosphorus storages in the Lake Okeechobee watershed, the lake itself, and the EAA suggest that current phosphorus release rates into the system will persist for decades. **Attaining water quality goals throughout the system is likely to be very costly and take several decades of continued commitment to a systemwide, integrated planning and design effort that simultaneously addresses source controls, storage, and treatment over a range of timescales.**

Additional information on phosphorus mass balances, particularly within the EAA, are needed to support effective decision making. NRC (2008) recommended a systemwide accounting for phosphorus and other contaminants such as sulfur, nitrogen, calcium, and mercury, and this remains a pressing need. There are notable gaps in the published phosphorus budgets between Lake Okeechobee and the inflows to the STAs and also in the contributions from atmospheric deposition for phosphorus and other elements. The lack of information synthesis of inputs and pathways of phosphorus and other contaminants in key areas, such as the Everglades Agricultural Area, hinders the development of targeted strategies to improve water quality management.

The current acreage of STAs, as managed, is not sufficient to treat existing water flows and phosphorus loads into the Everglades Protection Area. Although new construction of STAs is underway in Compartments B and C, these STAs are located far from where the recent Consent Decree violations have occurred. With increased volumes of water planned for the CERP, substantially more water quality treatment and/or additional load reductions will be needed if the new flows are to meet the water quality criteria. If these new CERP loads are addressed with STAs alone, an estimated 54,000 additional acres of STAs will be required, costing approximately \$1.1 billion to construct, \$27 million per year to operate and maintain, and approximately \$1.1 billion to refurbish every 20 to 25 years (2010 dollars). Additional STAs will further increase the large cost of restoration (last estimated at nearly \$13 billion) and add to the fiscal challenges of federal and state agencies, although additional source control measures could reduce the magnitude of this cost increase. EPA's recently announced phosphorus and nitrogen water quality standards for lakes, rivers, and canals introduce additional technical and financial challenges.

The SFWMD should complete a comprehensive scientific, technical, and cost-effectiveness analysis as a basis for assessing potential short- and long-term restoration alternatives and for optimizing restoration outcomes given state and federal financial constraints. This analysis is needed to facilitate management decisions that focus on improving systemwide water quality, bringing the watershed into compliance with the Lake Okeechobee TMDL, and addressing recent violations of the Consent Decree. In addition to considering additional treatment and source control, this analysis should evaluate urban and agricultural water supply management approaches and accelerated sequencing for seepage management projects to determine whether changes could address water quality and water quantity concerns in a more efficient manner.

A rigorous research, analysis, and modeling program is needed to develop improved best management practices and to examine the long-term sustainability and performance of STAs to meet the desired outflow water quality. To

support the comprehensive scientific, technical, and cost-effectiveness analysis recommended above, additional research is needed in the following areas:

- **STA sustainability and performance.** The SFWMD's extensive STA soil and water quality monitoring program should be supported by a systematic research program that evaluates the long-term ability of STAs to sustain or improve upon their current level of functioning. Further research should examine the biogeochemistry, vegetation dynamics, and hydrology of the STAs, and should couple the resultant data with predictive models to improve performance and support management decisions. Useful improvements could also be realized through an external peer review of the STA research and monitoring program, including the design criteria and modeling efforts.

- **Source control effectiveness.** A rigorous research, monitoring, and modeling program focused on developing improved BMPs is needed to improve the efficiency of phosphorus source control efforts and to inform systemwide phosphorus management decisions. Long-term monitoring of the efficacy and costs of BMP implementation across multiple sites will be required to evaluate source control practices across variable hydrologic, geomorphologic, and soil regimes present in the South Florida ecosystem and to validate and build confidence in predictive models.

Given that restoration as originally envisioned in the CERP remains decades away and the ecosystem continues to decline, CERP agencies should conduct a rigorous scientific analysis of the short- and long-term tradeoffs between water quality and quantity for the Everglades ecosystem. The committee does not endorse such tradeoffs at this time, because scientific analyses to explain the repercussions of such decisions are lacking. However, the scientific analysis of potential tradeoffs is critical to inform future water management decisions, including the prioritization of projects. In particular, the analysis should address the following questions:

- What are the short- and long-term consequences of providing too little water to the Everglades ecosystem but maintaining sufficient quality?
- What are the short- and long-term consequences of providing water of lower quality to the Everglades ecosystem but maintaining sufficient flows?
- Are the negative consequences reversible, and if so, within what timeframes?

Effective water quality management would be best served by consideration of a multi-contaminant approach in the future. Water quality conditions in the Everglades are affected not only by the input of contaminants, but also by the

inputs of other elements that alter their behavior. For example, the bioavailability of mercury and its accumulation in fish and other wildlife appears to be controlled not only by inputs of mercury, but also by the supply of sulfate, phosphorus, and dissolved organic carbon. Likewise the transport and removal of phosphorus may be coupled with the supply of calcium in Lake Okeechobee, the STAs, and other portions of the Everglades. Additional research is also needed to clarify the linkages between water quality constituents to support sound multi-contaminant water management decisions.

6

Use of Science in Decision Making

A key tenet of the Everglades restoration effort is that reliable scientific information will guide critical engineering and ecosystem management decisions. This principle is written as background for the Programmatic Regulations, the legal document that guides the implementation of the Comprehensive Everglades Restoration Plan (CERP): “The definition of restoration recognizes implicitly that science will be the foundation of restoration, but it also assumes . . . that in all phases of implementation of the Plan both restoration and the other goals and purposes of the Plan should be achieved” (33 CFR §385). The Senate Committee on Environment and Public Works (Senate Report No. 106-362) also wrote: “The Committee expects that the agencies responsible for project implementation report formulation and Plan implementation will seek continuous improvement of the Plan based on new information, improved modeling, new technology and changed circumstances.” Given the enormous scope and complexity of the restoration effort, the success of the CERP depends on strategic, high-quality, responsive, and sustained science and an effective, adaptive management framework.

In this chapter, the committee reviews scientific support for Everglades restoration from several perspectives. This chapter builds upon prior reviews of this topic by the National Research Council (NRC, 2007, 2008). First, the progress on the implementation of an adaptive management program is discussed, and remaining challenges are identified. Next, recent progress in the monitoring and assessment program and related reports are reviewed. The role of research to help resolve critical uncertainties is then described, focusing on examples of climate change science and the role of flow to support essential characteristics of the ridge and slough system. The committee then evaluates the effectiveness of current modeling tools. Finally, recent tools for assessing ecosystem services are reviewed for their potential value to restoration decision making.

ADAPTIVE MANAGEMENT

Adaptive management is “a structured management approach that links science to decision-making in order to improve the probability of restoration success” (RECOVER, 2010a). In recognition of the many uncertainties inherent in restoring the Everglades, adaptive management has always been a fundamental premise of CERP planning and implementation. Use of an adaptive management approach was authorized by the Water Resources Development Act of 2000 (WRDA 2000), and development of a CERP Adaptive Management Program was required in the 2003 Programmatic Regulations.

Instituting CERP adaptive management has largely been the purview of the RECOVER Program (Box 2-3). As described in previous NRC reports (NRC, 2003c, 2007, 2008), development of an adaptive management framework has been an important CERP accomplishment comprising many interrelated activities. Products include programmatic documents describing the adaptive management process and all aspects of performance assessment, including a monitoring and assessment program (RECOVER, 2004, 2005a,b, 2006a,c,d, 2007b, 2009, 2010a); conceptual ecological models to support monitoring and assessment (e.g., Ogden et al., 2005); an information and data management system along with the Interagency Modeling Center to support assessment and planning aspects of decision making; and a system status reporting process that establishes a baseline for long-term perspective of restoration impacts and effectiveness (RECOVER, 2006b, 2007c, 2010b).

Now that the foundations of the CERP adaptive management framework are largely in place, RECOVER has focused on producing guidance to ensure effective functioning of the adaptive management process. A *Draft Comprehensive Everglades Restoration Plan Adaptive Management Integration Guide* (RECOVER, 2010a) has been through several iterations and was recently made available for public comment. As laid out in that document, the elements of adaptive management reside in a series of “activities” (Figure 6-1) that promote learning and adjustment as the ecosystem responds to restoration practices.

Previous NRC reports (NRC, 2007, 2008) provide detailed evaluations of adaptive management activities such as restoration goals (Activity 2), uncertainties (Activity 3), conceptual models and performance measures (Activity 4), and monitoring and assessment (Activities 6 and 7). In this section, the committee evaluates recent progress and challenges in implementing other CERP adaptive management activities, focusing in particular on stakeholder engagement and interagency collaboration, integration of adaptive management principles into alternative development and implementation, feedback to decision making, and adjustment (Activities 1, 5, 8, and 9 in Figure 6-1).

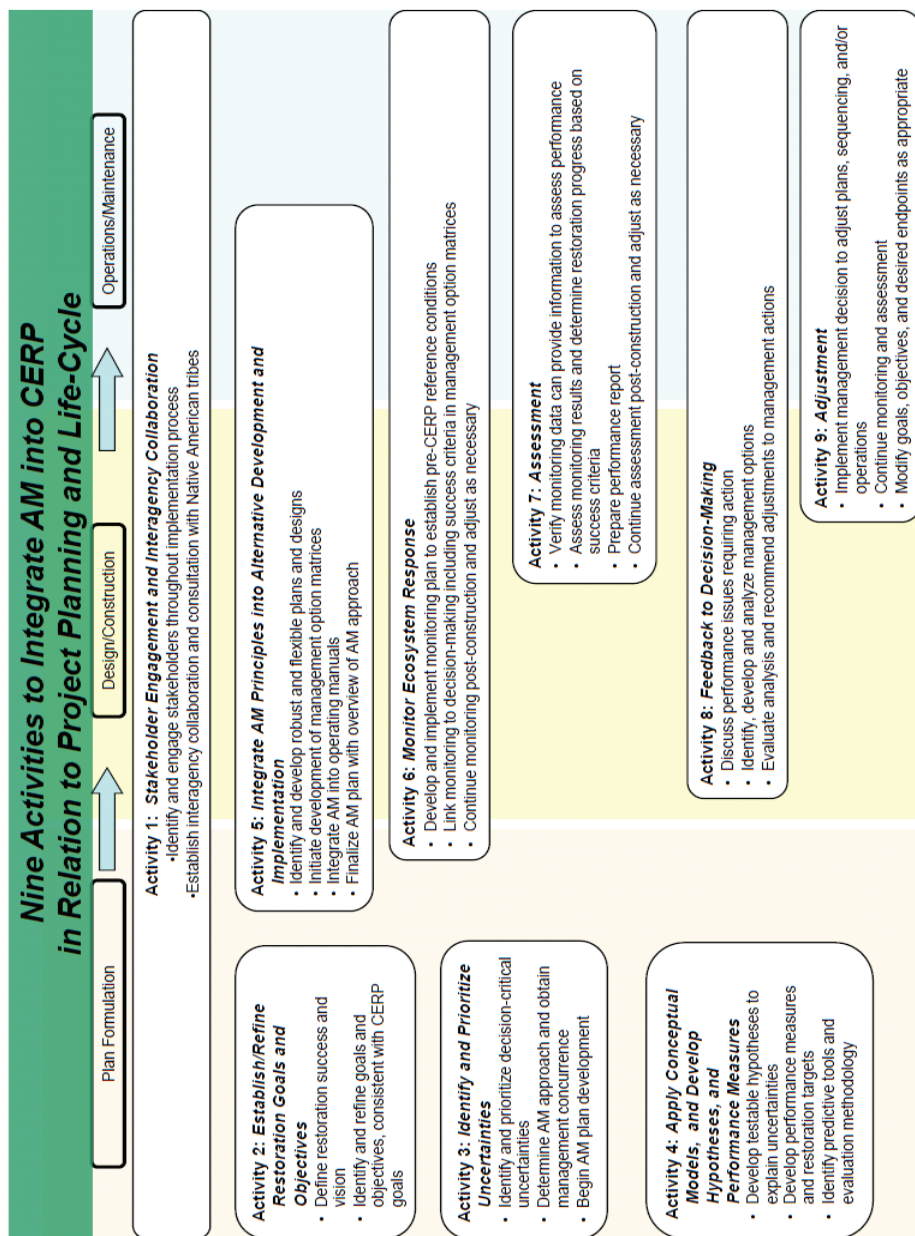

FIGURE 6-1 Nine activities to integrate adaptive management into the Comprehensive Everglades Restoration Plan.

SOURCE: RECOVER (2010a).

Activity 1: Stakeholder Engagement and Interagency Collaboration.

Stakeholder processes are particularly challenging in a program of such broad scope and duration as the CERP; interested parties span the full range of jurisdictions from local to federal agencies and tribal governments, and social scales span local residents to national interest groups. As discussed in RECOVER (2010a), CERP engagement with stakeholders runs the gamut from simply providing information to consultation to collaboration. A successful stakeholder process should appropriately match the level of engagement to each interested party and provide adequate resources to maintain that process as long as needed.

The 66 signatories to the CERP conceptual plan and CERP authorization in WRDA 2000 are testimony to initial broad public and agency support for Everglades restoration. Since that time stakeholder conflicts and agency delays have led to repeated project delays and cost overruns that have threatened to bring meaningful restoration to a standstill (NRC, 2007, 2008). Although stakeholder conflicts are inevitable in a project with as many affected parties as the CERP, the pattern is symptomatic to some extent of inadequate or inappropriate engagement with tribal nations and public stakeholders. RECOVER staff have also identified non-agency stakeholder engagement and collaboration as a particular challenge in implementing adaptive management for the CERP (LoSchiavo, 2009).

In particular, the Federal Advisory Committee Act (FACA; 5 U.S.C. Appendix 2) restricts the ways in which CERP planners can interact with non-agency stakeholders. The U.S. Army Corps of Engineers (USACE) CERP staff have been advised by legal counsel that collaboration with non-agency stakeholders, defined as a two-way dialogue and working together to define and solve problems, is not permitted under FACA in CERP meetings convened by a federal entity. Instead, such collaboration is only permitted through meetings convened by non-federal entities or a group established under a FACA exemption, such as the South Florida Ecosystem Restoration Task Force (RECOVER, 2010a). Thus, it appears that strict interpretation of FACA, which was originally intended to ensure that advice delivered to the government is objective and accessible to the public, may be hindering a more inclusive planning processes and improved stakeholder involvement. A recent NRC report on public participation in environmental assessment and decision making concluded that when done well, public stakeholder participation can improve the quality and credibility of decisions and the capacity of all involved in the policy process; but the study also found that when poorly done, participatory processes can make matters worse (NRC, 2008). This report recommended a “best-process” regime that includes monitoring of stakeholder processes to gauge effectiveness and adoption of alternative tools and techniques as warranted.

Ironically, there is no learning component to the stakeholder engagement guidelines in the CERP Adaptive Management Implementation Guide and there is no evidence that the CERP Outreach Program responsible for stakeholder engagement has undertaken any formal self-assessment since publication of the CERP Outreach Management Plan in 2001. As a result, it is not possible to rigorously evaluate whether CERP public participation processes are making things better or worse, whether they are adequately resourced, or how they could be improved. The USACE and SFWMD should formally evaluate CERP public participation processes, compare them to other models (for example the USACE's Shared Vision Planning process), strengthen public outreach and public participation efforts, and implement a process of effectiveness monitoring and iterative improvement.

Interagency coordination of CERP science and adaptive management occurs at many levels. RECOVER includes representatives from seven federal agencies, the Miccosukee and Seminole tribes, and three state agencies. The CERP monitoring and assessment program (MAP) comprises at least 36 monitoring components involving 25 different entities. The effectiveness of and continuing improvement to the MAP (discussed in more detail later in the chapter) is evidence that scientific research, monitoring, and assessment are being relatively well coordinated. However, as the CERP moves from planning to project construction, differences have become evident both within and among agencies in how they define and apply adaptive management (LoSchiavo, 2009). For example, some CERP scientists have expressed concern that USACE engineers may not adequately value learning when considering benefits and costs of alternative project designs. This is evident in the USACE *Implementation Guidance Memorandum for Ecosystem Restoration* (August 31, 2009), which equated an "Adaptive Management Plan" with a "Contingency Plan" and indicated that the sole purpose of monitoring is to inform whether a project is performing adequately or not and whether modifications are needed to attain project benefits. This would seem to exclude any consideration of learning benefits to future projects obtained through well-designed adaptive management. Given the differences in agency missions, technical strengths, and approaches to restoration, disagreements can emerge in how uncertainties are prioritized or the appropriate scope of adaptive management both at project and programmatic levels. Although not unexpected, these disagreements ultimately impact project design and monitoring and assessment activities. For this reason, the CERP Adaptive Management Integration Guidance document represents an important step toward developing more consistency in how adaptive management is defined and applied during CERP program and project implementation to achieve restoration and learning benefits.

Activity 5: Integrating Adaptive Management Principles into Alternative Plan Design and Implementation

As represented in Figure 6-1, incorporating CERP adaptive management to alternative plan design and implementation continues even as other activities such as monitoring, assessment, feedback to decision making, and adjustment occur. In initial CERP projects, adaptive management has been integrated to varying degrees into evaluation of project alternatives and ultimate project design and operation. In the case of Picayune Strand, a monitoring and assessment program is in place to evaluate project effectiveness but only loosely linked to adaptive management in terms of stated uncertainties, hypotheses, or measures of restoration performance (USACE, 2004). The Indian River Lagoon Project includes an extensive Adaptive Assessment and Monitoring Program for monitoring ecological and water quality responses, but the documents imply that the intent is mainly to assess project effectiveness, and they make no mention of specific ecological uncertainties or hypotheses to be examined, nor how the information would inform adaptive management (USACE, 2004). The Draft Project Implementation Report (PIR) for the C-111 Spreader Canal, Western Project discusses adaptive management and incorporates elements of adaptive management into the monitoring plan and project operating manual, but it provides little guidance on which key scientific uncertainties should be addressed through monitoring and adaptive management (USACE and SFWMD, 2009a).

In contrast, the recently completed Biscayne Bay Coastal Wetlands Phase 1 Draft Integrated PIR/EIS includes a separate adaptive management plan that presents key uncertainties, management alternatives and associated costs, and hypothesis-based assessment protocols tied to specific performance measures (USACE and SFWMD, 2010a). Consistent with the notion of Incremental Adaptive Restoration (NRC, 2007), the document describes opportunities for knowledge gained in Phase 1 to be incorporated into the design of Phase 2. In the committee's view this last example comes closest to the intent of Activity 5 as envisioned in the CERP Adaptive Management Guidance Manual. Whereas typical CERP project monitoring plans only include activities not under the auspices of the MAP, which can create challenges when integrating project-level and systemwide monitoring information (Heisler and Ehlinger, 2009), the ecological monitoring plan for Biscayne Bay has been more deliberately coordinated with the MAP and will use MAP performance measures, results, and protocols whenever possible. This has led to consideration of systemwide as well as project-level performance measures and stronger programmatic ties between RECOVER's applied science efforts and project-level management (LoSchiavo, 2009).

Activities 8 and 9: Feedback to Decision Making and Adjustment

During the past decade the baseline of information and scientific understanding has expanded significantly, although major uncertainties persist regarding how the ecosystem will respond to partially restored hydrologic regimes. As projects come online, effective feedback of knowledge gained through adaptive assessment is essential to inform management and policy decisions and ultimately guide necessary adjustments to restoration goals and objectives.

With the exception of the short-duration Decomposition Physical Model and the C-111 Spreader Canal design test, the pre-CERP and CERP projects now being implemented are not active adaptive management experiments. Instead, CERP projects primarily apply passive adaptive management, where project outcomes are monitored and evaluated, and subsequent decisions regarding project operations or the design of subsequent projects are adjusted based on an improved understanding. A critical question then is whether feedback and adjustment are possible under the current governance structure.

The current structure for scientific feedback to decision making is shown in Figure 6-2. Scientists report assessment results to the Design Coordination Team (DCT), which includes representatives from the USACE, South Florida Water Management District (SFWMD), and Florida Department of Environmental Protection (FDEP). The DCT consults with *ad hoc* teams, tribal nations, and agency partners and recommends management options and actions to the Quality Review Board (QRB),¹ a group of senior decision makers from participating CERP agencies, and to the Joint Project Review Board (JPRB), which comprises senior managers from the USACE and SFWMD. Following agency and public review, decisions and adjustments are made by senior leadership in the USACE and SFWMD.

In their critique of Everglades adaptive management and governance, Gunderson and Light (2006) argue that both scientists and decision makers have been unwilling or unable to practice adaptive management because they are caught in a management trap “maintained by considerable infusions of money, which are tied to the conventional bureaucratic system. This system is governed by rules and procedures that are no longer fitting and appropriate to accomplish a highly complex and multi-objective mission. The result is that for the sake of consistency, Everglades restoration remains in a policy straitjacket” (Gunderson and Light, 2006). They characterize Everglades governance as fundamentally a top-down, command-and-control structure that has never seriously confronted

¹The Quality Review Board is a group of senior CERP agency managers that was formed by USACE and SFWMD leadership as a means to resolve issues across agencies, improve collaboration, and provide common direction to CERP staff. The QRB is not a decision-making body, although QRB participants include most senior CERP decision makers.

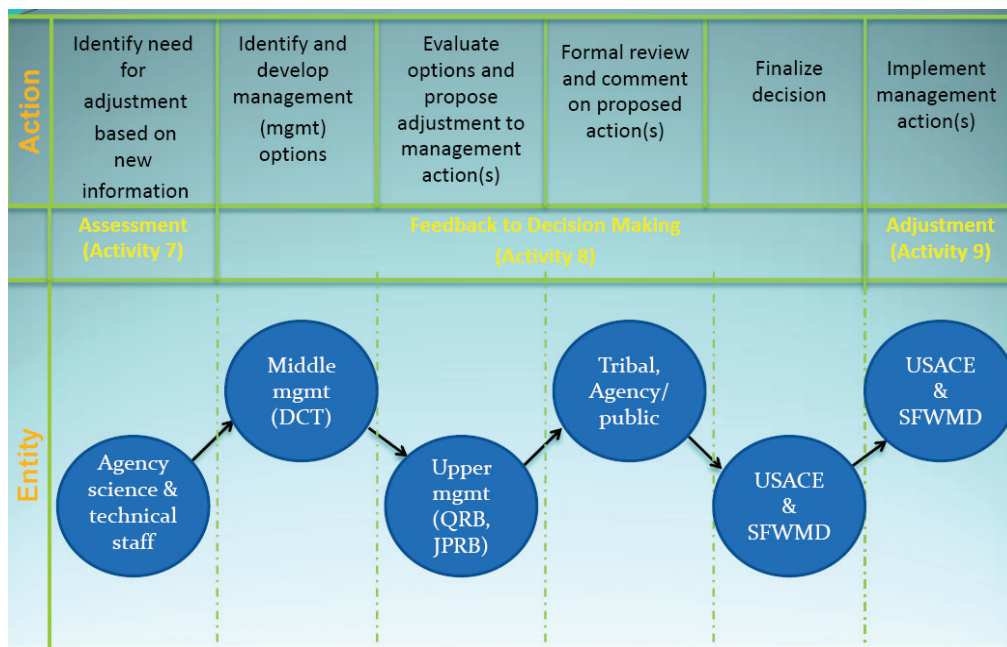

FIGURE 6-2 Simplified schematic of the current governance structure for scientific feedback to decision making in CERP.

SOURCE: USACE (2010a).

uncertainty or embraced learning through scientific management experiments. Such a governance regime, they argue, cannot be relied on to accept feedback and make appropriate course corrections. Therefore, the committee explored whether such statements hold true today.

This committee encountered strongly contrasting opinions regarding the capacity for scientific feedback to influence management and policy decisions in the current system. Some individuals complained that RECOVER has been marginalized in decision making and relegated to a passive reporting role rather than participating directly in programmatic review or decisions. Former Deputy Secretary of the Department of the Interior Lynn Scarlett observed adaptive management should be a joint enterprise between scientists and managers but that “there is no formal governance process or joint fact-finding process through which decision makers and scientists regularly collaborate and converse to shape the science agenda, discuss scientific results, and adapt and adjust practices based on those results” (Scarlett, 2010). On the other hand, senior managers

in the USACE, Department of Interior (DOI), and SFWMD maintained that CERP leadership has been receptive to new scientific guidance, pointing to examples like the collaboration between scientists and managers in developing an increased understanding of and accounting for the importance of sheet flow in restoring the ridge and slough system (discussed in detail later in this chapter) and the involvement of scientists in providing biweekly input to decision makers about ways to optimize operations of the water management system in Water Conservation Area (WCA)-3 (see also Chapter 4).

The committee has not tried to evaluate the degree to which recent management decisions have incorporated scientific information, but the effectiveness of the linkage between science and decision making is clearly an issue that should be examined by CERP leadership. Some restoration scientists suggested that the potential for scientific feedback would be increased by adding senior scientists to the Quality Review Board or by appointing senior scientists to the South Florida Ecosystem Restoration Task Force, either in voting or non-voting roles. Other alternative models proposed having independent (non-agency) scientific experts on RECOVER or perhaps an independent “chief scientist” as a way of increasing the credibility of scientists in policy and decision processes.

This committee does not have the resources or the expertise to systematically evaluate the current institutional structure or to recommend a preferred structure for ensuring effective feedback of scientific learning to management and policy decision making in the CERP. Instead, some effective strategies for incorporating science into decision making are discussed in the next section.

The predecessors of this committee have generally evaluated CERP science activities favorably, and as is discussed in more detail later in this chapter (see *Advances in Research*), this committee agrees. Predecessor committees also have emphasized the importance of linkages between science and assessment functions and decision making as a basis for adaptive management (e.g., NRC, 2003b, 2007). As discussed previously, some have suggested that these linkages could be improved by including scientists on key advisory or decision-making bodies. This is not without its drawbacks: there is some concern that scientists' credibility can suffer if they take positions of advocacy or are involved in decision making (e.g., Policansky, 1998a; Lach et al., 2003). However, some have argued that times are different now and that scientists have to undertake new roles and activities to be effective (e.g., Boesch, 1999, 2006; Lach et al., 2003). Thus, the question arises as to how best to involve scientists in decisions without affecting their credibility as scientists.

The consensus of most of the above authors seems to be that mechanisms need to be developed that provide clear communication of the science (Lach et al., 2003; Boesch, 2006). First, scientists need to be willing and able to effectively communicate their decision-relevant findings to managers and decision

makers. Mechanisms are needed for involving scientists in management and policy decisions without compromising their scientific integrity and without trying to make scientists out of policy makers and managers or making policy makers out of scientists (Guston, 2001; Lach et al., 2003; Boesch, 2006; Bois-sin, 2009). Also, clearer expression of scientific judgments and policy goals as separate but critically important aspects of environmental decision making is needed (Policansky, 1998b).

As restoration projects begin to register effects on the ecosystem, the efficacy of scientific feedback to decision making will be tested with increasing frequency. Issues such as lines of reporting and communication, resolution of scientific disagreements, stakeholder engagement, and decision authority will need to be clarified. CERP personnel are currently considering these questions, as evidenced by the March 2010 workshop, "Incorporating New Information into Decision Making." In doing so, the committee encourages the strong linkage of scientific information to policy and management considerations such that scientific judgments are clearly communicated and distinguished from identified policy goals. In other words, the committee is encouraging the development of scientific information that is relevant to policy and management considerations and the development of mechanisms to incorporate that information into policy and management decision making, while maintaining the distinction between scientific conclusions and policy and management decisions. The committee also recommends greater clarity and transparency on the part of the CERP in developing, identifying, strengthening, and describing mechanisms for integrating science into policy, management, and implementation decisions for CERP. In the committee's judgment, such clarity would benefit the participants in the decision-making process as well as stakeholders and other interested parties.

MONITORING AND ASSESSMENT PLAN

The CERP Monitoring and Assessment Plan (MAP) is a critical component of adaptive management (see Activities 4, 6, and 7 in Figure 6-1). The MAP has as its goal the development of a single, integrated and systemwide plan to be used by RECOVER and CERP agencies for holistically determining the state of the Everglades ecosystem during the restoration. The plan provides guidance to establish pre-CERP reference conditions including metrics of natural variability, assess the systemwide response to CERP implementation, and detect unexpected responses of the system. This information forms the basis for adaptive management, by providing the necessary feedback to managers to allow additional CERP refinement as the ecosystem moves toward the desired goals. The committee's last two reports (NRC, 2007, 2008) included detailed discussions on the major components of the MAP (RECOVER, 2004, 2005b, 2006d, 2007b, 2009), and

this section is focused on the MAP developments since NRC (2008) was released: MAP 2009 and the spotlight indicators. The 2010 System Status Report is also discussed briefly, although the report was released too late for a thorough review by the committee.

MAP 2009

The recent revision of the CERP MAP, Part I (RECOVER, 2009; also called MAP 2009) expands and updates RECOVER (2004; hereafter called MAP 2004) to respond to refinements in the hypotheses, allow better coordination with adaptive management, incorporate project-level monitoring, and address changing priorities. Figure 6-3 illustrates the many activities and reports that occurred after 2004 that influenced the changes seen in MAP 2009.

MAP 2009 reflects changes to the science strategy of CERP since 2004 and a much broader scope for the monitoring and assessment program. The conceptual ecosystem models (CEMs) have been further refined and combined into hypothesis clusters. These hypothesis clusters integrate stressor-response relationships and better reflect the complex functional relationships between the

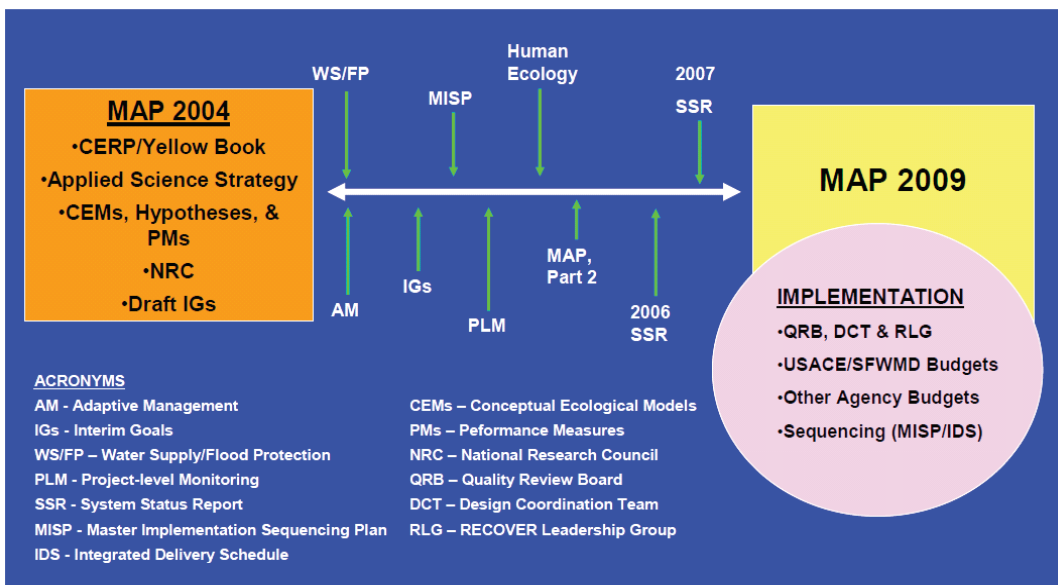

FIGURE 6-3 Factors influencing the development of MAP 2009.

SOURCE: RECOVER (2009).

performance measures, driving factors, stressors, and response variables. These revisions, and the plan in general, take into account lessons learned from the 2007 System Status Report (RECOVER, 2007c), which was the first large-scale test of the monitoring and assessment methodologies.

Another notable addition to this revision is an explicit consideration of global uncertainties, defined as “factors that have wide-ranging effects and cut across and affect the success of all restoration programs.” Included in the analysis of such global uncertainties are climate change and sea level rise, invasive exotic plants (now considered one of the high-priority issues facing the CERP), and the role of fire and changing fire regimes. While not offering in-depth analyses of each of these issues, the report does point to related and ongoing efforts to take these three critical issues into account in the overall planning for the CERP.

MAP 2009 specifically addresses the crucial role of monitoring, assessment, and communication as the basis of the adaptive management plan. The report correctly points out the fact that informed decision making is reliant on data collection and interpretation, and that hypothesis-based monitoring provides a robust basis for these activities. The plan discusses how each of the nine activities required to carry out adaptive management (see Figure 6-1) is incorporated into MAP implementation. The plan also calls for “open and inclusive” interactions with all stakeholders to ensure public and agency support for management decisions based on the monitoring and assessment results. MAP 2009 promotes the use of decision-support tools and decision frameworks to help managers apply monitoring results to management decisions.

MAP 2009 explicitly addresses the challenges of setting target and threshold levels for performance measures, particularly those used as indicators for Interim Goals (IGs). A scientifically defensible approach is taken, based on the calculation of confidence intervals around a selected measure of central tendency for each indicator variable, plus a “safety factor.” This approach takes into account a measure of the natural variability of each variable. Although the plan notes that thresholds may occur past which the system, or parts of the system, may undergo state changes that are hard to reverse, it also notes that such thresholds are very difficult to establish quantitatively. The current report simply notes this difficulty; in future versions RECOVER should develop explicit methods for specifying if and when quantitative values of thresholds can be established.

MAP 2009 carefully separates the scientific from nonscientific issues involved with implementation of the program. Nonscientific issues include the mechanisms and administrative issues for incorporating project-level monitoring data, the sustainability of the plan (in terms of financial resources), agency coordination, and the maintenance of public support through effective communication of results. The MAP explicitly recognizes and discusses the challenges of maintaining the monitoring effort. In MAP 2009, good communication of the

specific uses of monitoring information in decision making, the maintenance of strong relationships to stakeholders, and collaborative decision making are identified as crucial to the sustainability of the monitoring and assessment effort. The development of the stoplight indicator reports (see below) is a positive development that will likely enhance support for monitoring. In the previous section, the need for transparent mechanisms for incorporating science into decision making is discussed, and the MAP is an essential part of this process.

Finally, the report deals extensively with issues of data management, addressing issues of data incompatibility and data availability. While numerous platforms for storing, sharing, and documenting data are now in use, the overall program of data management is still described as “evolving.” RECOVER should address the remaining data management issues promptly to ensure that monitoring data, as they accumulate, can be effectively used in the systemwide context.

MAP 2004, which had been developed and improved with advice from NRC (2003b), was also reviewed in NRC (2007). Although NRC (2007) generally praised the approach being taken by RECOVER in designing a monitoring and assessment program, it offered specific suggestions for improvement and expressed concern about several issues. These included the development of whole-system performance measures, the development of adequate hydrologic monitoring networks and hydrologic measurements that were specifically linked to ecological components, the implementation of the MAP, and the sustainability of the MAP. These issues have been largely met in the current version of the MAP. Work on systemwide performance measures has been ongoing (e.g., Doren et al., 2009a). The U.S. Geological Survey (USGS) has extensively developed and validated the EDEN network of water depth monitoring data and its application to ecological indicators (Liu et al., 2009). NRC (2008) found that the 2007 System Status Report provided an excellent basis for further developing and applying the MAP, and the lessons learned from this exercise have been explicitly incorporated into the current plan. Finally, although RECOVER has not solved the problems of either ensuring the sustainability of the MAP or developing a seamless data management system, both topics are addressed explicitly and in depth in the current plan, indicating that progress is being made on both fronts.

The committee was impressed by the thoughtfulness and thoroughness of the MAP. The explicit description of mechanisms for incorporating MAP information into management and implementation decisions is a good feature of the report. However, a full evaluation of this aspect of the MAP cannot take place until the actual restoration progress has proceeded to a point at which it is possible to observe more completely how these monitoring and assessment mechanisms are put into practice. This committee reiterates the critical importance of the MAP for informing implementation and management decisions, as well as for providing assessments of restoration progress.

Stoplight Indicator Report

A crucial component of the MAP has been the development of indicators of restoration progress, called performance measures, which can be used to determine the effects of CERP implementation. The development and components of the set of performance measures were extensively reviewed in NRC (2008) and found to be, with some limitations noted, a well-justified, extensively documented, and comprehensive set of indicators of ecosystem status and restoration progress. However, the large number of performance measures does not lend itself to communicating ecosystem status to managers and the public. To meet this need, the Science Coordination Group, with input from RECOVER scientists, worked to develop a subset of systemwide indicators and a document that clearly communicates both the justification for the indicators and their current status (Doren et al., 2009b). This document is grounded in a series of papers published as a special issue of the peer-reviewed journal *Ecological Indicators* (Doren et al., 2009b). These papers describe both the criteria used to evaluate and select indicators and the indicators themselves (see Box 6-1). The indicators include both the desirable elements of the Everglades ecosystem and the major biotic undesirable element (invasive species). The set of selected indicators was also evaluated with respect to systems of indicators used in other large-scale restoration and environmental management programs around the United States. Explicit criteria were then developed for each indicator to assign a status level (i.e., red, yellow, or green) based on comparisons with the established target and threshold quantitative values (Figure 6-4).

The document prepared for dissemination to the public, including managers and decision makers (Doren et al., 2009b), does an excellent job of communicating the scientific underpinnings of the system and the status of each indicator. The authors give a “big picture” summary, which emphasizes the problems emanating from water quality and quantity challenges, regional issues (e.g., decline of the northern and southern estuaries), and the compounding effects of naturally occurring weather extremes. The brief reports on each systemwide indicator include maps to illustrate the status of particular indicators across the region, and individual red, yellow, or green status ratings for the component parts of each indicators (such as individual fish species for the “fish and macro-invertebrate” indicator; see also Figure 6-4). References to the scientific literature and websites are listed for access to more detailed information. Altogether, the stoplight report should greatly improve communication to both the general public and decision makers. However, rather than assuming this to be the case, the Science Coordination Group staff should systematically solicit feedback from these audiences, assess the effectiveness of the current stoplight indicators, and continue to refine and improve them.

BOX 6-1 **Systemwide Indicators**

The systemwide indicators used in assessing Everglades restoration are

- Fish and Macroinvertebrates
- Wading Birds (Wood Stork and White Ibis)
- Wading Birds (Roseate Spoonbill)
- Florida Bay Submerged Aquatic Vegetation
- Florida Bay Algal Blooms
- Crocodylians (Alligators and Crocodiles)
- Oysters
- Periphyton-Epiphyton (communities of microscopic algae and bacteria)
- Juvenile Pink Shrimp
- Lake Okeechobee Littoral Zone
- Invasive Exotic Plants

The explicit criteria used to select the above indicators are

1. Is the indicator relevant to the ecosystem?
2. Does it respond to variability at a scale that makes it applicable to the entire system or a large or important portion of it?
3. Is the indicator feasible to implement (i.e., is someone already collecting data)?
Is it measurable?
4. Is the indicator sensitive to system drivers, and is it predictable?
5. Is the indicator interpretable in a common language?
6. Are there situations where even an optimistic trend with regard to the indicator might suggest a pessimistic restoration trend?
7. Are there situations where a pessimistic trend with regard to the indicator may be unrelated to restoration activities? If so, can the responses due to these activities be differentiated from restoration effects?
8. Is the indicator scientifically defensible?
9. Can clear, measurable targets be established for the indicator to allow for assessments of success of ecological restoration and effects of management actions?
10. Does the indicator have enough specificity (strong and interpretable effect of stressor on the indicator)? Does it indicate a feature specific enough to result in management action or corrective action?
11. What level of ecosystem process or structure does the indicator address?
12. Does the indicator provide early warning signs of ecological change?

SOURCE: Doren et al. (2009a).

Stoplight-Color Legend



Red - Substantial deviations from restoration targets, creating severe negative condition that merits action.



Yellow - Current situation does not meet restoration targets and merits attention.



Green - Situation is good and restoration goals or trends have been reached. Continuation of management and monitoring effort is essential to maintain and be able to assess "green" status.

PERFORMANCE MEASURE	CURRENT STATUS ^a	2-YEAR PROSPECTS ^b	CURRENT STATUS ^a	2-YEAR PROSPECTS ^b
Wading bird Indicator Summary			Three out of the four Wading Bird Indicators are Red based on the most current data available. Overall, wading bird populations and indicators are well below recovery goals.	All four indicators have positive trends, suggesting they will move closer to recovery goals in the near future.
Ratio of Wood Stork + White Ibis nests to Great Egret nests			Current ratio is well below 30:1 considered representative of healthy nesting conditions.	This ratio appears to have stabilized and improved in some years over the past two decades.
Month of Wood Stork nest initiation			2007 initiation was in February, and mean initiation dates in past five years are well below the recovery goal of November or December.	December and January nestings have been recorded recently, suggesting improvement. Stork nests continue to fail routinely because of late initiation.
Proportion of nesting in headwaters			Proportion nesting in the headwaters was 7% in 2007, and average proportions in last five years remain well below yellow or green thresholds.	Trends in the past two decades suggest mild improvement in nesting in the headwaters.
Mean interval between exceptional ibis nesting years			This interval is now very close to the target for restoration, and has shown dramatic improvement in last decade.	The trend is positive and fairly consistent in recent years.

FIGURE 6-4 Example of application of the "stoplight" ratings to the wading birds (wood stork and white ibis) systemwide indicator.

SOURCE: Doren et al. (2009b).

System Status Report 2009

The RECOVER System Status Reports (SSRs) provide detailed assessments of the state of the Everglades ecosystem. Extensive monitoring data are compiled and analyzed to identify ecosystem trends and to provide pre-CERP reference conditions that will be used to assess CERP project-related ecosystem changes, once projects are implemented. The 2009 SSR (RECOVER, 2010b) builds upon previous system status reports by compiling and analyzing two additional years of monitoring data beyond that reported in the 2007 SSR (RECOVER, 2007c) and

by incorporating new data sources not previously used. The draft 2009 SSR was released to the public for scientific and technical review in April 2010, too late for the committee to provide an in-depth review. In addition, the systemwide synthesis chapter, perhaps the most important for the committee's evaluation, will not be available until after the document has undergone scientific and technical review. Nevertheless, a brief discussion of the 2009 SSR is provided here.

The 2009 SSR builds on the 2007 SSR, which was discussed in considerable detail in the NRC's second biennial review (NRC, 2008). As with prior system status reports, the 2009 SSR does not attempt to assess whether the CERP is meeting its goals or objectives because no CERP projects have yet been fully implemented. Also in the 2009 SSR, RECOVER not only analyzes the data within geographic modules, but also begins the process of integrating the data across geographic regions (RECOVER, 2010b). The committee did not have time for a thorough analysis of the data presented in each of the modules but it supports the conclusion in the 2009 SSR (and also echoed in NRC, 2008) that "the success of the MAP and CERP lies in the ability of this program to continue to maintain its long-term monitoring program in order to capture and account for this variability in its trend analysis so that it can effectively discriminate changes that are due to system variability from those resulting from CERP activities" (RECOVER, 2010b). Also, the committee encourages RECOVER to continue to develop and implement plans to assemble MAP-derived and other data across modules to allow for a systemwide assessment.

RESEARCH AND MODELING TOOLS TO SUPPORT RESTORATION

Substantial research progress has occurred since the CERP was launched in 1999 that has helped CERP planners understand the nature and function of the current and the historical South Florida ecosystem. In this section, the committee discusses advances in research, synthesis, and modeling that have contributed to an improved foundation for decision making. Recommendations are also presented to strengthen scientific and modeling support for restoration.

Advances in Research to Support Restoration Decision Making

Scientific support for Everglades restoration is a large and complex endeavor, carried out by agency and university scientists, with funding from CERP agencies and also the National Science Foundation. The committee did not attempt to analyze the full extent of research underway or to identify research gaps in this report, as this has been the focus of major planning efforts by both the Department of the Interior (DOI, 2005) and the Science Coordination Group (SFERTE, 2008). Instead, in this section examples of significant advances in research are

presented that have contributed to an improved foundation for decision making. Two areas that were less well understood 10 years ago—climate change and the role of flow—are discussed and recommendations are offered to strengthen the research that supports restoration.

Climate Change and the Everglades

Changing climate is a critical consideration for Everglades restoration, as discussed in detail in NRC (2008). Changing climate will likely be manifested through increases in temperature, changes in the quantity or temporal and spatial distribution of precipitation, and sea level rise, resulting in alterations in water supplies, impacts to commercial activities, perturbations to the Everglades landscape, changes in biogeochemical processes, and shifts in species distribution and biodiversity (see Box 6-2). As Everglades restoration involves large-scale

BOX 6-2 South Florida Climate Change Effects

Climate change effects in South Florida can be subdivided into four impacts: (1) sea level rise; (2) increases in temperature and evapotranspiration; (3) changes in precipitation, flooding, and drought; and (4) tropical storms, hurricanes, and extreme events.

Sea level rise

Globally sea level has been increasing in recent years at an accelerating rate. The rate of sea level rise in Florida (estimated between 2.2 and 2.7 mm/yr; NOAA, 2010; SFWMD, 2009f) is somewhat greater than the global averages. If current rates continue, sea level will increase between 0.2 and 0.24 m in Key West by 2100. Increasing sea level will likely have adverse impacts on beaches, coastal infrastructure, and wetlands due to storm surges and high tides. Sea level rise will likely compromise flood control structures, which could increase flooding in low lying areas. With sea level rise, it is likely that there will be increased salt water intrusion into wellfields and the elimination of critical groundwater for water supplies. Depending on the rate of sea level rise, there could be marked changes in some of South Florida's low elevation landscapes.

Increases in temperature and evapotranspiration

Climate scientists project increases in air temperature in South Florida, with summer temperatures predicted to increase by 1.7 to 3.9°C by 2100 (SFWMD, 2009e). Increases in temperature will likely increase rates of evapotranspiration, which will decrease the availability of water and increase competition for water among agriculture, development, and the Everglades.

water and land management and projects that are planned for several decades into the future, NRC (2008) recommended that CERP planners more rigorously and systematically consider climate change impacts as part of planning activities. Two years later, CERP planners appear to be actively engaged in addressing the potential impacts of climate change on water management in South Florida (SFWMD, 2009e; Obeysekera et al., 2010). Some of the important science developments with implication for restoration management are discussed below.

Climate and Sea-Level Trends in South Florida. SFWMD researchers (Obeysekera et al., 2010) conducted time-series analysis of the temperature and precipitation records from 1892 to 2007 for 17 stations in South Florida. They found no clear significant continuous trends in temperature or precipitation, but they did observe an interesting pattern of increasing median temperature across all

Changes in precipitation, flooding, and drought

There are no clear projections for changes in the quantity or distribution of precipitation in South Florida. Precipitation quantity could increase or decrease by as much as 20 percent. Increases in precipitation would likely compromise flood protection and could degrade wetland and coastal ecosystems. Decreases in water would increase competition for available water among agriculture, development and the Everglades, increase the threat to coastal groundwater supplies from salt water intrusion, accelerate the deterioration of the Everglades landscape, and likely increase the occurrence of fire.

Tropical storms, hurricanes, and extreme events

It is difficult to project future changes in tropical storms and hurricanes in response to changing climate. As the atmospheric temperature increases, ocean temperature and wind shear will also increase. These two factors will likely have opposing effects on tropical storms. Overall storm frequency may decrease, but the intensity of storms may increase. With decreases in the number of storms there could be changes in the quantity and distribution of rainfall. This change could affect water supplies and the South Florida ecosystem. If tropical storms and hurricanes become more intense, there is potential for damage to structures and flooding of urban coastal areas.

Implications for the CERP

In the face of these numerous challenges, NRC (2008) concluded that “Everglades restoration efforts are even more essential to improve the condition of the South Florida ecosystem and strengthen its resiliency as it faces additional stresses in the future. If ecological resilience is not restored, the possibility exists that environmental changes could precipitate rapid and deleterious state changes that might be very difficult or impossible to reverse.”

SOURCE: SFWMD (2009f).

17 stations until about 1940, followed by a decline until about 1980 and then increasing temperature until the present.

National Oceanic and Atmospheric Administration (NOAA) tidal gauge data were evaluated to assess long-term changes in sea level and changes in the occurrence in extreme tidal events at Key West (Obeysekera et al., 2010). Their analysis showed a linear increase in sea level of 2.9 and 2.7 mm/yr for the time periods 1913-1960 and 1961-2008, respectively. This rate is somewhat higher than the global average of 2.0 ± 0.3 mm/yr (White et al., 2005). The analysis also showed an increase in the probability of extreme water level events and a change in the extreme high water level of 15 cm for the recent interval.

General Circulation Model (GCM) predictions for South Florida. GCMs are used to make global, hemispherical, and continental-scale predictions of climate (e.g., temperature, precipitation, solar radiation), generally doing a better job predicting temperature than precipitation. Although GCMs may be effective tools for projection of future climate change, they have several limitations for local-scale water resource planners. Different GCMs produce different results, and there is no consensus on the “best” model. The grid size of GCMs is relatively large (~60 miles or 100 km) compared to the local scale of most watersheds. In fact, Central and South Florida is represented in many models with one or two grid cells, and these are generally depicted as mixed land-ocean cells. Some hydrologists and ecosystem scientists resort to downscaling to overcome these problems.

Obeysekera et al. (2010) evaluated the effectiveness of 16 GCMs in predicting seasonal temperature and precipitation patterns for South and Central Florida for 1961-1990. In general, the GCMs simulated the dry season precipitation fairly well, but they greatly under-predicted the wet season values and, as a result, under-predicted annual values. The GCMs did a better job predicting the measured temperature patterns; however, they generally under-predicted temperature by 2.5 to 3°C during the wet summer period.

Hydrologic Model Sensitivity Analysis of Changing Climate. Obeysekera et al. (2010) used the regional-scale South Florida Water Management Model (SFWMM) to conduct a sensitivity analysis of the response of the hydrologic system to changes in temperature, precipitation, and sea level rise. Precipitation was increased ± 10 percent and temperature was increased by 1.5°C, changes thought to be a reasonable expectation of climate change that might occur in South Florida (Figure 6-5). The simulations suggest that decreases in precipitation coupled with increases in evapotranspiration would increase water shortages for urban areas by 27 percent, and the Minimum Flow Levels (MFLs) set to help protect environmentally sensitive areas would be violated more fre-

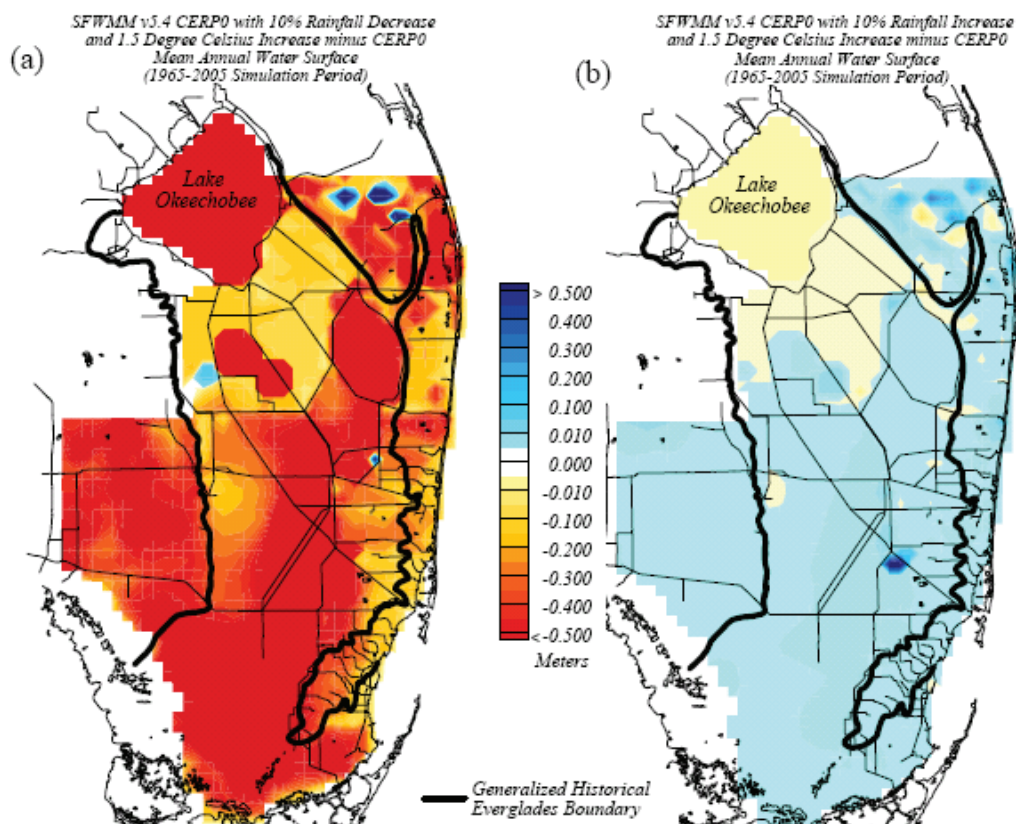

FIGURE 6-5 Simulation results using the South Florida Water Management Model showing average annual water surface elevation difference for the CERP project with modified rainfall and evapotranspiration: (a) -10 percent precipitation and +1.5°C and (b) +10 percent precipitation and +1.5°C, minus the CERP project base run (i.e., no change in precipitation and temperature).

SOURCE: Modified from Obeysekera et al. (2010).

quently. The analysis suggests that the system could accommodate a 10 percent increase in precipitation with an increase in temperature, which enhances loss by evapotranspiration.

Analysis of sensitivity to sea level rise suggests that the discharge capacity of control structures will be impaired under modest increases in sea level (Figure 6-6). Most of the control structures will lose half of their discharge capacity with increases in sea level as small as 12 cm. Fifty percent of the control structures

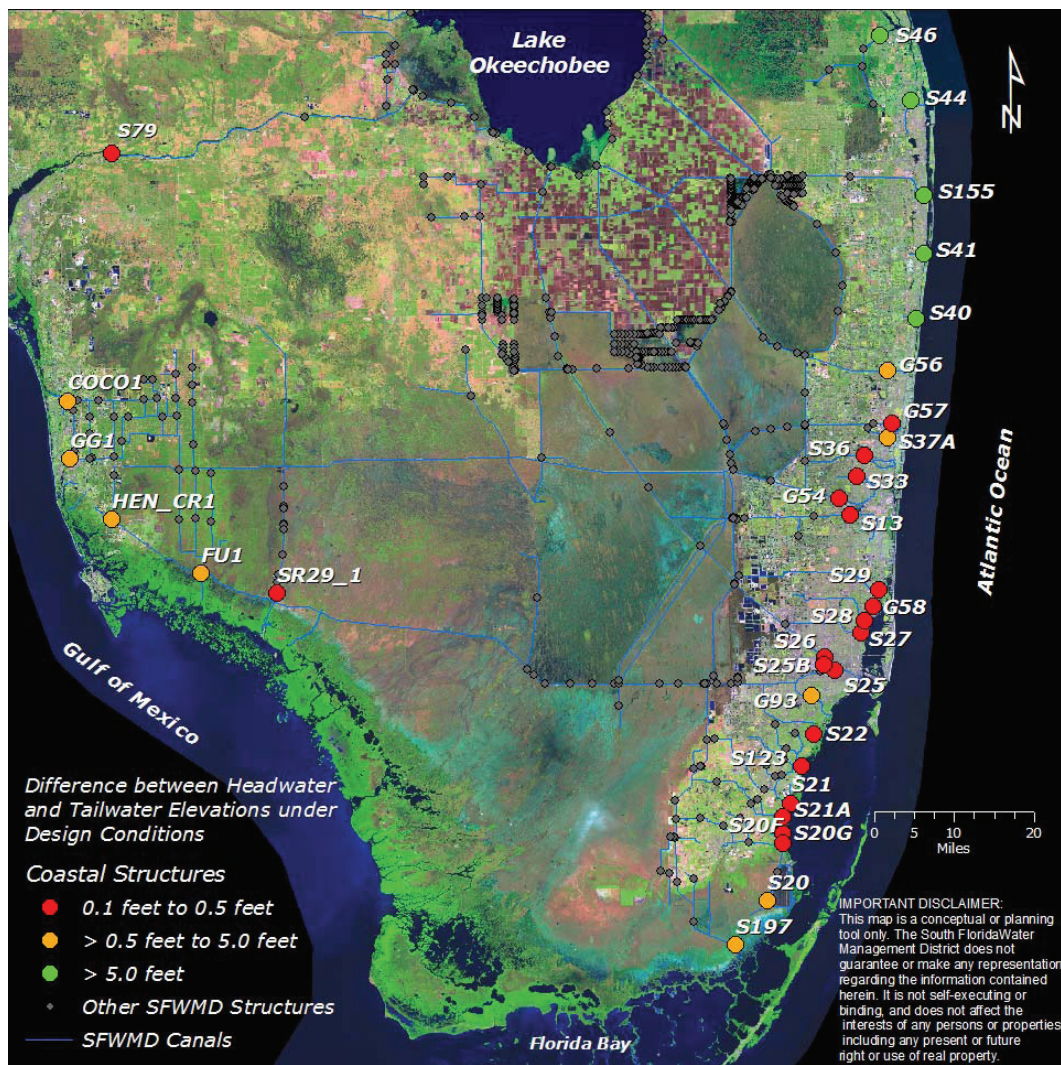

FIGURE 6-6 Vulnerability of coastal structures to potentially rising sea levels. High vulnerability structures are red, medium vulnerability are orange, and low vulnerability are green.

SOURCE: SFWMD (2009a).

will lose their capacity with mean increases in sea level of 0.2 m. To put this in perspective, at current rates of sea level rise, the mean sea level at Key West is expected to increase 0.3 to 0.4 m by 2100. In order to mitigate against salt water intrusion under a sea level rise scenario, the stage of coastal canals would

need to be raised. However, this change in operation would increase the risk of flooding in the urban coastal area (Obeysekera et al., 2010).

Incorporation of Climate Change in CERP Planning. CERP planners are also working to update the CERP Guidance Memorandum related to sea level rise (CGM 16; USACE and SFWMD, 2004b), considering new scientific information and new USACE national guidance on incorporating sea level rise into project planning (USACE, 2009d). The new guidance memorandum is anticipated to be finalized in Fall 2010. Meanwhile, the team is working with CERP project development teams to develop more up-to-date sea level change impact assessments, and the revised guidance memorandum will include case studies of sea level rise assessments in Biscayne Bay Coastal Wetlands and the C-111 Spreader Canal. CERP planners are also working on a report that will provide a preliminary impacts assessment based on sea level change, identify regional- and local-scale modeling needs, and help coordinate related interagency climate change research and data collection efforts. A subsequent effort, planned for completion around 2013, will synthesize available data and assess adaptation strategies (Glenn Landers, USACE, personal communications, 2010).

Assessment of Climate Change Research Progress for CERP. The committee commends the SFWMD researchers on their climate change analyses over the past two years that looked at historical data, identified issues with GCM predictions, and considered implications of regional model sensitivity analysis to operations. The committee also commends the CERP efforts to incorporate the most recent information on sea level rise projections into CERP planning. The committee encourages continued attention to these important issues and the evolving science. NRC (2008) offered several suggestions for research so that CERP planners could better adapt the program to future conditions, and although this section highlights some of the important progress that has been made since that report was released, more remains to be done. The CERP agencies should engage climate scientists with academic institutions and the NOAA to improve both global and regional circulation model predictions for South Florida at the temporal and spatial scales required for improved water resources planning and management. It is also critical that South Florida climate change and sea level rise research findings and analysis of the potential effects of these changes be integrated with relevant social science research and effectively communicated to restoration and water management decision makers. This is particularly urgent, as the scenario analysis discussed above suggests that increasing conflicts between urban water needs (water supply, flood control) and water needs for restoration may come with climate change. RECOVER or the Science Coordination Group could usefully assist this communication effort through workshops or synthesis papers.

Progress in Geomorphologic Research

The primary physical surface of the Everglades is a mosaic of linear sawgrass ridges separated by deeper water sloughs, together known as ridge and slough topography, with tear-drop shaped tree islands roughly aligned with the ridges and sloughs and scattered throughout the landscape (Figure 6-7; McPherson and Halley, 1996). Under pre-drainage conditions, these landscapes covered about 4,000 square miles of the Florida peninsula south of Lake Okeechobee (Lemark et al., 2006), although they have declined to about half of their former extent. The largest remnant of these landscapes is in Water Conservation Area (WCA)-3A. These physical surfaces provide the foundations for the biological components of the Everglades ecosystem, so that restoration of the Everglades ecosystem depends on understanding their physical components.

Only in the past few years have researchers begun to generate a clear understanding of how the distinctive Everglades landscape was formed and is maintained. Research on the maintenance of ridges, sloughs, and tree islands over the past 10 years has demonstrated a conclusive connection between the nature of the flow of water through the system and the morphology and distribution of the features.

An assessment of the state of scientific knowledge by the Science Coordination Team (SCT, 2003) and a review by the NRC (2003a) concluded that a successful restoration effort required an improvement in knowledge about tree



FIGURE 6-7 Ridge and slough topography in the upper reaches of Shark River Slough, about 1915.

SOURCE: SCT (2003).

island and ridge and slough topography, and the exploration of four high priority issues:

- expand multi-disciplinary understanding of the paleo-environmental history of the Everglades geomorphology to identify drivers of change and to put the present landscape in context;
- create new conceptual models for the formation and maintenance of the landscape features to assist managers of the restoration;
- quantify the spatial and temporal movement of sediment in the system to understand change in the system; and
- quantitatively describe water flow over small increments of time and large areas so that water management decisions can be connected to implications for geomorphic restoration.

Substantial progress has been made in three of the four priorities, as described in the following paragraphs.

Paleo-Environmental History. Researchers have developed paleo-environmental histories of the Everglades landscape and have determined some of the most important drivers for its maintenance. Using pollen data, Bernhardt and Willard (2009) showed that the ridge and slough topography formed primarily during dry climatic periods. The pollen data strongly suggest that the even when water levels varied, sloughs have been consistent in their locations, although they changed in size as the climate varied between wet and dry conditions. Long-term data show that the ridge and slough topography is a product of varying water levels, so that successful restoration efforts will also include variable water depths.

Formation and Maintenance of Landscape Features. Investigators are also creating new models to conceptualize how the tree islands and ridge and slough topography are maintained. The ridges do not appear to be connected with bedrock highs; rather, they are features representing vertical relief in the peat layer alone (Ewe, 2009), although some tree islands occupy bedrock highs with thin peat layers, most commonly in Everglades National Park (Volin et al., 2009). The ridge-slough-tree island topographic pattern is increasingly seen as functionally similar to the patterned peatlands of the boreal regions and as part of a larger set of ecosystems in which the combination of particular plant communities, water depths, and flows and the development of the peat substrate interact in a series of complex feedback processes to create and maintain characteristic landscape patterning (van der Valk and Warner, 2009). Zweig and Kitchens (2008) showed that vegetation plays a role in the maintenance of these landscape features. Ridges, for example, are dominated by sawgrass, while the sloughs are

the locations for water and species such as rushes. When dry conditions occur, sawgrass coverage begins to encroach on slough areas. When wet conditions return, the sawgrass once again is more restricted to the ridges. The adjustment process is slow, with lag times of vegetation changes being as much as four years after the hydrologic adjustments. Drying of sloughs for three or more years is enough to allow invasions of sawgrass, and drowning of the landscape leads to the loss of ridges and islands that is not likely to be easily reversed (Zweig and Kitchens, 2009).

Understanding of the relationships of water depths to both flow regimes and tree species tolerance has benefitted from the development of the EDEN network (Liu et al., 2009), and a comprehensive tree island conceptual model has recently been developed linking water depths, water flows, and biotically driven feedback processes (Givnish et al., 2008). Although the relative importance of different mechanisms are still a matter of debate (Givnish et al., 2008; Wetzel et al., 2008, 2009; Troxler et al., n.d.), there is little doubt that some combination of groundwater flow, evapotranspiration, and bird-mediated guano deposition are involved in building and maintaining these landscape features. Tree islands accumulate and sequester large amounts of phosphorus and nitrogen in the soils that could be released into marsh waters upon degradation of these tree islands. Troxler et al. (n.d.) hypothesized that tree islands control the phosphorus content of the surrounding marsh water, which would have large potential ramifications to water management, if verified.

Sediment Transport Processes in Ridge and Slough Topography. At a finer resolution, sediment transport and storage are the key processes in the origin and maintenance of ridge and slough topography. The primary sediment of interest is floc, aggregations of organic particles that are carried downstream through the sloughs but that settle on the ridges under historical hydrologic conditions (Larsen et al., 2009b). The transport through sloughs is by a series of relatively high flow events that carry the material a short distance, deposit it, and then remobilize it again in a subsequent flow event. Flows that fluctuate to produce 1 to 3 feet variations in depth, for example, may help move sediment from sloughs to tree islands and ridges, while maintenance of dominant flow directions parallel to original alignments are likely to aid in preservation of landscape patterns (Larsen et al., 2009a).

Larsen et al. (2007) have postulated that ridge and slough topography and associated plant communities are generated and maintained via feedbacks between topography, spatial variation in peak flow velocities, and organic sediment production, transport, and deposition. Several field experiments have been conducted in the Everglades to test and refine this model. Harvey et al. (2009) monitored flow velocity, water depth, and wind velocity for three years (includ-

ing the passage of Hurricane Wilma) in a relatively intact area of ridge and slough features in WCA-3A. They found that 86 percent of the total discharge moved through sloughs and also demonstrated the primary importance of infrequent, extreme pulsed flows for sediment transport. Evidence from field and lab studies indicates that flow velocities in excess of 3-5 cm/sec are needed to entrain organic floc. By comparison, observed flows in degraded sections of the ridge and slough system are usually less than 1 cm/sec and only occasionally reach 2 cm/sec (USACE and SFWMD, 2009c). In the modern compartmentalized system, systematic changes in water depth and the lack of flow results in differential infilling of sloughs and degradation of ridges that promotes flattening of the system and increasingly disorganized flow. A quasi-three-dimensional simulation model (RASCAL) that represents the complex feedbacks between system hydrology and ecology suggests that effects of flow are manifested over much longer timescales than those of water depth, and that feedback between topography and flow patterns will make it difficult to restore degraded ridge and slough landscapes to historical conditions (Larsen and Harvey, 2010).

Quantitative Description of Flow over Large Scales. Although researchers have made substantial progress in understanding Everglades geomorphology related to paleo-environmental history, conceptual models, and sediment movements, knowledge about water movement on short timescales over large geographic areas remains limited. Field instrumentation to measure extraordinarily slow flows is now developing, but it has been used only in a few sites. As the Decomp Physical Model (see Chapter 3) proceeds, new understanding of flows and sediment transport at the field scale is likely to be helpful. The SFWMD is also conducting extensive research on the dynamics between flows and landscape pattern in its Loxahatchee Impounded Landscape Assessment (LILA) project.² The project seeks to define hydrologic regimes that sustain an Everglades ridge and slough ecosystem using four 20-acre models simulating ridges, sloughs, and tree islands, each with controllable water levels and flows. This project is likely to produce informative results and will be helpful in connecting science to management because it will indicate useful performance measures.

Assessment of Landscape Research Progress for the CERP. Over the past decade, this research has fundamentally changed the conceptualization of the Everglades system from a set of separate plant communities to an interlinked peat-based system in which flow, very low phosphorus concentration in the surface water, and the different communities are functionally linked to each other in creating

²See http://www.sfwmd.gov/portal/page/portal/PG_GRP_SFWMD_WATERSHED/LILA_-_Loxahatchee_I399?project=1326&ou=440.

the characteristic forms of the landscape. This is a laudable improvement in the scientific understanding of the region, as well as an excellent illustration of the application of basic research to inform management goals. With the River of Grass initiative, these research findings along with enhanced systemwide hydrologic modeling tools can be put to good use, as restoration planners consider the potential benefits and costs of diverting additional water flows to the south (see also Chapter 4).

Strengthening Science for Everglades Restoration

The CERP agencies have among their own personnel and their contractors many talented researchers whose work supports the restoration. The broad acceptance of the scientific products of these investigators depends on peer reviews that should be maintained. These peer reviews should extend beyond in-house reviews of research results to include presentation of results at scientific conferences. Recent budget concerns have limited these activities for state agency staff. Presentation and discussion of Everglades research at science conferences at the national and international levels ensures that Everglades researchers can receive supportive and reflective criticism prior to publication of their results. By attending and presenting research at these conferences, Everglades researchers can also learn lessons from other environmental systems that may be applicable in South Florida. At the more regional level, conferences such as the Greater Everglades Ecosystem Restoration (GEER) meeting on planning, policy, and science promote collaboration and information sharing across a large body of Everglades restoration researchers and decision makers. Thus, CERP agencies should support the attendance of their researchers at local, national, and international conferences.

Research Synthesis

Synthesis is “the process of accumulating, interpreting, and articulating scientific results, thereby converting them to knowledge or information” (NRC, 2003b). Synthesis can be motivated by a desire to understand the fundamental properties of natural systems or to generalize information for purposes of predicting system behavior (Boesch et al., 2000). There is a critical need for science synthesis to minimize technical and scientific disagreements that lead to scientific uncertainties that impede restoration decision making.

Two notable research synthesis efforts are now under way. First, RECOVER is leading a multi-agency effort to document recent developments in scientific understanding related to Everglades restoration through a collection of short white papers called the 2010 Shared Definition of Everglades Restoration. As

with all CERP planning efforts, FACA limits participation in this effort to staff or consultants of RECOVER agencies, except through the public comment process. The document was released in draft for public comment in the spring of 2010 and will continue to be revised during the remainder of the year, after a series of public workshops. The report was not released in time for in-depth review by the committee. RECOVER anticipates that the report will serve as a basis for addressing key dilemmas in Everglades restoration and for updating the restoration goals, targets, and performance measures. Second, the National Park Service's Critical Ecosystem Studies Initiative (CESI; see also NRC, 2003b) is funding a synthesis of science on the freshwater Everglades ecosystem, focused on key restoration science questions with relevance to restoration management. The project, led primarily by academic researchers, will synthesize the recent science around these questions and will outline ecosystem consequences of various restoration options by late 2011. Although there may be some overlap between the two projects, the timing will likely allow the CESI project to build upon the RECOVER report. Both efforts represent important steps toward providing clear scientific guidance to restoration decision makers.

Status of Modeling Efforts in Support of Restoration

In both of its previous reports (NRC, 2007, 2008) the committee emphasized that integrated hydrologic, ecological, and biogeochemistry modeling tools are needed for science to play a fully developed role in CERP decision making and ecosystem management. Despite the considerable uncertainties associated with models of a system as large and complex as the Everglades, spatially explicit models are critically important for integrating available information and for examining implications of alternative restoration designs. Unfortunately, resource limitations have hampered progress in this area.

Hydrologic modeling continues to be the focus of CERP model development efforts and, therefore, the strongest among the array of modeling tools available. Progress on the Natural System Regional Simulation Model (NSRSM) has been steady. The NSRSM has been successfully peer reviewed and is now being used along with several versions of the Natural System Model (NSM) in the River of Grass regional planning efforts (Table 6-1; see also Box 4-1). Prior versions of the NSM, based on a 2-mile by 2-mile grid, have been criticized for failing to adequately simulate historic hydrologic characteristics determined from paleoecological data. However, both the NSRSM and the National Park Service-funded modifications to the NSM (called ENP mod1) suggest a much wetter system than previously simulated by the NSM and are more consistent with paleoecological data. The general agreement between the two different

TABLE 6-1 Representative Models Related to CERP Projects

Model Name	Full Name and Main Function
ATLSS	Across Trophic Level System Simulation uses topographic data to convert the 2 × 2 mile landscape of the regional hydrologic models to a 500 × 500 m landscape, to which various ecological models are applied. These range from highly parameterized, mechanistic individual-based models (e.g., EVERKITE, SIMSPAR) to simpler, Habitat Suitability Index (HSI)-type models (SESI, Spatially-Explicit Species Index).
ELM	Everglades Landscape Model is designed to predict the landscape response to different water management scenarios. ELM consists of a set of integrated modules to understand ecosystem dynamics at a regional scale and simulates the biogeochemical processes associated with hydrology, nutrients, soil formation, and vegetation succession. Its main components include hydrology, water quality, soils, periphyton, and vegetation.
NSM	The Natural Systems Model simulates hydro-patterns before canals, levees, dikes, and pumps were built. The NSM mimics frequency, duration, depth, and spatial extent of water inundation under pre-management (i.e., natural) hydrologic conditions. In many cases, those pre-management water levels are used as a target for hydrologic restoration assuming that restoration of the hydrologic response that existed prior to drainage of the system would lead to restoration of natural habitats and biota.
RSM	The Regional Simulation Model is a regional hydrologic model developed principally for application in south Florida. It is a finite-volume-based model capable of simulating multi-dimensional and fully integrated groundwater and surface-water flow. It incorporates two separate simulation engines—the Hydrologic Simulation Engine (HSE) and the Management Simulation Engine (MSE) for water management features to help simplify simulations of proposed operational changes.
RSMWQ	The RSMWQ is a linked-library model that can be selected to run with the RSM. There are two components to simulate water quality; the first is for transport of mobile materials, both soluble and dissolved, and the second is a flexible biogeochemistry module that allows the model user to define the state variables and process equations in the input files.
SFWM	The South Florida Water Management Model simulates hydrology and water systems and is widely accepted as the best available tool for analyzing structural and/or operational changes to the complex water management system in South Florida at the regional scale.
NSRSM	The Natural System Regional Simulation Model, like its predecessor the NSM, simulates the natural system hydrology of South Florida. The use of refined input parameters in combination with the model's improved hydrologic simulation engine result in simulations that reasonably represent pre-drainage (mid-1800) hydrology within an estimated range of performance documented in the best available information sources.

NOTE: The list is not intended to be comprehensive. Numerous other models describe water circulation, water quality, and aspects of system ecology, especially in the estuaries and Lake Okeechobee.

Example Applications	Scale (Spatial Extent; Resolution)	Status	Developers/Sources
Evaluating effects of hydrologic scenarios on biota (habitat and populations of a suite of species)	Regional; 500 × 500 m	Primarily used for research purposes, not for planning or management activities within CERP	http://www.atlss.org/
Support in project planning and ecological research	Regional; 100, 200, 500 m resolution	Version 2.5	SFWMD Fitz and Trimble (2006)
Planning tool for comparing management consequences	Regional; 2 × 2 mile	Version 4.6.2	SFWMD http://www.sfwmd.gov/portal/page/portal/pg_grp_sfwmd_hesm/pg_sfwmd_hesm_nsm?navpage=nsm
Regional long-term (decades) simulation of complex hydrology with management (e.g., southwest Florida)	Regional; Variable grid sizes ranging from 0.1-2 miles	Still under development; Part 1 Peer Review is complete	SFWMD (2005a)
Planning tool for addressing the transport and transformations of chemicals at the regional and subregional scale	Regional; Same as RSM	Still under development	SFWMD, Jawitz et al. (2008)
Regional modeling for EAA Storage Reservoir CERP Project	Regional; 2 × 2 miles square grid	Version 5.5	SFWMD (2005b)
Planning tool for comparing management consequences	Regional; Variable grid sizes ranging from 0.1-2 miles	Version 3.0	SFWMD https://my.sfwmd.gov/portal/page/portal/pg_grp_sfwmd_hesm/portlet_rsm_peerreview/tab2564291/nsrsm_pr_goals_web.pdf

models has strengthened the degree of confidence in the most recent models among scientists and planners.

The South Florida Regional Simulation Model (RSM), still under development, is ultimately intended to replace the South Florida Water Management Model (SFWMM or the “2 × 2”). The RSM includes variable grid sizes ranging from 0.1 to 2 miles on a side, making the model more useful at scales relevant to many ecological parameters. The RSM incorporates two separate simulation engines—the Hydrologic Simulation Engine (HSE) for hydrology and the Management Simulation Engine (MSE) for water management features—which should simplify simulations of proposed operational changes (see NRC, 2008). The RSM has been used successfully on subregional scale projects (e.g., Decomp, C-111, the Biscayne Bay Coastal Wetlands projects), and a link-node version of the RSM, called RSM-Basins has been used in the northern Everglades and is being extended down to the Everglades Agricultural Area (EAA). South of the EAA, a full-mesh version of the RSM has been applied for the Everglades and the lower east coast service area (called the Glades-LECSA model). However, technical issues have prevented the RSM from being applied at the systemwide scale. These issues include problems with convergence between the HSE and MSE, issues with the diffusive wave formulation in steeper areas, and problems in areas where wetting and drying of the land surface occurs. Thus at this time the SFWMM remains the preferred model for regional simulations and is currently being recalibrated with precipitation data through 2005.

Although there remains a long-term goal of including biogeochemical processes within the RSM, little progress has been made toward integrating biogeochemical or sediment transport models with systemwide hydrologic models. A water quality engine for RSM (RSMWQ) was developed by a group from the University of Florida and applied to simulate phosphorus dynamics in WCA-2A. However, continued development of the RSMWQ has been put on hold because of the River of Grass initiative and other modeling priorities, and no integrated regional hydrologic-biogeochemical modeling is being attempted. To date the RSMWQ has not been used by CERP decision makers.

Of additional concern is the apparent step backwards that integrated hydrologic-ecological modeling has taken in CERP planning. The continued development and evaluation of both the Everglades Landscape Model (ELM) and Across Trophic Level System Simulation (ATLSS) model are now undertaken by scientists completely outside of the SFWMD, DOI, USACE, and Interagency Modeling Center (IMC). Both models are now used primarily for research purposes, not for planning or management activities within the CERP. Apparent difficulties in transferring a documented and operational version of ATLSS to the IMC has led to the proposed abandonment of ATLSS as a CERP modeling tool and the proposed development of a new ecological modeling platform by

Everglades National Park. This is a major set-back given the historical investment of resources in the development of ATLSS, the effort required to develop a new modeling platform, and the limited resources available to support the overall CERP modeling effort at the current time. There remains a long-term goal at the SFWMD of incorporating ecological monitoring into the RSM, but this effort is on hold, again due to other modeling priorities. As a result, major CERP efforts such as Decomp and Mod Waters are proceeding without the benefit of integrated hydrologic-water-quality-ecological modeling. As discussed in Chapter 4, improved species-specific modeling tools and multi-species decision analysis tools are also needed to provide more rigorous scientific support for multispecies management options and to understand water management tradeoffs.

In summary, it appears that little progress has been made toward integrated hydrologic, ecological, water quality, and socioeconomic modeling for the CERP in the past five years. SFWMD modelers have been focused on subregional and regional hydrologic modeling efforts, with relatively minor efforts underway to incorporate either water quality or ecologic processes into the RSM. Local-scale modeling of water quality improvement efforts such as stormwater treatment areas (STAs), agricultural best management practices (BMPs), and other ecosystem services provided by private landowners are being conducted by a number of groups, but there are as yet no plans to incorporate these models into regional-scale planning or management. Everglades National Park is undertaking a brand new ecological modeling effort, while independent researchers continue the development and application of ELM and ATLSS. Limited budgetary resources and competition from other modeling efforts (e.g., River of Grass and project-related modeling) appear to be hindering the pace of CERP model development and use in decision making. Lack of investment in the IMC and in model development in general by the federal CERP partners is also hindering progress. As a result near-term prospects of utilizing integrated regional hydrologic-ecological modeling efforts to support CERP design, planning, or management decisions are dim.

ECONOMIC VALUATION OF ECOSYSTEM SERVICES FOR EVERGLADES DECISION MAKING

The concept of ecosystem services³ (Daily, 1997) has been instrumental in ecology for the past decade or more, leading to recent growing interest in the

³Ecosystem services are derived from the physical, biological, and chemical processes in natural ecosystems, which together provide “the conditions and processes through which ecosystems, and the species that make them up, sustain and fulfill human life” (Daily, 1997). Ecosystem services include purification of air and water, nutrient cycling, maintenance of biodiversity, protection from the sun’s ultraviolet rays, flood protection, climate stabilization, and the like.

economic valuation of these services (e.g., Heal, 2000) and their application to decision making. Groups with interests in Everglades restoration increasingly lobby for inclusion of these values in restoration decisions with the intent of influencing the specific restoration activities to be undertaken. As a result, decision makers responsible for guiding Everglades restoration policy face growing pressure to account for economic values of ecosystem services.

A recent NRC report (2005) looked at how economic valuation of ecosystem services could help environmental decision making and concluded that, in general, economic valuation methods are mature and capable of providing useful information in support of improved environmental decision making. However, NRC (2005) also noted that those studies that have the most promise of delivering results that could inform policy decisions are those that focus on the valuation of a single ecosystem service. In more complex examples, knowledge and information may not yet be sufficient to estimate the value of ecosystem services with enough precision to answer policy-relevant questions (NRC, 2005). In this section, the committee provides some background on economic valuation of ecosystem services and then considers to what degree and under what circumstances an effort to estimate the economic value of the ecosystem services provided by the South Florida Ecosystem could inform CERP decision making.

Philosophical and Policy Contexts

Considerations of the role of “ecosystem values” in environmental policy making arise from two philosophical perspectives, intrinsic and anthropocentric. The intrinsic perspective states that nonhuman species have moral interests or rights unto themselves, and therefore, the values of ecosystems and their services are intrinsic and non-anthropocentric. Anthropocentric approaches, which include economic valuation, are based on the philosophical perspective that values arise from the benefits derived by humans. Note that intrinsic value, which underlies the non-anthropocentric perspective, cannot be captured by economic valuation methods. The Everglades’ status as a World Heritage Site and Biosphere Reserve would be consistent with an argument in support of the ecosystem having intrinsic value, but such a value cannot be monetized by traditional methods and thus cannot be captured in a benefit-cost calculation.

Clearly a major factor underlying society’s decision to restore the Everglades was recognition of the importance of the extensive, varied, and valuable ecosystem services provided by this unique ecosystem. In fact, one could argue that these services were so highly valued by society (or difficult to measure) that the decision to restore the Everglades was deemed to be in the public’s interest without typical USACE benefit-cost analyses. Instead, the legal, political, and operational context for Everglades restoration planning is one of cost-effectiveness,

and no formal cost-benefit calculations are required (WRDA 2000). The costs of various project alternatives and their associated improvements to ecological conditions are estimated during the CERP planning process to insure that a reasonable degree of restoration is achieved for the cost (i.e., cost-effectiveness).

Anthropocentric Approaches to Ecosystem Valuation

“The fundamental challenge of valuing ecosystem services lies in providing an explicit description and adequate assessment of the links between the structures and functions of natural systems, the benefits (i.e., goods and services) derived by humanity, and their subsequent values” (NRC, 2005). Economic valuation of ecosystem services relies on successful integration of ecology (i.e., quantification of the ecological structure and functioning) and economics (i.e., application of an economic valuation function). Both elements are complex and challenging in their own right, but the greatest challenge is to insure that the definitions of ecosystem goods and services match across the ecological and economic components (NRC, 2005).

Where an ecosystem’s goods and services can be specified, it is generally possible to assign a value. However, some ecosystem services cannot be valued either because they cannot be adequately measured or because existing valuation methods are inappropriate or unreliable. Numerous taxonomies can be applied to the types and sources of economic value and economic valuation methods. Economic values can arise from the use of an ecosystem service (use values) or from its existence even in the absence of use (non-use value). Use values in turn can be market (e.g., commercial uses such as timber) or non-market (non-commercial uses such as recreation). Most ecosystems will provide an array of ecosystem services, which will require a variety of valuation methods.

There are two fundamental approaches for valuing non-market services: revealed-preference methods and stated-preference methods. Revealed-preference methods⁴ are applicable to use values and are derived from observed human behavior associated with particular uses of the ecosystem (e.g., recreation). Stated-preference methods are survey-based and have wider potential application than do revealed-preference. Non-use values (i.e., ecological and cultural benefits that arise from the existence of the ecosystem rather than from the use of it), for example, can only be attained by stated-preference approaches. As a result of the Everglades’ status as a World Heritage Site and Biosphere Reserve, many people place great value on the existence of a restored ecosystem,

⁴Revealed-preference methods include averting behavior, travel cost, hedonic, dynamic production functions, and general equilibrium modeling of integrated ecological-economic systems. (See NRC [2005] for details.)

even though they may never visit or benefit directly from flood control or water supply (Polasky, 2008). Unfortunately stated-preference valuations generally have less credibility than revealed-preference approaches and have received considerable criticism, leading to a number of efforts to develop “good practice” guidelines including NOAA guidelines (NOAA, 1993).

Benefit transfers and replacement cost and cost of treatment methods have also been used in environmental valuation. Benefit transfer (Boyle and Bergstrom, 1992) is the process of taking an existing value estimate and transferring it to a new location or application that is different from the original one (e.g., applying a per-acre value of a wetland estimated for one site to a second location). Replacement cost and cost of treatment approaches use calculations of the cost of replacing the service or treating the damages arising from the loss of service as a valuation estimate. This approach is not preference-based and is not a measure of economic value.

NRC (2005) cautioned that “replacement cost and cost of treatment methods should be used with great caution if at all,” because the conditions for accurate valuation are rarely satisfied in practice. NRC (2005) specifically recommended against the use of benefit transfer approaches for ecosystem services valuation in most aquatic ecosystem applications. The report stated:

First, with the exception of a few types of applications (e.g., travel-cost and contingent valuation estimates of sportfishing values), there are not a lot of studies that have investigated values of aquatic ecosystem services. Second, most non-market valuation studies have been undertaken by economists in the abstract from specific information that links the resulting estimates of values to specific changes in aquatic ecosystem services and functions. Finally, studies that have investigated the validity of benefit transfers in valuing ecosystem services have demonstrated that this approach is not highly accurate.

Assessment of Economic Valuation of Ecosystem Services in the Everglades Context

The nature and complexity of the Everglades ecosystem poses daunting challenges to any comprehensive ecosystem service valuation effort. A decision to undertake the economic valuation of ecosystem services needs to recognize the critical importance of integrating the ecology (i.e., quantification of the ecological production function) and economics (i.e., application of economic valuation function) and allocate appropriate attention and resources to the valuation effort. NRC (2005) identified three major challenges facing ecosystem services valuation in the Everglades: (1) the hydrologic connectivity between many different ecosystems within the Everglades makes quantifying the restoration-based changes in ecosystem services an extremely complex issue; (2) many of the

important values are linked to existence of species or the existence of the ecosystem itself in something akin to its original condition; these existence values are particularly difficult to value accurately; and (3) aggregation issues can cause problems in comprehensive approaches to ecosystem service valuation, particularly when scaling up the valuation exercise over multiple ecosystems. NRC (2005) concludes that given the hydrologic, ecological, and economic complexities of South Florida, a complete accounting of economic values is unlikely any time in the near future.

Performing a thorough and credible economic valuation of the services of the South Florida ecosystem would be an enormous challenge, and would likely take years. And it would be critical to do it well; any such valuation would need to yield robust and defensible results to be politically persuasive. Prerequisites for such an analysis are integrated hydrologic, ecological, and biogeochemical models to predict ecosystem services likely to result from alternative restoration activities; even then, the analysis would require a large effort. NRC (2005) provides appropriate framework and guidance for any such efforts. CERP planners are specifically cautioned against the use of replacement cost and benefit transfer approaches given the complexities of the Everglades ecosystems.

In summary, credible economic valuation of ecosystem services for Everglades decision making is currently hindered by the complexity of the ecosystem; gaps in data, modeling tools, and valuation techniques; challenges in accounting for existence values; and the likely time required to overcome these concerns. Therefore, the committee concludes that a comprehensive evaluation of ecosystem services is probably not a high priority for CERP planning in the near or medium term. The committee does support the development of an improved understanding of the ecosystem services provided by the South Florida ecosystem, and restoration planners should look for opportunities where the economic valuation of ecosystem services could be useful and should improve the methods of economic valuation of ecosystem services that have the most promising application to the Everglades restoration.

CONCLUSIONS AND RECOMMENDATIONS

The CERP has laid the foundations for adaptive management of Everglades restoration and should now put theory into practice. To do so will require stronger institutional mechanisms for obtaining scientific feedback to planning, management, and implementation decisions. Project planning should explicitly provide for adaptive management in the context of both project-specific and systemwide performance monitoring and evaluation. To ensure stronger coupling of engineering design and operations with ecosystem assessment, project monitoring should be well integrated with systemwide monitoring and assessment.

The effectiveness of the linkages between science and decision making should be examined by CERP leadership. Linking science with policy and management decisions is critically important to achieving restoration goals, but the effectiveness of current mechanisms in providing such linkage has been questioned by some in the restoration community. The committee encourages CERP leadership to examine this issue and to consider mechanisms to improve the communication of relevant scientific findings to decision makers. The committee also recommends greater clarity and transparency in the integration of science into CERP policy and management decisions.

Constructive stakeholder engagement and interagency coordination are key elements of CERP adaptive management. To improve its stakeholder engagement, the USACE and SFWMD should formally evaluate and strengthen the CERP's efforts at outreach and public engagement and implement a process to monitor the efforts' effectiveness and ensure iterative improvement.

Progress continues on improving the Monitoring and Assessment Plan and on building a baseline of monitoring data by which restoration progress will be judged. MAP 2009 largely addressed the prior committee's concerns about monitoring and assessment (NRC, 2008), although a full evaluation of the MAP cannot take place until additional on-the-ground restoration progress has taken place. RECOVER, however, should continue to make use of existing analytic tools (and develop new ones as needed) to establish critical thresholds for performance measure values to support assessment and evaluation. These thresholds should be used as indicators of impending changes in ecosystem components that are important or difficult to reverse, thus potentially allowing corrective measures to be initiated. The Science Coordination Group, working with RECOVER scientists, developed a stoplight indicator system that substantially improves the communication of ecosystem status to the public.

Research efforts are providing a sound basis for critical CERP decision making. Research during the past few years has led to notable advances in our understanding of climate trends in South Florida and the sensitivity of the regional water management system to changes in climate and sea level. Research has also improved understanding of the pre-drainage Everglades and has clarified the key parameters governing the formation and maintenance of landscape features in the ridge and slough ecosystem. For example, the LILA Project is providing critical fundamental understanding of the hydrologic regimes necessary to sustain the Everglades Landscape. Also under way are two major science synthesis efforts directed toward answering key restoration science questions relevant to restoration management.

Little recent progress has been made in developing integrated hydrologic, ecological, and biogeochemical models to inform restoration decision making and to provide input for adaptive management. Hydrologic modeling has been

the primary focus of CERP model development efforts, and substantial progress has been made on the NSRSM and in subregional applications of the RSM. In contrast, efforts to develop ecological models, linked ecological-hydrologic models, and biogeochemical or sediment transport models are notably minimal. As a result, project planning and decision making proceeds without complete information as to the ecological and water quality impacts at both a project and regional scale.

Although the concept of economic valuation of ecosystem services is a promising and important one, the committee does not see near-term benefits to its use in the CERP. Developing accurate and defensible estimates of the economic values of ecosystem services in the Everglades will require careful, deliberate, original research and analysis that integrates assessments of aquatic ecosystem functions, services, and individual value estimates. Prerequisites for such an analysis are integrated hydrologic, ecological, and biogeochemical models that can predict the ecosystem services that will likely result from alternative restoration activities; even with such models, the analysis would require a large effort. For this reason, economic valuation of ecosystem services is unlikely to assist near-term decision making. Everglades restoration planners should be alert to specific opportunities when the economic valuation of ecosystem services has the potential to be useful, and, especially, to improve the methods for economic valuation of ecosystem services and adapt them to the Everglades.

References

- Abtew, W., C. Pathak, R. S. Huebner, and V. Ciuca. 2009. Hydrology of the South Florida environment. In SFWMD, 2009. South Florida Environmental Report. Available online at http://www.sfwmd.gov/portal/page/portal/pg_grp_sfwmd_sfer/pg_sfwmd_sfer_home. Accessed June 18, 2010.
- Abtew, W., C. Pathak, R. S. Huebner, and V. Ciuca. 2010. Hydrology of the South Florida environment. In SFWMD, 2010. South Florida Environmental Report. Available online at http://www.sfwmd.gov/portal/page/portal/pg_grp_sfwmd_sfer/pg_sfwmd_sfer_home. Accessed June 18, 2010.
- Ad Hoc Senior Scientists. 2007. Draft Recommendations and Conclusions from an Ad-hoc Senior Scientist Workshop on Comprehensive Everglades Restoration Plan (CERP) "Restoration Priorities." September 14, 2007. Miami, FL: Florida Atlantic University.
- Ahn, H., and R. T. James. 2001. Variability, uncertainty, and sensitivity of phosphorus deposition load estimates in South Florida. *Water, Air, & Soil Pollution* 126:37–51.
- Aiken, G., M. Haitzer, J. N. Ryan, and K. Nagy. 2003. Interactions between dissolved organic matter and mercury in the Florida Everglades. *Journal De Physique IV* 107:29–32.
- Ali, A. 2009. Nonlinear multivariate rainfall-stage model for large wetland systems. *Journal of Hydrology* 374(3–4):338–350.
- Appelbaum, S. 2008. South Florida Ecosystem Restoration Integrated Delivery Schedule. Presentation to the South Florida Ecosystem Restoration Task Force. May 21, 2008. Available online at http://www.sfrestore.org/tf/minutes/2008_meetings/21,22may08/3a_IDS%20Presentation%205May08.pdf. Accessed August 13, 2010.
- Armentano, T. V., J. P. Sah, M. S. Ross, D. T. Jones, H. C. Cooley, and C. S. Smith. 2006. Rapid responses of vegetation to hydrological changes in Taylor Slough, Everglades National Park, Florida, USA. *Hydrobiologia* 569:293–309.
- Ault, J. S., S. G. Smith, D. McClellan, N. Zurcher, A. McCreary, N. R. Vaughan, and J. A. Bohnsack. 2008. Aerial Survey of Boater Use in Everglades National Park Marine Waters: Florida Bay and Ten Thousand Islands. Available online at http://www.nps.gov/ever/parkmgmt/upload/ENP%20Boat%20Study%20Final%20Report_low%20res.pdf. Accessed on August 20, 2010.
- Baiser, B., and J. L. Lockwood. 2006. The influence of water level on the breeding success of Cape Sable seaside sparrows (*Ammodramus maritimus mirabilis*): Getting the water right for the recovery of an endangered species in the Everglades. Pp. 47–48 in Lockwood, J. L., B. Baiser, R. Bolton, and M. Davis, eds. Detailed Study of Cape Sable Seaside Sparrow Nest Success and Causes of Nest Failure, 2006 Annual Report. Vero Beach, FL. U.S. Fish and Wildlife Service.
- Bates, A. L., W. H. Orem, J. W. Harvey, and E. C. Spiker. 2002. Tracing sources of sulfur in the Florida Everglades. *Journal of Environmental Quality* 31:287–299.
- Beckage, B., and W. J. Platt. 2003. Predicting severe wildfire years in the Florida Everglades. *Frontiers in Ecology and the Environment* 1(3):235–239.

- Beissinger, S. R. 1986. Demography, environmental uncertainty, and the evolution of mate desertion in the Snail Kite. *Ecology* 67:1445–1459.
- Beissinger, S. R. 1990. Alternative foods of a diet specialist, the Snail Kite. *Auk* 107:327–333.
- Beissinger, S. R. 1995. Modeling extinction in periodic environments: Everglades water levels and Snail Kite population viability. *Ecological Applications* 5:618–631.
- Beissinger, S. R., and J. P. Gibbs. 1993. Are variable environments stochastic? A review of methods to quantify environmental predictability. Pp. 132–146 in Yoshimura, J., and C. W. Clark, eds. *Adaptation in Stochastic Environments*. Lecture Notes on Biomathematics Berlin: Springer-Verlag.
- Benoit, J. M., C. Gilmour, A. Heyes, R. P. Mason, and C. Miller. 2003. Geochemical and biological controls over methylmercury production and degradation in aquatic ecosystems. Pp. 262–297 in Chai, Y., and O. C. Braids, eds., *Biogeochemistry of Environmentally Important Trace Elements*. ACS Symposium Series #835. Washington, DC: American Chemical Society.
- Ben-Haim, Y. 2001. *Information Gap Decision Theory: Decisions Under Severe Uncertainty*. New York: Academic Press.
- Bernhardt, C. E., and D. A. Willard. 2009. Response of the Everglades ridge and slough landscape to climate variability and 20th-century water management. *Ecological Applications* 19(7): 1723–1738.
- Biggs, R., S. R. Carpenter, and W. A. Brock. 2009. Spurious certainty: How ignoring measurement error and environmental heterogeneity may contribute to environmental controversies. *Bioscience* 59:65–76.
- Blake, E. S., E. N. Rappaport, and C. W. Landsea. 2007. *The Deadliest, Costliest and Most Intense United States Hurricanes from 1851 to 2006 (and Other Frequently Requested Hurricane Facts)*. NOAA, Technical Memorandum NWS TPC-5, 43 pp.
- Blake, N. 1980. *Land into Water—Water into Land: A History of Water Management in Florida*. Tallahassee, FL: University Presses of Florida.
- Boesch, D. F. 1999. The role of science in ocean governance. *Ecological Economics* 31:189–198.
- Boesch, D. F. 2006. Scientific requirements for ecosystem-based management in the restoration of Chesapeake Bay and coastal Louisiana. *Ecological Engineering* 26:6–26.
- Boesch, D., J. Burger, C. D'Elia, D. Reed, and D. Scavia. 2000. Scientific synthesis in estuarine management. In Hobbie, J., ed. *Estuarine Science: A Synthetic Approach to Research and Practice*. Washington, DC: Island Press.
- Boissin, D. 2009. *Boundary Organizations: An Efficient Structure for Managing Knowledge in Decision-Making Under Uncertainty*. Paper prepared for presentation at the 113th EAAE Seminar, “The role of knowledge, innovation and human capital in multifunctional agriculture and territorial rural development,” Belgrade, Republic of Serbia, December 9–11, 2009. Available online at http://ideas.repec.org/p/hal/journal/hal-00399565_v1.html.
- Bottcher, A. B., N. B. Pickering, B. M. Jacobson, J. G. Hiscock, and R. T. Hilburn. 1998. *WAM: Watershed Assessment Model for Complex Landscapes*. 1st International Conference of Geospatial Information in Agriculture and Forestry. Orlando, Florida, June 1–3, 1998.
- Bottcher, D. 2003. *Letter Report on Estimation of Best Management Practices and Technologies Phosphorus Reduction Performance and Implementation Costs in the Northern Lake Okeechobee Watershed*. Prepared for the South Florida Water Management District. October 20, 2003.
- Bousquin, S. G., D. H. Anderson, M. D. Cheek, D. J. Colangelo, L. Dirk, J. L. Glenn, B. L. Jones, J. W. Koebel, Jr., J. A. Mossa, and J. Valdes. 2009. *Kissimmee Basin*. Chapter 11 in 2009 South Florida Environmental Report. West Palm Beach: South Florida Water Management District.
- Boyle, K. J., and J. C. Bergstrom. 1992. Benefit transfer studies: Myths, pragmatism and idealism. *Water Resources Research* 28(3):657–663.
- Bransford, J. J., R. D. Bixler, and W. E. Hammitt. 2006. An analysis of attitudes towards the comprehensive Everglades Restoration Plan using market segmentation. Pp. 296–302 in Peden, J. G., and R. M. Schuster, eds. *Proceedings of the 2005 Northeastern Recreation Research Symposium*, 2005 April 10–12, Bolton Landing, NY. Gen. Tech. Rep. NE-341. Newtown Square, PA: U.S. Forest Service, Northeastern Research Station.

- Bridgham, S. D., J. Pastor, J. A. Janssens, C. Chapin, and T. J. Malterer. 1996. Multiple limiting gradients in peatlands: A call for a new paradigm. *Wetlands* 16:45–65.
- Bureau of Economic and Business Research. 2005 (November). Florida Statistical Abstract. University of Florida. Available online at <http://www.bebr.ufl.edu/publications/list>. Accessed August 24, 2010.
- Bureau of Economic and Business Research. 2009 (December). Florida City and County Population, 2000–2009. Available online at <http://www.bebr.ufl.edu/publications/list>. Accessed August 24, 2010.
- Burns and McDonnell. 1994. Everglades Protection Project Conceptual Design. February 15, 1994. Report prepared for the South Florida Water Management District, West Palm Beach, FL.
- Burns and McDonnell. 2003. Everglades Protection Area Tributary Basins Long-Term Plan for Achieving Water Quality Goals. October 2003. Report prepared for the South Florida Water Management District, West Palm Beach, FL.
- Carter, L. 1975. *The Florida Experience: Land and Water Use Policy in a Growth State*. Baltimore, MD: Johns Hopkins Press.
- Cassey, P., J. L. Lockwood, and K. H. Fenn. 2007. Using long-term occupancy information to inform the management of Cape Sable seaside sparrows in the Everglades. *Biological Conservation* 139:139–149.
- Cattau, C., W. M. Kitchens, B. Reichert, A. Bowling, A. Hotaling, C. Zweig, J. Olbert, K. Pias, and J. Martin. 2008. Snail Kite Demography Annual Report 2009. U.S. Geological Survey Florida Cooperative Fish and Wildlife Research Unit. University of Florida.
- Cattau, C., W. M. Kitchens, B. Reichert, J. Olbert, K. Pias, J. Martin, and C. Zweig. 2009. Snail Kite Demography Annual Report 2009. Unpublished report for the U.S. Army Corps of Engineers. Jacksonville, FL: USACE.
- Chen, C. Y., and C. L. Folt. 2005. High plankton biomass reduces mercury biomagnification. *Environmental Science and Technology* 39:115–121.
- Chin, D. A. 2010. The Effectiveness of Spreader Canals in Delivering Water to Everglades National Park. Report prepared for Everglades National Park, Task Agreement No. J5297-09-0053.
- Chuirazzi, K. J. and M. J. Duever. 2010. Appendix 7A-2: Picayune Strand Restoration Project Annual Report in the 2010 South Florida Environmental Report. Available online at https://my.sfwmd.gov/portal/page/portal/pg_grp_sfwmd_sfer/portlet_sfer/tab2236037/2010%20report/v1/appendices/v1_app7A-2.pdf. Accessed August 13, 2010.
- Clark, Q. 2002. MS thesis: Phosphorus retention characteristics of newly accreted soils in treatment wetlands of the Florida Everglades. University of Florida.
- Cooke, G. D., E. B. Welch, A. B. Martin, D. G. Fulmer, J. B. Hyde, and G. D. Schriever. 1993. Effectiveness of Al, Ca, and Fe salts to control the internal loading in shallow and deep lakes. *Hydrobiologia* 253:323–335.
- Cook, M. I., and H. K. Herring, eds. 2007. *South Florida Wading Bird Report*. Volume 13. West Palm Beach, FL: South Florida Water Management District.
- Cook, M. I., and M. Kobza, eds. 2009. *South Florida Wading Bird report*. Volume 15. South Florida Water Management District, West Palm Beach, FL.
- Craft, C. B., and C. J. Richardson. 1993. Peat accretion and N, P, and organic C accumulation in nutrient-enriched and unenriched Everglades peatlands. *Ecological Applications* 3:446–458.
- Cressie, N., C. A. Calder, J. S. Clark, J. M. V. Hoef, and C. K. Wikle. 2009. Accounting for uncertainty in ecological analysis: The strengths and limitations of hierarchical statistical modeling. *Ecological Applications* 19:553–570.
- Curnutt, J. L., A. L. Mayer, T. M. Brooks, L. Manne, O. L. Bass, Jr., D. M. Fleming, M. P. Nott, and S. L. Pimm. 1998. Population dynamics of the endangered Cape Sable seaside-sparrow. *Animal Conservation* 1:11–21.
- Daily, G. C., ed. 1997. *Nature's Services: Societal Dependence on Natural Ecosystems*. Washington, DC: Island Press.
- Darby, P. C., R. E. Bennetts, and H. F. Percival. 2008. Dry down impacts on apple snail (*Pomacea paludosa*) demography: Implications for wetland water management. *Wetlands* 28:204–214.

- Davis, S. M. 1994. Phosphorus inputs and vegetation sensitivity in the Everglades. Pp. 357–378 in Davis, S. M., and J. Ogden, eds. *Everglades: The Ecosystem and Its Restoration*. Boca Raton, FL: St. Lucie Press.
- Davis, S. M., and J. C. Ogden, ed. 1994. *Everglades: The Ecosystem and Its Restoration*. Delray Beach, FL: St. Lucie Press.
- DeBusk, T., F. Dierberg, S. Jackson, and M. C. Gabriel. 2009. Chemical Characteristics of STA-2 Cell 1 Surface Waters and Porewaters. Seminar presented at the Second Annual Workshop on Mercury and Sulfur in South Florida Wetlands held in June 2009.
- Dierberg, F. E., T. A. DeBusk, S. D. Jackson, and M. Gabriel. 2009. Effect of Sulfate Enrichment of STAs and Everglades Marshes on Sediment Phosphorus Release. Seminar presented at the Second Annual Workshop on Mercury and Sulfur in South Florida Wetlands held in June 2009.
- Doering, P. H. 1996. Temporal variability of water quality in the St. Lucie Estuary, South Florida. *Journal of the American Water Resources Association* 32:1293–1306.
- Doering, P. H., and R. H. Chamberlain. 1999. Water quality and source of freshwater discharge to the Caloosahatchee Estuary, Florida. *Journal of the American Water Resource Association* 35: 793–806.
- DOI (Department of the Interior). 2005. Science Plan in Support of Ecosystem Restoration, Preservation, and Protection in South Florida. Available online at <http://sofia.usgs.gov/publications/reports/doi-science-plan/2005-DOI-Science-Plan-final.pdf>. Accessed February 15, 2010.
- DOI and USACE (U.S. Army Corps of Engineers). 2005. Central and Southern Florida Project Comprehensive Everglades Restoration Plan: 2005 Report to Congress. Available online at http://www.evergladesplan.org/pm/program_docscerp_report_congress_2005.cfm.
- Dong, Q. 2006. Pulsing sheetflow and wetland integrity. *Frontiers in Ecology and the Environment* 4:9.
- Doren, R. F., J. H. Richards, and J. C. Volin. 2009a. A conceptual ecological model to facilitate understanding the role of invasive species in large-scale ecosystem restoration. *Environmental Indicators* 9S:S150–S160.
- Doren, R. F., J. C. Trexler, M. Harwell, and G. R. Best. 2009b. Indicators for Everglades Restoration. *Ecological Indicators* 9(Supp. 1).
- Duever, M. J., J. F. Meeder, L. C. Meeder, and J. M. McCollom. 1994. The climate of south Florida and its role in shaping the Everglades Ecosystem. Pp. 225–248 in Davis, S. M., and J. C. Ogden, eds. *Everglades: The Ecosystem and Its Restoration*. Delray Beach, FL: St. Lucie Press.
- Ecological Engineering. 2006. The Everglades Nutrient Removal Project: 27(4):265–267.
- Engstrom, D. R., S. P. Schottler, P. R. Leavitt, and K. E. Havens. 2006. A reevaluation of the cultural eutrophication of Lake Okeechobee using multiproxy sediment records. *Ecological Applications* 16:1194–1206.
- EPA (U.S. Environmental Protection Agency). 1996. South Florida Ecosystem Assessment Interim Report—Monitoring for Adaptive Management: Implications for Ecosystem Restoration. EPA-904-96-008. Washington, DC: EPA. Available online at <http://www.epa.gov/region4/sesd/sfleair.pdf>. Accessed August 13, 2010.
- EPA. 1998. National Strategy for the Development of Regional Nutrient Criteria, Office of Water, EPA-822-R-98-002. Washington, DC: EPA.
- EPA. 2007. National Nutrient Strategy. Washington, DC: EPA. Available online at <http://www.epa.gov/waterscience/criteria/nutrient/strategy/index.html#problem>. Accessed August 13, 2010.
- EPA. 2008a. Final Total Maximum Daily Load (TMDL) for Biochemical Oxygen Demand, Dissolved Oxygen, and Nutrients in the Lake Okeechobee Tributaries. Atlanta, GA: EPA.
- EPA. 2008b. State Adoption of Numeric Nutrient Standards (1998–2008). EPA 821-F-08-007. Washington, DC: EPA.
- EPA. 2010. Technical Support Document for U.S. EPA's Proposed Rule for Numeric Nutrient Criteria for Florida's Inland Surface Fresh Waters. Washington, DC: EPA. Available online at <http://www.epa.gov/waterscience/standards/rules/florida/>. Accessed August 13, 2010.
- Ewe, S. 2009. Vegetation, Soil Nutrient and Microtopography Survey of Living and Ghost Tree Islands in Water Conservation Area 2A (Report 2). West Palm Beach, FL: Ecology and Environment, Inc.

- FDEP (Florida Department of Environmental Protection). 2001. Total Maximum Daily Load for Total Phosphorus, Lake Okeechobee, Florida. Available online at http://www.dep.state.fl.us/water/tmdl/docs/tmdls/final/gp1/Lake_O_TMDL_Final.pdf. Accessed September 20, 2010.
- FDEP. 2009. Florida Numeric Nutrient Criteria: History and Status. Available online at <http://www.dep.state.fl.us/water/wqssp/nutrients/#background>. Accessed on November 4, 2010.
- Federal Register. 2010. Environmental Protection Agency, "Water Quality Standards for the State of Florida's Lakes and Flowing Waters; Proposed Rule," 75(16):4174–4226.
- Federico, A. C. 1982. Water Quality Characteristics of the Lower Kissimmee River Basin. West Palm Beach, FL: South Florida Water Management District.
- Ferriter, A., K. Serbesoff-King, M. Bodle, C. Goodyear, B. Doren, and K. Langeland. 2002. Comprehensive Review of Exotic Species in the EPA. In SFWMD. 2002. 2002 Everglades Consolidated Report. Available online at http://www.sfwmd.gov/portal/page/portal/pg_grp_sfwmd_sfer/portlet_prevreport/2002_ecr/contents.html. Accessed June 18, 2010.
- Ferriter, A., K. Serbesoff-King, M. Bodle, C. Goodyear, B. Doren, and K. Langeland. 2004. Invasive Species and Everglades Restoration. In SFWMD. 2004. South Florida Environmental Report. Available online at https://my.sfwmd.gov/portal/page/portal/pg_grp_sfwmd_sfer/portlet_prevreport/final/index.html. Accessed June 21, 2010.
- Fisher, M. M, K. R. Reddy, and R. T. James. 2001. Long-term changes in the sediment chemistry of large subtropical lake. *Lake and Reservoir Management* 17:217–232.
- Fitz, H. C., and B. Trimble. 2006. Documentation of the Everglades Landscape Model: ELM v2.5. South Florida Water Management District. <http://my.sfwmd.gov/elm> Reviewed by independent expert panel, reported at <http://my.sfwmd.gov/elm>.
- Flaig, E. G., and K. R. Reddy. 1995. Fate of phosphorus in the Lake Okeechobee watershed, Florida, USA: Overview and recommendations. *Ecological Engineering* 5:127–142
- Fling, H., N. Aumen, T. Armentano, and F. Mazzotti. 2009. The Role of Flow in the Everglades Landscape. University of Florida IFAS Extension Circular 1452. Gainesville, FL: University of Florida.
- Frederick, P. C., and M. W. Collopy. 1989. Nesting success of five ciconiiform species in relation to water conditions in the Florida Everglades. *Auk* 106:625–634.
- Frederick, P. C., and J. C. Ogden. 2001. Pulsed breeding of long-legged wading birds and the importance of infrequent severe drought conditions in the Florida Everglades. *Wetlands* 21(4):484–491.
- Gabriel, M. C. 2009. Sulfur Import, Export and Mass Transfer within South Florida Wetlands. Seminar presented at the Second Annual Workshop on Mercury and Sulfur in South Florida Wetlands held in June 2009.
- GAO (Government Accountability Office). 2007. South Florida Ecosystem: Restoration Is Moving Forward but Is Facing Significant Delays, Implementation Challenges, and Rising Costs. GAO-07-520. Washington, DC: GAO.
- Gilmour, C., D. Krabbenhoft, W. Orem, G. Aiken, and E. Roden. 2007. Status Report on ACME Studies on the Control of Hg Methylation and Bioaccumulation in the Everglades. West Palm Beach, FL: South Florida Water Management District.
- Gilmour, C., W. Orem, G. Aiken, and D. Krabbenhoft. 2009. Sulfur Impacts on MeHg: A Summary of ACME Field Data and Experiments. Seminar presented at the Second Annual Workshop on Mercury and Sulfur in South Florida Wetlands held in June 2009.
- Givnish, T. J., J. C. Volin, V. D. Owen, V.C. Volin, J. D. Muss, and P. H. Glaser. 2008. Vegetation differentiation in the patterned landscape of the central Everglades: Importance of local and landscape drivers. *Global Ecology and Biogeography* 17:384–402.
- Glaser, P. H. 1992. Vegetation and water chemistry. Pp. 15–26 in Wright, H. E. J., B. A. Coffin, and N. E. Aaseng, eds. *The Patterned Peatlands of Minnesota*. Minneapolis: University of Minnesota Press.
- Gomez, J., and C. Bedregal. 2009. Implementation strategies for source control programs for watersheds in the northern and southern Everglades. Appendix 4-1 in 2009 South Florida Environmental Report—Volume I. West Palm Beach, FL: South Florida Water Management District.

- Grunwald, M. 2006. *The Swamp: The Everglades, Florida, and the Politics of Paradise*. New York: Simon and Schuster, Inc.
- Gu, B. H., and T. Dreschel. 2008. Effects of plant community and phosphorus loading rate on constructed wetland performance in Florida, USA. *Wetlands* 28:81–91.
- Guentzel, J. L., W. M. Landing, G. A. Gill, and C. D. Pollman. 1998. Mercury and major ions in rainfall, throughfall, and foliage from the Florida Everglades. *Science of the Total Environment* 213:43–51.
- Guentzel, J. L., W. M. Landing, G. A. Gill, and C. D. Pollman. 2001. Processes influencing rainfall deposition of mercury in Florida. *Environmental Science and Technology* 35:863–873.
- Gunderson, L., and S. S. Light. 2006. Adaptive management and adaptive governance in the everglades ecosystem. *Policy Science* 39:323–334.
- Guston, D. H. 2001. Boundary organizations in environmental policy and science: An introduction. *Science, Technology, and Human Values* 26(4):399–408.
- Harvey, J. W., and P. V. McCormick. 2009. Groundwater's significance to changing hydrology, water chemistry, and biological communities of a floodplain ecosystem, Everglades, South Florida, USA. *Hydrogeology Journal* (2009)17:185–201.
- Harvey, J. W., J. E. Saiers, and J. T. Newlin. 2005. Solute transport and storage mechanisms in wetlands of the Everglades, South Florida. *Water Resources Research* 41.
- Harvey, J. W., R. W. Schaffranek, G. B. Noe, L. G. Larsen, D. J. Nowacki, and B. L. O'Connor. 2009. Hydroecological factors governing surface water flow on a low-gradient floodplain. *Water Resources Research* 45.
- Harwell, M., D. Surratt, D. Barone, and N. Aumen. 2008. Conductivity as a tracer of agricultural and urban runoff to delineate water quality impacts in the northern Everglades. *Environmental Monitoring and Assessment* 147:445–462.
- Heal, G. 2000. Valuing ecosystem services. *Ecosystems* 3:24–30.
- Heisler, L., and G. Ehlinger. 2009. Role of Recover and Overview of Recent Recover Products. Presentation to the Committee on Independent Scientific Review of the Everglades Restoration Progress, December 3, 2009, Jacksonville, FL.
- Hine, D., and J. W. Hall. 2010. Information gap analysis of flood model uncertainties and regional frequency analysis. *Water Resources Research* 46. Article W01514.
- Hipel, K. W., and Y. Ben-Haim. 1999. Decision making in an uncertain world: Information-gap modeling in water resources management. *IEEE Transactions on Systems Man and Cybernetics Part C-Applications and Reviews* 29:506–517.
- Ho, D. T., V. C. Engel, E. A. Variano, P. J. Schmieder, and M. E. Condon. 2009. Tracer studies of sheet flow in the Florida Everglades. *Geophysical Research Letters* 36. Available online at http://my.sfwmd.gov/portal/page/portal/xrepository/sfwmd_repository_pdf/nr_2009_0922_fy2010_budget.pdf. Accessed on August 12, 2010.
- Hobbs, R. J., and D. A. Norton. 1996. Towards a conceptual framework for restoration ecology. *Restoration Ecology* 4:93–110.
- Jawitz, J. W., R. Muñoz-Carpena, S. Muller, K. A. Grace, and A. I. James. 2008. Development, Testing, and Sensitivity and Uncertainty Analyses of a Transport and Reaction Simulation Engine (TaRSE) for Spatially Distributed Modeling of Phosphorus in South Florida Peat Marsh Wetlands. U.S. Geological Survey Scientific Investigations Report 2008–5029, 109 pp.
- Johnson, R. 2009. Hydrologic Targets for Everglades Restoration. Presentation at River of Grass, January 15, 2009, Science Workshop. Available online at https://my.sfwmd.gov/portal/page/portal/pg_grp_sfwmd_koe/pg_sfwmd_koe_riverofgrass_workshops. Accessed June 21, 2010.
- Jones, B. L., B. Anderson, D. H. Anderson, S. G. Bousquin, C. Carlson, M. D. Cheek, D. J. Colangelo, and L. Spencer. 2010. Kissimmee Basin. Chapter 11 in 2010 South Florida Environmental Report. West Palm Beach: South Florida Water Management District.
- Jones, L. A. 1948. Soils, Geology, and Water Control in the Everglades Region. Bulletin 442. Gainesville, FL: University of Florida Agricultural Experiment Station.
- Juston, J., and T. A. DeBusk. 2006. Phosphorus mass load and outflow concentration relationships in stormwater treatment areas for Everglades restoration. *Ecological Engineering* 26:206–223.

- Kadlec, R. H., 1994. Detention and mixing in free water wetlands. *Ecological Engineering* 3:345–380.
- Kadlec, R. H, and S. D. Wallace. 2009. *Treatment Wetlands*, 2nd edition. Boca Raton, FL: CRC Press.
- Kiker, C. F., J. W. Milon, and A. W. Hodges. 2001. Adaptive learning for Science based policy: The Everglades Restoration. *Ecological Economics* 37:403–416.
- Kimball, D., and K. Whisenant. 2008. Everglades National Park and Dry Tortugas National Park: Superintendents' Report, Fiscal Year 2008. Available online at <http://www.nps.gov/ever/parkmgmt/upload/2008%20DRTO%20EVER%20Final%20Supt%20Annual%20Report.pdf>. Accessed May 28, 2010.
- Kleeberg, A., and J. G. Kohl. 1999. Assessment of the long-term effectiveness of sediment dredging to reduce benthic phosphorus release in shallow Lake Muggelsee (Germany). *Hydrobiologia* 394:153–161.
- Krabbenhoft, D., W. Orem, G. Aiken, and C. Gilmour. 2009. Linking Mercury, Sulfate, DOC and Hydrology at Site 3A15 1995–2008. Seminar presented at the Second Annual Workshop on Mercury and Sulfur in South Florida Wetlands held in June 2009.
- Kushlan, J. A. 1987. External threats and internal management: The hydrologic regulation of the Everglades, Florida, USA. *Environmental Management* 11:109–119.
- Kushlan, J. A., G. Morales, and P. C. Frohring. 1985. Foraging niche relations of wading birds in tropical wet savannas. Pp. 663–682 in Buckley, P. A., M. S. Foster, R. S. Ridgely, and F. G. Buckley, eds. *Neotropical Ornithology*, Ornithological Monograph No. 36.
- Lach, D., P. List, B. Steel, and B. Shindler. 2003. Advocacy and credibility of ecological scientists in resource decision making: A regional study. *BioScience* 53:170–178.
- Lal, A. M. W., R. Van Zee, and M. Belnap. 2005. Case study: Model to simulate regional flow in South Florida. *Journal of Hydrologic Engineering* 131:247–258.
- Lamars, L. P. M., H. B. M. Tomassen, and J. G. M. Roelofs. 1998. Sulfate-induced eutrophication and phytotoxicity in freshwater wetlands. *Environmental Science and Technology* 32:199–205.
- Landing, W. M., J. J. Perry, J. L. Guentzel, G. A. Gill, and C. D. Pollman. 1995. Relationships between the atmospheric deposition of trace-elements, major ions, and mercury in Florida—the Fams Project (1992–1993). *Water, Air, and Soil Pollution* 80:343–352.
- Larsen, L. G., and J. W. Harvey. 2010. Modeling of hydroecological feedbacks predicts distinct classes of landscape pattern, process, and restoration potential in shallow aquatic ecosystems. *Geomorphology* 126(3–4):279–296.
- Larsen, L. G., J. W. Harvey, and J. P. Crimaldi. 2007. A delicate balance: Ecohydrological feedbacks governing landscape morphology in a lotic peatland. *Ecological Monographs* 77:591–614.
- Larsen, L. G., J. W. Harvey, and J. P. Crimaldi. 2009a. Morphologic and transport properties of natural organic floc. *Water Resources Research* 45: W01410, doi:10.1029/2008WR006990.
- Larsen, L. G., J. W. Harvey, G. B. Noe, and J. P. Crimaldi. 2009b. Predicting organic floc transport dynamics in shallow aquatic ecosystems: Insights from the field, the laboratory, and numerical modeling. *Water Resources Research* 45:W01411, doi:10.1029/2008WR007221.
- Lemark, L., A. Croft, D. Childers, S. Mitchell-Bruker, H. Solo-Gabriel, and M. Ross. 2006. Characteristics of surface-water flows in the ridge and slough landscape of Everglades National Park: Implications for particulate transport. *Hydrobiologia* 569:5–22.
- Li, S., I. A. Mendelsohn, H. Chen, and W. H. Orem. 2009. Does sulfate enrichment promote the expansion of *Typha domingensis* (cattail) in the Florida Everglades? *Freshwater Biology* 54(9):1909–1923.
- Light, A. R. 2006. Tales of the Tamiami Trail: Implementing adaptive management in Everglades restoration. *Journal of Land Use* 22:59–99.
- Light, S. S., and J. W. Dineen. 1994. Water control in the Everglades: A historical perspective. Pp. 47–84 in Davis, S. M., and J. C. Ogden, eds. *Everglades: The Ecosystem and Its Restoration*. Boca Raton, FL: St. Lucie Press.
- Lightbody, A. F., M. E. Avenier, and H. M. Nepf. 2008. Observations of short-circuiting flow paths within a free-surface wetland in Augusta, Georgia, U.S.A. *Limnology and Oceanography* 53:1040–1053.

- Liu, Z., J. C. Volin, V. D. Owen, L. G. Pearlstine, J. R. Allen, F. J. Mazzotti, and Aaron L. Hilger. 2009. Validation and ecosystem applications of the EDEN water-surface model for the Florida Everglades. *Ecohydrology* 2:182–194.
- Lockwood, J. L., M. S. Ross, and J. P. Sah. 2003. Smoke on the water: The interplay of fire and water flow on Everglades restoration. *Frontiers in Ecology and the Environment* 462–468. doi:10.1890/1540-9295(2003)001[0462:SOTWTI]2.0.CO;2.
- Lockwood, J. L., D. A. LaPuma, B. Baiser, M. Boulton, and M. J. Davis. 2006. Detailed Study of Cape Sable Seaside Sparrow Nest Success and Causes of Nest Failure. 2006 Annual Report. Vero Beach, FL: U.S. Fish and Wildlife Service.
- Lodge, T. E., 2005. *The Everglades Handbook: Understanding the Ecosystem*. 2nd edition. Boca Raton, FL: CRC Press.
- LoSchiavo, A. 2009. Progress on Establishing and Implementing Adaptive Management for CERP. Presentation to the Committee on Independent Scientific Review of the Everglades Restoration Project, December 2009, Jacksonville, FL.
- Loucks, D. P. 2006. Modeling and managing the interactions between hydrology, ecology and economics. *Journal of Hydrology* 328:408–416.
- MacDonald-Beyers, K., and R. F. Labisky. 2005. Influence of flood waters on survival, reproduction, and habitat use of white-tailed deer in the Florida Everglades. *Wetlands* 25:659–666.
- Marshall, C., Jr., R. Pielke Sr., L. Steyaert, and D. Willard. 2004. The impact of anthropogenic land cover change on the Florida peninsula sea breezes and warm season sensible weather. *Monthly Weather Review* 132:28–52.
- Martin, J., W. Kitchens, C. Cattau, A. Bowling, S. Stocco, E. Powers, C. Zweig, A. Hotaling, Z. Welch, H. Waddle, and A. Paredes. 2007. Snail Kite Demography Annual Progress Report 2006. Florida Cooperative Fish and Wildlife Research Unit and University of Florida, Gainesville.
- Martin, J., W. M. Kitchens, C. E. Cattau, and M. K. Oli. 2008. Relative importance of natural disturbances and habitat degradation on snail kite population dynamics. *Endangered Species Research* 6:25–39.
- Mazzotti F. J., G. R. Best, L. A. Brandt, M. S. Cherkiss, B. M. Jeffery, and K. G. Rice. 2009. Alligators and crocodiles as indicators for restoration of Everglades ecosystems. *Ecological Indicators* 9s:s137–s149.
- McCormick, P. R., T. James, and J. Zhang. 2010. Lake Okeechobee Protection Program—state of the lake and watershed. Chapter 10 in SFWMD. 2010. South Florida Environmental Report. Available online at http://www.sfwmd.gov/portal/page/portal/pg_grp_sfwmd_sfer/pg_sfwmd_sfer_home. Accessed June 18, 2010.
- McCormick, P. V., S. Newman, S. Miao, R. Reddy, D. Gawlik, C. Fitz, T. Fontaine, and D. Marley. 1999. Ecological needs of the Everglades. In Chapter 3 in Redfield, G., ed. 1999 Everglades Interim Report. West Palm Beach, FL: South Florida Water Management District.
- McKelvin, M. R., D. D. Hook, and A. Rozelle. 1998. Adaptation of plants to flooding and soil waterlogging. In Messina, M. G., and W. H. Conner, eds. *Southern Forested Wetlands*. Boca Raton, FL: Lewis Publishers.
- McPherson, B. F., and R. Halley. 1996. *The South Florida Environment: A Region Under Stress*. USGS Circular 1134. Washington, DC: U.S. GPO.
- Mirecki, J. E. 2004. Water-Quality Changes During Cycle Tests at Aquifer Storage Recovery (ASR) Systems of South Florida. U.S. Army Corps of Engineers Engineer Research and Development Center Environmental Lab Report ERDC/EL TR-04-08. Vicksburg, MS.
- Mirecki, J. E. 2010. Technical Opportunities and Challenges for Aquifer Storage and Recovery Implementation. Meeting abstract, 2010 NGWA Ground Water Summit, April 14, Denver, CO.
- Mooij, W. M., R. E. Bennetts, W. S. Kitchens, and D. L. DeAngelis. 2002. Exploring the effect of drought extent and interval on the Florida snail kite: Interplay between spatial and temporal scales. *Ecological Modeling* 149:25–29.

- Morgan, K. T., J. M. McCray, R. W. Rice, R. A. Gilbert, and L. E. Baucum. 2009. Review of Current Sugarcane Fertilizer Recommendations: A Report from the UF/IFAS Sugarcane Fertilized Standards Task Force. University of Florida, Institute of Food and Agricultural Sciences. Report Number SL-295.
- Morgan, M. G., and M. Henrion. 1990. *Uncertainty: A Guide to Dealing with Uncertainty in Quantitative Risk and Policy Analysis*. Cambridge, UK: Cambridge University Press.
- NADP (National Atmospheric Deposition Program). 2009. About NADP. Available online at <http://nadp.sws.uiuc.edu/NADP/>. Accessed April 27, 2010.
- Neidrauer, C. 2009. A New Rainfall-Driven Flow Formula for the Everglades Shark Slough: Can It Be Implemented via the ERT? Presentation to the National Research Council, Committee on Independent Scientific Review of the Everglades Restoration Progress, December 3, 2009, Jacksonville, FL.
- Neidrauer, C., P. Linton, A. Ali, D. Crawford, L. Cadavid, K. Tarboton, and J. Obeysekera. 2007. Projected Performance of the New Rainfall-Based Water Delivery Plan for the Everglades Shark Slough. Proceedings, World Environmental and Water Resources Congress 2007: Restoring Our Natural Habitat, ASCE. 10 pp.
- NOAA (National Oceanic and Atmospheric Administration) Panel on Contingent Valuation. 1993. Natural Resource Damage Assessment Under the Oil Pollution Act of 1990. Federal Register 58(10):4601–4614.
- NOAA. 2010. Sea Level Variations of the United States, 1854–2006. Technical Report NOS CO-OPS 053. Accessible online at http://tidesandcurrents.noaa.gov/publications/Tech_rpt_53.pdf. Accessed September 19, 2010.
- Noe, G., J. W. Harvey, R. W. Schaffranek, and L. G. Larsen. 2010. Controls of suspended sediment concentration, nutrient content, and transport in a subtropical wetland. *Wetlands* 30:39–54.
- Noe, G. B., D. L. Childers, and R. D. Jones. 2001. Phosphorus biogeochemistry and the impact of phosphorus enrichment: Why is the everglades so unique? *Ecosystems* 4:603–624.
- Nott, N. P., O. L. Bass Jr., D. M. Fleming, S. E. Killeffer, N. Fraley, L. Manne, J. L. Curnutt, T. M. Brooks, R. Powell, and S. L. Pimm. 1998. Water levels, rapid vegetational changes, and the endangered Cape Sable seaside sparrow. *Animal Conservation* 1:23–32.
- NRC (National Research Council). 1999. *New Directions for water Resources Planning for the U.S. Army Corps of Engineers*. Washington, DC: National Academy Press.
- NRC. 2001. *Aquifer Storage and Recovery in the Comprehensive Everglades Restoration Plan: A Critique of the Pilot Projects and Related Plans for ASR in the Lake Okeechobee and Western Hillsboro Areas*. Washington, DC: National Academy Press.
- NRC. 2002a. *Regional Issues in Aquifer Storage and Recovery for Everglades Restoration*. Washington, DC: National Academy Press.
- NRC. 2002b. *Florida Bay Research Programs and Their Relation to the Comprehensive Everglades Restoration Plan*. Washington, DC: National Academy Press.
- NRC. 2003a. *Does Water Flow Influence Everglades Landscape Patterns?* Washington, DC: National Academies Press.
- NRC. 2003b. *Adaptive Monitoring and Assessment for the Comprehensive Everglades Restoration Plan*. Washington, DC: National Academies Press.
- NRC. 2003c. *Science and the Greater Everglades Ecosystem Restoration: An Assessment of the Critical Ecosystems Initiative*. Washington, DC: National Academies Press.
- NRC. 2005. *Re-Engineering Water Storage in the Everglades: Risks and Opportunities*. Washington, DC: National Academies Press.
- NRC. 2007. *Progress Toward Restoring the Everglades: The First Biennial Review—2006*. Washington, DC: National Academies Press.
- NRC. 2008. *Progress Toward Restoring the Everglades: The Second Biennial Review—2008*. Washington, DC: National Academies Press.
- Obeysekera, J., J. Browder, and L. Hornung. 1999. The natural South Florida system I. Climate, geology and hydrology. *Urban Ecosystems* 3:223–244.

- Obeyskera, J., M. Irizarry, J. Park, J. Barnes, and T. Dessalegne. 2010. Stochastic Environmental Research and Risk Assessment.
- Odum, H. T. 1953. Dissolved Phosphorus in Florida Waters. Report of Investigations No. 9. Miscellaneous Studies. Tallahassee: Florida Geological Survey.
- Odum, W. E., E. P. Odum, and H. T. Odum. 1995. Nature's pulsing paradigm. *Estuaries* 18:547–555.
- Ogden, J. C., S. M. Davis, K. J. Jacobs, T. Barnes, and H. E. Fling. 2005. The use of conceptual ecological models to guide ecosystem restoration in South Florida. *Wetlands* 25:795–809.
- Parker, G. G., G. E. Ferguson, S. K. Love, et al. 1955. Water resources of southeastern Florida, with special reference to the geology and ground water of the Miami area. Water Supply Paper 1255. Tallahassee, FL: U.S. Geological Survey.
- Patterson, K., and R. Finck. 1999. Tree islands of the WCA-3 aerial photointerpretation and trend analysis project summary report. Geonex Corporation. St. Petersburg, FL: South Florida Water Management District.
- Payette, S., and L. Rochefort. 2001. *Écologie des tourbières du Québec-Labrador*. Quebec, Canada: Les Presses de l'Université Laval.
- Payne, G., and K. Weaver. 2004. Status of phosphorus and nitrogen in the Everglades Protection Area. Chapter 2C in 2004 Everglades Consolidated Report, p. 16. West Palm Beach, FL: South Florida Water Management District.
- Payne, G., T. Bennett, and K. Weaver. 2001. Ecological effects of phosphorus enrichment in the Everglades. Chapter 3 in Redfield, G. ed., 2001 Everglades Consolidated Report. West Palm Beach, FL: South Florida Water Management District.
- Payne, G., T. Bennett, and K. Weaver. 2002. Ecological effects of phosphorus enrichment. Chapter 5 in Redfield, G., ed., 2002 Everglades Consolidated Report. West Palm Beach, FL: South Florida Water Management District.
- Payne, G., K. Weaver, and T. Bennett. 2003. Development of a numeric phosphorus criterion for the Everglades Protection Area. Chapter 5 in Redfield, G., ed., 2003 Everglades Consolidated Report, West Palm Beach, FL: South Florida Water Management District.
- Payne, G., K. Weaver, F. Nearhoof, and Katie Hallas. 2010a. Technical Support Document: Derivation of the Water Quality Based Effluent Limit for Total Phosphorus in Discharges to the Everglades Protection Area. Florida Department of Environmental Protection. Tallahassee, FL. 11 pp.
- Payne, G. G., S. Kui Xue, K. Hallas, and K. C. Weaver. 2010b. Status of water quality in the Everglades Protection area. Chapter 3A in SFWMD. 2010. South Florida Environmental Report. Available online at http://www.sfwmd.gov/portal/page/portal/pg_grp_sfwmd_sfer/pg_sfwmd_sfer_home. Accessed June 18, 2010.
- Perry, W. 2004. Elements of South Florida's Comprehensive Everglades Restoration Plan. *Ecotoxicology* 13:185–193.
- Pescatore, D., and J. Han. 2010. Water year 2009 supplemental evaluations for regulatory source control programs in Everglades construction project basins. Appendix 4-2 in 2010. South Florida Environmental Report. West Palm Beach, FL. Available online at https://my.sfwmd.gov/portal/page/portal/pg_grp_sfwmd_sfer/portlet_sfer/tab2236037/2010%20report/v1/appendices/v1_app4-2.pdf. Accessed August 11, 2010.
- Pickhardt, P. C., C. L. Folt, C. Y. Chen, B. Klauwe, and J. D. Blum. 2002. Algal blooms reduce the uptake of toxic methylmercury in freshwater food webs. *Proceedings of the National Academy of Sciences of the United States of America* 99:4419–4423.
- Pietro, K., R. Bearzotti, G. Germain, and N. Iricanin. 2009. STA performance, compliance and optimization. Chapter 5 in 2009. South Florida Environmental Report—Volume I. West Palm Beach, FL: South Florida Water Management District.
- Pietro, K., G. Germain, R. Bearzotti, and N. Iricanin. 2010. Chapter 5: STA Performance, Compliance and Optimization. South Florida Environmental Report. West Palm Beach, FL: South Florida Water Management District.
- Polasky, S. 2008. Rivers of plans for the River of Grass. In Doyle, M., and C. A. Drew. Large-Scale Ecosystem Restoration: Five Case Studies from the United States. Washington, DC: Island Press.

- Policansky, D. 1998a. Science and decision making in fisheries management. Pp. 57–71 in Pitcher, T., P. J. B. Hart, and D. Pauly, eds. *Reinventing Fisheries Management*. London: Kluwer Academic Publishers.
- Policansky, D. 1998b. Science and decision making for water resources. *Ecological Applications* 8(3):610–618.
- Qian, S. S., and Z. Shen. 2007. Ecological applications of multilevel analysis of variance. *Ecology* 88:2489–2495.
- Raiffa, H. 1968. *Decision Analysis: Introductory Lectures on Choices under Uncertainty*. Reading, MA: Addison-Wesley.
- Rayamajhi, M. B., P. D. Pratt, Ted D. Center, P. W. Tipping, and T. K. Van. 2009. Decline in exotic tree density facilitates increased plant diversity: The experience from *Melaleuca quinquenervia* invaded wetlands. *Wetlands Ecology and Management* 17:455–467.
- RECOVER (Restoration, Coordination, and Verification Program). 2004. CERP Monitoring and Assessment Plan: Part 1, Monitoring and Supporting Research. Available online at http://www.evergladesplan.org/pm/recover/recover_map.aspx. Accessed August 12, 2008.
- RECOVER. 2005a. 2005 Assessment Strategy for the Monitoring and Assessment Plan. West Palm Beach, FL: RECOVER.
- RECOVER. 2005b. The Recover Team's Recommendations for Interim Goals and Interim Targets for the Comprehensive Everglades Restoration Plan. Available online at http://www.evergladesplan.org/pm/recover/recover_docs/igit/igit_mar_2005_report/ig_it_rpt_main_report.pdf. Accessed June 15, 2008.
- RECOVER. 2005c. RECOVER's Initial Comprehensive Everglades Restoration Plan Update Report. Available online at <http://www.evergladesplan.org/pm/recover/icu.aspx>. Accessed September 20, 2010.
- RECOVER. 2006a. Comprehensive Everglades Restoration Plan Adaptive Management Strategy. Available online at http://www.evergladesplan.org/pm/recover/recover_docs/am/rec_am_strategy_brochure.pdf. Accessed June 15, 2008.
- RECOVER. 2006b. System Status Report: Pilot Assessment Reports for the Monitoring and Assessment Modules. West Palm Beach, FL: RECOVER.
- RECOVER. 2006c. Assessing the Response of the Everglades Ecosystem to Implementation of the CERP (MAP II). West Palm Beach, FL: RECOVER.
- RECOVER. 2006d. Monitoring and Assessment Plan (MAP), Part 2 2006 Assessment Strategy for the MAP. Available online at http://www.evergladesplan.org/pm/recover/recover_map_part2.aspx. Accessed June 15, 2008.
- RECOVER. 2007a. Comprehensive Everglades Restoration Plan System-wide Performance Measures. Available online at http://www.evergladesplan.org/pm/recover/eval_team_perf_measures.aspx. Accessed August 13, 2010.
- RECOVER. 2007b. Development and Application of Comprehensive Everglades Restoration Plan System-wide Performance Measures. Available online at http://www.evergladesplan.org/pm/recover/perf_systemwide.aspx. Accessed June 15, 2008.
- RECOVER. 2007c. Final 2007 System Status Report. Available online at http://www.evergladesplan.org/pm/recover/assess_team_ssr_2007.aspx. Accessed August 22, 2008.
- RECOVER. 2008. Greater Everglades Performance Measure: Extreme High and Low Water Levels in Greater Everglades Wetlands. Okeechobee Performance Measure: Vegetation Mosaic. Available online at http://www.evergladesplan.org/pm/recover/recover_docs/et/lo_pm_vegetation-mosaic.pdf. Accessed June 14, 2008.
- RECOVER. 2009. Quality Assurance Systems Requirements (QASR) Manual for the Comprehensive Everglades Restoration Plan. Available online at http://www.evergladesplan.org/pm/program_docs/qasr.aspx. Accessed May 13, 2010.
- RECOVER. 2010a. Draft CERP Adaptive Management Integration Guide (Version 3.2). March 2010. Available online at http://www.evergladesplan.org/pm/pm_docs/adaptive_mgmt/031510_amig_v3-2.pdf. Accessed May 13, 2010.

- RECOVER. 2010b. 2009 Draft System Status Report. Available online at http://www.evergladesplan.org/pm/recover/assess_team_ssr_2009.aspx. Accessed August 13, 2010.
- RECOVER. 2010c. Technical Report on Systemwide Performance of CERP 2015 Band 1 Projects. Available online at http://www.evergladesplan.org/pm/recover/band_1_report.aspx. Accessed September 19, 2010.
- Reddy, K. E., S. Newman, T. Z. Osborne, J. R. White, and C. Fitz. 2010. Legacy phosphorus in the Everglades ecosystem: Implications to management and restoration. *Critical Reviews in Environmental Science Technology* (in review).
- Reddy, K. R., and R. DeLaune. 2008. *Biogeochemistry of Wetlands: Science and Applications*. Boca Raton, FL: CRC Press.
- Reddy, K. R., R. G. Wetzel, and R. Kadlec. 2005. Biogeochemistry of phosphorus in wetlands. In Sims, J. T., and A. N. Sharpley, eds. *Phosphorus: Agriculture and the Environment*. Pp. 263–316. Madison, WI: Soil Science Society of America.
- Regan, H. M., Y. Ben-Haim, B. Langford, W. G. Wilson, P. Lundberg, S. J. Andelman, and M. A. Burgman. 2005. Robust decision-making under severe uncertainty for conservation management. *Ecological Applications* 15:1471–1477.
- Rehage, J. S., and J. C. Trexler. 2006. Assessing the net effect of anthropogenic disturbance on aquatic communities in wetlands: Community structure relative to distance from canals. *Hydrobiologia* 569:359–373.
- Richardson, C. J. 2008. *Everglades Experiments*. New York: Springer.
- Richardson, C. J., and P. Vaithyanathan. 1995. Phosphorus sorption characteristics of Everglades soils along a eutrophication gradient. *Soil Science Society of America Journal* 59:1782–1788.
- Rivero, R. G., S. Grunwald, T. Z. Osborne, K. R. Reddy, and S. Newman. 2007. Characterization of the spatial distribution of soil properties in Water Conservation Area 2A, Everglades, Florida. *Soil Science* 172:149–166.
- Rizzardi, K. W. 2001. Translating science into law: Phosphorus standards in the Everglades. *Journal of Land Use and Environmental Law* 17:149–168.
- Rodgers, L., M. Bodle, and F. Laroche. 2010. Status of Nonindigenous species in the South Florida environment. Chapter 9 in SFWMD. 2010 South Florida Environmental Report. Available online at http://www.sfwmd.gov/portal/page/portal/pg_grp_sfwmd_sfer/pg_sfwmd_sfer_home. Accessed June 18, 2010.
- Said, W., and M. C. Brown. 2010. Natural system regional simulation model v3.3. Implementation, results, and evaluation report, September 2010 (draft). South Florida Water Management District, Hydrologic and Environmental Systems Modeling Dept., West Palm Beach, Florida.
- Saunders, C. J., M. Gao, J. A. Lynch, R. Jaffe, and D. L. Childers. 2006. Using soil profiles of 20 seeds and molecular markers as proxies for sawgrass and wet prairie slough vegetation in 21 Shark Slough, Everglades National Park. *Hydrobiologia* 569:475–492.
- Scarlett, L. 2010. Everglades Restoration: Governance, Science and Decision Making. Presentation to the National Research Council, February 25, 2010.
- Scheidt, D. J., and P. I. Kalla. 2007. Everglades Ecosystem Assessment: Water management, water quality, eutrophication, mercury contamination, soils and habitat. Monitoring for adaptive management: A R-EMAP status report. EPA 904-R-07-001. Atlanta, GA: EPA.
- Schueneman, T. J. 2001. Characterization of sulfur sources in the EAA. *Soil and Crop Science Society of Florida Proceedings* 60:49–52.
- Schmitz, D. C. 2007. Florida's invasive plant research: Historical perspective and the present research program. *Natural Areas Journal* 27(3):251–253.
- SCT (Science Coordination Team). 2003. The Role of Flow in the Everglades Ridge and Slough Landscape. Available online at <http://www.sfrestore.org/sct/docs/>. Accessed November 12, 2009.
- Secretary of Interior. 1994. The Impact of Federal Programs on Wetlands. Report to Congress. Chapter 7: Florida Everglades. Available online at <http://www.doi.gov/oepec/wetlands2/v2ch7.html>. Accessed August 13, 2010.
- SEI (Sustainable Ecosystems Institute). 2007. Everglades Multi-Species Avian Ecology and Restoration Review Final Report, November 2007. Portland, OR: SEI.

- Senarath, S., R. Novoa, J. Niedzialek, S. Nair, F. Khatun, J. Morshed, M. Hellinger and N. Islam. 2008. Glades-LECSA RSM Model (Beta Version) Calibration and Verification. Hydrologic & Environmental Systems Modeling Dept., Project BZ844, South Florida Water Management District, West Palm Beach, FL. 599 pp.
- Senarath, S. U. S., R. J. Novoa, F. Khatun, S. Nair, T. Dessalegne, and V. R. Karri. 2010. Calibration and validation of the Glades-Lower East Coast Service Area hydrologic model. South Florida Water Management District, Hydrologic & Environmental Systems Modeling Dept., West Palm Beach, FL.
- SFERTF (South Florida Ecosystem Restoration Task Force). 2000. Coordinating Success: Strategy for Restoration of the South Florida Ecosystem (July 2000). Available online at http://www.sfrestore.org/documents/work_products/coordinating_success_2000.pdf. Accessed on August 20, 2010.
- SFERTF. 2007. Tracking Success: 2007 Integrated Financial Plan for the South Florida Ecosystem Restoration Task Force. Available online at http://www.sfrestore.org/documents/2007_ifp.pdf. Accessed on August 20, 2010.
- SFERTF. 2008. Plan for Coordinating Science: A Framework for Strategic Coordination. Available online at http://www.sfrestore.org/scg/documents/2008_Final_PCS_approved_at_the_Sept_08_TFmeeting.pdf. Accessed February 15, 2010.
- SFERTF. 2009. Tracking Success; 2009 Integrated Financial Plan for the South Florida Ecosystem Restoration Task Force. Available online at http://www.sfrestore.org/documents/Integrated_Financial_Plan_09.pdf. Accessed August 13, 2010.
- SFNRC (South Florida Natural Resources Center). 2010. Tamiami Trail Modifications: Next Steps Project, Summary of Findings and Draft Environmental Impact Statement.
- SFWMD (South Florida Water Management District). 2000. Lower East Coast Regional Water Supply Plan. May 2000. Available online at http://www.sfwmd.gov/portal/page/portal/xrepository/sfwmd_repository_pdf/lec2000_planningdoc.pdf. Accessed on August 24, 2010.
- SFWMD. 2003. Summary of Evaluation of Alternatives for the Lake Okeechobee Sediment Management Feasibility Study. Final Report to the South Florida Water Management District prepared by Blasland, Bouck, and Lee, Inc., Boca Raton, Fla. Presented at public outreach meeting, January 14, 2003.
- SFWMD. 2005a. S. G. Bousquin, D. H. Anderson, G. W. Williams, and D. J. Colangelo, eds. 1930 Kissimmee River Restoration Studies Volume I—Establishing a Baseline: Pre-restoration 1931 Studies of the Channelized Kissimmee River. Technical Publication ERA #432. South Florida Water Management District, West Palm Beach, FL.
- SFWMD. 2005b. D. H. Anderson, S. G. Bousquin, G. W. Williams, and D. J. Colangelo, eds. 1934 Kissimmee River Restoration Studies Volume II—Defining Success: Expectations for 1935 Restoration of the Kissimmee River. Technical Publication ERA #433. South Florida Water Management District, West Palm Beach, FL.
- SFWMD. 2008. Lake Okeechobee Watershed Construction Project Phase II Technical Plan. West Palm Beach, FL: SFWMD.
- SFWMD. 2009a. South Florida Water Management District, "The Ripple Effect." Available online at https://my.sfwmd.gov/portal/page/portal/common/newsr/enews/ripple/code/pages/ripple_index.html. Accessed August 13, 2010.
- SFWMD. 2009b. Settlement Agreement Report—Third Quarter July–September 2009, prepared by the Technical Oversight Committee. Available online at www.sfwmd.gov/portal/page/portal/pg_grp_sfwmd_era/portlet_archives_meetings_subtabs/tab23692216/sa_rpt_12_08_2009_revised.pdf. Accessed August 13, 2010.
- SFWMD. 2009c. South Florida Water Management District, "2010 SFWMD Budget Reflects Continued Commitment to Ecosystem Restoration." West Palm Beach, FL. Available online at http://www.sfwmd.gov/portal/page/portal/xrepository/sfwmd_repository_pdf/nr_2009_0922_fy2010_budget.pdf. Accessed on November 4, 2010.

- SFWMD. 2009d. Settlement Agreement Report: Second Quarter, April–June 2009, prepared for the Technical Oversight Committee September 17, 2009. Available online at http://my.sfwmd.gov/portal/page/portal/pg_grp_sfwmd_era/portlet_reports/tab1640061/sa_rpt_9_17_2009_final.pdf. Accessed February 12, 2010.
- SFWMD. 2009e. Interdepartmental Climate Change Group, South Florida Water Management District, Draft Climate Change and Water Management in South Florida. West Palm Beach, FL: SFWMD.
- SFWMD. 2010a. Quick Facts on Everglades Restoration Progress. January 2010. Available online at <http://www.sfwmd.gov/portal/pls/portal/docs/15479489.PDF>. Accessed May 6, 2010.
- SFWMD. 2010b. Draft Nutrient Budget Analysis for the Lake Okeechobee Watershed. Water Resources Work Order No. ST61239 WO05. (*reviewed draft report*)
- SFWMD. 2010c. News Release: SFWMD Board Approves Affordable Plan for River of Grass Acquisition. August 12, 2010. West Palm Beach, FL. Available online at http://www.sfwmd.gov/portal/page/portal/xrepository/sfwmd_repository_pdf/nr_2010_0812_rog_ammended_final.pdf. Accessed August 20, 2010.
- SFWMD and FDEP (Florida Department of Environmental Protection). 2008a. South Florida Environmental Report: Volume 1. The South Florida Environment.
- SFWMD and FDEP. 2008b. South Florida Environmental Report: Appendix 3C-2: Summary of Annual Flows and Total Phosphorus Loads by Structure for Water Year 2007. West Palm Beach, FL: South Florida Water Management District.
- Sklar, F., S. Hagerthy, V. Engel, J. Harvey, L. Larsen, K. Legault, S. Newman, G. Noe, J. Redwine, C. Saunders, and J. Trexler. 2009a. The Decomp Physical Model Science Plan. Draft Report Version October 2009. Available online at http://www.evergladesplan.org/pm/projects/project_docs/pdp_12_decomp/060410_decomp_ea_final/april_2010_decomp_ea_app_e_bk.pdf. Accessed June 14, 2010.
- Sklar, F., T. Dreschel, and K. Warren. 2009b. Chapter 6: Ecology of the Everglades Protection Area. In SFWMD, 2009. South Florida Environmental Report. Available online at https://my.sfwmd.gov/portal/page/portal/pg_grp_sfwmd_sfer/portlet_sfer/tab2236041/2009report/report/v1/vol1_table_of_contents.html. Accessed June 21, 2010.
- Sklar, F., T. Dreschel, and K. Warren. 2010. Ecology of the Everglades Protection Area. In SFWMD, 2010. South Florida Environmental Report. Available online at https://my.sfwmd.gov/portal/page/portal/pg_grp_sfwmd_sfer/portlet_sfer/tab2236037/2010%20report/v1/vol1_table_of_contents.html. Accessed June 21, 2010.
- Sklar, F. H., and A. G. van der Valk. 2002. Tree islands of the Everglades: An overview. Pp. 1–17 in Sklar, F. H., and A. G. van der Valk, eds. *Tree Islands of the Everglades*. Dordrecht, The Netherlands: Kluwer Academic Publishers.
- Sklar, F. H., M. J. Chimney, S. Newman, P. McCormick, D. Gawlik, S. L. Miao, C. McVoy, W. Said, J. Newman, C. Coronado, G. Crozier, M. Korvela, and K. Rutchey. 2005. The ecological–societal underpinnings of Everglades restoration. *Frontiers in Ecology and the Environment* 3:161–169.
- Slate, J. E., and R. J. Stevenson. 2000. Recent and abrupt changes in the Florida Everglades indicated by siliceous microfossils. *Wetlands* 20:346–356.
- Smolders, A. J. P., L. P. M. Lamers, E. C. H. E. T. Lucassen, G. Van der Velde, and J. G. M. Roelofs. 2006. Internal eutrophication: How it works and what to do about it—A review. *Chemistry and Ecology* 22:93–111.
- Snyder, N. F. R., and H. A. Snyder. 1969. A comparative study of mollusc predation by Limpkins, Everglade Kites, and Boat-tailed Grackles. *Living Bird* 8:177–223.
- Snyder, N. F. R., S. R. Beissinger, and R. E. Chandler. 1989. Reproduction and demography of the Florida Everglade (Snail) Kite. *Condor* 91:300–316.
- SSG (Science Sub-Group). 1993. Federal Objectives for the South Florida Restoration by the Science Sub-Group of the South Florida Management and Coordination Working Group. Miami, FL.

- Steinman, A. D., K. E. Havens, H. J. Carrick, and R. VanZee. 2002. The past, present, and future hydrology and ecology of Lake Okeechobee and its watersheds. Pp. 19–37 in Porter, J., and K. Porter, eds. *The Everglades, Florida Bay, and Coral Reefs of the Florida Keys. An Ecosystem Handbook*. Boca Raton, FL: CRC Press.
- Stewart-Oaten, A. 1996. Goals in environmental monitoring. Pp. 17–27 in Schmitt, R. J., and C. W. Osenberg, eds. *Detecting Ecological Impacts: Concepts and Applications in Coastal Habitats*. San Diego, CA: Academic Press.
- Stewart-Oaten, A., and J. R. Bence. 2001. Temporal and spatial variation in environmental impact assessment. *Ecological Monographs* 71:305–339.
- Surratt, D. D., M. G. Waldon, M. C. Harwell, and N. G. Aumen. 2008. Time-series and spatial tracking of polluted canal water intrusion into wetlands of a national wildlife refuge in Florida, USA. *Wetlands* 28:176–183.
- Surratt, D. D., T. Osborne, D. Shinde, and N. G. Aumen. 2010. Recent Degradation of the Vegetation Community in Taylor Slough Wetlands (Everglades National Park). Proceedings of GEER 2010: Greater Everglades Ecosystem Restoration Conference. July 12–16, 2010.
- SWET (Soil and Water Engineering Technology), Inc. 2008. Final Report: Nutrient Loading Rates, Reduction Factors and Implementation Costs Associated with BMPs and Technologies. Prepared for the South Florida Water Management District. July 14, 2008.
- Swift, D. R., and R. B. Nicholas. 1987. Periphyton and water quality relationships in the Everglades Water Conservation Areas 1978–1982. Technical Publication 87-2 DRE233. Tallahassee, FL: South Florida Water Management District.
- Sykes, P. W., J. A. Rodgers Jr., and R. E. Bennetts. 1995. Snail kite. *Birds of North America*. 171:1–32.
- Thomas, T. M. 1974. A detailed analysis of climatological and hydrological records of south Florida with reference to man's influence upon ecosystem evolution. Pp. 82–122 in Gleason, P. J., ed. *Environments of South Florida: Present and Past*. Miami, FL: Miami Geological Society.
- Troxler, T., D. Rondeau, O. Sanchez, A. Hines, and R. Travieso. n.d. Final Report for Pilot study to calculate nutrient and hydrological fluxes in a tree island. Southeast Environmental Research Center, Florida International University, Miami, FL.
- USACE (U.S. Army Corps of Engineers). 1996. C&SF Project, USACE Master Water Control Manual for the WCAs, ENP and ENP-SDCS, Volume 4 (June 1996) Sec. 3-02b, p. 3–3.
- USACE. 2002. Final Environmental Impact Statement: Interim Operational Plan (IOP) for Protection of the Cape Sable Seaside Sparrow. Available online at <http://hpm.saj.usace.army.mil/issueweb/Sparrow/fiopeis.htm>. Accessed April 30, 2010.
- USACE. 2004. Picayune Strand Restoration Integrated Project Restoration Report. Available online at http://www.evergladesplan.org/pm/projects/docs_30_sgge_pir_final.aspx. Accessed on August 20, 2010.
- USACE. 2007. Memorandum for Director of Civil Works on Comprehensive Everglades Restoration Plan, Water Quality Improvements. November 30, 2007.
- USACE. 2009a. Integrated Delivery Schedule. November 2, 2009 version. Available online at http://www.evergladesplan.org/pm/progr_int_schedule.aspx. Accessed June 14, 2010.
- USACE. 2009b. C-111 Spreader Canal Western Project: Facts & Information. Available online at http://www.evergladesplan.org/docs/fs_c111_may_2009.pdf. Accessed August 13, 2010.
- USACE. 2009c. Everglades Report: May/June 2009. Available online at http://www.evergladesplan.org/docs/eg_report_may_2009.pdf. Accessed June 24, 2010.
- USACE. 2010a. CERP Adaptive Management Workshop: Incorporating New Information Into CERP Decision-Making. Available online at http://www.evergladesplan.org/pm/public_meetings/MeetingItem.aspx?meetingId=345. Accessed on June 25, 2010.
- USACE. 2010b. Integrated Delivery Schedule Information Leaflet. June 2010. Available online at http://www.sfrestore.org/tf/minutes/2010_meetings/24june10/3b_IDS%20Leaflet%2006-21-2010.pdf. Accessed on August 3, 2010.

- USACE and SFWMD (South Florida Water Management District). 1999. Central and Southern Florida Project Comprehensive Review Study, Final Integrated Feasibility Report and Programmatic Environmental Impact Statement. Available online at http://www.evergladesplan.org/pub/restudy_eis.cfm#mainreport. Accessed August 13, 2010.
- USACE and SFWMD. 2004a. Central and Southern Florida Project Indian River Lagoon—South Final Integrated Project Implementation Report and Environmental Impact Statement.
- USACE and SFWMD. 2004b. CERP Guidance Memorandum 016.00: Sea Level Rise Considerations for Formulation and Evaluation of CERP Projects. Available online at http://www.evergladesplan.org/pm/program_docs/cerp-guidance-memo.aspx. Accessed June 18, 2010.
- USACE and SFWMD. 2005a. Programmatic Regulations: Master Implementation Sequencing Plan 1.0 (April 6, 2005). Available online at http://www.evergladesplan.org/pm/pm_docs/misp/040605misp_report_1.0.pdf.
- USACE and SFWMD. 2005b. Central and Southern Florida Project: Picayune Strand (Formerly Southern Golden Gates Estates Ecosystem Restoration) Final Integrated Project Implementation Report/Environmental Impact Statement. Available online at http://www.evergladesplan.org/pm/projects/docs_30_sgge_pir_final.aspx.
- USACE and SFWMD. 2006. Site 1 Impoundment: Project Final Integrated Project Implementation Report and Environmental Assessment. Available online at <http://publicfiles.dep.state.fl.us/dear/everglades/Site%201%20Impoundment/Tab%20B%20-%20Final%20Site%201%20PIR%20%26%20EA/Main%20Body.pdf>. Accessed August 20, 2010.
- USACE and SFWMD. 2008. Interim Aquifer Storage and Recovery Interim Report 2008. Comprehensive Storage Restoration Plan. Available online at http://www.evergladesplan.org/pm/projects/project_docs/pdp_asr_combined/052808_asr_report/052808_asr_interim_rpt.pdf. Accessed November 4, 2010.
- USACE and SFWMD. 2009a. C-111 Spreader Canal Western Project Draft Project Implementation Report (PIR) and Environmental Impact Statement (EIS). Available online at http://www.evergladesplan.org/pm/projects/docs_29_c111_pir.aspx. Accessed August 13, 2010.
- USACE and SFWMD. 2009b. L-31N (L-30) Seepage Management Pilot Project Final Integrated Pilot Project Design Report Environmental Assessment. Volume 1. June 2009 Revision.
- USACE and SFWMD. 2009c. Central And Southern Florida Project Comprehensive Everglades Restoration Plan C-111 Spreader Canal Design Test Final Design Documentation Report and Final Environmental Assessment. Available online at http://www.evergladesplan.org/pm/projects/project_docs/pdp_29_c11/072909_c111_design_test_final.pdf. Accessed on August 13, 2010.
- USACE and SFWMD. 2010a. Biscayne Bay Coastal Wetlands Phase 1 Draft Integrated Project Implementation Report and Environmental Impact Statement. Available online at http://www.evergladesplan.org/pm/projects/docs_28_biscayne_bay_pir.aspx. Accessed May 3, 2010.
- USACE and SFWMD. 2010b. Reviving the Picayune Strand. January 2010. Available online at http://www.evergladesplan.org/docs/fs_picayune_jan_2010.pdf. Accessed June 14, 2010.
- USACE and SFWMD. 2010c. Installation, Testing and Monitoring of a Physical Model for the Water Conservation Area 3 Decentralization and Sheet Flow Enhancement Project: Final Environmental Assessment and Design Test Documentation Report. April 2010. Available online at http://www.evergladesplan.org/pm/projects/docs_12_wca3_dpm_ea.aspx. Accessed June 14, 2010.
- USACE and SFWMD. 2010d. Biscayne Bay Coastal Wetlands Phase 1 Draft Integrated Project Implementation Report and Environmental Impact Statement. Available online at http://www.evergladesplan.org/pm/projects/docs_28_biscayne_bay_pir.aspx. Accessed May 3, 2010.
- USFWS (U.S. Fish and Wildlife Service). 1996. National Survey of Fishing, Hunting, and Wildlife-Associated Recreation. Available online at <http://wsfrprograms.fws.gov/subpages/NationalSurvey/reports1996.html>. Accessed August 20, 2010.
- USFWS. 2001. National Survey of Fishing, Hunting, and Wildlife-Associated Recreation. Available online at <http://wsfrprograms.fws.gov/subpages/NationalSurvey/reports2001.html>. Accessed August 20, 2010.

- USFWS. 2006. National Survey of Fishing, Hunting, and Wildlife-Associated Recreation. Available online at <http://wsfrprograms.fws.gov/subpages/NationalSurvey/reports2006.html>. Accessed August 20, 2010.
- USFWS. 2007a. West Indian Manatee (*Trichechus manatus*) 5-Year Review: Summary and Evaluation. U.S. Fish and Wildlife Service, Southeast Region, Jacksonville Ecological Services Office, Jacksonville, Florida; Caribbean Field Office, Boquerón, Puerto Rico.
- USFWS. 2007b. Florida Scrub-Jay (*Aphelocoma coerulescens*) 5-Year Review: Summary and Evaluation. U.S. Fish and Wildlife Service, Southeast Region, South Florida Ecological Services Field Office, Vero Beach, Florida.
- USFWS. 2007c. Everglades Snail Kite (*Rhostrhamus sociabilis plumbeus*) 5-Year Review: Summary and Evaluation. U.S. Fish and Wildlife Service, Southeast Region, South Florida Ecological Services Field Office, Vero Beach, Florida.
- USFWS. 2007d. Wood Stork (*Mycteria americana*) 5-Year Review: Summary and Evaluation. U.S. Fish and Wildlife Service Southeast Region South Florida Ecological Services Field Office, Vero Beach, Florida.
- USFWS. 2007e. Crenulate lead-plant (*Amorpha crenulata*) 5-Year Review: Summary and Evaluation. U.S. Fish and Wildlife Service, Southeast Region, South Florida Ecological Services Field Office, Vero Beach, Florida.
- USFWS. 2008a. Eastern Indigo Snake (*Drymarchon couperi*) 5-Year Review: Summary and Evaluation. U.S. Fish and Wildlife Service, Southeast Region, Mississippi Ecological Services Field Office, Jackson, Mississippi.
- USFWS. 2008b. Florida Grasshopper Sparrow (*Ammodramus savannarum floridanus*) 5-Year Review: Summary and Evaluation. U.S. Fish and Wildlife Service, Southeast Region, South Florida Ecological Services Field Office, Vero Beach, Florida.
- USFWS. 2009a. C-111 Spreader Canal, Western Phase 1 Project Miami-Dade County, Florida. Fish and Wildlife Coordination Act Report. South Florida Ecological Services Office. Vero Beach, Florida.
- USFWS. 2009b. Florida Population of the Audubon's Crested Caracara (*Polyborus plancus audubonii*) 5-Year Review: Summary and Evaluation, U.S. Fish and Wildlife Service, Southeast Region, South Florida Ecological Services Field Office, Vero Beach, Florida.
- USFWS. 2009c. Florida Panther (*Puma concolor coryi*) 5-Year Review: Summary and Evaluation. U.S. Fish and Wildlife Service, Southeast Region, South Florida Ecological Services Field Office, Vero Beach, Florida.
- USFWS. 2009d. Okeechobee Gourd (*Cucurbita okeechobeensis* ssp. *okeechobeensis*) 5-Year Review: Summary and Evaluation. U.S. Fish and Wildlife Service, Southeast Region, South Florida Ecological Services Field Office, Vero Beach, Florida.
- USFWS. 2009e. A.R.M. Loxahatchee National Wildlife Refuge Enhanced Water Quality Program 4th Annual Report, July 2009, LOXA09-007. Boynton Beach, FL: USFWS. Available online at http://www.sofia.usgs.gov/lox_monitor_model/reports/4th_annual_09.html. Accessed August 13, 2010.
- Van der Valk, A. G., and B. G. Warner. 2009. The development of patterned mosaic landscapes: An overview. *Plant Ecology* 200:1–7.
- Van Horn, S. and P. Wade. 2010. Chapter 4: Phosphorus Source Controls for the South Florida Environment. 2010 South Florida Environmental Report. West Palm Beach, FL: South Florida Water Management District.
- Van Horn, S., C. Adorasio, C. Bedregal, J. Gomez, S. Gomak, J. Madden, D. Pescatore, S. Sarley, C. Rucks, and P. Wade. 2009. Chapter 4: Phosphorous Source Controls for the South Florida Environment. 2009 South Florida Environmental Report. West Palm Beach, FL: South Florida Water Management Team.
- Variano, E. A., D. T. Ho, V. C. Engel, P. J. Schmieder, and M. C. Reid. 2009. Flow and mixing dynamics in a patterned wetland: Kilometer-scale tracer releases in the Everglades. *Water Resources Research* 45.

- Volin, J. C., D. Owen, C. Coronado-Molina, and F. H. Sklar. 2009. The potential effect of regional-scale hydrological changes to tree island spatial extent and plant species composition in the Florida Everglades, USA: Implications for restoration.
- Walker, W. W. 1995. Design Basis for Everglades Stormwater Treatment Areas. *Water Resources Bulletin* 31:671–685.
- Walker, W. W. 2000. Final Report: Estimation of a Phosphorus TMDL for Lake Okeechobee. Tallahassee, FL: Florida Department of Environmental Protection.
- Walker, W. W. 2005. Evaluation of water quality based effluent limits for measuring compliance with the Everglades phosphorus criterion. Report prepared for the U.S. Department of the Interior.
- WBL (Wetland Biogeochemistry Laboratory). 2009. Comprehensive Analysis and Evaluation of Historical Data and Information for the Stormwater Treatment Areas (STAs). Final Report submitted to the South Florida Water Management District. August 2009. 398 pp.
- Welch, E. B., and G. D. Cooke. 1999. Effectiveness and longevity of phosphorus inactivation with alum. *Lake and Reservoir Management* 15(1):5–27.
- Wetzel, P. R., T. Pinion, D. T. Towles, and L. Heisler. 2008. Landscape analysis of tree island head vegetation in water conservation area 3, Florida Everglades. *Wetlands* 28:276–289.
- Wetzel, P. R., A. G. Van Der Valk, S. Newman, C. A. Coronado, T. G. Troxler-Gann, D. L. Childers, W. H. Orem, and F. H. Sklar. 2009. Heterogeneity of phosphorus distribution in a patterned landscape, the Florida Everglades Plant. *Ecology* 200:83–90.
- Wetzel, R. G. 2001. *Limnology*, 3rd edition. New York: Academic Press.
- White, J. R., K. R. Reddy, and J. Majer-Newman. 2006. Hydrologic and vegetation effects on water column phosphorus in wetland mesocosms. *Soil Science Society of America Journal* 70:1242–1251.
- White, N. J., J. A. Church, and J. M. Gregory. 2005. Coastal and global averaged sea level rise for 1950–2000. *Geophysical Research Letters* 32:L01601, doi:10.1029/2004GL021391.
- White, P. S. 1994. Synthesis: Vegetation pattern and process in the Everglades ecosystem. Pp. 445–458 in Davis, S. M., and J. C. Ogden, eds. *Everglades: The Ecosystem and Its Restoration*. Boca Raton, FL: St. Lucie Press.
- Wilcox, W., and C. McVoy. 2009. Everglades Viewing Windows. Presentation at River of Grass November 17, 2009 Science Workshop. Available online at https://my.sfwmd.gov/portal/page/portal/pg_grp_sfwmd_koe/public_20workshops_20-_20phase_20ii. Accessed June 21, 2010.
- Willard, D. A., L. M. Weimer, and W. L. Riegel. 2001. Pollen assemblages as paleoenvironmental proxies in the Florida Everglades. *Review of Palaeobotany and Palynology* 113:213–235.
- Willard, D. A., C. E. Bernhardt, C. W. Holmes, B. Landacre, and M. Marot. 2006. Response of everglades tree islands to environmental change. *Ecological Monographs* 76:565–583.
- Williams, A. J., and J. C. Trexler. 2006. A preliminary analysis of the correlation of food-web characteristics with hydrology and nutrient gradients in the southern Everglades. *Hydrobiologia* 569:493–504.
- Williams, B., A. Ramsey, and L. Gerry. 2010. Everglades restoration update in the 2010 South Florida Environmental Report. Chapter 7a in SFWMD. 2010. South Florida Environmental Report. West Palm Beach, FL. Available online at https://my.sfwmd.gov/portal/page/portal/pg_grp_sfwmd_sfer/portlet_sfer/tab2236037/2010%20report/v1/vol1_table_of_contents.html. Accessed June 21, 2010.
- Winkler, M. G., P. R. Sanford, and S. W. Kaplan. 2001. Hydrology, vegetation, and climate change in the southern Everglades during the Holocene. *Bulletin of American Paleontology* 361:57–100.
- Wright, A. L., S. Daroub, J. M. McCray, and R. W. Rice. 2008. EAA Sulfur Fertilizer Use and Management. Presented at the First Annual Workshop of Mercury and Sulfur in South Florida Wetlands, February 13, 2008.
- Wu, Y., K. Rutchey, W. Guan, L. Vilchek, and F. H. Sklar. 2002. Spatial simulations of tree islands for Everglades restoration. In Sklar, F. H., and A. van der Valk, eds. *Tree Islands of the Everglades*. Dordrecht, Germany: Kluwer Academic.

- Xue, S. K. 2009. Appendix 3A-5: Summary of Annual Flows and Total Phosphorus Loads by Structure for Water Year 2008. South Florida Environmental Report. West Palm Beach, FL: South Florida Water Management District.
- Xue, S. K. 2010. Appendix 3A-5: Summary of Annual Flows and Total Phosphorus Loads by Structure for Water Year 2009. South Florida Environmental Report. West Palm Beach, FL: South Florida Water Management District.
- Ye, R., A. L. Wright, J. M. McCray, K. R. Reddy, and L. Young. 2009. Sulfur-induced changes in phosphorus distribution in Everglades Agricultural Area soils. *Nutrient Cycling in Agroecosystems*. DOI 10.1007/s10705-009-9319-y.
- Zhang, J., R. T. James, G. Ritter, and B. Sharfstein. 2007. Chapter 10: Lake Okeechobee Protection Program—State of the Lake and Watershed. In 2007 South Florida Environmental Report-Volume I, South Florida Water Management District, West Palm Beach, FL.
- Zhang, J., R. T. James, and P. Mccomick. 2009. Chapter 10: Lake Okeechobee Protection Program-State of the Lake and Watershed. In: 2009 South Florida Environmental Report-Volume I, South Florida Water Management District, West Palm Beach, FL.
- Zweig, C. L., and W. M. Kitchens. 2008. Effects of landscape gradients on wetland vegetation communities: Information for large-scale restoration. *Wetlands* 28(4):1086–1096.
- Zweig, C. L., and W. M. Kitchens. 2009. Multi-state succession in wetlands: A novel use of state and transition models. *Ecology* 90(7):1900–1909.

Acronyms

ARRA	American Recovery and Reinvestment Act
ASR	aquifer storage and recovery
ATLSS	Across Trophic Level System Simulation
BACI	before-after-control-impact
BAPRT	Best Available Phosphorus Reduction Technology
BMP	best management practice
CERP	Comprehensive Everglades Restoration Plan
CISRERP	Committee on Independent Scientific Review of Everglades Restoration Progress
CROGEE	Committee on the Restoration of the Greater Everglades Ecosystem
C&SF	Central and South Florida
CSOP	Combined Structural and Operational Plan
CWA	Clean Water Act
DCT	Design Coordination Team
DMSTA	Dynamic Model for Stormwater Treatment Areas
DO	dissolved oxygen
DOI	U.S. Department of the Interior
DPM	Decomp Physical Model
EAA	Everglades Agricultural Area
E-CISMA	Everglades Cooperative Invasive Species Management Area
ECP	Everglades Construction Project
EIS	Environmental Impact Statement
ELM	Everglades Landscape Model
ENP	Everglades National Park

EPA	Everglades Protection Area; U.S. Environmental Protection Agency
ERTP	Everglades Restoration Transition Plan
FAC	Florida Administrative Code
FDEP	Florida Department of Environmental Protection
FWS	U.S. Fish and Wildlife Service
FY	fiscal year
GAO	Government Accountability Office
GCM	General Circulation Model
GEER	Greater Everglades Ecosystem Restoration
HSE	Hydrologic Simulation Engine
HSI	Habitat Suitability Index
IAR	incremental adaptive restoration
IDS	Integrated Delivery Schedule
IGs	Interim Goals
IMC	Interagency Modeling Center
IOP	Interim Operational Plan
IRL-S	Indian River Lagoon-South
ISOP	Interim Structural and Operational Plan
LILA	Loxahatchee Impoundment Landscape Assessment
LNWR	Loxahatchee National Wildlife Refuge
LOER	Lake Okeechobee and Estuary Recovery
LOPA	Lake Okeechobee Protection Act
LOPP	Lake Okeechobee Protection Plan
MAF	million acre-feet
MAP	monitoring and assessment plan
MFLs	Minimum Flow Levels
MGD	million gallons per day
MISP	Master Implementation Sequencing Plan
MSE	Management Simulation Engine
mt	metric tons
NOAA	National Oceanic and Atmospheric Administration
NPS	National Park Service
NRC	National Research Council

NSM	Natural System Model
NSRSM	Natural System Regional Simulation Model
NWSS	Northwest Shark Slough
O&M	operation and maintenance
PIRs	program implementation reports
ppb	parts per billion
QBEL	quality-based effluent limit
RECOVER	Restoration, Coordination, and Verification
RLG	RECOVER Leadership Group
RSM	Regional Simulation Model
SAC	specific alternative criteria
SAV	submerged aquatic vegetation
SFEER	South Florida Everglades Ecosystem Restoration Program
SFER	South Florida Environmental Report
SFERTF	South Florida Ecosystem Restoration Task Force
SFWMD	South Florida Water Management District
SFWMM	South Florida Water Management Model
STA	stormwater treatment area
SWIM	Surface Water Improvement and Management
TBEL	Technology-Based Effluent Limitation
TMDL	total maximum daily load
TN	total nitrogen
TP	total phosphorus
USACE	U.S. Army Corps of Engineers
USGS	U.S. Geological Survey
WAM	Watershed Assessment Model
WCA	Water Conservation Area
WMA	wildlife management area
WRDA	Water Resources Development Act

Glossary

8.5-square-mile area—The 8.5-square-mile area (SMA) is a low-lying, partially developed area near the northeast corner of Everglades National Park, west of the L-31 north canal. Flood protection was to have been provided under the original 1989 Mod Waters legislation, but years of subsequent study and negotiations with property owners resulted in a compromise in which a flood protection levee is to be built around approximately two-thirds of the 8.5 SMA while providing for purchase of approximately one-third of the private property and 12 homes in the western portion.

Acceler8—An expedited course of action for achieving Everglades restoration. Through Acceler8, the State of Florida intends to implement 11 components of the CERP.

Across Trophic Level System Simulation (ATLSS)—A modeling system that uses topographic data to convert the 2 × 2 mile landscape of the regional hydrological models to a 500 × 500 m landscape to which various ecological models are applied. These range from highly parameterized, mechanistic individual-based models (e.g., EVERKITE, SIMSPAR) to simpler, habitat-suitability models (Spatially-Explicit Species Index and Habitat Suitability Index). The objectives of the ATLSS project are to utilize the outputs of systems models to drive a variety of models that attempt to compare and contrast the relative impacts of alternative hydrologic scenarios on the biotic components of South Florida.

Aquifer storage and recovery (ASR)—A technology for storage of water in a suitable aquifer when excess water is available and for recovery from the same aquifer when the water is needed to meet peak emergency or long-term water demands. Wells are used to pump water in and out of the aquifer.

Best management practices (BMPs)—Effective, practical methods that prevent or reduce the movement of sediment, nutrients, pesticides, and other pollutants

resulting from agricultural, industrial, or other societal activities from the land to surface or groundwater or that optimize water use.

Central and Southern Florida (C&SF) Project for Flood Control and Other Purposes—A multipurpose project, first authorized by the U.S. Congress in 1948, to provide flood control, water supply protection, water quality protection, and natural resource protection.

Clean Water Act (CWA)—The Clean Water Act is the cornerstone of surface-water quality protection in the United States. The statute employs a variety of regulatory and nonregulatory tools to reduce direct pollutant discharges into waterways, finance municipal wastewater treatment facilities, and manage polluted runoff. These tools help to achieve the broader goal of restoring and maintaining the chemical, physical, and biological integrity of the nation's waters so that they can support the protection and propagation of fish, shellfish, and wildlife and recreation in and on the water.

Comprehensive Everglades Restoration Plan (CERP)—The plan for the restoration of the greater Everglades ecosystem authorized by Congress in 2000.

Conceptual ecological models—Nonquantitative, verbal or diagrammatic hypotheses about the major anthropogenic and natural drivers and stressors on natural systems, the ecological effects of these stressors, and the biological attributes or indicators of these ecological responses. They are used as planning tools for research and adaptive management.

Critical Projects—Projects determined to be critical to the restoration of the South Florida ecosystem that were authorized in 1996 prior to the CERP. These projects are comparatively small and were undertaken by the U.S. Army Corps of Engineers and South Florida Water Management District. They are being implemented along with the CERP projects.

Decomp—Short title for Water Conservation Area 3 Decompartmentalization and Sheet Flow Enhancement—Part 1 project.

Endangered Species Act (ESA)—A U.S. law passed in 1973 to protect species listed by the federal government as threatened or endangered from extinction. It provides penalties for the taking of such species and requires any federal agency to consult with the U.S. Fish and Wildlife Service (or National Marine Fisheries Service for marine species) before undertaking or funding any action that could jeopardize the continued existence or recovery of listed species.

Estuary—The portion of the Earth’s coastal zone where seawater, freshwater, and land, interact, typically arms of the sea where tide meets river currents.

Everglades—A mosaic of wetlands, uplands, and coastal areas that extends from the Kissimmee River basin to Florida Bay.

Everglades Agricultural Area (EAA)—Land in the northern Everglades south of Lake Okeechobee that was drained for agricultural use.

Everglades Construction Project—Twelve interrelated construction projects located between Lake Okeechobee and the Everglades. Six stormwater treatment areas (STAs, or constructed wetlands) totaling more than 47,000 acres are the cornerstone of the project. The STAs rely on physical and biological processes to reduce the level of total phosphorous entering the Everglades to an interim goal of 50 parts per billion.

Everglades Depth Estimation Network (EDEN)—A U.S. Geological Survey surface-water hydrological monitoring network in support of the monitoring and assessment plan (MAP) projects that is intended to provide the hydrologic data necessary to integrate hydrologic and biological responses to the CERP during MAP performance measurement assessment and evaluation for the Greater Everglades module.

Everglades Landscape Model (ELM)—Model used to predict the landscape response to different water management scenarios. ELM consists of a set of integrated modules to understand ecosystem dynamics at a regional scale and simulates the biogeochemical processes associated with hydrology, nutrients, soil formation, and vegetation succession. Its main components include hydrology, water quality, soils, periphyton, and vegetation.

Everglades Protection Area—As defined in the Everglades Forever Act, the Everglades Protection Area comprises Water Conservation Areas (WCAs) 1 (also known as the Arthur R. Marshall Loxahatchee National Wildlife Refuge), 2A, 2B, 3A, 3B; the Arthur R. Marshall Loxahatchee National Wildlife Refuge; and the Everglades National Park.

Everglades Restoration Transition Plan (ERTP)—An initiative led by the U.S. Army Corps of Engineers (USACE), with support from a multi-agency team, to examine operational flexibilities and improve water management within WCA-3 and Everglades National Park. This effort has been necessitated by the pending October 2010 expiration of the 2006 biological opinion in support of the

Interim Operational Plan (IOP), which protects the Cape Sable seaside sparrow and its habitat.

Exotic species—An introduced species not native to the place where it is found. Usually used for species introduced from outside a country's borders.

Extirpated species—A species that has become extinct in a given area.

Flow—The volume of water that passes a given point per unit of time, including in-stream flow requirements, minimum flow, and peak flow. "Flow" is used generically within the text to mean the movement of volumes of water across the landscape, and it incorporates the concepts of volumetric flow rate (e.g., cubic feet per second), velocity, and direction. Volumetric flow rate may be estimated for large averaging times, such as acre-feet per year, as in the South Florida Water Management Model and the Natural Systems Model, and also on a short-term ("instantaneous") basis by other models, as discussed in Chapter 4.

Flux—The rate of transfer of fluid, particles, or energy across a given surface.

Footprint—The area of productive land and aquatic ecosystems required to produce the resources used and to assimilate the wastes produced by a defined population at a specified material standard of living, wherever that land might be located.

Foundation projects—Non-CERP Everglades restoration activities, many of which are essential (the foundation) for completion of the CERP.

General Circulation Model (GCM)—A numerical model used to simulate the circulation of the ocean (OGCM) or atmosphere (AGCM). Coupled ocean-atmosphere GCMs also are used to simulate climate over long periods resulting from changes in boundary conditions such as greenhouse-gas forcing of temperature.

Geographic information system (GIS)—A map-based data storage and retrieval system.

Guidance memorandum—A document of prescribed format that officially captures decisions of the program managers and promulgates their guidance regarding implementation of the CERP. The guidance memoranda address an array of subjects including definitions, direction, and procedures for reporting, Web management, financial management, and program controls.

Habitat Conservation Plan—A plan required by Section 10(a)(2)(A) of the Endangered Species Act for an applicant for an incidental take permit. The plan is required to include, among other things, the impacts that are likely to result from the taking and the measures the permit applicant will undertake to minimize and mitigate such impacts. Habitat conservation plans reduce conflicts among listed species and economic use or development activities, allowing for the development of “creative partnerships” between the public and private sectors, designed to make the process work for both landowners and species.

Habitat Suitability Index (HSI)—Tool used to define, in relative terms, the quality of the habitat for various plant and animal species. HSIs can be used as the first approximation toward quantifying the relationships identified in various conceptual ecological models.

Herbert Hoover Dike—A dike system surrounding Lake Okeechobee that provides flood and storm damage reduction and other water control benefits in central and south Florida. It consists of 143 miles of levees with 19 culverts, hurricane gates, and other water control structures.

Hydroperiod—Annual temporal pattern of water levels.

Incremental adaptive restoration (IAR)—An alternative framework called for in NRC (2007) for advancing natural resource restoration in the Everglades. The aim of IAR is to resolve decision-critical scientific uncertainties and to address project sequencing constraints to improve the pace of restoration. As conceived, the IAR approach makes investments in restoration project increments that are large enough to secure significant environmental benefits, while simultaneously testing hypotheses selected to resolve important scientific uncertainties about the response of the system to management interventions. Such steps would likely be smaller than the CERP projects because the purpose of IAR is to take actions that help address some sources of delay in the pace of restoration progress as well as to promote learning that can guide the remainder of project design. As an application of adaptive management, IAR would require rigorous monitoring and assessment to test hypotheses, yielding valuable information that can expedite future decision making and improve future project design.

Integrated Delivery Schedule (IDS)—The schedule of implementation of restoration projects for the Everglades. It includes Comprehensive Everglades Restoration Plan (CERP) projects and the “Foundation Projects,” those that precede CERP, such as Kissimmee River Restoration and Modified Water Deliveries to Everglades National Park.

Interagency Modeling Center (IMC)—An equal partnership between the U.S. Army Corps of Engineers Jacksonville District and the South Florida Water Management District that serves as the modeling services single point of responsibility for the CERP. It provides, coordinates, and oversees the modeling needs and efforts of each project delivery team and the Restoration, Coordination, and Verification Program, or RECOVER.

Interim goal—A means by which the restoration success of the CERP may be evaluated throughout the implementation process.

Interim target—A means by which the success of the CERP in providing for water-related needs of the region, including water supply and flood protection, may be evaluated throughout the implementation process.

Invasive species—Species of plants or animals, both native and exotic, that aggressively invade habitats and cause multiple ecological changes.

Loxahatchee Impounded Landscape Assessment (LILA)—A study in two 17-hectare plots in the Loxahatchee National Wildlife Refuge that simulates a scaled-down Everglades ecosystem. The objective of LILA is to define hydrologic regimes that sustain a healthy Everglades ridge and slough ecosystem.

Marl—A type of wetland soil high in clay and carbonates. Hydroperiod is a critical determinant of marl formation.

Master Agreement—An agreement signed on August 13, 2009 by the Department of the Army and the South Florida Water Management District to promote cooperation between the two agencies for construction, operation, maintenance and repair of CERP projects and to provide for financial sharing of CERP obligations.

Master Implementation Sequencing Plan (MISP)—Specifies the sequence in which CERP projects are planned, designed, and constructed.

Modified Water Deliveries to Everglades National Park (Mod Waters)—A project authorized in 1989 to restore more natural flows into Everglades National Park by reducing impediments to flow caused by the Tamiami Trail. A major part of the CERP implementation depends on the completion of Mod Waters; construction on a 1-mile bridge on Tamiami Trail started in December 2009.

Monitoring and Assessment Plan (MAP)—The primary tool by which RECOVER assesses the performance of the CERP.

National Pollution Discharge Elimination System (NPDES)—As authorized by the Clean Water Act, this permit program controls water pollution by regulating point sources that discharge pollutants into the waters of the United States.

Natural system—According to the Water Resources Development Act of 2000 (WRDA 2000), all land and water managed by the federal government or the state within the South Florida ecosystem, including Water Conservation Areas, sovereign submerged land, Everglades National Park, Biscayne National Park, Big Cypress National Preserve, other federal or state (including a political subdivision of a state) land that is designated and managed for conservation purposes, and any tribal land that is designated and managed for conservation purposes, as approved by the tribe.

Natural System Model (NSM)—Model that simulates hydropatterns before canals, levees, dikes, and pumps were built. The NSM mimics frequency, duration, depth, and spatial extent of water inundation under pre-management (i.e., natural) hydrologic conditions. In many cases, those pre-management water levels are used as a target for hydrologic restoration assuming that restoration of the hydrologic response that existed prior to drainage of the system would lead to restoration of natural habitats and biota.

Natural System Regional Simulation Model (NSRSM)—Application of the updated Regional Systems Model to simulate the natural system hydrology of South Florida. The use of refined input parameters, in combination with the model's improved hydrologic simulation engine, results in simulations that reasonably represent pre-drainage (mid-1800) hydrology within an estimated range of performance.

Original Everglades—The pre-drainage Everglades, or that which existed prior to the construction of drainage canals beginning in the late 1800s.

Part per billion (ppb)—A measure of concentration equivalent to one microgram of solute per liter of solution.

Part per million (ppm)—A measure of concentration equivalent to one milligram of solute per liter of solution.

Passive adaptive management—Adaptive management by which a preferred course of action is selected based on existing information and understanding. Outcomes are monitored and evaluated, and subsequent decisions (e.g., adjustments in design or operations, the design of subsequent projects, etc.)

are adjusted based on improved understanding. It is distinguished from active adaptive management, which involves designing management actions as experimental activities, to enhance the learning process.

Performance measure—A quantifiable indicator of ecosystem response to changes in environmental conditions.

Periphyton—A biological community of algae, bacteria, fungi, protists, and other microorganisms. In the Everglades, periphyton grows on top of the soil surface—attached to the stems of rooted vegetation—and in the water column or at the water surface, sometimes in association with other floating vegetation.

Programmatic Regulations—Procedural framework and specific requirements called for in Section 601(h)(3) of WRDA 2000. The programmatic regulations are intended to guide implementation of the CERP and to ensure that the goals and purposes of the CERP are achieved. The final rule for the Programmatic Regulations (33 CFR § 385) was issued in November 2003.

Project delivery team (PDT)—An interdisciplinary group that includes representatives from the implementing agencies. PDTs develop the products necessary to deliver the project.

Project implementation report (PIR)—A decision document that bridges the gap between the conceptual design contained in the comprehensive plan and the detailed design necessary to proceed to construction.

Project management plan (PMP)—A document that establishes the project's scope, schedule, costs, funding requirements, and technical performance requirements (including the various functional area's performance and quality criteria) and that will be used to produce and deliver the products that comprise the project.

RECOVER—The Restoration, Coordination, and Verification Program (RECOVER) is an arm of the CERP responsible for linking science and the tools of science to a set of systemwide planning, evaluation, and assessment tasks. RECOVER's objectives are to evaluate and assess CERP performance; refine and improve the CERP during the implementation period; and ensure that a systemwide perspective is maintained throughout the restoration program. RECOVER conducts scientific and technical evaluations and assessments for improving CERP's ability to restore, preserve, and protect the South Florida ecosystem while providing for

the region's other water-related needs. RECOVER communicates and coordinates the results of these evaluations and assessments.

Regional Simulation Model (RSM)—A regional finite-volume-based hydrologic model developed principally for application in South Florida that simulates the coupled movement and distribution of groundwater and surface water throughout the model domain using a Hydrologic Simulation Engine to simulate the natural hydrology and a Management Simulation Engine to simulate water control operations.

Regional Simulation Model Water Quality Engine (RSMWQ)—A water quality engine for the South Florida Regional Simulation Model (RSM). It has not yet been used by CERP decision makers.

Ridge—Elevated areas of sawgrass habitat that rise above the foot-and-a-half deeper sloughs. A ridge may be submerged or above the water surface.

River of Grass Purchase—A proposal to acquire land in the Everglades Agricultural Area for Everglades restoration purposes. The initial proposal would have acquired more than 180,000 acres of land from U.S. Sugar Corporation; economic and legal factors have led to the current proposal, which is to acquire 26,800 acres, with options to acquire an additional 153,200 acres over the next 10 years.

Savings Clause—Provision of WRDA 2000 that is designed to ensure that an existing legal source of water (e.g., agricultural or urban water supply, water supply for Everglades National Park, water supply for fish and wildlife) is not eliminated or transferred until a replacement source of water of comparable quantity and quality—as was available on the date of enactment of WRDA 2000—is available and that existing levels of flood protection are not reduced.

Sawgrass plain—An unbroken expanse of dense, tall (up to 10 feet) sawgrass that originally covered most of the northern Everglades. Agricultural crops, mainly sugar cane, have replaced most of the sawgrass plain area, but some tall sawgrass remains in the water conservation areas.

Sheet flow—Water movement as a broad front with shallow, uniform depth.

Slough—A depression associated with swamps and marshlands as part of a bayou, inlet, or backwater; contains areas of slightly deeper water and a slow current and can be thought of as the broad, shallow rivers of the Everglades.

South Florida ecosystem—An area consisting of the lands and waters within the boundary of the South Florida Water Management District, including the built environment, the Everglades, the Florida Keys, and the contiguous nearshore coastal waters of South Florida (also known as Greater Everglades ecosystem).

South Florida Ecosystem Restoration Task Force (SFERTF or Task Force)—The Task Force was established by WRDA 1996 to coordinate policies, programs, and science activities among the many restoration partners in South Florida. Its 14 members include the secretaries of Interior (chair), Commerce, Army, Agriculture, and Transportation; the Attorney General; and the Administrator of the Environmental Protection Agency; or their designees. The Secretary of the Interior appoints one member each from the Seminole Tribe of Florida and the Miccosukee Tribe of Indians of Florida. The secretary of the interior also appoints, based on recommendations of the governor of Florida, two representatives of the State of Florida, one representative of the South Florida Water Management District, and two representatives of local Florida governments.

South Florida Water Management Model (SFWMM)—A model that simulates hydrology and water systems. It is widely accepted as the best available tool for analyzing structural and/or operational changes to the complex water management system in South Florida at the regional scale.

Stormwater Treatment Area (STA)—A human-constructed wetland area to treat urban and agricultural runoff water before it is discharged to the natural areas.

Submerged aquatic vegetation (SAV)—Plants that grow completely below the water surface.

System Status Report (SSR)—A biennial report produced by RECOVER designed to assess and document progress towards meeting performance measure targets and interim and long-term goals. Every five years, this SSR will provide the scientific information on the status of the ecosystem's response to CERP implementation and will be integrated into the Report to Congress.

Total maximum daily load (TMDL)—A calculation of the maximum amount of a pollutant that a body of water can receive and still safely meet water quality standards.

Total phosphorus (TP)—Sum of phosphorus in dissolved and particulate forms.

Tree island—Patch of forest in the Everglades marsh occurring in the central peatlands and the peripheral marl prairies of the southern and southeastern Everglades and on higher ground than ridges. Sizes range from as small as one-hundredth of an acre to hundreds of acres.

Water Conservation Areas (WCAs)—Everglades marshland areas that were modified for use as storage to prevent flooding, to irrigate agriculture land and recharge well fields, to supply water for Everglades National Park, and for general water conservation. WCA-1, WCA-2A, WCA-2B, WCA-3A, and WCA-3B comprise five surface-water management basins in the Everglades; bounded by the Everglades Agricultural Area on the north and the Everglades National Park basin on the south, the WCAs are confined by levees and water control structures that regulate the inflows and outflows to each one of them. Restoration of more natural water levels and flows to the WCAs is a main objective of the CERP.

Water reservations—According to WRDA 2000, the state shall, under state law, make sufficient reservations of water provided by each CERP project for the natural system in accordance with the Project Implementation Report for that project and consistent with the plan before water made available by a project is permitted for a consumptive use or otherwise made unavailable.

Water Resources Development Act (WRDA) of 2000—Legislation that authorized the Comprehensive Everglades Restoration Plan as a framework for modifying the Central and South Florida Project to increase future water supplies, with the appropriate quality, timing, and distribution, for environmental purposes so as to achieve a restored Everglades natural system as much as possible, while at the same time meeting other water-related needs of the ecosystem. WRDAs are passed periodically, the most recent one having been enacted in 2007; they provide the mechanism for authorizing CERP activities.

Water year—Time convention used as a basis for processing stream flow and other hydrologic data. In the Northern Hemisphere, the water year begins October 1 and ends September 30; in the Southern Hemisphere, it begins July 1 and ends June 30. The water year is designated by the calendar year in which it ends.

Wetlands—Areas that are inundated or saturated by surface water or groundwater at a frequency and duration sufficient to support a prevalence of vegetative or aquatic life that requires saturated or seasonally saturated soil conditions for growth and reproduction.

Yellow Book—This is the common name for the *Central and Southern Florida Comprehensive Review Study Final Integrated Feasibility Report and Programmatic Environmental Impact Statement* (USACE and SFWMD, 1999), which laid out the Comprehensive Everglades Restoration Plan.

Appendixes

A

National Research Council Everglades Reports

Progress Toward Restoring the Everglades: The Second Biennial Review, 2008 (2008)

This report is the second biennial evaluation of progress being made in the Comprehensive Everglades Restoration Plan (CERP), a multibillion-dollar effort to restore historical water flows to the Everglades and return the ecosystem closer to its natural state. Launched in 2000 by the U.S. Army Corps of Engineers and the South Florida Water Management District, the CERP is a multi-organization planning process that includes approximately 50 major projects to be completed over the next several decades. The report concludes that budgeting, planning, and procedural matters are hindering a federal and state effort to restore the Florida Everglades ecosystem, which is making only scant progress toward achieving its goals. Good science has been developed to support restoration efforts, but future progress is likely to be limited by the availability of funding and current authorization mechanisms. Despite the accomplishments that lay the foundation for CERP construction, no CERP projects have been completed to date. To begin reversing decades of decline, managers should address complex planning issues and move forward with projects that have the most potential to restore the natural ecosystem.

Progress Toward Restoring the Everglades: The First Biennial Review, 2006 (2007)

This report is the first in a congressionally mandated series of biennial evaluations of the progress being made by the CERP, a multibillion-dollar effort to restore historical water flows to the Everglades and return the ecosystem closer to its natural state, before it was transformed by drainage and by urban and agricultural development. The report finds that progress has been made in developing the scientific basis and management structures needed to support a massive effort to restore the Florida Everglades ecosystem. However, some

important projects have been delayed due to several factors including budgetary restrictions and a project planning process that can be stalled by unresolved scientific uncertainties. The report outlines an alternative approach that can help the initiative move forward even as it resolves remaining scientific uncertainties. The report calls for a boost in the rate of federal spending if the restoration of Everglades National Park and other projects are to be completed on schedule.

***Re-Engineering Water Storage in the Everglades:
Risks and Opportunities*** (2005)

Human settlements and flood control structures have significantly reduced the Everglades, which once encompassed more than 3 million acres of slow-moving water enriched by a diverse biota. The CERP was formulated in 1999 with the goal of restoring the original hydrologic conditions of the remaining Everglades. A major feature of this plan is providing enough storage capacity to meet human and ecological needs. This report reviews and evaluates not only storage options included in the plan, but also other options not considered in the plan. Along with providing hydrologic and ecological analyses of the size, location, and functioning of water storage components, the report also discusses and makes recommendations on related critical factors, such as timing of land acquisition, intermediate states of restoration, and tradeoffs among competing goals and ecosystem objectives.

The CERP imposes some constraints on sequencing of its components. The report concludes that two criteria are most important in deciding how to sequence components of such a restoration project: (1) protecting against additional habitat loss by acquiring or protecting critical lands in and around the Everglades and (2) providing ecological benefits as early as possible.

There is a considerable range in the degree to which various proposed storage components involve complex design and construction measures, rely on active controls and frequent equipment maintenance, and require fossil fuels or other energy sources for operation. The report recommends that, to the extent possible, the CERP should develop storage components that have fewer of those requirements, and are thus less vulnerable to failure and more likely to be sustainable in the long term.

Further, as new information becomes available and as the effectiveness and feasibility of various restoration components become clearer, some of the earlier adaptation and compromises might need to be revisited. The report recommends that methods be developed to allow tradeoffs to be assessed over broad spatial and long temporal scales, especially for the entire ecosystem, and gives an example of what an overall performance indicator for the Everglades system might look like.

***Adaptive Monitoring and Assessment for the
Comprehensive Everglades Restoration Plan*** (2003)

A key premise of the CERP is that restoring the historical hydrologic regime in the remaining wetlands will reverse declines in many native species and biological communities. Given the uncertainties that will attend future responses of Everglades ecosystems to restored water regimes, a research, monitoring, and adaptive management program is planned. This report assessed the extent to which the restoration effort's "monitoring and assessment plan" included the following elements crucial to any adaptive management scheme: (1) clear restoration goals and targets, (2) a sound baseline description and conceptualization of the system, (3) an effective process for learning from management actions, and (4) feedback mechanisms for improving management based on the learning process.

The report concludes that monitoring needs must be prioritized, because many goals and targets that have been agreed to may not be achievable or internally consistent. Priorities could be established based on the degree of flexibility or reversibility of a component and its potential impact on future management decisions. Such a prioritization should be used for scheduling and sequencing of projects, for example. Monitoring that meets multiple objectives (e.g., adaptive management, regulatory compliance, and a "report card") should be given priority.

Ecosystem-level, systemwide indicators should be developed, such as land-cover and land-use measures, an index of biotic integrity, and diversity measures. Region-wide monitoring of human and environmental drivers of the ecosystem, especially population growth, land-use change, water demand, and sea level rise are recommended. Monitoring, modeling, and research should be well integrated, especially with respect to defining the restoration reference state and using "active" adaptive management.

Does Water Flow Influence Everglades Landscape Patterns? (2003)

A commonly stated goal of the CERP is to "get the water right." This has largely meant restoring the timing and duration of water levels and the water quality in the Everglades. Water flow (speed, discharge, direction) has been considered mainly in the coastal and estuarine system, but not elsewhere. Should the restoration plan be setting targets for flows in other parts of the Everglades as well?

There are legitimate reasons why flow velocities and discharges have thus far not received greater emphasis in the plan. These include a relative lack of field information and poor resolution of numerical models for flows. There are,

however, compelling reasons to believe that flow has important influences in the central Everglades ecosystem. The most important reason is the existence of major, ecologically important landforms—parallel ridges, sloughs, and “tree islands”—are aligned with present and inferred past flow directions. There are difficulties in interpreting this evidence, however, as it is essentially circumstantial and not quantitative.

Alternative mechanisms by which flow may influence this landscape can to some extent be evaluated from short-term research on underlying bedrock topography, detailed surface topographic mapping, and accumulation rates of suspended organic matter. Nonetheless, more extensive and long-term research will also be necessary, beginning with the development of alternative conceptual models of the formation and maintenance of the landscape to guide a research program. Research on maintenance rather than evolution of the landscape should have higher priority because of its direct impact on restoration. Monitoring should be designed for the full range of flow conditions, including extreme events.

Overall, flows approximating historical discharges, velocities, timing, and distribution should be considered in restoration design, but quantitative flow-related performance measures are not appropriate until there is a better scientific understanding of the underlying science. At present, neither a minimum nor a maximum flow to preserve the landscape can be established.

Florida Bay Research Programs and Their Relation to the Comprehensive Everglades Restoration Plan (2002)

This report of the Committee on Restoration of the Greater Everglades Ecosystem (CROGEE) evaluated Florida Bay studies and restoration activities that potentially affect the success of the CERP. Florida Bay is a large, shallow marine system immediately south of the Everglades, bounded by the Florida Keys and the Gulf of Mexico. Some of the water draining from the Everglades flows directly into northeast Florida Bay. Other freshwater drainage reaches the bay indirectly from the northwest.

For several decades until the late 1980s, clear water and dense seagrass meadows characterized most of Florida Bay. However, beginning around 1987, the seagrass beds began dying in the western and central bay. It is often assumed that increased flows to restore freshwater Everglades habitats will also help restoration of Florida Bay. However, the CERP may actually result in higher salinities in central Florida Bay than exist presently, and thus exacerbate the ecological problems. Further, some percentage of the proposed increase in fresh surface-water flow discharging northwest of the bay will eventually reach the central

bay, where its dissolved organic nitrogen may lead to algal blooms. Complicating the analysis of such issues is the lack of an operational bay circulation model.

The report notes the importance of additional research in the following areas: estimates of groundwater discharge to the bay; full characterization and quantification of surface runoff in major basins; transport and total loads of nitrogen and phosphorous from freshwater sources, especially in their organic forms; effects on nutrient fluxes of decreasing freshwater flows into the northeastern bay, and of increasing flows northwest of the bay; and the development of an operational Florida Bay circulation model to support a bay water quality model and facilitate analysis of CERP effects on the bay.

***Science and the Greater Everglades Ecosystem Restoration:
An Assessment of the Critical Ecosystems Study Initiative*** (2003)

The Everglades represents a unique ecological treasure, and a diverse group of organizations is currently working to reverse the effects of nearly a century of wetland drainage and impoundment. The path to restoration will not be easy, but sound scientific information will increase the reliability of the restoration, help enable solutions for unanticipated problems, and potentially reduce long-term costs. The investment in scientific research relevant to restoration, however, decreased substantially within some agencies, including one major Department of the Interior (DOI) science program, the Critical Ecosystem Studies Initiative (CESI). In response to concerns regarding declining levels of funding for scientific research and the adequacy of science-based support for restoration decision making, the U.S. Congress instructed the DOI to commission the National Academy of Sciences to review the scientific component of the CESI and provide recommendations for program management, strategic planning, and information dissemination.

Although improvements should be made, this report notes that the CESI has contributed useful science in support of the DOI's resource stewardship interests and restoration responsibilities in South Florida. It recommends that the fundamental objectives of the CESI research program remain intact, with continued commitment to ecosystem research. Several improvements in CESI management are suggested, including broadening the distribution of requests for proposals and improving review standards for proposals and research products. The report asserts that funding for CESI science has been inconsistent and as of 2002 was less than that needed to support the DOI's interests in and responsibilities for restoration. The development of a mechanism for comprehensive restoration-wide science coordination and synthesis is recommended to enable improved integration of scientific findings into restoration planning.

***Regional Issues in Aquifer Storage and Recovery for Everglades Restoration:
A Review of the ASR Regional Study Project Management Plan of the
Comprehensive Everglades Restoration Plan*** (2002)

The report reviews a comprehensive research plan on Everglades restoration drafted by federal and Florida officials that assesses a central feature of the restoration: a proposal to drill more than 300 wells funneling up to 1.7 billion gallons of water a day into underground aquifers, where it would be stored and then pumped back to the surface to replenish the Everglades during dry periods. The report says that the research plan goes a long way to providing information needed to settle remaining technical questions and clearly responds to suggestions offered by scientists in Florida and in a previous report by the NRC.

Aquifer Storage and Recovery in the Comprehensive Everglades Restoration Plan: A Critique of the Pilot Projects and Related Plans for ASR in the Lake Okeechobee and Western Hillsboro Areas (2001)

Aquifer storage and recovery (ASR) is a major component in the CERP, which was developed by the U.S. Army Corps of Engineers (USACE) and the South Florida Water Management District (SFWMD). The plan would use the upper Floridian aquifer to store large quantities of surface water and shallow groundwater during wet periods for recovery during droughts.

ASR may limit evaporation losses and permit recovery of large volumes of water during multi-year droughts. However, the proposed scale is unprecedented and little subsurface information has been compiled. Key unknowns include impacts on existing aquifer uses, suitability of source waters for recharge, and environmental and/or human health impacts due to water quality changes during subsurface storage.

To address these issues, the USACE and SFWMD proposed aquifer storage recharge pilot projects in two key areas. The CROGEE charge was to examine a draft of their plans from a perspective of adaptive management. The report concludes that regional hydrogeologic assessment should include development of a regional-scale groundwater flow model, extensive well drilling and water quality sampling, and a multi-objective approach to ASR facility siting. It also recommends that water quality studies include laboratory and field bioassays and ecotoxicological studies, studies to characterize organic carbon of the source water and anticipate its effects on subsurface biogeochemical processes, and laboratory studies. Finally, it recommends that pilot projects be part of adaptive assessment.

B

Timeline of Significant Events in South Florida Ecosystem Management and Restoration

- 1934** Everglades National Park is authorized.
- 1948** Congress authorizes the Central and Southern Florida Flood Control Project to control the water flow in the Everglades. From 1949 to 1969, U.S. Army Corps of Engineers (USACE) and the Central and Southern Florida Flood Control District built and operated the project works.
- 1968** Biscayne National Park is established as a national monument; expanded to a national park in 1980.
- 1972** The Florida Water Resources Act establishes fundamental water policy for Florida, attempting to meet human needs and sustain natural systems putting in place a comprehensive strategic program to preserve and restore the Everglades ecosystem.
- 1974** Big Cypress National Preserve is created.
- 1983** Florida Governor's Save Our Everglades Program outlines a six-point plan for restoring and protecting the South Florida ecosystem so that it functions more like it did in the early 1900s.
- 1987** The Florida Surface Water Improvement and Management Act requires the five Florida water management districts to develop plans to clean up and preserve Florida lakes, bays, estuaries, and rivers.
- 1989** The Modified Water Deliveries to Everglades National Park Project is authorized.

- 1990** The Florida Preservation 2000 Act establishes a coordinated land acquisition program at \$300 million per year for 10 years to protect the integrity of ecological systems and to provide multiple benefits, including the preservation of fish and wildlife habitat, recreation space, and water recharge areas.
- 1992** Federal and state parties enter into a Consent Decree on Everglades water quality issues in federal court. Under the agreement, all parties commit themselves to achieving both the water quality and quantity necessary to protect and restore the unique ecological characteristics of the Arthur R. Marshall Loxahatchee National Wildlife Refuge and Everglades National Park.
- The Water Resources Development Act (WRDA) of 1992 authorizes the Kissimmee River Restoration Project and the C&SF Project Restudy, a comprehensive review study for restoring the hydrology of South Florida.
- 1994** The Florida Everglades Forever Act enacts into state law the settlement provisions of federal-state water quality litigation and provides a financing mechanism for the state to advance water quality improvements in the Everglades by constructing more than 44,000 acres of stormwater treatment areas (STAs) for water entering the Everglades Protection Area. The act also requires the South Florida Water Management District to ensure that best management practices (BMPs) are used to reduce phosphorus in waters discharged into the STAs from the Everglades Agricultural Area (EAA) and other areas. The rule-making process by which the numeric total phosphorus criterion of 10 parts per billion (ppb) is proposed for the Everglades Protection Area also was established by this act.
- 1996** WRDA 1996 formally establishes the intergovernmental South Florida Ecosystem Restoration Task Force to coordinate the restoration effort among the state, federal, tribal, and local agencies. It authorizes the USACE to implement the critical restoration projects (see Box 2-3).
- Section 390 of the Farm Bill grants \$200 million to conduct restoration activities in the South Florida ecosystem.
- 1999** WRDA 1999 extends Critical Restoration Project authority until 2003 and authorizes two pilot infrastructure projects proposed in the Comprehensive Everglades Restoration Plan (CERP).

The Florida Forever Act improves and continues the coordinated land acquisition program initiated by the Florida Preservation 2000 Act of 1990 and commits \$300 million per year for 10 years.

- 2000** WRDA 2000 authorizes the CERP as a framework for modifying the Central and Southern Florida Project to increase future water supplies, with the appropriate timing and distribution, for environmental purposes so as to achieve a restored Everglades ecosystem, while at the same time meeting other water-related needs of the ecosystem. WRDA 2000 includes \$1.4 billion in authorizations for 10 initial Everglades infrastructure projects, 4 pilot projects, and an adaptive management and monitoring program. It also grants programmatic authority for projects with immediate and substantial restoration benefits at a total cost of \$206 million and establishes a 50 percent federal cost share for implementation of the CERP and for operation and maintenance.

The Florida legislature passes the Lake Okeechobee Protection Act, a phased, comprehensive program designed to restore and protect the lake.

- 2003** Programmatic Regulations are issued that establish a procedural framework and set specific requirements that guide implementation of the CERP to ensure that the goals and purposes of the CERP are achieved.

- 2004** The State of Florida unveils plan to accelerate restoration of America's Everglades (Acceler8).

- 2005** The State of Florida announces the Lake Okeechobee Estuary Recovery Plan to help restore the ecological health of Lake Okeechobee and the St. Lucie and Caloosahatchee estuaries.

- 2007** The Florida state legislature authorizes the Northern Everglades and Estuaries Protection Program, which expands the Lake Okeechobee Protection Act to strengthen protection for the northern Everglades by restoring and preserving the Lake Okeechobee, Caloosahatchee, and St. Lucie watersheds, including the estuaries.

WRDA 2007 authorizes three projects under the CERP: the Indian River Lagoon-South Project, Picayune Strand Restoration, and the Site 1 Impoundment Project. WRDA 2007 also increases funding

limits for WRDA 1996 critical projects and for three WRDA 1999 authorized pilot projects.

2008 The State of Florida announces that it will begin negotiations to acquire 187,000 acres of farmland in the EAA from the U.S. Sugar Corporation for \$1.75 billion for the purpose of restoration, and a negotiated proposal to acquire the land for \$1.34 billion is approved by the South Florida Water Management District's governing board.

2009 The South Florida Water Management District's governing board approves a revised plan to purchase 73,000 acres of farmland in the EAA from the U.S. Sugar Corporation for \$536 million, with options to purchase the remaining 107,000 acres within the next 10 years.

Federal and state parties enter into a "master agreement" detailing how the costs and duties will be shared for 68 projects that Congress approved in 2000, beginning with the reclamation of 55,000 acres in the Picayune Strand.

2010 The South Florida Water Management District's governing board approves a revised plan to purchase 26,800 acres of land for approximately \$197 million, while retaining the option to acquire over 153,000 additional acres over the next ten years.

SOURCES: SFERTF (2006); <http://everglades.fiu.edu/reclaim/timeline/index.htm>; <http://www.washingtonpost.com/wp-dyn/content/article/2008/06/24/AR2008062401140.html>.

C

Status of Key Non-CERP Projects

KISSIMMEE RIVER RESTORATION

Status: This project will backfill a total of 22 miles of C-38 and re-establish approximately 40 miles of meandering river channel. Three of the four phases (reaches) of the Kissimmee River Restoration Project to backfill the initial 14 miles of C-38 are complete, restoring a 24-mile section of the original river channel. Most of the 102,061 acres of land needed for the restoration have been acquired. The last remaining construction phases will backfill the final 12 miles of C-38. Phase 4B backfilling began in 2009 and was completed in 2010.

Observed Benefits: About 7,700 acres of formerly drained portions of the river's floodplain are now experiencing enhanced inundation and are reverting back to wetland habitat. A comprehensive evaluation program for tracking environmental responses to the restoration is gauging the success of the project in meeting its goal of ecological integrity for the river and the floodplain. Densities of long-legged wading birds on the restored floodplain have exceeded restoration expectations each year since 2002, with the exception of the drought year 2007.

Integrated Financial Plan (IFP; SFERTE, 2009) Start Date: 1994

Current Estimated Completion Date: 2014

Original Estimated Cost (WRDA 1992): \$427M

2009 IFP Estimated Cost: \$619M

EVERGLADES CONSTRUCTION PROJECT

Status: Construction of Compartments B and C build-outs is scheduled for completion in December 2010. Flow-through operation of stormwater treatment area (STA)-2 Cell 4, and STA-6 Section 2 began in 2007 and 2008, respectively. STA-5 Flow-way 3, which became flow-capable in 2006 and began limited operation in 2008, dried out during drought conditions in water year (WY) 2009. This

flow-way was off-line for half of WY2010 due to Compartment C construction activities. A major earthwork project was completed in the southern portion of STA-5 Cell 1A in early 2009 to fill in a west-to-east oriented slough and improve flow distribution and performance in this cell. Approximately 80–100 acres of the slough were filled with ~400,000 cubic yards of material obtained from a borrow area immediately to the west of the treatment cell. Conversion from emergent to submerged aquatic vegetation (SAV) has been completed in STA-1W Cell 3 (WY2009), is continuing in STA-3/4 Cell 1B, and has been initiated in STA-2 Cell 2. Large-scale bulrush planting was conducted in WY2009–2010. Planted areas included STA-5 Cells 1A and 1B; STA-1E Cells 5, 6, and 7; STA-1W Cells 5A and 5B; and STA 3/4 Cell 1A.

Observed Benefits: Since 1994, the Everglades Construction Project (ECP) STAs have retained more than 1,400 metric tons (mt) of total phosphorus (TP) that would have otherwise entered the Everglades Protection Area, reducing TP loads by 60–86 percent.

Start Date: Authorized in 1994, Everglades Forever Act

Current Estimated Completion Date: Not available

Original Estimated Cost: \$825M

Current Estimated Cost: \$836.2M

MODIFICATIONS TO C-111 (SOUTH DADE)

Status: Currently, two interim pump stations and one permanent pump station have been completed, along with construction of a retention/detention zone, replacement of the Taylor Slough Bridge, and removal of 4.75 miles of spoil mounds along lower C-111. Two construction projects were recently completed and transferred to the sponsor; the S-331 Command and Control Center and the southern retention/detention center. Construction contracts were initiated in 2008 to complete earthwork for the detention flowway linking the B and C pump station detention areas. This extension expands the effective area being used to build a hydrologic barrier between Everglades National Park (ENP) and the L-31N Canal to reduce seepage losses from ENP. A construction contract to extend the S-332B North detention area and contain discharges from the 8.5 square mile area (SMA) STA component of the modify water delivering (MWD) project is anticipated in 2012.

Observed Benefits: Not yet fully implemented. Distribution of flows has improved downstream of the Taylor Slough bridge replacement and C-111 Spoil Mounds Removal areas.

IFP Start Date: 1994

Current Estimated Completion Date: 2017

Original Estimated Cost: \$121M (1994)

2009 IFP Estimated Cost: \$383.6M (\$118.2M appropriated thru fiscal year [FY]2009)

MODIFIED WATER DELIVERIES TO EVERGLADES NATIONAL PARK

Status: Construction features completed:

1. Spillway structures S-355A and B in the L-29 Levee
2. S-333 modifications
3. Tigertail Camp elevation
4. Pump Station S-356 between L-31N Canal and L-29 Canal (for MWD)
5. Levees and a seepage collector canal to provide flood mitigation for the east Everglades residential area (8.5 SMA)
6. S-331 Command and Control (cost shared with the C-111 [South Dade])

Work in progress:

1. Degradation of the L-67 Extension Canal and Levee (4 of 9 miles degraded)
2. Construction of the bridges and raising the road for the Tamiami Trail Modifications feature.

Future work:

3. Structures S-345 A, B, and C through the L-67A and C Levees
4. Structures S-349 A, B, and C in the L-67A Borrow Canal
5. Osceola Camp elevation design and construction
6. L-29 weirs

Observed Benefits: Not yet implemented.

IFP Start Date: 1990

Current Estimated Completion Date: 2013

Original Estimated Cost: \$98M (1989)

2009 IFP Estimated Cost: Information not found

NORTHERN EVERGLADES AND ESTUARIES PROTECTION PROGRAM

Status: In 2007, the Florida Legislature expanded the Lake Okeechobee Protection Act to include protection and restoration of the interconnected Kissimmee, Lake Okeechobee, Caloosahatchee, and St. Lucie watersheds. This interagency initiative, known as the Northern Everglades and Estuaries Protection Program

(NEEPP), focuses on the water storage and water treatment needed to help improve and restore the Northern Everglades and coastal estuaries. As part of this initiative, the SFWMD and the state will expand water storage areas, construct treatment marshes, and expedite environmental management initiatives to enhance the ecological condition of the lake and downstream coastal estuaries. The NEEPP requires the SFWMD, in collaboration with the Florida Department of Environmental Protection and the Florida Department of Agriculture and Consumer Services (FDACS) as coordinating agencies and in cooperation with local governments, to develop (1) the Lake Okeechobee Watershed Construction Project Phase II Technical Plan, (2) the St. Lucie River Watershed Protection Plan, and (3) the Caloosahatchee River Watershed Protection Plan. The Phase II Technical Plan was submitted to the legislature in February 2008 and the St. Lucie River and Caloosahatchee River Watershed Protection Plans were submitted in January 2009. While Northern Everglades projects have been conceptually identified in these plans, specific projects and activities will be included in the annual work plan for each fiscal year. Currently, the coordinating agencies are developing the Lake Okeechobee Protection Plan update, which will be submitted to the Florida Legislature early in 2011, and they will initiate the St. Lucie and Caloosahatchee River Watershed Protection Plan updates in 2011.

Observed Benefits: Coordinating agencies have been able to implement a large number of phosphorus reduction projects, including phosphorus source control grant programs for agricultural landowners, dairy best available technology pilot projects, soil amendment projects, isolated wetland restoration, remediation of former dairies, and regional public/private partnerships. Also, six Hybrid Wetland Treatment Technology projects have been constructed in a joint effort between the SFWMD and FDACS in St. Lucie and Lake Okeechobee watersheds. A comprehensive monitoring program for water quality in the lake and watershed and ecological indicators in the lake has been implemented. The Phase II Technical Plan is currently being implemented.

Start Date: 2007

Current Estimated Completion Date: Three phase implementation. The first phase occurs from 2008 to 2010 and includes continued implementation of ongoing measures and initiatives. Mid-term implementation measures will occur from 2011 to 2015 and long-term implementation measures will go beyond 2015.

2010 Estimated Cost: Since the enactment of the Lake Okeechobee Protection Act in 2000 and through 2010, approximately \$273 million has been invested through the state appropriations and SFWMD contributions for Lake Okeechobee

watershed restoration. Additional investment of approximately \$47.4 million has been made through the state appropriations, local governments, and SFWMD contributions for the St. Lucie and Caloosahatchee River watersheds since 2007. Future costs will be estimated in future plan updates.

INVASIVE SPECIES MANAGEMENT

Status: Progress is being made through several programmatic initiatives. An interagency group, the Everglades Cooperative Invasive Species Management Area, has been assembled to support and enhance a weed management database (WEEDAR). Biocontrol agents have been successfully developed and introduced for *Melaleuca*; efforts to develop agents for *Lygodium* are continuing; and conventional controls (physical removal, herbicide applications) and airborne surveys are carried out regularly. There has been development of new management approaches for invasive plants through applied research and information exchange between cooperators. Funding comes from specific projects under CERP (Melaleuca Eradication and Other Exotic Plants project, funded in 2002) and a variety of state-based projects. Surveys of invasive species are conducted by a variety of agencies (Florida Department of Environmental Protection [FLDEP], South Florida Water Management District [SFWMD], National Park Service [NPS]). Shortages of funds for monitoring and assessment, and development of biocontrol agent hampers further progress. Management of exotic animal species lags well behind efforts for invasive exotic plants.

Observed Benefits: *Melaleuca* is thought to be under control, with most populations subject to maintenance control. Biocontrol agents are being introduced for *Lygodium* and *Schinus*; *Lygodium* is considered a major threat to ecosystem integrity.

Start Date: 2007

Current Estimated Completion Date: TBD

Original Estimated Cost: information not found

Current Estimated Cost: information not found

LAKESIDE RANCH

Status: The enactment of Florida's Northern Everglades Initiative in 2007 expanded the Lake Okeechobee Protection Act to the entire northern Everglades system, and identified the Lakeside Ranch STA as an expedited project. The Lakeside Ranch STA involves the construction of a 2,000-acre STA at Lakeside Ranch that will provide approximately 19 metric tons of phosphorus reduction.

The STA that will be constructed in two phases (STA North and STA South). Phase I includes 925 acres of effective treatment area (\$31M construction cost) to be completed in February 2012. Phase II includes 1050 acres of effective treatment area (\$42M construction cost).

Observed Benefits: Not yet implemented

Start Date: October 2005

Current Estimated Completion Date: February 2012 for STA North, TBD for STA South

Original Estimated Cost: Information not found

2009 IFP Estimated Cost: \$105M

Everglades and South Florida (E&SF) Restoration: Critical Projects

East Coast Canal Structures (C-4)

Status: Construction of a gated water control structure (S-380) in the C-4 Basin in Dade County southeast of the Pennsuco wetlands is complete.

Observed Benefits: Raised surface and ground water levels to help preserve wetlands, increased aquifer recharge, and reduced seepage.

IFP Start Date: 1999

IFP Completion Date: 2003

2007 IFP Cost: \$3.7M

Tamiami Trail Culverts

Status: Original plans included Phase 1 placement of 77 culverts along Tamiami Trail (62 culverts west of State Road (SR) 92 in the Picayune Strand area, plus 15 culverts east of SR92 near the Big Cypress Preserve area), and Phase 2 resurfacing of Tamiami Trail related to these efforts. Construction of 17 Western Phase 1 Tamiami Trail Culverts between SR92 and SR29 in Collier County was completed in May 2006. This portion of Phase 1 has been included as a component of the Picayune Strand Restoration Project (authorized for construction in WRDA 2007) and will be cost-shared under that CERP program instead of the Critical Projects Authority. Since the initial planning, the scope of the project was modified due to budget and time constraints. The remainder of Phase 1 and Phase 2 work is on hold pending funding

Observed Benefits: Installation of Phase 1 culverts under the Tamiami Trail established more natural hydropatterns north and south of the highway, which is expected to enhance biological restoration in the area.

IFP Start Date: 1998

Current Estimated Completion Date: TBD

2009 IFP Estimated Cost: \$21.7M (for the original plan)

Florida Keys Carrying Capacity Study

Status: This project has been completed. It included the development of a decision-making tool, which will provide a comprehensive basis for coordinating and strengthening water and land-related planning efforts by local, state, and federal agencies.

Observed Benefits: The South Florida Regional Planning Council has agreed to steward and maintain the Carrying Capacity Impact Assessment Model as a decision-making tool. The Florida Marine Research Institute has also agreed to steward and maintain the databases.

IFP Start Date: 1997

IFP Completion Date: 2003

2009 IFP Estimated Cost: \$6M

Western C-11 Water Quality Treatment

Status: Construction is complete for this project to improve the quality and timing of stormwater discharges to the Everglades Protection Area from the Western C-11 Basin located in south central Broward County. The structures have been turned over from the U.S. Army Corps of Engineers (USACE) to the South Florida Water Management District (SFWMD) for operation and maintenance.

Observed Benefits: The S-381 structure in the C-11 Canal separates clean seepage flows from untreated agricultural and urban stormwater runoff. The S-9A Pump Station pumps clean flows into WCA-3A.

IFP Start Date: 1997

IFP Completion Date: 2006

2009 IFP Estimated Cost: \$18.1M

Seminole Tribe Big Cypress Reservation Water Conservation Plan

Status: Construction of the Phase 1 conveyance canal system was completed in 2004. Construction is under way on water control and treatment facilities in the western portion of Big Cypress Reservation.

Phase II of this project has been divided into four basins. The USACE completed construction of the largest basin, Basin 1, in August 2008 and was transferred for operations and maintenance in February 2010. Permeability rates necessitated design modifications for the other three basins. The contract for Basin 4 construction will be awarded later in 2010. The two remaining construction features, Basin 2 and Basin 3, are scheduled for construction award in 2011 pending funding.

Projected Benefits: Should improve the quality of agricultural water runoff within the reservation, restore storage capacity, and return native vegetation.

IFP Start Date: 1997

Current Estimated Completion Date: 2013 for all basins (Basin 1 is complete).

Original Estimated Cost: \$75.3M (1996)

2009 IFP Estimated Cost: \$60M

Southern CREW Project Additions & Imperial River Flow Way

Status: This project aims to reestablish more natural flow patterns to 4,100 acres in the Southern Corkscrew Regional Ecosystem Watershed (CREW) to improve and restore the hydrology and ecology of the project area. Land acquisition has been accomplished with state and federal cost-sharing. Due to escalating land costs and the difficulty in restoring hydrology in the areas south of the Kehl Canal, the SFWMD governing board approved changes to the project footprint in March 2009, removing the southern half of Sections 32 and 33 that are south of the Kehl Canal. The SFWMD continues to acquire land for this smaller footprint and construct the project.

Observed Benefits: Removal of exotic species, primarily *Melaleuca* trees, on more than 2,560 acres has occurred. Two miles of canals have been plugged and associated berms breached and two miles of dirt roads degraded to restore sheet flow in Section 25, restoring hydropatterns on approximately 640 acres of wetlands.

IFP Start Date: 1995

Current Estimated Completion Date: 2015

Yellow Book Original Estimated Cost: \$33.5M (\$3.4M Construction and \$30.1M Real Estate)

2009 IFP Estimated Cost: \$33.3M

Lake Okeechobee Water Retention & Phosphorus Removal

Status: Construction of two new stormwater treatment areas within the Taylor Creek/Nubbin Slough Basin was physically complete September 2006. The interim construction and testing phase, begun in 2007, is still in progress because of low water. After a pipe leak during a routine test in 2008, the project delivery team (PDT) is determining the responsible party for cost of reparations. Transfer of the project to the sponsor is pending resolution of all warranty issues.

Projected Benefits: To improve the quality of water flowing into Lake Okeechobee.

IFP Start Date: 1997

IFP Completion Date:

Construction complete: 2006

Testing complete; transfer to sponsor: TBD

2009 IFP Cost: \$22.35M

Ten Mile Creek Water Preserve Area

Status: Construction of an above-ground reservoir, pump station, and gated water-level control structure was complete in 2006. Since that time, interim operations, testing, and monitoring have been underway by the SFWMD and USACE in accordance with the water quality permit and Project Cooperation Agreement. During the process to transfer the project to the SFWMD for full operations, the USACE and SFWMD immediately began identifying all concerns and planning a course of action toward remediation. The additional project needs that have been identified have significant associated costs. In June 2009 the SFWMD transferred responsibility for the Ten Mile Creek project to the USACE, which has placed the facility in a passive operating state. Due to limitations on funding, reauthorization will likely be required to proceed.

Projected Benefits: Will provide 6,000 acre-feet of seasonal or temporary storage of stormwater from the Ten Mile Creek Basin on 526 acres of land, which will moderate high-volume freshwater flows and salinity fluctuations in the St.

Lucie Estuary and reduce sediment and nutrient loads to benefit 2,740 acres of estuarine habitat.

IFP Start Date: 1997

IFP Completion Date: TBD

2009 IFP Cost: \$50M (\$43.9M appropriated thru FY2009)

Lake Trafford Restoration

Status: The in-lake portion of dredging was completed by spring of 2006. The second phase of construction and muck removal should have been completed by December 2007, but dredging was delayed due to dry weather and low water. The uncompleted second phase was re-initiated in the spring of 2009 as Phase III, and included dredging the uncompleted littoral zones and deeper portions of the lake. This work is expected to be complete in the first quarter of 2011. The containment facility and much of the dredging have been completed as of early 2008.

Observed and Projected Benefits: Approximately 3 million cubic yards of organic sediments that blanketed the bottom of the lake were removed. Expectations include improving water quality, reestablishing native vegetation, and improving subsequent flows to Corkscrew Swamp Sanctuary and the Florida Panther National Wildlife Refuge. Lake monitoring by the local university has identified significant improvement in the quality of the lake from Phase I and Phase II dredging.

IFP Start Date: 1999

Current Estimated Completion Date: 2011

Yellow Book Original Estimated Cost: \$15.4M

2009 IFP Estimated Cost: \$35.2M

SOURCES: SFERTF (2007a; 2009b); SFWMD (2007); USACE (2007c); Williams (2008); <http://www.saj.usace.army.mil/projects/index.html>, D. Tipple, USACE, personal communication, 2010, L. Gerry, SFWMD, personal communication, 2010.

Appendix D

Regulation Schedule for WCA-3A

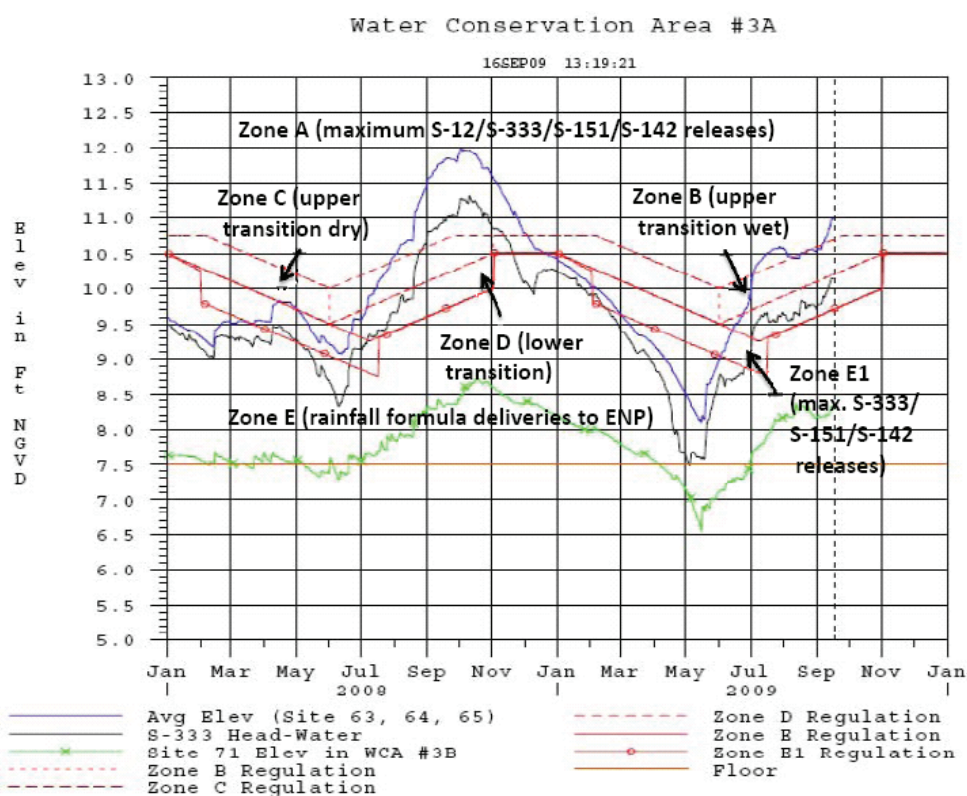

FIGURE D-1 Regulation schedule under the Interim Operational Plan (IOP) for managing water levels in WCA-3A.

SOURCE: http://my.sfwmd.gov/portal/page/portal/pg_grp_sfwmd_era/portlet_archives_meetings_subtabs/toc_archives/archives/2004_08_26/wca_schedules_082604.pdf.

TABLE D-1 WCA-3A Regulation Schedule Structure Discharge Rules

WCA-3A Regulation Schedule Structure Discharge Rules

ZONE	S-12	S-333	S-151	S-343A&B, S-344
Zone A	Open full when permitted, subject to conditions of note 1 below. Zone A is the flood storage pool for WCA-3A, water levels may require the opening of S-12C, S-12B, and/or S-12A during the period 1 Nov – 15 July to avoid an unacceptable risk of failure of WCA-3A levees and structures.	See note 2 and 3 below. Make maximum allowable discharge subject to downstream conditions.	See note 3 below. Maximum allowable discharge when WCA-3B stage is below 8.5 ft-NGVD.	No discharges from 1 Nov – 15 Jul, unless the FWS has determined that nesting for the CSSS sub-population A has ended. If non-nesting season, then make maximum allowable discharges if downstream conditions permit.
Zone B	Discharge 45% of the computed flow for Shark River Slough. From 1 Jun – 15 July, discharges are limited to S-12D, unless the FWS has determined that nesting for the CSSS sub-population A has ended. If S-333 is closed or discharging less than 28% of computed flow for Shark River Slough, S-12 must discharge at least 73% and up to 100% of the computed flow for Shark River Slough, if capacity is available.	See note 2 and 3 below. Discharge 55% of the computed flow for Shark River Slough when permitted by downstream conditions.	See note 3 below. Maximum allowable discharge when WCA-3B stage is below 8.5 ft-NGVD.	Closed from 1 Jun through 15 July, or until the FWS has determined that nesting for the CSSS sub-population A has ended. Otherwise, normally closed in this zone, unless water is needed for environmental reasons.
Zone C	Discharge 45% of the computed flow for Shark River Slough amount. If S-333 is closed or reduced in flow, S-12 can discharge up to 100% of the computed flow for Shark River Slough, if desired by ENP, subject to conditions in note 1 below.	See note 2 and 3 below. Discharge 55% of the computed flow for Shark River Slough when permitted by downstream conditions.	See note 3 below. Maximum allowable discharge when WCA-3B stage is below 8.5 ft-NGVD.	No discharges from 1 Nov – 1 Jun, unless the FWS has determined that nesting for the CSSS sub-population A has ended, then make maximum allowable discharges if no downstream problems.
Zone D	Discharge 45% of the computed flow for Shark River Slough. From 1 Jun – 15 July, discharges are limited to S-12D, unless the FWS has determined that nesting for the CSSS sub-population A has ended. If S-333 is closed or discharging less than 28% of computed flow for Shark River Slough, S-12 must discharge at least 73% and up to 100% of the computed flow for Shark River Slough, if capacity is available.	See note 2 and 3 below. Discharge 55% of the computed flow for Shark River Slough when permitted by downstream conditions.	See note 3 below.	Closed from 1 Jun through 15 July, or until the FWS has determined that nesting for the CSSS sub-population A has ended, S-343A&B, S-344. Otherwise, normally closed in this zone, unless water is needed for environmental reasons.
Zone E	Discharge 45% of the computed flow for Shark River Slough subject to note 1 below. The L-67A Borrow Canal stage should not be drawn down below 7.5 ft-NGVD unless water is supplied from another source.	See note 2 and 3 below. Discharge 55% of the computed flow for Shark River Slough when permitted by downstream conditions. The L-67A Borrow Canal stage should not be drawn down below 7.5 ft-NGVD unless water is supplied from another source.	See note 3 below. The L-67A Borrow Canal stage should not be drawn down below 7.5 ft-NGVD unless water is supplied from another source.	Closed, unless water is needed for environmental reasons. The L-67A Borrow Canal stage should not be drawn down below 7.5 ft-NGVD unless water is supplied from another source.
Zone E1	Discharge 45% of the computed flow for Shark River Slough. From 1 Feb – 15 July, discharges are limited to S-12D, unless the FWS has determined that nesting for the CSSS sub-population A has ended. Revert to Zone E rules if the FWS has determined that nesting for the CSSS sub-population A has ended, or if the headwater at S-333 falls below 8.25 ft-NGVD.	See note 2 and 3 below. Make maximum practicable releases at S-142, S-151, S-31, S-337, S-335, S-333, S-359A&B and S-334, subject to downstream constraints. If the headwater at S-333 falls below 8.25 ft-NGVD, then revert to Zone E rules.	See note 3 below. Maximum allowable discharge when WCA-3B stage is below 8.5 ft-NGVD.	Closed during period 1 Nov through 15 July or until the FWS has determined that nesting for the CSSS sub-population A has ended. If the headwater at S-333 falls below 8.25 ft-NGVD, then revert to Zone E rules.

Notes:

1. For the S-12 Structure in Zone A, C, E, and E1: From 1 Nov – 31 Dec, discharges are limited to S-12B, C, and/or D. From 1 Jan – 31 Jan, discharges are limited to S-12C and/or D. From 1 Feb – 15 July, discharges are limited to S-12D, unless the FWS has determined that nesting for the CSSS sub-population A has ended.
2. If G-3273 is above 6.8 ft-NGVD, no discharges to Northeast Shark River Slough are permitted. However, S-333 may discharge up to maximum capacity provided that water can be discharge via S-334 to the South Dade Conveyance system subject to available capacity.
3. Make water supply discharges to the East Coast and ENP-South Dade Conveyance System as needed.

SOURCE: http://mysfwmd.gov/portal/page/portal/pg_grp_stfwd_md_era/portlet_archives_meetings_subtabs/toc_archives/archives/2004_08_26/wca_schedules_082604.pdf.

E

Water Science and Technology Board Board on Environmental Studies and Toxicology

WATER SCIENCE AND TECHNOLOGY BOARD

DONALD I. SIEGEL, *Chair*, Syracuse University, New York
LISA ALVAREZ-COHEN, University of California, Berkeley
YU-PING CHIN, The Ohio State University, Columbus
OTTO C. DOERING, Purdue University, West Lafayette
GERALD E. GALLOWAY, University of Maryland, College Park
GEORGE R. HALLBERG, The Cadmus Group, Inc., Waltham, Massachusetts
KENNETH R. HERD, Southwest Florida Water Management District,
Brooksville
GEORGE M. HORNBERGER, Vanderbilt University, Nashville
KIMBERLY L. JONES, Howard University, Washington, DC
MICHAEL J. MCGUIRE, Michael J. McGuire, Inc., Santa Monica, California
DAVID H. MOREAU, University of North Carolina, Chapel Hill
DENNIS D. MURPHY, University of Nevada, Reno
MARYLYNN V. YATES, University of California, Riverside

Staff

STEPHEN D. PARKER, Director
JEFFREY W. JACOBS, Scholar
LAURA J. EHLERS, Senior Program Officer
STEPHANIE E. JOHNSON, Senior Program Officer
LAURA E. HELSABECK, Program Officer
M. JEANNE AQUILINO, Financial and Administrative Associate
ELLEN A. DE GUZMAN, Senior Program Associate
ANITA A. HALL, Senior Program Associate
MICHAEL J. STOEVER, Research Associate
SARAH E. BRENNAN, Program Assistant

BOARD ON ENVIRONMENTAL STUDIES AND TOXICOLOGY

ROGENE F. HENDERSON, *Chair*, Lovelace Respiratory Research Institute, Albuquerque, NM

RAMON ALVAREZ, Environmental Defense Fund, Austin, TX

TINA BAHADORI, American Chemistry Council, Arlington, VA

MICHAEL J. BRADLEY, M.J. Bradley & Associates, Concord, MA

DALLAS BURTRAW, Resources for the Future, Washington, DC

JAMES S. BUS, Dow Chemical Company, Midland, MI

JONATHON Z. CANNON, University of Virginia, Charlottesville

GAIL CHARNLEY, HealthRisk Strategies, Washington, DC

RUTH DEFRIES, Columbia University, New York, NY

RICHARD A. DENISON, Environmental Defense Fund, Washington, DC

H. CHRISTOPHER FREY, North Carolina State University, Raleigh

J. PAUL GILMAN, Covanta Energy Corporation, Fairfield, NJ

RICHARD M. GOLD, Holland & Knight, LLP, Washington, DC

LYNN R. GOLDMAN, Johns Hopkins University, Baltimore, MD

JUDITH A. GRAHAM (retired), Pittsboro, NC

HOWARD HU, University of Michigan, Ann Arbor

ROGER E. KASPERSON, Clark University, Worcester, MA

TERRY L. MEDLEY, E. I. du Pont de Nemours & Company, Wilmington, DE

JANA MILFORD, University of Colorado at Boulder, Boulder

DANNY D. REIBLE, University of Texas, Austin

JOSEPH V. RODRICKS, ENVIRON International Corporation, Arlington, VA

ROBERT F. SAWYER, University of California, Berkeley

KIMBERLY M. THOMPSON, Harvard School of Public Health, Boston, MA

MARK J. UTELL, University of Rochester Medical Center, Rochester, NY

Senior Staff

JAMES J. REISA, Director

DAVID J. POLICANSKY, Scholar

RAYMOND A. WASSEL, Senior Program Officer for Environmental Studies

SUSAN N.J. MARTEL, Senior Program Officer for Toxicology

ELLEN K. MANTUS, Senior Program Officer for Risk Analysis

EILEEN N. ABT, Senior Program Officer

RUTH E. CROSSGROVE, Senior Editor

MISADA KARALIC-LONCAREVIC, Manager, Technical Information Center

RADIAH ROSE, Manager, Editorial Projects

F

Biographical Sketches of Committee Members and Staff

Frank W. Davis, *Chair*, is professor at the Bren School of Environmental Science & Management at the University of California, Santa Barbara. His research interests are in landscape ecology and conservation planning. Dr. Davis' current research focuses on the landscape ecology of California plant communities; the design and monitoring of protected-area networks; multi-objective planning tools for rangeland and farmland conservation; and the biological implications of regional climate change in the western United States. He is a fellow of the American Association for the Advancement of Science, a fellow in the Aldo Leopold Leadership Program, and a trustee of the Nature Conservancy of California. Dr. Davis has served on several National Research Council (NRC) committees, starting with the Committee on the Formation of the National Biological Survey in 1993. He served from 1999 to 2004 on the NRC's Committee on the Restoration of the Greater Everglades Ecosystem and since 2006 on the Committee on Independent Scientific Review of Everglades Restoration Progress. He earned a B.A. in biology from Williams College in 1975 and a Ph.D. in geography and environmental engineering from Johns Hopkins University in 1982.

Steven R. Beissinger holds the A. Starker Leopold Chair of Wildlife Biology and is a professor of conservation biology in the Department of Environmental Science, Policy, and Management at the University of California, Berkeley. He also serves as chair of the Ecosystem Sciences Division and the department. Dr. Beissinger conducts research on conservation biology, behavioral ecology, and population biology. His research primarily focuses on birds but has also included work with plants, mammals, and aquatic invertebrates. Dr. Beissinger's current work focuses mainly on (1) field studies of the ecology, demography, and monitoring of endangered or exploited species; (2) demographic models of population viability and recovery; and (3) field studies of parental care strategies and mating systems. He has worked extensively with the U.S. Fish and Wildlife Service, U.S. National Park Service, U.S. Forest Service, and state agencies as

a member of federal endangered recovery teams, as a contractor to conduct research on endangered species and to develop regional monitoring plans, and as a training instructor. He served on the second Committee on Independent Scientific Review of Everglades Restoration Progress. Dr. Beissinger earned his B.S. and M.S. in zoology at Miami University and his Ph.D. in natural resource ecology at the University of Michigan.

William G. Boggess is professor and head of the Department of Agricultural and Resource Economics at Oregon State University (OSU). He also serves as the president of the OSU Faculty Senate. Prior to joining OSU, Dr. Boggess spent 16 years on the faculty at the University of Florida in the Food and Resource Economics Department where he was involved with Everglades work. His research interests include interactions between agriculture and the environment (e.g., water allocation, groundwater contamination, surface-water pollution, sustainable systems, water and environmental policy); economic dimensions and indicators of ecosystem health; and applications of real options to environmental and natural resources. Dr. Boggess currently serves on the Oregon Governor's Council of Economic Advisors, the Board of Directors of the American Agricultural Economics Association, and is the immediate past-chair of the Food Alliance. He also recently served on the State of Oregon Environment Report Science Panel and has been active in the design and assessment of the Oregon Conservation Reserve Enhancement Program. Dr. Boggess served as a member of the NRC Committee on the Use of Treated Municipal Wastewater Effluents and Sludge in the Production of Crops for Human Consumption, and on the second Committee on Independent Scientific Review of Everglades Restoration Progress. He received his Ph.D. from Iowa State University in 1979.

Charles T. Driscoll (NAE) is university professor in the Department of Civil and Environmental Engineering at Syracuse University where he also serves as the director of the Center for Environmental Systems Engineering. His teaching and research interests are in the area of environmental chemistry, biogeochemistry, and environmental quality modeling. A principal research focus has been the response of forest, aquatic, and coastal ecosystems to disturbance, including air pollution, land use change, and elevated inputs of nutrients and mercury. Dr. Driscoll is currently the principal investigator of the National Science Foundation's Long Term Ecological Research Network's project at the Hubbard Brook Experimental Forest in New Hampshire. He is a member of the National Academy of Engineering and was a member of the NRC's Panel on Process of Lake Acidification, the Committee on the Collaborative Large-scale Engineering Analysis Network for Environmental Research (CLEANER), and the second Committee on Independent Scientific Review of Everglades Restoration Progress.

Dr. Driscoll received his B.S. in civil engineering from the University of Maine and his M.S. and Ph.D. in environmental engineering from Cornell University.

Joan G. Ehrenfeld is a professor in the Department of Ecology, Evolution, and Natural Resources at Rutgers University and served as the director of the New Jersey Water Resources Research Institute, a federally funded program of water-related research and outreach, from 1990 until 2010. Her research is in the area of wetland ecology and ecosystems ecology and focuses on plant-soil interactions. Dr. Ehrenfeld's current research includes studies of the interactions of exotic invasive plants and forest soils, nitrogen cycling in forested wetlands affected by urbanization, the role of wetland diversity in the ecology of West Nile Virus, carbon accumulation in wetlands, and connectivity along urban rivers. Dr. Ehrenfeld served as a member of the Committee on Assessment of Water Resources Research, the second Committee on Independent Scientific Review of Everglades Restoration Progress, and two terms on the Water Science and Technology Board. She is a fellow of the Society of Wetland Scientists and serves as a member of the Ecological Processes and Effects Committee of the U.S. Environmental Protection Agency Science Advisory Board and several New Jersey state advisory boards. She received her B.A. in biology from Columbia University, her M.A. in biology from Harvard University, and her Ph.D. in biology from City University of New York.

William L. Graf is Foundation University Professor and professor and chair of the Department of Geography at the University of South Carolina. His expertise is in fluvial geomorphology and hydrology, as well as policy for public land and water. Dr. Graf's research and teaching have focused on river-channel change, human impacts on river processes, morphology, and ecology, along with contaminant transport and storage in river systems. His present work emphasizes the downstream effects of dams on rivers. In the arena of public policy, he has emphasized the interaction of science and decision making, and the resolution of conflicts among economic development, historical preservation, and environmental restoration for rivers. Dr. Graf has served as member of the NRC's Water Science and Technology Board and Board on Earth Sciences and Resources, the Panel to Review the Critical Ecosystem Studies Initiative, the Committee on Restoration of the Greater Everglades Ecosystem, and as a member of the first and chair of the second Committee on Independent Scientific Review of Everglades Restoration Progress. He is also a national associate of the National Academies. Dr. Graf earned a Ph.D. from the University of Wisconsin, Madison, in 1974.

Wendy D. Graham is the Carl S. Swisher Eminent Scholar in Water Resources in the Department of Agricultural and Biological Engineering at the University

of Florida and director of the University of Florida Water Institute. Her research is focused on coupled hydrologic-water quality-ecosystem modeling; water resources evaluation and remediation; evaluation of impacts of agricultural production on surface- and groundwater quality; and development of hydrologic indicators of ecosystem status. She has previous NRC committee experience, having served on the Committee on Seeing Into the Earth: Non-Invasive Techniques for Characterization of the Shallow Subsurface for Environmental Engineering Applications. Dr. Graham received her B.S.E. in environmental engineering from the University of Florida and her Ph.D. in civil engineering from the Massachusetts Institute of Technology.

Chris T. Hendrickson is the Duquesne Light Company Professor of Engineering and codirector of the Green Design Institute at Carnegie Mellon University. His research, teaching, and consulting are in the general area of engineering planning and management, including design for the environment, system performance, project management, finance, and computer applications. Dr. Hendrickson's current research projects include environmental life-cycle assessment methodology development, heavy metal material flow analysis, infrastructure requirements for alternative transportation fuels, and sustainable infrastructure. He has served on several NRC committees including the first and second Committees on Independent Scientific Review of Everglades Restoration Progress, the Committee on Assessing the Results of External Independent Reviews for U.S. Department of Energy Projects, and the Committee for Review of the Project Management Practices Employed on the Boston Central Artery ("Big Dig") Project. Dr. Hendrickson holds B.S. and M.S. degrees from Stanford University, a master of philosophy degree in economics from Oxford University, and a Ph.D. from the Massachusetts Institute of Technology.

William P. Horn is a partner in the law firm of Birch, Horton, Bittner and Cherot in Washington, DC. Prior to entering private practice, Mr. Horn served in a variety of congressional and executive posts including as assistant secretary of the interior for fish, wildlife, and parks, and as deputy under secretary of the interior with responsibilities for western water rights negotiations, international fishery negotiations, and Alaska programs. He specializes in natural resources law and has expertise in land acquisition and appraisal, wildlife law including the Endangered Species Act and the Migratory Bird Treaty Act, National Park concessions, Forest Service matters, recreational permits, and other public land and related regulatory matters. Mr. Horn served on the second Committee on Independent Scientific Review of Everglades Restoration Progress and is a member of the Board on Environmental Studies and Toxicology, and the Bar of the District of Columbia. Mr. Horn is a recipient of the Department of the Interior's Outstand-

ing Services Award and the International Academy of Trial Lawyers Advocacy Award. He earned his J.D. in 1983 from American University.

David H. Moreau is chair of the curriculum and research professor in the Department of City and Regional Planning at the University of North Carolina at Chapel Hill. His research interests include analysis, planning, financing, and evaluation of water resource and related environmental programs. Dr. Moreau is engaged in water resources planning at the local, state, and national levels. He has served on several NRC committees, including the Committee on New Orleans Regional Hurricane Protection Projects, the Committee to Review the Lake Ontario-St. Lawrence River Studies, and the second Committee on Independent Scientific Review of Everglades Restoration Progress, and he is a current member of the Water Science and Technology Board. Dr. Moreau serves as chairman of the North Carolina Environmental Management Commission, the state's regulatory commission for water quality, air quality, and water allocation. He received his B.S. and M.S. from Mississippi State University and North Carolina State University, respectively, and his Ph.D. degree from Harvard University.

K. Ramesh Reddy is graduate research professor and chair of the Department of Soil and Water Science at the University of Florida. His research areas include soil quality, ecological indicators, wetlands, and aquatic systems. Dr. Reddy investigates biogeochemical cycling of nutrients (including redox-related processes) in natural ecosystems, including wetlands, shallow lakes, estuaries, and constructed wetlands and develops biogeochemical indicators to evaluate changes in ecosystem functions. He is a member of the U.S. National Committee for Soil Sciences in the National Academy's Policy and Global Affairs Division. He served as a member of the second Committee on Independent Scientific Review of Everglades Restoration Progress. Dr. Reddy earned his Ph.D. in agronomy and soil science from Louisiana State University and Agricultural and Mechanical College in 1976.

R. Wayne Skaggs (NAE) is the William Neal Reynolds Distinguished University Professor in the Department of Biological and Agricultural Engineering at North Carolina State University. His primary areas of interest are in the field of agricultural drainage, water management, drainage water quality, and wetland hydrology. He has developed the DRAINMOD suite of models to describe the hydrology of poorly drained soils (including wetlands) and the performance of drainage, controlled drainage and subirrigation systems on those soils; to predict the effect of drainage and related water management system design on losses of nitrogen, sediment, and phosphorus from agricultural fields; to consider the hydrology of watershed-scale rather than field-scale systems; to quantify the

hydrology of forested watersheds; and to predict soil salinity and the effect of water management practices on it. Dr. Skaggs is a member of the National Academy of Engineering and is a past president of the American Society of Agricultural Engineers. He received his B.S. and M.S. in agricultural engineering from the University of Kentucky and his Ph.D. in agricultural engineering from Purdue University, and he is a certified professional engineer.

Robert R. Twilley is the director of the wetland biogeochemistry program and professor in the Department of Oceanography and Coastal Science at Louisiana State University. His primary expertise is in systems ecology and biogeochemistry of coastal wetlands both in the Gulf of Mexico and throughout Latin America, and through this research he has tried to develop fundamentals of ecosystem science by describing biogeochemical processes (denitrification, nutrient burial, benthic nutrient fluxes) that determine the function of coastal ecosystems as either a source or sink of primary nutrients to near shore environments. Dr. Twilley has also spent a large part of his career determining the role of mangroves in the fate of carbon and nutrients in tropical estuaries. His current research focuses on developing ecosystem models, both conceptual and simulation, to forecast the rehabilitation of coastal and wetland ecosystems. He is a member of the Louisiana Framework Development Team that is developing a comprehensive restoration plan for the Louisiana Coastal Area and is active in the Estuarine Research Federation. He was also the co-author of a 2002 report by the Pew Center for Global Climate Change titled *Coastal and Marine Ecosystems and Global Climate Change*. Dr. Twilley received his B.S. and M.S. in biology from East Carolina University and his Ph.D. in plant ecology/systems ecology from the University of Florida.

STAFF

Stephanie E. Johnson, *study director*, is a senior program officer with the Water Science and Technology Board. Since joining the NRC in 2002, she has served as study director for seven committees, including the Panel to Review the Critical Ecosystem Studies Initiative and the Committee on Advancing Desalination Technology Research. She has also worked on NRC studies on contaminant source remediation, the disposal of coal combustion wastes, and water security. Dr. Johnson received her B.A. from Vanderbilt University in chemistry and geology, and her M.S. and Ph.D. in environmental sciences from the University of Virginia on the subject of pesticide transport and microbial bioavailability in soils.

David J. Policansky is a scholar in the Board on Environmental Studies and Toxicology. He earned a Ph.D. in biology from the University of Oregon. Dr.

Policansky has directed approximately 35 NRC studies, and his areas of expertise include genetics; evolution; ecology, including fishery biology; natural resource management; and the use of science in policy making.

Michael J. Stoever is a research associate with the Water Science and Technology Board. He has worked on a number of studies including Desalination: A National Perspective, the Water Implications of Biofuels Production in the United States, and the Committee on Louisiana Coastal Protection and Restoration. He has also worked on NRC studies on the WATERS Network, the effect of water withdrawals on the St. Johns River, and Chesapeake Bay restoration. Mr. Stoever received his B.A. degree in political science from The Richard Stockton College of New Jersey in Pomona, New Jersey.

