

## Centerline Rumble Strips

### DETAILS

---

63 pages | | PAPERBACK

ISBN 978-0-309-42666-4 | DOI 10.17226/23327

### AUTHORS

---

BUY THIS BOOK

FIND RELATED TITLES

Visit the National Academies Press at [NAP.edu](http://NAP.edu) and login or register to get:

---

- Access to free PDF downloads of thousands of scientific reports
- 10% off the price of print titles
- Email or social media notifications of new titles related to your interests
- Special offers and discounts



Distribution, posting, or copying of this PDF is strictly prohibited without written permission of the National Academies Press. (Request Permission) Unless otherwise indicated, all materials in this PDF are copyrighted by the National Academy of Sciences.

Copyright © National Academy of Sciences. All rights reserved.

---

---

**NCHRP SYNTHESIS 339**

---

---

**Centerline Rumble Strips**

***A Synthesis of Highway Practice***

**CONSULTANTS**

EUGENE R. RUSSELL

and

MARGARET J. RYS

Kansas State University

**TOPIC PANEL**

RICHARD A. CUNARD, *Transportation Research Board*

RANDALL GRUNDEN, *Delaware Department of Transportation*

BILL KENNY, *Alberta Transportation*

RONALD LIPPS, *Maryland State Highway Administration*

JAY MEYER, *Wyoming Department of Transportation*

MARTIN PIETRUCHA, *Penn State University*

RICHARD A. RETTING, *Insurance Institute for Highway Safety*

MANU SHAH, *Maryland State Highway Administration (retired)*

BRIAN STANFORD, *Texas Department of Transportation*

A.J. NEDZESKY, *Federal Highway Administration (Liaison)*

RICHARD POWERS, *Federal Highway Administration (Liaison)*

**SUBJECT AREAS**

Highway and Facility Design; Pavement Design, Management, and Performance;  
Highway Operation, Capacity, and Traffic Control; and Safety and Human Performance

---

Research Sponsored by the American Association of State Highway and Transportation Officials  
in Cooperation with the Federal Highway Administration

---

**TRANSPORTATION RESEARCH BOARD**

WASHINGTON, D.C.

2005

[www.TRB.org](http://www.TRB.org)

## NATIONAL COOPERATIVE HIGHWAY RESEARCH PROGRAM

Systematic, well-designed research provides the most effective approach to the solution of many problems facing highway administrators and engineers. Often, highway problems are of local interest and can best be studied by highway departments individually or in cooperation with their state universities and others. However, the accelerating growth of highway transportation develops increasingly complex problems of wide interest to highway authorities. These problems are best studied through a coordinated program of cooperative research.

In recognition of these needs, the highway administrators of the American Association of State Highway and Transportation Officials initiated in 1962 an objective national highway research program employing modern scientific techniques. This program is supported on a continuing basis by funds from participating member states of the Association and it receives the full cooperation and support of the Federal Highway Administration, United States Department of Transportation.

The Transportation Research Board of the National Academies was requested by the Association to administer the research program because of the Board's recognized objectivity and understanding of modern research practices. The Board is uniquely suited for this purpose as it maintains an extensive committee structure from which authorities on any highway transportation subject may be drawn; it possesses avenues of communications and cooperation with federal, state, and local governmental agencies, universities, and industry; its relationship to the National Research Council is an insurance of objectivity; it maintains a full-time research correlation staff of specialists in highway transportation matters to bring the findings of research directly to those who are in a position to use them.

The program is developed on the basis of research needs identified by chief administrators of the highway and transportation departments and by committees of AASHTO. Each year, specific areas of research needs to be included in the program are proposed to the National Research Council and the Board by the American Association of State Highway and Transportation Officials. Research projects to fulfill these needs are defined by the Board, and qualified research agencies are selected from those that have submitted proposals. Administration and surveillance of research contracts are the responsibilities of the National Research Council and the Transportation Research Board.

The needs for highway research are many, and the National Cooperative Highway Research Program can make significant contributions to the solution of highway transportation problems of mutual concern to many responsible groups. The program, however, is intended to complement rather than to substitute for or duplicate other highway research programs.

---

**NOTE: The Transportation Research Board of the National Academies, the National Research Council, the Federal Highway Administration, the American Association of State Highway and Transportation Officials, and the individual states participating in the National Cooperative Highway Research Program do not endorse products or manufacturers. Trade or manufacturers' names appear herein solely because they are considered essential to the object of this report.**

## NCHRP SYNTHESIS 339

Project 20-5 FY 2002 (Topic 34-01)  
ISSN 0547-5570  
ISBN 0-309-07020-1  
Library of Congress Control No. 2004114408

© Transportation Research Board

**Price \$16.00**

### NOTICE

The project that is the subject of this report was a part of the National Cooperative Highway Research Program conducted by the Transportation Research Board with the approval of the Governing Board of the National Research Council. Such approval reflects the Governing Board's judgment that the program concerned is of national importance and appropriate with respect to both the purposes and resources of the National Research Council.

The members of the technical committee selected to monitor this project and to review this report were chosen for recognized scholarly competence and with due consideration for the balance of disciplines appropriate to the project. The opinions and conclusions expressed or implied are those of the research agency that performed the research, and, while they have been accepted as appropriate by the technical committee, they are not necessarily those of the Transportation Research Board, the National Research Council, the American Association of State Highway and Transportation Officials, or the Federal Highway Administration, U.S. Department of Transportation.

Each report is reviewed and accepted for publication by the technical committee according to procedures established and monitored by the Transportation Research Board Executive Committee and the Governing Board of the National Research Council.

*Published reports of the*

### **NATIONAL COOPERATIVE HIGHWAY RESEARCH PROGRAM**

*are available from:*

Transportation Research Board  
Business Office  
500 Fifth Street, NW  
Washington, DC 20001

*and can be ordered through the Internet at:*

<http://www.national-academies.org/trb/bookstore>

Printed in the United States of America

# THE NATIONAL ACADEMIES

## *Advisers to the Nation on Science, Engineering, and Medicine*

The **National Academy of Sciences** is a private, nonprofit, self-perpetuating society of distinguished scholars engaged in scientific and engineering research, dedicated to the furtherance of science and technology and to their use for the general welfare. On the authority of the charter granted to it by the Congress in 1863, the Academy has a mandate that requires it to advise the federal government on scientific and technical matters. Dr. Bruce M. Alberts is president of the National Academy of Sciences.

The **National Academy of Engineering** was established in 1964, under the charter of the National Academy of Sciences, as a parallel organization of outstanding engineers. It is autonomous in its administration and in the selection of its members, sharing with the National Academy of Sciences the responsibility for advising the federal government. The National Academy of Engineering also sponsors engineering programs aimed at meeting national needs, encourages education and research, and recognizes the superior achievements of engineers. Dr. William A. Wulf is president of the National Academy of Engineering.

The **Institute of Medicine** was established in 1970 by the National Academy of Sciences to secure the services of eminent members of appropriate professions in the examination of policy matters pertaining to the health of the public. The Institute acts under the responsibility given to the National Academy of Sciences by its congressional charter to be an adviser to the federal government and, on its own initiative, to identify issues of medical care, research, and education. Dr. Harvey V. Fineberg is president of the Institute of Medicine.

The **National Research Council** was organized by the National Academy of Sciences in 1916 to associate the broad community of science and technology with the Academy's purposes of furthering knowledge and advising the federal government. Functioning in accordance with general policies determined by the Academy, the Council has become the principal operating agency of both the National Academy of Sciences and the National Academy of Engineering in providing services to the government, the public, and the scientific and engineering communities. The Council is administered jointly by both the Academies and the Institute of Medicine. Dr. Bruce M. Alberts and Dr. William A. Wulf are chair and vice chair, respectively, of the National Research Council.

The **Transportation Research Board** is a division of the National Research Council, which serves the National Academy of Sciences and the National Academy of Engineering. The Board's mission is to promote innovation and progress in transportation through research. In an objective and interdisciplinary setting, the Board facilitates the sharing of information on transportation practice and policy by researchers and practitioners; stimulates research and offers research management services that promote technical excellence; provides expert advice on transportation policy and programs; and disseminates research results broadly and encourages their implementation. The Board's varied activities annually engage more than 5,000 engineers, scientists, and other transportation researchers and practitioners from the public and private sectors and academia, all of whom contribute their expertise in the public interest. The program is supported by state transportation departments, federal agencies including the component administrations of the U.S. Department of Transportation, and other organizations and individuals interested in the development of transportation. [www.TRB.org](http://www.TRB.org)

[www.national-academies.org](http://www.national-academies.org)

**NCHRP COMMITTEE FOR PROJECT 20-5**

**CHAIR**

GARY D. TAYLOR, *CTE Engineers*

**MEMBERS**

THOMAS R. BOHUSLAV, *Texas DOT*

DONN E. HANCHER, *University of Kentucky*

DWIGHT HORNE, *Federal Highway Administration*

YSELA LLORT, *Florida DOT*

WESLEY S.C. LUM, *California DOT*

JAMES W. MARCH, *Federal Highway Administration*

JOHN M. MASON, JR., *Pennsylvania State University*

LARRY VELASQUEZ, *New Mexico DOT*

PAUL T. WELLS, *New York State DOT*

**FHWA LIAISON**

WILLIAM ZACCAGNINO

**TRB LIAISON**

MARK R. NORMAN

**COOPERATIVE RESEARCH PROGRAM STAFF**

ROBERT J. REILLY, *Director, Cooperative Research Programs*

CRAWFORD F. JENCKS, *Manager, NCHRP*

EILEEN P. DELANEY, *Director of Publications*

**NCHRP SYNTHESIS STAFF**

STEPHEN R. GODWIN, *Director for Studies and Information Services*

JON WILLIAMS, *Manager, Synthesis Studies*

DONNA L. VLASAK, *Senior Program Officer*

DON TIPPMAN, *Editor*

CHERYL KEITH, *Senior Secretary*

## **FOREWORD**

*By Staff  
Transportation  
Research Board*

Highway administrators, engineers, and researchers often face problems for which information already exists, either in documented form or as undocumented experience and practice. This information may be fragmented, scattered, and unevaluated. As a consequence, full knowledge of what has been learned about a problem may not be brought to bear on its solution. Costly research findings may go unused, valuable experience may be overlooked, and due consideration may not be given to recommended practices for solving or alleviating the problem.

There is information on nearly every subject of concern to highway administrators and engineers. Much of it derives from research or from the work of practitioners faced with problems in their day-to-day work. To provide a systematic means for assembling and evaluating such useful information and to make it available to the entire highway community, the American Association of State Highway and Transportation Officials—through the mechanism of the National Cooperative Highway Research Program—authorized the Transportation Research Board to undertake a continuing study. This study, NCHRP Project 20-5, “Synthesis of Information Related to Highway Problems,” searches out and synthesizes useful knowledge from all available sources and prepares concise, documented reports on specific topics. Reports from this endeavor constitute an NCHRP report series, *Synthesis of Highway Practice*.

This synthesis series reports on current knowledge and practice, in a compact format, without the detailed directions usually found in handbooks or design manuals. Each report in the series provides a compendium of the best knowledge available on those measures found to be the most successful in resolving specific problems.

## **PREFACE**

This report of the Transportation Research Board will be of interest to transportation agencies, as well as to others in the transportation community who are interested in the installation of centerline rumble strips (CLRS). The synthesis was undertaken to address the need for state-of-the-practice information relative to CLRS use and/or design. It summarizes current design practices, installation, configuration, dimensions, and visibility. The synthesis addresses the need for guidance on warrants, benefits, successful practices, and concerns (e.g., external noise and the reduced visibility of centerline striping material). Also addressed are pavement deterioration, ice buildup in the grooves, adverse impact on emergency vehicles, and the effect of CLRS on bicyclists. Particular attention was paid to available before-and-after (CLRS) installation crash data to document the safety aspects of CLRS and the availability of policies, guidelines, warrants, and costs regarding their use and design.

This synthesis report included a review of published literature and unpublished reports on CLRS. In addition, a survey was distributed to all 50 states, the District of Columbia, and 7 Canadian provinces. Discussions with contacts yielded further information. Case studies were undertaken for two representative states that provide overview information about innovative approaches and their results, as well as lessons learned.

A panel of experts in the subject area guided the work of organizing and evaluating the collected data and reviewed the final synthesis report. A consultant was engaged to collect and synthesize the information and to write the report. Both the consultant and the members of the oversight panel are acknowledged on the title page. This synthesis is an immediately useful document that records the practices that were acceptable within the limitations of the knowledge available at the time of its preparation. As progress in research and practice continues, new knowledge will be added to that now at hand.

## CONTENTS

1	SUMMARY
3	CHAPTER ONE INTRODUCTION Statement of the Problem, 3 Scope, 4 Methodology, 4 Organization of the Report, 4
5	CHAPTER TWO LITERATURE REVIEW Published Literature, 5 Unpublished Reports and Materials, 21
28	CHAPTER THREE CASE STUDIES Alaska, 28 Minnesota, 29
33	CHAPTER FOUR DISCUSSION OF SURVEY RESULTS—STATE OF THE PRACTICE E-Mail Survey, 33 Survey Results, 33 Supplementary Survey, 37 Survey Conclusions, 38
40	CHAPTER FIVE KEY ISSUES AND ANALYSIS Centerline Rumble Strip Effectiveness, 40 Extent of Centerline Rumble Strip Use, 40 Compilation of Positive Findings, 40 Compilation of Negative Findings, 40 Relationship of Key Issues to Synthesis Scope, 40
43	CHAPTER SIX CONCLUSIONS AND SUGGESTIONS
44	REFERENCES
45	BIBLIOGRAPHY
46	APPENDIX A SURVEY QUESTIONNAIRE
49	APPENDIX B LIST OF RESPONDENTS
51	APPENDIX C STATE POLICIES, GUIDELINES, AND RELATED DOCUMENTS

# CENTERLINE RUMBLE STRIPS

**SUMMARY** The primary purpose of centerline rumble strips (CLRS) is to warn drivers whose vehicles are crossing centerlines of two-lane, two-way roadways to avoid potential crashes with opposing traffic. Two types of crashes are generally considered correctable by CLRS: head-on and opposite-direction sideswipes, often referred to as cross-over or cross-centerline crashes. A definition proposed by the state of Missouri may be most appropriate: Crashes that qualify as CLRS correctable are any cross-centerline (cross-over) crash that begins with a vehicle encroaching on the opposing lane, excluding any crash that began by running off the road to the right and overcorrecting and any crash that began by a vehicle going out of control owing to water, ice, snow, etc., before crossing the centerline.

Although the use of CLRS has been growing since about 1999, it is clearly still in the experimental stage. Early surveys in 2000 indicated that 20 states and 1 Canadian province had experimental sections of CLRS ranging from a few miles to 15 mi. For this study, 50 states and the District of Columbia were surveyed. Responses were received from 46, for a response rate of 90%. Responses were received from 7 Canadian provinces as well. In the current survey, 22 states and 2 Canadian provinces reported having CLRS, an increase of only 2 states and 1 province; however, the number of lane miles of CLRS has greatly increased, with one state reporting 300 mi. In regard to where they were used, 14 respondents answered that they were used continuously, 4 that they were used only on no-passing sections, 2 that they were used only on curves, and 2 that they were used only on specific sections. It appears that the majority of the 22 states believe that they are an effective safety counter measure to head-on and opposite-direction sideswipe, cross-over crashes. There are indications in survey answers that other states are waiting for more evidence of success before installing CLRS.

According to an Insurance Institute of Highway Safety (IIHS) study, in the United States, crashes on rural roads account for 60% of all fatal crashes. Approximately 90% of these fatal crashes occur on two-lane roads. Vehicles crossing the centerline of two-lane roads and either sideswiping or striking opposing vehicles head on account for 20% of all fatal crashes on these two-lane roads and result in approximately 4,500 annual fatalities.

CLRS primarily address the problem of drowsy or inattentive drivers on two-lane, two-way highways drifting left out of their lane and striking an oncoming vehicle. The most compelling evidence supporting CLRS use is the reduced number of crashes and lives saved. A report by the state by Delaware calculated an impressive benefit–cost ratio of 110 to 1, albeit one based on a single 2.9-mi section and brief before and after periods. Several other states reported significant reductions in overall crashes and/or fatal crashes. A few states reported that the data showed no significant decrease in crashes after the installation of CLRS. Most before-and-after studies are based on very few years of data.

The most reliable evidence of the value of CLRS is a recent study conducted by the IIHS. In this study the researchers collected and analyzed all data in the United States that they considered reliable and, using the Empirical Bayes method and data from 7 states with 210 mi of CLRS, concluded that overall motor vehicle crashes at sites treated with CLRS were reduced by 14%. In addition, it was estimated that injury crashes were reduced by 15%, frontal and opposing-direction sideswipe crashes were reduced by 21%, and front and opposing-direction sideswipe crashes involving injuries were reduced by 25%. When the



crashes were disaggregated into nighttime and daytime crashes, the percent reduction at night was greater than during the day—19% versus 9%—however, the difference was not statistically significant at the 5% level ( $p = 0.096$ ). Data on fatalities were insufficient to draw any conclusions.

Information currently available and the IIHS study lead to the conclusion that installing CLRS reduces cross-over crashes. However, confidence in the quantitative nature of most before-and-after analysis is limited because most CLRS installations have been in place only a short time; more than 1 or 2 years of post-installation data would be desirable. In regard to analyzing crash data, some guidelines or standardization should be developed. It is essential that regression to the mean (explained in chapter one) be considered. It is difficult to compare results analyzed for different time periods and/or collected by different methods. States with CLRS sites in place need to continue monitoring and analyzing the data.

Although the overall conclusion from the currently available material is that CLRS are a low-cost, effective countermeasure for mitigating cross-over crashes on two-lane roadways, there are some concerns. The two concerns most often reported in the survey are external noise and reduced visibility of the centerline striping material (generally paint). However, some respondents commented that the painted stripes over CLRS are more visible during rain. Pavement deterioration, ice buildup in the grooves, and adverse impact on emergency vehicles were also reported; however, these were isolated concerns, with each being expressed by only one or two states. Concerns regarding bicyclists' safety are potentially more serious. Three states (Colorado, Pennsylvania, and Wyoming) indicated negative comments from the bicycling community. The stated concern of bicyclists was that when CLRS are present, motorists do not move over toward or cross the centerline to provide sufficient space when passing bicyclists. This safety concern is given credibility by Penn State University research results that showed that motorists shift their position in the lane away from the centerline in the presence of CLRS; however, no bicycles were present in the study. Colorado research noted that "there could be an increased danger to bicyclists."

One innovative design was uncovered to address the issue of reduced visibility of centerline striping and potential damage to the centerline joint. Minnesota has developed a section for areas with double 4-in. stripes (no-passing zones) that has 6-in. (lateral dimension) rumble strips 2 in. outside of the stripes on each side. The objective is to reduce problems with the visibility of the stripes and possible deterioration of the centerline joint.

Most of the states using CLRS have installed milled CLRS. The length (perpendicular to the centerline) of the CLRS varies from 12 in. to 30 in., with 12 in. and 16 in. being used predominantly. The width (along the centerline) varies from 4 in. to 8 in., with 7 in. used predominantly. The depth of the grooves is commonly one-half inch. The definition of width as the dimension along the centerline and the length as the dimension perpendicular to the centerline is used by most states and throughout this synthesis. (It was noted that several states with CLRS call width the dimension perpendicular to the centerline and length the dimension along the centerline.) Either the continuous or alternating patterns proposed by Kansans' researchers are adequate to create the tactile and auditory response necessary to alert drivers crossing over the centerline. Most of the states did not have to adjust the width of the road because of the CLRS installations. The reduction in drivable area did not create problems in most states.

Four states (California, Oregon, Pennsylvania, and Utah) reported having a policy for the installation of CLRS and included policies or guidelines with their responses. Three other states (Kansas, Kentucky, and Minnesota) and the province of Alberta responded with drawings of installations. At the time of the supplementary survey, Minnesota sent draft guidelines and Missouri sent draft warrants. All of this material is presented in the synthesis or appendices.

An attempt was made to determine if CLRS were used internationally. This was done by a literature search and through personal contacts in England, Europe, and Australia. No indication of any use of CLRS outside of the United States and Canada was found.

## INTRODUCTION

### STATEMENT OF THE PROBLEM

Rural roads account for 60% of all fatal crashes in the United States, with approximately 90% occurring on two-lane roads. Twenty percent of fatal crashes on rural, two-lane roads, with approximately 4,500 annual fatalities, are the result of hitting opposing vehicles in head-on or opposite direction sideswipe crashes, sometimes referred to as cross-over crashes (Suzman 1999). Clearly there is a need for an effective method of keeping the occasionally inattentive drivers in their lanes. The primary purpose of centerline rumble strips (CLRS) is to warn drivers whose vehicles are crossing the centerline of two-lane, two-way roadways to avoid potential crashes with opposing traffic. The noise and vibration generated by the CLRS grooves is intended to alert drivers to take corrective action before leaving their lane and colliding with an oncoming vehicle.

CLRS are patterned after shoulder rumble strips. The use of rumble strips on highway shoulders to warn drivers that they are leaving (or have left) the traveled surface is becoming increasingly popular (Harwood 1993; Harwood 1995; Suzman 1999; Neuman et al. 2003). Currently, shoulder rumble strips are widely used on rural and urban highways throughout the United States as a method to reduce drift-off-the-roadway crashes. Although reports on the effectiveness vary considerably in the literature, Griffith (1999) and Hanley et al. (2000) reported that before-and-after studies with comparison groups show that continuous shoulder rumble strips installed on freeways can reduce single-vehicle, run-off-road crashes by approximately 20%.

CLRS are placed in the center of the roadway, usually on two-lane, two-way rural roads, between opposing lanes of traffic, to alert drivers that they have crossed into the path of oncoming traffic. They have potential to reduce cross-over crashes; for example, head-on and sideswipe crashes. They may also reduce run-off-road (ROR) to the left crashes on two-lane roads. When used in conjunction with shoulder rumble strips, they may reduce drift-out-of-lane crashes, as both the left and right sides of the travel lane are protected.

An article by Morena (2003) primarily addressed shoulder rumble strips on freeways in Michigan. However, some points made in that article also relate to CLRS. For example, researchers studying Michigan drift-off-road crashes found that in nearly half of the crash vehicles (47%) exited

the highway to the left (with 53% to the right), “defying the common perception that this type of incident (drift off road) is primarily a right side crash.” The implication being that left shoulder rumble strips are as important as right shoulder rumble strips. Although not mentioned in the article, it is believed that this would also be true on two-lane roads, and that vehicles drifting left would contact CLRS and potentially be alerted.

According to a 1990 national study, head-on collisions were the cause of approximately 40% of all fatal, multiple-vehicle crashes (Alexander and Garder 1995). This same study showed that more than 86% of fatal head-on collisions on two-lane highways were caused not by a driver attempting to pass another vehicle but rather “typically either by entering a curve at too high a speed or by drifting across the road after falling asleep or being inattentive” (Alexander and Garder 1995).

Statistics from the Fatality Analysis Reporting System (FARS) show that for two-lane, undivided roadways 8,901 crashes (24%) were nonjunction ROR crashes, and the 1999 FARS statistics indicated that 18% of the fatal crashes on these sections were the result of two vehicles colliding head on. In addition, it was reported that

- 75% of head-on crashes occur on rural roads,
- 75% of head-on crashes occur on undivided two-lane roads, and
- 83% of two-lane, undivided road crashes occur on rural roads (Neuman et al. 2003).

Two other points related to two-lane, two-way roads that have implications regarding CLRS are that:

1. Most head-on crashes are likely to result when a driver falls asleep, is distracted, or travels too fast in a curve; and
2. The majority of head-on fatalities on two-lane rural roads are on tangent sections (63% vs. 37%) (Neuman et al. 2003).

Until recently, little has been done to prevent drivers on two-lane, two-way roads from crossing over the highway centerline, where the results of drifting out of the travel lane can be catastrophic because of the possibility of a head-on collision.

Relatively large differences are found in reported results of the effectiveness of rumble strips. Possible reasons for these differences are variations in the quality of the data and the use of different methodologies. As concluded in a recent report on proper statistical methods for analyzing highway safe data, “the level of knowledge of the special methodologies that are required to accommodate the peculiarities of highway safety data is not as high as might be desired” (Persaud 2001).

Most analyses performed to determine the effectiveness of rumble strips—both shoulder and centerline—are before-and-after studies. In the case of CLRS, there are very few years of after data, making it very important that proper methods are used or that conclusions are not based on inadequate data (Persaud 2001). Although most states employ individuals with sufficient statistical knowledge and ability, a recent report that surveyed the state of the practice in this area noted that improvements in the following areas could be made in before-and-after analysis:

- Selection of appropriate comparison groups;
- Specification and interpretation of uncertainty in the results;
- Separation of effects as a result of the measure being evaluated from those resulting from other measures, for example, traffic volume changes, changes in accident reporting practice, and other temporal changes; and
- Use of technique such as Empirical Bayes methodology to account for regression to the mean (RTM) (Persaud 2001).

For some reported before-and-after studies of the effectiveness of CLRS, only 1 or 2 years of before and/or after data were available, making RTM a serious concern. Regardless of whether treatment is initiated on a given section of roadway, there is a high probability that there would have been fewer crashes, if conditions remain about the same.

Readers should keep this in mind when analyzing safety treatments or when reading the results of analysis of the effectiveness of any safety treatment. For a more detailed discussion of proper statistical methods applied to safety analysis, see *NCHRP Synthesis of Highway Practice 295: Statistical Methods in Highway Safety Analysis* (Persaud 2001).

The Insurance Institute for Highway Safety (IIHS) sponsored a study that used all available reliable data in the United States and state-of-the-art statistical techniques to analyze these data. The consultants for this study found that CLRS reduced overall crashes 14%, injury crashes 15%, opposite-

direction crashes by an estimated 21%, and opposite-direction injury crashes by an estimated 25% (Persaud et al. 2003).

## SCOPE

For this synthesis, a search was conducted of the published literature and unpublished reports on CLRS. A survey was distributed to all 50 states and the District of Columbia, in addition to 7 Canadian provinces. Particular attention was paid to available before-and-after (CLRS installation) crash data to document the safety aspects of CLRS and the availability of policy, guidelines, warrants, and costs regarding their use and or design. Case studies were undertaken for two representative states (Alaska and Minnesota). In addition, information on the reported concerns regarding the use of CLRS is included.

## METHODOLOGY

A survey questionnaire was used to document the state of the practice in the state and provincial transportation agencies. Fifty-four responses were received and analyzed and are presented in a matrix of states topics, questions, and results in chapter four. A supplementary survey regarding warrants was sent to all respondents to the initial survey, and these results are also presented in chapter four.

## ORGANIZATION OF THE REPORT

Chapter two contains the results of a literature review consisting of published reports and papers, unpublished reports and material, a summary of completed and ongoing research, and a summary of key points. Chapter three provides a discussion of two case studies including an overview, innovative approaches, and the results and lessons learned. Chapter four presents the survey results, which set forth the state of the practice in the United States and Canada, and a supplementary survey regarding warrants. Chapter five contains a summary of the key issues and analysis of the findings from published and unpublished material reviewed, personal contacts, and case studies separated into warrants, design issues, operational effects, effects on crashes, impacts on bicyclists, maintenance, cost, and other issues. Chapter six contains conclusions and provides suggestions where additional research may be helpful.

Appendix A contains a copy of the survey. Appendix B contains a list of respondents from the states and provinces. Appendix C provides draft policies sent by California, Oregon, and Utah, draft guidelines sent by Pennsylvania and Minnesota, and draft warrants sent by Missouri.

## LITERATURE REVIEW

### PUBLISHED LITERATURE

#### General

The NHTSA estimates that fully “one-third of all traffic fatalities nationwide and two-thirds of traffic fatalities in rural areas” are caused by ROR accidents (Suzman 1999). These crashes occur when drivers veer out of their travel lanes and either off the side of the roadway to the right or into the path of oncoming traffic to the left. ROR crashes in rural locations are of particular concern.

The most common method of keeping drivers in their intended travel lanes, used on nearly all Interstate and secondary highways, is to apply striping with highway paint or other materials. The stripes are either white or yellow in color and contrast highly with the dark gray or black highway surface. White is used to separate lanes of traffic traveling in the same direction, whereas yellow is used to separate lanes traveling in opposing directions. Sometimes, glass beads or other reflective material is added to the striping medium to increase nighttime reflectivity. Painted highway striping is relatively inexpensive to apply and generally does an adequate job of assisting drivers in staying in their lanes. However, because it is purely a visual indicator, its effectiveness is limited primarily to attentive drivers and good environmental conditions; for example, the absence of rain or snow.

Other common methods of keeping drivers in their intended travel lanes include physically restraining drivers by installing delineating poles, concrete barriers, and guardrails (Johnson 2000) and installing raised pavement reflectors on either side of the lane (Harwood 1993). Not only do these reflectors provide a visual indication of the boundaries of the travel lane, they cause the vehicle’s tires to move up and down slightly when driven over, producing a rumbling noise and causing the vehicle to vibrate. This harmless audible and tactile response is effective at gaining the attention of sleepy or otherwise inattentive drivers who might not otherwise respond to the visual indicators. These warnings are intended to give inattentive or drowsy drivers time to react that they otherwise would not have (Suzman 1999). Raised pavement reflectors are easily removed by the blade on snowplows and thus are not practical in many locations in the United States (Harwood 1993).

Rumble strips were first developed by the Illinois Highway Department in 1954 to warn drivers that they were

approaching stop signs at rural intersections (Gupta 1994). Rumble strips of a raised or grooved pattern of specific dimensions are placed on the roadway surface or shoulder at specific intervals to warn drivers of the need to stop, slow down, or change lanes (Harwood 1995). They are also used to indicate changes in roadway alignment, indicate that the vehicle has partially or completely left the travel lane, and alert the driver of other unexpected situations (Harwood 1993). In the case of raised rumble strips, the tires from the vehicle are raised as they contact the leading edge and pass over each rumble strip. In the case of grooved rumble strips, the tires from the vehicle sink into the grooved depressions and contact the trailing edge of the groove as they pass over the rumble strip. This repeated striking of the tires with these surfaces produces noise providing the driver with the audible warning and vibration in the vehicle providing the tactile warning.

#### Centerline Rumble Strips

A number of cases of the use of CLRS have been reported in the recent literature and are summarized here. It should be noted that unless otherwise specifically discussed, most studies reported in the literature do not provide sufficient detail to judge the statistical validity of the results. Some report only the numbers of crashes before and after installation, which is not statistically significant in and of itself.

During the literature review and survey for this synthesis, it was found that there are no standard definitions of width and length of CLRS. In this report, the lesser dimension along the roadway centerline will be called “width,” and the larger dimension perpendicular to the centerline will be called “length.” For clarification see Figure 1.

In 1995, on a section of highway in California, there were 6 fatal crashes resulting in 14 deaths versus an average of 2.7 fatal crashes per year for the previous 9 years (Fitzpatrick et al. 2000). The California DOT (Caltrans) conducted a demonstration project that included raised profile thermoplastic striping to provide enhanced nighttime visibility (see Figure 2).

The Caltrans demonstration project also included ground-in rumble strips constructed on the highway centerline to replace the double yellow strips that had been in place (Fitzpatrick et al. 2000). A schematic of a typical section is shown in

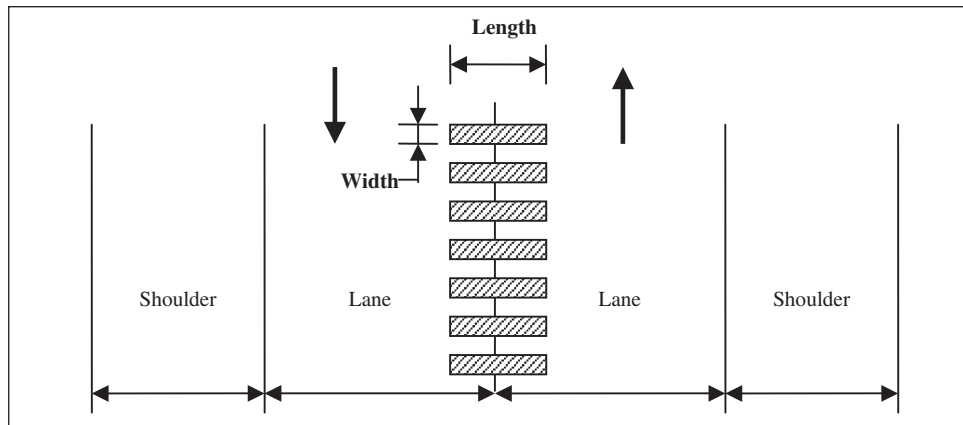

FIGURE 1 Definition of milled CLRS length and width.

Figure 3. Additionally, raised, yellow, retroreflective pavement markers were installed along the rumble strips spaced 28 in. (71.1 cm) apart. This system of raised thermoplastic, milled rumble strips, and raised pavement markers all contributed to audible and vibratory warning for straying vehicles. Shoulder rumble strips were also included in the 23 mi (37.0 km) demonstration section.

Figures 4 and 5 show typical sections of the Caltrans demonstration project and alterations used for two-direction no-passing zones and one-direction no-passing zones, respectively. Figure 6 shows a typical section for a passing lane section.

Crash data for 25 months after the installation of the demonstration project were compared with 34 months of before data. The comparison showed that 4.5 crashes per month in the before period were reduced to 1.9 crashes per month in the after period (Fitzpatrick et al. 2000). In the before period, there were 10 fatal crashes versus one fatal crash in the after period (Fitzpatrick et al. 2000).

Two other highway sections where CLRS were used were described in *NCHRP Report 440* without naming the state or area (Fitzpatrick et al. 2000). The first was described as a principal highway that connects an Interstate to small towns and is

a commuter and recreational route. Both the crash and severity rates were below the average for similar roadways within the metropolitan area but above the statewide average. Figure 7 shows the CLRS plan and spacing details and presents typical sections of this rumble strip application. A 2-year before and 2-year after study of the crashes within the rumble strip areas did not appear to show a significant crash reduction that could be attributed to the rumble strip installation (Fitzpatrick et al. 2000).

The second highway, identified only as connecting a major northwestern city and nearby suburban and small cities, had several opposite-direction crashes that may have been the result of passing maneuvers (Fitzpatrick et al. 2000). The DOT (not identified) installed CLRS, lane striping, and guardrails on a 10-mi (16.1-km) section. The state provided crash data for 1 year before and 1 year after installation, which showed a 23% reduction in total crashes, with most of the crash reduction being the result of a decrease in rear-end crashes (Fitzpatrick et al. 2000). It should be noted that rear-end crashes are probably not related to CLRS.

It should also be noted that in at least two of the projects described, several other treatments were included in the improvements, including centerline and edge line rumble

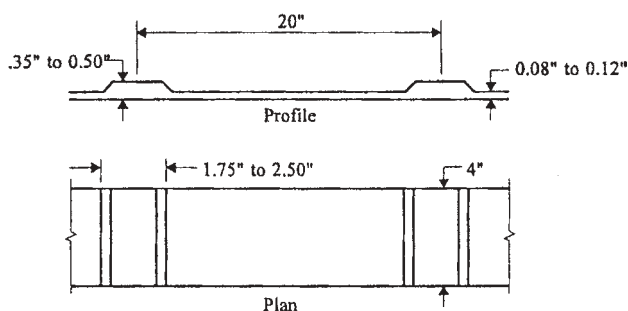

FIGURE 2 Schematic of a raised profile thermoplastic traffic stripe (Fitzpatrick et al. 2000).

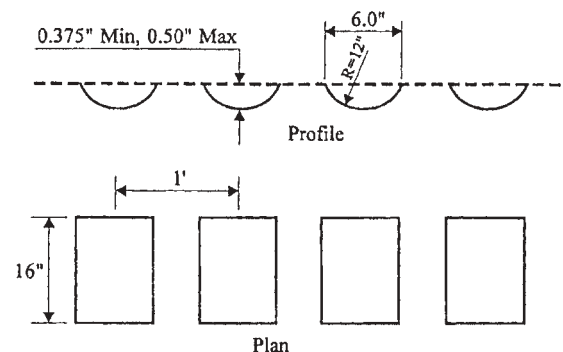

FIGURE 3 Schematic of rumble strip (ground-in) (Fitzpatrick et al. 2000).

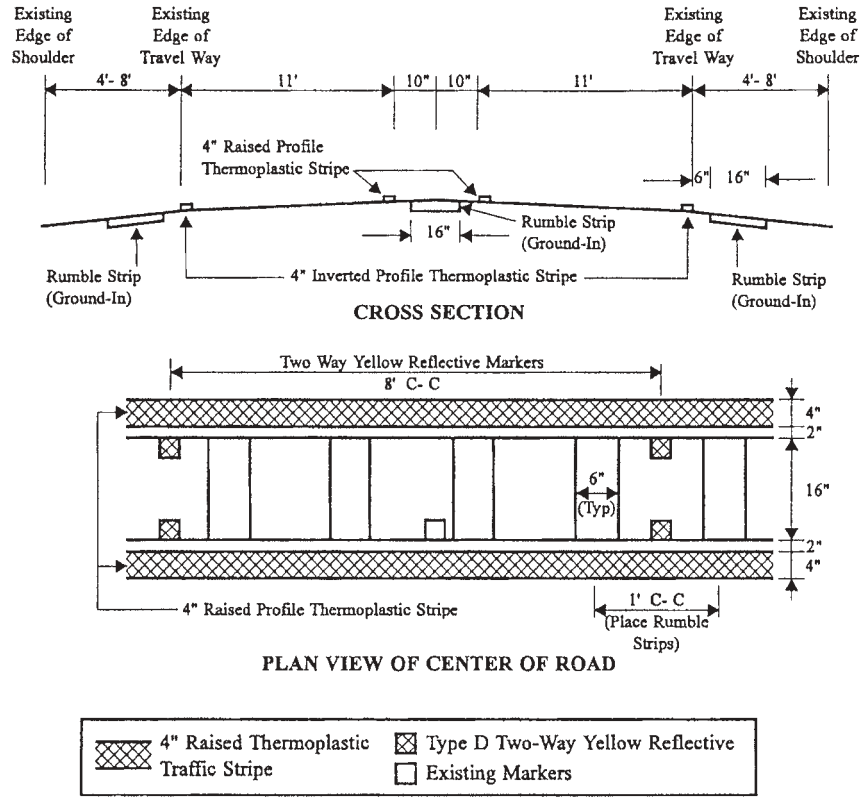

FIGURE 4 Typical section for two-direction, no-passing zones (Fitzpatrick et al. 2000).

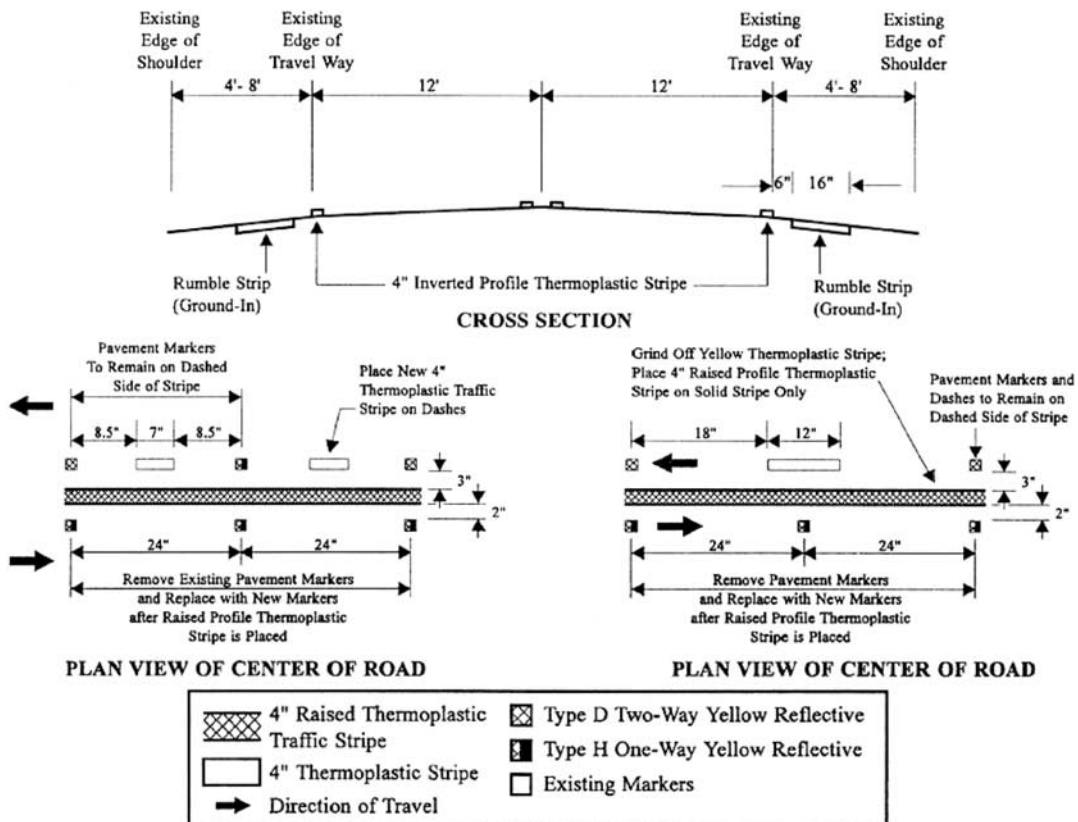

FIGURE 5 Typical section for one-direction, no-passing zones (Fitzpatrick et al. 2000).

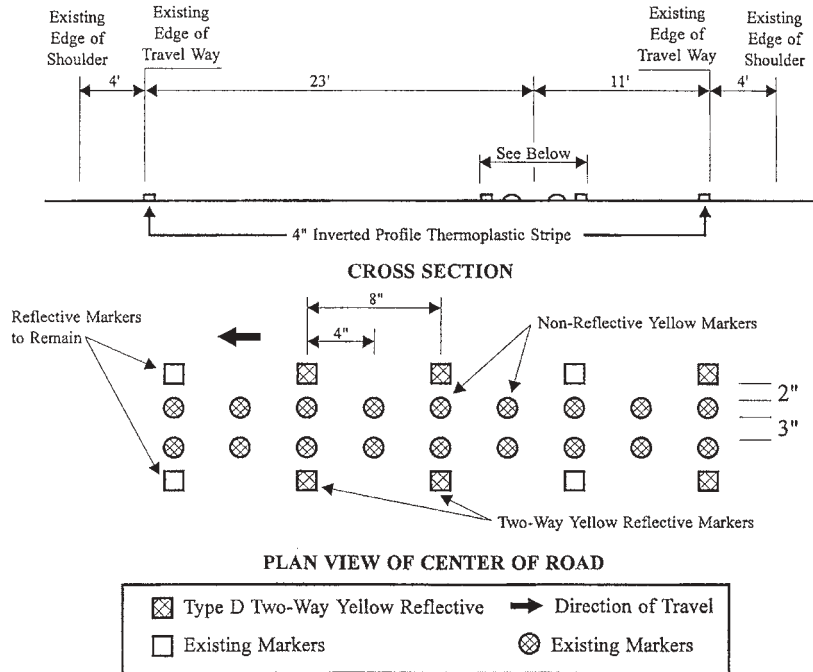

FIGURE 6 Typical section for passing lane section (Fitzpatrick et al. 2000).

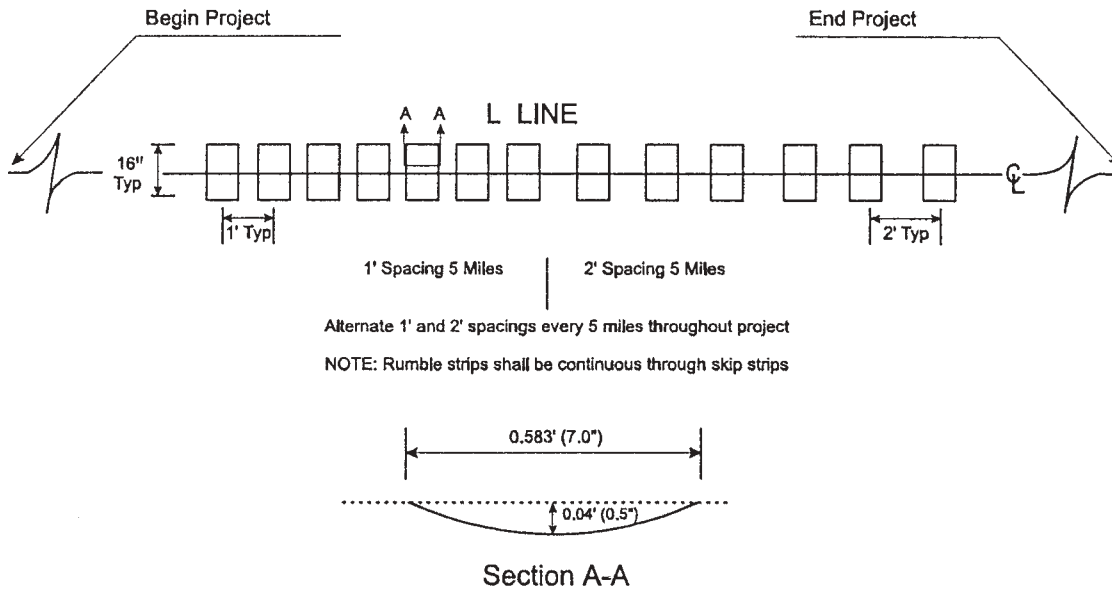

FIGURE 7 CLRS plan and spacing details (Fitzpatrick et al. 2000).

strips (Fitzpatrick et al. 2000). It appears that at least some states that have installed CLRS also include other elements in the project. This makes it difficult in the analysis to separate the effect of CLRS from the effect of the other elements of the project.

The literature search did not identify any issues regarding motorcyclists and CLRS. Only one subjective comment on motorcyclists was found. The previous Chief of the Bureau of Traffic Engineering and monitor of the Kansas CLRS

research at Kansas State University conducted a subjective evaluation by riding his motorcycle over CLRS in Colorado and various test sections on Kansas’s roads, and his opinion is that they present no safety problem (personal communication, M. Crow, Bureau of Traffic Engineering, Kansas DOT, Jan. 22, 2001).

Most reports and studies of bicycle-friendly rumble strips relate to shoulder rumble strips. For example, the Transportation and Equity Act for the 21st century (TEA-21) spec-

ifies that bicyclists and pedestrians should be considered when scoping all projects. This would suggest that bicycle and pedestrian usage, shoulder width and shoulder rumble strip issues need to be considered during the planning and design of any project, including resurfacing projects.

In a recent publication, *NCHRP Report 500: Guidance for Implementation of the AASHTO Strategic Highway Safety Plan, Vol. 4: A Guide for Addressing Head-On Collisions*, CLRS is presented as a strategy to keep vehicles from encroaching into the opposite lane (Neuman et al. 2003). The report notes that there is no standard design and that rumble strips may either be continuous or alternate with gaps.

Because CLRS do not require changes in the overall cross section of the roadway, they would be compatible with other strategies, such as shoulder rumble strips and horizontal curve improvements. This strategy, according to Neuman et al. (2003), although fairly widely used, has not been sufficiently evaluated to be considered proven. The report has one caveat:

These studies appear to involve 'high-crash sites.' Due to the 'regression to the mean bias,' the estimates of effectiveness are

probably inflated to some degree. Thus, there remains a need for well-designed before/after studies that can produce more accurate results of effectiveness (Neuman et al. 2003, p. V-6).

The report concludes that CLRS have not been sufficiently evaluated to be considered a proven strategy. However it points out that the application (CLRS) has been tried and accepted in a number of instances and that there have been no significant findings of negative effects from the use of CLRS.

#### Delaware

The Delaware DOT (DeIDOT) installed CLRS on 2.9 mi of route US-301. This was designed to mitigate head-on crashes and reduce public pressure to upgrade the route to a four-lane highway [see [www.deldot.net/static/projects/rumblestripindex.html](http://www.deldot.net/static/projects/rumblestripindex.html) (last accessed Nov. 2003)].

The rumble strips were milled 16 in. wide and spaced 12 in. apart (see Figure 8). A before-and-after study compared average yearly crashes during a 3-year period before (Aug. 1991 to July 1994) to an 8-year period after (Dec. 1994 to Nov. 2002). The results are presented in Table 1.

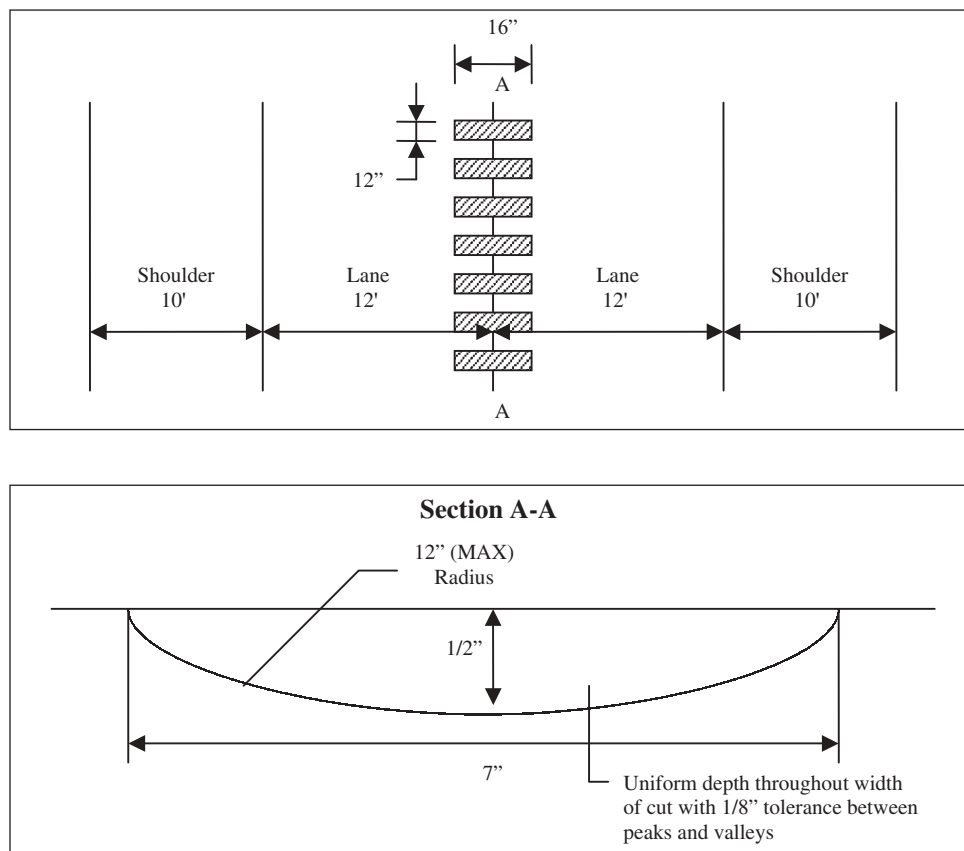

FIGURE 8 Rumble strip detail for Delaware project ("Centerline Rumble Strips, the Delaware Experience" 2003).



TABLE 1  
BEFORE-AND-AFTER ACCIDENT SUMMARY

Accident Type	Average Number of Accidents per Year		
	Before Period	After Period	Percent Change
	8/91–7/94 (3 years)	12/94–11/02 (8 years)	
Head-On	2/year	0.1/year	–95
Drove Left of Center	2/year	0.8/year	–60
Property Damage	6.3/year	7.1/year	+13
Injury	4.7/year	4.9/year	+4
Fatal	2/year	0/year	N/A
Total	13/year	12/year	–8
ADT	16,500 (1994)	22,472 (2002)	+4% yearly

Notes: ADT = average daily traffic; N/A = not available.  
(Source: “Centerline Rumble Strips, the Delaware Experience” 2003.)

The number of property damage and injury crashes increased slightly; however, the average number of head-on collisions decreased by 95%, and there were no fatal crashes during the 8-year after period. Furthermore, crashes owing to crossing the centerline decreased by 60%. These decreases occurred despite a 4% yearly increase in traffic ([www.deldot.net/static/projects/rumblestripindex.html](http://www.deldot.net/static/projects/rumblestripindex.html)).

The cost per linear foot of roadway for CLRS installation varied from \$0.20 to \$0.60, excluding traffic maintenance. This led DelDOT to claim a benefit–cost effectiveness of 110 to 1, as stated in a DelDOT website: “for every dollar DelDOT spent, society has saved \$110 in medical costs, insurance, legal fees, long-term care, property damage, and other expenses related to serious accidents and fatalities” ([www.deldot.net/static/projects/rumblestripindex.html](http://www.deldot.net/static/projects/rumblestripindex.html))

The following advantages and disadvantages were reported by DelDOT:

- Advantages
  - Reduces the number of head-on collisions owing to driver inattention, driver error, and fatigue;
  - CLRS installation costs are low;
  - No noticeable degradation of pavement;
  - Rumble strips require little or no maintenance;

- Milled rumble strips can be installed on new or existing pavements; and
- Unlike other safety features that decrease in effectiveness over time as a result of the “novelty” effect, this is not an issue for drowsy drivers.
- Disadvantages
  - Noise produced by rumble strips may be disruptive to nearby residents; and
  - CLRS potentially transferring a head-on collision to locations without CLRS.

DelDOT’s implementation of CLRS was recognized with a 2001 National Highway Safety Award by the FHWA and the Roadway Safety Foundation.

DelDOT concluded that, “Due to low installation and maintenance costs, CLRS were an effective method of reducing head-on collisions on two-lane, rural highways” (“Centerline Rumble Strips, the Delaware Experience” 2003).

#### IIHS Study

A comprehensive before-and-after study was undertaken by Persaud et al. (2003) to estimate the nature and magnitude of crash reductions associated with the installation of CLRS on rural, undivided, two-lane roads. As shown in Table 2, data were drawn from seven states: California, Colorado, Delaware, Maryland, Minnesota, Oregon, and Washington. In total, 98 treatment sites along approximately 210 mi of road were studied. Statistical procedures were used to account for RTM and to normalize changes in traffic volume and other factors. Overall, motor vehicle crashes at treated sites were reduced by 14% and injury crashes by an estimated 15%. Head-on and opposing-direction sideswipe crashes—the primary target of CLRS—were reduced by an estimated 21% and head-on and opposing-direction sideswipe crashes involving injuries by an estimated 25% (see Table 3).

The authors of the IIHS study concluded that “this result, taken together with the fact that installation costs are rela-

TABLE 2  
SUMMARY OF TREATMENT SITE DATA USED IN THE ANALYSIS

State	Miles	Sites	Before Period				After Period			
			Mile		Crash Count		Mile		Crash Count	
			Years	AADT	Total	Injury	Years	AADT	Total	Injury
California	47.8	29	206.5	2,235	679	257	112.5	10,430	351	144
Colorado	16.9	10	118.4	5,000	551	262	84.6	6,154	415	187
Delaware	2.9	1	8.4	16,500	34	16	21.3	21,685	82	38
Maryland	30.4	11	91.4	11,680	156	55	42.5	12,991	55	14
Minnesota	66.2	24	508.6	9,305	751	158	158.6	10,315	275	41
Oregon	3.1	2	22.8	11,400	31	20	4.6	11,150	6	3
Washington	43.5	21	166.5	7,200	308	116	173.3	7,963	297	109
Total	210.8	98	1,122.6	8,820	2,510	882	597.3	9,858	1,481	536

Note: AADT = average annual daily traffic.  
(Source: Persaud et al. 2003.)

TABLE 3  
COMPOSITE RESULTS

Miles	Sites	Crash Type	Crashes Recorded in After Period		Empirical Bayes Estimate of Crashes Expected After CLRS (standard error)		Reduction (95% confidence interval)	
			All	Injury	All	Injury	All	Injury
210.8	98	All	1,481	532	1,724.0 (39.5)	629.1 (22.7)	14% (8–20%)	15% (5–25%)
		Frontal/opposing direction sideswipe	147	81	186.5 (10.5)	106.7 (7.7)	21% (5–37%)	25% (5–45%)

(Source: Persaud et al. 2003.)

tively low, suggest that consideration should be given to wider application of center line rumble strips on rural two-lane roads to reduce injury crashes” (Persaud et al. 2003).

### Kansas Studies

The Kansas DOT (KDOT) was considering the installation of CLRS in 1999 and sponsored a study that had three parts or phases. Before KDOT installed CLRS, it wanted to undertake a literature review and survey to get information on their effectiveness, possible negative aspects, and optimal dimensions and patterns. A field test of several patterns was also conducted. In the fall of 1999, Kansas State University researchers sent an e-mail survey to DOTs in each of the 50 states; Washington, D.C.; and Canadian provinces. This survey addressed the following questions:

- Are CLRS in use?
- How were they constructed (milled or rolled)?
- What are their dimensions (width, length, depth)?
- What pattern type was chosen?
- Are they located in all zones or only in double yellow “no-passing” zones?
- How long have they been in use?
- Have any data been gathered?
- What type of research was conducted on that data?
- What were the results?

Twenty-four replies were received to this survey—a response rate of 40%. Nine respondents—Arizona, California, Colorado, Connecticut, Massachusetts, Pennsylvania, Oregon, Washington, and the Canadian province of Alberta—indicated they had installed CLRS.

California, Oregon, Massachusetts, Washington, Arizona, Colorado, Connecticut, Pennsylvania, and Alberta, Canada, had CLRS installed at various locations and provided the information sought by the KSU researchers.

A follow-up telephone survey was conducted in the fall of 1999 of the DOTs in Arizona, California, Colorado, Pennsylvania, Oregon, Washington, and Alberta, which had CLRS in place. The main purpose of the survey and

phone contacts was to accumulate and analyze data regarding the types and dimensions of CLRS being installed in these locations and to learn of any problems or concerns that arose. This information as presented by Rys et al. (2003) can be seen in Table 4.

During the 1999 phone survey, several positive comments and no negative comments were received. Examples of the positive comments follow (Russell et al. 2000).

One Colorado district traffic engineer said she was initially “skeptical” of the value of CLRS. The roadway with CLRS in her district is a hilly, winding, two-lane road with a high percentage of slower recreational vehicles. She is now convinced from observation that the continuous (both passing and no-passing zones) CLRS has cut down much “high risk” passing and the “peeking out” maneuver, where drivers move into the left lane to see what is coming (personal communication, P. Hutton, Colorado DOT District Traffic Engineer, 2000).

Probably the strongest advocate interviewed at this time was an Arizona district engineer. He stated that he would put continuous CLRS on all two-lane roads in the district if the money were available. He added that he felt they should be continuous and not just on curves or in no-passing zones. He reasoned that drivers are more likely to go to sleep on long straight stretches (personal communication, D. Dorman, Arizona DOT District Engineer, 2000).

The Caltrans representative provided before-and-after data for their Raised Profile Thermoplastic Stripe/Rumble Strip in San Louis Obispo County study (discussed previously). The 22.8-mi stretch had 126 crashes with 13 fatalities before and 112 crashes with 3 fatalities after installation—a 71% reduction in fatalities (personal communication, B. Nunn, Caltrans, 2000).

Positive results were also reported in Oregon. On a mountain road leading to a ski resort, fatalities dropped from nine (the year before installation) to zero. It was noted that this section of roadway was designated as a safety corridor and had other safety treatments. However, it was stated that Oregon DOT (ODOT) personnel feel very

TABLE 4  
VARIOUS OTHER STATES' MILLED CLRS

State	Width	Length	Depth	Center	All Zones or No Pass Only	Comments
California	6.5 in.	16 in.	0.5 in.	Continuous 24 in.	No pass only	Used with raised thermoplastic striping and reflectors
Washington	6.5 in.	16 in.	0.5 in.	Continuous 12 in.	No pass only	Markings installed over strips
	6.5 in.	16 in.	0.5 in.	Continuous 24 in.	No pass only	Markings installed over strips
Oregon	7 in.	16 in.	0.63 in.	Continuous 12 in.	No pass only	Used with 4 ft median
Arizona	6.5 in.	12 in.	0.5 in.	Continuous 12 in.	All zones	Markings installed over strips
	6.5 in.	8 in.	0.5 in.	Continuous 12 in.	All zones	Narrower to reduce residential noise
	6.5 in.	5 in.	0.5 in.	Continuous 12 in.	All zones	Narrower to reduce residential noise
Massachusetts	6.5 in.	18 in.	0.5 in.	Continuous 12 in.	No pass only	Markings installed over strips
Pennsylvania	6.5 in.	30 in.	0.5 in.	Alternating 24 and 48 in.	No pass only	Across centerlines—12 ft lanes
	6.5 in.	16 in. each	0.5 in.	Alternating 24 and 48 in.	No pass only	Outside centerlines—12 ft lanes
	6.5 in.	16 in.	0.5 in.	Alternating 24 and 48 in.	No pass only	Between centerlines—12 ft lanes
	6.5 in.	18 in.	0.5 in.	Alternating 24 and 48 in.	No pass only	Across centerlines—11 ft lanes
	6.5 in.	10 in. each	0.5 in.	Alternating 24 and 48 in.	No pass only	Outside centerlines—11 ft lanes
	6.5 in.	12 in.	0.5 in.	Alternating 24 and 48 in.	No pass only	Between centerlines—11 ft lanes
Colorado	6.5 in.	12 in.	0.5 in.	Continuous 12 in.	All zones	Markings installed over strips
Connecticut	6.5 in.	16 in.	0.5 in.	Continuous 12 in.	No pass only	Markings installed over strips
Alberta, Canada	6.5 in.	12 in.	0.5 in.	Continuous 12 in.	No pass only	Markings installed over strips

Notes: Width = dimension parallel to travel surface; Length = dimension perpendicular to travel surface; Depth = dimension downward (cut) from the top of the surface; Center = spacing between center of strips.

(Source: Rys et al. 2003.)

positive about CLRS (personal communication, C. Sciscrone, ODOT, 2000).

The Washington interviewee reported having no data, but that the perception was that their system has been very effective. He believes that drivers do not pass as often and are more apt to drive at the speed limit (personal communication, B. Walsh, Washington State DOT, 2000).

In Alberta, Canada, it was reported that they were proceeding cautiously and had no data after 2 years. Although no data were available, the interviewee believed CLRS to be effective and there were no problems or negative concerns (personal communication, B. Kenny, Alberta Canada Highway Department).

The overall conclusion from the telephone survey was that everyone contacted was slightly to very positive about CLRS and that no negative problems were uncovered. The researchers recommended that KDOT proceed with a field demonstration.

After compiling and analyzing the results of the survey, it became apparent that there were no standards for the types and dimensions of rumble strips being used and tested. A proposal was drafted for the evaluation of three different patterns of CLRS (continuous 12 in. on center, continuous 24 in. on center, and alternating 12 and 24 in. on center) consisting of four different widths each (5, 8, 12, and 16 in.), for a total of 12 test patterns. Decibel (dB) and steering wheel vibration (*g*) levels would then be recorded at the driver's position during a series of tests at various speeds using multiple vehicle types. This testing would attempt to validate an optimum pattern for CLRS installations in Kansas.

*Kansas Field Tests* For test purposes, the rumble strips were installed in such a way that the general driving public would not come in contact with them under normal driving circumstances. The Kansas CLRS test patterns were installed in May 2000 on the southbound shoulder of Interstate Highway 135 (I-135), approximately 8 mi south of Salina, Kansas (see Figure 9 for a picture of the milling operation for the Kansas tests).

The 12 test pattern sections were arranged as follows (Brin 2001):

- Section 01: Continuous 12 in. on center/16 in. long.
- Section 02: Continuous 24 in. on center/16 in. long.
- Section 03: Alternating 12 and 24 in. on center/16 in. long.
- Section 04: Continuous 12 in. on center/12 in. long.
- Section 05: Continuous 24 in. on center/12 in. long.



FIGURE 9 Milling machine (Brin 2001).

Section 06: Alternating 12 and 24 in. on center/12 in. long.  
 Section 07: Continuous 12 in. on center/8 in. long.  
 Section 08: Continuous 24 in. on center/8 in. long.  
 Section 09: Alternating 12 and 24 in. on center/8 in. long.  
 Section 10: Continuous 12 in. on center/5 in. long.  
 Section 11: Continuous 24 in. on center/5 in. long.  
 Section 12: Alternating 12 and 24 in. on center/5 in. long.

The cutting spindle on the milling machine used had a 12-in milling radius and the depth of cut was 0.5 in. on all patterns.

The test patterns were constructed on the right shoulder of I-135. KDOT erected a highway work zone that blocked the traffic lane adjacent to the test strips so that highway traffic would not become a factor in the testing and to help ensure the safety of the drivers of the test vehicles, which traveled against the normal flow of traffic so that their left wheels would be in contact with the test patterns.

The tests were conducted using seven vehicles, which represented a wide spectrum of the vehicles currently in operation on Kansas highways: two large trucks (a 1996 International Harvester 4900 DT 466 dump truck and a 1995 Ford L8000 dump truck), a full-size pick-up truck (1991 Chevrolet 2500), a full-size passenger car (1993 Pontiac Bonneville), a compact passenger car (1994 Ford Escort Wagon), a minivan (1995 Ford Aerostar), and a sport utility vehicle (1997 Jeep Cherokee).

Testing at this site consisted of both the interior noise level near the drivers' ear and steering wheel vibration. Interior noise level testing was conducted by measuring the noise levels generated by the rumble strips as the vehicles passed over each test section. The data were recorded using a Quest Technologies Model Q-300 dosimeter, with a remote microphone clipped to the driver's collar just below the right ear. This dosimeter operates at 32 samples per second and displays the high decibel reading taken during any 1-s period. These data were entered into Microsoft Excel for evaluation. Each vehicle negotiated the rumble strips at 60 mph (96.6 km), the current speed limit on many of the rural two-lane highways in Kansas.

The average decibel level for each of the seven test vehicles over each of the 12 test sections at a speed of 60 mph (96.6 km/h) was calculated. Although there were many inconsistencies in the data, as can be seen in Table 5, the continuous 12-in. on-center patterns produced the highest average levels of 80 dB to 94 dB at 60 mph, depending on vehicle type (patterns P1, P4, P7, and P10), followed by the alternating 12- and 24-in. on-center patterns (patterns P3, P6, P9, and P12). As for trends in decibel levels owing to rumble strip length, it appeared that the longer rumble strips generally produced higher average decibel levels, but there was no consistency among the longer lengths. This could be a result of the vehicle tires not remaining in full contact with the shorter rumble strip patterns; that is, the shorter the pattern, the lower the probability of the vehicles' left tires making full contact with the pattern.

TABLE 5  
 DECIBEL LEVEL MEAN AND STANDARD DEVIATION AT DRIVER'S POSITION—60 MPH

Vehicle	Pattern Tested											
	P12	P11	P10	P9	P8	P7	P6	P5	P4	P3	P2	P1
1996 IH 4900 DT 466 Dump Truck (GW = 75,000)	—	—	92.24	92.84	91.47	93.41	93.35	92.23	94.12	92.94	92.16	91.23
	—	—	0.852	0.490	0.482	0.546	0.346	0.494	0.429	0.373	0.685	0.316
1995 Ford L8000 Dump Truck (GW = 48,000)	—	88.21	92.31	90.54	90.03	92.01	91.43	90.48	92.73	91.07	90.73	91.34
	—	0.445	0.950	0.283	0.433	0.456	0.592	0.440	0.465	0.587	0.263	0.915
1991 Chevrolet 2500 Pick-up Truck	—	—	85.29	84.11	81.44	88.77	84.18	82.68	87.47	83.77	82.86	83.50
	—	—	1.117	0.753	0.614	1.242	0.896	0.572	0.796	0.452	0.845	1.194
1993 Pontiac Bonneville Full-Size Passenger Car	82.86	79.01	83.32	83.75	79.46	83.59	84.65	79.61	84.24	83.48	80.01	82.89
	1.053	0.703	0.786	0.459	0.371	0.970	0.374	0.150	0.274	0.179	0.312	0.568
1994 Ford Escort Wagon Compact Passenger Car	—	85.60	88.42	88.62	87.75	89.74	87.44	86.57	89.97	87.76	86.22	87.34
	—	0.390	0.990	0.083	0.465	0.483	0.238	0.083	0.430	0.508	0.351	0.711
1995 Ford Aerostar Minivan	82.56	80.62	87.83	84.09	82.83	89.49	86.12	84.97	87.77	85.59	85.89	88.33
	1.255	1.083	0.437	0.604	0.851	0.692	0.668	0.530	0.600	0.612	0.904	1.146
1997 Jeep Cherokee SUV	—	—	—	82.82	79.87	86.76	84.22	80.48	88.65	83.80	81.24	85.63
	—	—	—	0.563	0.725	0.683	1.014	0.419	0.338	0.544	0.821	0.676
Grand Mean	82.71	83.36	88.24	86.68	84.69	89.11	87.34	85.29	89.28	86.92	85.59	87.18

Notes: For each vehicle the first row of numbers is the mean and the second row is the standard deviation.

P12 = Section 12.....P1 = Section 01. — Indicates that the test results were inconclusive.

(Source: Rys et al. 2003.)

Steering wheel vibration testing was conducted by measuring the vibration levels in the steering wheel of each vehicle, which was generated by the rumble strips as the vehicle's left wheels passed over each test section at 60 mph. The data were recorded using a MicroDAQ Model of SA-600 accelerometer, which was firmly attached to the steering wheel of the vehicle by duct tape. During testing, the drivers were instructed to maintain as little contact with the steering wheel as safely possible, so that the dampening effects caused by touching the steering wheel would be minimized.

Although there was considerable variation in the data, the alternating 12- and 24-in. on-center pattern produced the highest average vibration levels in four of the six vehicles and the second highest average in the other two. Conversely, the continuous 24-in. on-center pattern had none of the highest vibration levels and only produced the second highest in two of the six vehicles. Thus, the highest overall vibration was produced by the alternating 12- and 24-in. on-center pattern, followed by the continuous 12-in. on-center pattern; the lowest was produced by the continuous 24-in. on-center pattern.

Based on these tests, it was decided to field test both pattern 4 (12-in. long, continuous 12-in. on center) and pattern 6 (12-in. long, alternating 12-in. and 24-in. on center). The 12-in. rumble strip length was determined subjectively. Length made little difference in the decibel and vibration values and the 12-in. length fit the centerline striping best; that is, 12 in. between the outside edges of 4-in., double yellow centerlines spaced 4 in. apart.

*Surface Considerations* KDOT indicated that milled rumble strips are equally well suited for installations on both asphalt and concrete roadway surfaces, with two possible exceptions: (1) when milling on asphalt, the thickness of the most recent (topmost) overlay should exceed the depth of the rumble strips so that the integrity of the overlay seal with the next layer of asphalt is not compromised; and (2) when milling on concrete, it is important to avoid milling over the roadway joints (personal communication, M. Crow, 2001).

*Installation Costs* The contractor indicated that the cost of installing milled CLRS currently varies between \$0.26 and \$0.85 per linear meter (personal communication, T. Dankert, Dustrol, Inc., Towanda, Kans., 2001). The reason for this wide variation is that there are several factors that influence the overall installation cost. First, anything affecting the speed at which the rumble strips can be milled is a substantial cost factor. These factors include the dimensions of the pattern (longer strips and deeper cuts require more time to mill), as well as the complexity of the pattern being milled. The type of roadway surface is also a factor, as milling in concrete is generally more time consuming than in asphalt, and therefore is costlier. Another factor is the volume of traffic at the installation site, which affects the amount of

traffic control (devices or otherwise) that are needed and could possibly lead to unexpected delays in the installation. Other factors include the overall size of the installation and the travel costs getting the equipment and work crews to and from the installation sites. Finally, the flexibility in the time frame during which the installation is to occur is a cost factor, as a premium is charged for installations that must occur on a rigid schedule versus at the convenience of the installer.

Based on the results of the tests conducted, two patterns were chosen for further testing in an actual highway setting, pattern 4 (continuous 12-in. on center, 12 in. long) and pattern 6 (alternating 12- and 24-in. on center, 12 in. long). These two patterns and dimensions chosen for further study in the field are shown in Figures 10 and 11. Seven mi of each pattern were installed on Route 50 between Newton and Hutchinson, Kansas. An evaluation of drivers' responses was conducted in the fall of 2003, and the results are described in the unpublished reports and materials section of this chapter.

### *Pennsylvania*

The Pennsylvania DOT (PennDOT) implemented CLRS as one of a number of low-cost treatments aimed at reducing highway fatalities. Although PennDOT felt that the safety effectiveness of CLRS was sufficiently documented, it wanted to study the effect on operational characteristics. A research study was implemented to collect and analyze the operational data along sections of two-lane highways. Specifically, the objective of the research was to determine if CLRS affected the lateral placement and speed of vehicles (Mahoney et al. 2003).

Standard PennDOT details of CLRS are shown in Figures 12 and 13 for 12-ft bituminous road (option 2A) and 11-ft bituminous pavement (option 3B), respectively. The pattern consists of rumble strip pairs spaced 2 ft apart (center to center), with a 4-ft center-to-center distance between pairs. For option 2A, each rumble strip is 30 in. (762 mm) long (transverse) and  $7 \pm \frac{1}{2}$  in. ( $180 \pm 13$  mm) wide (longitudinal), and between  $\frac{1}{2}$  and  $\frac{3}{8}$  in. (13 and 16 mm) deep. For option 3B, each rumble strip is 12 in. (300 mm) long and all other dimensions are the same.

To determine if CLRS caused shifts in the lateral placement of vehicles, data were collected at four sites in two phases, each separated by approximately 4 months. At two of the four locations, CLRS were installed after the first phase. The other two sites were control sites use for comparison (Mahoney et al. 2003).

Table 6 lists the four sites. All sections are tangent sections with minimal grade. The data on lateral placement was collected with tape switches. A series of four tape switches were placed in each lane such that the lateral position of vehicles

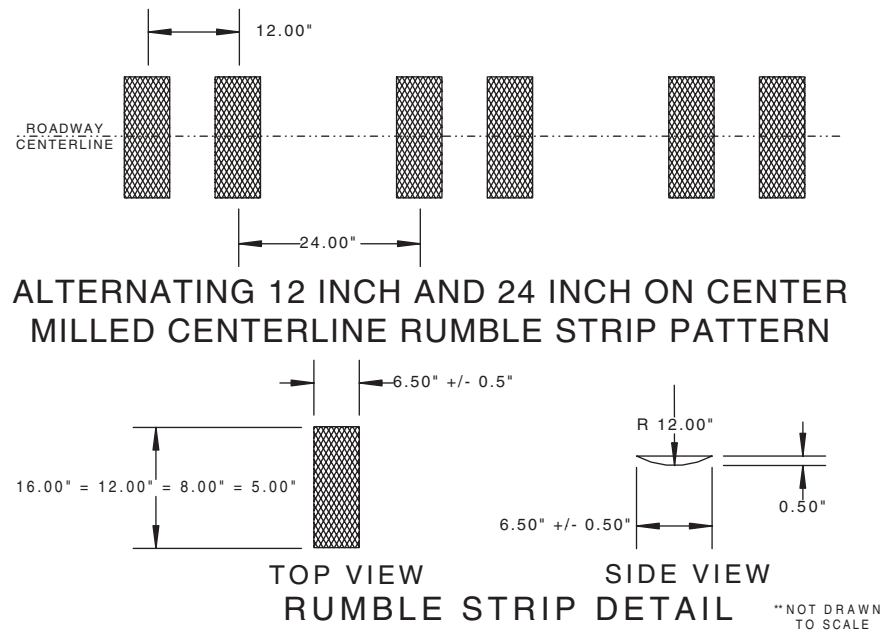

FIGURE 10 Kansas blueprint of alternating 12- and 24-in. on-center pattern (Brin 2001).

could be calculated based on geometric relationships. All data were statistically analyzed.

Table 7 shows that there is a statistically significant difference at  $P < 0.05$  in the mean lateral placement of vehicles on CLRS sections compared with the comparison sections.

For the 12-ft lane sections, there was a shift away from the centerline of 0.46 ft or 5.5 in. For the 11-ft lane sections, there was a shift away from the centerline of 0.25 ft

or 3 in. There was a slight but not statistically significant change in the comparison sites. It was concluded that the changes in vehicle location were the result of the presence of the CLRS.

The variance of vehicle locations was also analyzed. The variance in vehicle placement was significantly less in the CLRS sections. Before-and-after speeds were also analyzed. No significant difference was found in the comparison of speeds in the CLRS section versus the comparison sections.

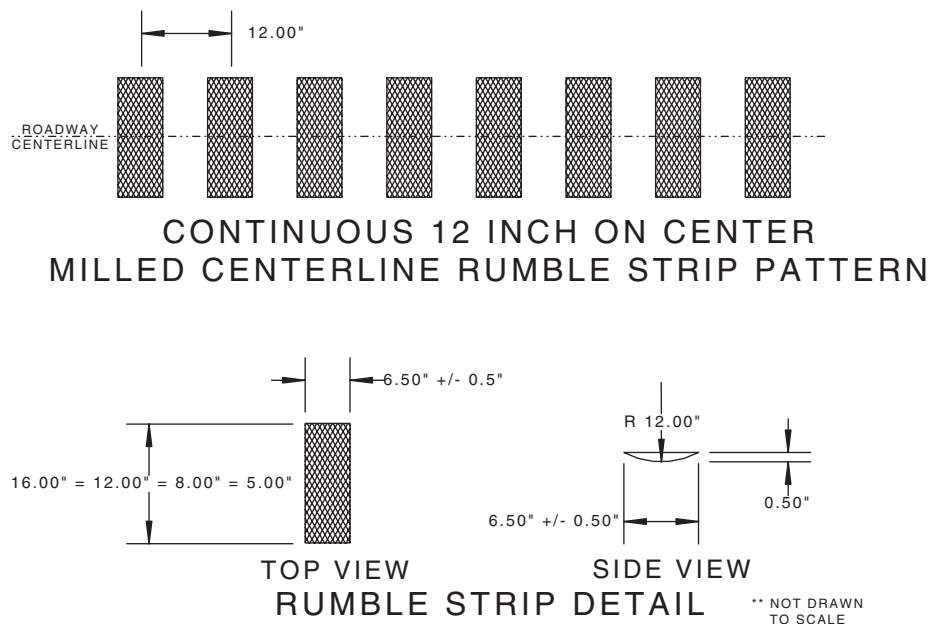

FIGURE 11 Kansas blueprint of continuous 12-in. on-center pattern (Brin 2001).

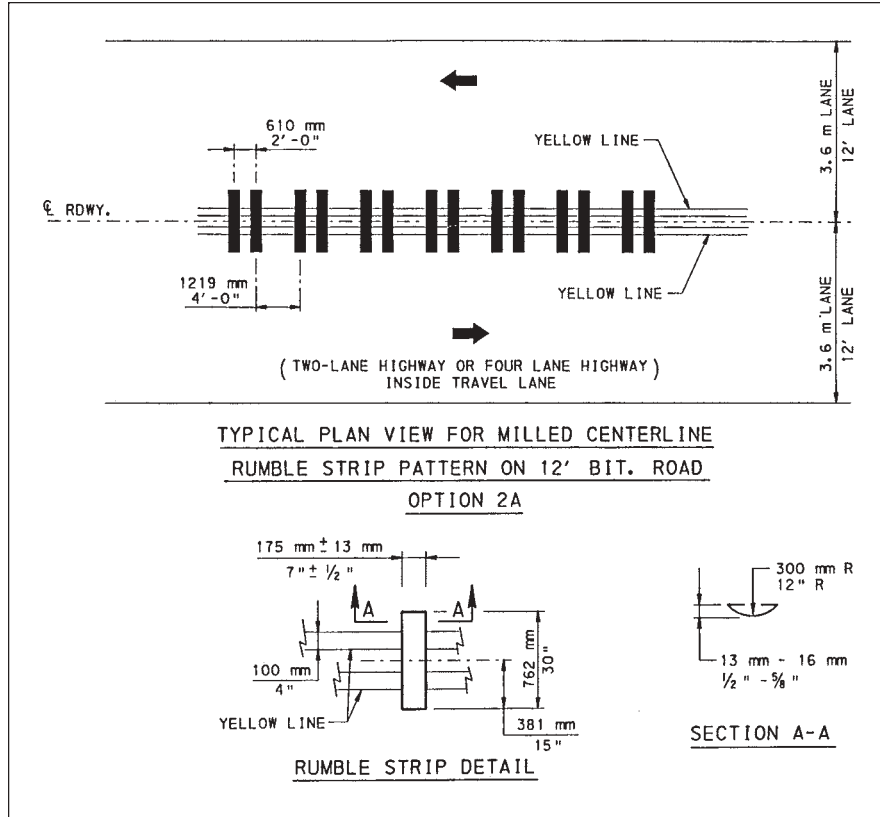

FIGURE 12 Pennsylvania blueprint example 1 (Mahoney et al. 2003).

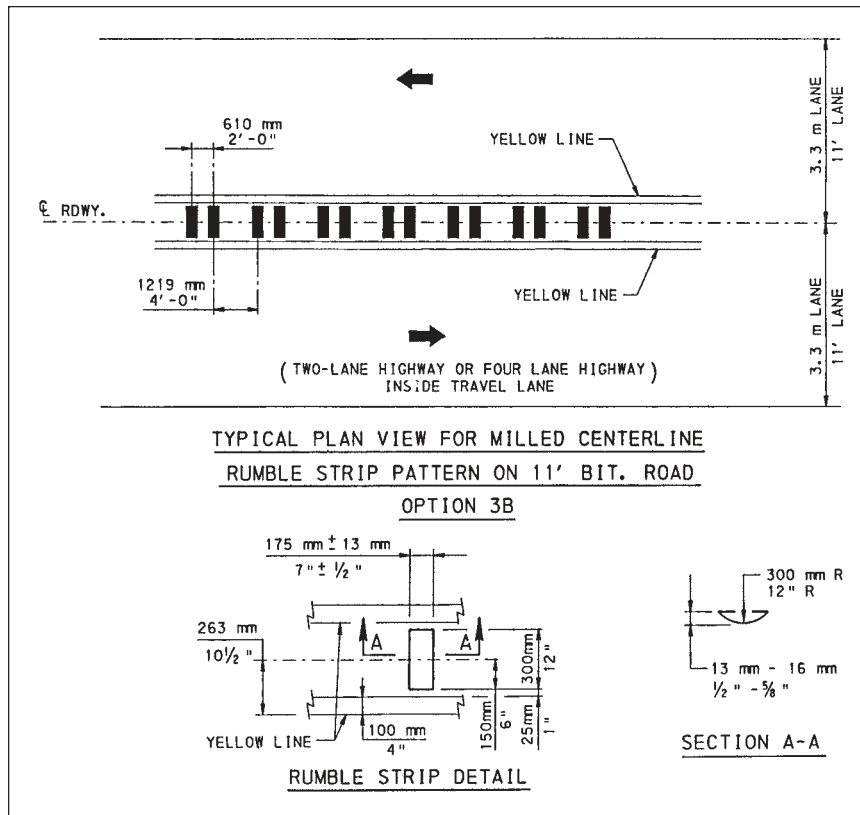

FIGURE 13 Pennsylvania blueprint example 2 (Mahoney et al. 2003).

TABLE 6  
PENNDOT DATA COLLECTION SITES

Site No.	Site Designation	State Route	Location	County	Lane Width	Treatment	Unusual Site Characteristics
1	Treatment CLRS	441	Segment 0040	Dauphin	12 ft	Centerline	Low-volume intersections upstream and downstream of site
2	Comparison CLRS	177	Segment 0060	York	12 ft	—	Low-volume intersections upstream and downstream of site
3	Treatment CLRS	4020	Segment 0100	Lancaster	11 ft	Centerline	Low-volume intersections upstream and downstream of site
4	Comparison CLRS	194	Segment 0180	Adams	12 ft	—	

(Source: Mahoney et al. 2003.)

TABLE 7  
BEFORE-AND-AFTER COMPARISON OF THE MEAN DISTANCE OF VEHICLE CENTROID FROM CENTERLINE (values in feet)

Site	Designation	Before ( $\mu_1$ )	After ( $\mu_2$ )	$\mu_1 - \mu_2$	95% CI		<i>t</i> -stat	<i>P</i> -value
					Lower Bound	Upper Bound		
1	Treatment	6.16	6.62	-0.47	-0.85	-0.08	-2.403	0.017
2	Comparison	6.19	6.22	-0.03	-0.31	0.25	-0.188	0.851
3	Treatment	6.02	6.27	-0.25	-0.45	-0.06	-2.536	0.011
4	Comparison	6.10	6.18	-0.08	-0.32	0.16	-0.638	0.524

Notes:  $\mu_1$  = mean distance after;  $\mu_2$  = mean distance before; CI = confidence interval.

(Source: Mahoney et al. 2003.)

A summary of research findings is shown in Table 8. The report concluded that:

- The presence of rumble strips affects both the mean and variance of lateral vehicle placement for both 12- and 11-ft lanes (Table 7).
- Earlier Pennsylvania studies concluded that a reduction in the variance of lateral placement may lead to lower accident rates.
- No conclusions could be made regarding the effects of the CLRS on mean speed and speed variance (Mahoney et al. 2003).

PennDOT guidelines for installation of milled CLRS can be found in Appendix C.

### Massachusetts

A study of CLRS was funded by the Massachusetts Highway Department. The objective of the research was to evaluate the effectiveness of CLRS in reducing crossover crashes and improving safety on undivided highways. The research was conducted in three phases: Phase I was to survey current use of CLRS; Phase II was to evaluate the effect of CLRS on State Routes 2, 20, and 88; and Phase III was to test drivers' reaction to CLRS in a full-scale driving simulator. Information from the report on this study by Noyce and Elango (2003) is discussed here.

*Phase I: Survey* In phase I of the Massachusetts study, a survey was developed and sent to all states, all Canadian provinces, and selected foreign countries. All 50 states

TABLE 8  
SUMMARY OF RESEARCH FINDINGS (values in feet)  
(MAHONEY ET AL. 2003)

Site/Designation	LW	Before ( $\mu_1$ )	After ( $\mu_2$ )	$\mu_1 - \mu_2$	95% CI LB	95% CI UB	<i>P</i> -value	Before ( $s_1^2$ )	After ( $s_2^2$ )	<i>P</i> -value
1/Treatment	12 ft	6.16	6.62	-0.47	-0.85	-0.08	0.017	2.94	1.73	0.001
3/Treatment	11 ft	6.02	6.27	-0.25	-0.45	-0.06	0.011	1.45	1.36	0.042

Notes: LW = lane width; CI = confidence interval;  $\mu_1$  = mean distance after;  $\mu_2$  = mean distance before; UB = upper limit; LB = lower limit;  $s_1^2$  = variance before;  $s_2^2$  = variance after.

(Source: Mahoney et al. 2003.)



responded. Some of the information received is summarized briefly here (Noyce and Elango 2003).

The following 20 states indicated that they have installed CLRS:

Alaska	Arizona	California	Colorado	Connecticut
Delaware	Hawaii	Kentucky	Maryland	Massachusetts
Minnesota	Nevada	New Hampshire	New Mexico	Ohio
Oregon	Pennsylvania	Virginia	Washington	Wyoming

Of the states that have not yet installed CLRS, 12 replied that they were “considering” CLRS, 4 that they would “probably” install CLRS, and 1 had “definite plans” to install CLRS. Thus, 37 states have installed CLRS or might do so in the future.

In relation to the number of installations, 14 states reported one to two, 3 reported three to four, and 3 had five or more. This would indicate that CLRS were or are experimental and not in widespread use in any state.

In regard to number of lane miles, two states reported less than 1, six reported 1 to 5, three 5 to 10, and nine more than 15 mi of CLRS. Again, this indicates that CLRS were not used extensively in any state at the time of the survey.

In consideration of a question regarding performance satisfaction, 11 states reported satisfactory performance and 4 reported unsatisfactory performance. Three of the four indicated they answered “unsatisfactory” because they had not had time to evaluate, and the fourth gave no reason. New Hampshire was disappointed by the visibility of pavement markings on CLRS under nighttime conditions when snow, salt, sand, etc., collected in the rumble strips or deteriorated the pavement markings.

In answer to a question regarding any unexpected problems, 7 of the 17 respondents who answered this question answered “yes.” The majority (four) noted noise complaints, and the others mentioned bicycle and motorcycle concerns, criticism from emergency vehicle operators, and one was disappointed that the rumble strips did not enhance the retro-reflectivity of the centerline markings.

In regard to a question concerning formal evaluation, two responded that they had conducted one and three reported ongoing evaluations. None were negative. In regard to a question pertaining to having specifications, warrants, policies, or guidelines, 2 of 18 respondents who answered this question responded “yes” (Oregon and Pennsylvania), and the other 16 responded “no,” they had none.

In regard to cost, there was a wide variation in the few responses. Five respondents reported per linear foot costs of \$0.20 (20 cents) to \$3. Nine others reported costs per mile from \$1,000 to \$16,000, with Hawaii being the highest. The most consistent reply (from five respondents) was approxi-

mately \$1,000 per mile. Other examples included Washington at \$11,000 per mile, Minnesota \$5,000 per mile, and Maryland \$750 to \$2,150 per mile.

The last question asked for any positive or negative experiences or general comments that any respondents would like to report. Of 31 respondents, 11 provided comments. Six of the 11 provided information or concerns as follows:

- Colorado received positive comments from the public.
- Indiana, which has no CLRS, was concerned about water pooling and freezing in the winter and noted that it permitted 12-ft-wide vehicles to travel on state highways and that on some roads these trucks would have to travel on the CLRS.
- Montana commented that some of its traffic engineers were “on the fence” about CLRS.
- New Hampshire noted that initial installations encouraged others to request similar treatments but possibly for the wrong reasons; that is, CLRS seem to be requested to keep aggressive drivers from passing inappropriately.
- Pennsylvania reported that feedback from the public indicated that it liked CLRS in the winter when roads are snow covered to alert drivers as to where the center of the road is located.
- Minnesota had the most detailed response and posed several issues they thought should be considered for future research:
  - Do the rumble strips send a clear, easily understood message to the errant driver resulting in a definite and predictable driver reaction? Can the rumbles result in an incorrect driver reaction or an over-reaction?
  - Should rumble strips be installed only in no-passing zones, or instead, along the entire stretch of involved roadway including passing zones? Does the use of rumble strips in both passing and no-passing zones send a conflicting message?
  - What precedent is set by installing rumble strips? What criteria should be used to determine where [CLRS] should be installed? Will the public demand that rumbles be constructed on other roadways, whether warranted or not?
  - Are the centerline rumbles truly effective?
  - Does the existence of the rumble strips on the centerline affect the nighttime effectiveness of the centerline striping? Are more painting materials required with a resultant higher cost?
  - Is the pooling of water or compaction of snow in the rumbles an issue?
  - What additional long-term maintenance needs [are] created for the pavement due to grinding of the rumbles? Are additional costs involved? Is the pavement life affected?
  - What maintenance issues for the rumble strips themselves are raised? Do the rumbles need to be re-ground into the pavement every few years? Do certain maintenance practices tend to prolong or decrease rumble strip life (Noyce and Elango 2003)?

*Phase II: Field Analysis—Site Descriptions* Table 9 describes the locations of the three CLRS sections. No information on the CLRS dimensions or patterns was given in the report. However, in summarizing results of a 1999 survey, Massachusetts reported CLRS dimensions of 6.5-in. width, 18-in. length and 0.5-in. depth, 12-in. spacing between strips, and location in no-passing zones (Noyce and Elango 2003).

In Phase II of the Massachusetts study, crash analysis of several field sites was conducted. Crash data for the CLRS sites from the Massachusetts Highway Department’s Accident Record System was obtained for State Routes 2, 20, and 88 for a minimum of 2 years of before and 2 years after installation.

TABLE 9  
CLRS LOCATIONS IN MASSACHUSETTS

State Route	Town(s)	Limits	Length (miles)	Date of Installation	ADT
2	Erving Wendell Orange Athol	Near Exit 14 in Erving to Mile Marker 78 in Phillipston	9.12	November 1998	9,000
20	Phillipston Sturbridge Charlton Oxford	Route 49 in Sturbridge to Route 12 in Oxford	10*	November 1996	8,600
88	Westport	Drift Road to Briggs Road	6.14	November 1998	7,000

\*A 12,500-ft section of State Route 20 from Depot Road to Richardson's Corner was under construction in 1999 (no rumble strips).

Note: ADT = average daily traffic.

(Source: Noyce and Elango 2003.)

Crashes were screened so that only “target crashes” were considered; that is, head-on collisions, angle collisions, and ROR crashes that traversed the centerline. Comparison (control) sites were identified. Two sites were identified as comparison sites for State Route 2, three for State Route 20, and two for State Route 88.

A statistical analysis of the before-and-after crash data used a comparison group methodology. Statistical procedures were used to predict the expected number of crashes in the after period compared with the observed number after implementation of CLRS. Therefore, the primary measure of effectiveness was whether fewer crashes than predicted occurred after installation of CLRS. Predicted crashes were a function of the previous year's crash frequencies and trends at the comparison sites. The report concluded that

The results of the crash data analysis in Phase II showed no significant change in crash frequencies before and after the installation of centerline rumble strips. There were no significant trends in the comparison sites to conclude that the stability of the crash frequencies at the study location was a function of the environment. There is no evidence to suggest that the installation of the centerline rumble strips significantly (statistically) reduced crash rates. Some positive reductions in injury crashes were observed on State Routes 2 and 88, although the results were not significant. No fatal crashes have occurred on State Routes 2 and 88 since the installation of centerline rumble strips, which may be attributed to the benefits of centerline rumble strips. Three cross-over-the-centerline crashes did occur on State Route 20 after the centerline rumble strips were installed, all near the same geometric feature. Roadway improvements in this area are currently being made (Noyce and Elango 2003, p. 62).

*Phase III: Driving Simulator* Phase III of this study was conducted with the University of Massachusetts full-scale driving simulator to evaluate driver reaction and behavior when encountering CLRS. Three issues were addressed. First, do CLRS distract drivers during the passing maneuver? Second, are drivers conditioned to steer left when coming across shoulder rumble strips and will they turn left when encountering CLRS? Third, could drivers be so startled when encountering

CLRS that they make a strong corrective swerve and lose control (Noyce and Elango 2003)?

Details of the simulator can be found in the report. Subjects were informed that the experiment was to test their ability to find a letter in roadside signs—a task requiring them to concentrate and take their eyes off the road. At the point of the signs—the experimenter shifted the road scene (lane shift) so the subjects were suddenly on shoulder or CLRS. The simulator was set up in an attempt to rumble properly, primarily with devices attached to the seat frame on the left or right (and two others) and a rumble noise under the hood.

Several roadway scenarios were created with two visual databases. As stated in the report, “The first three scenarios in each module had lane shifts to the left, forcing drivers to unexpectedly encounter right shoulder rumble strips. This gave drivers an ad hoc experience with right shoulder rumble strips” (Noyce and Elango 2003, p. 25).

Key results from Phase III were as follows:

- Drivers took more time to return to the travel lane when encountering CLRS, but this changed with experience.
- Drivers tended to correct vehicle trajectory more quickly with shoulder rumble strips.
- Approximately 27% of drivers made an initial leftward correction (Noyce and Elango 2003).

The report included the caveat that the increase in the percentage of drivers correcting left could be the result of laboratory conditions and the “uniqueness of the simulated driving environment.”

Although a statistically significant decrease in all crashes was not found, the Massachusetts study concluded that considering crash trends and results of all three phases, CLRS are an effective traffic control device and safety countermeasure in areas with history of cross-over, fatal, and injury crashes (Noyce and Elango 2003).

There following recommendations were made in the Massachusetts report:

- CLRS could be used as a countermeasure in areas where cross-over crashes occur.
- Follow-up analysis should be completed.
- Further study of the human factors elements should be conducted (Noyce and Elango 2003).

### Colorado

In 1996, Colorado installed 17 mi (27.36 km) of CLRS on a winding, two-lane mountain highway for evaluation.

A Colorado DOT report that compared traffic and crash records for 44-month before and 44-month after periods showed the following (Outcalt 2001):

- Head-on accidents decreased from 18 to 14;
- Sideswipe from opposite directions decreased from 24 to 18;
- Average daily traffic (ADT) increased from 4,007 in 1992 to 5,661 in 1999; and
- Average ADT for the 44-month period before construction was 4,628, and 5,463 for the 44-month period after construction.

The Colorado report concluded that there was a statistically significant decline in the number of cross-over crashes on the sections where CLRS were installed. Head-on crashes declined 34% per million vehicles and sideswipe crashes declined 36.5% during a period when ADT increased 18% (Outcalt 2001).

The report acknowledged that there could be increased danger to motorcyclists and bicyclists, increased noise, and increased wear on the pavement marking stripes. Nevertheless, the report recommended that because the results “clearly demonstrated the effectiveness of reducing opposite direction crashes on two-lane highways,” the use of CLRS in areas with a history of this type of crash was highly recommended (Outcalt 2001). The recommendation was made with the caveat that because of potential danger to motorcyclists and bicyclists, CLRS should not be used indiscriminately, but limited to areas that have experienced high numbers of head-on and/or cross-over type crashes.

The Colorado report was not without controversy. A graduate student at the University of Colorado at Denver statistically analyzed the crash data from the Colorado test section. The mean crashes per month for the two 44-month periods were tested for statistical difference using a *t*-test. His conclusion was that there was no statistically significant reduction in cross-over crashes at the 90% confidence level (Davis 2003).

A bicycle organization in Colorado opposed the use of CLRS, particularly on two-way, two-lane mountain road-

ways without shoulders. Colorado has a significant number winding roads with no shoulders owing to topography, a substantial number of bikes in the summer, and a fair number of ROR crashes (personal communication, P. Demos-thenes, Safety Engineer, Colorado DOT, 2003).

An organization, Bicycle Colorado, promoted a campaign against CLRS. In a newsletter, its opposition to further installation of CLRS was summarized as follows: “[W]e must ride at the roads’ edge and motorists must cross the centerline to ensure a distance when passing. Jefferson County (Colorado) plans to mill rumble strips into the centerline creating a hazardous situation for bicyclists and leading to increased conflicts” (“Help Stop Rumble Strips . . .” 2002).

Bicycle Colorado expressed concerns that motor vehicles would shy away from the centerline and crowd and endanger bicyclists traveling along the edge of the road. Bicycle Colorado requested more research and the cessation of the installation of CLRS until (1) paved shoulders for cyclists can also be provided, (2) a public meeting is held to allow comment by all users of these roads, and (3) a study is completed detailing the impact of CLRS on cyclists (news from Bicycle Colorado, Dec. 6, 2002, on <http://bicyclecolo.org/site/page.cfm?pageID=281>).

### Transportation Association of Canada

In 2000, the Transportation Association of Canada (TAC) published a synthesis of best practices for the implementation of rumble strips (*Synthesis of Best Practices . . .* 2000). It provided Canadian highway agencies with a summary of current practices to assist in the development of local guidelines and policies. As of 2000, Alberta was the only province that had implemented CLRS.

The TAC synthesis summarized key findings as follows:

- The milled-in method of CLRS application has been successfully applied on new and existing pavement.
- Raised CLRS are not appropriate for application in Canada owing to winter weather conditions.
- CLRS are mostly applied in no-passing zones on undivided highways.
- The effects of implementing CLRS in passing zones should be reviewed once additional studies on this topic have been completed.
- Continuous CLRS are applied on undivided highways as mitigation measures if the local agency identifies a history of head-on or sideswipe collisions and a cost-benefit analysis shows that the implementation of CLRS is cost-effective.
- The highway agency may undertake a cost-benefit analysis to confirm the cost-effectiveness of implementing CLRS for low average ADT volume roads (*Synthesis of Best Practices . . .* 2000).

Based on a review of North American practices, the TAC Synthesis presented the following dimensions for continuous, milled-in CLRS. (Note: The TAC length and width dimensions are reversed from those defined for this synthesis): strip shape, rounded; strip width, 300 mm within painted lines; spacing between strips, 300 mm; strip depth,  $8 \pm 2$  mm; and strip length,  $175 \pm 25$  mm.

CLRS should be placed in the center of the road within the centerline pavement markings. See Figure 14 for an illustration of the Canadian CLRS. Table 10 presents design dimensions and comments for milled-in CLRS.

Various depths of milled-in rumble strips were tested using several different vehicle types (tractor-trailer, pick-up truck, and motorcycle). The tests led to the following conclusions (*Synthesis of Best Practices . . . 2000*):

1. In-vehicle noise—A depth of 8 mm is required to create any noticeable effect on the tractor-trailers. Depths of 6 mm or less produce no changes in sound level and vibration.
2. Environment noise—Studies show that rumble strips terminated approximately 200 m before residential or urban areas produce tolerable noise impacts on residences. At an offset of 500 m, the noise from rumble strips is negligible.

## UNPUBLISHED REPORTS AND MATERIALS

### Kansas Drivers' Responses to CLRS

The milled CLRS of two types—continuous 12-in. on center and alternating 12-in. and 24-in. (Figures 10 and 11)—were installed in June 2003 on a 15-mi stretch of US-50, between the towns of Newton and Hutchinson. The Kansas State University research team visited the site on November 25, 2003, to distribute survey questionnaires to the road users to learn their responses to the installation of the CLRS. The two CLRS types were marked with signs describing them as Test Section 1 (continuous 12-in. on center) and Test Section 2 (alternating 12-in. and 24-in. on center). One thousand questionnaire postcards were distributed to drivers of this roadway. Vehicle types consisted of approximately equal numbers of passenger cars and large trucks. The response rate to the survey questionnaire was almost 25% (247 respondents of the 1,000 questionnaires distributed).

#### *Survey Questions and Responses*

Eight questions were included in the survey, with most being subjective questions based on the driver's own impressions of the CLRS while traveling on the test sections of US-50. These eight questions and the survey responses are given here.

#### 1. How often do you travel this section of highway?

Twenty-nine percent of the respondents traveled the test section monthly, 21% daily, 18% seldom, 17% two to three times per week, and 16% weekly.

#### 2. Type of vehicle?

The largest percentage of respondents, 41%, drove passenger cars—followed by 23% pick-ups, 19% trucks, 12% vans, and 8% sport utility vehicles. Some of the respondents traveled the test section in more than one type of vehicle.

#### 3. Did your tires make contact with the CLRS?

Thirty-nine percent of respondents had made contact with both the continuous and alternating patterns, 38% had made contact only with the continuous patterns, and 19% did not make any contact with the CLRS.

#### 4. Which patterns do you feel were adequately loud to gain your attention?

Thirty-six percent of respondents felt that both patterns were loud enough to gain their attention, but almost an equivalent percent of respondents, 34%, felt that the continuous pattern was loud enough to gain their attention, and 9% felt that the alternating pattern was best for alerting them.

#### 5. Which patterns do you feel adequately vibrated the steering wheel?

The continuous pattern was felt to vibrate the steering wheel better by 36% of the respondents, 34% felt that both patterns provided adequate vibration to the steering wheel, and 10% felt that the alternating pattern provided adequate steering wheel vibration.

#### 6. Overall, which patterns of rumble strips would you recommend be installed?

A plurality of respondents (38%) recommended the installation of the continuous pattern, 18% the alternating pattern, and 20% indicated either one would be good.

#### 7. Have you ever fallen asleep or dozed off while driving a vehicle?

Fifty-two percent of the respondents replied in the negative, 31% that they had fallen asleep or dozed off once or twice, and 15% that they dozed off infrequently. Many respondents who reported that they had fallen asleep or dozed off while driving believed that shoulder rumble strips had awakened them.

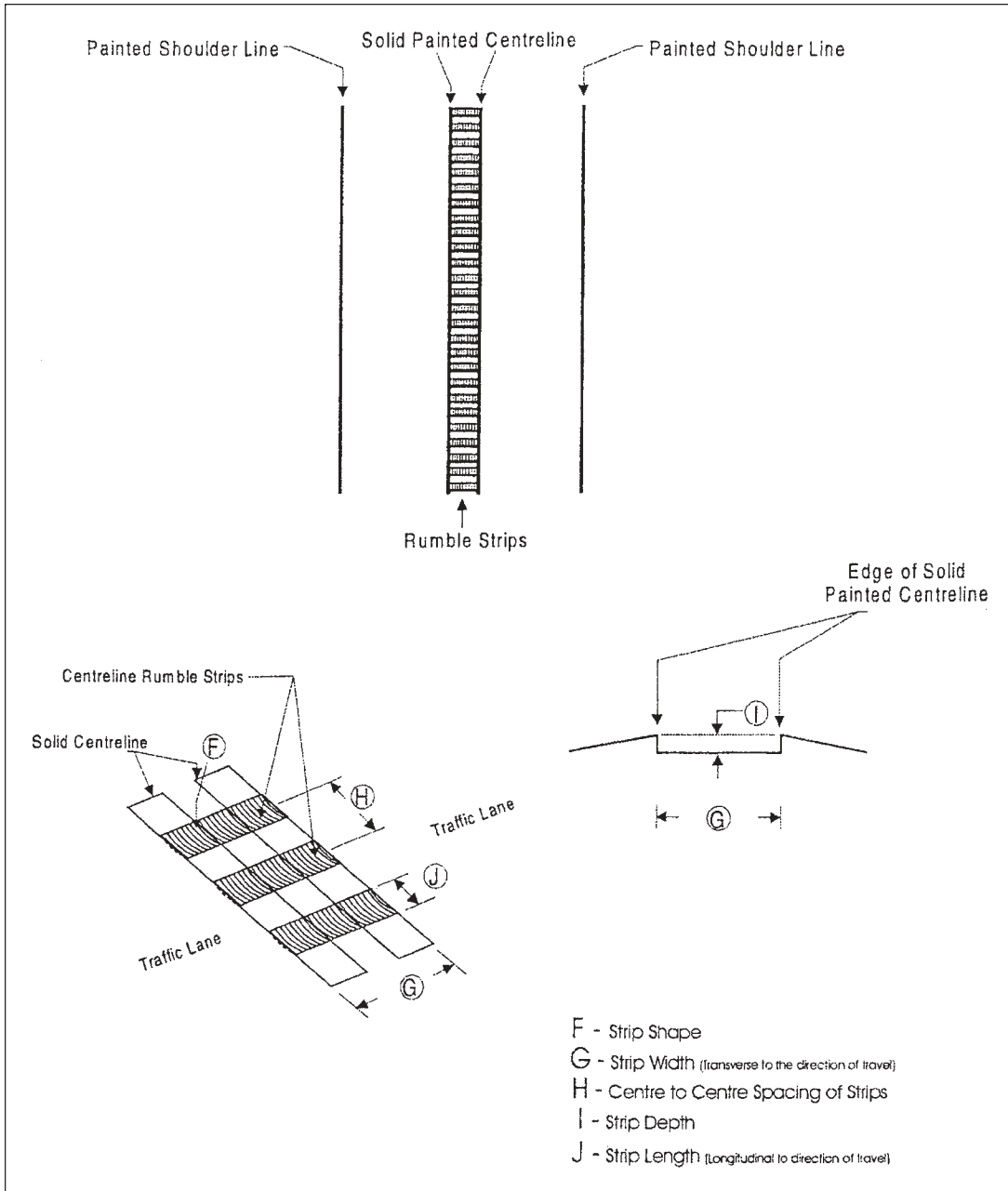

FIGURE 14 Continuous CLRS (*Synthesis of Best Practices . . . 2000*). (Note: Strip width and length are reversed from the definitions established for this synthesis.)

8. Do you think CLRS will reduce accidents?

Ninety-six percent of the respondents felt that the installation of CLRS would reduce accidents.

*Respondent Comments*

Most of the respondents commented that the CLRS were a “good,” “terrific,” or “excellent” idea; could save lives; and should be installed nationwide on all roads. Some felt that they would be helpful in low-visibility scenarios—night, fog,

rain, or snow. There were respondents who felt that continuous rumble strips are better for the centerline with the alternate pattern on the shoulder; this would help them think subconsciously about which way to steer while encountering rumble strips. There was one respondent who felt the CLRS needed to be coated with much more paint.

The comments of concern included the following: CLRS tend to pull the vehicle to the left; the vehicle sways when crossing the rumble strips at 65 to 70 mph; they may be dangerous to cyclists; and because people are already familiar with shoulder rumble strips, there may be a sudden steering

TABLE 10  
DESIGN DIMENSIONS: MILLED-IN CLRS

Dimension	Guideline	Comments
F (strip shape)	Rounded	This is consistent with current practices in North America and with most milling equipment.
G (strip width)	300 mm	The semi-circular shape is preferred because these are easier to clean, if necessary, and they resist the loss of aggregates owing to the small number of sharp edges. For use on typical highways in no-passing zones. Rumble strips span the width of the two solid pavement markings plus the space in between the pavement markings. The rumble strip remains entirely within the painted lines.
H (center to center spacing of strips)	300 mm	This is consistent with most current practices in North America.
I (strip depth)	$8 \pm 2$ mm	A depth of 8 mm provides sufficient noise and vibration to alert drivers without creating excessive noise in the surrounding area.
J (strip length)	$175 \pm 25$ mm	This is consistent with most current practices in North America.

(Source: *Synthesis of Best Practices* . . . 2000).

reaction left when hitting CLRS. One person felt that steering and recovery were difficult with the continuous centerline pattern.

#### *Kansas Field Study Conclusion*

An overwhelming majority of the respondents felt that CLRS were good for preventing head-on collisions and providing greater safety on Kansas roads. The continuous pattern of CLRS was felt to be the best pattern to gain the drivers' attention, being adequately loud and providing adequate vibration, albeit the perception favoring it was similar to those finding both patterns adequate. A slightly smaller percentage of respondents specified that only the alternating pattern was adequate.

#### **New York**

New York plans to install test installations of CLRS within each region in the state to determine their effectiveness and any problems with their construction. The CLRS will be placed only where there are double yellow lines; that is, in no-passing zones. New York is in the process of developing unique specifications for the installation. One problem mentioned is that the milling operation is expected to produce ground asphalt with lead chromate from the yellow striping paint and it will have to be collected and disposed of in an approved landfill (personal communication, J. Bray, NYDOT Safety Engineer, Jan. 2003).

#### **Kentucky**

The Kentucky Transportation Cabinet installed CLRS on the Daniel Boone Parkway, the two-lane section of the Mountain Parkway, and a two-lane section of the Gene

Snyder Freeway. They also have been approved for use on a 7.3-mi section of the four-lane, undivided US-31 in Jefferson, Hardin, and Meade counties; and CLRS are under consideration elsewhere (personal communication, J.M. Yowell, State Highway Engineer, May 27, 2003). This communication points out that although CLRS appear to be promising, they are experimental and all requests for installation have to be reviewed by the Division of Traffic and its recommendation forwarded to the Executive Director of Construction/Operations for approval. Figure 15 shows current details of the Kentucky CLRS. To date, no policy is in place.

#### **Oregon Studies**

ODOT installed and evaluated the safety effectiveness of CLRS. The following information is from a conference presentation (Monsere 2002).

ODOT was faced with a high frequency of cross-over fatal crashes on two high-volume, rural highways. On one 20-mi section, there were 43 fatal and 49 severe injury crashes during a 7-year period. These two highways were US-26, Mt. Hood Highway, and OR-18, Salmon River Highway.

Mt. Hood Highway is a rural, four-lane highway with a posted speed of 55 mph and an ADT of 12,000 to 14,000. Milled-in CLRS were installed on an 8.7-mi section with a 4-ft painted median in no-passing zones only (see Figure 16).

Salmon River Highway is a rural highway of three-lane and two-lane sections, with a posted speed of 55 mph and an ADT of 18,000. Milled-in CLRS were installed on an 8.4-mi section with a 4-ft painted median. No-passing zones were concurrently added in some locations and the application of CLRS was not continuous.

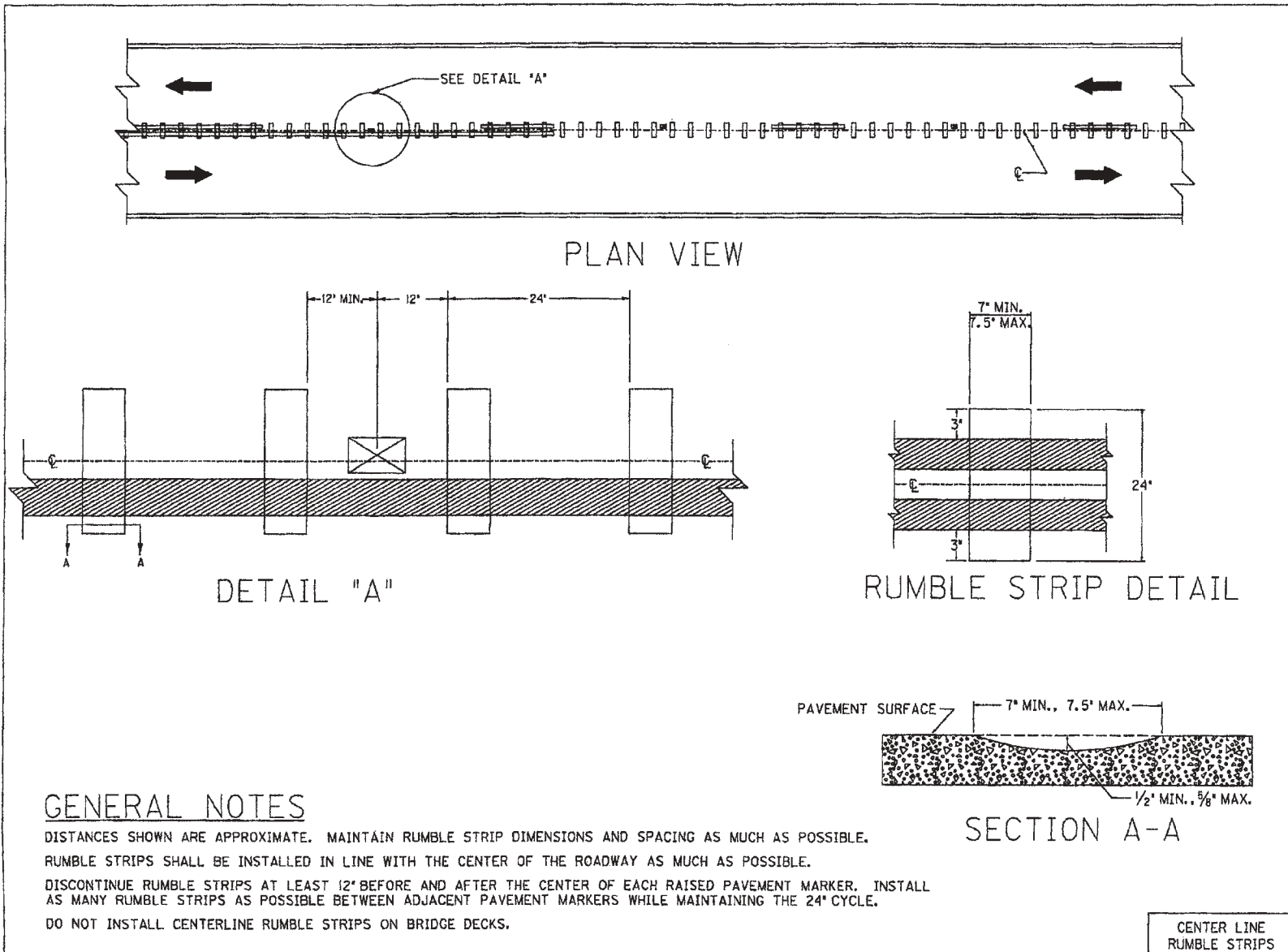

FIGURE 15 Kentucky rumble strip detail (Kentucky Transportation Department).



FIGURE 16 ODOT CLRS installed on Mt. Hood Highway  
(Source: Christopher.M.MONSERE@odot.state.or.us).

Four approaches are planned to evaluate the effectiveness: (1) simple approach, (2) yoked comparison, (3) comparison groups, and (4) Empirical Bayes approach. Only the first two have been used. In addition, analysis using the last two approaches will be undertaken when more years of data are available.

The simple approach showed percent crash reductions from 13% to 100% in five of six sections, and an overall reduction of 69.5% (see Table 11). A drawback for the simple approach is that crash reductions tend to be overestimated.

The yoked comparison approach involves a one-to-one matching of treatment sites to comparison sites. The basic assumption is that matching will account for time trends and, if the treatment were left unimproved, crashes would be in proportion to the comparison site.

The yoked comparison approach combined the various segments of both highways and showed a 79.56% reduction

TABLE 11  
SIMPLE APPROACH

Site	Before		After		Statistical Analysis		
	Years	Target Crashes	Years	Target Crashes	Adjusted Crashes	% Reduction	Z
1	6.1	33	2.7	4	9.2	-72.0	-3.42
2	6.1	2	2.7	1	2.3	15.4	0.15
3	7.4	5	1.4	0	0	-100	—
4	7.4	6	1.4	1	5.2	-13.0	-0.23
5	7.4	8	1.4	0	0	-100	—
6	7.4	1	1.4	0	0	-100	—
Total		55		6	16.8	-69.5	-4.26

(Source: Monsere 2002).

in fatal crashes (with a 95% probability that the reduction was between 50.6% and 91.54%).

An August 27, 2003, news release stated, “The Oregon Department of Transportation is installing CLRS in central Oregon. Rumble strips are a cost-effective way to reduce run off the road accidents and help reduce crossover vehicle crashes by 50%” (“ODOT Installs Safety Rumble Strips . . .” 2003).

A portion of Oregon Highway 126 has a test section with CLRS installed on the yellow center strips, the pattern details of which are shown in Figure 17. All other CLRS in Oregon have been installed in medians, as shown in Figure 18 (Monsere 2002).

ODOT is also testing a pattern that will provide an audible and detectable warning to motorists but is not too jarring to vehicles that pass legally (“ODOT Installs Safety Rumble Strips . . .” 2003). No further information was available at the time this synthesis was being prepared. Oregon has written guidelines; however, they will not be included in this synthesis as they were, at this time, still under review.

Monsere’s presentation concluded, “Data would indicate the rumble strips have been effective at reducing target crashes” (Monsere 2002).



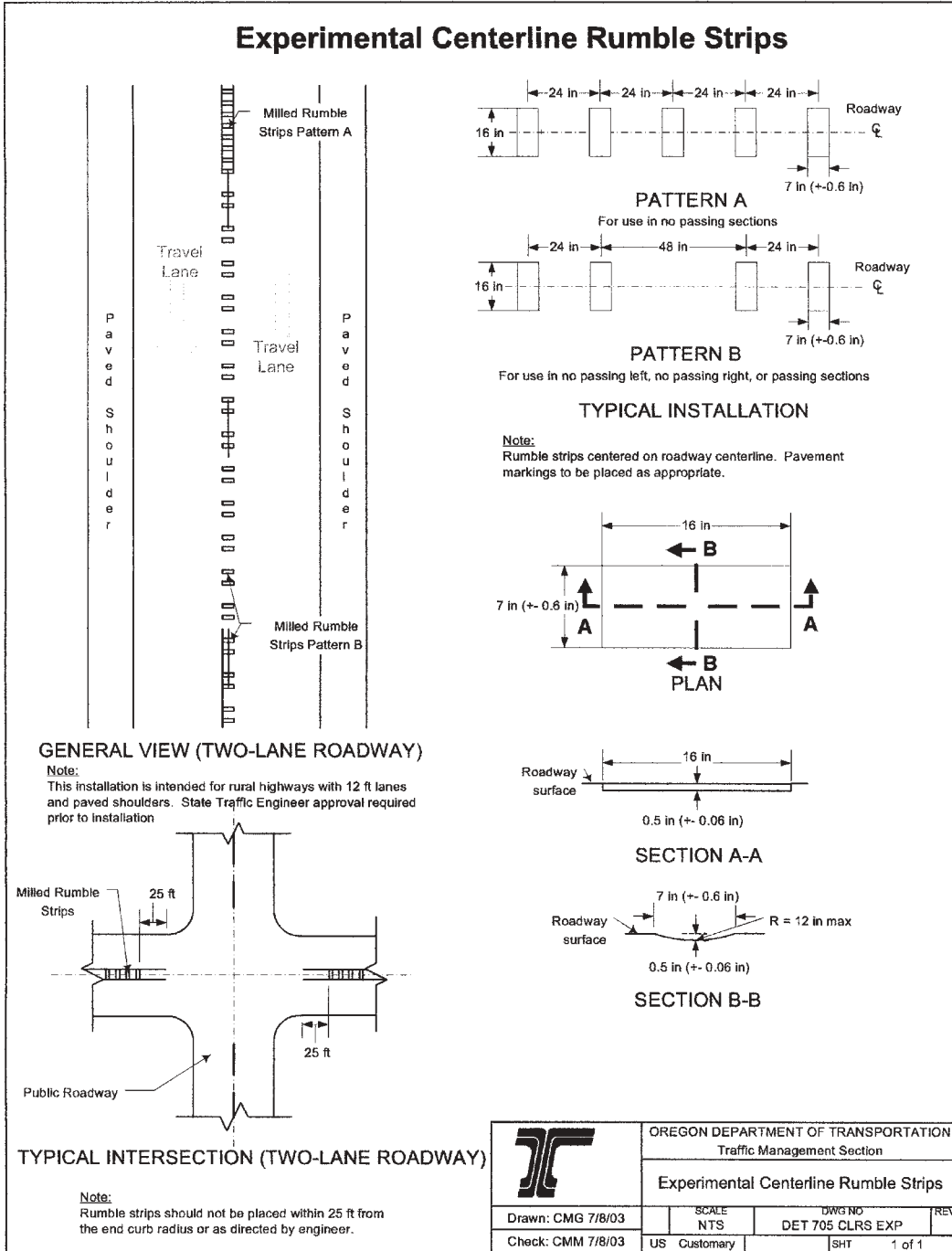

FIGURE 17 Experimental CLRS pattern details (Monsere 2002).

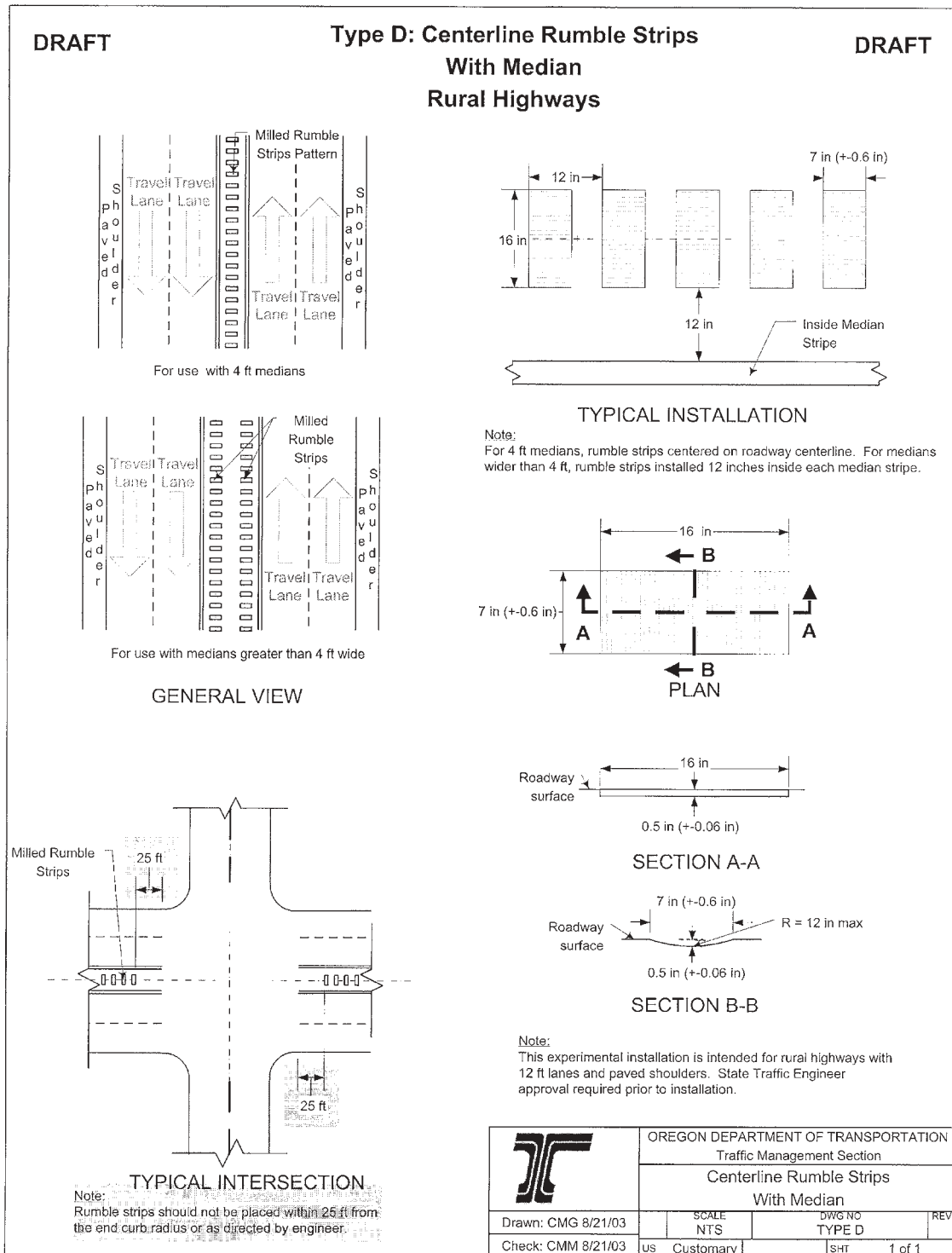

FIGURE 18 Oregon median pattern details (Source: Christopher.M.MONSERE@odot.state.or.us).

## CASE STUDIES

### ALASKA

The Alaska DOT and Public Facilities Research and Technology Transfer conducted a study to learn as much as possible from the Alaska Central Region experiences; documenting successes and problems and making recommendations concerning future installations and research. The specific objectives were as follows:

- Characterize the effectiveness of the rumble strips,
- Define the adverse effects of the rumbles on the traveling public,
- Define the adverse effects of the rumbles on the environment, and
- Define the adverse effects of the rumbles on the department (Adler 2001).

The following CLRS sections were included in the study:

- Section A—Continuous 12-in., milled CLRS placed on Seward Highway along Turnagain Arm on curves of greater than 2 degrees, with most marked for no-passing zones. In several cases, the rumbles overlap into the passing striping. On a new section between Girdwood and Bird Point (MP 90–97), the whole length of the centerline was grooved with rumble strips.
- Section B—Twelve-inch, milled lane line rumble strips, 30 ft long with 10-ft breaks for the existing skip striping, placed on Minnesota Drive from “C” Street to the Old Seward Highway.
- Section C—Eight-inch wide, milled lane line rumble strips, 2 ft long (3 grooves) on 20-ft spacing. This places the rumble strips at the beginning and end of each existing skip stripe. These were placed between the southbound lanes of the Glenn Highway from Hiland Drive to the middle of the weigh station tangent.
- Section D—Six-inch wide, milled lane line rumble strips, 10 ft long with 30-ft breaks. These were centered between the existing 10-ft skip stripes and placed on the southbound lanes of the Glenn Highway from the middle of the weigh station tangent to the middle of the National Guard Armory tangent.
- Section E—Four-inch wide, milled lane line rumble strips, 10 ft long with 30-ft breaks, centered between the existing 10-ft skip stripes and placed in the southbound lanes of the Glenn Highway from the middle of the National Guard Armory tangent to the Ford

Richardson Interchange (identical to section D, except 4 in. rather than 6 in. wide).

There were several other sections of milled shoulder rumble strips.

At that time (2003), information received from Alaska did not include any before or after crash data because the data collection is ongoing. Other preliminary comments and observations paraphrased here were obtained from a presentation (Adler 2001).

- CLRS appear to be effective as lane delineations.
- Sections C and D are preferred by motorists.
- Snow and ice buildup in rumble strips is generally not a problem. One exception is Eagle Rivers Loop Road, a low speed area in a sun shadow where heavy, wet snow packs into grooves and then becomes ice. Snowplows do not remove snow or ice from rumbles.
- Small wheelbase vehicles may have a problem (isolated complaints).
- Rumble strips do not appear to produce an external, measurable volume (db) increase over general traffic noise. However, more research on noise is needed.
- Approximately every other vehicle strikes the CLRS on curves.
- Pavement deterioration is not a problem.
- Debris and snow buildup are not a problem; however, this issue may need more investigation.

The following preliminary recommendations related to CLRS were made (Adler 2001):

- Install additional test sections.
  - They have been received favorably on the Glenn Highway.
  - There is evidence that they are effective for lane delineation.
  - Sections C and D are most favored by motorists.
- Investigate the necessity for the rumble strips. Check historical accidental data and evaluate need.
- If necessary to install rumble strips in residential areas, consider construction of noise barriers and whether investigations on effective noise barriers are necessary.
- Avoid installing rumble strips in low-speed traffic areas. There is a potential for snow and ice buildup.
- Check records on pavement conditions.

- Keep pavement management information system accurate and up to date.
- Do not install rumble strips on joints.
- If necessary, seal cracks before placement.

## MINNESOTA

The Minnesota DOT (MnDOT) installed CLRS on Trunk Highway 23 (TH-23) during the summer of 2000 in an attempt to mitigate an unusually high incidence of head-on traffic crashes. Market research was requested by the MnDOT district involved to determine how the regular users of TH-23 perceived the CLRS. Specifically, the objective of the research was to learn the following:

- Whether the driving public perceives the rumble strips as a safety improvement,
- Whether the rumble strips have caused any vehicle handling problems,
- Whether drivers overreact to the rumble strips, and
- Whether the various segments of MnDOT customers have different perceptions of the rumble strips (Cook Research and Consulting, Inc. 2001).

Focus groups were conducted on June 13, 2001, in Willmar, Minnesota, and June 14, 2001, in St. Cloud, Minnesota, with three groups held in each city. In Willmar, each group consisted of one group of commercial truck drivers and two groups of personal travelers. In St. Cloud, the respondents consisted of one group of personal travelers, one group of commercial truck drivers, and one group of emergency vehicle operators (Cook Research and Consulting, Inc. 2001). The emergency vehicle operators consisted of drivers of state patrol vehicles, ambulances, school buses, etc. Personal drivers were screened to select those who had been driving some stretch of TH-23 between Willmar and St. Cloud at least three times per week for 2 years, which included periods before and after the installation of CLRS. A few motorcyclists were also present in the focus groups. Later, maintenance personnel responsible for the removal of snow and ice along the CLRS segment were interviewed (Cook Research and Consulting, Inc. 2001).

The following discussion of key pros and cons expressed by the participants is paraphrased from the MnDOT, Project M-401 report (Cook Research and Consulting, Inc. 2001).

### Perceptions Before CLRS Installation

TH-23 was troublesome for nearly all focus group participants. Traffic is getting progressively heavier. Many drivers are older adults who drive slowly and cause backups, resulting in more aggressive drivers taking greater risks while passing. There are many businesses along the route and a large number of trucks transporting products to them.

A few of the focus group participants maintain that the only real solution to TH-23 problems is to build a four-lane, divided highway or, if that is not possible, construct bypasses around towns and cities, straighten curves, and build passing lanes.

### Perceptions After CLRS Installation

#### *Personal Travelers' Perceptions*

*Positive Aspects* Most of the personal travelers were convinced that the CLRS has saved lives. One woman who reported falling asleep while driving to work was awakened by the CLRS and was able to correct her driving thus avoiding an accident. She noted that she did not overreact. Another frequent traveler believed that the CLRS saved his life when he was inattentive, drifted over the centerline, was "jarred" back to attention by the CLRS, and corrected his path. Some participants noted that the CLRS give them guidance to the centerline of the road during heavy fog and blowing snow. A few participants felt the CLRS tended to deter unsafe passing. The participants who drive motorcycles stated that they were less likely to pass because they did not want to drive on the CLRS.

*Concerns* The greatest concern expressed by the personal travelers was that a driver unaware of the CLRS might overreact and overcorrect. Another concern was pavement deterioration (potholes are developing along the route). There was also concern expressed that the CLRS were not completely straight; that is, they appeared "squiggly." Some mentioned that the CLRS caused the painted centerline striping to become less visible at night, particularly on rainy nights.

*Summary* As stated in the report, "In total, however, the personal travelers believe that the centerline rumble strips are a valuable addition to the stretch of TH 23 between Willmar and St. Cloud and probably saved a few lives by their presence on the roadway" (Cook Research and Consulting, Inc. 2001).

#### *Commercial Truck Drivers' Perceptions*

*Positive Aspects* The commercial truck drivers believe that the CLRS have saved lives. Many truckers have personally experienced being jolted back to attention by the CLRS. The truckers particularly appreciated the rumble strips during blowing snow and fog. For them, the CLRS have no negative impact or cause any maneuvering problems or loss of control.

*Concerns* The truckers have noticed pavement deterioration and are also concerned about the lessened visibility of the centerline stripes.

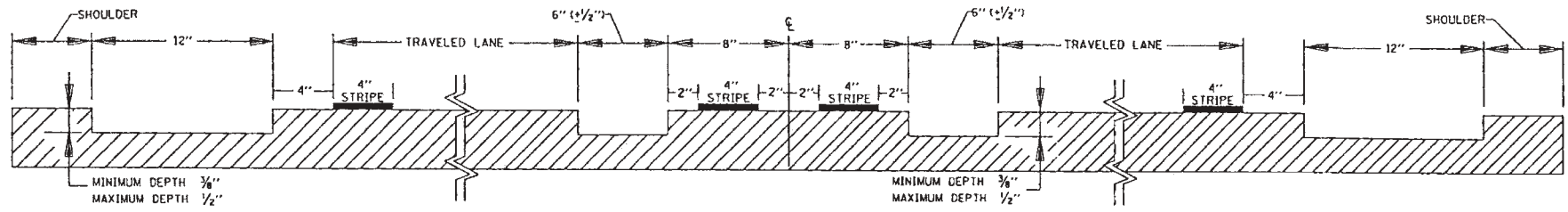

SECTION C-C  
EDGE & CENTER LINE RUMBLE CROSS SECTION

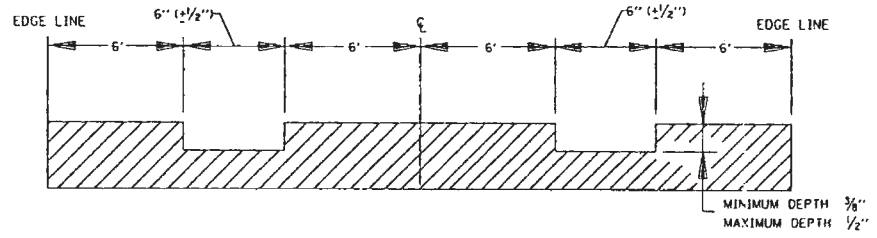

SECTION D-D  
MID LANE RUMBLE CROSS SECTION

FIGURE 19 Redesigned MnDOT CLRS (Cook Research and Consulting, Inc. 2001).

*Emergency Vehicle Operators' Perceptions*

The emergency vehicle operators, in general, believe that the CLRS have created more problems for them than they have provided value for the public. Two members of the Minnesota State Patrol were most critical. They had three major complaints: (1) installing CLRS was a “knee jerk” reaction to the safety problems on TH-23, (2) CLRS are unsafe during high-speed pursuits, and (3) at high rates of speed the CLRS “jarring” disengaged their cruise control. However, the patrol officers were not aware of any crash statistics on TH-23 and stated that if statistics show a safety

improvement they would probably change their negative impressions.

An ambulance driver maintained that it is “difficult and troublesome” to drive an ambulance onto the rumble strips. Two problems were cited: (1) driving the ambulance on CLRS at a high rate of speed causes the vehicle to lurch and unsecured attendants to be thrown around and (2) the jarring of the vehicle on CLRS causes monitors to malfunction; for example, a cardiac monitor will “jump all over the place,” requiring the vehicle to pull over to reset it. Even with the shortcomings noted, however, these operators felt that CLRS

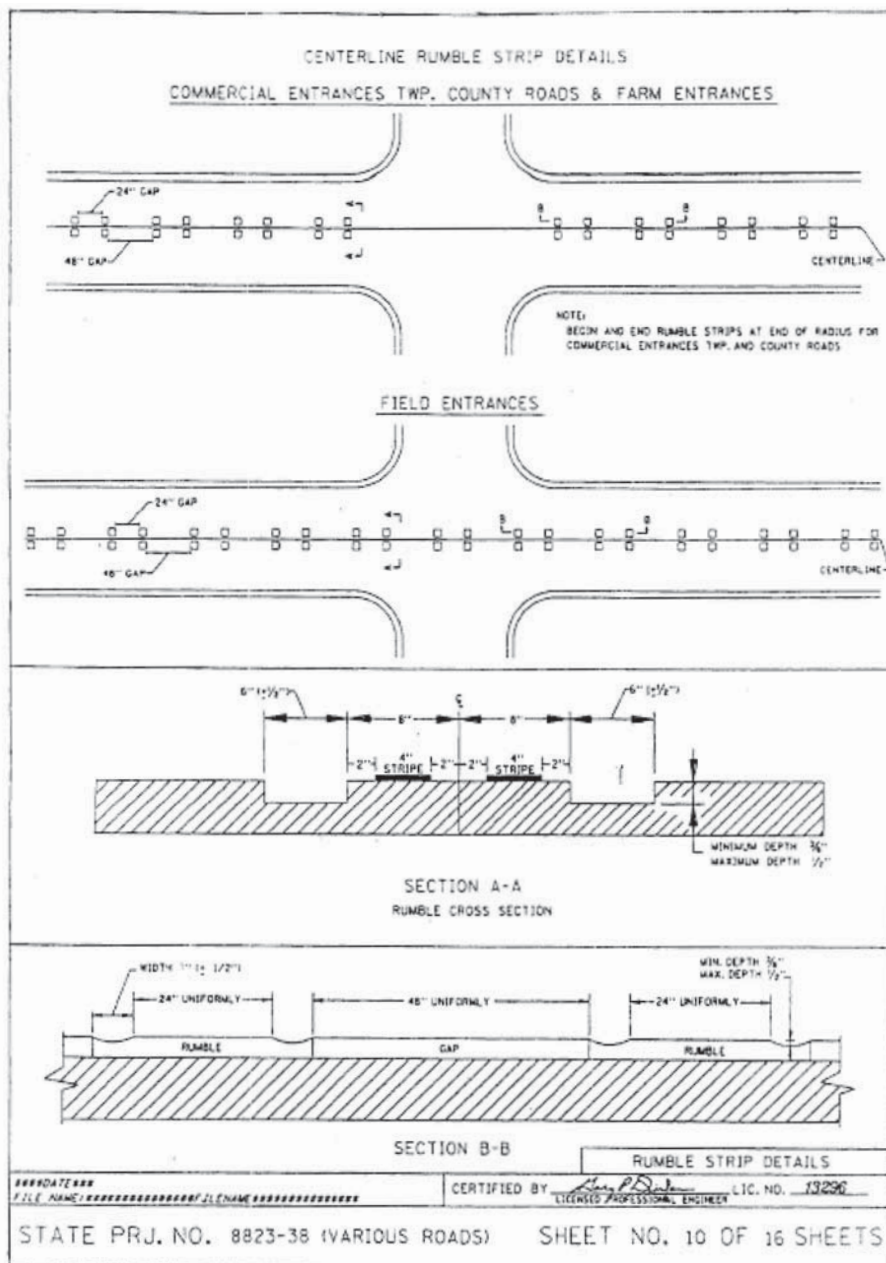

FIGURE 20 MnDOT rumble strip details (Cook Research and Consulting, Inc. 2001).

are of value if they have saved lives (Cook Research and Consulting, Inc. 2001).

### **Maintenance Personnel Discussion**

All participating maintenance personnel reported that CLRS caused problems in the snow and ice removal process; that is, additional passes were required. Some noted that CLRS damaged the underbody of snowplows, requiring additional maintenance.

The report concluded from the discussions that the concerns of snowplow drivers should be considered along with general public comments when future decisions about CLRS are made. The maintenance personnel making positive comments about CLRS felt that they did possibly result in a safer highway. They also made positive comments about possibly

installing the CLRS in a pattern that would not impair the drivers' ability to see the centerline stripes. (See Figures 19 and 20 for a redesigned CLRS that MnDOT will use to address this problem and the problem of pavement deterioration.)

### **Overall Summary of the Focus Group Study**

The following statement from the Focus Group Study provides a good overall summary:

There is no doubt that the drivers on TH 23 feel that the rumble strips have saved lives. They do believe the rumble strips would be more effective if the centerline painted stripes were brighter and more visible. There is a question if the State Patrol can and should adapt their patrolling of the TH 23 to account for the centerline rumble strips. This is probably the major issue that needs to be addressed by MnDOT as they continue to measure the effectiveness of the centerline rumble strips (Cook Research and Consulting, Inc. 2001).

## DISCUSSION OF SURVEY RESULTS—STATE OF THE PRACTICE

### E-MAIL SURVEY

In the spring of 2003, survey questionnaires were e-mailed to DOTs in each of the 50 states, plus Washington, D.C., and 7 provinces in Canada. This survey attempted to determine what past, present, and proposed CLRS projects were being undertaken across most of North America. A copy of this survey can be found in Appendix A.

This survey consisted of eight questions and a request for contact information. Question 1 asked if there were any centerline rumble strips installed on the highway of the receiving state/province/city. If not, the respondents were directed to skip directly to Question 7, thus they only needed to answer Questions 7 and 8 asking them if they knew of any CLRS projects or had ever studied or considered their use. Only those respondents that used centerline rumble strips were instructed to answer Questions 2 to 6.

Fifty-three replies to this e-mailed survey were received, 46 from state DOTs and 7 from Canadian provincial DOTs, an overall response rate of 83%. The list of respondents is provided in Appendix B.

The questions are presented below, followed by a synthesis of key points from respondents' answers.

### SURVEY RESULTS

Question 1: Are there any centerline rumble strips on your highways? Yes \_\_\_\_ No \_\_\_\_

(If "no," please go to Question 7.)

Fifty-four respondents answered this question, with 24 (44%) answering "Yes" and 30 (56%) "No."

Question 2: Design Issues

a. Type of Construction:

Milled \_\_\_\_\_ Rolled \_\_\_\_\_ Ground \_\_\_\_\_

Raised \_\_\_\_\_ Combination(s) \_\_\_\_\_

Seventeen (71%) of the respondents used milled, 2 (8%) rolled, 3 (13%) ground, and 2 (8%) raised types of rumble strips. None of the respondents used combinations.

b. Dimensions—the length varies from 12 in. to 24 in., with 12 in. and 16 in. being used predominantly. The width

varies from 4 in. to 8 in., with 7 in. used predominantly. A summary of the dimensions used by the respondents is given in Table 12.

c. How many miles by type/dimensions?—the answers for this question varied greatly, making any summary meaningless. Total miles reported are given in Table 13.

d. Relation to Roadway

- Continuous or on specific sections—Of the 24 respondents using CLRS, 14 (58%) have continuous strips. Details are provided in Table 14.
- Where are the rumble strips in relation to the longitudinal joint and centerline?—The answer to this question was highly specific and it varied from one respondent to another. The results are compiled in Table 15.
- Did you have to adjust lane width because of the rumble strips?—Nineteen of the 24 respondents (79%) did not have to adjust the lane width because of the rumble strips. Kentucky reported that all CLRS had been installed on existing roads with 12-ft lanes; therefore, effective lane width was reduced accordingly. Rhode Island reported that four 11-ft lanes were changed to two 12-ft lanes, with 6- to 8-ft shoulders and a 4-ft median.

e. What type of material do you use for centerline markings?—Paints were used by most of the respondents, with 14 using paints of some kind. The rest either used thermoplastic or a combination of paints and thermoplastics (details are given in Table 16).

f. Do centerline rumble strips reduce nighttime retroreflectivity of the material?—Fourteen (58%) of the 24 respondents answered that there was not any reduction in nighttime retroreflectivity because of using the CLRS. Four respondents—Massachusetts, Michigan, Minnesota, and Oregon—answered "Yes." Six respondents answered "Can't say." All answers were based on subjective evaluation. No data were mentioned.

Question 3: Operational Effects (cars, trucks)

a. Do you have any evidence or opinion of driver reactions to rumble strips on their left; for example, some people



TABLE 12  
DETAILED DIMENSIONS OF CLRS AS REPORTED BY RESPONDENTS

State	Dimensions			
	Length <sup>a</sup>	Width <sup>b</sup>	Depth	Edge-to-Edge Spacing
Alabama				10 in.
Alaska	12 in.	5–7 in.	0.5 in.	5 in.
Alberta	12 in.	6–8 in.	0.2–0.35 in.	6–8 in.
Saskatchewan <sup>c</sup>	12 in.	5–7 in.	2 in.	7 in.
	12 in.	4–6 in.	0.4–2 in.	6–7 in.
California <sup>d</sup>				
Colorado	12 in.	5 in.	3/8 in.	7 in. = 12 in. on center
Delaware	16 in.	7 in.	0.5 in.	12 in.
Hawaii	18–24 in.	4 in.	N/A	20 in.
Kansas <sup>e</sup>	12 in.	6.5 in.	0.5 in.	Type 1: 12 in., Type 2: 12 and 24 in.
Kentucky	24 in.	7 in.	0.5–5/8 in.	17 in.
Maryland	18–24 in.	4 in.	0.5 in.	varies
Massachusetts	16 in.	6 in.	0.5 in.	12 in. on centers
Michigan	16 in.	7 in.	3/8 in.	12 in.
Minnesota	12–16 in.	7 in.	0.5 in.	12 in.
Missouri	12 in.	6.5 in.	0.5 in.	6 in.
Nebraska	16 in.	7 in.	0.5–5/8 in.	5 in.
Oregon	16 in.	7 in.	0.5 in.	12 in.
Pennsylvania	16 in.	7 in.	0.5 in.	4 in.
Rhode Island	16 in.	7 in.	0.5 in.	5 in.
Utah	12 in.	8 in.	5/8–3/4 in.	4 in.
Virginia	16 in.	6 in.	0.5 in.	12 in.
Washington	16 in.	5 in.	3/8 in.	7 in.
Wisconsin	dimensions are irregular		1.25 in.	none reported
Wyoming	12 in.	7.5 in.	0.5 in.	7 in.

Note: N/A = not available.

<sup>a</sup>Length represents dimension perpendicular to travel surface centerline (see Figure 1).

<sup>b</sup>Width represents dimension parallel to travel surface centerline (see Figure 1). In some cases, reported width and length were the opposite of the definition used in this synthesis (Figure 1) and changed accordingly.

<sup>c</sup>The first and second row represents two- and four-lane sections, respectively.

<sup>d</sup>Currently, there are no standards regarding the dimensions.

<sup>e</sup>Kansas uses center-to-center and not edge-to-edge dimensions. Type 1—continuous: 12 in. on center; Type 2—alternating: 12 in. and 24 in. on center.

TABLE 13  
MILES AS REPORTED BY RESPONDENTS

Respondent	Distance
Alabama	<5 mi
Alaska	15 mi
Alberta	19 mi
Saskatchewan	4.35 mi
California	approximately 300 mi
Colorado	39 mi
Delaware	2.9 mi
Hawaii	0.30 mi/undivided and 0.25 mi/divided roadway
Kansas	Type 1: 8 mi and Type 2: 7 mi
Kentucky	90 mi
Maryland	approximately 25 mi
Massachusetts	9.5 mi
Michigan	7 mi
Minnesota	approximately 90 mi
Missouri	4 mi of each pattern
Nebraska	16 mi
Oregon	<50 mi
Pennsylvania	approximately 300 mi
Rhode Island	approximately 4 mi
Utah	approximately 13 mi
Virginia	2 mi
Washington	70 mi
Wisconsin	<0.5 mi
Wyoming	15 mi

fear it results in drivers jerking the wheel to the left?—Of the 24 respondents using CLRS, 17 (71%) reported that they have no evidence or opinion of jerking the wheel left, and 3 answered “Can’t say.” The four respondents that reported “Yes” were Maryland, Michigan, Pennsylvania, and Saskatchewan. Saskatchewan maintenance staff commented that the gore point signs on the two- to four-lane transitions are not hit as often. Maryland’s opinion is that there is no significant effect. One of the newspapers in Michigan, after surveying local drivers, printed an article

TABLE 14  
NUMBER OF RESPONDENTS  
REPORTING USE OF RUMBLE  
STRIPS ON CONTINUOUS OR  
OTHER SPECIFIC SECTIONS

Continuous/Specific Sections	No. of States
Continuous	14
Specific sections	3
No-passing zones	4
Curves	2
No response	1

TABLE 15  
LOCATION OF THE RUMBLE STRIP IN RELATION TO LONGITUDINAL JOINT AND  
CENTERLINE AS REPORTED BY RESPONDENTS

Respondent	Location Related to Longitudinal Joint and Centerline
Alabama	RPM placed on either side of double yellow centerline stripe
Alaska	On centerline, adjacent to joint where possible
Alberta	On centerline and therefore generally on the longitudinal pavement joint
Saskatchewan	At center of road, rumble strips are placed directly over the centerline; there is usually also a longitudinal joint on the centerline
California	Varies by location and depends on site-specific characteristics
Colorado	In the centerline
Delaware	Located on the centerline, both passing and nonpassing
Hawaii	On both sides of the longitudinal joint and centerline
Kansas	Centered over joint and lane lines
Kentucky	Centerline strip centered over joint, stripe centered on centerline strip
Maryland	Straddles both
Massachusetts	Rumble strips straddle the center of roadway
Michigan	Rumble strip milled on longitudinal center joint
Minnesota	Generally on the centerline, but offset from construction joint
Missouri	To be installed in center of roadway with the centerline and longitudinal joint
Nebraska	Centered down the centerline
Oregon	In painted medians, placed 300 mm inside painted stripes
Pennsylvania	See attached guideline and detail file (Appendix C)
Rhode Island	Along centerline
Utah	On double yellow and widened median they straddle the paint lines
Virginia	Center of the road
Washington	On centerline and longitudinal joint
Wisconsin	Centered on longitudinal joint (centerline)
Wyoming	Milled into the center of the roadway

Note: RPM = raised pavement marker.

in which it reported that the effect of CLRS is favorable (personal communication, J.G. Morena, Pavement Marking Engineer, Michigan DOT, 2003). Pennsylvania attached the study, *Evaluation of Centerline Rumble Strips on Lateral Vehicle Placement and Speed on Two-Lane Highways* (Mahoney et al. 2003). Findings from this study are summarized in chapter two.

- b. Does the reduced drivable area or drivers crossing the centerline create any passing or operational problems?—Nineteen respondents (of 24) indicated that the reduction in drivable area does not create any passing or operational problems; in two cases there were problems, and three respondents answered “Can’t say.”
- c. Are there problems with water accumulating in the rumble strips, either for drivers or for pavement deteriora-

tion?—Fifteen respondents (of 24) answered that there is no effect on pavement deterioration or problems for drivers because of water accumulation in the rumble strips, two answered that they have problems, and seven respondents replied “Can’t say.” The two respondents that answered “Yes” were Alaska and Oregon. Alaska reported that it has noted pavement deterioration only when rumbles were installed in chip seals or otherwise compromised pavements. It also commented that sometimes snow or ice will compact into rumbles and persist for a short time after a storm, but that traffic eventually clears them if they are exposed to it. Oregon responded that water accumulation can lead to premature pavement deterioration.

- d. Are you aware of any complaints from residents about noise from the rumble strips?—Fifteen respondents noted that there were no complaints from residents about noise, but this can also be because these respondents have the rumble strips in places away from residential areas. Seven respondents have faced some problems regarding noise complaints from residents; the nature of these problems is given in Table 17. Two respondents answered “Can’t say.”

TABLE 16  
TYPES OF MATERIALS REPORTED BEING USED FOR  
CENTERLINE MARKING

Materials	No. of Respondents
Epoxy paint	4
Other paints*	10
Thermoplastic	2
Combinations of two or more of above	7
Raised pavement markers or dome buttons	1

\*Includes water-borne paint, methyl methacrylate, standard traffic paint, low volatile organic compound (VOC) paint, alkyd paints, retroreflective paint, and used paint.

#### Question 4: Operational Effects (motorcycle, bicycles)

- a. What has been the response of the motorcycle community regarding the centerline rumble strips?—Twenty-

TABLE 17  
NOISE PROBLEMS AS REPORTED BY SURVEY RESPONDENTS

Respondent	Details of Problem
Alaska	If rumbles are installed near residential or other noise-sensitive areas we receive numerous complaints, but these complaints seem to diminish as people become accustomed to the noise—which does not appear to be louder than background traffic noise. However, the sound is very distinguishable from background traffic noise.
California	For shoulder rumble strips: At an urban area location, the noise created by vehicles traveling over shoulder rumble strips, bounced off the adjacent soundwall and traveled over to the opposite side of the roadway and up a hill where there was a private residence. The rumble strips were removed.
Nebraska	We have had one or two complaints of noise from residents.
Pennsylvania	We have come up with guidelines, which are attached (see Appendix C).
Saskatchewan	In one instance, shoulder rumble strips were installed too close to a residence. Readings in the front yard of the residence, which was located over 80 m from the rumble strips, was in the 82 decibel range.
Wisconsin	Immediately after construction there were some complaints. Existence of recent complaints is unknown.
Wyoming	No details provided.

two respondents reported that they had not received any complaints or responses from the motorcycle community. One respondent reported a positive response, and one a negative response. Alaska has received complaints from motorcyclists who perceive an adverse affect on control because of the rumble strips but noted that there is no evidence to support this claim. Utah noted that.

The existing installation does not have much potential for interaction with the motorcycle community. There are not any passing areas allowed. However, in the installation for summer 2003, there will be areas where passing is permitted, and there will be rumble strips placed. We are providing a gap in the strips to facilitate motorcyclist to maneuver through. The ultimate size of the gap and the spacing will be determined after the evaluation this summer, which will review this issue (personal communication, j.leonard@utah.gov).

- b. What has been the response of the bicycle community regarding the centerline rumble strips?—Twenty-one respondents reported that they had not received any complaints or responses from the bicycle community. The three states that have received some complaints were Colorado, Pennsylvania, and Wyoming. All three states reported complaints that drivers crowd cyclists on the right side of the roadway rather than move left across the rumble strip when passing the bicyclists.

#### Question 5: Safety

What before-and-after crash data do you have on the sections where the rumble strips have been installed? (If no data, do you have any indications; for example, observations regarding positive or negative effects?) The answers to this question were highly specific and varied from respondent to respondent. It appears that long-term, reliable crash data

are scarce. The detailed responses of each respondent are given in Table 18.

#### Question 6: Policy

Do you have any policy regarding roadway cross section, speed, etc., for which you would or would not install centerline rumble strips?—Twenty of 24 respondents (83%) did not have any policies, whereas 4 had some guidelines or policies relating to installation of CLRS. Four states, California, Oregon, Pennsylvania, and Utah, sent copies of policies or guidelines (see Appendix C).

#### Question 7: Case Studies

Do you have or know of any projects with documented information we could use for a case study?—Eight respondents (Alaska, California, Colorado, Michigan, Minnesota, Missouri, Nebraska, and Pennsylvania) had some projects or knew about others that had some projects and documented information, 15 did not have any information, and 1 replied “Can’t say.” Information from these states is summarized in chapters two and three.

#### Question 8: Studies

Have you ever studied or considered using centerline rumble strips in your state?—Of the respondents that reported using CLRS, 17 say they have conducted a study before using CLRS, 7 reported they had not conducted any formal studies. In addition to the respondents that reported using CLRS, the respondents that answered “Yes” were Arizona, Calgary, Connecticut, Indiana, Iowa, Maine, Manitoba, Montana, Quebec, South Carolina, South Dakota, and West Virginia. (This question was intended only for those states not having CLRS; however, this apparently was not clear.)

TABLE 18  
BEFORE-AND-AFTER CRASH DATA AS REPORTED BY RESPONDENTS

Respondent	Before-and-After Crash Data
Alabama	Positive effect
California	DOT maintains a collision database that includes collision and travel data for all state highways
Colorado	Before: 18 H-O and 24 S-S; after: 14 H-O and 18 S-S
Delaware	Total: Before: 13/yr, after: 12/yr H-O; before: 2/yr, after: 0.1/yr
Kentucky	No significant difference
Maryland	All positive; we have data
Michigan	Three-year before data indicated a slightly higher than average H-O/S-S opposite crash history. No after data available yet
Minnesota	Compiled before/after data for 87 mi of roadway with CLRS
Missouri	We have gathered the before crash data for a test section
Nebraska	Before: 18 crossover; After: limited data
Oregon	General positive effect on the two corridors where installed
Saskatchewan	Before: 2 H-O and 1 S-S; After: none
Utah	Before: 11; After: 3
Virginia	Before: 1 H-O, 2 S-S; After: 1 H-O, 2 S-S
Washington	45%–55% reduction in cross-over crashes
Wyoming	CLRS were installed in single location—US-287 south of Laramie in Fall of 2003

Notes: The following respondents reported none: Alaska, Alberta, Hawaii, Kansas, Massachusetts, Pennsylvania, Rhode Island, and Wisconsin. H-O = head-on crash; S-S = sideswipe crashes (assumed opposite direction).

## SUPPLEMENTARY SURVEY

Although the survey of states and Canadian provinces disclosed four states with documents presented as policy or guidelines, no warrants were uncovered. The lack of warrants was considered to be a concern. Therefore, a supplementary questionnaire was sent to all 54 of the original respondents. This section presents the questions and the results.

### Supplementary Survey Questions

The following questions were e-mailed to the 54 respondents to the original survey:

1. Should there be warrants for the use of CLRS?
2. If yes, what should the units be; for example, two fatalities per 100 miles per year or what?
3. If no, what should the decision to use CLRS be based on; that is, what does your state base it on or, if not available, what would you base it on if it was your decision?

### Supplementary Survey Answers

There were a total of 18 responses, 14 from U.S. states, which included 12 with CLRS and 2 that were considering CLRS, and 3 from Canadian provinces, including 2 with CLRS. Considering the total of 54 potential replies, the results (33%) could be considered disappointing. However, only 22 U.S. states and 2 Canadian provinces have CLRS, and 14 of these (58%) responded. This was considered to be a reliable cross section of CLRS states.

The following is a summary of the results of the supplementary survey.

Question 1: Should there be warrants for the use of CLRS?

Thirteen (72.2%) answered “no.” Two (11.1%) answered “yes.” Two (11.1%) did not answer question one. One (5.6%) answered that it was “indeterminate.”

Question 2: If yes, what should the units be?

Of the two respondents that answered “yes” to question one, one answered they should be “two pronged—reactive and proactive.” The other answered “not sure.”

Question 3: If no, what should the decision to use CLRS be based on?

The responses are summarized here (three respondents did not answer this question).

- We would rather see guidance. Installed based on a critical rate ratio. (No explanation of critical rate ratio was provided.)
- Pavement marking visibility on wet nights. Not in residential or urban areas.
- A demonstrated need based on crash experience or perceived need based on safety concerns. A 1,500 ADT threshold is suggested.
- AADT and societal benefits owing to crash reduction.
- On two-lane roadways that have either (1) already experienced a high density of head-on or ROR to the left

crashes or (2) have high volumes that increase the probability of cross-over crashes. Proposed legislation in Minnesota would mandate CLRS on all state highway and county state-aid highway projects.

- Geographic information systems plot of the location of cross-over crashes not involving a passing maneuver.
- Safety enhancements should be marketed, not mandated.
- Based on crash data, location, and traffic engineering input.
- Sound engineering judgment considering traffic volumes, alignment crash rates, crash types, etc.
- Develop design guidelines for agency consistency considering noise, collision experience, and geometrics.
- Based on sound engineering judgment of local and regional conditions.
- Review the number of roadway departures versus state-wide averages.
- Consider in sections with higher traffic volumes where crossing centerline is not permitted.
- There should be guidelines based on information from others regarding where CLRS are appropriate and where they are not.
- CLRS should be based on engineering judgment and some [unspecified] pattern of cross-over collisions.

### Supplementary Survey Summary

- The majority (58%) of these states and provinces using or considering CLRS do not think warrants are appropriate. Only two respondents (11.1%) answered “yes” to this question and only one of the two (Missouri) provided a draft (see Appendix C).
- Most respondents, representing a majority of states using CLRS, prefer guidelines to warrants. Those replying suggested that the content of the guidelines should be based on “engineering judgment.” As a result of the supplementary survey, Minnesota sent a “white sheet” report on its CLRS activities and draft guidelines (see Appendix C).

### SURVEY CONCLUSIONS

Replies to the main survey were received from 54 respondents (46 states, Washington, D.C., and 7 Canadian provinces). Below are the conclusions that can be made from the responses.

#### Extent of Use

- Twenty-four respondents (44%; 22 states and 2 provinces) used CLRS.
- The number of miles of CLRS reported in a 2003 survey had greatly increased since a 2000 survey, but only two additional states and one province have implemented CLRS.

- Fourteen of 24 respondents reporting the use of CLRS used continuous CLRS; that is, in both passing and no-passing zones. The rest (10) reported using them only in no-passing zones (4), on curves (2), or on specific sections (3), and one did not answer this question.

#### Design Issues

- Type: Milled CLRS are preferred by those states using CLRS.
- Length: The length (perpendicular to the centerline) of the rumble strips varies from 12 in. to 24 in., with 12 in. and 16 in. being used predominantly.
- Width: The width (along the centerline) varies from 4 in. to 8 in., with 7 in. used predominantly.
- Roadway width: Increasing the roadway width for CLRS is not a major issue (19 of 24 respondents).
- Striping type: Paints are used predominantly as the material for centerline markings.

#### Safety Issues

- Retroreflectivity: Most respondents (14 of 24) did not have any problem with reduced nighttime retroreflectivity. Anecdotal evidence suggests that CLRS increase nighttime visibility in wet conditions.
- Vehicle operation: Seventeen of the 24 respondents reported that there was no evidence or opinion of jerking the vehicle to the left.
- Passing: Most respondents (19 of 24) reported that the reduction in drivable area does not create any passing problems.
- Motorcycles: Twenty-two of the respondents reported that they had not received any response from the motorcycle community.
- Bicycles: Twenty-one of the 24 respondents reported that they did not get any response from the bicycle community.

#### Policy, Guidelines, Warrants

- Guidelines: Only four of the 24 respondents (California, Oregon, Pennsylvania, and Utah) provided policies or guidelines for installation of CLRS (see Appendix C).
- Warrants: No respondents reported having any warrants.

#### Maintenance Issues/Concerns

- Pavement deterioration: Most respondents (15 of 24) reported that there was not any effect of pavement deterioration because of water accumulation.
- Noise: Fifteen respondents (15 of 24) did not have any noise complaints from residents.

- Snow plowing: Operators of snow-plowing equipment in one state expressed concerns about increased wear on their equipment.

#### **Conclusions from Supplementary Survey**

- There should not be warrants for the use of CLRS.
- There should be guidelines based on engineering judgment, which considers such factors as:
  - Number of crashes,
  - Crash rate,
  - Number of cross-over crashes,
  - ADT,
  - Type of roadway,
  - Location of roadway,
  - Local and regional conditions,
  - Roadway alignment,
  - Consistency within state, and
  - Experience of others.

## KEY ISSUES AND ANALYSIS

### CENTERLINE RUMBLE STRIP EFFECTIVENESS

Most information on CLRS obtained from published and unpublished literature, a nationwide survey, and personal contacts was positive, and the available body of evidence suggests they reduce cross-over crashes on two-lane roadways and save lives. Although there are some negative aspects to their installation, the positive aspects appear to far outweigh the negative ones. Analysis should continue and more studies should be conducted to address the negative points, such as centerline marking visibility; pavement deterioration; effects on motorcycles; risk to bicyclists, particularly on roadways with narrow or no shoulder; and the effects of noise on residences.

### EXTENT OF CENTERLINE RUMBLE STRIP USE

In the interval between the two surveys, in 2000 and 2003, the number of states with CLRS only increased from 20 to 22 and the number of Canadian provinces from 1 to 2; however, the number of miles of CLRS increased considerably. In 2000, the maximum number of miles in any state was 15. In 2003, there was one state with 300 mi, and the total miles of all states using CLRS increased significantly to more than 2,000. Several states reported having only a few miles of CLRS in 2003, indicating the tendency to still be experimental. Six states indicated they had no interest in CLRS. Most states that have not installed or have not considered using them appear to be waiting for more “evidence.”

### COMPILATION OF POSITIVE FINDINGS

- Several states using CLRS reported a reduction in overall, targeted (cross-over), injury, and/or fatal crashes.
- A report setting forth guidance for implementation of the AASHTO strategic safety plan cited positive reviews of CLRS for reducing crashes in three states and found no significant negative effects.
- A Pennsylvania study reported that PennDOT believed that the safety effectiveness of CLRS was well documented.
- A Delaware study on 2.9 mi of CLRS reported a cost-benefit ratio of 110.
- The overall conclusion of a comprehensive three-phase study conducted in Massachusetts was that CLRS are a recommended countermeasure in areas where cross-over crashes occur.

- Although the quality of the statistical analysis used in the studies that report crash reductions is, in most cases, unknown, a comprehensive study using reliable data available from seven states and state-of-the-art statistical methodology found that overall vehicle crashes were reduced by an estimated 15%, injury crashes by an estimated 15%, head-on and opposing-direction crashes by an estimated 21%, and head-on and opposing-direction sideswipe crashes involving injury by an estimated 25%. Available data were insufficient to make any conclusions about reductions in fatal crashes.
- In a Kansas study, 96% of the respondents felt that installation of CLRS would reduce crashes. Minnesota also reported driver satisfaction with CLRS.
- Benefits beyond safety were also reported by some states.

### COMPILATION OF NEGATIVE FINDINGS

No reliable evidence of negative effects was uncovered; however, there are several concerns that have not yet been proven, disproved, or, in some cases, adequately studied:

- Danger to bicyclists,
- Effect on motorcycles,
- Roadside noise complaints,
- Drivers reacting to the left,
- Pavement deterioration,
- Effect(s) on different types of pavement material,
- Striping visibility,
- Increased snowplow wear,
- Limited after data,
- Effect(s) on emergency vehicles,
- Lack of widely accepted guidelines, and
- Water, snow, and ice accumulation.

### RELATIONSHIP OF KEY ISSUES TO SYNTHESIS SCOPE

The following summarizes the consultants’ findings categorized by specific topics listed in the synthesis final scope.

#### Warrants

No warrants were uncovered in the literature review, original survey, or personal contacts. Five states sent policies or guidelines (California, Minnesota, Oregon, Pennsylvania, and

Utah). These are presented in Appendix C. To ensure that nothing was missed, a supplementary survey specifically addressing warrants was distributed to all 54 original survey respondents. Although there were only 18 replies, they represented a majority of the states and provinces that have CLRS (14/24 or 58%). Thirteen of the 18 respondents answered that warrants were not appropriate for CLRS. Those not in favor of warrants generally favored using “engineering judgment” for specific sections. Two answered “yes” and one, Missouri, sent draft warrants (see Appendix C). A detailed summary of the supplementary survey, including comments regarding warrants, is presented in chapter four.

Commonalities found in the draft policy, guidelines, and the draft warrants are as follows:

- Roadway type—Rural two- or three-lane undivided;
- Crash history—All documents address numbers of crashes or crash rates and indicated that CLRS should be used on sections where some number (unspecified) of cross-over crashes have occurred. Only California policy contains a specific, weighted average number based on a value for various levels of five categories: number of total crashes, number of deaths, fatal accident rate, death rate, and total accidents per mile. The five categories are summed and a value of 40 (plus a cross-over fatality during 1998) triggers an investigation of the site;
- Speed—50 mph or greater;
- ADT threshold—1,500 to 3,500;
- Lane width—No less than 10 ft, with 11 or 12 ft more common;
- Pavement type—Primarily asphalt in good condition with minimum depths of 2.5 in. to 2.75 in.;
- Noise—Consider noise; and
- Coordination—Coordinate with all other project tasks and install CLRS last.

## Design

There is no standard design. Current designs by all 54 states and provinces responding to the survey are detailed in chapter four. The most common types are milled, 12 in. to 16 in. long (perpendicular to the centerline), 7 in. wide (along the centerline), ½ in. deep, with the two most common patterns being continuous, with rumblestrips 12 in. to 24 in. apart, or alternating, with pairs of rumble strips 12 in. or 24 in. apart with the pairs being 24 in. or 48 in. apart, respectively. Kansas is the only state that reported research on vibration and noise and concluded that either the continuous 12 in. or alternating pairs 12 in. apart with the pairs 24 in. apart provided the optimum, required response to alert drivers. Oregon has a unique section in a 4-ft median with the painted stripes outside of the rumble strips. Minnesota has a unique section with the rumble strips outside of the painted centerline stripes.

## Operational Effects

The main question regarding operational effects is whether drivers are so conditioned to right-side, shoulder rumble strips that they will jerk the wheel to the left when encountering CLRS. The consultants found no clear evidence that this potentially dangerous action would occur. One Massachusetts simulator study found that 27% of subjects did steer to the left. The researchers of the Massachusetts study concluded that although the result could have been the result of conditions inherent in simulator studies, the possibility exists and should be further studied. It should be noted that in the Massachusetts study the subjects were first exposed to right shoulder rumble strips and CLRS. No left shoulder rumble strips, which the consultants believe are now as common as right shoulder rumble strips, were introduced in the study. Also, in the study, the vibration was transmitted through the vehicles’ seat, whereas in reality vibration is transmitted through the steering wheel.

Other operational issues uncovered by the consultants involve lane placement, speed, level of service, and weather conditions. There was one Pennsylvania study that found that there was a movement of vehicles away from the CLRS on the order of several inches. This movement would increase the separation of opposing vehicles and potentially increase safety. A potential negative effect would be on routes where there are bicyclists. Bicyclists claim vehicles on roads with CLRS hesitate moving left and create a potentially dangerous situation for them. Bicyclists are particularly concerned on winding roads and roads with no shoulder. This effect needs more study and certainly should be considered in any decision to use CLRS.

No studies or information were uncovered regarding the effects on speed or level of service.

In regard to weather conditions, the little information uncovered was positive. Focus groups in Minnesota indicated that CLRS were helpful in identifying the roadway centerline during adverse weather, like blowing snow. Only one instance of water or ice being a problem was uncovered, and this was on an Alaskan highway section that never was exposed to sun.

## Effects on Crashes

The body of evidence uncovered leads to the conclusion that CLRS are an acceptable countermeasure to reduce cross-over crashes, injuries, and fatalities. Crashes are in reality a rare occurrence and, for a given roadway segment, several years of data or several combined databases are generally required to apply sophisticated statistical techniques that produce statistically significant results indicating that a treatment resulted in an effect caused by the treatment and not by chance. In the case of CLRS, the effect of interest considered as evidence that CLRS had a positive effect is reduced cross-over crashes.



Several states reported decreases in cross-over crashes as a result of the installation of CLRS. Most did not claim statistically significant results; and, with two exceptions, information available to the consultants was insufficient to determine the quality of the data or the statistical methodology. It should be noted that lack of a statistically significant result does not always mean there is none; the data available may simply be insufficient. It is possible that some results are inflated; however, in all cases uncovered, the trends were positive. In all cases, the trends showed decreased cross-over crashes. These trends and the IIHS study in which statistical experts used state-of-the-art statistical techniques and combined data from seven states and concluded that there were statistically significant reductions in all cross-over crashes and injury crashes as a result of CLRS installation support the conclusion that CLRS are effective in reducing CLRS crashes.

### Impacts on Bicyclists

The most negative information uncovered in regard to bicyclists was from Colorado. Bicyclists and bicycle organizations in Colorado actively oppose CLRS, particularly on winding mountain roads and roads with no shoulder. This issue needs to be considered and studied further. Two other states mentioned concerns.

### Maintenance

Although no clear evidence was uncovered, there is definitely the possibility that CLRS milled over the centerline could increase or accelerate the typical centerline pavement joint. Minnesota uses a unique section with the rumble strips milled outside of the centerline strips. Long-term research is needed. At a minimum, CLRS should be installed only in good pavement. In Minnesota, maintenance personnel have brought

up issues related to additional wear on snow removal equipment. This issue needs to be addressed by individual states.

### Cost

It is very difficult to get good, accurate, cost data. This appears to be because CLRS are not usually installed alone, but as the final operation in a series of improvements to a roadway section. The consultants consider the estimate of Dustrol to be the most reliable because Dustrol only does CLRS installation. The \$0.26 to \$0.85 per linear meter cost appears reasonable.

### Other Issues

- Motorcycles—nothing beyond limited anecdotal information was uncovered. This information indicated that CLRS were not a problem with motorcyclists.
- Centerline strip visibility—This is an indeterminate issue. Information is anecdotal, and as many persons who say centerline visibility is decreased when placed over CLRS, as many more say visibility is enhanced. There is subjective agreement that CLRS enhance centerline strip visibility in wet weather and rainy conditions. One opinion expressed to the consultants was that paint sprayers placing paint over CLRS tend to put a heavier coat on one side of the milled rumble strip. This condition may make them more visible in one direction than the other and should be investigated.
- Noise—External noise toward roadsides and its effect on roadside residences should be considered. Many responses noted it should be considered, but no definite numbers were presented except in a TAC report that states CLRS terminated 200 m before residential or urban areas produce tolerable noise impacts on residents and that at 500 m the noise is negligible.

## CONCLUSIONS AND SUGGESTIONS

The following conclusions were derived from the main issues uncovered while developing the synthesis:

- Centerline rumble strips (CLRS) are an effective safety countermeasure for reducing overall and injury cross-over crashes on two-lane, two-way roadways.
- States and provinces with CLRS should continue to monitor the CLRS sections and expand their safety databases after CLRS installation.
- State-of-the-art statistical analysis procedures should be studied, promoted, and used on the before-and-after analysis of CLRS sections.
- No conclusive evidence of negative effects of CLRS were found; however, several concerns or potential negative effects have yet to be proven or refuted, particularly the safety effect on bicyclists, and need additional study.
- *Manual on Uniform Traffic Control Devices*-type warrants such as those for highway signing, are not appropriate for CLRS; guidelines are preferred.
- For consistency within a state or agency, CLRS guidelines should be developed based on engineering judgment considering such things as traffic volume, numbers and/or rates of cross-over crashes, roadway type, geometry and location, regional conditions, and experience.

Based on survey results, the following suggestions for future research are made:

- Continue longer-term evaluation of the CLRS that have been installed.
- Develop and promote a proper, standardized methodology for analyzing the safety effectiveness of CLRS.
- Develop and widely disseminate additional training material and/or a course in proper statistical methods for analyzing the results of highway safety treatments.
- Conduct research and monitor CLRS locations for long-term pavement performance on various pavement types.
- Conduct research on the long-term effect of CLRS nighttime visibility of striping on dry and wet pavements.
- Study the effects of CLRS on bicycle safety on two-lane roads with no or limited shoulder and bicycle use.
- Conduct additional research to determine if CLRS provide a clear, easily understood message to the driver.
- Determine if CLRS are more cost-effective if continuous or if only in no-passing zones.
- Determine whether the accumulation of water, snow, or ice is an issue with CLRS.
- Develop guidelines regarding CLRS installations.

## REFERENCES

- Adler, C., *Evaluation of Rumble Strips in Alaska*, Research Project, Alaska Department of Transportation and Public Facilities Research and Technology Transfer, Anchorage, 2001.
- Alexander, J. and P. Garder, *Continued Research on Continuous Rumble Strips*, Final Technical Report 94-4, Maine Department of Transportation, Augusta, 1995.
- Brin, T.S., *Reducing Crossover Accidents on Kansas Highways Using Milled Centerline Rumble Strips*, M.S. thesis, Kansas State University, Manhattan, 2001.
- "Centerline Rumble Strips, the Delaware Experience," Delaware Department of Transportation, Dover, Nov. 2003 [Online]. Available: [www.deldot.net/static/projects/rumblestripindex.html](http://www.deldot.net/static/projects/rumblestripindex.html).
- Cook Research and Consulting, Inc., "Focus Groups on Drivers' Reactions to Centerline Rumble Strips on TH 23 (Willmar to St. Cloud)," Unpublished Report for Minnesota DOT, Project M-401, June 2001.
- Davis, V., "Is Rumble a Deterrent," Department of Economics, University of Colorado at Denver, Dec. 2002, unpublished.
- Fitzpatrick, K., K. Balke, D.W. Harwood, and I.B. Anderson, *NCHRP Report 440: Accident Mitigation Guide for Congested Rural Two-Lane Highways*, Transportation Research Board, National Research Council, Washington, D.C., 2000, 178 pp.
- Griffith, M.S., "Safety Evaluation of Rolled-in Continuous Shoulder Rumble Strips Installed on Freeways," *Transportation Research Record 1665*, Transportation Research Board, National Research Council, Washington, D.C., 1999, pp. 28–35.
- Griffith, M.S., "Safety Evaluation of Rolled-in Continuous Shoulder Rumble Strips Installed on Freeways," *ITE Journal*, Vol. 70, No. 6, 2000, pp. 37–45.
- Gupta, J., *Development of Criteria for Design, Placement, and Spacing of Rumble Strips*, Final Report FHWA/OH-93/022, Ohio Department of Transportation, Columbus, 1994.
- Hanley, K.E., A.R. Gibby, and T.C. Ferrara, "Analysis of Accident-Reduction Factors on California State Highways," *Transportation Research Record 1717*, Transportation Research Board, National Research Council, Washington, D.C., 2000, pp. 37–45.
- Harwood, D.W., *NCHRP Synthesis of Highway Practice 191: Use of Rumble Strips to Enhance Safety*, Transportation Research Board, National Research Council, Washington, D.C., 1993, 74 pp.
- Harwood, D.W., "Enhancing Highway Safety with Rumble Strips," *TR News*, No. 178, 1995, pp. 12–16.
- "Help Stop Rumble Strips in Deer Creek and Golden Gate Canyons," Bicycle Colorado, Denver [Online]. Available: <http://bicyclecolo.org/site/page.cfm?pageID=281> [Dec. 6, 2002].
- Johnson, K., "How to Prevent Run-Off-the-Road Crashes," *Traffic Safety*, 00(3), 2000, pp. 17–19.
- Mahoney, K.M., R.J. Porter, E.T. Donnel, D. Lee, and M.T. Pietrucha, *Evaluation of Centerline Rumble Strips on Lateral Vehicle Placement and Speed on Two-Lane Highways*, Final Report, Pennsylvania Transportation Institute, University Park, Mar. 2003.
- Monsere, C.M., "Preliminary Evaluation of the Safety Effectiveness of Centerline (Median) Rumble Strips in Oregon," Presented at the ITE Quad Conference, Seattle, Wash., Apr. 9, 2002.
- Morena, D.A., "Rumbling Toward Safety," *Public Roads*, Vol. 67, No. 2, Sep./Oct. 2003, pp. 28–33.
- Neuman, T.R., et al., *NCHRP Report 500: Guidance for Implementation of the AASHTO Strategic Highway Safety Plan, Vol. 4: A Guide for Addressing Head-On Collisions*, Transportation Research Board, National Research Council, Washington, D.C., 2003, 82 pp.
- Noyce, D.A. and V.V. Elango, *Safety Evaluation of Centerline Rumble Strips*, Final Report, University of Massachusetts Transportation Center, Amherst, 2003.
- "ODOT Installs Safety Rumble Strips on Central Oregon Highways," Oregon Department of Transportation, Salem, Aug. 27, 2003 [Online]. Available: [www.odot.state.or.us/region4/redesign/news\\_archives/rumble%20stripes%20on%20Central%20Oregon%20Highway.htm](http://www.odot.state.or.us/region4/redesign/news_archives/rumble%20stripes%20on%20Central%20Oregon%20Highway.htm).
- Outcalt, W., *Centerline Rumble Strips*, Report No. CDOT-DTD-R-2001-8, Interim Report, Colorado Department of Transportation, Denver, Aug. 2001.
- Perrillo, K., *The Effectiveness and Use of Continuous Shoulder Rumble Strips*, 1998 [Online]. Available: <http://www.ohs.fhwa.dot.gov/rumblestrips/resources/rumblekp.htm>.
- Persaud, B.N., *NCHRP Synthesis of Highway Practice 295: Statistical Methods in Highway Safety Analysis*, Transportation Research Board, National Research Council, Washington, D.C., 2001, 75 pp.
- Persaud, B., R. Retting, and C. Lyon, *Crash Reducing Following Installation of Centerline Rumble Strips on Rural Two-Lane Roads*, Insurance Institute for Highway Safety, Arlington, Va., 2003.
- Russell, E.R., R. Stokes, and M.J. Rys, *Centerline Rumble Strips on Two-Lane Rural Highways—Interim Report*, Kansas State University, K-TRAN Project No. KSU (00)-1, Manhattan, 2000.
- Rys, M.J., E.R. Russell, and T.S. Brin, "Evaluation of Milled Centerline Rumble Strip Patterns," *Journal of Transportation Forum*, Vol. 57, No. 4, 2003, pp. 135–147.
- Suzman, J., "Rumble Strips: A Wake-Up Call for Drowsy Drivers," *IMSA Journal*, Vol. 37, No. 6, 1999, 36 pp.
- Synthesis of Best Practices for the Implementation of Shoulder and Centerline Rumble Strips*, Synthesis of Practice 8, Transportation Association of Canada, Ottawa, ON, Canada, 2000.

## BIBLIOGRAPHY

- Bacchus, A. and A.M. Khan, "Economic Feasibility and Related Issues of Highway Shoulder Rumble Strips," *Transportation Research Record 1498*, Transportation Research Board, National Research Council, Washington, D.C., 1995, pp. 92–101.
- "Bicyclists and Things That Go Bump on the Road," 1999 [Online]. Available: <http://www.ohs.fhwa.dot.gov/rumblestrips/issues/bikeissues.html>.
- Cheng, E.Y., M.O. Christensen, and E. Gonzalez, *Application and Evaluation of Rumble Strips on Highways*, Compendium of Technical Papers, 64th Institute of Transportation Engineers Annual Meeting, Jan. 1994, pp. 499–503.
- El-Gindy, M., et al., *Bicycle-Friendly Shoulder Rumble Strips*, Final Report PTI 2K15, Pennsylvania Department of Transportation, Scranton, 2000.
- Garder, P., "Rumble Strips or Not Along Wide Shoulders Designated for Bicycle Traffic?" *Transportation Research Record 1502*, Transportation Research Board, National Research Council, Washington, D.C., 1995, pp. 1–7.
- Hall, J.W., *Innovative Treatments for Run-Off-the-Road Accidents*, Final Report CE-03(91), FHWA-HPR-NM-89-02, FHWA/NMSHTD-91-02, New Mexico State Highway and Transportation Department, Santa Fe, 1991 44 pp.
- Hassan, D., *Demonstration of Milled Rumble Strips on Asphalt Shoulders in the State of Kansas*, Federal Highway Administration, Kansas Division, 1999.
- Hickey, J.J., Jr., "Shoulder Rumble Strip Effectiveness: Drift-Off-Road Accident Reductions on the Pennsylvania Turnpike," *Transportation Research Record 1573*, Transportation Research Board, National Research Council, Washington, D.C., 1997, pp. 105–109.
- Hudson, R., "Ride the Rumble Strips" [Online]. Available: <http://www.verinet.com/~pedal/editor.htm> [1999, Nov. 17].
- Moeur, R.C., "Analysis of Gap Patterns in Longitudinal Rumble Strips to Accommodate Bicycle Travel," *Transportation Research Record 1705*, Transportation Research Board, National Research Council, Washington, D.C., 2000, pp. 93–98.
- Pilutti, T. and A.G. Ulsoy, *Decision Making for Road Departure Warning Systems*, American Control Conference (17th) Proceedings, 1998, pp. 1838–1842.
- Rural and Urban Crashes—A Comparative Analysis*, Research Note, Report HS-042 422, 1996.

# APPENDIX A

## Survey Questionnaire

**TRANSPORTATION RESEARCH BOARD (TRB)  
NATIONAL COOPERATIVE HIGHWAY RESEARCH PROGRAM  
Project 20-5, Topic 34-01  
Centerline Rumble Strip Practices  
Questionnaire**

Name of respondent: \_\_\_\_\_

Agency: \_\_\_\_\_

Title: \_\_\_\_\_

Address: \_\_\_\_\_

Telephone no: \_\_\_\_\_ Best time to call: \_\_\_\_\_

Fax: \_\_\_\_\_

E-mail address: \_\_\_\_\_

### Overview and Instructions

The information collected will be used to develop a National Cooperative Highway Research Program (NCHRP) synthesis report on "Centerline Rumble Strip Practices." If you or your agency have used, studied, considered, or have an opinion on centerline rumble strips, please review and respond to this survey.

The main purpose of this survey is to enhance the state of the practice on when and where to install centerline rumble strips; current design practices, including configuration, dimensions, traffic control devices, and pavement markings, and to assess the effects of their use.

Centerline rumble strips function like shoulder rumble strips, but their primary intent is to warn drivers whose vehicles are crossing the centerline and thus avoid potential crashes with opposing traffic. They appear to have the potential for reducing head-on crashes on two-lane roads. The synthesis should assist all states in their proper use and possibly reduce two-lane road crashes and save lives.

This questionnaire should be completed by that person(s) with knowledge of your organization's activities related to centerline rumble strips. Please answer as many of the following questions as possible. Attach additional sheets if necessary. Send copies of any related material and your completed questionnaire as soon as possible or by April 20, 2003 to:

Dr. Margaret Rys  
Industrial & Manufacturing Systems Engineering  
237 Durland Hall, KSU  
Manhattan, KS 66506

If you have any questions, do not hesitate to contact Gene Russell, telephone (785) 532-1588 or e-mail: geno@ksu.edu, or Margaret Rys, telephone (785) 532-3733 or e-mail: malrys@ksu.edu

**WE APPRECIATE YOUR RESPONSE—THANK YOU**

Survey Questionnaire

1. Are there any centerline rumble strips on your highways? Yes \_\_\_ No \_\_\_ (If "no," please go to Question 7.)

2. Design Issues

a. Type of construction:

Milled \_\_\_\_\_ Rolled \_\_\_\_\_ Ground \_\_\_\_\_ Raised \_\_\_\_\_

Combination(s) \_\_\_\_\_

b. Dimensions: (Please provide sketch/drawing if available.)

Length \_\_\_\_\_ Width \_\_\_\_\_ Depth \_\_\_\_\_ Edge to Edge Spacing \_\_\_\_\_

c. How many miles by type/dimensions? \_\_\_\_\_

d. Relation to roadway:

• Continuous or on specific sections; e.g., curves, no passing zones. \_\_\_\_\_

• Where are the rumble strips in relation to the longitudinal joint and centerline? \_\_\_\_\_

• Did you have to adjust lane width because of the rumble strips? \_\_\_\_\_

e. What type of material do you use for centerline markings? \_\_\_\_\_

f. Do centerline rumble strips reduce nighttime retroreflectivity of the material? \_\_\_\_\_

g. Other comments relative to design (use back if needed and check here \_\_\_\_\_):

3. Operational Effects (cars, trucks)

a. Do you have any evidence or opinion of driver reactions to rumble strips on their left; e.g., some people fear it results in drivers jerking the wheel to the left?

Yes \_\_\_ No \_\_\_

Evidence or opinion \_\_\_\_\_

b. Does the reduced drivable area or drivers crossing the centerline create any passing or operational problems?

Yes \_\_\_ No \_\_\_

Problem, if yes \_\_\_\_\_

c. Are there problems with water accumulating in the rumble strips, either for drivers or for pavement deterioration?

Yes \_\_\_ No \_\_\_

Explain, if yes \_\_\_\_\_

d. Are you aware of any complaints from residents about noise from the rumble strips?

Yes \_\_\_\_ No \_\_\_\_

Explain, if yes \_\_\_\_\_

\_\_\_\_\_

e. Any other operational effects (use back if needed and check here \_\_\_\_\_):

\_\_\_\_\_

\_\_\_\_\_

4. Operational Effects (motorcycle, bicycles)

a. What has been the response of the motorcycle community regarding the centerline rumble strips? \_\_\_\_\_

\_\_\_\_\_

b. What has been the response of the bicycle community regarding the centerline rumble strips? \_\_\_\_\_

\_\_\_\_\_

\_\_\_\_\_

5. Safety

What before and after crash data do you have on the sections where the rumble strips have been installed? (If no data, do you have any indications; e.g., observations, regarding positive or negative effects?) \_\_\_\_\_

\_\_\_\_\_

\_\_\_\_\_

6. Policy

Do you have any policy regarding roadway cross section, speed, etc., for which you would or would not install centerline rumble strips? \_\_\_\_\_

\_\_\_\_\_

\_\_\_\_\_

7. Case Studies

Do you have or know of any projects with documented information we could use for a case study? Yes \_\_\_\_ No \_\_\_\_

Person to contact for this information \_\_\_\_\_

8. Studies

Have you ever studied or considered using centerline rumble strips in your state? Yes \_\_\_\_ No \_\_\_\_

Explain your viewpoint or opinion on them.

\_\_\_\_\_

\_\_\_\_\_

**We would appreciate receiving any warrants, guidelines, research results, or opinions that you may have on the use of centerline rumble strips. You may contact us: Gene Russell, Phone (785) 532-1588, e-mail geno@ksu.edu, or Margaret Rys, Phone (785) 532-3733, e-mail malrys@ksu.edu.**

## APPENDIX B

### List of Respondents

State/Province	Agency	Title
Alabama	Alabama DOT	State Traffic Engineer
Alaska	Alaska Department of Transportation & Public Facilities	Research Engineer
Arizona	Arizona Department of Transportation, Traffic Group	Standards Engineer, NPZ Manager
Arkansas	Arkansas State Highway and Transportation Department	
California	California Department of Transportation	Senior Transportation Engineer
Colorado	Colorado Dept. of Transportation	Eng Tech II
Connecticut	Connecticut DOT, Division of Research	Transportation Engineer III
Delaware	Delaware Department of Transportation	HSIP Manager
Florida	Research Center	Director
Georgia	Georgia DOT	State Materials and Research Engineer
Hawaii	Hawaii Department of Transportation, Highways Division, Traffic Branch	Traffic Design Services Project Manager
Idaho	Idaho Transportation Department	Traffic Engineer
Illinois	Illinois Department of Transportation–Bureau of Materials and Physical Research	Research Coordination Engineer
Indiana	Indiana Department of Transportation	Construction Field Engineer
Iowa	Iowa Department of Transportation	Director, Office of Traffic and Safety
Kansas	Dept. of CE, KSU	Professor
Kentucky	Kentucky Transportation Cabinet	Transportation Engineer Branch Manager
Louisiana	Louisiana Department of Transportation and Development	Traffic Engineering Administrator
Maine	Maine DOT	Transportation Research Engineer
Maryland	Maryland State Highway Administration	Director, Office of Traffic and Safety
Massachusetts	Mass. Highway Department	Assistant District Construction Engineer
Michigan	Michigan Department of Transportation (MDOT)	Pavement Marking Engineer
Minnesota	Minnesota DOT	Assistant Traffic Safety Engineer
Mississippi	Mississippi DOT	State Research Engineer
Missouri	Missouri Department of Transportation	Technical Support Engineer
Montana	Montana Department of Transportation	Chief Traffic and Safety Bureau
Nebraska	Nebraska Department of Roads	Research Engineer
Nevada	Nevada Department of Transportation–Research Division	
New Jersey	New Jersey DOT	Research Manager
New York	Transportation R&D Bureau–New York State Department of Transportation	Acting Director
North Dakota	North Dakota Department of Transportation	Administration Transportation Engineer I
Ohio	Office of Roadway Engineering, Ohio Dept. of Transportation	Standards Engineer
Oklahoma		
Oregon	Oregon Department of Transportation	Research Engineer
Pennsylvania	Pennsylvania Department of Transportation Bureau of Highway Safety and Traffic Engineering	Manager, Highway Safety Engineering Section



<b>State/Province</b>	<b>Agency</b>	<b>Title</b>
Rhode Island	RI Department of Transportation	Managing Engineer
South Carolina	South Carolina DOT	State Traffic Operations Engineer
South Dakota	South Dakota Department of Transportation	Research Program Manager
Tennessee	Tennessee DOT, Materials and Test Division	
Texas	Texas Department of Transportation– Research and Technology Implementation Office	Research Engineer
Utah	Utah Department of Transportation	Operations Engineer
Virginia	Virginia DOT	Research Scientist
Washington	Washington State DOT	State Traffic Design Engineer
West Virginia	West Virginia Division of Highways	Special Projects and Programs Engineer–Traffic Engineering Division
Wisconsin	Wisconsin Department of Transportation	Chief Roadway Development Engineer
Wyoming	Wyoming Department of Transportation	Systems Planning Supervisor and Bike/Ped Coordinator
Alberta	Alberta Transportation	Geometric Standards Specialist
Manitoba	Manitoba Transportation	Director, Traffic Engineering
New Brunswick	New Brunswick Department of Transportation	Assistant Director of Maintenance and Traffic
Newfoundland and Labrador	Dept. of Works, Services & Transportation, Govt. of Newfoundland and Labrador	Manager of Highway Design & Traffic Engineering (A)
Nova Scotia	Nova Scotia Department of Transportation and Public Works	Acting Manager Traffic Engineering
Quebec	Ministère des Transports du Québec (Quebec DOT)	
Saskatchewan	Saskatchewan Highways and Transportation	Operations Standards Engineer

## APPENDIX C

### State Policies, Guidelines, and Related Documents

#### Policy for Centerline Rumble Strips—California

##### Program Procedure and Guidelines for 2–3 Lane Highway Cross-Centerline Accident Monitoring

A program element was created and attached to the Highway Safety Improvement Program (HB1) in a joint memorandum from Jim Borden and Jim Nicholas on October 8, 1996. This program was initiated out of a study done by a committee of Caltrans engineers. Its purpose is to reduce fatal cross-centerline accidents on two and three lane facilities. Using this program, Caltrans intends to initiate improvements to reduce the number and the severity of accidents. The procedures to accomplish this program are discussed below.

- A) Each year a statewide TASAS Selective Accident Retrieval (TSAR) report will be requested with the following criteria:
  - 1) The access control is conventional or expressway,
  - 2) A minimum of one vehicle from each opposing direction involved in a collision,
  - 3) Severity is fatal,
  - 4) Five calendar years of data, and
  - 6) Left-turn and U-turn accidents are excluded.
- B) The resultant TSAR data file will be evaluated for accident concentration locations. A roadway segment will be considered to have a concentration if there are three or more cross-centerline fatal accidents and a cross-centerline *fatal* accident rate of 0.12 or greater fatal acc/mi/yr. Identified locations will be tabulated and highlighted to indicate a cross-centerline fatal accident concentration or remain blank. The action that the district performs for each of these identified locations is explained below in sections (E) through (H).
- C) The following point system is then applied to each cross centerline fatal accident concentration:

Number of Fatal Accidents	Value
Less Than 4	5
4–5	10
6–8	20
9–11	28
12+	35

Number of Deaths	Value
Less than 4	2
4–5	5
6–8	10
9–12	15
13–14	20
15+	25

Fatal Accident Rate (fatal acc/mi/yr)	Value
Less than 0.15	2
0.15–0.249	5
0.25–0.749	10
0.75+	15

Death Rate (deaths/mile/year)	Value
Less than 0.25	2
0.25–0.499	5
0.50–0.999	10
1.00+	15

Total Accidents/Mile	Value
Less than 10	2
10–19.99	4
20–29.99	6
30–49.99	8
50+	10

- D) Each location will then receive a total weighted value by summing up the values in the five categories (Section C).
- E) Each location in which a fatal cross-centerline accident occurred in the year of 1998 (marked by a \* on both lists) and received a total weighted value of 40 or more will prompt a Headquarters (HQ) request for an investigation study of the site. These locations are marked with a symbol (□□) on the Cross Centerline Accident List and the Summary and Weighted Value List shows a “**REPORT**” required for the given concentration location. Following this study, the investigating district sends a

memorandum outlining its observations, recommendations, and proposals to the HQ Highway Safety Improvement Program. Please consider the history of this location in your study as it pertains to this monitoring program as well (i.e., if the location has seen an increase/decrease in cross-centerline collisions etc.).

F) Those locations with a weighted value less than 40 and a fatal cross-centerline accident occurring in the year of 1998 will be marked with a box (□) on the Cross Centerline Accident List and the Summary and Weighted Value List will have a “**REVIEW SITE**.” These locations will be for the District’s information and no report to Headquarters is necessary. However, the District may pursue the development of a **Minor B** safety improvement project for these locations. Districts are encouraged to implement incremental improvements through low-cost roadway betterment that may reduce cross-centerline accidents.

G) Those locations without a “**REPORT**” or “**REVIEW SITE**” are locations that had previous concentrations, but the location did not experience a cross-centerline fatal accident in the year of 1998. These locations are maintained as monitored locations and do not require a study done by the districts.

H) Low-cost improvements should be tried first. They include barrier striping, restriping with raised profile thermoplastic traffic stripe, rumble strips on the outside paved shoulder, centerline buffer zones, rumble strips on a centerline buffer zone, surface mounted channelizers on a centerline buffer zone, black raised pavement markers on the centerline, and other innovative devices and applications.

## Policy for Centerline Rumble Strips—Utah

Centerline rumble strips may be installed on state highways meeting the following criteria:

1. On highways with experience of high cross-over head-on accidents or high potential for head-on accidents,
2. On highways where the posted speed limit is 50 mph or greater, and
3. In the following typical undivided highway applications:
  - (a) Two-way with no passing zones,
  - (b) Two-way with passing permissive in one direction,
  - (c) Two-way with passing permissive in both directions, and
  - (d) Two-way with painted median.

## Policy for Centerline Rumble Strips—Oregon

### Centerline Rumble Strips (CLRS)

Head-on crashes that didn't occur at intersections account for almost 20% of fatal crashes of each year on Oregon highways. The purpose of centerline rumble strips is to keep vehicles in their lane and prevent head-on and sideswipe meeting crashes where a median barrier was not feasible. ODOT has installed CLRS on rural highways in both a 4–16 foot (1.2–4.9 m) striped median. ODOT has also experimented with placing rumble strips on centerline pavement markings in both passing and no-passing zones when a median cannot be added. While a median is desirable because of the separation of opposing traffic it is not always feasible.

The effectiveness of SRS in reducing road departure crashes led many states to apply the same principle between opposing travel lanes. Experience by other states indicates that CLRS are effective at reducing head-on and sideswipe meeting crashes. The primary concern with the installation is the effect on a driver making a legal passing maneuver or attempting to pass in the area where the rumble strips are installed. ODOT's initial experimental application was only in no-passing zones. In the summer of 2003, CLRS were placed in a passing zone with a modified standard SRS spacing in an attempt to limit the impact to driver's legally crossing the centerline in passing areas. In altering the traditional continuous shoulder rumble strip design, it is important to monitor that there will still be enough noise and vibration to alert the driver.

Centerline rumble strips will not eliminate all cross-over crashes, especially those caused by excessive speed, loss of control, and most weather-related crashes. Because they are intended to alert drivers "drifting" over the center, rumble strips should be used where crash data indicate that type of driver error is prevalent. In addition to CLRS, some head-on crashes may be mitigated by improvements to the shoulder, since many head-on crashes are a result of a driver overcorrecting after their vehicle has departed the roadway to the right.

The use of either CLRS is still considered experimental. ODOT will monitor our existing installations with a before-and-after crash study as well as national studies on the topic to better understand their effectiveness. To be approved for experimental installation, Region Traffic must submit an investigation to the State Traffic Engineer that documents a safety problem correctable with the use of milled-in centerline rumble strips. All guidelines below must be met, or a justification for deviation included.

#### Guidelines for CLRS Installation on Rural Highways with Medians—Type D

- 1) State Traffic Engineer's approval is required for installation.

- 2) Crash history indicates a large number of head-on or sideswipe meeting crashes that would be treatable with CLRS.
- 3) Milled-in centerline rumble strips (CLRS) can be used on new or existing bituminous pavement. To retrofit CLRS on existing pavement, the pavement should be in sufficiently good condition to effectively accept the milling process without raveling or deteriorating. Otherwise the pavement should be upgraded prior to milling any desired CLRS.
- 4) The design and installation of the centerline rumble strip is shown in drawing "Type D" in Appendix H. Specifications may be adapted from Section 00865 of the Oregon 2002 Standard Specifications. There is no standard detail or drawing for this installation as yet.
- 5) A minimum median width of 4 feet (1.2 m) is needed for this rumble strip installation. For medians 4 feet (1.2 m) in width, place the rumble strips in the center of the median. For medians greater than 4 feet (1.2 m) in width, place the rumble strips 12 in. (300 mm) inside of each median stripe.
- 6) Do not install CLRS on
  - a) Bridge decks;
  - b) In the area of intersections with public roads. Stop CLRS 650 feet (200 m) in advance of intersections or 330 feet (100 m) in advance of left turn taper if one exists;
  - c) CLRS should not be placed in areas with short distances between access points.
- 7) For maintenance reasons, consider the use of durable striping in conjunction with milled-in rumble strips. Some of the equipment that ODOT owns for painting has difficulty in areas where the milled-in rumble strips exist because the wheel track of the sprayer hits the rumble strips. Please contact the Region Traffic Manager or Striping Supervisor to verify the striping equipment available.
- 8) No deletion shall be considered unless there is a clear and documented problem. Inform the Region Traffic Manager and State Traffic Engineer of decisions to delete existing rumble strip installations.

#### Guidelines for CLRS Installation on Rural Highways Without Medians—Type E

- 1) State Traffic Engineer's approval is required for installation.
- 2) Crash history indicates a large number of head-on or sideswipe meeting crashes that would be treatable with CLRS.
- 3) If installed in a passing section, consider the noise impacts to residential areas nearby.

- 4) Milled-in centerline rumble strips (CLRS) can be used on new or existing bituminous pavement. To retrofit CLRS on existing pavement, the pavement should be in sufficiently good condition to effectively accept the milling process without raveling or deteriorating. Otherwise the pavement should be upgraded prior to milling any desired CLRS.
- 5) The design and installation of the shoulder rumble strip is shown in drawing "Type E" in Appendix H. For installation in areas where passing is allowed, a spacing of 2 ft–4 ft–2 ft on center shall be used. In no passing sections, a continuous 2 ft spacing will be used. Specifications may be adapted from Section 00865 of Oregon's 2002 Standard Specifications. There is no standard detail or drawing for this installation as yet.
- 6) Do not install CLRS on
  - a) Bridge decks;
  - b) In the area of intersections with public roads. Stop CLRS 650 feet (200 m) in advance of intersections or 330 feet (100 m) in advance of left turn taper if one exists;
  - c) CLRS should not be placed in areas with short distances between access points.
- 7) For maintenance reasons, consider the use of durable striping in conjunction with milled-in rumble strips. Some of the equipment that ODOT owns for painting has difficulty in areas where the milled-in rumble strips exist because the wheel track of the sprayer hits the rumble strips. Please contact the Region Traffic Manager or Striping Supervisor to verify the striping equipment available.
- 8) No deletion shall be considered unless there is a clear and documented problem. Inform the Region Traffic Manager and State Traffic Engineer of decisions to delete existing rumble strip installations.

## Guidelines for Centerline Rumble Strips—Pennsylvania

### Attachment A

#### MILLED CENTERLINE RUMBLE STRIPS (For Non-Interstate and Non-Expressways Use)

##### Responsibilities:

District Safety Engineer is the process Owner.

##### Guidelines for Use:

1. The purpose of milled center line rumble strips (CLRS) is to reduce the occurrence of head-on and/or sideswipe crashes on undivided two-lane or four-lane highways.
2. Consider CLRS on the following locations and under following conditions:

Roadway Description	Typical Drawing Detail
Roadway with 12 feet or greater lane width and minimum of 3 feet of paved shoulder.	Detail # 1
Roadway with 11 feet lane width and minimum of 3 feet of paved shoulder.	Detail # 1 or Detail # 2
Roadway with 11 feet lane width and less than 3 feet of shoulder or no shoulder.	Detail # 2
Roadway with 10 feet lane width with or without shoulder.	Detail # 2
Roadway with less than 10 feet lane width.	Consult BHSTE

3. Milled centerline rumble strips (CLRS) are for use on bituminous pavement.
4. Installing CLRS on bituminous pavement requires an ID-2 or ID-3 surface with BCBC base or better.

5. If it is desired to retrofit CLRS on existing pavement, the pavement should be in sufficiently good condition, as determined by the District, to effectively accept the milling process without raveling or deteriorating. Otherwise the pavement needs to be upgraded prior to milling any desired CLRS.
6. CLRS should not be installed on existing concrete pavements with overlay less than 2½ in. in depth.
7. Do not install CLRS on bridge decks.
8. CLRS may be installed in passing zones where deemed appropriate by District safety personnel. Consider reducing depth of cut to ¾ in. in areas where passing is permitted. If CLRS are being discontinued for a passing zone, use engineering judgment as to where to terminate CLRS in advance of a passing zone.
9. CLRS are to be broken for intersections. Also consider breaking for driveways according to engineering judgment. When breaking CLRS pattern, discontinue CLRS 25 feet from the Point of Curvature of any such highway or driveway (refer to Typical Detail #3).
10. Coordinate the milling of CLRS with all necessary project phases. Do not mill the CLRS until all appropriate construction phases are completed.
11. Coordinate the milling of CLRS with traffic line painting operations (a) to avoid milling newly applied traffic lines and (b) to install new yellow centerlines within two weeks of CLRS completion.
12. Consult the Bureau of Highway Safety & Traffic Engineering before installing CLRS on highways with travel lane widths that are less than 10 feet.
13. Take into consideration potential noise impacts when contemplating the installation of CLRS in residential or urban areas.

#### DESIGN DEVIATION

Deviation from the above specifications and guidelines may be considered by the district; however, they must be approved by the Bureau of Highway Safety & Traffic Engineering prior to being implemented.

**Attachment A (cont.)  
Milled Centerline Rumble Strips  
Typical Drawing Detail # 1**

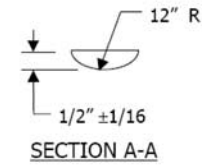
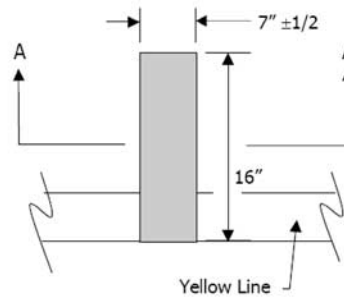
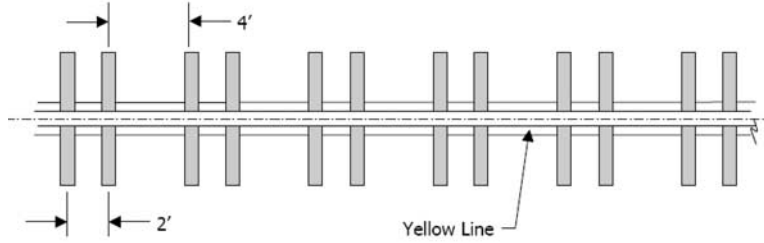

**Typical Drawing Detail # 2**

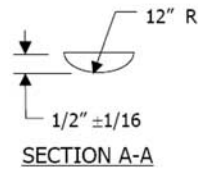
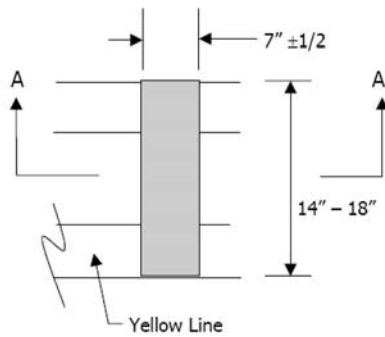
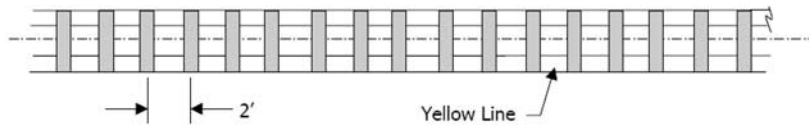



**Attachment A (cont.)**  
**Milled Centerline Rumble Strips**  
**Typical Drawing Detail # 3**

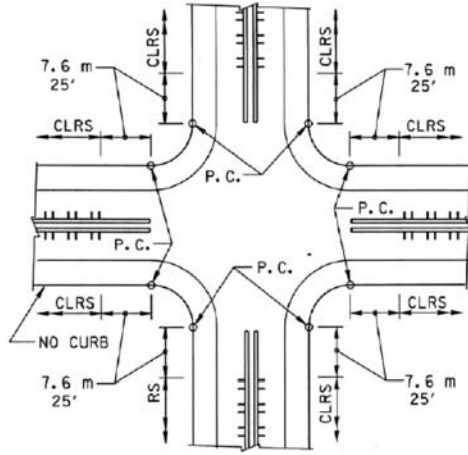

TYPICAL INTERSECTION DETAIL

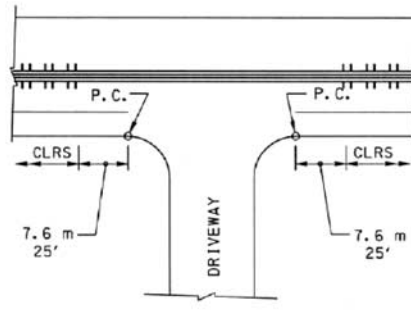

TYPICAL DRIVEWAY DETAIL

## Guidelines for Centerline Rumble Strips—Minnesota

**Note that this Draft Guideline has not been adopted by Mn/DOT. This draft Guideline has been posted on-line for information purposes only. <http://www.dot.state.mn.us/trafficeng/safety/rumble/index.html>.**

### DRAFT Centerline Rumble Strip (CLRS) Guideline—July 2002

Based upon research conducted by the Office of Traffic, Security, and Operations (OTSO), it is estimated that an effective crash reduction factor for head-on and crossing centerline crashes of up to 40% could be achieved with the installation of CLRS. It is recommended that districts consider installation of CLRS on new rural 2-lane and 4-lane undivided projects where sufficient crash history dictates. Existing concrete pavements must have 2.5 in. or greater overlays in order to be eligible under this guideline. Guidelines below detail specific locations that are eligible for CLRS installation under this guideline.

#### Guidelines for Use

1. The purpose of milled CLRS is to reduce the occurrence of head-on and/or across the centerline side-swipe crashes on undivided 2-lane or 4-lane highways. These types of crashes are often severe and are referred to as “correctable” by CLRS in this guideline.
2. Consider CLRS on the following rural locations and under the following conditions:

Roadway Description	CLRS Installation Recommended?*
2-lane or 4-lane undivided with 12' or 11' lanes, with or without paved shoulders	YES
2-lane or 4-lane undivided with 10' or less lanes, with paved shoulders	YES—if min. 10' driving lane can be maintained by “borrowing” width from shoulder; otherwise, NO
2-lane or 4-lane undivided with 10' or less lanes, without paved shoulders	NO

\*For YES, see Details 1 and 2 for design specification.

3. Qualification for shoulder rumble strips (SRS) and CLRS are independent of each other. That is, both shoulder rumble strips and CLRS should be used if a cross section meets the criteria for both installations. If both installations are recommended but not possible based on cross-section dimensions, engineering judgment based on crash history should be used to determine whether SRS or CLRS should be installed.
4. Milled CLRS are for use on bituminous pavement or on bituminous over concrete pavements that have a minimum 2.5 in. of bituminous overlay.
5. If it is desired to retrofit CLRS on existing pavement, the pavement should be in sufficiently good condition, as determined by the district, to effectively accept the milling process without raveling or deteriorating. Otherwise the pavement needs to be upgraded prior to milling any desired CLRS.
6. CLRS should not be installed on bridge decks.
7. The posted speed limit should be at least 50 mph in order to qualify under this guideline, unless a high correctable crash history exists. In this case, CLRS may be installed under any posted speed limit with appropriate documentation.
8. CLRS should be installed in passing zones and no-passing zones alike. CLRS may be omitted in passing zones where noise pollution is an issue and there is no appreciable correctable crash history for the section in question. Engineering judgment should be used and documented in these cases.
9. CLRS are to be broken for intersections. Also, consider breaking for driveways according to engineering judgment. When breaking the CLRS pattern, discontinue CLRS 25 feet from the point of curvature of any such highway or driveway (refer to Detail #2); however, if the roadway with CLRS has left turn lanes at an intersection, the CLRS are to be broken at the beginning of the turn lane or the beginning of the taper for the turn lane.
10. Coordinate the milling of CLRS with all necessary project phases. Do not mill the CLRS until all appropriate construction phases are completed.
11. Consult OTSO before installing CLRS on highways with travel lane widths that are less than 10 feet.
12. Take into consideration potential noise impacts when contemplating the installation of CLRS in residential or urban areas.

## Report on CLRS Activities Sent by Minnesota

### DRAFT RUMBLE STRIP WHITE SHEET

On average, there have been 80 fatal head-on and sideswipe motor vehicle crashes each year on Minnesota's two-lane highways. This trend prompted Mn/DOT to aggressively look at projects and engineering techniques that would put the brakes on these crashes. Certainly, in the past three years Mn/DOT has delivered a number of highway expansion and reconstruction projects to enhance safety. While this is a step in the right direction, Mn/DOT must continue to look to low-cost safety enhancement methods to save lives.

By 2002, Mn/DOT had installed centerline rumble strips (CLRS) on approximately 80 miles of highway. These rumble strips are designed to alert drivers driving too close to the opposite travel lane or in the process of crossing into the opposing lane through noise and vibration. Preliminary results are favorable. Market research in District 3 found that drivers felt the rumble strips did improve safety by making them more aware of their location within the driving lane. Those results, coupled by positive experiences in states such as California, Colorado, Delaware, Oregon, Pennsylvania, and Washington are encouraging. A recent study released by the Insurance Institute for Highway Safety states:

Overall, motor vehicle crashes at treated sites were reduced 14%; injury crashes were reduced by an estimated 15%. Head-on and opposing-direction sideswipe crashes—the primary target of center line rumble strips—were reduced by an estimated 21%, while head-on and opposing-direction sideswipe crashes involving injuries were reduced by an estimated 25%.

As a result, Mn/DOT installed CLRS on an additional 170 miles of rural two-lane highways throughout Central Minnesota, bringing Mn/DOT's total CLRS field installations to approximately 250 miles. The project cost was about \$700 per mile.

There are several concerns and questions with this type of installation:

- Increased noise for residents adjacent to the installations.
- Unknown effect on pavement life as well as centerline stripe.
- Unknown effect on safety by snow and ice left in the in the grooves and mixed impact on maintenance equipment and costs.
- Unknown effect on motorcycles.
- No national consensus on design and installation of the rumble strips.
- What is actual effect on goal of reducing crashes? Minnesota's experience has not mirrored national experience.

Before such a treatment is used on a routine basis, the questions and concerns must be answered. These issues and more will be researched in the next three years as part of a comprehensive research effort to further refine this engineering tool to save lives by reducing crashes and injuries.

While the use of CLRS is becoming more widespread, there are currently no states that have formal warrants for the installation of CLRS, and only two states have a guideline. One of the two states with a guideline is Pennsylvania. In the two years since the adoption of the guideline, Pennsylvania has installed numerous miles of CLRS, bringing their inventory to approximately 1,500 miles. This is a significantly large sample size, and much can be learned from their experience. Mn/DOT will monitor Pennsylvania's experience and incorporate that knowledge into Minnesota's research, as described above.

Mn/DOT has a goal of reducing fatal and serious injury crashes. It is hoped that the safety benefits of the centerline rumble strips prove to far outweigh any negative impacts, and that through further refinement they become a low-cost tool to help reduce tragedies on our roadways.

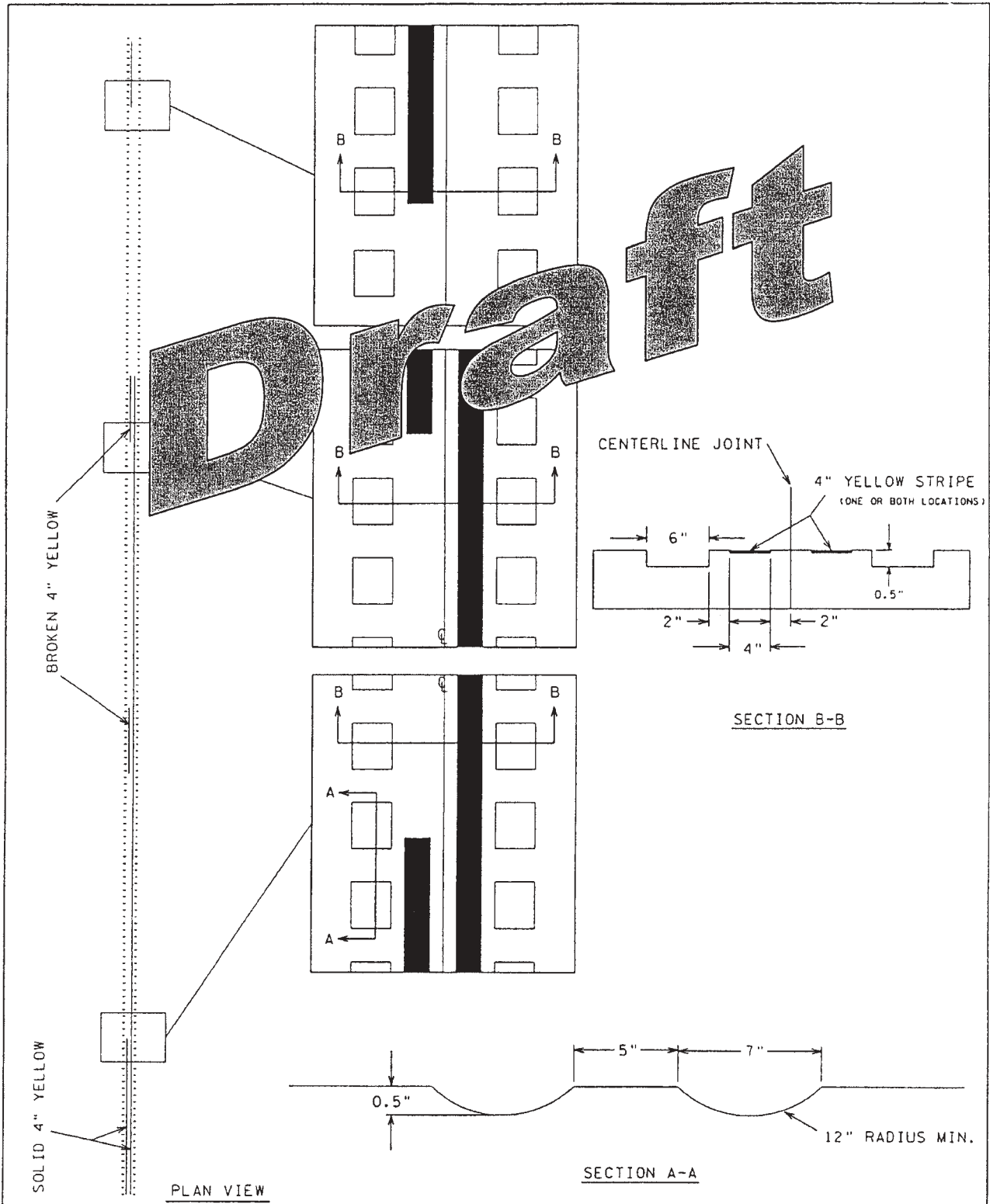

	MINNESOTA DEPT. OF TRANSPORTATION		SHEET
	DETAIL 1 MN/DOT CENTERLINE RUMBLE STRIP DESIGN STANDARD		1 OF 2

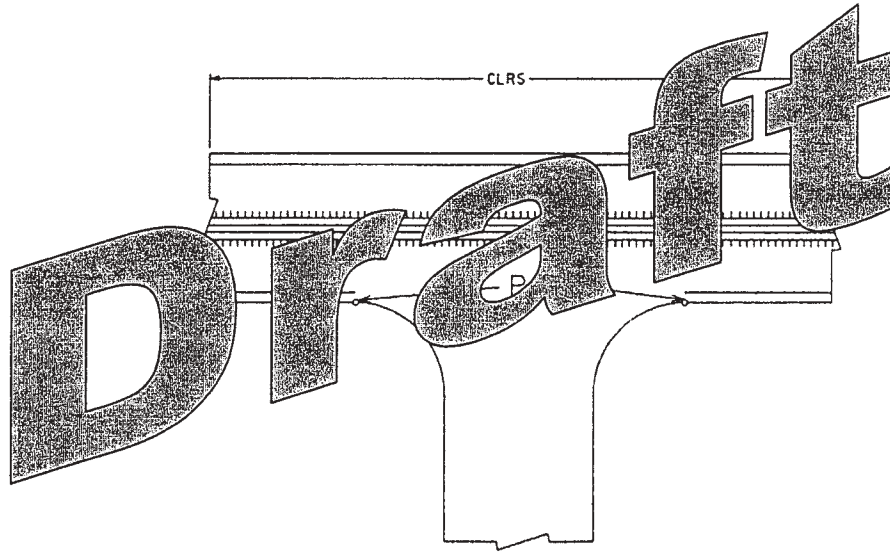

TYPICAL DRIVEWAY DETAIL

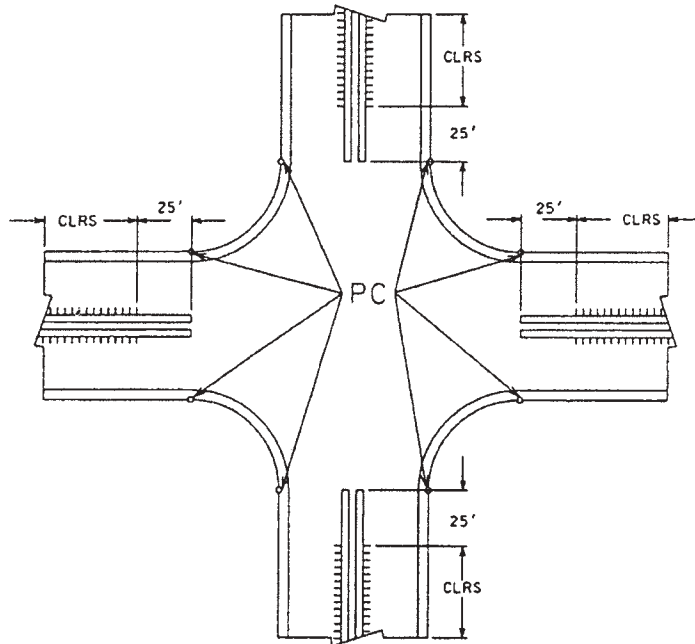

TYPICAL INTERSECTION DETAIL



MINNESOTA DEPT. OF TRANSPORTATION

DETAIL 2  
MN/DOT CENTERLINE RUMBLE STRIP  
TREATMENT AT INTERSECTIONS / DRIVEWAYS

SHEET  
2  
OF  
2

## Draft Warrants Sent by Missouri

**CENTERLINE RUMBLE STRIPS.** Centerline rumble strips (CRS) should be included on projects with new or resurfaced roadways that meet the following conditions:

- The design speed or existing posted speed limit (whichever is higher) is at least 50 mph.
- On rural two-lane roadways.
- AADT is greater than or equal to 3,500. **(PROACTIVE)**
- AADT is less than 3,500, and there is a cross-centerline crash rate of at least 10 per hundred million vehicle miles traveled. **(REACTIVE)** The cross-centerline crashes should include only those crashes that a centerline rumble strip could influence (distracted drivers, sleepy drivers, etc.). A crash that qualifies as a cross-centerline crash is any crash that begins with a vehicle encroaching on the opposing lane. It does not include crashes that begin by running off the right side of the road and over-correcting and then crossing the centerline or crashes that begin by a vehicle losing control prior to crossing the centerline (due to wet pavement, snow, ice, or roadway alignment).
- The roadway width is at least 24 ft [7.2 m]. For roadway widths less than 24 ft [7.2 m] and greater than or equal to 20 ft [6.1 m], a design exception is required. Include in the design exception submittal a thorough traffic crash analysis that reviews the cross-centerline crashes and the ran-off-road-right crashes.
- The surface is concrete or the total thickness of bituminous material is at least 3¾ in. [95 mm], including thickness of existing bituminous material.
- Centerline rumble strips are not to be placed on bridges or within the limits of an intersection with left-turn lanes. The limits of the intersection are defined by the beginning of the tapers for the left-turn lanes.

Abbreviations used without definitions in TRB publications:

AASHO	American Association of State Highway Officials
AASHTO	American Association of State Highway and Transportation Officials
APTA	American Public Transportation Association
ASCE	American Society of Civil Engineers
ASME	American Society of Mechanical Engineers
ASTM	American Society for Testing and Materials
ATA	American Trucking Associations
CTAA	Community Transportation Association of America
CTBSSP	Commercial Truck and Bus Safety Synthesis Program
DHS	Department of Homeland Security
FAA	Federal Aviation Administration
FHWA	Federal Highway Administration
FMCSA	Federal Motor Carrier Safety Administration
FRA	Federal Railroad Administration
FTA	Federal Transit Administration
IEEE	Institute of Electrical and Electronics Engineers
ITE	Institute of Transportation Engineers
NCHRP	National Cooperative Highway Research Program
NCTRP	National Cooperative Transit Research and Development Program
NHTSA	National Highway Traffic Safety Administration
NTSB	National Transportation Safety Board
SAE	Society of Automotive Engineers
TCRP	Transit Cooperative Research Program
TRB	Transportation Research Board
TSA	Transportation Security Administration
U.S.DOT	United States Department of Transportation