



Assessment of Candidate Expendable Launch Vehicles for Large Payloads (1984)

Pages
54

Size
8.5 x 10

ISBN
0309323843

Committee on NASA Scientific and Technological Program Reviews; Commission on Engineering and Technical Systems; National Research Council

 [Find Similar Titles](#)

 [More Information](#)

Visit the National Academies Press online and register for...

- ✓ Instant access to free PDF downloads of titles from the
 - NATIONAL ACADEMY OF SCIENCES
 - NATIONAL ACADEMY OF ENGINEERING
 - INSTITUTE OF MEDICINE
 - NATIONAL RESEARCH COUNCIL
- ✓ 10% off print titles
- ✓ Custom notification of new releases in your field of interest
- ✓ Special offers and discounts

Distribution, posting, or copying of this PDF is strictly prohibited without written permission of the National Academies Press. Unless otherwise indicated, all materials in this PDF are copyrighted by the National Academy of Sciences.

To request permission to reprint or otherwise distribute portions of this publication contact our Customer Service Department at 800-624-6242.

Copyright © National Academy of Sciences. All rights reserved.



1096071 PB85-111912/XAB

84-0100

Assessment of Candidate Expendable Launch Vehicles for Large Payloads

(Final rept)

National Research Council, Washington, DC.

Corp. Source Codes: 019026000

Sponsor: National Aeronautics and Space Administration, Washington, DC.

Sep 84 48p

Languages: English

NTIS Prices: PC A03/MF A01 Journal Announcement: GRAI8502

Country of Publication: United States

Contract No.: NASW-3511

In recent years the U.S. Air Force and NASA have conducted design studies of 3 expendable launch vehicle configurations that could serve as a backup to the space shuttle--the Titan 34D7/Centaur, the Atlas II/Centaur, and the shuttle-derived SRB-X--as well as studies of advanced shuttle-derived launch vehicles with much larger payload capabilities than the shuttle. The 3 candidate 'complementary' launch vehicles are judged to be roughly equivalent in cost, development time, reliability, and payload-to-orbit performance. None requires new technology nor has any significant growth potential. While the SRB-X has the advantage of common production with the shuttle, the Titan 34D7 and Atlas II have the important advantage in assuring timely access to space of launch independent of the complex shuttle environment. Advanced shuttle-derived vehicles are considered viable candidates to meet future heavy lift launch requirements; however, they do not appear likely to result in significant reduction in cost-per-pound to orbit. Efforts are required to substantially reduce this cost by development and application of advanced high energy propulsion systems, simplified design, and improved operational procedures.

Descriptors: *Launch vehicles; Spacecraft; Payloads; Comparison; Benefit cost analysis; Design; Assessments

Identifiers: Space shuttles; Expendable stages(Spacecraft); NTISNASNRC; NTISNASA

Section Headings: 22D (Space Technology--Spacecraft Launch Vehicles and Ground Support); 84E (Space Technology--Space Launch Vehicles and Support Equipment)

Assessment of Candidate Expendable Launch Vehicles for Large Payloads

Prepared by a Panel Convened by the

Committee on NASA Scientific and Technological Program Reviews

Commission on Engineering and Technical Systems

National Research Council

NATIONAL ACADEMY PRESS
Washington, D.C. September 1984

NAS-NAE

SEP 5 1984

LIBRARY

24-01-22
C.1

NOTICE: The project that is the subject of this report was approved by the Governing Board of the National Research Council, whose members are drawn from the councils of the National Academy of Sciences, the National Academy of Engineering, and the Institute of Medicine. The members of the panel responsible for the report were chosen for their special competences and with regard for appropriate balance.

This report has been reviewed by a group other than the authors according to procedures approved by a Report Review Committee consisting of members of the National Academy of Sciences, National Academy of Engineering, and the Institute of Medicine.

The National Research Council was established by the National Academy of Sciences in 1916 to associate the broad community of science and technology with the Academy's purposes of furthering knowledge and of advising the federal government. The Council operates in accordance with general policies determined by the Academy under the authority of its congressional charter of 1863, which establishes the Academy as a private, nonprofit, self-governing membership corporation. The Council has become the principal operating agency of both the National Academy of Sciences and the National Academy of Engineering in the conduct of their services to the government, the public, and the scientific and engineering communities. It is administered jointly by both Academies and the Institute of Medicine. The National Academy of Engineering and the Institute of Medicine were established in 1964 and 1970, respectively, under the charter of the National Academy of Sciences.

This study was supported by Contract NASW-3511 between the National Academy of Sciences and the National Aeronautics and Space Administration.

Copies available from:

Committee on NASA Scientific and Technological Program Reviews
National Research Council
2101 Constitution Avenue, N.W.
Washington, D.C. 20418

Printed in the United States of America

Members of the Panel

ROBERT R. FOSSUM, Dean of Engineering and Applied Science, Southern Methodist University, Dallas, Texas, Chairman
EDGAR M. CORTRIGHT, Consultant (Retired President, Lockheed California Company), Yorktown, Virginia
IVAN A. GETTING, Consultant (Retired President, The Aerospace Corporation), Los Angeles, California
RICHARD C. HENRY, Consultant (Retired Commander, Space Division, Air Force Systems Command), Long Beach, California
THOMAS W. MORGAN, Consultant (Retired Commander, Space and Missile Systems Organization, Air Force Systems Command), Jemez Springs, New Mexico
VICTOR H. REIS, Science Applications, Inc., McLean, Virginia
GORDON S. REITER, Program Manager, Space and Communications Group, Hughes Aircraft Company, Los Angeles, California
ABE SILVERSTEIN, Consultant (Retired Director, NASA Lewis Research Center), Cape Coral, Florida
H. GUYFORD STEVER, President, Universities Research Association, Inc., Washington, D.C.
THOMAS M. DONAHUE, Chairman, Space Science Board, National Research Council, Ex Officio Member

ROBERT H. KORKEGI, Study Director
JOANN CLAYTON, Professional Associate
ANNA L. FARRAR, Administrative Assistant

Preface

The Committee on NASA Scientific and Technological Program Reviews was created by the National Research Council in June 1981 as a result of a request by the Congress of the United States to the National Aeronautics and Space Administration that it establish an ongoing relationship with the National Academy of Sciences and the National Academy of Engineering for the purpose of providing an independent, objective review of the scientific and technological merits of NASA programs whenever the Congressional Committees on Appropriations so direct.¹

When a review is requested, the committee is called on to set the terms of reference, select a suitable panel of experts to carry out the task, and review the resulting report before publication.

To date 4 tasks have been undertaken: reviews of the International Solar Polar Mission,² NASA's Aeronautics Program,³ the Space Shuttle Program,⁴ and NASA's Numerical Aerodynamic Simulation Program.⁵

The fifth task, which is the subject of this report, resulted from a request by the Congressional Committees on Appropriations to the NASA Administrator in late January 1984 for an assessment of the advantages and disadvantages of various candidate expendable launch vehicles for large payloads (Appendix A).

¹Congressional Conference Report 96-1476, November 21, 1980.

²National Research Council, The International Solar Polar Mission--A Review and Assessment of Options, 1981, National Academy Press, Washington, D.C.

³National Research Council, Aeronautics Research and Technology--A Review of Proposed Reductions in the FY 1983 NASA Program, 1982, National Academy Press, Washington, D.C.

⁴National Research Council, Assessment of Constraints on Space Shuttle Launch Rates, 1983, National Academy Press, Washington, D.C.

⁵National Research Council, Review of NASA's Numerical Aerodynamic Simulation Program, 1984, National Academy Press, Washington, D.C.

The committee met on February 24, 1984, to establish terms of reference (Appendix B) for the review based on the congressional request and to nominate a panel to undertake the task. The areas of expertise sought included launch vehicle systems and space mission requirements from the point of view of DoD, NASA, industry, and the space science community, as well as national space policy and costing of launch systems.

In appointing such a group of individuals to make scientific and technical assessments, it is essential that most have a high degree of knowledge in the subject of the study. Since such individuals may appear to have a potential for bias, every effort was made to achieve a balance in backgrounds and attitudes of the panelists in order to present as objective a report as possible.

This particular task deals with but one segment of the broader issue of national space launch systems which have far reaching policy implications. The task was complicated by a military procurement action for expendable launch vehicles, initiated near the time this study was begun and still ongoing at its conclusion. Despite this, I believe that this report provides a useful input to the debate on launch systems.

The committee wishes to record its appreciation to the chairman and members of the panel and to commend them for their timely response to the charge.

Norman Hackerman
Chairman, Committee on NASA Scientific and
Technological Program Reviews

Contents

I.	INTRODUCTION.....	1
II.	APPROACH.....	3
III.	OVERVIEW OF U.S. LAUNCH OPERATIONS.....	5
	Historical Perspective, 5	
	STS Development Areas, 5	
	Industrial Base, 7	
	Cost Considerations, 10	
IV.	NEAR-TERM LAUNCH REQUIREMENTS.....	11
	Defense and Intelligence Requirements, 11	
	Need for Assured Access to Space: Peacetime, 12	
	Need for Assured Access to Space: Time of Crisis, 12	
	Commercial Requirements, 13	
	Requirements of NASA and Other Users, 13	
V.	CANDIDATE EXPENDABLE LAUNCH VEHICLES.....	15
	The Atlas II, 15	
	The Titan 34D7, 16	
	The SRB-X, 17	
	Launch Facilities, 19	
	Advantages and Disadvantages, 19	
	Cost Considerations for Candidate ELVs, 20	
VI.	FUTURE HEAVY LIFT LAUNCH VEHICLES.....	23
	Heavy Lift Vehicle Concepts, 23	
VII.	FINDINGS.....	27
	REFERENCES.....	29
	APPENDIXES	
	A. Letter dated January 25, 1984, from Edward P. Boland, U.S. House of Representatives, and Jake Garn, U.S. Senate, to James M. Beggs.....	33
	B. Statement of Task, An Assessment of Candidate Expendable Launch Vehicles for Large Payloads.....	35
	C. Committee on NASA Scientific and Technological Program Reviews.....	37
	D. Memorandum dated February 7, 1984, from Caspar Weinberger regarding Defense Space Launch Strategy.....	39
	E. Participants in Briefing Sessions.....	43

I

Introduction

National space policy establishes the Space Transportation System (STS) as the U.S. government means of access to space (Reference 1). The STS presently consists of a fleet of 3 orbiters to be supplemented by a fourth in early 1985. There is no firm commitment to further production of orbiters; however, there is in place an extensive program to build spare subsystems "thereby maintaining production readiness for a fifth orbiter" (Reference 2). Eleven orbiter flights were successfully completed during the first 3 years of operation, and launch rates of 24 per year are projected in the NASA mission plan for the late 1980s. In anticipation of a fully operational STS, government-contracted production of expendable launch vehicles (ELVs) is being phased out.

With the growing role of space systems in providing for national security, the Department of Defense (DoD) is expected to be the largest single user of the STS, accounting for at least one-third of the projected 24 flights per year. The DoD recently called for development of an expendable launch vehicle that would be complementary to the STS to provide "assured access to space" (Appendix D). For this purpose 3 candidate expendable launch vehicles, all with payload capability to geosynchronous orbit of at least 10,000 lb (comparable to that of the STS), have been under study.

At the end of March 1984, the U.S. Air Force initiated procurement action with a request for proposals (RFP) for a commercial buy of 10 complementary expendable launch vehicles to be delivered at the rate of 2 per year during the period FY 1988-FY 1992. The RFP was subsequently withdrawn and reissued on a conventional government purchase basis at the end of July 1984, and procurement action was still under way at the time the present study was completed.

In addition, with a probable future need for a payload capability substantially larger than that offered by the STS or the proposed new ELVs, both NASA and the Air Force are studying several configurations using shuttle components.

The charge to this panel stems from a request made by Senator Garn and Congressman Boland (dated January 25, 1984) to NASA Administrator James M. Beggs. The study request, as further defined

by the National Research Council's Committee on NASA Scientific and Technological Program Reviews, can be stated as a review of: (1) ELVs that could "provide a flexible back up for the space transportation system;" and (2) "advanced vehicle configurations that could increase payload to orbit at potentially reduced costs."

In regard to (1), the charge specifically calls for an assessment of:

- o large payload requirements of the DoD, NASA, and the private sector;
- o potential payload capabilities of candidate vehicles;
- o development time;
- o additional ground support requirements for various candidate systems;
- o payload compatibility between the shuttle and candidate ELVs;
- o growth potential;
- o cost trade-offs between candidate systems; and
- o total costs of maintaining a national launcher capability.

In regard to (2), the charge specifically calls for a review of:

- o future mission requirements and potential vehicle configurations.

The panel discussed a number of options and concepts for assured access to space in addition to those contained in the charge; however, the need for a timely response to the Congressional request dictated detailed examination of requirements, risks and costs only for those expendable launch vehicle concepts which had progressed to preliminary design by either industry or NASA.

II Approach

The panel met at the National Academy of Sciences in Washington, D.C., on April 12-13, June 7-8, and July 10-11, 1984. During the course of its meetings the panel was briefed by NASA personnel from Headquarters and the Marshall Space Flight Center and by Department of Defense personnel from the Pentagon, the U.S. Air Force Space Division, and the Defense Advanced Research Projects Agency. A list of briefing personnel is given in Appendix E. In addition, individual members of the panel contacted personnel from the intelligence community and industrial concerns in regard to projected space launch requirements.

The U.S. Air Force procurement action, initiated shortly after this study was commissioned, prevented the panel from obtaining technical and cost data from space launch vehicle manufacturers. Thus, the panel relied upon preliminary data furnished by NASA and the DoD. The panel was provided with extensive cost information by both these agencies and examined it in detail. In its analysis of the data the panel found in some cases marked differences between cost estimates provided by NASA and by the Air Force. Accurate cost figures for the candidate systems will not be available until contractual negotiations are completed. For these reasons, the panel concluded that no meaningful cost comparisons could be made at this time.

For the purposes of this report, the panel has defined "heavy lift" as lift capability exceeding that of the STS.

Furthermore, in the context of its charge, the panel considered only launch vehicles with payload capability equal to and exceeding that of the STS and did not address launch vehicles of lesser capability, such as those presently available in the national inventory or under commercial development.

The panel took account of other National Research Council studies such as the Assessment of Constraints on Space Shuttle Launch Rates (Reference 3), as well as reports and documents that appear in the list of references.

The panel wishes to express its appreciation to the many members of NASA and the Air Force who provided information for the study and facilitated the work of the panel.

III







Overview of U.S. Launch Operations

HISTORICAL PERSPECTIVE

At the conclusion of the successful Apollo program, a Presidential Commission recommended that the United States should continue its man-in-space program by the development of a recoverable launch vehicle, the shuttle (Reference 4). The cost of developing the shuttle was recognized as high, and the scope of the program was expanded to provide a generalized space transportation system--a means of transporting unmanned, as well as manned, payloads from the earth to space. Lift or payload requirements were established at a level to encompass all known satellite programs. The characteristics of the military satellites were well known and led to the basic performance specifications of the shuttle: bay size 15' diameter and 60' long, and lift capability to put 65,000 lb into easterly launch (low orbit). In addition, the DoD required a substantial cross-range maneuver capability to permit polar orbit injection without overflight of nations that might be unfriendly to the United States. If the shuttle met these basic specifications, it could, in principle, serve all users: military, NASA, commercial, and foreign. When NASA agreed to meet these specifications, the shuttle was declared the primary "national launch capability" (Reference 1), and the earlier expendable launch vehicles, such as the Thor-Delta, Atlas, and Titan, were to be discontinued as soon as practicable (Figures 1 and 2a and b). In short, the use of the shuttle as a launch vehicle became mandatory for DoD and all government agencies. Furthermore, the pricing policy encouraged the design of satellites compatible with the shuttle to make maximum use of the shuttle's capabilities as the primary launch vehicle.

STS DEVELOPMENT AREAS

The shuttle program represented an ambitious leap in technology that required the solution of many problems. For a developmental program of such magnitude and complexity, the shuttle's flights have been remarkably successful. However, as can be expected with all complex systems, it is still evolving. Not all of the performance

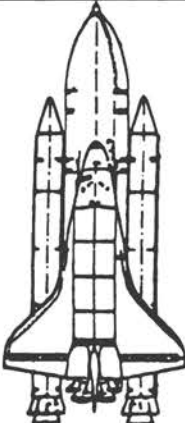
								
	SCOUT	DELTA	ATLAS-E/H*	ATLAS CENTAUR	TIIIB-AGENA	TITAN 34D/RGS	T34D/IUS/T-S	STS/IUS/CENTAUR
RESPONSIBLE AGENCY	NASA	NASA	USAF	NASA	USAF	USAF	USAF	NASA/USAF
PERFORMANCE CAPABILITY: (lb)								
SYNCH EQ	—	1450		2650	—	—	4000	5000/10,000
100 nmi POLAR	460	5500	3800/5500		7950	27,600	—	32,000
100 nmi DUE EAST	570	7800		12,300	—	—	32,900	65,000

*With apogee kick motor or stage vehicle

Courtesy of the Aerospace Corporation

Figure 1 U.S. Launch Vehicles

specifications have been met (payload capability is less than 65,000 lb, cross-range maneuver capability is limited, and there are limitations on aborting to U.S. bases). In addition, each shuttle is physically different, and not all are capable of launching from the Western Space and Missile Center. Logistic and maintenance procedures also need to be perfected.

The STS is dependent upon reusability of many of its subsystems (solid rocket booster cases, main engines, orbiter). A failure of any of these reusable subsystems may shut down operations until the problem can be identified and corrected, and a retrofit is performed across the entire fleet. In the past, problems have arisen that have shut down a major space program for as much as a year, e.g., the Apollo 4 fire. Needless to say, failures or malfunctions are not unique to reusable systems. The April 1983 Inertial Upper Stage failure is a classic example of the limitations on space launches when there is total dependence on a single system--in this case, an expendable upper stage.

Problems also arise because the STS is not yet a mature system. Many of the STS subsystems must be upgraded to meet performance specifications (e.g., sustained main engine performance at 109 percent power and reduction of the weight of the solid rocket booster cases). Systems specifications on mean time between removals are not now being met on some of the subsystems (e.g., the shuttle main engine oxidizer and fuel pumps), and a sustaining engineering program will be required to realize the full benefit of the STS concept. All of these changes are needed to achieve an acceptable level of dependability of the system.

It is to be expected that the shuttle will one day become fully operational and that projected turn-around times will be achieved if there are no major accidents or failures. But as the NASA Advisory Council's Task Force for the Study of the Effective Shuttle Utilization report dated November 17, 1983, (Reference 5) stated: "In its near singleminded pursuit of the shuttle development, NASA has moved quickly to declare the STS operational and to prepare to divest itself of expendable launch vehicles. We feel that much remains to be done before the STS becomes operational in the full sense of the word. We are concerned that the early elimination of the ELVs would leave the U.S. with neither a back-up to the shuttle nor active production lines of space launch vehicles of any kind."

INDUSTRIAL BASE

As shown in Figures 2a and 2b, under current plans, after 1986 there will be no further production of NASA or DoD launch vehicles in the U.S. Although extensive production of STS structural and component spares is underway, there are presently no firm plans for construction of a fifth orbiter to follow delivery of the fourth vehicle in early 1985. This implies the disappearance of U.S. engineering and production know-how and capability. In contrast, the

VEHICLE	CALENDAR YEARS																	TOTAL										
	60	62	64	66	68	70	72	74	76	78	80	82	84	86	88	90												
SCOUT	3	2	9	24	22	2	0	5	10	12	3	0	0	2	11	2	0	0	0	5	3	2	117					
DELTA	3	4	9	6	6	7	9	12	9	11	7	5	6	7	8	11	9	10	10	4	5	7	7	5	4	181		
ATLAS	10	12	16	12	22	25	22	14	10	0	3	7	5	7	2	6	5	2	4	4	1	0	2	3	4	3	1	202
TITAN				5	9	14	12	10	6	11	12	8	14	11	7	7	6	6	6	8	5	1	3	2	1	1	165	
SATURN		1	2	2	2	1	8	8	0	5	3	0	1	33														
STS ORBITER																			1			1	1		1	4		
	16	19	36	44	57	44	53	51	39	34	27	24	20	30	32	26	21	18	20	20	17	14	11	12	10	5	2	702

NOTES: a. Upper stages not included

b. Weapon systems vehicles not included
i.e. Atlas E, F, Thor, Titan I, II

Figure 2a U.S. Space Launch Vehicle Production

Soviet Union is not only building a space shuttle, but is also developing very heavy lift expendable launch vehicles. (Reference 6)

Once production lines are closed a restart will be far more costly and production time considerably longer. In the cases of the Atlas and Titan III, subcontractors and vendors are already being terminated in anticipation of production line shutdowns. The normal lead time for the manufacture of an expendable booster is approximately 30 months with an ongoing production base. If one has to start a launch vehicle program from "scratch" the lead time could be 7 to 10 years. For example, the Saturn V program, using some existing technology, required a development period of approximately 7 years prior to production.

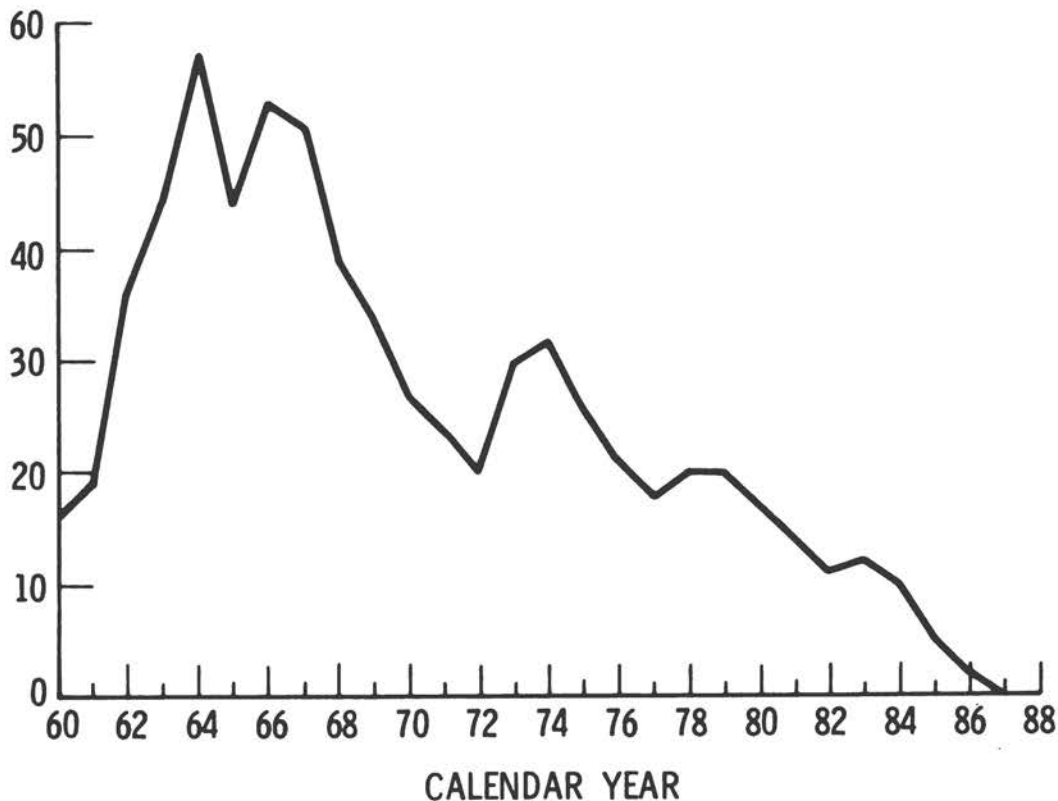

Figure 2b U.S. Space Launch Vehicle Production
 (Note: Weapon system boosters not included, i.e., Atlas E, F, Thor, Titan I, II)

COST CONSIDERATIONS

Where the payload requires the presence of man, where man himself is the object of research, or where payload recovery is required, the STS provides a unique national capability. However, space launch operations involving manned flight have been more complex and expensive than unmanned space operations. In part, the STS was planned to overcome these disadvantages by recovering the orbiter and the solid rocket casings and increasing the traffic to share in the overhead costs. Costs are also higher when a satellite is designed for use in the shuttle since each unit must be man-rated and additional design loads must be considered.* Documentation and software integration are also more complex, and cleanliness, so vital to many missions, is more difficult to maintain in a manned launch vehicle. The mixture of unclassified--including international--and classified payloads in the STS causes large increases in security costs. For the above reasons, it is not clear to the panel from the data currently available that the STS can ever be more economical than ELVs for launching unmanned DoD payloads.

According to NASA representatives, NASA establishes prices for STS launch services based on "materials and services." The charge to a customer reflects only the incremental costs associated with each launch and the share of associated operating costs. While these are the costs charged to commercial and foreign users, the DoD pays about 60 percent of this amount; starting in about 1988, DoD may be expected to pay the full amount.

France has developed an ELV, the Ariane, which is subsidized by the French government and is still in the early development phase. In general, within its range of payload capabilities, it appears today to be competitive with the STS as it is currently priced (Reference 5, p. 27). This reflects the deliberate policy of subsidization by both countries.

To be priced competitively, the STS must carry a capacity load. This means that it must find compatible satellites--that is, satellites ready for launch at the same time and into similar orbits. This requirement influences the customer's choice between the STS and ELVs, which generally carry one payload or perhaps 2 of an identical kind.

*Criteria in the NASA Office of Manned Space Flight's "Systems Safety Requirements for Manned Space Flight" far exceed requirements for expendable vehicles. In addition to considerations for crew safety, satellites must be designed to withstand the high stresses encountered in case of an abort.

IV

Near-Term Launch Requirements

There are 4 basic classes of potential users of space launch vehicles: DoD and the intelligence agencies; the commercial sector; NASA, other government agencies, and the space science and applications communities; and foreign governments. The last class is not considered below since U.S. decisions regarding launch systems will not be based on such requirements.

DEFENSE AND INTELLIGENCE REQUIREMENTS

For DoD and the various intelligence agencies, space satellites have become essential. For example, global communication, mapping and reconnaissance, global navigation, nuclear weapon monitoring, warning of missile launches, and weather monitoring are all dependent on current operational satellite systems. The Army, Navy, and Air Force have become heavily dependent on satellites in day-to-day tactical operations. Recognizing that these space systems have become necessary for U.S. security, a national policy was established that called for assured access to space (Reference 1). Stating that the STS, while a great national asset, did not provide for such assured access to space, the Secretary of Defense established a DoD Space Policy calling for a complementary launch system to the STS (Appendix D). He said a "high confidence of access to space" is "needed for all levels of conflict to meet the requirements of national security missions." He continued, "While DoD policy requires assured access to space across the spectrum of conflict, the ability to satisfy this requirement is currently unachievable if the U.S. mainland is subjected to direct attack. Therefore, this launch strategy addresses an assured launch capability only through levels of conflict in which it is postulated that the U.S. homeland is not under direct attack."

On the basis of these policy statements, the Air Force initiated procurement action for an ELV complementary to the shuttle. Several current satellite programs optimized for STS launch, while compatible for launch by the STS with the upper stage Centaur, cannot be

launched by any previous ELV.* If, therefore, an ELV complementary to the STS for launch into these high orbits (synchronous at 10,000 lb, or highly elliptical at 15,000 lb--and with large dimensions) is required, it must necessarily be a growth version of a previous ELV or a new ELV, both in throw weight and payload shroud dimensions. As a result, the Air Force has established a minimum throw weight capability to synchronous orbit of 10,000 lb which, according to Air Force briefers, accommodates all the near-term missions surveyed by the panel.

Need for Assured Access to Space: Peacetime

While DoD has priority over any other user of the STS, the normal planning cycle (e.g., orbital planning, security provisions, software integration) takes approximately 6 months. Should circumstances arise demanding an immediate DoD satellite replacement, it will be difficult to reduce this time substantially.

In the past, the DoD has been able to achieve excellent security through the autonomy of a dedicated launch facility. It has proven to be much more difficult and costly to maintain adequate security using the STS. Also, it may be necessary to launch a sensitive and militarily important security satellite without the public exposure that has become the norm in NASA flight operations.

With only the STS available it may become imperative to preempt other scheduled STS users and scheduled STS launches might be lost due to DoD requirements for immediate replacement of satellites in existing systems. Obviously, this kind of action might inhibit potential STS users.

As noted in Chapter III, with a limited shuttle fleet, a generic failure in the system could shut down the nation's ability to conduct space launch operations. Problems with the unique suppliers or support contractors could cause a stoppage in launches. The impact of such occurrences would be far more significant than that caused by similar problems in the current diverse fleet of ELVs.

Need for Assured Access to Space: Time of Crisis

In a crisis, the situation would be altered. The STS would have to overfly the Soviet Union, putting the crew and vehicle at some risk, in order to put a satellite in a polar orbit required for DoD missions. An unmanned expendable launch vehicle, on the other hand, would allow the DoD to support defense space systems with no risk to man, less political risk, and no hazard to the limited STS fleet.

*Earlier launchers allowed for a payload diameter up to 10 ft and will not accommodate a 15 ft payload. Payload weight may also exceed the capability of existing ELVs.

In the past, the DoD has been able to achieve rapid response by storage of a satellite and its launch vehicle on the launch pad. This is very difficult to do using the STS. In time of crisis the comparatively long operational recycle time of the STS limits its utility in support of time-urgent military space missions.

The security advantages offered by a dedicated launch facility, as discussed under "Peacetime" above, become even more important in time of crisis.

COMMERCIAL REQUIREMENTS

Commercial use of space, presently dominated by the communications satellite industry, is driven by costs. An important contribution to costs is the reliability of launch vehicles and firmness of scheduled launch dates. Commercial satellites are built in anticipation of using existing launch vehicles and cannot be expected to generate demand for new vehicles. If new vehicles or their components are developed, commercial users will certainly consider their uses.

In development of a new ELV, dual manifesting is another important consideration to the commercial sector. As stated, the anticipated throw weight of the proposed ELVs to synchronous orbit would be at least 10,000 lb, more than is forecast in the near-term needs of the largest commercial user. To be cost competitive, a two-satellite launch adapter similar to the Ariane SYLDA (Systeme de Lancement Double "Ariane") would be required on the new ELV in order to launch 2 spacecraft at once. Incorporation of an adapter to make it compatible with STS and Ariane would have some impact on the design of the ELV. Dual manifesting of commercial satellites is presently carried out on both STS and Ariane without major inconvenience to the user and must be a major design consideration if the proposed new system is to be used by commercial enterprises.

REQUIREMENTS OF NASA AND OTHER USERS

The NASA initiatives which have led to U.S. eminence in space are well known and need not be repeated here. In the context of this study, NASA representatives, in their briefings to the panel, April 12, 1984, stated that all of their requirements could be met by the STS and, therefore, they have no need for an ELV of comparable performance. The Space Science Board of the National Research Council is undertaking a study of the major directions for space science for the period 1995-2015. The study will assume the availability of space station, STS, and ELVs and could lead to consideration of requirements for launching heavier payloads than those presently anticipated. However, at the present time, no science missions are planned that require a capability greater than the STS. Department of Commerce needs also would be met by the STS inasmuch as their requirements are included in the NASA projections.

V

Candidate Expendable Launch Vehicles

The 3 vehicle systems under consideration by the Air Force to complement the STS--the Titan 34D7/Centaur, the Atlas II, and the shuttle-derived SRB-X--all have the potential for launching 10,000 lb into geosynchronous orbit. All use a version of the Centaur G for the upper stage and all are based on proven technologies and in large part on proven hardware elements. Descriptions and performance characteristics for these systems are given in Figures 3 to 5 and Table I.

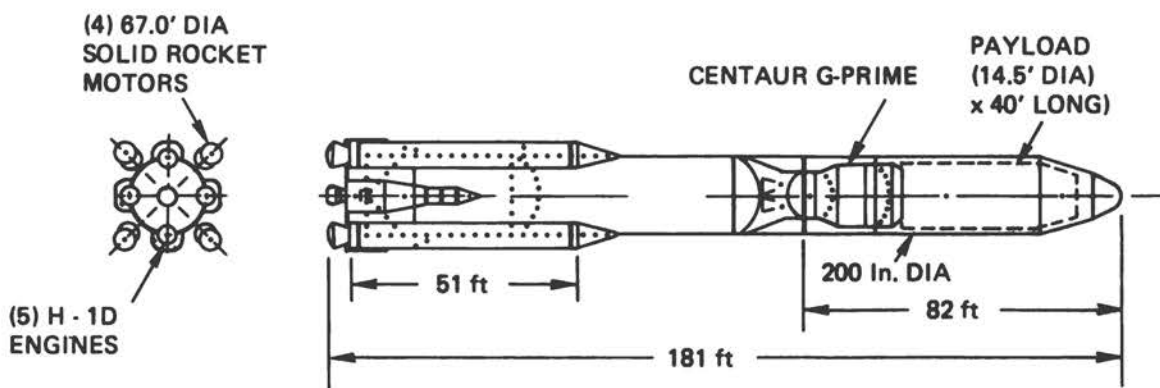

Figure courtesy USAF

Figure 3 Atlas II/Centaur

THE ATLAS II

The Atlas II/Centaur represents a redesign of the Atlas G. Its diameter is increased from 120 inches for the current Atlas to 200

inches. The Centaur G', which is being developed for the STS, will be used for the upper stage. The Atlas II propulsion system consists of 5 liquid rocket engines and 4 strap-on solid rocket motors, all of which use existing designs. The general concept for the Atlas II suggests that established technology and proven hardware will be used. The liquid rocket engines being considered for use are of proven lineage; their development was initiated over 30 years ago. Nevertheless, the Atlas II is structurally a new launch vehicle with corresponding risks.

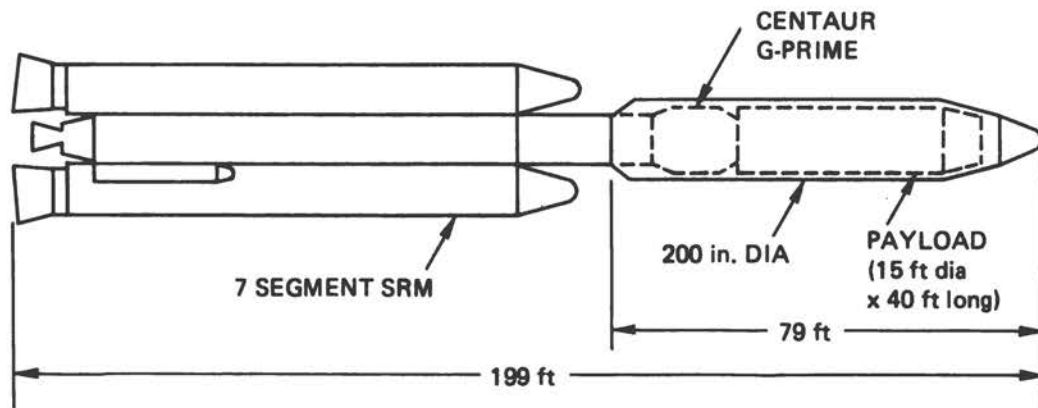

Figure courtesy USAF

Figure 4 Titan 34D7/Centaur

THE TITAN 34D7

The Titan 34D7/Centaur is an upgraded Titan IIIIE vehicle, which was used successfully in NASA planetary programs in the late 1970s. The solid rocket stack of the first stage has been increased from 5.5 to 7 segments, the tanks on the second- and third-stage liquid rocket engines are increased in length, and the new Centaur G' rocket forms the fourth stage. A seven-segment solid rocket similar to the one projected for the Titan 34D7, the Titan III M, was under development in 1966-68 for application on the Air Force Manned Orbiting Laboratory (MOL) and 4 test firings were made with varying degrees of success before the program was terminated. Although the structural modifications are lesser than those for the Atlas, there is still development risk.

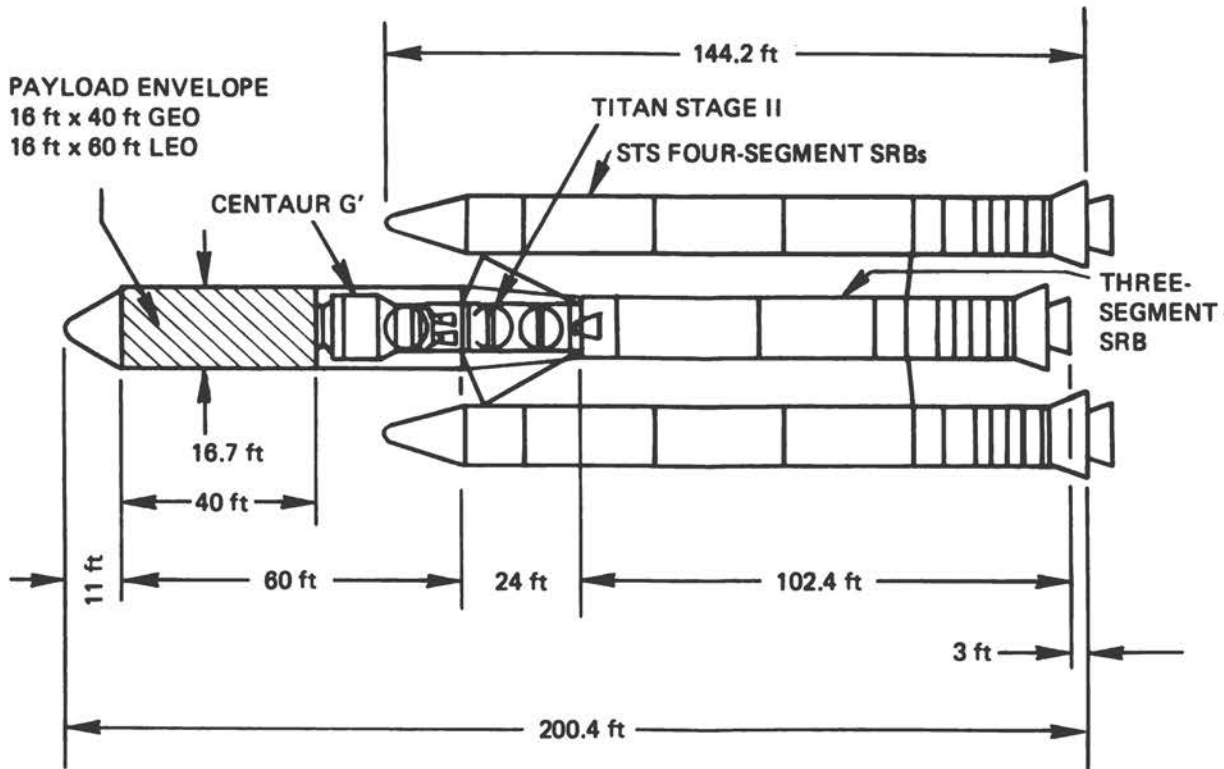

Figure courtesy NASA

Figure 5 SRB-X/Centaur

THE SRB-X

The SRB-X launch vehicle system is also an assemblage of rockets developed in other vehicles and proven in many successful flights. The first stage consists of 2 four-segment solid rockets identical with the first stage of the shuttle. The second stage is a three-segment variation of the first solid stage with a modification to the burning rate of the rocket fuel. The third stage is essentially an unmodified version of a standard Titan second stage. The upper (fourth) stage is a Centaur rocket identical to the one under development for the shuttle. However, because the first-stage Solid Rocket Boosters have been spaced to utilize STS launch facilities, development of a truss will be required making the SRB-X, like the Atlas II, essentially a new launch vehicle with some corresponding risks.

TABLE I COMPARATIVE ELV DATA

	T34D7/CENT G'	ATLAS II/CENT G'	SRB-X/CENT G'
Liftoff Weight (lb)	1.91 X 10 ⁶	1.62 X 10 ⁶	3.74 X 10 ⁶
Liftoff Thrust (lb)	2.8 X 10 ⁶ (2 solids)	2.27 X 10 ⁶ (5 liquid engine + 4 solids)	5.80 X 10 ⁶ (2 solids)
Thrust/Weight	1.46	1.40	1.55
Trajectories			
Park Orbit (nmi*)	84 X 102	80 X 104	100 circular ⁺
Transfer (nmi)	95 X 19,324	90 X 19,421	100 X 19,323 ⁺
Performance to Geo. (lb)	10,500	11,000	11,500

*Nautical miles

⁺NASA figures

Courtesy of The Aerospace Corporation

LAUNCH FACILITIES

The Air Force proposes to modify the Titan III Launch Complex 41 at the Eastern Space and Missile Center for launch of either the Titan 34D7/Centaur or the Atlas II/Centaur. Rework of the area and its equipment will be required for either vehicle, but the modifications for the Atlas II will be more extensive than those for the Titan. Complex 41 has not been in use since the Titan III planetary launching in 1977 and maintenance has been minimal. Rework or replacement of the stand, the mobile service tower, the umbilical tower, and the associated equipment and instrumentation will be required.

The SRB-X would be launched from the shuttle Launch Pad 39B at Kennedy Space Center requiring some modifications to its fixed and rotating service structures. Modifications will also be necessary for one high bay cell of the Vehicle Assembly Building and for the Mobile Launch Platform. A hypergolic fuel system will be needed for the third stage. As noted above, the four-segment solid rocket motors of the first stage have been spaced as on the shuttle so that the exhaust vents on the shuttle mobile launch platform may be used without modification.

ADVANTAGES AND DISADVANTAGES

The unit costs and technical capability of the 3 systems examined appear to be comparable. As stated in the Introduction, the Air Force is currently considering bids for such a system and, hence, it is inappropriate for the panel to comment further. Air Force procurement procedures should be adequate to select an appropriate configuration to meet military requirements. However, some general observations might be made without prejudicing the procurement process.

The Titan 34D7 uses largely proven hardware and obtains growth through elements previously demonstrated. It can use Launch Complex 41 at Cape Canaveral, thus making it independent of the STS launch facilities. This avoids possible bottlenecks that might arise if the STS launch pads were used, thus presenting a decided advantage for timely assured access to space.

The Atlas growth version is largely a new vehicle although based on proven Atlas technology. It shares many of the advantages of the Titan, e.g., use of developed engines and Launch Complex 41. However, it represents a larger departure from existing designs.

The SRB-X enjoys the synergism with the STS of using its solid rocket boosters (SRBs). The spacing between the external SRBs make the vehicle wider than otherwise necessary. The initial launch pad modification costs are comparable to costs of modifying Launch Complex 41; but there is a risk of tying up a critical facility and presenting a single failure node. The panel noted that the take-off weight of the SRB-X is approximately twice that of either of the other 2 ELVs while the costs appear to be comparable. When questioned, NASA representatives explained that the greater weight was due to the use

TABLE II ASSESSMENT OF CANDIDATE ELVS

	TITAN 34D7	ATLAS II	SRB-X
State of Technology	Proven	Proven	Proven
Development Risk	Low	Moderate	Low-Moderate
Availability*	1988	1988	1988
Launch Facilities	ESMC ¹ Launch Complex 41 reactivated & modified	ESMC Launch Complex 41 reactivated & modified	KSC ² Launch complex 39B modified
STS Payload Compatible	Yes	Yes	Yes
Estimated Weight to Geosynchronous Orbit	10,500 lb	11,000 lb	11,500 lb
Growth Potential	Approx. 10%	Approx. 10%	Approx. 10%
Cost Trade-offs	Insufficient data exist to draw valid distinctions between the three.		

*Agency estimates. Considered by the panel in all cases to be optimistic, particularly the Atlas II and SRB-X.

1. Eastern Space and Missile Center 2. Kennedy Space Center

TABLE II ASSESSMENT OF CANDIDATE ELVS (Continued)

	TITAN 34D7	ATLAS II	SRB-X
ADVANTAGES	Separate launch facility from STS	Separate launch facility from STS	Utilizes SRB from STS and common launch facility, thus potentially reducing total STS/SRB-X costs
	Less operational complexity	Less operational complexity	
	Greater operational security at less cost	Greater operational security at less cost	
	Broader industrial base	Broader industrial base	
DISADVANTAGES	Requires maintenance of separate pad & launch teams for only 2 launches/year	Requires maintenance of separate pad & launch teams for only 2 launches/year	Shared pad potentially jeopardizes both STS and SRB-X
			Dependent on complex STS launch operations

of larger solid rockets for the first stage and a solid second stage, and the costs were not proportionally greater because of the reusable features of the first stage and the advantage of a broadened production base for the SRBs that are used for both first and second stages of the SRB-X.

Each of these vehicles, once developed, offers the possibility of application to non-DoD missions now allocated to the STS; this raises policy questions not addressed by this panel.

None of the 3 candidate systems appears to have any significant growth potential* without major reconfiguration. Nor do any of the candidate vehicles require development of new technology. A summary assessment of the 3 systems is presented in Table II.

COST CONSIDERATIONS FOR CANDIDATE ELVs

The panel was provided with preliminary NASA and Air Force cost estimates for the 3 candidate systems. Some of the information is proprietary and subject to refinement in the course of the on-going Air Force procurement actions. Therefore, specific dollar figures are not used herein.

Documentation available to the panel was insufficient to resolve discrepancies in NASA and Air Force cost estimates; what breakdowns were available indicate that there are considerable differences in the cost estimation processes. However, the differences are not regarded as significant compared to the estimates for the total expense of the national space launch system.

In the opinion of the panel, incremental costs to the nation's launch program of the order of \$2 billion for the launches during the 5-year period should be contemplated no matter which vehicle system is chosen. A portion of this sum would be offset in the Air Force budget by elimination of 10 DoD-scheduled STS launches, but commercial costs and costs to NASA will be higher unless the vacated military flights can be sold to other customers.

*Herein, "growth potential" is taken to mean the inherent ability to modify or upgrade performance of a space booster without a complete redesign of the entire system.

VI

Future Heavy Lift Launch Vehicles

As indicated earlier, there currently exists no validated requirement for launch vehicles with performance exceeding the STS/Centaur or proposed complementary ELVs. However, it is understood that future DoD missions may require launching large payloads such as those associated with surveillance, communications, and the Strategic Defense Initiative (Reference 7). For example, the SDI missions may require payloads in the range of 130,000 to 200,000 lb (Reference 8) and there may be a requirement for launching very large payloads such as "tankers" for logistics support to future space operations (e.g., Reference 9) and explorations. It is the panel's judgement, based on the historical growth of satellite systems, that on-orbit weight is highly leveraged into improved systems performance.

Regarding use of heavy lift by the commercial sector, the communications capacity of satellites is currently growing more rapidly than their weight. Somewhat larger satellites may be developed in coming years (e.g., for future Intelsats) because they might be more cost effective and, even more importantly, because space in geosynchronous orbit is rapidly becoming scarce. The STS-Centaur provides for growth up to 10,000 lb. Beyond that, larger and heavier payloads are not likely to be developed until suitable launch vehicles are available.

HEAVY LIFT VEHICLE CONCEPTS

In order to meet potential long-term needs, both NASA and the U.S. Air Force are pursuing studies of a number of unmanned launch vehicles with payload lift capabilities up to 450,000 lb to low earth orbit and up to 140,000 lb to geosynchronous orbit. In the present studies, payload sizes of at least 25 ft in diameter and 90 ft in length could be accommodated. These vehicles all utilize components of the space shuttle in some form such as solid rocket boosters (SRB), space shuttle main engines (SSME), external tank (ET) sections, and an unmanned orbiter derivative cargo carrier, and, therefore, represent existing technology.

Two classes of vehicles are under consideration, an "in-line" cargo vehicle and a "side-mount" configuration, some versions of which are shown in Figures 6 and 7.

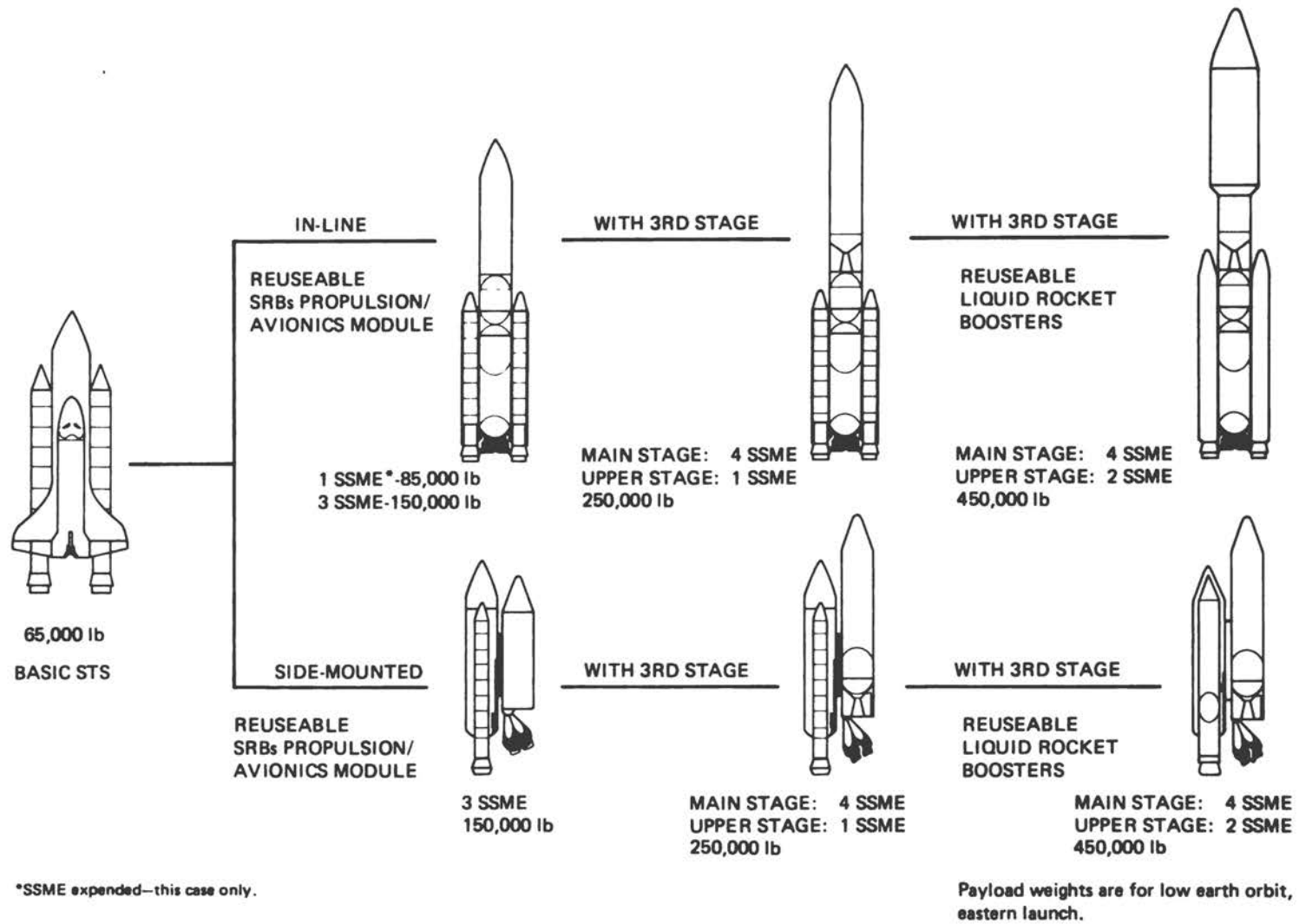

Figure 6 Potential Heavy Lift Vehicles (NASA)

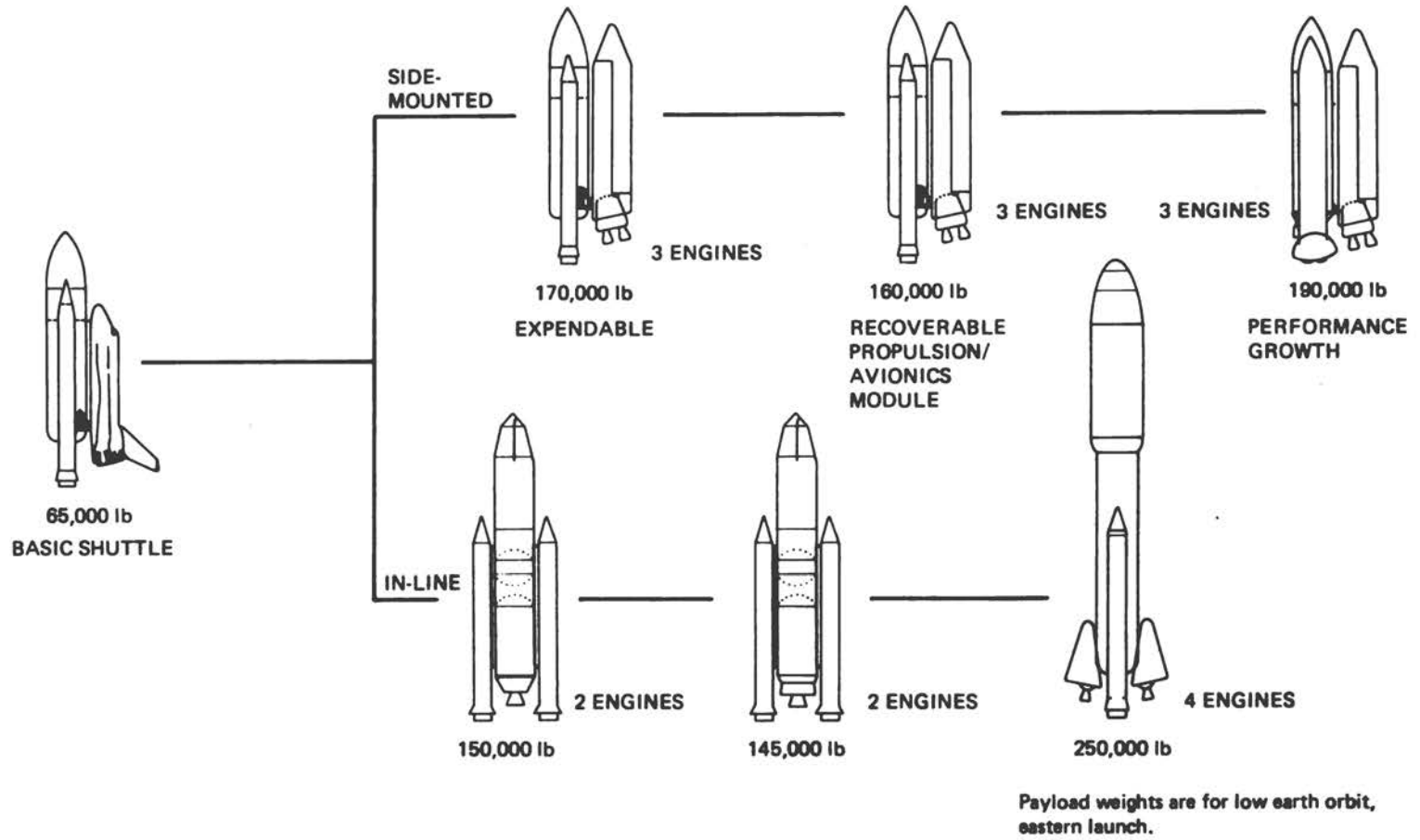

Figure 7 Potential Heavy Lift Vehicles (U.S. Air Force)

The panel considers these unmanned launch vehicle (ULV) concepts as viable candidates to meet future heavy lift launch requirements. The panel endorses the ULV study programs but notes that they do not appear likely to result in any significant improvement in cost per pound to orbit.

The panel therefore stresses the need for new research and development in launch vehicle technology with particular attention to lowering cost to orbit in addition to the usual goals of performance and reliability. Since efficient upper stages reduce the size and cost of lower stages, use of high-energy propellants for additional stages should be explored. In general, more emphasis is needed on liquid rocket technology.

It should be noted that once technology readiness is achieved, the development cycle for a future heavy lift launch vehicle would normally span 5 to 7 years.

As a final note, the panel believes the nation should look beyond the immediate requirement for complementary ELVs and begin to lay plans for the next generation of launch vehicles with greater lift capability. It further observes that over the years NASA and the DoD have worked closely together to jointly define U.S. space launch vehicle needs and strongly endorses this process for future launch vehicles.

VII

Findings

Consistent with the specific charge, which was to examine candidate complementary launch vehicles and heavy lift vehicle configurations, the panel offers the following findings:

Complementary ELVs

1. The complementary ELV as a means to a more assured access to space has unique attributes of operational flexibility and security not provided by the STS alone.
2. The 3 candidates presented by government agencies to the panel (the Atlas II, Titan 34D7, and SRB-X) were judged to be roughly equivalent in cost, schedule, reliability, and payload-to-orbit performance. None of the 3 requires new technology. None has significant growth potential.
3. The Atlas II and Titan 34D7 have an important advantage over the SRB-X in assuring timely access to space in that they are launched independently of the complex STS launch environment.
4. Inasmuch as the STS is to remain the nation's principal access to space, it is essential that both DoD and NASA continue strong efforts to develop it into a mature operational system.

Heavy Lift Vehicles

1. There are presently no validated requirements that exceed the launch capability of the shuttle or complementary launch vehicles.
2. DoD and NASA studies indicate the possible future need for launch vehicles with capabilities equivalent to placing in low earth orbit payloads in excess of 200,000 lb.

3. These capabilities can be satisfied by the application of existing shuttle components and technology used in unmanned configurations.
4. Efforts are required to reduce substantially the cost per pound to orbit by the development and application of advanced technologies, simplified design, and improved operational procedures without loss of reliability.

References

1. The White House. July 4, 1982. Fact Sheet, "National Space Policy." Office of the White House Press Secretary.
2. Public Law 98-52, 98th Congress, July 15, 1983.
3. National Research Council. 1983. Assessment of Constraints on Space Shuttle Launch Rates. Washington, D.C.: National Academy Press.
4. Space Task Group. February 1969. "Report of the Space Transportation Committee."
5. National Aeronautics and Space Administration. 1983. NASA Advisory Council Study of Effective Shuttle Utilization. Washington, D.C.
6. C. Weinberger (Preface). 1984. Soviet Military Power. Washington, D.C.: Superintendent of Documents, U.S. Government Printing Office.
7. Defensive Technologies Study Team. October 1983. "Report on the Study of Eliminating the Threat Posed by Nuclear Ballistic Missiles."
8. Headquarters Space Division, Air Force Systems Command. February 10, 1984. "Complementary Space Launch Strategy for Assured Access to Space."
9. National Research Council. 1981. Electric Power from Orbit: A Critique of a Satellite Power System. Washington, D.C.: National Academy Press.



Appendix

Appendix A

MAJORITY MEMBERS

JAMIE L. WHITTEN, MISS., CHAIRMAN
EDWARD P. BOLAND, MASS.
WILLIAM H. RATCHER, KY.
NEAL SMITH, IOWA
JOSEPH P. ADDABO, N.Y.
CLARENCE D. LONG, MD.
BONEY R. YATES, ILL.
DAVID R. OBEY, WIS.
EDWARD R. ROYBAL, CALIF.
LOUIS STOKES, OHIO
TOM SEVILL, ALA.
BILL CHAPPELL, JR., FLA.
BILL ALEXANDER, ARK.
JOHN P. BURTTNA, PA.
BOB TRAXLER, MICH.
JOSEPH D. EARLY, MASS.
CHARLES WILSON, TEX.
LINDY BARR, HALB. BOGGS, LA.
NORMAN D. DICKS, WASH.
MATTHEW F. MC HUGH, N.Y.
WILLIAM LEHMAN, FLA.
JACK HIGHTOWER, TEX.
MARTIN CLAY BASSO, MINN.
JULIAN C. DIXON, CALIF.
VIC FAZIO, CALIF.
W. G. (BILL) HEPNER, N.C.
LES AU'COM, OREG.
DANIEL K. AKAKA, HAWAII
WES WATKINS, OKLA.
WILLIAM H. GRAY II, PA.
BERNARD J. DWYER, N.J.
WILLIAM R. RATCHFORD, CONN.
BILL BONER, TENN.
STERY H. HOYER, MD.
BOB CARR, MICH.
ROBERT J. BRAZEK, N.Y.

Congress of the United States House of Representatives Committee on Appropriations Washington, D.C. 20515

January 25, 1984

MINORITY MEMBERS

SILVIO G. COYTE, MASS.
JOSEPH M. MC BADE, PA.
JACK EDWARDS, ALA.
JOHN T. MYERS, IND.
J. KENNETH ROBINSON, VA.
CLARENCE E. MILLER, OHIO
LAWRENCE COUGHLIN, PA.
C. W. BILL YOUNG, FLA.
JACK F. KEMP, N.Y.
RALPH REGULA, OHIO
GEORGE H. O'DRISCOLL, ILL.
VIRGINIA SMITH, MISS.
ELDON RUDD, ARIZ.
CARL D. PURSELL, MICH.
BICKLEY EDWARDS, OKLA.
BOB LIVINGSTON, LA.
BILL GREEN, N.Y.
TOM LOSPILER, TEX.
JERRY LEWIS, CALIF.
JOHN EDWARD PORTER, ILL.
HAROLD ROOBBS, KY.

CLERK AND STAFF DIRECTOR
KEITH F. MAINLAND

TELEPHONE
(202) 225-2771

Honorable James M. Beggs
Administrator
National Aeronautics and Space
Administration
400 Maryland Avenue, Southwest
Washington, D. C. 20546

Dear Mr. Administrator:

In recent years both NASA and the Air Force have worked on advanced expendable vehicle configurations that could increase payload to orbit at potentially reduced costs and provide a flexible backup for the space transportation system. Some of these potential configurations are shuttle derived expendable launch vehicles (ELV) in that they employ current or modified shuttle systems such as the solid booster, external tank and main engines. Other configurations include an advanced seven segment Titan and a new Atlas.

It appears that the state of analysis has reached a point where definition studies may now be initiated -- looking to the most promising candidate for this role. In view of the array of possible shuttle derived and non-shuttle derived candidates; and the complexity of economic, technical and future mission considerations, the Congress would benefit from an early, independent assessment of the advantages and disadvantages of candidate ELV vehicles to perform various alternative mission scenarios. The Appropriation Committees are particularly concerned with the potential payload capabilities; development time; additional ground support requirement for various candidate systems; payload compatibility between the shuttle and candidate ELVs; cost trade offs between the candidate systems -- including the effect of such systems on the total cost of maintaining a national launcher capability.

The Appropriation Committees requests that NASA have the National Academy of Engineering establish an independent review committee to prepare a comprehensive assessment that will focus on the most effective candidates considering both realistic future mission requirements and the cost.

Honorable James M. Beggs
January 25, 1984
Page Two

It is requested that this study be submitted by September 1, 1984.

Thank you for your usual cooperation.



Jake Garn
Chairman
Senate Appropriations Subcommittee
on HUD-Independent Agencies

Sincerely,

Edward P. Boland
Chairman
House Appropriations Subcommittee
on HUD-Independent Agencies

Appendix B

STATEMENT OF TASK AN ASSESSMENT OF CANDIDATE EXPENDABLE LAUNCH VEHICLES FOR LARGE PAYLOADS

The National Academy of Sciences/National Academy of Engineering through the National Research Council contracted to furnish the National Aeronautics and Space Administration, through the NASA Chief Engineer, an assessment of Candidate Expendable Launch Vehicles for Large Payloads in response to Congressional request. This study is the fifth task under a broader contractual arrangement with NASA. In a letter dated January 25, 1984, from Senator Garn and Congressman Boland to the NASA Administrator, requesting the task, it was asked that the study be completed and its results submitted to the House and Senate Appropriations Committees by September 1, 1984.

To deal with the request for carrying out reviews of NASA programs, the NRC established the Committee on NASA Scientific and Technological Program Reviews in 1981. In order to address diverse problems, the Committee has been authorized to establish ad hoc review panels, of which this--the panel to assess Candidate Expendable Launch Vehicles--is the fifth.

The charge to the panel, based on the Congressional request, is to prepare an assessment of shuttle-class expendable launch vehicles with primary emphasis on 1) increased payload to orbit, 2) potentially reduced cost, and 3) provision of a flexible back-up for the space shuttle. Specifically requested is:

- o an assessment of future large payload requirements of NASA, DoD, and the private sector for standard launch vehicles and additional stages

- o an assessment of the advantages and disadvantages of candidate expendable launch vehicles, both shuttle-derived and other, to meet these requirements accounting for:
 - o system development time and risk
 - o ground support requirements
 - o ground facilities requirements
 - o payload compatibility with the shuttle
 - o growth potential for future mission concepts

- o cost trade offs between candidate systems, including the effect of such systems on the total cost of diversifying the national launch capability for large payload (comparable costs to be based on available estimates from appropriate organizations).

In carrying out this task, account should be taken of recent studies by the NRC, NASA, the Air Force and aerospace contractors. It is anticipated that NASA and USAF will provide information on their respective studies necessary to the conduct of this review.

It is requested that the task be completed and the report be forwarded to the Committee on NASA Scientific and Technological Program Reviews no later than August 1, 1984.

Committee on NASA Scientific and Technological Program Reviews
Washington, D.C.
February 24, 1984

Appendix C

COMMITTEE ON NASA SCIENTIFIC AND TECHNOLOGICAL PROGRAM REVIEWS

NORMAN HACKERMAN, President, Rice University, Houston, Texas, Chairman
RAYMOND L. BISPLINGHOFF, Retired Director for Research and
Development, Tyco Laboratories, Inc., Exeter, New Hampshire
GEORGE W. CLARK, Professor of Physics, Massachusetts Institute of
Technology, Cambridge, Massachusetts
EUGENE E. COVERT, Professor of Aeronautics, Massachusetts Institute of
Technology, Cambridge, Massachusetts
ALEXANDER H. FLAX, President Emeritus, Institute for Defense Analyses,
Alexandria, Virginia
THOMAS P. STAFFORD, Partner, Stafford, Burke, and Hecker, Inc.,
Alexandria, Virginia
JOHN W. TOWNSEND, Jr., President, Fairchild Space Company, Germantown,
Maryland
JAMES A. VAN ALLEN, Head, Department of Physics, University of Iowa,
Iowa City, Iowa
HERBERT FRIEDMAN, Chairman, Commission on Physical Sciences,
Mathematics, and Resources, National Research Council,
Washington, D.C., Ex Officio Member
MARTIN GOLAND, Chairman, Commission on Engineering and Technical
Systems, National Research Council, Washington, D.C., Ex Officio
Member

ROBERT H. KORKEGI, Executive Director
JOANN CLAYTON, Staff Officer
ANNA L. FARRAR, Administrative Assistant

Appendix D



THE SECRETARY OF DEFENSE
WASHINGTON, THE DISTRICT OF COLUMBIA

7 FEB 1984

MEMORANDUM FOR SECRETARIES OF THE MILITARY DEPARTMENTS
CHAIRMAN OF THE JOINT CHIEFS OF STAFF
UNDER SECRETARIES OF DEFENSE
ASSISTANT SECRETARIES OF DEFENSE
GENERAL COUNSEL

SUBJECT: Defense Space Launch Strategy

On 23 January 1984, I approved the attached Defense Space Launch Strategy. The approach described in this document will be used to guide future defense space launch planning. Please ensure maximum distribution to all those affected within your departments and agencies.

A handwritten signature in cursive script, which appears to read "James V. Hartung", is written over a horizontal line. To the right of the signature is a circled set of initials, "eos".

Attachment

54217

DEFENSE SPACE LAUNCH STRATEGYPOLICY

Defense space launch strategy has been developed in response to validated DoD assured space launch requirements and implements the launch policies contained in the National Space Policy and the Defense Space Policy. The National Space Policy identifies the Space Transportation System (STS) as the primary U.S. government space launch vehicle, but recognizes that unique national security requirements may dictate the development of special purpose launch capabilities. The Defense Space Policy states that:

"While affirming its commitment to the STS, DoD will ensure the availability of an adequate launch capability to provide flexible and operationally responsive access to space, as needed for all levels of conflict, to meet the requirements of national security missions."

REQUIREMENTS

The DoD has a validated requirement for an assured launch capability under peace, crisis and conflict conditions. Assured launch capability is a function of satisfying two specific requirements -- the need for complementary launch systems to hedge against unforeseen technical and operational problems, and the need for a launch system suited for operations in crisis and conflict situations. While DoD policy requires assured access to space across the spectrum of conflict, the ability to satisfy this requirement is currently unachievable if the US mainland is subjected to direct attack. Therefore, this launch strategy addresses an assured launch capability only through levels of conflict in which it is postulated that the U.S. homeland is not under direct attack. Additional survivability options beyond an assured launch capability are being pursued to ensure sustained operations of critical space assets after homeland attack.

STRATEGY

Near Term: Existing Defense space launch planning specifies that DoD will rely on four unique, manned orbiters for sole access to space for all national security space systems. DoD studies and other independent evaluations have concluded that this does not represent an assured, flexible and responsive access to space. While the DoD is fully committed to the STS, total reliance upon the STS for sole access to space in view of the technical and operational uncertainties, represents an unacceptable national security risk. A complementary system is necessary to provide high confidence of access to space particularly since the Shuttle will be the only launch vehicle for all US space users. In addition, the limited number of unique, manned Shuttle vehicles renders them ill-suited and inappropriate for use in a high risk environment.

The solution to this problem must be affordable and effective and yet offer a high degree of requirements satisfaction, low technical risk, and reasonable schedule availability. Unmanned, expendable launch vehicles meet these criteria

and satisfy DoD operational needs for a launch system which complements the STS and extends our ability to conduct launch operations further into the spectrum of conflict. These systems can provide unique and assured launch capabilities in peace, crisis and conflict levels short of General Nuclear war. These vehicles are designed to be expendable and the loss of a single vehicle affects only that one mission and would not degrade future common, national launch capabilities by the loss of a reusable launch system.

The President's policy on the Commercialization of Expendable Launch Vehicles states that the goals of the U.S. space launch policy are to ensure a flexible and robust U.S. launch posture, to maintain space transportation leadership, and to encourage the U.S. private sector development of commercial launch operations. Consistent with this policy, the DoD will pursue the use of commercially procured ELVs to meet its requirements for improving its assured launch capabilities. For requirements that cannot be satisfied by commercially available ELVs, unique DoD developments may be undertaken for special purpose launch capabilities.

The STS will remain the primary launch system for routine DoD launch services. Unmanned, expendable launch vehicles represent a complementary capability to the STS and will be maintained and routinely launched to ensure their operational viability. To accomplish this, selected national security payloads will be identified for dedicated launch on ELVs, but will remain compatible with the STS.

Long Term: While commercial expendable launch vehicles represent an affordable and available solution to the unique DoD space launch requirements into the early-1990s, the need for other DoD launch capabilities to meet requirements beyond then must be evaluated and validated. This effort must be initiated immediately in order to ensure that future national security space missions are not constrained by inadequate launch capability. The evaluation should examine potential DoD launch requirements, such as the need for a heavy lift vehicle, and should attempt to take maximum advantage of prior investments in the U.S. launch vehicle technology base.

IMPLEMENTATION

As Executive Agent for launch vehicles, the Air Force will take immediate action to acquire a commercial, unmanned, expendable launch vehicle capability to complement the STS with a first launch availability no later than FY 1988. These vehicles must provide a launch capability essentially equal to the original STS weight and volume specifications.

In addition, the Air Force, in conjunction and coordination with other Services, affected agencies and departments, will:

- a) identify specific national security systems that will be used on the commercially procured expendable launch vehicles and the proposed peacetime launch rate required to maintain an operationally responsive posture.

- b) develop a comprehensive space launch plan to meet projected national security requirements through the year 2000. This strategy will be submitted to the Secretary of Defense for approval and validation.

The Defense Space Launch Strategy will be reflected in the FY-86 Defense Guidance Plan.

Appendix E

PARTICIPANTS IN BRIEFING SESSIONS

NASA PERSONNEL

Hans Mark, Deputy Administrator
Robert E. Austin, Chief, Space Transportation Group, Program
Development Office, Marshall Space Flight Center
Ivan Bekey, Director, Advanced Programs, Office of Space Flight, NASA
Headquarters
Charles R. Darwin, Director, Preliminary Design Office, Program
Development Office, Marshall Space Flight Center
Lawrence K. Edwards, Chief, Advanced Transportation, Office of Space
Flight, NASA Headquarters
Thomas A. Feaster, Manager, Advanced Studies, Future Projects Office,
Kennedy Space Center
Isaac T. Gillam IV, Assistant Associate Administrator for Customer
Relations and Policy, Office of Space Flight, NASA Headquarters
William R. Marshall, Director, Program Development Office, Marshall
Space Flight Center
Philip O'Neil, Special Assistant to the Deputy Administrator, Office
of Space Flight, NASA Headquarters
Milton A. Page, Advanced Transportation, Office of Space Flight, NASA
Headquarters
Lewis L. Peach, Jr., Special Assistant to the Deputy Administrator,
NASA Headquarters
William S. Rutledge, Chief, Engineering Cost Group, Program Planning
Office, Marshall Space Flight Center
Billy W. Shelton, Branch Chief, Systems Integration Branch, Program
Development Office, Marshall Space Flight Center
Milton A. Silveira, Chief Engineer, NASA Headquarters
Harry Sonnemann, Deputy Chief Engineer for Systems Engineering and
Technology, NASA Headquarters
Mack Steel, Director, Resources and Institutions, Office of Space
Flight, NASA Headquarters
L. Michael Weeks, Deputy Associate Administrator (Technical), Office
of Space Flight, NASA Headquarters

U.S. AIR FORCE PERSONNEL

- Charles W. Cook, Deputy Assistant Secretary of the Air Force for Space Plans and Policy, The Pentagon
- Col. Sebastian F. Coglitore, Deputy to Dr. Cook, The Pentagon
- Capt. Steven D. Jacques, Program Element Monitor, Expendable Launch Vehicles, Space Launch and Control Division, Directorate of Space Systems and Command, Control, Communications, DCS, Research, Development and Acquisition, Headquarters U.S. Air Force, The Pentagon
- Col. John W. Mansur, Military Assistant to the Under Secretary of the Air Force, The Pentagon (formerly Chief, Space Launch and Control Division, Directorate of Space Systems and Command, Control, Communications, DCS, Research, Development and Acquisition, Headquarters U.S. Air Force, The Pentagon)
- Maj. Thaddeus W. Shore, Assistant for the Defense Space Operations Committee, The Pentagon
- Brig. Gen. Donald J. Kutyna, Director for Space Systems and Command, Control, Communications, DCS, Research, Development and Acquisition, Headquarters U.S. Air Force, The Pentagon (formerly Deputy Commander for Launch and Control Systems, Headquarters Space Division, Los Angeles)
- James R. Barnum, Cost Analyst (Statistician), Deputy for Controller, Headquarters, Space Division
- Maj. Steven R. Kraemer, Assistant for Plans and Projects, Deputy Commander for Launch and Control Systems, Headquarters, Space Division

STRATEGIC DEFENSE INITIATIVE ORGANIZATION

- Lt. Col. George Hess, Acting Assistant Director, Supporting Technologies

U.S. DEPARTMENT OF THE NAVY

- Franklin W. Diederich, Technical Director, Navy Space Project

DEFENSE ADVANCED RESEARCH PROJECTS AGENCY

- Robert S. Cooper, Director