



Anchor Chain for Future U.S. Navy Vessels (1980)

Pages
58

Size
8.5 x 10

ISBN
030933182X

Committee on Anchor Chain Manufacture; National Materials Advisory Board; Commission on Sociotechnical Systems; National Research Council

 [Find Similar Titles](#)

 [More Information](#)

Visit the National Academies Press online and register for...

- ✓ Instant access to free PDF downloads of titles from the
 - NATIONAL ACADEMY OF SCIENCES
 - NATIONAL ACADEMY OF ENGINEERING
 - INSTITUTE OF MEDICINE
 - NATIONAL RESEARCH COUNCIL
- ✓ 10% off print titles
- ✓ Custom notification of new releases in your field of interest
- ✓ Special offers and discounts

Distribution, posting, or copying of this PDF is strictly prohibited without written permission of the National Academies Press. Unless otherwise indicated, all materials in this PDF are copyrighted by the National Academy of Sciences.

To request permission to reprint or otherwise distribute portions of this publication contact our Customer Service Department at 800-624-6242.

Copyright © National Academy of Sciences. All rights reserved.

**NATIONAL RESEARCH COUNCIL
COMMISSION ON SOCIOTECHNICAL SYSTEMS
NATIONAL MATERIALS ADVISORY BOARD**

Chairman:

Mr. William D. Manly
Senior Vice President
Cabot Corporation
125 High Street
Boston, MA 02110

**Past
Chairman:**

Mr. Julius J. Harwood
Director, Materials Science
Laboratory
Engineering and Research Staff
Ford Motor Company
P. O. Box 2053
Dearborn, MI 48121

Members

Dr. George S. Ansell
Dean, School of Engineering
Rensselaer Polytechnic Institute
Troy, NY 12181

Dr. H. Kent Bowen
Professor, Ceramic and Electrical
Engineering
Massachusetts Institute of Technology
77 Massachusetts Avenue
Cambridge, MA 02139

Dr. Van L. Canady
Senior Planning Associate
Mobil Chemical Company
150 E. 42nd Street, Room 746
New York, NY 10017

Dr. George E. Dieter, Jr.
Dean, College of Engineering
University of Maryland
College Park, MD 20742

Dr. Joseph N. Epel
Director, Plastics Research and
Development Center
Budd Corporation
356 Executive Drive
Troy, MI 48084

Dr. Larry L. Hench
Professor and Head
Ceramics Division
Department of Materials Science
and Engineering
University of Florida
Gainesville, FL 32601

Dr. Robert E. Hughes
Professor of Chemistry
Executive Director, Materials
Science Center
Department of Chemistry
Cornell University
Ithaca, NY 14850

Dr. John R. Hutchins III
Vice President and Director of
Research and Development
Technical Staff Division
Corning Glass Works
Sullivan Park
Corning, NY 14830

Dr. Sheldon E. Isakoff
Director, Engineering Research and
Development Division
E. I. DuPont de Nemours & Co., Inc.
Wilmington, DE 19898

Dr. Frank E. Jaumot, Jr.
Director of Advanced Engineering
Delco Electronics Division
General Motors Corporation
P. O. Box 1104
Kokomo, IN 46901

Dr. James W. Mar
Professor, Aeronautics and
Astronautics
Building 33-307
Massachusetts Institute of Technology
Cambridge, MA 02139

Dr. Frederick T. Moore
Industrial Advisor
Industrial Development and
Finance Department
World Bank
1818 H Street, N.W., Room D422
Washington, DC 20431

Dr. R. Byron Pipes
Director, Center for Composite
Materials
Department of Mechanical and
Aerospace Engineering
University of Delaware
Newark, DE 19711

Dr. Allen S. Russell
Vice President-Science and
Technology
Aluminum Company of America
1501 Alcoa Building
Pittsburgh, PA 15219

Dr. John J. Schanz, Jr.
Senior Specialist
Congressional Research Service-ENR
Library of Congress
Washington, DC 20540

Dr. Arnold J. Silverman
Professor, Department of Geology
University of Montana
Missoula, MT 59801

Dr. Dorothy M. Simon
Vice President and Director
of Research
AVCO Corporation
1275 King Street
Greenwich, CT 06830

Dr. William M. Spurgeon
Director, Manufacturing and
Quality Control
Bendix Corporation
24799 Edgemont Road
Southfield, MI 48075

Dr. Roger A. Strehlow
Professor, Aeronautical and
Astronautical Engineering
University of Illinois at Urbana
101 Transportation Building
Urbana, IL 61801

Dr. Michael Tenenbaum
1644 Cambridge
Flossmoor, IL 60422

Dr. William A. Vogely
Professor and Head, Department
of Mineral Economics
Pennsylvania State University
University Park, PA 16802

Dr. Albert R. C. Westwood
Director, Martin Marietta Labs
Martin Marietta Corporation
1450 South Rolling Road
Baltimore, MD 21227

NMAB Staff

W. R. Prindle, Executive Director
R. V. Hemm, Executive Secretary

BIBLIOGRAPHIC DATA SHEET	1. Report No. NMAB-371	2.	3. Recipient's Accession No.
4. Title and Subtitle Anchor Chain for Future U.S. Navy Vessels		5. Report Date June 1980	
7. Author(s) Committee on Anchor Chain Manufacture		8. Performing Organization Rept. No. NMAB-371	
9. Performing Organization Name and Address National Materials Advisory Board National Academy of Sciences 2101 Constitution Ave., N.W. Washington, D.C. 20418		10. Project/Task/Work Unit No.	
		11. Contract/Grant No. MDA 903-78-C-0038	
12. Sponsoring Organization Name and Address Department of Defense and the National Aeronautics and Space Administration		13. Type of Report & Period Covered Final Report	
		14.	
15. Supplementary Notes			
16. Abstracts Large anchor chain used by the U.S. Navy has been made by the die lock forging process developed at the Boston Naval Shipyard. This facility has been closed, and no commercial manufacturer in this country is currently making chain of the size needed (4-3/4 in.) for large aircraft carriers. The options open to the Navy are discussed. These options include the manufacture of die lock chain by industry, utilizing the dies being stored by the Navy. Welded chain could be made in the United States or purchased abroad. For the long term, the committee recommends the rapid development of welded chain, starting with the smaller sizes, for use by the Navy. The immediate problem, supplying chain to carriers under construction or expected to be built soon, should be solved by a resumption of die lock chain manufacture if equipment (large presses, heat treating furnaces, and chain transport), dies, and skills are available.			
17. Key Words and Document Analysis. 17a. Descriptors Aircraft carriers Anchors Chain Flash welding Forging Nondestructive examination Welding			
17b. Identifiers/Open-Ended Terms			
17c. COSATI Field/Group			
18. Availability Statement This report is for sale by the National Technical Information Service, Springfield, Virginia 22151.		19. Security Class (This Report) UNCLASSIFIED	21. No. of Pages 49
		20. Security Class (This Page) UNCLASSIFIED	22. Price

Anchor Chain for Future U.S. Navy Vessels

80-0042 ✓
National Materials Advisory Board (NRC), Washington, DC,*Department of Defense, Washington, DC.*National Aeronautics and Space Administration, Washington, DC. (045528000)

Final rept.

G2054A1 Fld: 13J, 15E, 47A GRAI8021

Jun 80 55p

Rept No: NMAB-371

Contract: MDA 903-78-C-0038

Sponsored in part by National Aeronautics and Space Administration, Washington, DC.

Abstract: Large anchor chain used by the U.S. Navy has been made by the die lock forging process developed at the Boston Naval Shipyard. This facility has been closed, and no commercial manufacturer in this country is currently making chain of the size needed (4-3/4 in.) for large aircraft carriers. The options open to the Navy are discussed. These options include the manufacture of die lock chain by industry, utilizing the dies being stored by the Navy. Welded chain could be made in the United States or purchased abroad. For the long term, the committee recommends the rapid development of welded chain, starting with the smaller sizes, for use by the Navy. The immediate problem, supplying chain to carriers under construction or expected to be built soon, should be solved by a resumption of die lock chain manufacture if equipment (large presses, heat treating furnaces, and chain transport), dies, and skills are available.

Descriptors: *Naval ships, *Ship anchors, *Chains, Fabrication, Military facilities, Nondestructive tests, Failure, Welded joints, Cost analysis, Aircraft carriers

Identifiers: *Anchor chains, *Die lock forgings, NTISNASNRC, NTISDODN, NTISNASA

PB80-197940 NTIS Prices: PC A04/MF A01

AD-17096861

ANCHOR CHAIN FOR FUTURE U.S. NAVY VESSELS

Report of

Committee on Anchor Chain Manufacture

NATIONAL MATERIALS ADVISORY BOARD
Commission on Sociotechnical Systems
National Research Council

Publication NMAB-371
National Academy of Sciences
Washington, D.C.
1980

NAS-NAE
JUN 23 1980
LIBRARY

NOTICE

The project that is the subject of this report was approved by the Governing Board of the National Research Council, whose members are drawn from the Councils of the National Academy of Sciences, the National Academy of Engineering, and the Institute of Medicine. The members of the Committee responsible for the report were chosen for their special competences and with regard for appropriate balance.

This report has been reviewed by a group other than the authors according to procedures approved by a Report Review Committee consisting of members of the National Academy of Sciences, the National Academy of Engineering, and the Institute of Medicine.

This study by the National Materials Advisory Board was conducted under Department of Defense Contract No. MDA 903-78-C-0038 for the Department of the Navy.

This report is for sale by the National Technical Information Service, Springfield, Virginia 22151.

Printed in the United States of America.

ABSTRACT

Large anchor chain used by the U.S. Navy has been made by the die lock forging process developed at the Boston Naval Shipyard. This facility has been closed, and no commercial manufacturer in this country is currently making chain of the size needed (4-3/4 in.) for large aircraft carriers.

The options open to the Navy are discussed. These options include the manufacture of die lock chain by industry, utilizing the dies being stored by the Navy. Welded chain could be made in the United States or purchased abroad. For the long term, the committee recommends the rapid development of welded chain, starting with the smaller sizes, for use by the Navy.

The immediate problem, supplying chain to carriers under construction or expected to be built soon, should be solved by a resumption of die lock chain manufacture if equipment (large presses, heat treating furnaces, and chain transport), dies, and skills are available.

NATIONAL MATERIALS ADVISORY BOARD
COMMITTEE ON ANCHOR CHAIN MANUFACTURE

Chairman

C¹³ ✓ ADOLPH SCHAEFER, Executive Director, The Metal Properties Council, Inc.,
New York, New York.

Members

FRANCIS W. BOULGER, Consultant, Columbus, Ohio.

CHARLES DECKARD, Corporate Director-Special Projects, The Bendix
Corporation, Southfield, Michigan.

GENE GOODWIN, Metals & Ceramics Division, Oak Ridge National Laboratory,
Oak Ridge, Tennessee.

C. MONROE HART, Rear Admiral, U.S.N. (ret.), Eyring Research Institute,
Inc., Provo, Utah.

EDWARD NISBET, Supervisor, Product Metallurgy, National Forge, Irvine,
Pennsylvania.

PAUL W. RAMSEY, Manager, Welding Research and Development, A.O. Smith
Corporation, Milwaukee, Wisconsin.

ROBERT STOUT, Dean of the Graduate School, Lehigh University, Bethlehem,
Pennsylvania.

Liaison Representatives

BRUNO L. ALIA, Chief Surveyor, Metallurgy Department, American
Bureau of Shipping, New York, New York.

JACK W. BOLLER, Executive Director, Marine Board, National Research
Council, Washington, D.C.

RANDOLPH W. KING, Executive Officer, National Academy of Engineering
(formerly Executive Director, Marine Transportation Research Board,
National Research Council), Washington, D.C.

GEORGE PRENTICE, Naval Sea Systems Command, Department of the Navy,
Washington, D.C.

STEVEN ROUSH, U.S. Coast Guard Headquarters, Washington, D.C.

GEORGE SORKIN, Consultant (formerly of the Naval Sea Systems Command, Department of the Navy), Alexandria, Virginia.

NMAB Staff

Joseph R. Lane, Staff Metallurgist

CONTENTS

	<u>Page</u>
Chapter 1 - INTRODUCTION	1
Chapter 2 - CONCLUSIONS/RECOMMENDATIONS	5
Chapter 3 - TECHNICAL RISKS AND CONFORMANCE TO SPECIFICATIONS FOR INDUSTRIAL PRODUCTION OF BOTH DIE LOCK AND WELDED 4-3/4 IN. CHAIN	7
Military Specifications for Anchor Chain	7
Die Lock Chain	8
Flash-Butt-Welded Chain	9
Chapter 4 - NONDESTRUCTIVE EXAMINATION	13
Relevant Quality-Assurance Provisions	13
Incoming Bar	13
Chain Manufacture	13
Nondestructive Examination	14
Chapter 5 - FAILURE MODES	17
Introduction	17
Failures in Mooring Systems	17
Navy Experience with Forged Chain	17
Commercial Experience with Welded Chain	21
Causes of Failures in Anchor Chain	27
Chapter 6 - DIE LOCK- AND FLASH-WELDED CHAIN EXPERIENCE	37
Analysis Procedure	37
U.S. Navy Die Lock Chain Service Experience	37
Flash-Welded Chain Experience	40
Chapter 7 - ECONOMIC ASPECTS	43

TABLES AND FIGURES

		<u>Page</u>
Figure 1	Processing Steps for Forging Die Lock Steel Stud-Link Anchor Chain	2
Figure 2	Chain Manufacturing Sequence for Welded Stud Links	3
Table 1	Failures and Causes of Failures in Parts of Mooring Systems in all Navy Vessels During January 1954 Through June 1957	19
Table 2	Failures in Mooring Systems, by Categories, Listed in Navy Casualty Reports January 1, 1971 Through October 30, 1979	20
Table 3	Summary of Notes Concerning Reasons for Replacement of Forged Chain Links	22
Table 4	Failures in Mooring Equipment of Merchant Ships (Welded Chain)	23
Table 5	Mooring Equipment Defects and Failures in Navy and ABS Records, by Subsystem Involved	25
Table 6	Losses of Cables and Other Failures on Japanese Ships and Ship Losses in World Shipping	26
Table 7	Data From Laboratory Studies on Welded Anchor Chain	30
Table 8	Composition of Steel in Samples of 4-3/4 In. Flash-Butt-Welded Anchor Chain	33
Table 9	Data From Tests on Triplets of 4-3/4 In. Flash-Welded Alloy Steel Chain	34
Table 10	Defects and Failures of Ground Tackle in Aircraft Carriers, U.S. Navy, 1971-79	38
Table 11	Defects and Failures of Ground Tackle in Medium Sized Ships, U.S. Navy, 1971-79	39

Chapter 1

INTRODUCTION

The committee has made an assessment of the technical risks and probable conformance to U.S. Navy specifications of 4-3/4 in. stud-link steel anchor chain if made by private industry using closed-die-forging (die lock) or flash-butt-welding methods. In the forging process, two forgings are assembled, by hot pressing, to form a link. The manufacturing steps are indicated in Figure 1. During the assembly operation, the cold stem is mated to a hot socket, which is then drop-forged to make one integral link. This report is limited to 4-3/4 in. chain of the type suitable for large aircraft carriers.

This process of closed-die-forging of anchor chain was developed by the Boston Navy Yard more than 55 years ago, and commercial rights were sold to Baldt, Inc. However, the 4-3/4 in. anchor chain continued as a Boston Navy Yard product until the Navy Yard was closed in 1973. Baldt never made this size of chain because of the high cost of the dies and the limited amount of chain required by the Navy. The use of forged anchor chain for almost all Navy vessels has continued despite commercial availability of much less expensive flash-welded chain. Welded chain is used extensively by navies of other countries, commercial vessels, and for anchoring offshore oil platforms.

Flash-welded chain is available from sources outside the United States in this 4-3/4 in. size, but not from domestic suppliers. Manufacturing steps for welded chain are shown in Figure 2. Tests made by Battelle-Columbus Laboratories indicate that satisfactory welded chain can be made, and a U.S. Navy Specification was later issued based on Battelle recommendations.

Baldt, which makes welded chain in smaller sizes, has questioned the desirability of the Navy's switching from forged to welded chain, citing various technical risks present in the manufacture of flash-butt-welded anchor chain (lack of fusion, incomplete normalizing, underbead cracking because of stress concentration in stud weld, weld starts and stops, and variances caused by human error). Welded anchor chain is widely used for mooring of ships and oil rigs. Flash welding has been used for joining the ends of common links since 1943; the process was applied to high-strength materials (Grade 3 chain) in 1966. Facilities for producing flash-butt-welded anchor chain with link diameters of 4-3/4 in. are available in Japan, Norway, Scotland, Spain, and Sweden. Some of the facilities fabricate links with diameters of 6 in. or larger.

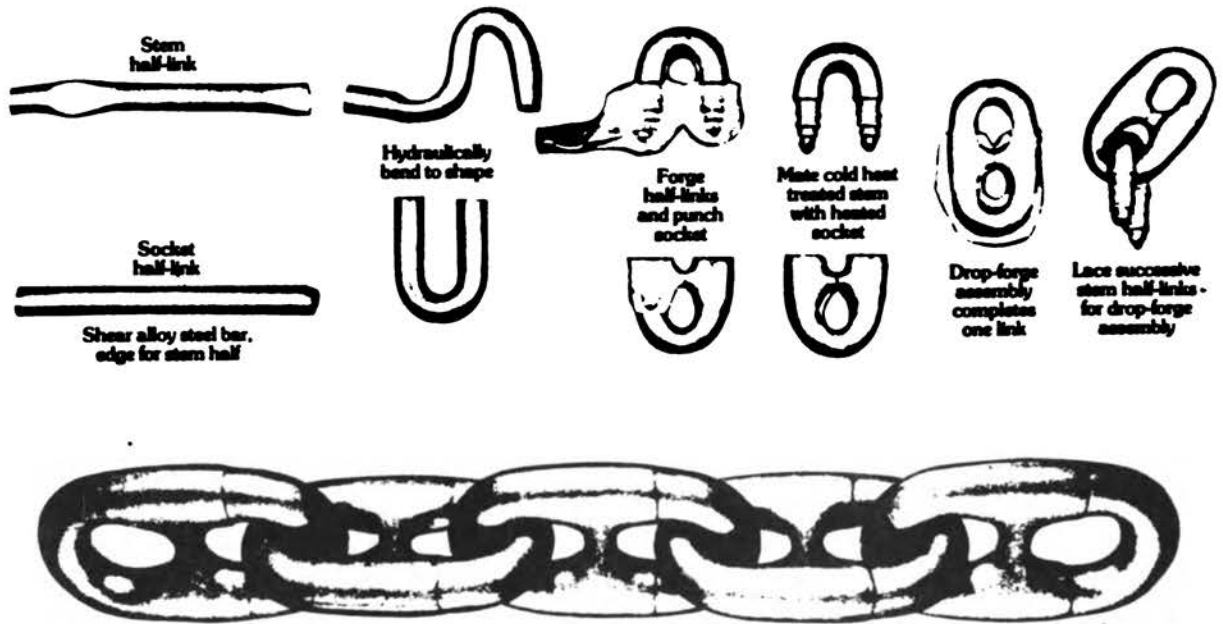
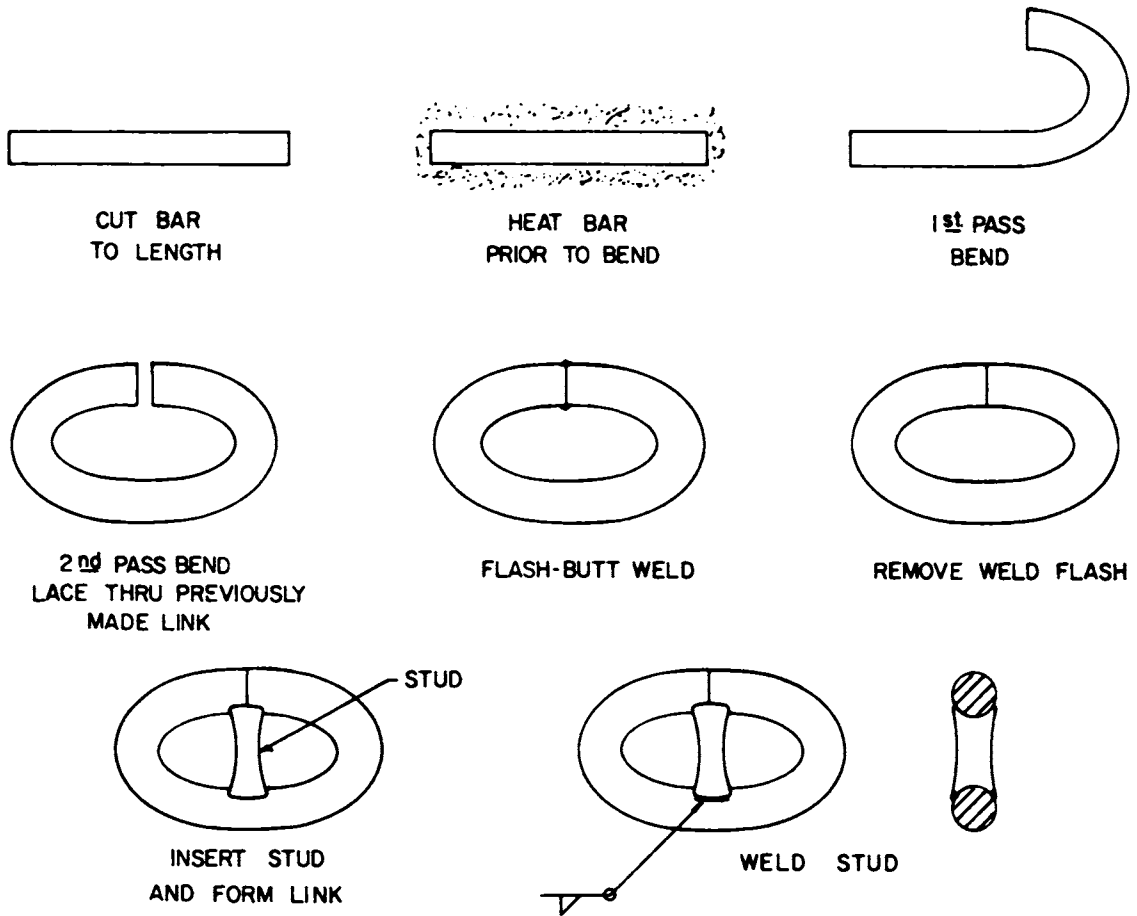

FIGURE 1 Processing Steps for Forging Die Lock Steel Stud-Link Anchor Chain. From CASREPT, 1979.



STUD IS PREVIOUSLY MADE AND OFFERED TO THE STUD PRESS FOR ASSEMBLY.

FIGURE 2 Chain Manufacturing Sequence for Welded Stud Links (From Baldt, Inc.)

Chapter 2

CONCLUSIONS/RECOMMENDATIONS

1. It is the consensus of the committee that it is technically possible to make 4-3/4 in. stud link steel anchor chain of adequate reliability using either the closed-die-forging method or the flash-butt-welding method. The technical risks with either method are well recognized from past experience and can be minimized by a well-qualified and properly administered shop.

2. Review of service experience available indicates that the die lock chain has been satisfactory and reliable in naval service, but there has been little U.S. Navy experience with welded chain. The service performance of flash-welded anchor chain used by the British Navy and by merchant ships from many countries has been good. Based on service records and mechanical property data, flash-butt-welded anchor chain is expected to perform reliably.

3. The background of satisfactory experience with die lock chain, in contrast with very limited experience with welded chain, together with the need for conservatism because of the critical importance of large aircraft carriers, indicates the advisability of providing the carriers under construction with die lock chain if this can be done. It has been reported that some forge shops in the United States with hammers of adequate capacity could be adapted (with the addition of chain handling equipment) at reasonable cost to make chain of this size. If existing dies can be utilized and adequate skills are available, advantage should be taken of the situation, and 4-3/4 in. chain manufactured by this method to satisfy immediate needs. Years of experience with forged anchor chain, and very little with welded chain, make it advisable, in the near term, to continue the use of the proven product in the largest and most critical size of chain, while production and service experience are developed with smaller size welded chain. When large welded chain ultimately becomes available, at first it could be attached to only one of the two anchors on a ship, with die lock on the other, to further ease the introduction. Forged chain can be expected to be more costly than welded chain; the cost differential would purchase assurance of satisfactory service while welded chain is undergoing qualification.

4. For the future the committee recommends that the Navy plan to utilize welded chain link for all sizes. This recommendation is based upon our judgement that inherently the welded link offers the possibility of superior quality and reliability at a lower cost. It is recommended that attention be given to the optimization of the selection of material, the manufacturing process and controls thereof, the specifications, and the design to produce the most reliable chain possible by the welded method. It is our opinion that modern process

control, as applied to the flash-welded type of link, presents the possibility of greater assurance of product reliability than can be achieved solely by existing nondestructive inspection techniques. In this connection, the current U.S. Navy specification MIL-C-24573(SH) appears to us to be satisfactory for this purpose. It should be utilized now for ships other than aircraft carriers, and periodically reviewed in the light of production and service experience.

5. The Navy is urged to acquire knowledge and experience in the utilization of welded type chain as quickly as possible by applying this product as opportunities present themselves. It is our recommendation that this experience and knowledge should preferably be gained by manufacture carried out in the United States.

Chapter 3

TECHNICAL RISKS AND CONFORMANCE TO SPECIFICATIONS FOR INDUSTRIAL PRODUCTION OF BOTH DIE LOCK AND WELDED 4-3/4 IN. CHAIN

MILITARY SPECIFICATIONS FOR ANCHOR CHAIN

The two primary specifications are MIL-C-19944 (Ships) 1 Oct 57—"Chain, Stud Link, Anchor, Die Lock Type, Heavy Duty, High Strength, and Standard," and MIL-C-24573 (Ships) 15 May 78—"Chain, 4-3/4 In. Stud Link, Anchor, Steel, Flash Butt Welded."

Comparison of Specifications

The welded-chain and forged-chain specifications for the 4-3/4 in. size are identical in making the following requirements:

Links per shot (90-foot length)	(57)
Weight per shot	(20,500 lb)
Length of six links	(122-1/2 in. nominal)
Chain breaking load	(2.55 million lb)
Chain proof load	(1.70 million lb)

Materials for forged chain are specified by composition (AISI 8623-Ni-Cr-Mo type) and normalized properties (tensile strength, 95,000 psi; tensile elongation, 18 percent; tensile elongation plus reduction in area, 56 percent), whereas for the welded chain, only properties are specified (yield strength, 68,000 psi; tensile elongation, 15.5 percent; reduction in area, 40 percent; V-notch Charpy, 40 ft.-lb. at 32°F). The Navy has indicated that AISI 1330 steel (C-Mn type) is to be used for welded chain.

Other specification differences of significance cover tests on completed chain. The forged chain must meet tensile-impact and compressive-impact requirements on actual links, whereas the tests on welded chain for impact, bend, and tensile properties are performed on specimens taken from the links.

Other differences in quality-assurance requirements are evident. Forged chain is visually examined for surface defects (burrs, overlaps, etc.), and a link is sectioned and etched for macroexamination of harmful defects. Welded chain requires visual inspection after proof testing to check for surface defects and cracks in the flash-weld area. A link is sectioned and etched for macroexamination. In addition, each link's flash weld is examined by magnetic-particle (or liquid-penetrant) means for defects after grit-blasting and proof

testing. One stud fusion-weld from each shot is similarly inspected after proof testing.

Factors Affecting Service

A review of failure data on anchor chain from the U.S. Navy and the American Bureau of Shipping indicates that some service problems occur in the following areas:

- Link Integrity - Failure of a link may cause damage or loss of vessel in storm or heavy seas. Failure of forged or welded links or connections is rarely the main cause of failure of the system.
- Worn Links - Dimensional changes eventually cause operational problems with anchor windlass. Periodic inspection will minimize this problem.
- Appendages - Although a study of these elements was not the committee's main assignment, it is significant that these appendages frequently are the parts of the ground-tackle system that produce the most problems.

DIE LOCK CHAIN

Quality Considerations

The forged chain has had excellent acceptance and more than 50 years of service experience. No problems have been reported for the 4-3/4 in. chain used for aircraft carriers.

It appears that the quality-assurance requirements, particularly the proof testing of each 90-ft. shot, have weeded out defective links. Defects mentioned in the specification include:

- Fracture under load
- Tendency to open at the lock under load
- Stretching beyond tolerances under load
- Surface defects—burrs, overlaps, flaws, or defects including rough surfaces that might cause kinking of the chain in service
- Internal defects detected by macroexamination of two cross sections—laps, seams, pipes, cracks, scale, fins, porosity, hard spots, nonmetallic inclusions, and segregation

Manufacturing Process

The closed-die-forging process for making anchor chain was developed by the Boston Navy Yard and used successfully for many years. Baldt also used the process under patent license from the government and has made chain for the Navy for many years. The die lock chain has had a wide variety of uses other than as anchor chain, including use in pickling operations, marine and mine railways, and drag buckets.

It was learned that Baldt is limited to equipment of 1.5 million lb. for proof testing, whereas 4-3/4 in. chain requires 1.7 million lb. This may have been a consideration in the seeking of another source to do the closed-die forging.

The committee has been informed by the Navy that the Chain Shop has been included in the area of the Boston Navy Yard which is now part of the Boston National Historical Park. This, together with the removal of some of the equipment, and the closeness to the Boston Redevelopment Authority property intended for residences, along with a question as to whether skilled workers could be rehired, makes the resumption of production here very improbable.

FLASH-BUTT-WELDED CHAIN

Quality Considerations

Flash-welded chain in 4 in. size or larger is being used by a number of navies outside the United States, by over 700 commercial ships world-wide (including some 300 classified by the American Bureau of Shipping), and for anchoring most offshore oil platforms. Reports of chain failure or damage in 1973-77 for American Bureau of Shipping vessels show only the following three instances of failure:

- Failure of an integral stud at a sharp radius but near the flash-weld line. This is a quite different design from that of the inserted stud specified in MIL-C-24573.
- Failure of the fifth link inboard while the ship was at anchor in heavy seas. The fourth link was elongated and cracked, indicating significant stressing.
- Seven bent links with no mention of cracking.

Types of defects mentioned in the MIL-C-24573 specifications include:

- Fracture under proof load.
- Cracks in the weld area after proof load

- When tested to failure, fracture occurring in flash-weld heat-affected zone
- Flash-weld misalignment larger than 3/32 in.
- Magnetic particle indications in excess of standard NAVSEA 0900-003-8000, Class 2, in the stud-fusion weld after grit blasting and proof testing
- Magnetic-particle indications in flash-weld area after grit blasting and proof testing
- Surface defects—burrs, rough edges, cracks, and cuts
- Internal defects detected by macroexamination of two cross sections—laps, seams, pipe, cracks, scale, fins, porosity, nonmetallic inclusions, and segregations
- Presence of Widmanstätten structure of any form in the microstructure of the flash-weld fusion zone.

Manufacturing Process

Information from anchor-chain manufacturers in the United States, Sweden, England, Germany, and Spain indicates that the flash-butt-welding process can produce acceptable chain that is capable of meeting MIL-C-24573 specifications.

Platen motion, current, and hydraulic pressure as a function of time must be carefully controlled in the flash-welding process. Fixturing is also critical to minimize misalignment.

Design Considerations

The normal failure when a breaking load is applied to a link is not in the flash weld (nor in the forged connection for die lock chain) but in the corner or end. An exception to this would be an obviously defective weld (or forged connection).

Discussion of Relative Risks in Materials, Processes, and Products

The evidence indicates that anchor chain of satisfactory quality for U.S. Navy use has been produced by both closed-die forging and flash-butt welding. A comparison of the materials, manufacturing methods, and end products will present this evidence in more detail.

Materials

The forged chain (MIL-C-19944, Type I, 4-3/4 in. chain) is made with AISI 8632 steel, which contains (in percentages):

0.30-0.35 C, 0.70-0.90 Mn, 0.040 max. P, 0.040 max. S, 0.20-0.35 Si, 0.40-0.70 Ni, 0.40-0.60 Cr, 0.15-0.25 Mo.

After heating to 2000°F,* held 10 min., and cooled in still air, its minimum tensile properties must be:

- tensile strength, 95,000 psi
- tensile elongation 18 percent
- tensile elongation plus reduction in area, 56 percent

Flash-butt-welded chain (MIL-C-24573) is made from a fine-grained steel, which must have these properties after being normalized:

- tensile strength, 68,000 psi
- tensile elongation, 15.5 percent
- reduction in area, 40 percent
- V-notch Charpy, 43 ft.-lbs. at 32°F

According to U.S. Navy information, AISI 1330 steel, which contains (in percentages),

0.28-0.33 C, 1.60-1.90 Mn, 0.035 max. P, 0.040 max. S, 0.15-0.30 Si

is used for flash-welded anchor chain.

Analysis by Battelle-Columbus of welded chain from four suppliers indicated that all samples were close to or within the above ranges, containing percentages of:

0.22-0.34 C, 1.59-1.72 Mn, 0.008-0.032 max. P, 0.019-0.035 max. S, 0.21-0.31 Si

Manufacturing Processes

The forging process developed by Boston Navy Yard has been an acceptable manufacturing technique for both the Navy and Baldt. Only the Navy has made 4-3/4 in. chain. In the event that forged chain were to be made in this size, there appear to be a number of well-qualified closed-die-forge shops in the United States that could produce a satisfactory product once they were equipped for making

*Metals Handbook, Vol. 2 (8th Ed., 1964). Page 13 gives 1650°F as a typical normalizing temperature for AISI 8630.

anchor chain. According to data published by the Forging Institute Association, there are at least eight such shops having the 25,000-lb. hammers required for producing forged chain.

The flash-butt welding of anchor chain of 4-3/4 in. size is currently done only in plants outside the United States. Battelle extensively tested links from four such plants in its laboratory evaluation (which led to development of the guidelines, manufacturing procedures, and quality-assurance testing requirements incorporated in MIL-C-24573). There is commercially available equipment for flash welding chain, a "merry-go-round" system with five stations (bending, flash welding, trimming, turning link, fitting stud). The flash-welding process has widespread use in industry, and there should be a number of shops in the United States capable of producing a satisfactory product once they were equipped for making anchor chain.

Products

Comparison of forged anchor chain and flash-butt-welded anchor chain under identical service conditions would obviously provide the greatest degree of information about their equivalence. Unfortunately, such data have not been found, nor does it seem likely that such data exists.

Based on data from the U.S. Navy, The American Bureau of Shipping, Battelle-Columbus, and Baldt, it is likely that, with existing quality- and process-control techniques, satisfactory welded anchor chain can be manufactured by private industry in the United States—just as it is abroad.

The preceding technical assessment has ignored two additional factors. First, the Navy is a conservative organization. In such an environment it should be expected that innovations will be adopted only over a period of time. Second, and more important, large aircraft carriers are extremely expensive (several billion dollars), and of incalculable value to the defense of the nation. With such an enormous investment at risk, it is only prudent to be ultraconservative with any equipment on which the safety of the ship may depend. Therefore, while the data show welded chain to be satisfactory, a case can be made for furnishing the large carriers at this time with forged chain, while experience with manufacture and use of welded chain on smaller ships is acquired.

Chapter 4

NONDESTRUCTIVE EXAMINATION

RELEVANT QUALITY-ASSURANCE PROVISIONS

The repetitive character of anchor-chain manufacture for both the forged die lock and flash-butt-welded types of chain makes process control an essential part of the quality-assurance program, and the results of nondestructive examination should be used as a guide for making manufacturing corrections. The practice of periodic inspection, however, is a most effective way of avoiding unexpected failures.

INCOMING BAR

Heat identification of the starting bar stock is important and should be traceable from the chain identification. Obviously each heat used should be capable of meeting the minimum mechanical property requirements of the chain specification after the required heat treatment.

It might be desirable to control the quality in terms of its manufacture, for example, the degree of reduction of strand-cast material. Nondestructive surface examination of the bar stock by the magnetic-particle or possibly by the eddy-current method would be of value in revealing surface seams or laps. Internal bar defects, such as center-line unsoundness, could be readily detected by ultrasonic examination.

CHAIN MANUFACTURE

Die Lock

The provisions of MIL-C-19944 have evidently enabled an adequate product to be made. Control of temperature in the various heating stages for the forging of the links should not be difficult to achieve, and the appearance of the link after forging and flash trimming probably gives a good guide to the effectiveness of the process, especially when the dimensions of the link are taken into account.

Flash-Butt-Welding

A chemical-analysis specification should be drawn up for welded chain when this system is used, just as has been done for die lock chain in MIL-C-19944 (Ships).

It is acknowledged that close control of the welding-machine settings is essential for obtaining consistent results. Probably most of the link defects in the investigation reports received by the committee reflect problems in the welding machine area, with the exception of fillet-weld defects in the stud when this method of assembly is used.

NONDESTRUCTIVE EXAMINATION

Die Lock

Radiography of die lock chain might be helpful in showing the outline of the forged joint. The technique would require some masking and would probably be relatively expensive and time consuming, especially for large chain. Except for examination of random links, this is probably not a practical test method for die lock chain.

Ultrasonic examination of die lock chain would yield little, if any, useful information because of the large reflecting surfaces in the joint areas.

Magnetic-particle examination of the circumferential joints in the die lock chain would give indications that would tend to mask any defects in these areas. Surface laps or seams from the original bar could be seen, and any tendency for these to split in the outer surface of the joints would be revealed.

Liquid-penetrant examination of die lock chain would be less satisfactory than magnetic-particle examination because of the extensive bleed-out from the circumferential joints, as well as the gap between the mating stud portions.

Flash-Butt-Welded Chain

Radiography should readily detect defects in their most likely location which is in the plane of the weld, at right angles to the axis of the bar. However, masking of the weld joint would be needed to equalize the exposure, and again the process would be time consuming and would require an area in which personnel can be protected from the radiation. There is a distinct possibility that a planar defect with opposing faces tightly pressed together would escape detection by radiography.

Ultrasonic examination, according to a Battelle report on the testing of flash-butt-welded chain samples of oil-rig quality, revealed instances in which distinct indications were obtained during ultrasonic examination, but confirmation of the presence of weld defects by sectioning the welds could not be obtained.

It was noted that Lloyds Register does examine the test links of welded chain by ultrasonic methods using an angle-beam transducer sited at the shoulder of the link.

Considering the welded link and the transversely oriented type of defect that might be present, it is thought that a transmission scanning system could be used with transmitting and receiving transducers, which could be ganged together to simplify the inspection technique. A suitable procedure and calibration standard would need to be developed for such a method.

Magnetic-particle examination, using an application standard such as Mil. Std. 271, would enable the surface of the link to be examined effectively.

Bearing in mind the surface condition of the link, indications as small as 1/16 in. could be detected with certainty and their length and orientation determined.

The orientation aspect of surface indications is of importance since this will greatly influence the significance of defects with respect to service failure. For anchor chain, defects with an oblique or transverse orientation to the major axis of the link would be more harmful than those aligned in the axial direction.

The procedures are well established and relatively easy to apply. Since the material would probably have a fair degree of hardenability, precautions against arcing at the contacts should be taken.

Since the stud is conventionally pressed into place against the flash-butt weld, part of the weld circumference on the inside of the link is masked by the stud, and its surface cannot be examined. Although their incidence is probably very low, defects have been reported in this region.

Liquid-penetrant examination systems, including those using fluorescent dyes, produce results similar to those of the magnetic-particle examination methods but will show only those indications that are open to the surface. In this respect they are sometimes useful in giving more information on indications found by the magnetic-particle method.

Chapter 5

FAILURE MODES

INTRODUCTION

Failures in lifting equipment are usually caused by corrosion, wear, stretching, ductile fracture, fatigue, or brittle fracture (Jamieson and Wright, 1975). Any of these mechanisms or a combination of two or more of them may cause parts to fail. For instance, a chain may stretch enough to become unserviceable as a result of high loads and the combined effects of corrosion and abrasion in reducing the cross-sectional area of chain links. Similarly, initiation and growth of fatigue cracks may lead to ductile fracture or to brittle fracture by impact loads.

Equipment failures are sometimes attributed to improper design of components, poorly selected materials of construction, and inadequate manufacturing or testing practices. However, it is generally believed that most failures in lifting chains result from unexpectedly severe operating conditions. Overloading is a common practice that leads to stretching or to ductile, brittle, or fatigue fractures.

Periodic inspections and tests of anchor chain at suitable intervals, as required by the U.S. Navy, are desirable. Such tests can detect stretching, excessive wear from corrosion and abrasion, and the presence of cracks. Conditions leading to brittle fracture are more insidious—they are not usually detected by inspections at regular intervals.

FAILURES IN MOORING SYSTEMS

The systems used for anchoring and mooring ships consist of three subsystems: anchor, chain and accessory fittings (swivels, etc.), and the windlass. The anchor chain consists of shots (90-ft. lengths) of common links permanently joined during manufacture and detachable links used to connect shots made up of common links. The latter category is usually considered to include other types of fasteners or accessories, such as shackles, clevises, and swivels, which couple the ends of the chain to the anchor and to the chain locker. That assignment to the category of detachable or connecting links is used partly because some field service reports identify failed components in an ambiguous manner.

NAVY EXPERIENCE WITH FORGED CHAIN

A NAVSHIPS report dated July 1, 1957, analyzed reports on ground-tackle failures during the preceding 3-1/2 year period (Brown and

Landers, 1957). The 69 failures reported by the fleet correspond to an average of 1 failure/50 ship-years of service. Mooring systems for LST-type vessels accounted for one fourth of the failures; seven occurred in cable, not in anchor chain. Table 1 summarizes the parts failures and their causes.

Fewer than half of the failures in ground tackle, 32 of 69 (46 percent), were failures in chain links. The distribution of failures by type of link was said to be:

Common links	12	Other types	4
Detachable links	11	Unknown	5

Considering that there are far more common (die lock) links in an anchor chain than detachable links, the latter type is far more likely to fail. The report also pointed out that 10 of the 32 link failures occurred in 1-1/4 in. chain used for LST (4 failures), DD (5), and DM (1) type ships. The investigators concluded that the possible advantages of using heavier anchor chains on such vessels and of improving the performance of detachable links should be considered.

To assist this committee, the Naval Sea Systems Command made a search of computerized Navy casualty reports for the period January 1, 1971 through October 30, 1979 (CASREPT, 1979). The number of ship-years of service during that period is not known to the writer. The reports give brief accounts of mooring-system failures in vessels of all types and sizes. Although some U.S. Navy ships are equipped with welded chain, it is generally believed that a very high percentage of the systems consists of forged (die lock-type) common links. Casualty reports are submitted when mooring-system failures degrade a ship's capability to perform one or more of its primary missions. Some of the deficiencies were found during routine inspection and testing.

Table 2 summarizes the information in the casualty reports about the subsystems involved. Broken, bent, and cracked anchors were the most common cause of mooring failures—44 of 200 incidents. Accessories used for connections (shackles, swivels, etc.) were the next most common cause of trouble—21 percent or 43 incidents. Some of those accessories might be considered assignable to the anchor or the windlass subsystem, but the report descriptions were too brief to permit such distinctions. Common links, which make up about 95 percent of the anchor chain (by length) caused about 17 percent of the failures in mooring systems. Detachable connecting links accounted for about half as many failures as common links, even though they are only about 1/25th as numerous. If the figure for connecting links (18) is adjusted to include failures in other connecting components (43), as seems to be normal practice, connections account for 30 percent of the reported failures. Troubles with windlass and hawsepipe assemblies account for about 17 percent of the total failures reported.

TABLE 1 Failures and causes of failures in Parts of Mooring Systems in all Navy Vessels During January 1954 Through June 1957

CAUSE OF FAILURE	PART THAT FAILED												TOTAL	
	Unknown	Chain	Wire Cable	Cable Socket	Shank	Fluke	Shackle	Shackle Pin	Swivel	Stock	Jews Harp	Breakband (Windlass)		Shoulder
Material Failure (No contributing cause)														
Broken		7	1	1	4	2	2	1		1	2	1	1	23
Bent		1			1									2
Bent and Cracked										1				1
Cracked		1												1
Corrosion									1					1
Other	1	3												4
Material Failure (Contributing cause)														
Windlass		3												3
Heavy seas	1	10	5		2									18
Anchor caught	1	5	1		1									8
Hard sand or rock bottom	1						1						1	3
Improper mooring		1												1
Ice								1						1
Other		1												1
No Material Failure	2													2
TOTAL	6	32	7	1	8	3	3	1	1	2	2	1	2	69

TABLE 2 Failures in Mooring Systems, by Categories, Listed in Navy Casualty Reports January 1, 1971 Through October 30, 1979

Category or Subsystem	Failures		Failures (adjusted) ^a	
	Number	Percent	Number	Percent
Anchors	44	22.0	44	22.0
Common chain links	35	17.5	35	17.5
Connecting links	18	9.0	61	30.5
Windlass, bitter end	21	10.5	21	10.5
<u>Accessories</u>				
Shackles, harps	23	11.5	-	-
Swivels	15	7.5	-	-
Ball guides, clevises	5	2.5	-	-
<u>Other</u>				
Abandoned anchors	6	3.0	6	3.0
Stuck in Hawsepipe	13	6.5	13	6.5
Wire cable	8	4.0	8	4.0
Undescribed	12	6.0	12	6.0

^aThe adjustment consisted of adding the 43 failures of accessories to the connecting-link category, as seems to be the practice of the American Bureau of Shipping. Some of them might be just as logically assigned to windlass and anchor failures (From CASREPT, 1979).

The right hand column in Table 2 indicates that 48 percent of the failures in the mooring system are assignable commonly to chain and connecting links. That figure approximates the 46 percent failure rate assigned to chain links in the earlier Navy report (Brown and Landers, 1957).

Some casualty reports included brief judgments, based on visual examinations, about the chain-link failures. Those opinions are summarized in Table 3. Chain links judged unserviceable because of stretching or normal wear from abrasion and corrosion were almost always detected during inspection and testing. For that reason about 40 percent of the incidents (23 of 53) should not be considered service failures. Cracks were found in the studs of two chain links, and two failures were attributed to improperly assembled connecting links. Three failures were attributed to fatigue (without laboratory studies) and three to internal corrosion of the links. Presumably the term internal corrosion referred to attack along the crevices of the mechanical joint between the two parts forming a forged link. Unfortunately, no descriptions were provided about the other 20 (38 percent) links. Since those links were only described as broken, their failures were probably ductile or brittle fractures or both.

COMMERCIAL EXPERIENCE WITH WELDED CHAIN

Stern and Wheatcroft (1978) analyzed information received by the American Bureau of Shipping (ABS) on failures of mooring systems during 1965-68 and 1973-77. Their findings were based on a computerized search of equipment-failure information submitted by surveyors. Like the Navy records described above, the survey records included brief notes identifying failed components but not the results of laboratory studies to determine causes of failures. Presumably, almost all anchor chains had welded links; other ABS data (provided by B.L. Alia) indicate that large welded links perform reliably.

Table 4 shows that the incidence of mooring-system failures of merchant ships is relatively low. Even for the 1973-77 period, when more complete data were being compiled, the failure rate was estimated to be 1 in 200 ship-years' service. That rate is approximately one fourth that mentioned in the 1957 Navy report (CASREPT, 1957). The tabulation also shows that failures in common chain links (96) and of connecting links and shackles (178) accounted for approximately 60 percent of the mooring-equipment failures reported. Connecting components failed almost twice as frequently as common links. After considering the relative number of connecting links and of common links in use, the authors pointed out that the failure frequency of joining components is of the order of 50 times that for common links.

TABLE 3 Summary of Notes Concerning Reasons for Replacement of Forged Chain Links

FAILURE	COMMON LINKS	CONNECTING LINKS	TOTAL
Normal Wear	14	-	14
Stretched	4	5	9
Internal corrosion	2	1	3
Fatigue suspected	2	1	3
Crack in stud	2	-	2
Loose assembly	-	2	2
Broken, undescribed	11	9	20
	35	18	53
TOTAL	35	18	53

From CASREPT, 1979.

TABLE 4 Failures in Mooring Equipment of Merchant Ships (Welded Chain)

Component	1965-1968		1973-1977		Total	
	Number	Percent	Number	Percent	Number	Percent
Connecting links ^a	35	38	143	40	178 ^b	40
Common chain links	21	23	75	21	96	21
Windlass and bitter end ^c	16	18	66	18	82	18
Anchor	19	21	75	21	94	21
Total	91		359		450	
Approximate Number of ship-years	25,000		70,000		95,000	

^aThis category includes some failures of anchor shackles (rings). One failure of a connecting link and one failure of a common link were associated with drilling rigs, not ships.

^bA total of 67 of these failures were reported as anchor-shackle failures, but the reports showed that many of them occurred in the first link joining the shackle.

^cMost windlass failures were caused by windlass malfunctions or operator errors. From Stern and Wheatcroft, 1978.

Table 5 shows that the ABS and Navy records are in remarkably good agreement about the relative frequency of failure of different subsystems of mooring systems. For both types of service, and despite characteristic differences in chain-manufacturing processes, chain defects and failures account for about 60 percent of all defects and failures reported. The Navy and ABS data also indicate that approximately two thirds of those defects and failures occurred in connecting links and accessories.

In an effort to explain the higher failure rates of connecting components, Stern and Wheatcroft (1978) made the following comments:

1. The complex design of connecting links, compared with that of common links, causes larger stress concentrations. Those factors complicate stress analysis and inspection and decrease resistance to dynamic loading.
2. Connecting links and anchor shackles are subject to higher impact loads than the rest of the chain.
3. Anchor shackles do not have to meet specific requirements other than a proof test at a load less than the proof load for chain.

Table 6 summarizes the results of similar surveys made in other countries; presumably most of those merchant ships used welded anchor chain. The Japanese data are for ships of all sizes built since 1968 and in service from 1973 to 1977 (Japanese Association for Prevention of Sea Casualties, 1976). That survey indicated a lower ratio (0.3 to 1) of failure in common links (4) to failures in accessories (15) than those based on American experience (0.5 and 0.6). The data collected by Lloyd's Register are for ships over 800 ft. long built since 1965 and for service from 1969 to the middle of 1978 (Buckle, 1980). Buckle found that failures of mooring systems of large ships were associated mainly with windlass components (119 cases) and windlass prime movers (35). The windlass subsystem accounted for 62 percent of system failures even after 119 lost anchors were excluded from consideration. Unlike the earlier studies, the Lloyd's Register data for large ships show that common chain links failed more often (18 cases) than shackles (8 cases). That ratio of failures in common links to accessories is 2.3 to 1, compared with ratios ranging around 0.5 to 1 in the other surveys. Buckle points out that small variations in the relative strengths of links and shackles would be expected to have a pronounced effect on the relative frequency of failures in the two types of chain components. That is, improving the strength of shackles or of common links might not have a noticeable effect on total failure rates of mooring systems. Buckle also found that failure rates of anchor chain have not increased with ship size; for those classified by Lloyd's Register, failure rates of mooring systems amount to about 1 per 60 years of ship service.

TABLE 5 Mooring Equipment Defects and Failures in Navy and ABS Records, by Subsystem Involved^a

Subsystem	Number		%	
	ABS	Navy	ABS	Navy ^b
Anchors	94	57	21	27
Connecting links and accessories	178	79	40	38
Common links	96 ^c	47 ^d	21 ^c	23 ^d
Windlass and bitter ends	82	24	18	12
Total	450	207 ^b	100	100

^aFrom Tables 1, 2, and 4.

^bThe exclusions from data in Table 1 are those for 8 wire cable systems, 9 unclassifiable links, and 6 unknown components. The 39 failures listed as Other in Table 2 were also excluded.

^cPredominantly welded chain links in ABS anchor chain.

^dPredominantly forged chain links in Navy anchor chain.

TABLE 6 Losses of Cables and Other Failures on Japanese Ships^a and Ship Losses in World Shipping^b

Data Studied	Source	
	Buckle	Japanese Assoc.
Ships at risk	61,000	952 ^a
Survey period	1964-1978	1973-1977
Ship-years' service	-	3,294
Cables lost overboard	-	13 ^c
Broken shackles	-	15
Broken common links	-	4
Causes of Ship Losses		
Dragging anchors	38	-
Broken cables	4	-
Broken mooring	19	-
Broken towlines	27	-
Other causes	3	-

^aJapanese ships of all lengths built since 1968.

^bLosses in world shipping derived from Lloyd's Casualty Reports of ships over 100 gross tonne; six losses for ships over 20,000 gross tonne.

^cCable losses were mainly from failure of windlass brakes. From Japanese Association for the Prevention of Sea Casualties, 1976; and Buckle, 1980.

CAUSES OF FAILURES IN ANCHOR CHAIN

Periodic inspection by the Navy is designed to remove suspect or defective links from service before incidents in usage occur.

Forged Links for Anchor Chain

Most of the available information on the causes of failure in anchor chain is of a general nature. Very few reports on laboratory failure analyses were uncovered by the committee.

The data for forged chain links used by the U.S. Navy are summarized in Table 3 (CASREPT, 1979). They indicate that 23 of the 33 diagnosed failures were attributed to stretching and to normal wear, including general corrosion. Fatigue was suspected of causing three other failures, but no supporting data were available. Fatigue is not considered to be a likely cause of failure because anchor chains are not subjected to a large number of cyclic loads. The committee was informed that the CVAN 69 dropped and retrieved its anchor only 20 times in 1979. Furthermore, the practice of proof-loading chain to two thirds of its breaking strength could increase its failure strength compared with that of the original stock (Celander, 1972).

Table 3 attributes three failures of anchor chain to internal corrosion. Presumably that mode of failure occurs only with chain links made by swaging to assemble two forged components and would not be encountered in welded chain.

Table 3 indicates that the other 20 failures, excluding four attributed to cracked studs and loose assemblies, apparently resulted from ductile or brittle fracture. Like stretching (9 cases), the incidence of ductile fracture would be expected to depend on the incidence of overloading and on the strength of the links. The best precaution for minimizing brittle fracture is the assurance that chain components have reasonably high tensile elongation and V-notch Charpy values. Both factors are related to the microstructure of the steel, a characteristic of its composition and manufacture. The surveys indicate that the specifications have been adequate for procuring reliable forged anchor chain. Similarly, it would be expected that welded anchor chain meeting similar specifications and made under carefully controlled conditions would also perform satisfactorily.

Welded Chain

Most of the available information on failures in welded links is concerned with chain produced by flash-butt-welding procedures and used on merchant ships and offshore rigs. It is generally believed that flash-butt-welding can produce joints of very high

quality (American Society for Metals, 1971). The preheating, high-temperature heating, and upsetting operations are performed in equipment provided with automatic sequencing. Since no filler metal is added, the joints can develop properties equal to those of the raw material. The flashing and upsetting operation expels material, mainly slag and other molten material, at the joint. Another advantage of flash-butt-welding is that important welding parameters can be preset and then monitored to assure reproducible manufacturing practices. For those reasons, flash-welded joints are usually more reliable than those made by other welding processes. For instance, the failure rates of joints in continuous railway rails are said to be as follows (Hauser, 1978):

<u>Type of Joint</u>	<u>Failure Rate (per 10,000 weld-years' service)</u>
Flash-welded	0.435
Gas-pressure-welded	13.34
Thermit-welded	36.8

Because flash welding can produce high-integrity joints reproducibly, it is widely used for joining high-strength steel parts for aircraft landing gear. Postweld heat treatments can develop joints as strong as the base metal, 200,000 psi for 4130 steel or 240,000 psi for 4340 steel. Heat-treatable steels are usually normalized or quenched and tempered after welding to ensure attainment of uniform properties.

The most common types of defects in flash-butt welds and their most likely causes are (American Society for Metals, 1971):

- Circumferential crevices—Insufficient heating or upsetting
- Cracks in heat-affected zone—Fast cooling
- Voids or cast metal at joint—Insufficient pressure or
upsetting
- Oxides, inclusions, decarburization—Improper platen speed,
voltage, or flashing gap
- Intergranular burning—Inadequate contact between electrodes
and workpiece

In repetitive operations, it should be relatively easy to prevent such defects.

Experience of ships using flash-butt-welded chain appears to be good. The Royal Navy (England) uses welded anchor chain almost exclusively and has had very few problems in service. According to information presented at an informal meeting in 1979 at Lloyd's Register of Shipping, experience with flash-butt-welded chain, particularly in the larger sizes, has been good (private communication). The people from Lloyd's technical staff and the Technical Records Office indicate that welding practices

are important and must be carefully monitored.

Data collected by the American Bureau of Shipping also indicate that welded anchor chain performs satisfactorily. That organization estimates that about 700 ships are using anchor chain with links 4 in. or larger in diameter, probably all of which is welded; of those, approximately 300 ships are classified by ABS. A search by ABS of its technical files for failures in chain with links larger than 4 in. in classified ships during 1973-77 disclosed only three cases of damage or failure.

The three failures of welded anchor chain reported to the ABS were described as:

1. Stretching and cracking of the fourth inboard link and the fifth inboard link while the ship was anchored in heavy weather.
2. Seven bent links in another anchor chain; the reports did not mention failure.
3. One failure by cracking originating near the radius of a stud and adjacent to one of the flash welds joining the integral stud to the link. (This represents an unusual type of link.)

Failures indicated as types 1. and 2. are like some mentioned in Table 3 and can be expected from either welded or forged chain with strengths too low for severe operating conditions.

Stern and Wheatcroft (1978) concluded that some of the causes for failures encountered in common and connecting links are:

- Brittle fracture because of low operating temperatures or improper heat treatment.
- Degraded properties as a result of poor manufacturing practices.
- Cracks associated with tack welding of studs.
- Lack of fusion, and microcracks in the heat-affected zone of welded chain.
- Internal unsoundness.
- Improper operation of equipment.

Welded Chain—Laboratory Studies

Laboratory studies were conducted by Lloyd's on links from welded anchor chains considered to be unsatisfactory by their owners (private communication). The compositions and other characteristics of sound and defective chain links are listed in Table 7. Some of the other findings are summarized below because they indicate potential causes of trouble with flash-butt-welded anchor chains.

TABLE 7 Data From Laboratory Studies on Welded Anchor Chain

Chain	Sample Designation and Type ^a						
	009, F	009, S	009, F	009, S2	0113/2	0123, F	
<u>Composition (%)</u>							
C	0.21	0.21	0.21	0.22	0.18	0.21	
Mn	1.84	1.84	17.3	1.74	1.87	1.93	
Si	0.42	0.42	0.42	0.42	0.34	0.36	
Ni	0.20	0.20	0.09	0.09	0.14	0.12	
Cr	0.31	0.31	0.19	0.20	0.16	0.15	
Cu	0.16	0.16	0.10	0.10	0.27	0.23	
V	0.06	0.06	0.07	0.07	0.09	0.09	
Mo	0.04	0.04	0.03	0.03	0.04	0.02	
<u>Properties</u>							
							
Tensile strength, psi	118,500	91,000	105,300	104,400	108,000	110,000	114,000
0.2% yield, psi	73,000	63,600	74,100	73,400	60,500	61,000	71,000
Elongation (%)	13.0	22.0	21.0	21.0	13.0	20.0	20.0
Charpy at 32°F (0°C) (ft-lb)	11	40	95	100	38	21	25
Shear texture (%)	40	40	40	40	35	35	30

^aF, data for specimen from failed links; S, data from a sound link. Data obtained on a personal visit to Lloyd's Register of Shipping

1. A 2-3/8 in.-diameter link failed through the center of a 0.4 in.-deep indentation in the link caused by deforming the link to meet the stud. The strain associated with the indentation caused a crack, up to 0.9 in.-deep, to form in the heat-affected zone (HAZ) of the butt weld in the link immediately above the stud. That crack, which occurred before heat treatment, grew in service until brittle fracture took place.

2. Two links in a 3-1/4 in. chain broke in a brittle manner. In both cases the fractures occurred at two positions—in the vicinity of the flash-butt weld and transversely at the opposite sides of both links. The fractures near the butt weld took place in the HAZ during manufacturing, and that area exhibited a coarse-grained, microstructure with a ferrite network. Those characteristics, and crack initiation, resulted from gross overheating during welding. A sound link from the chain showed no evidence of grain coarsening. The properties of the sound and failed links are those listed for Samples 0009 in Table 7.

The sound links, with a uniformly fine-grained structure, had acceptable mechanical properties. However, specimens from the two failed links gave test values below the required levels of 17 percent elongation in tension and 43 ft.-lb. in V-notch Charpy tests at 32°F (0°C). The parent metal of those links was fine-grained, but one exhibited a partially hardened structure containing bainite. The latter characteristic was considered responsible for the poor mechanical properties. Renormalizing did not eliminate the bainite or improve the Charpy properties, but a subsequent tempering treatment was beneficial. Later studies on other links indicated that normalizing and tempering did not improve the properties of across-the-weld specimens.

3. Three separate 3-1/4 in. chain links that had been rejected for service after magnetic-particle inspection were also examined. The study showed that inadequate gripping of the bars during flash welding produced folds or laps on the surface of the bars. Specimens taken from the base metal of the links, Sample 0113 in Table 7, had satisfactory tensile properties but unusually poor Charpy values. The across-the-weld specimen had poor tensile ductility. The lack of notch toughness was attributed to the high manganese content of the steel, which caused bainite to form in segregated areas. This experience confirms the opinion that tempering after normalizing is desirable.

4. Another 3-1/4 in. diameter chain link, for a drilling rig, with defects on both sides of the flash-butt weld, was also examined (Sample 0123 in Table 7). The Charpy properties of the parent metal on the side opposite the weld were poor. That deficiency was attributed to the presence of patches of bainite in the microstructures resulting from a high manganese content.

Doerschuk, et al. (1977) evaluated the properties of some samples of 4-3/4 in. flash-welded alloy steel stud-link chain. The commercial producers of the four samples were not required to follow the technical guidelines of the interim specification available at that time, but their manufacturing practices were judged to be in close accord with those guidelines.

Table 8 lists the steel composition of the samples from flash-welded anchor chain. Samples A and C meet the chemistry limits for standard AISI 1330 steel. Samples B and D contain vanadium and have carbon levels too low for that standard grade.

All of the samples met the bend test described in MIL-C-24573. None of the chain specimens broke in or near the flash weld. The results of other tests on samples taken from the chain are summarized in Table 9. Comparing those values with the ones required by the current MIL specification leads to the following comments:

- Sample C - slightly oversized but met all other requirements.
- Sample B - gave a breaking load 3.7 percent below required level but met other requirements.
- Sample A - slightly undersized, narrowly failed breaking-load and yield-strength requirements; met other requirements.
- Sample D - failed to meet required yield-strength and Charpy value for specimens taken near weld; met other requirements.

Since chain samples A and D had yield strengths below the required level of 68,000 psi, it may be well to remember that Board of Trade rules specify a minimum ultimate strength, not a minimum yield strength (Celander, 1972).

The investigators also conducted metallographic studies on samples taken from the chain. They found that the fillet weld between the stud and link of Sample C was of poor quality; poor bead contour, cracks, and regions of lack of fusion were detected. Some small cracks were found in Sample D near the flash weld and adjacent to the pressed-in stud. (This defect apparently resembles one of those found in laboratory studies by Lloyd's Register and described above.) Some bainite was present in banded (segregated) areas of Sample B. The microstructure of Sample C indicated that it had been quenched and tempered, not normalized as required by the current specification.

The investigators concluded that flash-welded 4-3/4 in. anchor chain can be manufactured by existing commercial interests in accordance with the interim specification (Doerschuk, et al., 1977).

TABLE 8 Composition of Steel in Samples of 4-3/4 In. Flash-Butt-Welded Anchor Chain

Sample Designation	Chain Grade	Chemical Composition (%)								
		C	Mn	Si	Ni	Cr	Cu	V	P	S
A	Oil-rig quality	0.34	1.72	0.21	0.04	0.04	0.01	0.006	0.03	0.02
B	Extra-high-strength Grade 3	0.22	1.83	0.22	0.12	0.09	0.09	0.061	0.01	0.04
C	Extra-high-strength Grade 4	0.33	1.81	0.27	0.04	0.03	0.03	0.005	0.03	0.02
D	Oil-rig quality	0.24	1.59	0.31	0.13	0.17	0.21	0.091	0.02	0.03

From Doerschuk, et al., 1977

TABLE 9 Data From Tests on Triplets of 4-3/4 In. Flash-Welded Alloy Steel Chain

Chain Specifications	Sample Designation and Diameter; in.(mm)			
	A, 4.73(120.0)	B, 4.75(120.5)	C, 5.2(132.0)	D, 4.73(120.0)
Proof load, million lb.	1.7	1.7	1.7	1.7
Stretch (%)	0.00	2.01	0.23	0.39
Breaking load, million lb.	2.540 ^a	2.455 ^a	3.110	2.570
Tensile properties				
Ultimate strength, psi	100,800	94,300	102,000	92,300
0.2% yield strength, psi	67,700	69,500	70,600	61,200
Reduction in area (%)	66.1	68.8	64.6	70.0
Brinell hardness				
At mid-radius	199	192	201	185
0.1" below surface	187	181	269	188
Charpy V-notch at 32°F (0°C)				
Near weld (ft-lb) ^b	45	52	65	26 ^d
Base metal (ft-lb) ^c	53	122	107	127
Shear area				
Near weld (%) ^b	50	57	62	44
Base metal (%) ^c	45	90	81	91

^aMIL-C-24573(Ship) specifies a minimum breaking load of 2,550,000 lb.

^bAverages for two specimens.

^cAverages for three specimens.

^dThis value is below the minimum value of 36 ft-lb specified in MIL-C-24573(Ship). The individual values were 14.5 and 37 ft-lb.

From Doerschuk, et al., 1977.

REFERENCES

- American Society for Metals. 1971. "Flash and Fraction Welding." In Metals Handbook, Vol. 6, 8th Ed., pp. 485-518.
- Brown, P. and R. Landers. 1957. NAVSHIPS Report No. 373-12(981), (July 1).
- Buckle, A.K. 1980. "Ten Year Review of Defects and Failures in Large Ships' Anchoring and Mooring Equipment." Preprint C46 for Conference on Mooring Large Ships Over 150,000 dwt, London, December 5, 1979. Accepted for publication in Marine Eng. (C), Vol. 92.
- CASREPT Data Retrieval EIR TM03 NAVSEA 5141. 1979. In three parts: 710101 to 741231 (50 pp.); 750101 to 751231 (22 pp.); 760101 to 791024 (62 pp.). U.S. Navy Ships Parts Control Center, Mechanicsburg, Pa., (October 30).
- Celander, I. 1972. "Preload Influence on Fatigue Characteristics of Chain Cable Exposed to Salt Weather and Atmosphere Conditions." Presented at Offshore Technology Conference, paper OTC 1578.
- Doerschuk, D.C., R.J. Eiber, and T.P. Groeneveld. 1977. "Laboratory Evaluation of 4-3/4" Flash Welded Alloy Steel Stud Link Anchor Chain." Final report on MIPR No. N002476 MP6626M, 60 pp., (August).
- Jamieson, F.L. and R.A. Wright. 1975. "Failures in Lifting Equipment," In Metals Handbook, Vol. 10, 8th Ed., American Society for Metals, pp. 455-467.
- Japanese Association for Prevention of Sea Casualties. 1976. "Investigation into Anchoring of Large Ships." (Not seen; cited in Buckle, 1980.)
- Hauser, D. 1978. "Welding of Railroad Rails—A Literature and Industry Survey." In Special Technical Publication 644. American Society for Testing and Materials, Philadelphia, Pa.
- Military Specification MIL-C-24573(Ship). 1978. "Chain, 4-3/4 Inch Stud Link, Anchor, Steel, Flash Butt Welded," (May 15).
- Stern, I.L. and M.F. Wheatcroft. 1978. "Toward Improving the Reliability of Anchor Chain and Accessories." Presented at 10th Offshore Technology Conference, Houston, Texas. Paper number 3206, (July).

Chapter 6

DIE LOCK- AND FLASH-WELDED CHAIN EXPERIENCE

ANALYSIS PROCEDURE

The records and statements of operators described below for experience with die lock and flash-welded chain were reviewed and classified to determine recognizable patterns and feelings of satisfaction or dissatisfaction on the part of commercial and Navy ship operating personnel. The design of chain links, wildcats, and storage systems was also reviewed. An analysis was made, and conclusions were drawn from the results of these reviews.

U.S. NAVY DIE LOCK CHAIN SERVICE EXPERIENCE

Aircraft-Carrier Casualties

Records before 1971 are not available or are not completely reliable. The casualty reporting (CASREPT) data from the Navy for the period 1971-79 (CASREPT, 1979) appear substantially complete and reliable. CASREPT data for aircraft carriers (1971-79) were examined first and are summarized in Table 10. Two end-connecting links were found to be cracked, presumably during a routine examination. There was no loss of other ground tackle. There was one instance of loss of anchor and 180 fathoms of chain, "cause unknown." This casualty is typical of either operator error or failure of the wildcat braking system. There was one instance of loss of anchor and 15 fathoms of chain because of a failure of a detachable link. There were three failures of anchor flukes under heavy strain.

There were no cases reported of failure of a die lock chain link.

Medium-Ship Ground-Tackle Casualties

Review was made of the 1971-79 CASREPT data for medium ships. In two ships under routine inspection, cracked or bent anchor or anchor-bending shackles were found. There were four cases of lost (later recovered) anchors and chains that occurred during the severe drop tests routinely conducted by the Navy Board of Inspection and Survey. In all four cases, the casualty resulted from failure of the wildcat brake. In one case, the anchor shank was broken when the anchor dragged in high seas. The details are given in Table 11.

There were no cases reported of failure of a die lock chain link.

TABLE 10 Defects and Failures of Ground Tackle in Aircraft Carriers,
U.S. Navy, 1971-79

Date	Ship	Casualties
5-12-73	USS Kennedy CV 67	Cracked end link—anchor shackle to chain—cause unknown.
5-22-73	USS Kennedy CV 67	Cracked end-connecting link—anchor shackle to chain—cause unknown.
6-02-73	USS Kennedy CV 67	Lost anchor and 180 fathoms of chain in Cannes Harbor—cause unknown (probably operator error or wildcat brake).
4-06-75	USS Roosevelt Cv 42	Lost port anchor, 40,000-lb anchor, swivel shot, and 15 fathoms of 3-1/2 in. chain—cause, failure of detachable link at 15-fathom marker.
4-22-75	USS Forrestal CV 59	Broken fluke, starboard anchor.
2-27-75	USS Saratoga CV 60	Broken flukes on port anchor under anchor-dragging conditions.
5-16-79	USS Midway CV 41	Broken fluke, believed to have occurred when heavy strain taken while setting anchor.

From CASREPT, 1979

TABLE 11 Defects and Failures of Ground Tackle in Medium Sized Ships, U.S. Navy, 1971-79

Date	Ship	Casualty
5-09-74	USS Detroit AOE 4	Sprung anchor shackle—bent pin.
5-12-76	USS Kilauea AE 26	Lost anchor and 60 fathoms in 70 fathoms water during Insurv trials. Anchor and chain allowed to run free, then wildcat brake applied. Parted connecting shackle.
3-22-79	USS Ashtabula AO 51	Lost anchor and chain during Insurv test. Wildcat brake linings faulty.
5-07-76	USS Kawishiwi AO 146	Lost anchor and chain during drop test. Wildcat brake failed.
3-29-77	USS Ponchatoula AO 148	Lost anchor and chain during anchor wildcat test by Insurv. Brake failure. Chain ran free.
1-28-79	USS Seattle AOE 3	Anchor sank broken near crown, caused by dragging anchor in heavy seas during recovery to get underway to prevent grounding.
7-14-77	USS Detroit AOE 4	Cracked bending link to anchor; one shot found during overhaul not to meet specifications.

From CASREPT, 1979.

Destroyer Ground-Tackle Casualties

An analysis was next made of the ground-tackle casualties reported for destroyers. A chart classifying all destroyer casualties during the period 1971-79 is given as Table 12. There were eleven CASREPT documents reporting ground tackle out of specification during routine overhaul examinations. There were seven failures of detachable links and seven failures of anchors (mostly under heavy load).

There were no cases reported of failure of a die lock chain link.

TABLE 12 Types of Failure of Common Link in Destroyers, U.S. Navy 1971-79

Out of Specification	Detachables Link	Anchor
DDG 4	DDG 35	DDG 8
DDG 5	DD 742	DDG 40
DDG 32	DD 847	DD 868
DD 708	DD 864	DD 880
DD 776	DD 878	DD 940
DD 805	DD 944	DD 883
DD 819	DD 945	DD 950
DD 820		
DD 763		
DD 785		
DD 863		
Total 11	7	7

From CASREPT, 1979

FLASH-WELDED CHAIN EXPERIENCE

Flash-welded chain service data were not available in a CASREPT form. An October 29, 1979, American Bureau of Shipping report gives a summary of failure data collected from survey reports for 1965-68 and 1973-79. Table 13 shows the results of these reports. It is apparent that failure of connecting links dominated the casualty reports. Fifty percent of all failures (excluding anchor failures) were connecting-link failures. Twenty-seven percent were common-link failures. In the ABS documents, the chief surveyor reported that during the period 1973-77, three big (larger than 4 in.) chain failures were observed. One failure occurred in the radius of an integral stud (near the heat affected zone of the flash weld); another failure occurred at the

fifth link inboard while the ship was at anchor in heavy weather; another link was elongated and cracked, indicating significant stressing. In another case, the chain suffered seven bent links with no mention of cracking.

TABLE 13 Number of Ground-Tackle Failures Reported in Merchant Ships, 1965-77, by Type of Equipment

Anchor	Connecting Link	Common Link	Bitter End ^a
94	178	96	82

^aMost bitter-end failures were related to windlass malfunction or to operator error.

From American Bureau of Shipping, October 29, 1979.

A review of the experience of operating personnel did not provide crisp and definitive information. Few people had experience with both die lock and flash-welded chain. All confirmed the urgent necessity for reliable ground tackle.

Design considerations include not only strength and resistance to failure of the chain links, but also resistance to strain. Elongation and distortion of the links beyond specification result in poor fit of the links in the whelps of the wildcat. With the chain out of the control of the wildcat, loss of ground tackle and even disaster can occur. A comparison of the dimensions of the chain as shown in the U.S. manufacturer's catalog is presented in Table 14. From the above table it can be seen that the lengths and widths of the individual chain links are identical and that the weights of the 15-fathom shots are essentially the same, and therefore, the use of such welded chain should be compatible with existing wildcats and associated systems. There is also a design parameter relating to stacking and payout without kinking; this is important in preventing overstressing and material damage and loss. The stud is obviously the key in the prevention of kinking. The size and shape of the holes are also important.

The review of service experience available would indicate that the die lock chain has been satisfactory and reliable in naval service, and that there has been little U.S. Navy experience with welded chain.

TABLE 14 Comparison of the Dimensions of 3-3/4 In. Chain

Dimension	Die Lock Chain	Standard Welded Chain	Oil-Rig-Quality Welded Chain
Link length (in.)	22-1/2	22-1/2	22-1/2
Link width (in.)	13-3/8	13-3/8	13-3/8
Length of five links (in.)	82-1/2	82-1/2	82-1/2
Weight per 15-fathom shot (lb.)	12,500	12,000	12.626

Chapter 7

ECONOMIC ASPECTS

Forged die lock chain is essentially the only chain which has been used for anchor chain by the U.S. Navy. Only one other company, a U.S. company, has made anchor chain using the die lock method and this company currently does not have the capability to make the large 4-3/4 in. size chain either by the die lock process or by the welded process. This company will, however, supply welded chain of the 4-3/4 in. size which they obtain from a foreign affiliate. Welded chain also is available from several foreign sources in the 4-3/4 in. and larger sizes.

The U.S. company also has recently expressed an interest in working with the Navy to develop a capability to supply 4-3/4 in. die lock chain required as anchor chain for the aircraft carriers currently under construction or authorized. Significant premium tooling, conversion, and set-up costs would be required for this arrangement. This could be a viable short-term approach but would appear to be a less than satisfactory long-term approach.

Significant cost savings can be realized if commercially available welded chain is substituted for die lock chain. Since price comparisons were not available for the 4-3/4 in. chain, information on 3-3/4 in. chain is presented in Table 15.

The price comparison shows that the price of standard welded chain is approximately 47 percent of that of die lock chain and that the price of oil-rig-quality welded chain is approximately 56 percent of that of the die lock chain. The use of twelve standard 15-fathom shots of chain for each of two anchors per aircraft carrier would result in a significant savings if welded chain were used instead of die lock chain.

TABLE 15 Price Comparisons for 3-3/4 In. Chain

Type of Chain	Proof Test (1b ⁶)	Break Test (1b ⁶)	Price per 15- Fathom Shot
Die Lock (complies with MIL-C-19944)	1,008	1,575	\$72,000 ^a
Standard welded (grade 3)	1,019	1,455	\$33,600 ^b
Oil-rig quality welded	1,120	1,750	\$40,320 ^b

^aPlus \$15,000 set up charge.

^bPlus \$ 3,000 set up charge.

As indicated earlier in Chapter 6 (Table 14) the physical dimensions of the 3-3/4 in. chain are essentially the same for the die lock chain, the standard welded chain, and the oil-rig-quality welded chain.

Although the physical dimensions and price comparisons shown in Tables 14 and 15 are for 3-3/4 in. chain rather than for 4-3/4 in. chain which is the subject of this report, it is reasonable to expect that the comparisons presented are representative of what would be expected for the larger size chain and that significant cost savings are available if welded chain is used instead of die lock chain.

At the present time the large size chain is not manufactured in the U.S. but it is manufactured in several other countries using the welded process. Assuming that all other considerations are satisfactorily met, substitution of welded chain commercially available from several world sources would be the most economical approach for future procurements of anchor chain.