



## Buildings: Fire Safety Aspects of Polymeric Materials, Volume 7 (1979)

Pages  
232

Size  
5 x 8

ISBN  
0309363527

Committee on Fire Safety Aspects of Polymeric Materials; National Materials Advisory Board; Commission on Sociotechnical Systems; National Research Council

 [Find Similar Titles](#)

 [More Information](#)

### Visit the National Academies Press online and register for...

- ✓ Instant access to free PDF downloads of titles from the
  - NATIONAL ACADEMY OF SCIENCES
  - NATIONAL ACADEMY OF ENGINEERING
  - INSTITUTE OF MEDICINE
  - NATIONAL RESEARCH COUNCIL
- ✓ 10% off print titles
- ✓ Custom notification of new releases in your field of interest
- ✓ Special offers and discounts

Distribution, posting, or copying of this PDF is strictly prohibited without written permission of the National Academies Press. Unless otherwise indicated, all materials in this PDF are copyrighted by the National Academy of Sciences.

To request permission to reprint or otherwise distribute portions of this publication contact our Customer Service Department at 800-624-6242.

Copyright © National Academy of Sciences. All rights reserved.







**Fire Safety Aspects  
of  
Polymeric Materials**

**VOLUME 7  
BUILDINGS**

**Report of**

**The Committee on Fire Safety  
Aspects of Polymeric Materials**

**NATIONAL MATERIALS ADVISORY BOARD  
Commission On Sociotechnical Systems  
National Research Council**

**Publication NMAB-318-7  
National Academy of Sciences  
Washington, D.C.  
1979**

**NAS-NAE**

**JUN 03 1981**

**LIBRARY**

TA  
455  
1752N3  
V.7  
C.1  
(79-1920-CT)

**VOLUME 7 – BUILDINGS**  
**Fire Safety Aspects of Polymeric Materials**

©TECHNOMIC Publishing Co., Inc., 1979  
265 Post Road West, Westport, CT 06880

This work may be reproduced in whole or in part for the official use of the  
U.S. Government

Printed in U.S.A.  
Library of Congress Card No. 77-79218  
I.S.B.N. 0-87762-228-0

## NOTICE

The project that is the subject of this report was approved by the Governing Board of the National Research Council, whose members are drawn from the councils of the National Academy of Sciences, the National Academy of Engineering, and the Institute of Medicine. The members of the Committee responsible for the report were chosen for their special competences and with regard for appropriate balance.

This report has been reviewed by a group other than the authors according to procedures approved by a Report Review Committee consisting of members of the National Academy of Sciences, the National Academy of Engineering, and the Institute of Medicine.

This study by the National Materials Advisory Board was conducted under Contract No. 4-35856 with the National Bureau of Standards.

Printed in the United States of America.

## FOREWORD

This volume is one of a series of reports on the fire safety aspects of polymeric materials. The work reported here represents the results of the first in-depth study of this important subject. The investigation was carried out by a committee of distinguished polymer and fire technology scholars appointed by the National Academy of Sciences and operating under the aegis of the National Materials Advisory Board, a unit of the Commission on Sociotechnical Systems of the National Research Council.

Polymers are a large class of materials, most new members of which are man-made. While their versatility is demonstrated daily by their rapidly burgeoning use, there is still much that is not known or not widely understood about their properties. In particular, the burning characteristics of polymers are only now being fully appreciated and the present study is a landmark in the understanding of the fire safety of these ubiquitous materials.

In the first volumes of this series the committee has identified the limits of man's knowledge of the combustibility of the growing number of polymeric materials used commercially, the nature of the by-products of that combustion, and how fire behavior in these systems may be measured and predicted. The later volumes deal with the specific applications of polymeric materials, and in all cases the committee has put forth useful recommendations as to the direction of future actions to make the use of these materials safer for society.

Harvey Brooks, Chairman  
Commission on Sociotechnical Systems

## ABSTRACT

This is the seventh volume in a series. The fire safety aspects of polymeric materials relevant to buildings, including their furnishings, are examined. The great majority of fire deaths occurs in residential buildings. The problems of residential buildings are accordingly emphasized. Consideration is also given to other types of buildings.

Fire characteristics of polymeric materials generally used in building construction and furnishings are reviewed in depth; problem areas are highlighted. Fire test methods for these materials are critically reviewed. Building fire statistics are summarized; the fire scenario technique is discussed and illustrated. The interrelationship between building design factors and choice of materials is treated.

Highlighted problem areas include seating and bedding items containing flexible foam, interior finish materials, structural foam furniture, organic insulation electrical cables, and mobile homes.

Conclusions are drawn in chapters 3 through 6 and recommendations are made. The most general conclusions and recommendations are summarized in chapter 2.

## VOLUMES OF THIS SERIES

- |           |                                                              |
|-----------|--------------------------------------------------------------|
| Volume 1  | Materials: State of the Art                                  |
| Volume 2  | Test Methods, Specifications, Standards                      |
| Volume 3  | Smoke and Toxicity<br>(Combustion Toxicology of Polymers)    |
| Volume 4  | Fire Dynamics and Scenarios                                  |
| Volume 5  | Elements of Polymer Fire Safety and<br>Guide to the Designer |
| Volume 6  | Aircraft: Civil and Military                                 |
| Volume 7  | Buildings                                                    |
| Volume 8  | Land Transportation Vehicles                                 |
| Volume 9  | Ships                                                        |
| Volume 10 | Mines and Bunkers                                            |

## PREFACE

The National Materials Advisory Board (NMAB) of the Commission on Socio-technical Systems, National Research Council, was asked by the Department of Defense Office of Research and Engineering and the National Aeronautics and Space Administration to "initiate a broad survey of fire-suppressant polymeric materials for use in aeronautical and space vehicles, to identify needs and opportunities, assess the state of the art in fire retardant polymers (including available materials, production, costs, data requirements, methods of test and toxicity problems), and describe a comprehensive program of research and development needed to update the technology and accelerate application where advantages will accrue in performance and economy "

In accordance with its usual practice, the NMAB convened representatives of the requesting agencies and other agencies known to be working the field to determine how, in the national interest, the project might best be undertaken. It was quickly learned that wide duplication of interest existed. At the request of other agencies, sponsorship was made available to all government departments and agencies with an interest in fire safety. Concurrently, the scope of the project was broadened to take account of the needs enunciated by the new sponsors as well as those of the original sponsors.

The total list of sponsors of this study now comprises Department of Agriculture, Department of Commerce (National Bureau of Standards), Department of Interior (Division of Mine Safety), Department of Housing and Urban Development, Department of Health, Education and Welfare (National Institute for Occupational Safety and Health), Department of Transportation (Federal Aviation Administration, U.S. Coast Guard), Department of Energy, Consumer Product Safety Commission, Environmental Protection Agency, and Postal Service, as well as the original sponsors.

The committee was originally constituted on November 30, 1972. The membership was expanded to its present status on July 26, 1973. The new scope was established after presentation of reports by liaison representatives covered needs, views of problem areas, current activities, future plans, and relevant resource materials. Tutorial presentations were made at meetings held in the Academy and during site visits, when the committee or its panels met with experts and organizations concerned with fire safety aspects of polymeric materials. These site visits (upwards of a dozen) were an important feature of the committee's search for authentic information. Additional inputs of foreign fire technology were supplied by the U.S. Army Foreign Science and Technology Center and NMAB Staff.

This study in its various aspects is addressed to those who formulate policy and allocate resources. A sufficient data base and bibliography has been supplied to indicate the breadth of this study.

## ACKNOWLEDGMENTS

Panel members of the National Materials Advisory Board Committee on Fire Safety Aspects of Polymeric Materials as well as government liaison representatives drafted this report which was reviewed and finalized by the entire committee. Conclusions and recommendations are the sole responsibility of the committee. Coordination of this volume was performed by Dr. Raymond Friedman, Dr. John M. Butler, Dr. Richard S. Magee, and Mr. Donald G. Smillie.

Other significant inputs were furnished by committee members Dr. Alfred R. Gilbert, Dr. Raymond R. Hindersinn, Dr. Eli M. Pearce, Dr. Arnold Rosenthal and Dr. Giuliana Tesoro. Additional inputs were supplied by liaison representatives, Mr. John Ferguson, National Fire Prevention and Control Administration, U.S. Department of Commerce; Mr. Donald L. Moore, U.S. Department of Housing and Urban Development; and Mr. Jack Ross, U.S. Air Force, Department of Defense.

A number of other people made substantial contributions to this volume. Some were professional colleagues of the committee participants contributed their ideas, advice, and assistance to various portions of the work. Some were official guests of the committee and contributed tutorial presentations; these include Dr. William Werner and Mr. D. L. Moore, U.S. Department of Housing and Urban Development; Mr. Henry Roux, Armstrong Cork Co.; Mr. Leon Moed, Skidmore, Owings, and Merrill; Messrs. Eugene Schafran and Najib Budeiri, Port Authority of New York and New Jersey, Dr. Anne W. Phillips, The Smoke, Fire, and Burn Foundation; Professor Rudyard Jones, University of Illinois; Dr. Herbert Eichner, Forest Products Laboratory, U.S. Department of Agriculture; Mr. I. Benjamin, National Bureau of Standards, U.S. Department of Commerce; Mr. James Smith and Dr. Nelson Grisamore, National Research Council; Mr. Joseph Stein, Tishman Research Corp.; Dr. Gordon Damant, California Flammability Research Laboratory; Mr. B. A. Barnett, Central Dockyard Laboratory, HM Naval Base, Portsmouth; Mr. H. Nelson, U.S. General Services Administration; Dr. J. DeRis and Messrs. P. E. Cotton, J. M. Rhodes, and W. P. Thomas, Factory Mutual Research Corp. The committee wishes to express its appreciation to these people as well as to those who may have been inadvertently omitted from the list.

I acknowledge with gratitude the assistance in this project of Dr. R. S. Shane, NMAB Staff Scientist, and Miss Carolyn A. Tuchis, our able secretary.

Dr. Herman F. Mark,  
Chairman

## NATIONAL MATERIALS ADVISORY BOARD

### Chairman

Mr. Julius J. Harwood  
Director, Materials Science Laboratory  
Engineering and Research Staff  
Ford Motor Company  
P. O. Box 2053  
Dearborn, MI 48121

### Past Chairman:

Dr. Seymour L. Blum  
Vice President  
Northern Energy Corporation  
70 Memorial Drive  
Cambridge, MA 02142

### Members

Dr. George S. Ansell  
Dean, School of Engineering  
Rensselaer Polytechnic Institute  
Troy, NY 12181

Dr. Van L. Canady  
Senior Planning Associate  
Mobil Chemical Company  
150 E. 42nd Street, Room 746  
New York, NY 10017

Dr. Alan G. Chynoweth  
Executive Director, Electronic Device,  
Process and Materials Division  
Bell Laboratories  
Murray Hill, NJ 07974

Dr. George E. Dieter, Jr.  
Dean, College of Engineering  
University of Maryland  
College Park, MD 20742

Mr. Selwyn Enzer  
Associate Director  
Center for Futures Research  
University of Southern California  
Los Angeles, CA 90007

Dr. Joseph N. Epel  
Director, Plastics Research and  
Development Center  
Budd Corporation  
356 Executive Drive  
Troy, MI 48084

Dr. Larry L. Hench  
Professor and Head  
Ceramics Division  
Department of Metallurgical and  
Materials Engineering  
University of Florida  
Gainesville, FL 32601

Dr. Robert E. Hughes  
Professor of Chemistry  
Executive Director, Materials  
Science Center  
Department of Chemistry  
Cornell University  
Ithaca, NY 14850



Dr. John R. Hutchins III  
Vice President and Director of  
Research and Development  
Technical Staff Division  
Corning Glass Works  
Sullivan Park  
Corning, NY 14830

Dr. James R. Johnson  
Consultant  
River Falls, WI

Mr. William D. Manly  
Senior Vice President  
Cabot Corporation  
125 High Street  
Boston, MA 02110

Dr. James W. Mar  
Professor, Aeronautics and Astronautics  
Building 33-307  
Massachusetts Institute of Technology  
Cambridge, MA 02139

Dr. Frederick T. Moore  
Industrial Advisor  
Industrial Development and  
Finance Department  
World Bank  
1818 H Street, N.W., Room D422  
Washington, DC 20431

Dr. Nathan E. Promisel  
Consultant  
12519 Davan Drive  
Silver Spring, MD 20904

Dr. Allen S. Russell  
Vice President-Science and Technology  
Aluminum Company of America  
1501 Alcoa Building  
Pittsburgh, PA 15219

Dr. Jason M. Salsbury  
Director Chemical Research Division  
American Cyanamid Company  
Berdan Avenue  
Wayne, NJ 07470

Dr. John J. Schanz, Jr.  
Assistant Director, Center for  
Policy Research  
Resources for the Future  
1755 Massachusetts Avenue, N.W.  
Washington, DC 20036

Dr. Arnold J. Silverman  
Professor, Department of Geology  
University of Montana  
Missoula, MT 59801

Dr. William M. Spurgeon  
Director, Manufacturing and  
Quality Control  
Bendix Corporation  
24799 Edgemont Road  
Southfield, MI 48075

Dr. Morris A. Steinberg  
Director, Technology Applications  
Lockheed Aircraft Corporation  
Burbank, CA 91520

Dr. Roger A. Strehlow  
Professor, Aeronautical and  
Astronautical Engineering  
University of Illinois at Urbana  
101 Transportation Building  
Urbana, IL 61801

Dr. John E. Tilton  
Professor, Department of Mineral  
Economics  
221 Walker Building  
Pennsylvania State University  
University Park, PA 16802

**NMAB STAFF:**

W. R. Prindle, Executive Director  
R. V. Hemm, Executive Secretary

**NATIONAL MATERIALS ADVISORY BOARD  
COMMITTEE ON FIRE SAFETY ASPECTS OF POLYMERIC MATERIALS**

**Chairman**

HERMAN F. MARK, Emeritus Dean, Polytechnic Institute of New York, Brooklyn.

**Members**

ERIC BAER, Head, Division of Macromolecular Science, Case-Western Reserve University, Cleveland, Ohio

ALFRED E. BROWN, Celanese Corporation, New York.

JOHN M. BUTLER, Manager, Organic Polymer Synthesis, Monsanto Research Corp., Dayton, Ohio.

RAYMOND FRIEDMAN, Vice President and Scientific Director, Factory Mutual Research Corp., Norwood, Massachusetts.

ALFRED R. GILBERT, Manager, Organic and Polymer Chemistry Branch, Chemistry Laboratory, Corporate R&D, General Electric Company Schenectady, New York.

CARLOS J. HILADO, Research Professor, Institute of Chemical Biology, University of San Francisco, California.

RAYMOND R. HINDERSINN, Section Manager, Research Center, Hooker Chemical Co., Niagara Falls, New York.

WILLIAM C. HUSHING, Vice President, Kensington Management Consultants, Bath, Maine.

FRANK E. KARASZ, Professor and Co-Director, Materials Research Laboratory, Polymer Science & Engineering Dept., University of Massachusetts, Amherst.

TED A. LOOMIS, Professor & Chairman, Department of Pharmacology, School of Medicine, University of Washington, Seattle.

RICHARD S. MAGEE, Associate Professor, Department of Mechanical Engineering, Stevens Institute of Technology, Hoboken, New Jersey.

ELI M. PEARCE, Head, Department of Chemistry, Professor of Polymer Chemistry and Chemical Engineering, Polytechnic Institute of New York, Brooklyn, New York.

CHARLES F. REINHARDT, Director, Haskell Laboratory for Toxicology and Industrial Medicine, E. I. duPont Nemours and Co., Newark, Delaware.

ARNOLD ROSENTHAL, Celanese Research Company, Summit, New Jersey.

DONALD G. SMILLIE, Chief Structures Development Engineer, McDonnell Douglas Corp., Long Beach, California.

GIULIANA C. TESORO, Adjunct Professor, Massachusetts Institute of Technology, 278 Clinton Avenue, Dobbs Ferry, New York.

NICHOLAS W. TSCHOEGL, Professor Department of Chemical Engineering, Division of Chemistry and Chemical Engineering, California Institute of Technology, Pasadena California.

ROBERT B. WILLIAMSON, Associate Professor of Engineering Science, Dept. of Civil Engineering, University of California, Berkeley, California.

#### **Liaison Representatives**

JEROME PERSH, Staff Specialist for Materials and Structures, ODUSDRE(ET), Department of Defense, Washington, D.C.

ERNEST B. ALTERKRUSE, Chief, Department of Clinics, Moncrief Army Hospital, Fort Jackson, Columbia, South Carolina.

ALLAN J. McQUADE, U.S. Army Natick Laboratories, Natick, Massachusetts.

GEORGE R. THOMAS, Department of the Army, Army Materials and Mechanics Research Center, Watertown, Massachusetts.

HERBERT C. LAMB, Naval Facilities Engineering Command, Alexandria, Virginia.

DANIEL PRATT, Naval Ships Engineering Center, Prince George's Center, Hyattsville, Maryland.

GEORGE SORKIN, Naval Sea Systems Command, Washington, D.C.

JACK ROSS, Wright-Patterson Air Force Base, Ohio

BERNARD ACHHAMMER, National Aeronautics and Space Administration, NASA Headquarters, Advanced Research and Technology Division, Washington, D.C.

JOHN A. PARKER, National Aeronautics and Space Administration, Ames Research Center, Moffett Field, California

ARNOLD WEINTRAUB, Energy Research and Development Administration, Washington, D.C.

DAVID FORSHEY, Bureau of Mines, Washington, D.C.

CLAYTON HUGGETT, Center for Fire Research, National Bureau of Standards, Washington, D.C.

LESLIE H. BREDEN, Fire Safety Engineering Division, Center for Fire Research, National Bureau of Standards, Washington, D.C.

IRVING LITANT, Department of Transportation (DoT), Systems Center, Kendall Square, Cambridge, Massachusetts.

GEORGE BATES, JR., Department of Transportation, Federal Aviation Administration, Washington, D. C.

RALPH RUSSELL, Aircraft Division, DoT, Federal Aviation Administration, National Aviation Facilities Experimental Station, Atlantic City, New Jersey.

PAUL W. SMITH, Aviation Toxicology Laboratory, Civil Aeromedical Institute, Oklahoma City, Oklahoma.

THOMAS G. HOREFF, DoT Federal Aviation Administration, Washington, D.C. (Until September 1974).

DANIEL F. SHEEHAN, DoT, U. S. Coast Guard, Washington, D. C.

WILLIAM J. WERNER, Department of Housing and Urban Development, Washington, D. C.

DONALD L. MOORE, Department of Housing and Urban Development, Washington, D. C.

IRVING GRUNTFEST, Environmental Protection Agency, Washington, D. C.

NELSON GETCHELL, U. S. Dept. of Agriculture, Beltsville, Maryland.

WILSON A. REEVES, Cotton Finishes Laboratory, U. S. Dept. of Agriculture, New Orleans, Louisiana.

HERBERT W. EICHNER, Forest Service, U. S. Dept. of Agriculture, Forest Products Laboratory, Madison, Wisconsin.

RICHARD E. WIBERG, National Institute for Occupational Safety and Health, Rockville, Maryland.

JAMES RYAN, Consumer Product Safety Commission, Bethesda, Maryland.

JURGEN KRUSE, Materials Research Div., Office of Postal Science and Technology, Rockville, Maryland.

#### **Technical Advisors**

IRVING N. EINHORN, Flammability Research Center, Division of Materials Science and Engineering, Flammability Research Center, College of Engineering, University of Utah, Salt Lake City.

MAUREE W. AYTON, Science Information Analyst, Congressional Research Service, Library of Congress, Washington, D. C.

#### **National Materials Advisory Board Staff**

ROBERT S. SHANE, National Materials Advisory Board, National Academy of Sciences, Washington, D.C.

#### **Technical Editor**

ISRAEL KATZ, Professor of Engineering Technology, Northeastern University, Boston, Mass.

## CONTENTS

Chapter 1	Introduction	1
1.1	Scope and Methodology of the Study	1
1.2	Scope and Limitations of This Report	2
1.3	Organization	4
1.3.1	State of the Art Review	4
1.3.2	Highlights of Chapters	4
1.4	Building Fire – Human Factors	5
1.4.1	Introduction	5
1.4.2	Indifference to the Fire Threat	5
1.4.3	Ignorance of Fire Hazard	5
1.4.4	Incendiarism	6
1.4.5	Panic	6
1.4.6	Toxicology	6
1.4.7	Summary of Building Fire Human Factors	6
1.5	Committee Viewpoints	6
Chapter 2	Summary of Conclusions and Recommendations	8
2.1	Introduction and Advice to the Reader	8
2.2.2	Principle Conclusions and Recommendations (but see individual chapters)	8
2.2.1	Fire Dynamics (Chapter 3)	8
2.2.2	Conclusions and Recommendations on Materials (Chapter 4)	9
2.2.2.1	Materials Used	9
2.2.2.2	Building Structure	10
2.2.2.3	Residential Occupancies	10
2.2.2.4	Other Occupancies	11
2.2.3	Conclusions and Recommendations on Test Methods and Standards (Chapter 5)	11
Chapter 3	Development and Analysis of Fire Scenarios	12
3.1	Introduction	12
3.2	Summary of Statistics on Building Fires	13
3.2.1	U.S. Fire Deaths	13
3.2.2	When, Where, and How Fatal Residential Fires Start	16
3.2.3	Property Loss from Fires	21
3.2.4	Summary	22
3.3	Fire Scenario Development	22
3.3.1	Guidelines for Development	22
3.3.1.1	Prefire Situation	24
3.3.1.2	Ignition Source	24

3.3.1.3	Ignited Material	25
3.3.1.4	Flaming or Smoldering Combustion	27
3.3.1.5	Fire Spread	27
3.3.1.5.1	General	27
3.3.1.5.2	Fire Spread Over the Initially Ignited Material	28
3.3.1.5.3	Fire Spread to Secondary Material	28
3.3.1.6	Evolution of Smoke and Toxic Gases	29
3.3.1.6.1	General	29
3.3.1.6.2	Automatic Detection (See also Section 6.2.2.3)	29
3.3.1.6.3	Visibility	30
3.3.1.6.4	Toxic Effects	30
3.3.1.7	Extinguishment	31
3.3.1.8	Flashover	31
3.3.1.9	Spread to Adjacent Compartments and Catastrophic Failures	32
3.3.1.10	Spread to Other Structures	33
3.3.1.11	Essential Fire Scenario Elements (Check List)	34
3.3.2	Capsule Scenarios	35
3.3.2.1	Residential Buildings	35
3.3.2.2	Mobile Homes	37
3.3.2.3	Non-residential Buildings	38
3.3.2.4	Custodial Buildings	39
3.3.2.5	Summary	40
3.4	Fire Scenarios Analysis	41
3.4.1	Guidelines for Analysis	41
3.4.1.1	Prefire Situation	41
3.4.1.2	Ignition Source	41
3.4.1.3	Ignited Material	41
3.4.1.4	Flaming or Smoldering Combustion	42
3.4.1.5	Fire Spread	42
3.4.1.6	Smoke and Toxic Gases	42
3.4.1.7	Extinguishment	43
3.4.1.8	Flashover	43
3.4.1.9	Postflashover	43
3.4.1.10	Spread to Other Structures	43
3.4.1.11	Summary	44
3.4.2	Analysis of Selected Scenarios	44
3.4.2.1	Single-Family Home	44
3.4.2.2	Apartment Fire	47
3.4.2.3	Nursing Home Fire	47
3.4.2.4	Nuclear Power Plant Fire	51
3.5	Conclusions and Recommendations	54
3.5.1	Conclusions	54
3.5.2	Recommendations	55

Chapter 4	Materials	57
4.1	Introduction	57
4.2	Materials	57
4.2.1	Wood and Wood Products	58
4.2.2	Plastics	60
4.2.2.1	Polyvinyl Chloride	62
4.2.2.2	Styrene Polymers	63
4.2.2.3	Polyolefins	64
4.2.2.4	Phenol-Formaldehyde	65
4.2.2.5	Urea-Formaldehyde, Melamine-Formaldehyde	65
4.2.2.6	Reinforced Polyesters	66
4.2.2.7	Acrylics	67
4.2.2.8	Nylon	67
4.2.2.9	Epoxy	68
4.2.2.10	Polycarbonates	68
4.2.2.11	Acetals	69
4.2.3	Foams	69
4.2.3.1	Polyurethane Foam	70
4.2.3.1.1	Usage	70
4.2.3.1.2	Combustibility Considerations	71
4.2.3.2	Polystyrene	72
4.2.3.3	Polyvinyl Chloride (PVC)	73
4.2.3.4	Rubber	73
4.2.3.5	Urea-Formaldehyde	74
4.2.3.6	Phenol-Formaldehyde	75
4.2.3.7	Polyolefin	75
4.2.4	Fibers	75
4.2.4.1	Cellulosics	76
4.2.4.2	Wool	77
4.2.4.3	Nylon	77
4.2.4.4	Acrylics	77
4.2.4.5	Polyesters	78
4.2.4.6	Polyolefin	78
4.2.4.7	Blends	78
4.2.5	Elastomers	79
4.2.6	Coatings	79
4.2.7	Asphalt	80
4.2.8	Conclusions and Recommendations	81
4.3	Building Structure	83
4.3.1	Classification of Building Construction	83
4.3.1.1	Fire Resistive Construction	83
4.3.1.2	Noncombustible/Limited-Combustible Construction	84
4.3.1.3	Heavy Timber Construction	84

4.3.1.4	Ordinary Construction	84
4.3.1.5	Wood Frame Construction	85
4.3.1.6	Unconventional Construction	85
4.3.2	Building Elements	86
4.3.2.1	Structural Frame	86
4.3.2.2	Exterior Walls	87
4.3.2.3	Partitions	88
4.3.2.4	Interior Finish	88
4.3.2.5	Floors	90
4.3.2.6	Roofs	92
4.3.2.6.1	Wood in Roofs	93
4.3.2.6.2	Asphalt in Roofs	93
4.3.2.6.3	Plastic Components of Roofs	94
4.3.2.7	Insulation	95
4.3.2.8	Ceilings	96
4.3.2.9	Doors	97
4.3.2.10	Trim	97
4.3.2.11	Skylights and Glazing	98
4.3.3	Utilities and Services	98
4.3.3.1	Electrical Conductor Insulation	99
4.3.3.2	Ducting	101
4.3.3.3	Piping	101
4.3.3.4	Plumbing Fixtures	103
4.3.3.5	Lighting	104
4.3.4	Conclusions and Recommendations	104
4.4	Residential Occupancies	106
4.4.1	Structures	106
4.4.2	Contents	106
4.4.2.1	Furniture	106
4.4.2.1.1	Furniture Types and Construction	107
4.4.2.1.2	Fire Safety of Furniture	110
4.4.2.2	Floor Coverings	112
4.4.2.3	Mattresses	120
4.4.2.4	Curtains and Draperies	121
4.4.2.5	Major Appliances	122
4.4.3	Conclusions and Recommendations	125
4.5	Other Occupancies	126
4.5.1	Hotels, Motels, Dormitories and Rooming Houses	126
4.5.2	Mobile Homes	131
4.5.3	Office Buildings	134
4.5.4	Hospitals, Nursing Homes, Related Care Centers, and Other Custodial Buildings	136
4.5.5	Retail Stores, Malls, etc.	138



4.5.6	Restaurants and Nightclubs	140
4.5.7	Public Assembly Occupancies – Auditoria, Theaters, Exhibition Halls, Arenas, Transportation Terminals, Etc.	145
4.5.8	Education Occupancies	146
4.5.9	Industrial	148
Chapter 5	Test Methods and Standards	154
5.1	Introduction	154
5.2	Test Methods	155
5.3	Standards and Codes	155
5.3.1	Fire Safety Provisions in Building Codes	155
5.3.2	Specific Standards and Code Criteria Relating to Polymeric Materials	162
5.3.3	Mobile Home Standards	163
5.4	Discussion of Test Methods	163
5.4.1	Ignition Tests	163
5.4.2	Flame Spread Tests	165
5.4.3	Rate of Heat Release Tests	171
5.4.4	Tests for Oxygen Requirement	172
5.4.5	Extinguishment Tests	174
5.4.5.1	Portable Extinguishers	174
5.4.5.2	Automatic Sprinklers	175
5.4.6	Tests for Smoke Evolution	176
5.4.7	Tests for the Assessment of the Toxicological Aspects of Pyrolysis and Combustion Products	178
5.4.8	Tests for Fire Endurance	181
5.4.9	Full-Scale Fire Tests	183
5.5	Conclusions and Recommendations	185
Chapter 6	Elements of Fire Safety and Design	189
6.1	Introduction	189
6.2	A Systems Approach to Design	191
6.2.1	Prevent Fire Ignition	191
6.2.1.1	Control Ignition Energy Source	192
6.2.1.2	Control Thermal Energy Transfer	193
6.2.1.3	Control Fuel	194
6.2.2	Manage Fire	194
6.2.2.1	Control Fire by Construction	194
6.2.2.2	Control Combustion	195
6.2.2.3	Detection	196
6.2.2.4	Suppress Fire	198
6.2.3	Manage “Exposed”	200

# CHAPTER 1

## INTRODUCTION

### 1.1 Scope and Methodology of the Study

The charge to the NMAB Committee on Fire Safety Aspects of Polymeric Materials was set forth in presentations made by the various sponsoring agencies. Early in its deliberations, however, the committee concluded that its original charge required some modification and expansion if the crucial issues were to be fully examined and the needs of the sponsoring organizations filled. Accordingly, it was agreed that the committee would direct its attention to the behavior of polymeric materials in a fire situation with special emphasis on human-safety considerations. Excluded from consideration were firefighting, therapy after fire-caused injury, and mechanical aspects of design not related to fire safety.

The work of the committee includes (1) a survey of the state of pertinent knowledge; (2) identification of gaps in that knowledge; (3) identification of work in progress; (4) evaluation of work as it relates to the identified gaps; (5) development of conclusions; (6) formulation of recommendations for action by appropriate public and private agencies; and (7) estimation, when appropriate, of the benefits that might accrue through implementation of the recommendations. Within this framework, functional areas were addressed as they relate to specific situations; end uses were considered when fire was a design consideration of concern to the sponsors of the study.

Attention was given to natural and synthetic polymeric materials primarily in terms of their composition, structure, their ease of processing, and geometry (i.e., film, foam, fiber, etc.), but special aspects relating to their incorporation into an end-use component or structure also were included. Test methods, specifications, definitions, and standards that deal with the foregoing were considered. Regulations, however, were dealt with only in relation to end uses.

The products of combustion, including smoke and toxic substances, were considered in terms of their effects on human safety; morbidity and mortality were treated only as a function of the materials found among the products of combustion. The question of potential exposure to fire-retardant polymers, including skin contact, in situations not including pyrolysis and combustion were addressed as deemed appropriate by the committee in relation to various end uses.

In an effort to clarify the understanding of the phenomena accompanying fire, consideration was given to the mechanics of mass and energy transfer (fire dynamics). The opportunity to develop one or more scenarios to guide thinking was provided; however, as noted above, firefighting was not considered. To assist those who might use natural or synthetic polymers in components or structures, consideration also was given to design principles and criteria for selection of materials.

## BUILDINGS

In organizing its work, the committee concluded that its analysis of the fire safety of polymeric materials should address the materials themselves, the fire dynamics situation, and the large societal systems affected. This decision led to the development of a reporting structure that provides for separate treatment of the technical-functional aspects of the problem and the aspects of product end use.

Accordingly, as the committee completes segments of its work, it plans to present its findings in the following five disciplinary and five end use reports:

Volume 1	Materials — State of the Art
Volume 2	Test Methods, Specifications, and Standards
Volume 3	Smoke and Toxicity (Combustion Toxicology of Polymers)
Volume 4	Fire Dynamics and Scenarios
Volume 5	Elements of Polymer Fire Safety and Guide to the Designer
Volume 6	Aircraft (Civil and Military)
Volume 7	Residential, Non-Residential and Custodial Buildings
Volume 8	Land Transportation Vehicles
Volume 9	Ships
Volume 10	Mines and Bunkers

Some of the polymer applications and characteristics are in the classified literature, and the members of the committee with security clearances believed that this information could best be handled by special meetings and addenda reports to be prepared after the basic report volumes were completed. Thus, the bulk of the output of the committee would be freely available to the public. Considering the breadth of the fire safety problem, it is believed that exclusion of classified information at this time will not materially affect the committee's conclusions.

### 1.2 Scope and Limitations of This Report

This seventh volume in the series of reports by the NMAB Committee on Fire Safety Aspects of Polymeric Materials concerns itself with buildings and their normal contents, i.e., furnishings. The threat to life and property posed by building fires critically involves polymeric materials in a majority of instances.

This volume seeks to review and analyze the pertinent factors relevant to building fires involving polymers, to draw conclusions based on the present state of the art, and to make recommendations which, if implemented, should reduce fire loss.

The primary emphasis of this volume is the fire threat to human life. The overwhelming majority of the 11,000 to 12,000 fire deaths per year which occur in the United States occur in buildings. The U.S. fire fatality rate per capita is much higher than that of any other developed country, and up to 10 times as high as that of some countries. This volume is motivated by the feeling that such statistics are unacceptable, and improvements are needed. However, further introduction of

## INTRODUCTION

synthetic polymeric materials into homes and other buildings could increase the threat even above the present level.

While the life threat is emphasized throughout this volume, some recognition is also made of property losses or interruption of operation of key facilities caused by fire. The direct property loss of buildings by fire in the United States in 1975 was estimated at \$3.4 billion dollars; (see section 3.2.3) one should probably double this figure if one wished to include indirect costs of building fires such as business interruption, dislocation of workers, and possible disruption of strategic services (telephone exchange, power generation plant, computer center, record center, etc.).

This volume provides analyses of both residential and non-residential buildings. The majority of building fire fatalities (close to 90%) occur in residential buildings. On the other hand, about 60% of the building fire property loss occurs in non-residential buildings.

Certain classes of buildings deserve and have received special attention. Custodial or institutional buildings containing occupants of little or no mobility are especially vulnerable to fire; examples are nursing homes, hospitals, and prisons. Another special category is places of public assembly (restaurants, clubs, theaters, exhibition halls, large retail stores, etc.) where fire may induce panic in a crowd. Yet another concern is the high-rise building, residential and non-residential, from which it may be impossible to evacuate large numbers of people on upper floors fast enough, under fire conditions.

Mobile homes, which account for about 7% of U.S. fire deaths, are of special concern, because they may contain a much greater concentration of flammable materials than a conventional home.

Synthetic polymers are used in large and rapidly growing amounts in all types of buildings. In 1976, 4.8 billion pounds of plastics were used in "buildings and construction," and an additional 1.8 billion pounds in "furniture and furnishings;" both figures being substantially larger than in previous years. These synthetic polymers in many cases ignite more readily, burn more vigorously, and/or produce greater quantities of smoke than natural polymers, such as wood, which they may replace. In some cases they are used as replacement for inorganic materials.

In this volume, an attempt is made to identify the major categories of polymeric materials used in buildings, especially residential buildings, the ways in which the polymeric materials are used, and the potential fire threats posed thereby. Means for ameliorating this fire threat are reviewed, and specific recommendations are made. The committee accepts the concept that substantial quantities of polymeric materials will continue to be used in the residential environment, for both economic and esthetic reasons, in spite of the fire threat. The approach, then, is to find a safer way of living with this situation, by (a) eliminating the most drastically hazardous polymeric materials applications; (b) calling for general improvements in fire resistance of polymeric materials when appropriate and economically feasible; (c) recognizing that alternate routes to fire safety exist aside from modifying the

materials, such as improved fire detection, fire suppression, or escape routes, and reduction of the probability of ignition.

Ignited smoking materials are by far the most common cause of fatal building fires. These set fire to upholstered furniture or bedding. In this case, the curative alternatives are: induce smokers to be more careful; modify cigarettes so that they self-extinguish more readily; fire-harden the furniture coverings; provide smoke detectors and escape routes (not valid for immobile people or unattended small children); automatically suppress the fire, as with a sprinkler system. These and other factors are discussed in depth in this volume.

Professional firefighting activities are specifically excluded as outside the scope of this study.

### **1.3 Organization**

#### **1.3.1 State of the Art Review**

A state-of-the-art review is a part of each of four chapters: Fire Scenarios (Chapter 3); Materials (Chapter 4); Test Methods and Standards (Chapter 5). and Fire Safety and Design (Chapter 6). Finally, Chapter 7 provides discussion and reviews highlights of specific hazardous situations, or problem areas, involving polymeric materials and building fires. Each chapter terminates in conclusions and recommendations as appropriate. These are summarized in Chapter 2.

#### **1.3.2 Highlights of Chapters**

Chapter 3, Fire Scenarios, summarizes statistics on building fires, provides guidelines for development and analysis of fire scenarios (presented in greater depth in Volume 4), presents sixteen capsule scenarios of building fires involving polymeric materials, (inspired by real incidents and illustrating the most common hazardous situations), and, finally, presents and analyzes three scenarios in depth. The message of this chapter is that identification of the most probable fire scenarios must be accomplished for effective fire prevention and control.

Chapter 4, Materials, reviews systematically the relevant properties of specific types of polymeric materials used in building construction and furnishings (organized into categories of wood and wood products, plastics, foams, fibers, elastomers, coatings), identifies application of these materials for residential buildings and for specific types of non-residential buildings, and reviews the elements of building structure and building contents for types and quantities of polymeric materials used and potential fire problems.

Chapter 5, Test Methods and Standards, lists the commonly used test methods for determining fire safety properties of these polymeric materials, provides a critical discussion of the limitations of these test methods, and discusses the standards and codes used to control building fire safety. (A more thorough discussion of test methods and standards will be found in Volume 2).

Chapter 6, Fire Safety and Design, is more philosophical in nature; it reviews one

proposed systems approach. Specific and preferably quantitative fire safety objectives should be formulated; alternate paths available to reach those objectives should be reviewed; and a determination should be made of the most cost-effective path or combination of paths which achieves the objectives. Reliability considerations are very important, and redundancy should be considered.

Chapter 7, Major Polymeric Material-Fire Hazards in Buildings, highlights and discusses important specific building fire hazards, which have already been mentioned in previous chapters on scenarios, materials, test methods, or design.

With few exceptions, the cutoff date for literature searched for this volume is July 1976.

### **1.4 Building Fire – Human Factors**

#### **1.4.1 Introduction**

People are not only the victims of fire; in the majority of cases they cause fires. Modifying the behavior of people is outside the scope of this study. The charge to the committee is to study the physical rather than the human behavioral aspect of polymer fire safety. Accordingly, the membership of the committee represents polymer expertise and fire phenomenology expertise, but not expertise in psychology or in public education. Nevertheless, it seems appropriate in this introduction to acknowledge that these human factors exist and have high relevance, even though they are not treated in this study. Some of the important human factors will be identified but will not be discussed in detail.

#### **1.4.2 Indifference to the Fire Threat**

Perhaps the most important human factor is the widespread indifference of people in the United States to the fire threat. This results in careless smoking habits, unnecessary accumulations of flammable rubbish, tolerance of known substandard electrical installations, e.g. frayed wiring, permitting small children access to matches, purchases of flammable products when less flammable versions are readily available, and failure to buy and install an inexpensive reliable smoke detector. The fire deaths per capita in Japan and Switzerland are tremendously lower than in the United States. This is very likely due to the greater indifference of the U.S. public to fire hazards. This committee cannot judge whether this prevailing attitude can be changed.

#### **1.4.3 Ignorance of Fire Hazard**

The second important human factor is the lack of public knowledge about important aspects of fire. It is not a matter of common knowledge that many synthetic polymers are highly flammable. Many erroneously think that, since an abandoned cigarette *usually* will fail to ignite a sofa (except for local scorching), it will *invariably* fail to produce a sustained fire. There is vast ignorance of the degree of danger to building occupants, once a fire is discovered. The necessity of keeping one's head below the smoke layer is not universally known. The speed with which

a fire can develop into room flashover (discussed later in Chapters 3 and 5) surprises most people. Hazards of using an elevator during a high-rise building fire are not widely understood (discussed in Chapter 6). Better education on fire safety in the public schools is certainly needed, but implementing this is outside the scope of this committee.

### 1.4.4 Incendiarism

It is believed that a substantial cause of building fires is incendiarism. This appears to occur more commonly in apartment buildings than in single-family homes, presumably because of easier access to building interiors. One answer may be more vigorous law enforcement; but, such matters are not considered in this volume.

### 1.4.5 Panic

Panic, which may be induced in a crowd by a fire, is another human factor. Even a lone individual who awakens to find smoke and fire may experience disorientation, if not panic. It has been alleged that the purely psychological effects may be aggravated by physiological effects of inhaled fire gases.

### 1.4.6 Toxicology

Volume 3 of this study deals with one of the human factors, namely the toxicological consequences of breathing combustion products of polymers. However, our study does not delve into psychological effects.

### 1.4.7 Summary of Building Fire Human Factors

This committee feels that human factors have great significance to the fire problem. It feels that the approach to these problems is very difficult. Accordingly, it seems worthwhile to approach fire safety by improving the physical factors where feasible. However, there is no desire to discourage addressing these human factors in depth.

## 1.5 Committee Viewpoints

Many statements about the fire safety aspects of polymeric materials appear in each of the volumes of the report. Members of the committee wish to emphasize that such statements, including judgmental ones in regard to fire safety aspects of materials, especially relative to end usage, apply only to the specific situations that pertain (e.g., suitability of a material from a fire safety point of view depends on many factors, including ease of access, ease of occupant egress, proximity of ignition hazard, proximity of other materials, thermal flux and duration of ignition source, ambient oxygen partial pressure, and fire and smoke detection and suppression systems in place).<sup>1</sup>

<sup>1</sup> This list is not all-inclusive, but only indicative of the kinds of concerns that must be considered in making a materials selection.

## INTRODUCTION

Statements in this volume must not be taken out of context and applied to the use of identical materials in other situations. In addition, the changing nature of the problem, as times goes on and additional experience is acquired, must be recognized by the reader as it was by the committee. This viewpoint must be emphasized so that information that appears in the published report of this committee's study is not misused by taking it out of context.



## CHAPTER 2

### SUMMARY OF CONCLUSIONS AND RECOMMENDATIONS

#### 2.1 Introduction and Advice to the Reader

Synthetic polymeric materials are replacing other materials to a major extent in building construction and building contents. Since the combustion characteristics are frequently different *inter alia*, with regard to ease of ignition, rate of fire growth, nature of combustion products, etc., cases can arise where hazard to building occupants is significantly increased. In this volume, many hazardous situations are identified and recommendations are made for reducing the hazard.

In general, reducing the hazard may be accomplished by a variety of approaches, e.g.: (1) banning specific materials for specific applications, on the basis of realistic tests and/or field experience; (2) improvement of materials by use of new ingredients, additives, or combinations; (3) improvement of materials test methods; (4) reduction of ignition sources, as by developing self-extinguishing cigarettes and matches; (5) greater use of automatic detection and suppression systems; (6) upgrading building codes; (7) educating the public.

To put the problem in perspective, all of these approaches are being pursued in the United States, with varying degrees of vigor; the life loss from fire (primarily in residential buildings) seems to be stabilized. There is no statistical basis for predicting a major increase of loss of life in the future because of polymeric material usage. However, this "stabilized" life loss in the United States does amount to many thousands of deaths per year. Also billions of dollars of property loss are incurred annually. A continuing major effort to control and hopefully reduce these losses is justified. If the recommendations of this study are energetically pursued, (the committee confidently predicts that) a substantial reduction in fire loss should be accomplished.

Chapter 7 presents a condensed overview of six of the most serious hazard areas. Chapters 3, 4, 5 and 6 review scenarios, materials, test methods and standards, and building design factors, respectively; conclusions and recommendations are to be found at the end of each of these chapters. Roughly one-third of these conclusions and recommendations are tabulated in this chapter. These are the most general and highest priority conclusions and recommendations; but, the interested reader should look further into the volume for a more complete list.

#### 2.2 Principle Conclusions and Recommendations (but see individual chapters)

##### 2.2.1 Fire Dynamics (Chapter 3)

*Conclusion:* Although no two building fires are exactly the same, the development and analysis of fire scenarios assists in the identification of common elements in fires. This aids in identification of the critical stages in fire development and suggests opportunities for fire prevention or control.

## SUMMARY OF CONCLUSIONS AND RECOMMENDATIONS

*Recommendation:* Develop a wide spectrum of generalized building fire scenarios, as outlined in Chapter 3, based on real or credible incidents. This should be done by those knowledgeable in fire dynamics and fire safety.

*Recommendation:* Use fire scenarios for the identification of hazards and in the development of methods to provide increased safety. Particularly, these scenarios should contribute to materials selection, design criteria, validation of test methods, development of codes and standards, and definition of research and development objectives.

*Conclusions:* At present, insufficient use is being made of the fire scenario technique to advance fire safety. This is particularly so as new materials are introduced into building designs and furnishings. Fire growth is often observed to follow an exponential law; accordingly, suppression, especially by manual action, may not always be initiated early enough to be effective.

*Recommendation:* Base design and construction of any building, among other things, on the development and testing of the design against appropriate fire scenarios.

### 2.2.2 Conclusions and Recommendations on Materials (Chapter 4)

Needed research in materials is discussed in Volumes 1, 3 and 4. In each case, the needed research is identified; specific research programs are left to be devised by those who will do the work.

#### 2.2.2.1 Materials Used

*Conclusion:* While shredded waste newsprint for insulation is economically and ecologically very attractive, the poor quality control with regard to fire retardant treatment and the susceptibility to leaching of at least some systems introduces a potentially severe fire hazard. Wall coverings and partitions made of thin unbacked plywood and flammable plastic can also be very significant fire hazards.

*Recommendation:* Define the problems in current waste paper insulation systems. Remedy the situation or ban the use as may be appropriate.

*Recommendation:* Prohibit use of unbacked and insulation-backed plywood less than 3/8" thick on walls or ceilings.

*Conclusion:* Major areas of concern in plastic utilization are: plastic furniture, wall coverings; grouped electric and communication cable insulation, particularly in vertical chases; and unconventional building construction using large surfaces of plastic.

*Recommendation:* Continue to upgrade codes on the use of interior finish and decorative materials as new knowledge is developed.

*Recommendation:* When designing large-scale room tests, base these tests upon the types of fire scenarios that represent the real world hazards one is trying to simulate.

*Recommendation:* Require that proponents of new tests and standards demon-

strate a rational relationship between the proposed test or standard and the hazard it is designed to control.

*Conclusions:* Polymers in the form of foam burn faster than in the solid form. Flexible foam cushioning systems have been responsible for much damage and loss of life in fires. This loss is generally associated with the use of smoking materials. Structural foam offers numerous advantages in furniture and other construction. Its use is increasing. Some proposed applications present considerable fire hazard.

*Recommendation:* Modify the design of cigarettes so that abandoned or discarded cigarettes are not capable of igniting upholstered furniture and bedding materials.

*Recommendation:* Continue current studies directed at safer cushioning systems, including cover fabrics, heat sinks, fire barriers and even entirely new foam types.

*Recommendation:* Carefully appraise all structural foam applications for fire safety; perform fire tests on a large prototype scale if necessary.

*Recommendation:* Test foam insulation systems in large prototype scale assemblies prior to use in buildings.

*Conclusion:* Intumescent coatings are an effective means for protecting flammable substrates.

*Recommendation:* Encourage research and development for improvement in cost and durability of intumescent coatings.

### 2.2.2.2 Building Structure

*Conclusion:* Plastic piping offers cost and other advantages. Such use, however, can add to the fire hazard in buildings.

*Recommendation:* Reduce the hazard from plastic pipe to an acceptable level by use of appropriate building design and installation procedures.

*Conclusion:* The "energy crisis" has fostered a number of do-it-yourself energy conservation measures. Many of these create potential fire hazards (e.g., interior plastic storm glazing, foam sheets over windows and interior walls, etc.).

*Recommendation:* Educate the public on the potential hazards of certain "do-it-yourself" insulation systems.

*Conclusion:* Electrical conductor insulation in grouped cable installations can pose considerable fire hazard.

*Recommendation:* Develop extinguishment and/or fire-stopping systems for grouped insulated cable.

### 2.2.2.3 Residential Occupancies

*Conclusion:* Smoke detectors offer the most rapidly implementable and cost-effective way of increasing fire safety in residential buildings.

*Recommendation:* Promote by educational campaigns, insurance incentives, etc., the installation of smoke detectors in older residential buildings and require installation in new buildings.

## SUMMARY OF CONCLUSIONS AND RECOMMENDATIONS

*Recommendation:* Continue research towards the development and evaluation of home sprinkler systems. Evaluate safety and economic implications.

*Conclusions:* Upholstered furniture is one of the most hazardous items — usually associated with use of smoking materials. “Smoking-in-bed” mattress fires are a large contribution to fire deaths. Mattresses that do not meet the current, more stringent, standard are going to be in use for many years to come.

*Recommendation:* Modify the design of cigarettes so that abandoned or discarded cigarettes are not capable of igniting upholstered furniture and bedding materials.

### 2.2.2.4 Other Occupancies

*Conclusion:* Construction of mobile homes is considerably different from that for conventional housing and undergoes continual change. It is the first place where new housing applications of synthetic polymeric materials appear.

*Recommendation:* Perform thorough large-scale testing on systems that incorporate new applications of polymeric materials in mobile homes. Use the scenario approach to assist in designing “realistic” tests.

### 2.2.3 Conclusions and Recommendations on Test Methods and Standards (Chapter 5)

*Conclusions:* For a long time test methods have been developed with limited understanding of the phenomena of fire growth. Knowledge has advanced considerably in the last decade; the development of more meaningful test methods based on the science of fire dynamics can now be attempted. Many currently used test methods and criteria for fire hazards were developed on the basis of experience with cellulosic materials. These tests are not necessarily adequate for the evaluation of fire hazards of synthetic polymers.

*Recommendation:* Continue work on tests of interior finish materials for fire hazards; the currently used ASTM E-84 test must be improved or replaced.

*Conclusions:* The rate at which heat is released during burning is an important parameter for evaluating the fire hazard of a particular material. Therefore, reliable tests measuring rate of heat release have great significance and should be developed promptly. Large-scale tests are necessary for qualification of polymeric materials products and to establish the validity of small-scale tests.

*Recommendation:* Correlate surface flame spread test ratings to full-scale fire hazard.

*Recommendation:* Continue the current development of tests for rate of heat release.

## CHAPTER 3

### DEVELOPMENT AND ANALYSIS OF FIRE SCENARIOS

#### 3.1 Introduction

Each of the millions of fires that occur yearly in buildings is the outcome of a chain of events. Some of these events are the result of the development and growth of the fire; others are the consequence of human behavior and/or automatic protection devices. Obviously if one of the links in the chain of events can be removed or altered, the end result of the fire would be altered.

A useful method for analyzing the fire hazard in a particular situation, or from a given product, is to construct typical fire scenarios, i.e., actual or idealized detailed descriptions of fire incidents. This facilitates study and identification of the critical stages in fire development and suggests opportunities for prevention and control methods.

Scenarios have maximum utility if they meet two conditions: 1) they represent accidents causing a significant fraction of the annual loss from fire; and 2) they provide sufficiently detailed information to permit useful analysis.

As to the frequency of occurrence of a specific scenario, accident statistics are helpful as a guide; however, only very limited data are available. While statistical information tells what general types of fires most commonly lead to fatalities (or major property loss), professional fire students certainly need more and better raw statistics. To fully benefit from available information, representative scenarios containing all the relevant details of the fire challenge and the human (or automated) response must be selected for study.

It must also be recognized that statistics are not a good guidepost for certain classes of problems. For example, there is the very infrequent catastrophe of major proportions (e.g., a high-rise building fire) where a statistically valid sample of events is not available; or technological change may occur so rapidly that the time lag between the introduction of a new material, product, or structure and the development of a statistically significant accident history may be unacceptable. In the light of these two factors, judgment is very important in developing meaningful scenarios.

A practical range of fire scenarios can describe in complete detail only a small fraction of the fire incidents that could possibly occur in buildings. Therefore, it is necessary that scenarios treat relevant factors that affect fire development in a way that permits generalization. Scenarios based solely on actual incidents will be retrospective in nature and will be incapable of predicting the effects of new designs and new materials on fire safety unless the teachings of the scenario can be applied to new situations.

The scenario concept is a common tool in long-range planning (Zentner 1975).

However, only recently has the scenario concept been applied to fire-safety program planning. In 1976, the National Bureau of Standards Center for Fire Research employed 5,040 different fire scenarios in developing a research plan to reduce the Nation's fire losses (Nat. Bur. Stand. 1976). The National Fire Protection Association in its publication *Fire Journal* documents the chain of events in many actual fires which it investigates. These real-life fire scenarios have been employed as the basis for in-depth studies of fires in specific residences, e.g., one- and two-family dwellings (NFPA 1975-1), mobile homes (NFPA 1975-2), and nursing homes (NFPA 1972). Other than these instances, there seems to have been little use of the fire scenario approach to improve fire safety.

This chapter is primarily concerned with the development and analysis of fire scenarios. Also included is a summary of statistics on building fires. In keeping with the focus of the study (i.e., on improving fire safety by modifying materials and/or using them better), the physical behavior of fire is emphasized and the behavior of human beings is deemphasized. Nevertheless, it is obvious that people may enter into the fire scenario by: (1) preventing the fire, (2) starting the fire, (3) detecting the fire, (4) extinguishing the fire, (5) escaping from the fire, or (6) being killed or injured by the fire. However, the human psychological and physiological characteristics involved are beyond the scope of this report.

### 3.2 Summary of Statistics on Building Fires

Before the fire scenario approach is discussed it is important to introduce information on where, when and how fires start in buildings, what factors increase the hazard to life, and what is the resulting life and property loss.

#### 3.2.1 U.S. Fire Deaths

Whereas the number of fire deaths has been virtually constant since 1955, the rate of fire deaths has been going down fairly steadily for the past twenty years (see Table 3.1). However, the United States still has the highest fire death rate of an industrialized nation (see Table 3.2).

*Table 3.1. United States Fire Deaths Through the Years (Anon., Fire Journal 1976)*

Year	Estimated No. of Fire Deaths	Rate per Million Inhabitants
1955	11,475	69.5
1960	11,350	63.0
1965	12,000	61.9
1970	12,200	59.9
1971	11,850	57.2
1972	11,900	57.1
1973	11,700	55.7
1974	11,600	55.4
1975	11,800	55.4

## BUILDINGS

Table 3.2. International Fire Losses-1974 (Harlow 1975)

Country	Fires Per		Fire		Estimated <sup>1</sup>
	1,000 Population	Fire Deaths Per Million	Injuries Per 1,000	Fire Loss Per Capita (US Dollars)	
Australia	7.5	12.58	0.16	\$16.30	
Austria <sup>4</sup>	1.24	n.avail.	n.avail.	5.56	
Belgium	1.41	16.5	0.074	n.avail.	
Canada <sup>4</sup>	3.37	32.95	n.avail.	14.70	
France	1.87	5.6	0.040	11.95	
Germany	n.avail.	n.avail.	n.avail.	9.99 <sup>5</sup>	
Italy	1.55	3.6	0.13	2.7	
Japan <sup>4</sup>	0.70	18.0	0.09	2.83	
The Netherlands	1.68	4.07	0.036	8.34	
New Zealand	12.78	13.1	0.09	n.avail.	
Norway <sup>4</sup>	n.avail.	17.4	n.avail.	15.03	
Sweden	n.avail.	13.1	n.avail.	13.04	
Switzerland	1.47	n.avail.	n.avail.	7.16 <sup>5</sup>	
United Kingdom <sup>3</sup>	5.6 <sup>2</sup>	18.4 <sup>2</sup>	0.116 <sup>2</sup>	9.19	
United States	14.1	55.4	0.58	18.08	

<sup>1</sup> Comparisons of monetary loss should be made with care due to recent fluctuations in exchange rates. <sup>2</sup> Provisional estimates. <sup>3</sup> Does not include Northern Ireland. <sup>4</sup> 1973 Data -- later data not available. <sup>5</sup> Insured property only. n.avail. = Not available.

Most of the fire deaths occur in residences. Clark and Ottoson (1976) utilized the FIDO<sup>1</sup> (Fire Incident Data Organization) file maintained by NFPA to compile the figures shown in Table 3-3.

Since the FIDO file is maintained from reports submitted by fire departments, relatively few fire fatalities caused solely by apparel fire are included. This reflects the fact that the apparel fire is usually small, and often is not reported to the fire service. The FIDO data, corrected for apparel-related fire deaths, is also shown in Table 3.3. (It should be noted that aircraft-related fire deaths are not part of either set).

Table 3.4 shows occupancies where fire deaths in buildings occur. These figures only include deaths reported to the NFPA Fire Analysis Department; however, the data on which this table is based "is believed to be of sufficient volume and therefore may be used to draw conclusions as to the occupancy distribution of the

<sup>1</sup> FIDO is a computerized file of fire experience containing 30,000 fire related incidents from 1971 to 1975. The incidents are primarily fires causing death, injury, or major property loss (50,000 or greater). These fires include approximately 11,000 fatalities, or about 20 percent of all fire deaths in the United States, in the period 1971-75.

DEVELOPMENT AND ANALYSIS OF FIRE SCENARIOS

Table 3.3. Where US Fire Deaths Occur (Clark and Ottoson 1976)

<u>FIDO</u>		<u>FIDO Adjusted</u>	
<u>Occupancy</u>	<u>Per Cent</u>	<u>Occupancy</u>	<u>Per Cent</u>
Residential	84	Residential	72
One-and Two-Family	52	Independent of Struc-	
Apartment	20	ture	14
Mobile Home	7		
Other	<u>5</u>	Apparel	11
	84	Apparel Plus Flam-	
		mable Fluids	<u>3</u>
			14
Institutional	2	Motor Vehicles	4
Public Assembly	2	Industrial	3
Commercial	1	Institutional	2
Industrial	4	Public Assembly	2
Motor Vehicles	4	Commercial	1
Others	<u>3</u>	Others	<u>2</u>
	100		100

Table 3.4. Occupancies where Fire Deaths in Buildings Occur

<u>Occupancy</u>	<u>Percentage of Fire Deaths</u>
1-and 2-Family	63.5
Apartments	22.1
Other Residential	4.1
Hotels and Motels	3.0
Industrial	3.0
All Other Occupancies	<u>4.3</u>
	100.0

various causes of loss of life." (Fire Protection Handbook – 14th ed. – NFPA – Jan. 1976).

More specific fire deaths statistics are shown in Table 3.5, where fire fatalities in buildings in New York City are shown for the period 1967–1972. (Corman, Ignall, Rider and Steven 1976).

The above data clearly illustrate the impact of building fires on U.S. fire deaths. Of particular concern must be the record of fire deaths in private dwellings. If we are to significantly reduce fire deaths in this country, we must focus our attention on reducing fire deaths in residential-type occupancies, particularly in private dwellings.

#### Multiple-Death Fires

Each year, the National Fire Protection Association makes a study of fires in the



## BUILDINGS

*Table 3.5. Fire Fatalities in New York City, 1967-1972*

<u>Type of Building</u>	<u>Number of Fatalities</u>	<u>Percentage of Fatalities</u>
Tenement	558	33
Private residence	340	20
Apartment building	283	17
Single room	81	4.8
Other residential	63	3.7
Store	45	2.7
Garage	25	1.5
Vacant building	25	1.5
Public building	22	1.4
Warehouse	15	0.9
Factory	12	0.7
"Data missing" or "other"	<u>220</u>	<u>13</u>
	1689	100.0*

\* Rounded off.

United States, reported to the Association, in which three or more persons lost their lives. In 1975, more of such multiple-death fires were reported — 250, and there were more deaths — 1,091, than in the last four previous years (see Tables 3.6 and 3.7). For the first time in the past several years, there was no multiple-death fire reported in a nursing home.

Analysis of the data in Table 3.6 indicates that 75.1% of the multiple-death fires occurred in residential buildings.

### Factors Contributing to Fire Fatalities

A detailed study (Fire Protection Handbook 1976) of 500 building fire fatalities reported to the NFPA indicates the factors responsible for the spread of smoke and fire resulting in loss of life (Table 3.8). This table is extremely important when considering the choice and use of particular materials in buildings.

#### 3.2.2. When, Where, and How Fatal Residential Fires Start

An analysis of the fire statistics from 1971 (NFPA 1972) shows that residential fires which kill three or more people usually occur during sleeping hours. Figure 3.1 shows that 59% of all multiple death dwelling fires occur in the night hour period between 10 p.m. and 6 a.m. The worst two hour period occurs shortly after going to bed, i.e. from 10 p.m. to midnight. There may be some deaths in the period identified as waking hours that are more truly represented as sleeping accidents since the very young and the very old may spend more than eight hours sleeping.

The occurrence of multiple death fires can be contrasted with the times when

DEVELOPMENT AND ANALYSIS OF FIRE SCENARIOS

Table 3.6. Where Multiple-Death Fires Occurred in 1975 (NFPA, July 1976)

Occupancy Type	Number of Multiple-Death Fires		Number of Deaths in Multiple-Death Fires	
	By Site (Subtype)	Total By Type	By Site (Subtype)	Total By Type
<b>PUBLIC ASSEMBLY BUILDINGS:</b>		5		32
Restaurants, night-clubs, taverns	4		18	
Other	1		14	
<b>INSTITUTIONAL BUILDINGS:</b>		2		14
Persons	2		14	
<b>RESIDENTIAL BUILDINGS:</b>		201		814
One- and two-family dwellings	138		549	
Apartment houses	43		178	
Mobile homes	12		47	
Other residential buildings	8		40	
<b>STORES AND OFFICES</b>		2		6
<b>BASIC INDUSTRY</b>		3		10
<b>MANUFACTURING:</b>		3		21
Oil Refineries	2		15	
Other Manufacturing	1		6	
<b>STORAGE:</b>		4		14
Grain Elevators	2		7	
Other storage	2		7	
<b>TRANSPORTATION:</b>		17		124
Ships and boats	3		40	
Road vehicles	6		36	
Aircraft	8		48	
<b>OTHER OCCUPANCIES</b>		<u>13</u>		<u>56</u>
<b>TOTAL</b>		<b>250 Fires</b>		<b>1091 Deaths</b>

Table 3.7. Multiple-Death Fires Through the Years (NFPA, July 1976)

	Number of Multiple-Death Fires	Number of Deaths in Multiple-Death Fires
1975	250	1,091
1974	224	916
1973	205	1,008
1972	191	988
1971	208	911

BUILDINGS

Table 3.8. Factors Responsible for the Spread of Smoke and Fire Resulting in Loss of Life

	Types of Occupancies					Other Buildings (Mercantile, Office, Industrial, Storage, and Mixed)
	Residential (Dwellings <sup>1</sup> )	Residential (Other <sup>2</sup> )	Public Assembly Buildings	Institutional Health and Custodial Care	Restrained Care	
<b>Total Fires Analyzed</b>	<b>311</b>	<b>82</b>	<b>8</b>	<b>8</b>	<b>3</b>	<b>88</b>
<b>Building Construction</b>						
<b>Vertical Spread:</b>						
Open stairways	126	38	0	2	0	6
Doors blocked open	6	3	0	0	0	0
Elevator shafts open	0	0	0	0	0	1
Utility shafts open	0	1	0	0	0	0
Nonfirestopped walls	49	13	0	0	0	0
Exterior spread	0	3	0	0	0	0
Other openings	2	0	0	0	0	0
<b>Horizontal Spread:</b>						
Lack of fire walls or fire partitions	1	0	0	0	0	5
Openings in fire walls or fire partitions	0	1	0	0	0	0
Fire doors blocked open or inoperative	0	0	0	0	0	0
Fire doors of improper design	0	1	0	0	0	0
Smoke barriers not provided	6	2	0	2	0	0
Smoke barriers blocked open or residential doors open	30	3	0	0	0	0
Nonfirestopped ceiling areas or undivided attic	20	8	1	0	0	0
Exterior spread	1	0	0	0	0	0
<b>Interior Finish:</b>						
Combustible ceiling finish	63	7	2	3	0	2
Combustible wall finish	107	13	1	2	3	1
Floors soaked with flammable materials	4	0	1	0	0	1
<b>Building Equipment:</b>						
Air conditioning ducts	5	1	0	0	1	1
Conveyor and machinery openings	0	0	0	0	0	1
Fans	3	1	0	0	0	0
Other	0	2	0	1	0	1
<b>Building Contents:</b>						
Decorations	6	3	2	0	0	0
Furniture and fixtures	4	17	0	1	0	1
Flammable liquids not properly contained or handled	59	3	1	0	0	36
Flammable gases not properly contained or handled	19	3	3	1	0	23
Flammable dust or solid chemicals	0	0	0	0	0	16
Explosives and fireworks	1	1	0	0	0	9
Stored material	2	0	1	0	0	7

<sup>1</sup> Dwellings are one- and two-family dwellings only plus mobile homes and recreational vehicles.

<sup>2</sup> Other residential includes multifamily dwellings, apartment houses, hotels, motels, dormitories, fraternity houses, etc., excluding institutional properties. Other occupancies classified are as described in the NFPA Life Safety Code (NFPA No. 101).

dwelling fires occur, including non-fatal as well as fatal fires. It is evident that a small fraction of all fires take place during the sleeping period. The statistics shown in Figure 3.2 illustrate that most residential fires start during waking hours when cooking and other activities requiring open flames take place. Note that 88% of the area under the curve in Figure 3.2 occurs during the waking hours and only 12% under the curve during the sleeping hours. Yet more deaths occur during the sleeping hours than during the waking hours. (There is 41% of the area under the curve in Figure 3.1 during the sixteen waking hours and 59% during the eight sleeping hours). It must be concluded that the greatest risk to lives in residential fires occurs when people are asleep.

The origin of fatal fires is also important. In the previously cited multiple-death fire study (NFPA 1972) the origin of the fires was as shown in Table 3.9.

DEVELOPMENT AND ANALYSIS OF FIRE SCENARIOS

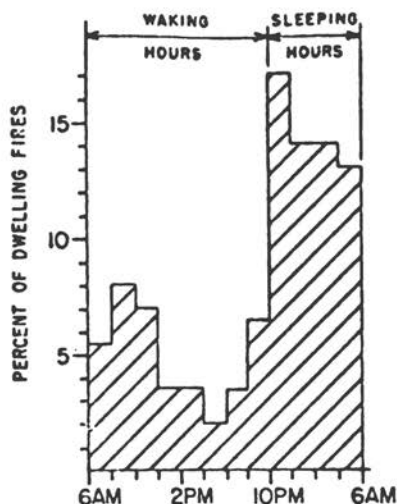

Figure 3.1. Time when fatal dwelling fires start (based on data from multiple death fires, i.e., three or more deaths, from 1971.)

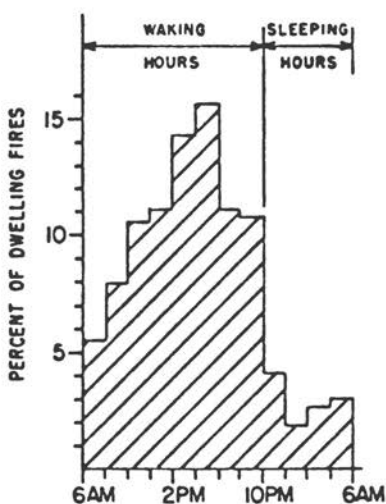

Figure 3.2. Time when all dwelling fires start (based on data from dwelling fires in 1971.)

Table 3.9. Origin of Multiple-Death Fires (NFPA 1972).

Living room, den or family room	33.8%
Basement	25.7
Kitchen	16.2
Bedroom	12.1
Bathroom	4.0
Garage	1.4
Outside	1.4
Unknown	5.4
	<u>100.0</u>

However, these figures do not seem to be consistent with the causes of these fatal fires (Fig. 3.3). The majority of the multiple death fires in homes start from discarded smoking materials. Figure 3.3 shows that 54% of the multiple-death residential fires started in bedding, upholstery or clothing. It is disconcerting in Figure 3.3 that 26% of the fires initially ignited bedding while only 12% of fires shown in Table 3.9 started in the bedroom. There seems to be an anomaly. A more recent study (Berl, Fristorm, Halpin 1975) conducted of 172 fatal fires by APL/JHU indicated a much higher percentage of fires originating in the bedroom (see Table 3.10). Surprisingly, this study indicated approximately the same "causes" of fatal fires (Table 3.11).

## BUILDINGS

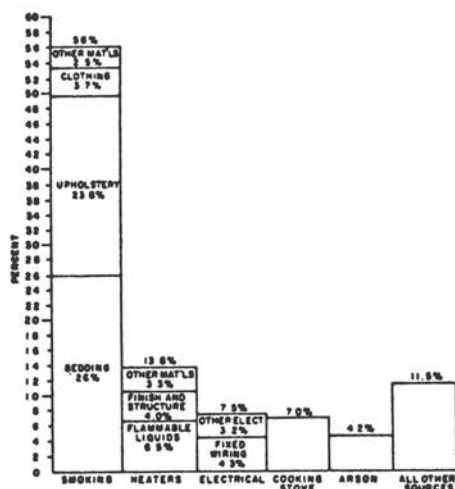

Figure 3.3. Causes of fatal residential fires.

Table 3.10. Room of Origin – APL/JHU Fire Fatality Study Sept. 1971-Dec. 1974 (Berl, Fristrom, Halpin 1975) (172 Fires)

Bedroom	49%
Living room	22
Kitchen	7
Basement	6
Dining room	1
Other	12
Unknown	3
	<u>100%</u>

Table 3.11. Cause of Fatal Fires as Indicated by Fire Investigators for the Time Period September 1971-December 1974 (172 Fires)

"Smoking"	52%
Careless use of matches	7
Flammable liquids	8
Heating equipment	6
Electrical malfunctions	4
Careless use of candles	2
Other	11
Unknown	10
	<u>100%</u>

## DEVELOPMENT AND ANALYSIS OF FIRE SCENARIOS

Recently, the National Fire Prevention and Control Administration published the findings of a household fire survey designed to determine the causes of all fires in the United States, including minor fire incidents not generally reported to the fire service (NFPA 1976). Since many of these fires do not result in fatalities, it is not surprising that these statistics of When, Where, and How Residential Fires Start are significantly different.

### 3.2.3 Property Loss from Fires

Each year NFPA compiles an estimate of building fire causes and losses in the United States. These estimates describe the overall fire problem in general terms and are useful in identifying those components of the fire problem that are responsible for the largest number of fires or amount of property loss. Annual averages for the five year period 1970-74 are shown in Table 3.12 and Table 3.13.

*Table 3.12. U.S. Building Fire Causes (Annual Averages of Five-Year Period 1970-74) (NFPA 1976)*

<u>Most Frequent Causes</u>	<u>Number of Fires</u>
Electrical	160,980
Smoking, Matches	114,420
Heating, Cooking Equipment	89,520
Incendiary, Suspicious	86,660
Open Flames, Sparks	72,140
Children and Matches	66,760
Flammable Liquids	62,460
Lighting	20,640
Chimneys, Flues	20,480
Spontaneous Ignition	14,180

*Table 3.13. U.S. Building Fire Losses by Occupancy (Annual Averages of Five-Year Period 1970-74) (NFPA 1976)*

<u>Most Common Occupancies</u>	<u>\$ Loss</u>	<u>Number of Fires</u>
1-2 Family Dwelling, Other than Apartments	671,880,000	578,820
Apartments	200,040,000	117,840
Hotels, Motels	45,160,000	19,380
Schools, Colleges	95,900,000	23,900
Churches	26,500,000	4,060
Farm Buildings	114,920,000	32,100
Stores, Office, Restaurants	426,880,000	88,300
Garages, Service Stations	78,520,000	40,640
Warehouses, Grain Elevators	165,740,000	12,100
Industrial Property	402,700,000	43,400

## BUILDINGS

These figures represent the major areas of building fire losses. A complete compilation for 1975 is shown in Tables 3.14 and 3.15 below.

**Table 3.14. Estimated United States Building Fire Losses by Cause, 1975**

*These estimated figures are intended to show the relative order of magnitude of fire losses by cause, and to indicate year-to-year trends. While they are reasonable approximations based on experience in typical states, they should not be taken as exact records for each class. The figures by themselves do not show the relative safety in use of various types of materials, devices, fuels, or services, and they should not be used for that purpose. Reproduction of this table in whole or part, is authorized only with written permission from the Association and with the following identification of figures: National Fire Protection Association estimates.*

Cause	Number of Fires		Estimated Loss	
Heating and Cooking Equipment .....		165,600		\$ 222,900,000
Defective or misused equipment .....	91,000		\$144,700,000	
Chimneys and flues .....	15,600		23,200,000	
Hot ashes and coals .....	12,300		2,000,000	
Combustibles near heaters and stoves .....	46,700		52,900,000	
Smoking-Related .....		137,800		166,800,000
Electrical .....		150,500		358,100,000
Fixed wiring and distribution equipment .....	78,400		193,400,000	
Power-consuming appliances .....	72,100		164,700,000	
Trash Burning .....		155,500		5,000,000
Flammable and Combustible Liquids .....		61,900		63,400,000
Open Flames and Sparks .....		85,500		175,900,000
Sparks and Embers .....	17,400		10,200,000	
Welding and Cutting .....	14,600		56,400,000	
Sparks from machinery .....	15,100		26,100,000	
Thawing pipes .....	7,900		22,500,000	
Other open flames .....	30,500		60,700,000	
Lightning .....		14,200		36,100,000
Children and Fire .....		64,200		116,900,000
Exposure .....		34,100		21,800,000
Incendiary and Suspicious .....		144,100		633,900,000
Spontaneous Ignition .....		11,000		21,900,000
Gas Fires and Explosions <sup>1</sup> .....		9,500		34,900,000
Fireworks and Explosives .....		3,900		41,100,000
Miscellaneous Known Causes .....		89,300		288,700,000
Unknown Causes .....		137,300		1,249,300,000
<b>TOTAL BUILDING FIRES .....</b>		<b>1,264,400</b>		<b>\$3,436,600,000</b>

<sup>1</sup> Does not include fires originating in heating and cooking equipment.

These figures indicate the number of building fires at about 1,200,000 per year, resulting in a property loss that has grown to almost \$3.5 billion per year. Coupled with this information is the magnitude of new building construction in the United States each year (Table 3.16). These figures are a necessary base for estimating the impact of any new fire safety recommendations.

### 3.2.4 Summary

Obviously the above statistics clearly indicate the magnitude of the building fire problem in the United States. The building sector offers the greatest challenge to improved fire safety through the use of improved materials, better designs, and earlier detection.

## 3.3 Fire Scenario Development

### 3.3.1 Guidelines for Development

This section is primarily concerned with recognition and discussion of the im-

DEVELOPMENT AND ANALYSIS OF FIRE SCENARIOS

Table 3.15. Estimated United States Fire Losses by Occupancy, 1975

These estimated figures are intended to show the relative order of magnitude of fire losses by occupancies. While they are reasonable approximations based on experience in typical states, they should not be taken as exact records for each class. Any reproduction of these figures should be identified as follows: National Fire Protection Association estimates

Occupancy	Number of Fires	Estimated Property Loss
<b>Public Assembly Occupancies</b>	41,500	\$ 173,000,000
Amusement centers, ballrooms, auditoriums, exhibition halls	3,400	\$ 18,700,000
Churches	4,700	32,100,000
Private clubs	3,600	18,400,000
Restaurants, taverns, nightclubs	23,700	62,400,000
Theaters	1,300	12,500,000
Other places of public assembly	4,900	28,900,000
<b>Educational Occupancies</b>	34,300	130,000,000
Schools, through twelfth grade	26,900	110,900,000
Other educational occupancies	7,400	19,100,000
<b>Institutional Occupancies</b>	30,200	40,100,000
Rest and nursing homes	9,300	6,400,000
Hospitals	15,700	22,200,000
Other institutional occupancies	5,200	11,500,000
<b>Residential Occupancies</b>	916,000	1,389,000,000
One- and two-family dwellings	677,100	853,500,000
Apartments	158,500	337,900,000
Hotels and motels	28,200	68,900,000
Mobile homes	28,100	72,900,000
Other residential occupancies	24,100	55,800,000
<b>Mercantile Occupancies</b>	82,600	444,600,000
Appliance and furniture stores	4,700	39,500,000
Clothing stores	4,600	23,900,000
Department and variety stores	5,500	57,600,000
Drug stores	3,100	8,200,000
Grocery stores and supermarkets	7,200	40,300,000
Motor vehicle sales and repair facilities	11,400	48,300,000
Offices and banks	17,500	57,900,000
Service stations	6,300	15,100,000
Other mercantile occupancies	22,300	153,900,000
<b>Basic Industry, Defense and Utility Occupancies</b>	6,500	104,000,000
Electric power plants	2,900	37,200,000
Mines and mineral product plants	1,300	43,400,000
Other basic industry occupancies	2,300	23,400,000
<b>Manufacturing Occupancies</b>	51,700	641,100,000
Beverage, tobacco, and essential oil plants	1,100	6,900,000
Drug, chemical, paint and petroleum plants	5,300	162,000,000
Food product plants	4,900	68,000,000
Laundry and dry cleaning plants	4,300	7,900,000
Metal and metal product plants	5,700	89,300,000
Paper and paper product plants	3,900	22,900,000
Plastic and plastic product plants	3,600	29,000,000
Printing plants	1,200	5,300,000
Textile and textile product plants	3,900	39,800,000
Wood and wood product plants	3,200	57,400,000
Other manufacturing occupancies	14,700	132,600,000
<b>Storage Occupancies</b>	64,500	442,400,000
Barns and stables	18,200	106,100,000
Bulk plants and tank farms	1,400	63,400,000
Garages and residential parking	21,700	34,100,000
Grain elevators	2,200	55,400,000
Lumber and building materials storage	1,200	27,700,000
Sheds and farm outbuildings	11,900	37,000,000
Other storage buildings	7,900	118,700,000
<b>Other Buildings (not included above)</b>	37,100	72,400,000
<b>TOTAL BUILDING FIRES</b>	1,264,400	3,436,600,000
<b>Nonbuilding Fires</b>	1,840,800	734,000,000
Standing crops	22,800	38,400,000
Forests	128,000	180,100,000
Grass, brush, rubbish outside of building	1,056,000	21,000,000
Transportation equipment	634,000	494,500,000
<b>TOTAL NUMBER OF FIRES</b>	3,105,200	\$4,170,600,000



## BUILDINGS

*Table 3.16. Floor Space of Buildings Construction in United States  
(millions of sq. ft.) (F.W. Dodge Div. 1975)*

	1972	1973	1974
Residential	2,705	2,574	1,693
Commercial	643	717	614
Industrial	211	293	246
Educational	156	156	179
Hospital	84	76	79
Other	161	197	193
Total	3,960	4,013	3,004

portant elements about a fire which ideally belong in a scenario. Recognizing that virtually all actual fire investigations are handicapped by the absence of trained observers, especially at the early stages of the fire, frequently events must be pieced together from fragmentary evidence. Nevertheless, it is useful to indicate what information is desirable. In some cases, one may want to set up a simulation of a fire scenario: to determine whether or not what one thinks happened could really happen, to instrument the fire and obtain quantitative data on critical fire dynamic elements, to investigate changes in the scenario from design modifications or the substitution of different materials, etc. Certainly, a knowledge of the relevant factors is essential.

### 3.3.1.1 Prefire Situation

Important events in the fire scenario occur long before the ignition source sets the fire in motion. Decisions made during planning, design and building will profoundly affect subsequent events in the fire chain. Therefore, it is essential that adequate attention be directed towards the prefire situation; since, in some instances, the optimum situation may result from action taken long before the fire begins.

The first step in the development of the fire scenario includes the gathering of data such as local building codes that govern materials and processes, plans and specifications, builder and manufacturer records, and inspection records. Attention should be directed toward: the basis for material selection; how and where the materials were to be used; and how materials were installed. Specifically did the materials meet the applicable codes, were they used properly and were they installed correctly? This kind of information is essential to the completeness of any fire scenario.

### 3.3.1.2 Ignition Source

In general, the fire starts with an ignition source. In perhaps the majority of cases, this is an initially "wanted" combustion which leads to an "unwanted" fire. Examples are the discarded cigarette, the soldering torch, the defective furnace, the

stovetop burner, the fireplace ember, etc. Another large class (initially "unwanted") of sources involves failures of electric circuits of equipment. Numerous other special "unwanted" causes such as lightning, static sparks, spontaneous combustion, may also be listed.

Often, sufficient information about the ignition source to characterize it quantitatively is needed. This is because in many cases the ignition of the target fuel is marginal, i.e., the ember falls on the rug but ultimately may self-extinguish. The blowtorch impinges on the plywood panel for a second but only chars it. Unless the details of the characteristics of the ignition source is known, one cannot say when a fire will result.

The primary parameters of an ignition source are:

- maximum temperature;
- energy release rate;
- time of application to target;
- area in contact.

On a more sophisticated level, in some cases the details of the heat transfer from the source to the target may be needed. Some combination of conduction, convection, and radiation may be involved. The degree of air motion or turbulence may influence spontaneous ignition of a heated vapor rising from a surface. Access to oxygen is important; for example, a target immersed in hot combustion products may not ignite because oxygen is excluded.

Importantly, for solid polymers which are not readily ignitable, a "strong" ignition source will generally ignite the target while a "weak" one will not. The "strength" of the source depends on the energy flux and on the time of application to the target, and sometimes simply on the product of these two. (see Vol. 4 Sec. 3.3.2).

### 3.3.1.3 Ignited Material

The first material to be ignited is generally important in the scenario. The question is, given an exposure to an ignition source, how does the probability of ignition relate to the properties of the target material? In many cases, these properties are crucial in determining whether ignition occurs. Hence, a detailed description of the relevant target material properties is vital to the scenario.

If the target is a flammable liquid, its ignitability will depend on whether it is in the form of a stationary pool, a foam, a mist, or a spray. Assuming it is a stationary pool, its initial temperature is critical. If this temperature is below the flash point, ignition will occur only after sufficient heating to bring a substantial portion of the liquid to the fire point. If the initial temperature is above the fire point, ignition of the fuel vapors above the pool will occur immediately and the pool easily sustains burning.

In most fire scenarios, the target material is solid. The ignitability of a solid

depends not only on its chemical composition but also on the energy balance at the surface (including radiation), on its thickness and thermal properties, and on its configuration.

In considering the chemical composition of a target material, the following is especially relevant: 1) The basic material may contain small percentages of additives (e.g., fire retardants) or impurities which may have major effects on ignitability. 2) If the material is hygroscopic, like cotton, the initial moisture content will vary over a wide range depending on preignition humidity; this has an important influence on ignitability. 3) If the material contains several major constituents, e.g. flexible polyvinyl chloride that contains a large portion of plasticizer, the ignitability depends on the more volatile constituent, in this case the plasticizer. 4) The target will frequently be composite in nature, consisting of an outer skin material and an underlying material, either of which may contribute to ignitability — or *per contra*, may retard ignitability, e.g., the duPont "Vonar" system for fire protection of mattresses.

The importance of the energy balance at the surface is shown by attempting to ignite a single piece of wood, say a two-by-four. No self-sustained burning will result (unless the ignition source is applied for a very long time, so that the average temperature of the wood reaches about 320°C). However, a burning match between two vertical two-by-fours placed close together will give self-sustained burning. In contrast to the two pieces of wood, the single piece cannot continue to burn because of the high rate of radiant energy loss from the charred hot surface to the cold surroundings. This effect is less important for materials that burn at lower surface temperatures, such as non-charring thermoplastics. Radiant input from the igniting source can also be important, so the absorptivity of the target material is a significant factor in such a case.

The thickness and thermal properties of a material are vital parameters for ignition time. This becomes decisive in the scenario if the heat flux is of relatively short duration. A distinction must be made between "thermally thick" and "thermally thin" materials. (see Vol. 4, Sec. 3.3.2). The time to ignition for a "thermally thick" material is independent of the thickness and is controlled by the "thermal inertia," defined as the product of the thermal conductivity and the heat capacity per unit volume. For a "thermally thin" material, the ignition time is proportional to the product of thickness and heat capacity per unit volume. (Fabrics are generally in this category). Whether the material behaves in a "thermally thick" or "thermally thin" manner depends not only on the thickness but also on the heating rate, the heating time, and the "thermal diffusivity," which is the ratio of thermal conductivity to heat capacity per unit volume.

In the case of a thin flammable material (carpet, paneling, etc.) in thermal contact with an underlying material, the underlying material can influence the ignitability to the extent that it acts as a heat sink.

The configuration of the target material can also be of great importance. The

foregoing discussion has implied a one-dimensional geometry. In reality, ignition tends to occur more readily in a crevice or fold or at an edge or corner, than in the middle of a flat surface.

### 3.3.1.4 Flaming or Smoldering Combustion

Some combustible materials may burn either in a smoldering mode, like a cigarette, or a flaming mode. Also, a material may smolder for a certain length of time and then spontaneously burst into flame.

In general, only solids with very low thermal conductivity, such as porous solids, or thin solids not in contact with a heat sink, such as a suspended cotton thread or a free-standing piece of paper, can smolder. (A sofa cushion made of polyurethane foam rubber under a synthetic fabric cover can smolder). Smoldering is characterized by a much lower fire spread rate than flaming combustion.

It is important to recognize that in smoldering: a) the smoke or gases produced may permit detection of the fire at an early stage; b) the pyrolysis products may be toxic; and c) transition to flaming after a long period of smoldering may produce a very rapidly growing flaming fire, because of the preheating of fuel and accumulation of combustible gases which occurred during the smoldering period.

It is known that the composition and character of smoke produced in flaming combustion are different from that produced by smoldering combustion of the same fuel. This is shown by the differing response characteristics of smoke detectors. Consequently, this must be taken into account when selecting smoke detectors.

Smoldering may continue for a very long time. For example, a barrel of sawdust might smolder for more than 24 hours. Therefore, scenario analysis should consider the possibility of a long time lag between ignition and active flaming.

The burning of charcoal is generally referred to as glowing combustion rather than smoldering. The importance to the fire scenario is that cellulosic materials, after the flaming combustion is finished, continue to glow for a substantial time as the residual charcoal is consumed. During this time, the possibility of a resurgence of the fire exists.

Also, when a gaseous extinguishing agent such as carbon dioxide or a halocarbon vapor is applied to a fire, it may stop the flaming combustion, but a smoldering combustion may continue (deep-seated fire) and after a time the extinguishing vapor may dissipate and the flame rekindles. Thus a "one-shot" gaseous extinguishing system may not assure protection unless the fire is held in check long enough for effective manual response.

### 3.3.1.5 Fire Spread

#### 3.3.1.5.1 General

Unless a person is wearing or sleeping on the originally ignited item, the fire is not likely to do much damage until it has grown by spreading some distance from the point of ignition. The rate of spread is very important in the scenario, because it

defines the time after ignition for the fire to reach a dangerous size. The "dangerous size" may relate either to the rate of generation of toxic and smoky products or to the difficulty of extinguishment. The ability to detect, fight, or escape from the fire depends on the time to reach a dangerous size, and hence on the spread rate.

Fire may spread either from one contiguous fuel element to the next, or by jumping across a gap from the initially ignited material to a nearby combustible item. These two cases are discussed separately.

### 3.3.1.5.2 Fire Spread Over the Initially Ignited Material

The rate of flame spread over a solid surface in the horizontal or downward direction is often quite slow, sometimes as little as one inch per minute. However, if the material is "thermally thin" (see Vol. 4 Sec. 3.3.3), or has been preheated by radiation or convection from hot combustion products, the flame can spread quite rapidly. If the fuel is so arranged that upward propagation can occur, it will occur very rapidly and at a progressively accelerating rate. If the fuel is arrayed as a lining of a corridor or duct, with the air supply coming from one end, and the combustion products exiting from the other end, the fire will spread rapidly from air entrance toward the exit until it penetrates sufficiently far into the duct so that the oxygen is exhausted. It will then stop spreading until the originally burning fuel is consumed, after which it will move downstream. In this situation, the effect of ventilation is controlling.

Indeed, for any fire burning in a compartment with limited air supply, the rate of spread will decrease as the air becomes vitiated by combustion products. However, spontaneous breaking of windows or deliberate actions of firefighters to improve visibility by ventilating the fire will have an accelerating effect on spread rate.

Fire spread over a liquid is relatively slow when the liquid is well below its flash point, but possibly a hundred times as rapid if the liquid is above its flash point. For liquids below their flash point, fire induced motion within the liquid importantly affects the spread rate.

### 3.3.1.5.3 Fire Spread to Secondary Material

If the originally burning material is separated by a gap from the nearest secondary combustible and the flame does not impinge directly on this secondary material, the fire will die out after the original material is consumed, unless by some mode the fire can spread across the gap. The possible modes will be considered.

- Radiation. The fire may radiate directly to the target. Or, the fire may convectively heat the ceiling and upper walls, which then radiate to the target. Or, hot smoky gases accumulating under the ceiling may radiate onto the target. Or, a combination of these effects may occur.

In any case, the effect of the radiation is to preheat the secondary material until it pyrolyzes, emitting flammable vapors. At this point two possibilities exist. Either the secondary surface may ignite, or a sufficient concentration of a flammable vapor mixture is achieved so that the original flame may spread through this vapor cloud to the secondary material.

- **Burning Droplets.** Other modes exist for fire spread across a gap. If the original burning object is a thermoplastic, it will melt, and burning droplets may fall and ignite secondary fuels they may encounter.

- **Mechanical Fire Transfer.** If the original burning object is mechanically weakened and falls over, the collapse can provide a means of fire spread. Similarly, mechanical action associated with an ineffective attempt to extinguish the fire may lead to its spread.

- **Spattering.** In the case of overheated grease in a kitchen pan fire, the burning grease may spatter and self-propelled droplets may spread the fire. Or, an ember from a fireplace log or other burning object may be propelled several feet by pyrolysis gases and cause secondary ignition.

- **Firebrands.** Finally, fires may be spread by wind-borne firebrands. The winds may be generated by the convection plume of the fire itself. Firebrands might be associated with conflagrations in cities, or any outdoor fire in a high wind.

### **3.3.1.6 Evolution of Smoke and Toxic Gases**

#### **3.3.1.6.1 General**

Smoke and toxic gases are important to the fire scenario in at least three ways. First, they may provide a means of early detection of the fire. Second, they interfere with visibility and, hence, with escape or with firefighting. And, third, they have psychological and physiological effects on humans, including confused thinking, incapacitation, and death. In most instances, deaths in building fires are a result of the toxic combustion products and not a result of the heat and flames from the fire.

In addition to these major aspects, other special features of smoke and fire gases may exist. The smoke may be important in the fire spread process by virtue of its radiation emission or absorption. And, substantial property damage may be caused by smoke or corrosive combustion products.

#### **3.3.1.6.2 Automatic Detection (See also Section 6.2.2.3)**

Relative to automatic detection, the first consideration is the rate of smoke movement from the fire source to the detector. Under a no-fire condition, the air movement in a room or compartment is determined by any existing forced convection for heating, air-conditioning, or odor-removal purposes, or by open doors and windows, together with external wind conditions, or by free-convective motions driven by heat sources. For very small fires, the buoyancy effect of the fire heat will be negligible and the smoke will follow the existing air circulation paths. When the fire becomes larger than some critical size, the hot fire plume will rise to the ceiling and then flow under the ceiling, creating an entirely new circulation path in the room. If, before the fire, the upper portion of the room were warmer than the lower portion, as would normally be the case for either a heated house in winter or a house on a hot summer day, then temperature-induced stratification will exist

and smoke may rise halfway up and then spread laterally. For early detection of fires, the foregoing factors determine detector response.

Another consideration is the response of the automatic detector to the smoke. This depends on the time-dependent concentration and particle size of the smoke at the detector, the velocity of smoke past the detector, orientation of the detector to the smoke flow, the smoke entry characteristics of the detector chamber, the operating principle of the detector, as well as the sensitivity of the detector circuit, battery voltage, etc. It is especially important to note that different combustibles, or the same combustible flaming or smoldering under different ventilation conditions, produce smoke of different particle size and, hence, detection characteristics. It is also known that smoke may "age" after it is formed, i.e., agglomeration of smaller particles into larger ones will occur with consequent effect on ease of detection.

#### **3.3.1.6.3 Visibility**

The optical scattering properties of the smoke depend strongly on particle size as well as concentration; the vision-obscuring aspects which interfere with escape or firefighting are strongly dependent on the type of combustible and mode of combustion. For example, incomplete burning of polystyrene or rubber produces large soot particles capable of obscuring vision even at low concentrations. The lachrymatory effects of gases such as aldehydes or acids associated with the smoke particles have been shown to be important in interfering with vision.

The visibility at floor level will generally be much better than at higher levels in the room, so the possibility of crawling to safety is important. The height at which exit signs should be located is relevant here. If sprinklers operate, both the cooling and entrainment effects tend to bring the smoke closer to the floor. Also, fog which may result from the employment of sprinklers will interfere with vision.

#### **3.3.1.6.4 Toxic Effects**

Smoke and toxic gases are far more important than heat and flame as a cause of death in building fires; carbon monoxide is the chief toxicant, according to our present knowledge. However, other specific substances which may be present in the smoke, such as acrolein, hydrogen cyanide, hydrogen chloride, hydrogen fluoride, carbon dioxide, etc., may be very important in certain cases and may have synergistic effects. (see Volume 3 for a more complete discussion).

The critical survivable concentration of toxicant depends on the time of exposure, which, when escape is not possible, depends on the history of the fire as discussed in other sections. Also, combined effects of toxicants with heat, excitement, loss of vision, etc., are believed important in determining survival, as is the original conditions of health of the subject, and previous intake of alcohol or drugs.

Confused mental processes induced by toxicants may be of critical importance to survival in cases where the subject has to make a rapid and correct decision on proper escape tactics.



### 3.3.1.7 Extinguishment

At some point in the development of each scenario, either manual or automatic extinguishment activity may commence. This may involve smothering the fire, or applying water or other agent. The techniques of extinguishment are outside the scope of this study. However, the effectiveness of extinguishment will depend on the burning characteristics of the polymeric combustible. If the fire has become too large or is growing too rapidly at the time extinguishment is attempted, the fire will not be controlled.

Accordingly the rate of fire spread and the maximum rate of burning of the fully involved combustible are important parameters. For manual firefighting, a critical factor is how closely can the firefighter approach the fire, and indeed will smoke prevent him from determining where the fire is? If he has a hand-held extinguisher of given capacity, will it be enough to do the job? When automatic sprinklers are present, there is generally no problem unless the fire is shielded from the sprinklers (i.e., in an unsprinklered closet) or unless it is a high-intensity fire (i.e., polystyrene foam products stored 15 feet high), in which latter case the key variable is sprinkler design spray density.

### 3.3.1.8 Flashover

Flashover is a critical transition phase of a fire in a compartment. In general, it will be in a ventilated compartment, since otherwise the fire will tend to smother itself before the flashover stage is reached. Prior to flashover, a local fire is burning in the compartment, the rate of which is determined by the extent of flame spread to that time. After flashover, all flammable contents in the compartment are burning or rapidly pyrolyzing, flames are projecting out the door or window and the burning rate within the compartment is determined by the rate of ventilation and/or the total exposed fuel area. Flashover often occurs very suddenly, within a time interval of a few seconds, and is characterized by very rapid fire spread throughout the compartment, with flames violently rushing out the door or window.

Whether flashover can occur in a compartment depends on the size and shape of the room, the ventilation available, the intensity of the initial fire, and the quantity and disposition of secondary fuels. If flashover can occur, the time required for its occurrence will depend on the foregoing variables plus the thermal inertia of the room, especially the ceiling. A fire in a typically furnished room will require five to twenty minutes after flaming ignition to reach flashover (Figure 3.4).

In the pre-flashover period, the upper portion of the room is filled with hot, smoky, oxygen-deficient gases. The lower portion contains relatively cool, clean air coming from the door or window. At some intermediate level, perhaps two feet under the ceiling, there may be both sufficient oxygen and sufficient heat so that target fuels at this height could most readily ignite. Drapes or curtains would be examples of materials in this region.



## BUILDINGS

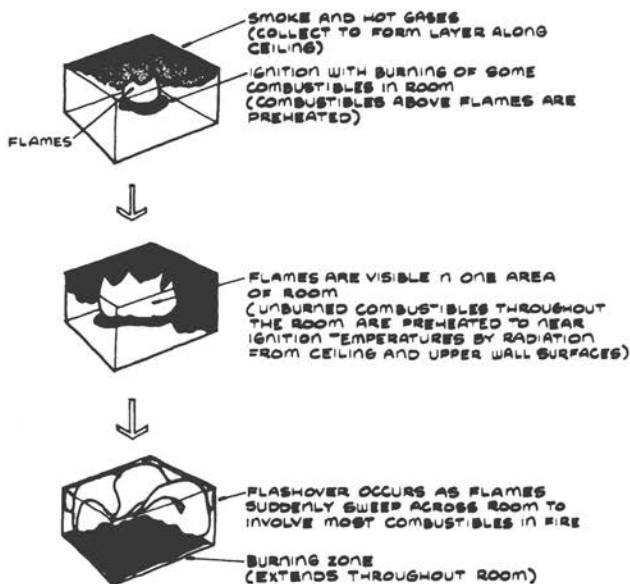

Source: M. David Egan, CONCEPTS IN BUILDING FIRE SAFETY, p.10, John Wiley & Sons, Inc., New York, NY, 1978

Figure 3.4. Flashover.

Radiation is probably of major importance in flashover. Thus, the infrared emission, absorption, and reflection coefficients of objects and smoke in the compartment are highly relevant.

The larger the volume of a compartment, the less likely it is that a fire of given size will cause flashover. Data on simulated room fires indicates that, for a 12' X 12' X 8' room, a fire consuming 2 pounds of fuel per minute could produce flashover in about 20 minutes, while if the combustion rate were twice as high, namely 4 pounds per minute, flashover would occur in 1.5 minutes. Thus, one would suspect that even a very large, sparsely furnished room could flash over, if a high rate of initial burning is achieved, because the time to flashover is extremely sensitive to rate of heat release. The fire in the BOAC passenger terminal at J. F. Kennedy Airport, New York, in 1970, illustrates a fire in a large space with low fuel loading but presumably very high heat release rate because of the plastic foam padding on lounge chairs, which apparently developed in a short time to a flashover condition.

### 3.3.1.9 Spread to Adjacent Compartments and Catastrophic Failures

Fire resistant compartmented buildings are designed with the expectation that a fire in any one compartment will be confined by the building structure itself so that

either the fire is extinguished or the fuel is exhausted before the fire breaks through. Interior partitions, fire doors, etc., are subject to building codes specifying that the partition can maintain its integrity for an appropriate time, one hour, two hours, etc., depending on circumstances. Hence, the scenario should include information on the fire endurance rating of the relevant structural elements.

Assuming that the building itself is fire resistant, the fuel loading<sup>2</sup> influences the duration of the fire, once it has grown large enough to become ventilation-controlled. As a rough rule of thumb, there is an endurance requirement of about 0.1 hour for each pound per square foot of fire load. (This assumes certain typical ventilation rates). The fire load may range from a few pounds per square foot in lightly furnished occupancies to an order-of-magnitude higher fire load in storage occupancies.

The endurance requirements are based on the assumption that the fuel is primarily cellulosic; however, if it is primarily a polyolefin or hydrocarbon-based rubber, the stoichiometric air requirement per pound of fuel will be up to three times as large. The heat release per pound of fuel will also be much higher; a ventilation-limited polyolefin fire may burn differently than a cellulosic fire.

Of course, if the fire compartment has openings to other sections of the structure, such as open doorways, ventilating ducts, improperly firestopped or inadequately sealed openings in walls, etc., these are critical elements in the scenario. Even if the flames were confined to the compartment of origin, the spread of smoke and toxic gases throughout the structure could have catastrophic effects.

If the fire is capable of heating structural elements of the building to a failure point (e.g., steel above 1000°F), then a collapse of the structure may occur. Even at lower temperature, thermal expansion of steel may cause structural failure. The thickness and integrity of insulation on structural elements thus becomes important to the fire scenario.

Local structural collapse within a sprinklered building may cause breakage of the sprinkler piping and consequent escalation of the fire damage.

For multi-level structures, it is especially important to prevent the spread of fire progressively upward from one level to the next higher. Key items to consider in this type of scenario are: ventilation passages; utility passages; fire endurance of ceiling, stairwells, or elevator shafts; and flame projecting from a window so as to cause ignition through the window of the floor above.

#### **3.3.1.10 Spread to Other Structures**

If a structure becomes completely involved with fire, a finite probability exists that adjacent structures will ignite. Ultimately, a conflagration involving a large area may result. Propagation could occur by radiation by firebrands, or by wind-aided flame impingement.

---

<sup>2</sup> Expressed as pounds per square foot.

Potentially critical factors in the fire scenario are: magnitude and direction of the wind; separation distance between structures; flammability of roofing material; ignitability by radiation of curtains inside windows facing fire; combustible trash in alleys between buildings; and propulsion of burning debris after building collapse or explosion.

Spread to adjacent structures occurs at a sufficiently late stage of a fire that firefighters will generally be present. Wetting down of adjacent buildings is extremely valuable in preventing spread to other structures. Conversely, if the fire is simultaneously burning in many areas, as could be the case for a major brush fire, fire caused by civil disorders, or after military incendiary attack, firefighting capability will probably be inadequate. The degree of spread will depend on the intrinsic "hardness" of the structures involved.

Similarly, if fire is accompanied by an earthquake or a strong explosion, water mains will probably be broken and firefighting will become ineffectual. The spread will again be limited by the intrinsic "hardness" of structures involved, which is material-dependent.

### 3.3.1.11 Essential Fire Scenario Elements (Check List)

A scenario should cover as many as possible of the following points:

- (a) The pre-fire situation.
- (b) The source of the ignition energy should be identified and described in quantitative terms.
- (c) The first material ignited should be identified and characterized as to chemical and physical properties.
- (d) Other fuel materials that play a significant role in the growth of the fire should be identified and described.
- (e) The path and mechanism of fire growth should be determined. Particular attention should be given to fuel element location and orientation, ventilation, compartmentation, adjacent structures, and other factors that affect fire spread.
- (f) The possible role of smoke and toxic gases in detection, fire spread and casualty production should be determined.
- (g) The possibility of smoldering combustion as a factor in the fire incident should be considered.
- (h) The means of detection, the time of detection, and the state of the fire at the time of detection should be described.
- (i) Defensive actions should be noted and their effect on the fire, on the occupants, and on other factors should be described.
- (j) Interactions between the occupants of the building and the fire should be detailed.
- (k) The time sequence of events, from the first occurrence of the ignition energy flux to the final resolution of the fire incident, should be established.

The scenario should permit generalization from the particular incident described. It should provide a basis for exploration of alternate paths of fire initiation and growth and for analysis of the effect on fire safety performance of changes in materials, design, and operating procedures. When used in this way, the fire scenario can be an effective tool in increasing fire safety by increasing man's capability to visualize and comprehend the events.

### 3.3.2 Capsule Scenarios

No two fires are alike in all their details; however, all have certain elements in common which permit a systematic study of fires and lead to generalized rules for increased fire safety. All fires have a cause; their initial growth is determined by the physical parameters of the system, and these parameters together with external control measures intervene to limit the growth of the fire and determine the extent of loss. In this section a variety of brief scenarios, is presented, derived from real fire incidents in which polymeric materials played a significant role, to illustrate the diversity of building fires and to show the commonality that permits a scientific approach to fire safety. In preparing these illustrative scenarios, attempts were made to address the following areas: prefire environment, ignition source, material first ignited, other significant material involvement, fire spread, method of detection, extinguishment and extent of loss. Additional fire scenarios from specific real-life incidents can be found in the National Fire Protection Association (NFPA) publication *Fire Journal* (published six times per year) and in special publications of NFPA dealing with fires in various residences, e.g. one-and-two family dwellings (NFPA 1975), mobile homes (NFPA 1975b), and nursing homes (NFPA 1972).

#### 3.3.2.1 Residential Buildings

- Two couples had been playing cards in the downstairs recreation room of a two-story frame house. At about midnight the visiting couple left and the residents went to bed in an upstairs bedroom. At approximately 2:00 A.M. a neighbor saw flames at the recreation room window and called the fire department. He then attempted to rouse the occupants of the burning house but received no response. The fire department responded within five minutes and found the recreation room fully involved. The fire, which had not spread beyond the recreation room, was quickly extinguished. The occupants were found in their bedroom, both dead. The man was lying back on the bed with his feet on the floor; the woman was at the bedroom door. Smoke stains on the wall indicated that smoke was carried into the upper part of the room by the air conditioning system and accumulated down to a level of four feet from the floor. Examination of the recreation room revealed that an upholstered sofa was almost completely destroyed, draperies at the windows had burned, igniting an adjacent plywood panelled wall, and a mineral acoustic tile ceiling was badly discolored but had not contributed to the fire. The wall-to-wall carpeting was burned in the neighborhood of the sofa and draperies but had not

## BUILDINGS

contributed to the spread of the fire. It is probable that a discarded cigarette, left behind at the end of the card game, ignited the sofa which smoldered for some time, producing large quantities of smoke and toxic gas, before bursting into flame. The limited extent of fire damage indicated that flaming combustion had been in progress for only a short time before the fire was extinguished. Death was by carbon monoxide poisoning.

- After a late evening party, ash trays were emptied and other trash was collected in a plastic trash bag. The trash was placed in a plastic trash can in the attached garage of a single family home. The occupants retired shortly thereafter. About an hour later they were awakened by the alarm from a smoke detector located in the central hallway of the house. Smoke odor was evident. Upon investigation, smoke was seen entering the kitchen around the door leading to the garage. The door was carefully opened, and flames were observed in the garage. The door was closed and the fire department was called. When they arrived, the garage was fully involved and smoke and flames were coming out of a window on the side away from the house. The fire was quickly extinguished. A fire-resistant wall had prevented spread into the house and, aside from minor smoke damage, damage was limited to the garage. A burning cigarette had ignited trash in the trash can. The can melted, collapsed, and the plastic material of the can caught fire. The fire spread to adjacent trash cans and then to other combustibles in the garage.

- A fire started at about 1:30 A.M. in a sixth floor apartment of a twelve story apartment house for the elderly. The cause was unknown, but the occupant of the apartment was known to be a chain smoker. The occupant got out of the apartment but collapsed in the corridor outside, leaving the apartment door open. The body was found near the open door after the fire was extinguished. The building automatic smoke alarm alerted the attendant on duty at the front desk. He took the elevator to the sixth floor to investigate. His body was found later in the sixth floor elevator lobby just in front of the elevator. At 1:45 the fire was reported to the fire department by telephone from a neighboring apartment building. When they arrived they found that the fire had spread from the room of origin down the corridor over the synthetic polymeric carpet. A one and one half inch gap for ventilation under the doors of other apartments allowed limited fire spread over the carpet into these apartments and permitted smoke and gas penetration. In addition to the occupant of the room of the origin and the attendant, five persons died of carbon monoxide poisoning in their apartments on the sixth floor. The floor-ceiling construction prevented spread of the fire to other floors.

- The fire started when sparks or fire brands ignited the tufted-pile acrylic yarn carpet in front of the fireplace. This type of carpeting covered the living room, dining room and hall floors. The owner, who had been working in the adjoining dining room when the fire started, tried at first to beat out the fire, but melting plastic severely burned his hands. He then awoke his wife and told her to get the children out of the house and ran to the bedroom for a blanket with which to try

to smother the fire. Upon returning to the living room he found the fire spreading rapidly across the carpet. He shut several interior doors, telephoned the fire department, and left the house. The first firefighters found the living room flashed-over. Since the living and dining rooms were sparsely furnished, with plastered walls and ceilings, the major fire load was the carpeting and foam rubber padding.

- The 18-year old son returned around 2:30 A.M. to his wood-frame split level home. The dwelling included three bedrooms and a bathroom on the upper level, a kitchen, dinette and living room on the main level, and a recreation room, bathroom and utility room at the lower level. The boy decided to fix himself something to eat and was cooking on the gas stove when books and papers stored next to the burners on a shelf that was at the same level as the four burners of the gas range ignited. The mother and a younger brother awoke and attempted to extinguish the fire on the counter. Someone ran out of the front door, grabbed the garden hose and tried to connect it to the faucet in the bathroom on the ground level of the building. They could not make the connection to the faucet as there were no threads on the fixture. At this point the fire was spreading up the cabinets and the mother pushed the youngest son out of the house and told him to call the Fire Department. The fire spread rapidly throughout the dinette and living-room; a contributing factor to the fire spread was the installation of 3/16 inch paneling throughout the area. The fire continued up the hallway leading to the bedrooms. The fire was confined, controlled and extinguished within approximately twenty minutes of the fire department arrival. All four members of the family who had remained in the house were found unconscious in the second floor master bedroom. All later died. There was no fire or smoke damage to the recreation and utility rooms.

- The fire started in a table-model color television set after the family had gone to bed. It smoldered for a considerable time before erupting into flames. The flames ignited the adjacent wall paneling and floor carpeting. It was discovered by a man out walking his dog. Firefighters found dense smoke on arrival; the fire was quickly extinguished. All five members of the family were found dead on the second floor – overcome by smoke and heat while trying to escape. The set was severely damaged, only the metal case remained.

### 3.3.2.2 Mobile Homes

- While the housewife was preparing a meal in the kitchen of a mobile home, the grease in a frying pan on the stove caught fire. She called for help, but by the time her husband could respond the foam plastic cabinet above the stove was involved. He brought a garden hose from outside, but by this time the flames were spreading over the plywood interior finish and he was unable to enter because of the heat and smoke. The fire department had been called by a neighbor and responded within five minutes. By this time the trailer was completely involved, resulting in a total loss, to the unlucky couple who were left only with their lives.

- A plastic outlet box under the bathroom area had been fastened to a wooden

beam by nails, which had also been driven through a copper wire. The wire short-circuited at the point of nail contact with the wire and ignited the plastic undercoating of the mobile home. The resulting fire flashed across the entire underside of the floor, spread to the wood framing of the mobile home, and eventually broke through the floor in the bathroom area.

- The fire started about 3:00 A.M. in wiring to a water heater, which was in a closet in one corner of the bathroom near the rear of the mobile home. Three girls were sleeping in a bedroom at the end of the home adjoining the bathroom. An air conditioner was running in the living room area at the front of the mobile home. In order to force the cool air toward the children's bedroom, a window fan had been placed in the hallway. When the fire broke out, the draft created by this fan caused the fire to spread through the partition into the girls' bedroom until it reached the outside wall. Aided by very thin, highly flammable, plywood interior finish, the fire then spread back through the bathroom, kitchen and living room, where it was stopped by firefighters. The three girls died.

### 3.3.2.3 Non-residential Buildings

- An electric coffee maker was left on in a ninth floor file room in a high-rise office building. At about 9:30 P.M. the building fire alarm system indicated smoke on the ninth floor. The fire department was called and a building guard went to investigate. On entering the office suite he found a great deal of smoke and flame coming out of the file room door. He closed the outer door and went to meet the firemen. The fire in the file room was quickly extinguished with hose lines. It was found, however, that the fire had penetrated a louvered door into a telephone closet where burning cable insulation was spreading the fire to other floors through the open cable shaft. The fire was confined to the cable shaft and extinguished with difficulty. Several firemen suffered from "smoke inhalation." The ventilation system, which had been switched from a recycle mode to 100% fresh air when the alarm was given, helped to prevent the spread of smoke through the building. It did this by providing a pressure differential adjacent to the fire zone.

- Two construction workers were using a torch to cut holes in the interior wall of an unsprinklered refrigerated warehouse to install a new conveyor. The wall was of steel construction with three inches of sprayed-on plastic foam insulation on the inside. Shortly after the work was started, the workmen observed fire in the interior of the warehouse around the hole they had made. They entered the warehouse through a door and found the insulation burning. One went to call for help while the other attempted to fight the fire with a portable fire extinguisher. When the first one returned to the scene, black smoke was pouring from the door. He was unable to enter the warehouse or locate his companion. The fire department arrived and firemen wearing self-contained breathing apparatus quickly extinguished the fire. The body of the workman who had tried to fight the fire was found near the door. He was unburned. A portion of the insulation had been burned from the wall



but there was no structural damage to the building. Restricted ventilation had limited the growth of the fire.

- A plant manufactured expanded polystyrene egg cartons. The raw material is polystyrene pellets, and the process involves extrusion with a blowing agent followed by thermal forming in presses. The product cartons were packed 200 per polyethylene bag, with 18 bags stacked on a 4' X 4' piece of cardboard, making a 6' high stack. The storage array was 3 stacks high, or 18' high. The storage area was sprinklered at the ceiling level. Ignition was caused by an overhead lighting fixture contacting the stored commodity. The fire burned with such intensity that sprinklers, delivering 0.4 gallons of water per minute per square foot, were unable to control the fire. The fire department arrived in ten minutes but the dense smoke hampered their operation. Three firemen were overcome by fumes from the burning plastic. After three hours of burning under conditions of restricted ventilation, a large portion of the roof over the fire collapsed. This was followed by a rapid growth of the fire, driving the firemen from the building. Molten polystyrene was found on the floor, covering a 10,000 square foot area to a depth of 5 inches. Damage to the building, machinery, and stock totaled \$1.9 million; production was interrupted for 8 months at a cost of \$1.5 million.

A fire of incendiary origin was started in a pile of trash that was separated by a concrete retaining wall from the seating section of an unoccupied sports stadium. No fire protection was available in this open concrete structure. The fire department was called immediately upon discovery of the trash fire. By the time firemen arrived on the scene, the fire had leaped over the wall and ignited the seats which were composed of molded plastic backs and seats in metal frames. The fire spread rapidly, aided by air flow up the sloping sides of the stadium. An entire section of seats was destroyed. The break between sections helped the fire department to contain the fire at that point. Prompt intervention by the fire department prevented the entire seating in the stadium from being destroyed.

- Additional scenarios may be found in Sections 4.5.3 and 4.5.6. These deal with office buildings, restaurants, and nightclubs.

### 3.3.2.4 Custodial Buildings

- A faulty Christmas tree light ignited a plastic tree in a hospital lobby. The fire spread to plastic decorative plants and then to plastic covered foam upholstered furniture. An attendant saw the fire and sounded the alarm. Fire doors prevented the heavy black smoke from traveling to other parts of the building. The fire department responded quickly and extinguished the fire. Fire resistant interior finishes on walls and ceiling and a carpet which passed the current mandatory flammability standard ("pill" test) prevented spread of the fire from the immediate vicinity of the ignition source. Smoke and gas from this small fire would have been a serious threat to the occupants if allowed to spread through the building.

- A group of teenage inmates of a state "training school" barricaded themselves



in a recreation room as a protest against disciplinary policies. The outside exit to the room was locked with a security lock and windows were barred. The room was of non-combustible construction. The inmates piled furniture, including chairs and sofas upholstered with polymeric foam material, against the door leading to the rest of the building. One of the inmates set fire to the furniture to attract attention. They tried to suppress the fire by smothering and beating it out with materials at hand, but were unsuccessful. The fire grew rapidly in the pile of furniture, filling the room with smoke and gas. The fire alarm sounded and help arrived promptly but by the time the door could be forced open the room was completely filled with smoke. The fire department quickly extinguished the fire which was confined to the furniture. One inmate was dead from inhalation of toxic gases and the others required hospitalization. There was no significant structural damage to the building.

● A nursing home was relatively new and was protected with an automatic sprinkler system throughout. A male patient with a history of carelessness in the use of smoking materials was restrained in his chair. The man received matches from a visitor, despite the visitor having been warned by an attendant not to do so. Apparently the man ignited his clothing with the matches. The fire spread over his clothing and into the chair before a sprinkler located overhead operated to confine the fire. Arriving firemen found the room full of smoke and the fire knocked down by the water from the sprinkler. They removed the victim and his two roommates to a nearby hospital. The two roommates were soon released, apparently none the worse for the experience; but the victim died before reaching the hospital. Damage to the buildings and contents was minor.

### 3.3.2.5 Summary

● All of the foregoing fires can be characterized by the following generalized scenario:

- a. Polymeric materials were deployed in a manner conducive to fire development.
- b. An energy source was applied to an easily ignitable fuel element.
- c. The fire grew and spread, consuming fuel and producing heat, smoke, and toxic products.
- d. The fire was detected.
- e. Fire control action was undertaken.
- f. The fire was ultimately extinguished.
- g. Loss resulted from the fire.

It is apparent that the fire could have been prevented or the loss minimized by more effective action at each step. Study of the details of the fire scenarios will identify the areas where the most effective measures can be taken to minimize fire impact in similar situations in the future.

### **3.4 Fire Scenario Analysis**

#### **3.4.1 Guidelines for Analysis**

● Prevention and control are the prime purposes of any fire scenario analysis and a comprehensive analysis rests heavily on the accuracy, level of detail, and completeness of the scenario. However, developing this kind of fire scenario requires either (a) a completely documented report of a detailed post-accident investigation and analysis specifically aimed at determining how and where the fire started and progressed until extinguishment; or (b) a similar report of an instrumented full-scale test burn, or (c) a combination of both. In any case, until existing knowledge of the dynamics of actual fires is augmented by additional fire dynamics research, development of fire scenarios will be an art rather than a scientific discipline. Nevertheless, the application of fire scenario analysis appears to be a most productive methodology to identify economical, effective means to improve fire safety in our increasingly complex environment.

The analysis of any fire scenario might be accomplished in various ways; however, one effective means would be to ask a series of questions concerning each essential fire scenario element. The answers to these questions should suggest means for prevention and control, while providing a basis for materials selection, design criteria, validation of test methods, promulgation of codes and standards, and research and development objectives. Typical questions that one might ask are shown below.

##### **3.4.1.1 Prefire Situation**

1. Were existing codes adhered to? If so, did they yield adequate performance? If not, why not, and would they have been effective had they been enforced?
2. Were materials installed properly? If so, did the materials contribute to fire growth or did they help contain it? Would other installation procedures have been better?

##### **3.4.1.2 Ignition Source**

2. In as much detail as possible, what was the ignition source?
2. For how long was it in contact with the ignited material prior to flaming ignition? If this is not known, could it be determined by a separate experiment?
3. Could the ignition source be eliminated? How? By education? By design?

##### **3.4.1.3 Ignited Material**

1. What was the originally ignited material? If composite, what were the various layers?
2. What was the application of the material (e.g. drape, rug, cushion)?
3. How was it located relative to ceiling and nearest wall? To other materials?

## BUILDINGS

4. What were ventilation conditions in the room?
5. What was the relative humidity during the 48-hour period before the fire?
6. Did melting and dripping of the ignited material occur? Did this significantly affect the fire spread?
7. Did the ignited material collapse, fall over, etc.? If so, what effect did this have on the fire scenario?
8. Once the ignited object is fully involved, is it possible to state its heat release rate quantitatively?
9. Are there other materials that could have been employed in this application which would not have ignited under the same exposure conditions? If so, why weren't they employed?
10. Do flammability tests on materials intended for this application adequately measure ignition resistance to this level of ignition source? Should they?

### 3.4.1.4 Flaming or Smoldering Combustion

1. Is it known whether smoldering preceded flaming? For how long?
2. If unknown, was the ignited material capable of smoldering?
3. Can the volume (and composition) of gases produced by smoldering be estimated?
4. Can the time-dependent concentration of smoke and toxic gases arriving at a strategic location some distance from the fire be estimated?

### 3.4.1.5 Fire Spread

1. How long did it take for the first ignited object to become fully involved?
2. If flame spread to a second object, what was the mechanism of energy transfer?
3. How was flame spread influenced by sudden events, such as breaking of windows, opening of doors, curtains melting and dripping, spattering of burning droplets, etc.?
4. Did one or two materials significantly control the fire spread rate? Could the substitution of different materials, or the incorporation of design modifications alter the rate of fire spread and growth?

### 3.4.1.6 Smoke and Toxic Gases

#### Automatic Detection

1. If a smoke detector was present, how was it located relative to the fire? Did it respond as would be expected?
2. Supposing no smoke detector was present, how much sooner would the fire have been detected if a smoke detector had been present in a logical location? Would this have been soon enough to make a crucial difference?

### **Visibility**

Was visibility in an escape route obscured? When did this obscuration occur relative to detection time? Which materials seemed to contribute significantly to visibility obscuration?

### **Toxic Effects**

1. Were victims affected by toxic substances?
2. From the autopsy report what toxic substances caused death?
3. Did toxic substances interfere with victim's escape by promoting confusion?
4. Could these toxic substances be attributed to any one material?
5. Did victim(s) have pre-existing conditions such as limited mobility, circulatory disease, recent alcohol or drug intake, etc.?

#### **3.4.1.7 Extinguishment**

1. How large was the fire when first detected? What were visibility conditions at this time?
2. How much time elapsed between detection and attempted extinguishment?
3. How large was the fire when extinguishment was attempted?
4. What was the extinguishment technique and how successful was it?
5. If automatic sprinklers had been present, how much sooner would they have been expected to control the fire, and how much less might the loss have been?

#### **3.4.1.8 Flashover**

1. Did flashover occur? How long after ignition? How long after detection?
2. Can crucial elements in the fire growth and spread process be identified in relation to flashover?

#### **3.4.1.9 Postflashover**

1. Did fire spread beyond initial compartment? How? Was door open?
2. How was ventilation system involved in fire spread?
3. Did walls, fire doors, etc., fail? If so, after how long?
4. Did fire spread to floor above? By what mechanism?
5. Did structural collapse occur? Was this due to code violations?

#### **3.4.1.10 Spread to Other Structures**

1. Did other structures ignite? How far away were they? What material first ignited?
2. Was radiation responsible? Were firebrands involved? Was there direct flame contact?
3. What were the wind conditions?

4. Did firefighters attempt to protect exposed structures? How soon before spread occurred?

#### **3.4.1.11 Summary**

The availability of accurate, detailed, complete fire scenarios allows opportunity for an in-depth fire hazard analysis as illustrated by the questions shown above. As these questions are raised, and some answered, improved means for fire prevention and control will emerge. These may involve more education, better material selection, improved designs, installation of detection equipment, more stringent codes, etc. However, whatever improvement emerges, it will be based on a comprehensive overall system analysis of the problem. This is the fire scenario analysis approach to the fire problem.

#### **3.4.2 Analysis of Selected Scenarios**

This section is primarily intended to illustrate the fire scenario approach to improve fire safety. To this end, three generalized fire scenarios will be developed; one will deal with a single-family residential fire, another with a nursing home fire and the third with a nuclear power plant fire. Reference to an apartment fire is also included. These scenarios are selected to show the application of the fire scenario approach to a diversity of building fires. The scenarios will include essential fire elements as presented in Section 3.3.1; the scenarios will be prepared and analyzed in such a manner as to permit generalization from the particular incident described.

The major reason for the development of fire scenarios is to identify means to help prevent or control similar fires in the future. Thus, these scenarios will be analyzed to pin-point hazards, suggest opportunities for fire prevention, and direct attention towards methods for control.

The specific goal of this section is to demonstrate that fire scenario development and analysis is a productive methodology for improving the selection and use of polymeric materials to increase fire safety in buildings.

##### **3.4.2.1 Single-Family Home**

###### **Description**

An early morning fire, which started in the living room of a seven-room, two-and-one-half-story, wood-frame house, claimed the lives of a mother and her three children. This was despite the installation of single-station heat-activated fire detection devices in the home less than 18 months earlier.

On the night of the fire the mother and the 6-year old daughter were in the living room. The girl, who was sick with a virus, had been coughing and vomiting. The mother planned to stay downstairs with the girl through the night so as not to disturb the rest of the family. Around 10 P.M. the father went to bed and closed the door to the stairway between the first and second floors. At that time the mother was awake in the living room watching television. The girl was asleep on the sofa.

The mother fell asleep sometime thereafter and a fire started when her glowing cigarette ignited the upholstered chair she was sleeping in. The fire then spread to other furnishings in the living room. Walls were wood paneling over the original plaster and wood lath walls. The furnishings comprised nylon pile carpeting over a separate rubber pad, three upholstered chairs, and an upholstered sofa.

Shortly after midnight a 15-year-old daughter sleeping on the second floor awoke to smell smoke and realized that there must be a fire in the house. She carefully opened her closed bedroom door intending to waken her three younger brothers in adjoining bedrooms. However she bumped into her 8-year-old brother in the hallway. The smoke was very heavy so she grabbed his arm and led him back into her bedroom, closing the door behind her. Crawling low in accordance with her fire emergency instructions, they reached and opened the bedroom window and screamed for help.

Their screams roused neighbors who telephoned in the alarm. At about this time the heat-activated fire device in the living room sounded an alarm, awakening the father who was able to escape out his bedroom window. The 15-year-old girl and her brother were rescued by neighbors from their bedroom window. The living room flashed-over before the fire engines arrived. Firefighters wearing self contained breathing apparatus entered the building from the rear and attempted to rescue any children trapped on the second floor. They found one four-year-old boy in the hallway and another three-year-old on the floor of a bedroom next to a bed. Neither of these two children could be revived. The mother and six-year-old girl in the living room also perished. The girl's body was discovered six feet from the front door, the mother's body was found a few feet from the upholstered chair. The fire was confined mainly to the living room and the adjacent kitchen area.

### **Analysis**

It is estimated that 6,600 persons lose their lives each year in residential fires in the United States, and approximately two-thirds of these deaths result from fires in one- and two-family dwellings. Most of these fatal fires start at night and most of the victims die from inhaling smoke and toxic gases. Many never awake from sleep. Many might have been saved if they could have been awakened during the early stages of the fire. Analysis of the above fire scenario will yield information on means to provide time to escape.

### **Ignition Source and Ignited Material**

The above scenario, a residential furnishings fire caused by smoking materials, has been shown to be the most common fire death scenario (NBS, Jan. 1976), accounting for 27 percent of all U.S. fire deaths. Thus this is an excellent starting place in attacking the residential fire problem.

Those items of a residence normally controlled by building codes, such as structural components and interior finish, are seldom the first items ignited in fatal fires.

## BUILDINGS

The item first ignited in most fatal fires is a furnishing. Hence the building contents, not the building itself, is the most likely starting point for a fatal fire. Breaking the fire chain by preventing first material ignition is best done by improving the resistance of furnishings, particularly upholstered furniture coverings, mattresses and other bedding, to low energy ignition sources, e.g. cigarettes and matches.

### **Smoldering Combustion**

The upholstered chair, after ignition, apparently smoldered for a while before bursting into flames. This phenomenon is probable with most of the recent upholstered furniture (A sofa cushion made of polyurethane and foam rubber under a synthetic fabric cover can burn entirely in the smoldering mode).

The fact that smoldering occurred is important in that: 1) the smoke and gases produced during this stage could have permitted early detection of the fire had a single-station smoke detector been provided, 2) the pyrolysis products were probably toxic, and 3) the transition to flaming produced a rapidly growing flaming fire due to the preheating of fuel and accumulation of combustible gases which had occurred during the smoldering period.

The heat-activated single-station fire detection and alarm units were not effective in detecting the fire until it had grown to a fatal size. The system was able to alert the father, but too late for him to save any other members of the family. Had smoke detectors been installed, the outcome would probably have been different. In many instances of residential fires reported to NFPA, early warning smoke detectors gave families enough time to escape from their burning home before being overcome by smoke or fumes. One estimate, in fact, is that as many as 3,400 lives could be saved annually if every dwelling unit were provided with two single-station smoke detectors. (McGuire and Ruscoe 1962).

### **Fire Spread**

There does not seem to be any one item which was responsible for fire spread. The living room and its contents received heavy damage. The wood paneling was heavily charred or consumed as was most of the furniture. There was some charring and heat damage to the ceilings and walls in the kitchen. The fire had broken out the living-room window and charred the exterior wood siding. The remaining damage throughout the house was primarily smoke.

### **Smoke and Toxic Gases**

Two children perished on the second floor, the mother and 6-year-old girl died in the room of fire origin, the living room. The medical examiner's reports indicated that all the victims showed carboxyhemoglobin saturation levels sufficient to cause death. Both bodies in the living room were burned beyond recognition.

The girl apparently moved from the sofa but was overcome before she could

reach the exterior door from the living room. The positions of the boys' bodies on the second floor indicated that they attempted to move from their beds but succumbed to smoke and toxic products of combustion from the fire in the living room.

Fire prevention education that the 15-year-old girl had received in school and procedures practiced at home with the family were significant factors in the saving of two children. During the fire she remembered to keep low below the heat and smoke, to check the door of her room for heat before opening it into the corridor and to close the door upon returning to her room with her brother. Also she did not panic while waiting at the window for rescue.

### Summary

Analysis of the above fire scenario has suggested the following means for preventing a similar occurrence in the future.

1. Attention should be paid to developing materials for use in home furnishings which are resistant to ignition from smoking materials.
2. Early warning smoke detectors can significantly reduce deaths from slowly developing night-time fires. Heat-detectors are not effective in dealing with this hazard.
3. Fire prevention programs conducted in the local schools, augmented with prefire planning at home, can be extremely effective when dealing with a fire emergency.

### 3.4.2.2 Apartment Fire

The development and analysis of an apartment fire scenario is contained in Chapter 7 of Volume 4 to which the reader is referred.

### 3.4.2.3 Nursing Home Fire

#### Description

After a 72-year-old patient in a ground floor room had finished his evening meal and was sitting on the edge of his bed smoking his pipe while watching television, he apparently dropped a lighted match into a nearby plastic waste basket. The ensuing fire ignited the bedspread and the leg of his trousers. Apparently somewhat confused, the man moved from his bed to an adjacent bed.

The fire burned for a short time before actuating the automatic fire alarm, releasing certain corridor smokestop doors held open by electromagnetic door holders. Simultaneously the building internal evacuation alarm sounded. The Fire Department was summoned by telephone from the nurses' station.

Smoke and heat from the fire rapidly built up and traveled into the hallway. The fire completely destroyed the room interior. The paint on the hallway walls blistered and the nylon carpeting melted, as the fire spread down the hallway.

When the firemen arrived they quickly extinguished the fire. Seven of the 43



patients were pronounced dead immediately. Smoke inhalation was listed as the cause of most of deaths. Four others died later. Six of the eleven that perished were in ground floor rooms with the doors open; four others were in rooms on the second floor. The patient who started the fire died from severe burns. Patients two rooms from the room of fire origin survived; the door to their room was closed.

### **Analysis**

A detailed analysis of this and other nursing room fire scenarios suggests numerous means and opportunities for prevention and control.

### **Pre-Fire Situation**

The home was a modern two-story fire-resistive building. It had sprinklers in certain locations and also heat-sensitive fire protection devices. Smokestop partitions with doors held open by electromagnetic door holders were located at the left and right of the central lobby on each floor. The three stairways were enclosed, as was the elevator. It seemed as though a great deal of attention had been given to fire safety: fire resistive construction, sprinklers, smokestop partitions, enclosed stairways. Yet eleven elderly residents lost their lives before they could be rescued — seven on the first floor, four on the second. A further analysis will yield the shortcomings of this specific fire safety approach.

### **Ignition Source and Ignited Material**

Ignition of the clothing, bedding and other room furnishings and contents of an elderly patient by careless use of smoking materials is a frequent occurrence; and it is usually fatal. The records show that the ignition sources are matches, pipe ashes, cigarettes, and lighters. In many cases the records state that the patient has had a history of carelessness in the use of smoking materials.

It is impossible to supervise closely 100 percent of the elderly 100 percent of the time. Often the elderly place their clothing over heaters to dry. There are many instances on record of bedclothes and garments ignited from contact with heaters and other heat sources.

Sometimes the patient aggravates the problem by unsuccessfully attempting to extinguish the fire rather than seeking help or sounding the alarm.

It is not uncommon for patients to set fires purposely, for various irrational reasons. In one case a 71-year-old patient used matches to burn off the restraining straps on her wheelchair and flames spread to her clothing. In another, a 77-year-old man who had been reprimanded for not cleaning up litter on the floor of his room threw a lighted match into the litter, then attempted to put out the fire with other litter on the floor and cups of water.

The reaction of the elderly to a fire incident is perhaps the most dangerous of the factors that make the elderly a fire problem. On discovering a fire a patient is likely to ignore it, to be transfixed by it, or to seek refuge from it in his room and

fail to notify anyone else of the fire. It is difficult to design protection under these circumstances.

What then are the answers? One answer is flame-retardant pajamas, bedding and other fabrics that surround the patient! Is it too much to ask that occupants of nursing homes who smoke or cannot be trusted with matches be so protected? Adequate fire detectors are another answer. While heat-sensitive fire detectors like the ones present in the building of this discussion are useful in detecting fires once they have grown to a certain stage, the delay in detection is too late to save the victim. In a situation like this a detector sensitive to the products of combustion (e.g. a smoke detector) located in the room might have alerted an attendant before the victim had suffered such severe burns. Finally, a sprinkler in the room, while probably unsafe to assist in the life safety of the individual whose clothing caught fire, would keep the fire from spreading from the room of origin. (Note: While this building had sprinklers, it had been decided that they were only needed in the rubbish and laundry chutes).

### **Fire Spread**

Laboratory tests done on the carpeting after the fire indicated that the nylon carpeting material used in the nursing home (which included an integral combustible black foam rubber backing) would not readily spread fire when exposed to a small ignition energy source such as a lighted cigarette; however, under intense heat exposure, such as provided by the room fire, it was capable of propagating flame. The rubber backing on the carpeting was the principle source of the smoke from the fire.

Hence care must be taken when selecting carpeting, or any other combustible materials (e.g. paneling, ceiling tile) for use in hallways. The materials chosen should exhibit a low flame spread rate under realistic fire conditions and smoke production must be limited.

### **Smoke and Toxic Gases**

Smoke and toxic gases were the primary cause of the fatalities. Smoke and toxic gas production on the first floor could have been controlled by a better choice of materials or more rapid detection and extinguishment. These have been mentioned above. However the major reason that smoke entered the second floor was faulty design.

Once the fire in the room burned through the suspended ceiling, smoke and heat traveled to the rest of the building through the concealed space above, upward through openings around utilities to the second floor, and, to a lesser extent, through the building ventilating system. Smoke and soot were deposited where utilities entered rooms and pierced floors.

There were no utility shafts (continuous fire-rated enclosures) commonly required by building codes. The utility piping and conduit pierced the floor in many

## BUILDINGS

areas of the building and were enclosed from the floor slab to the suspended ceiling above by plywood on metal and wood studs. Oversized floor openings around the pipes and conduit allowed the smoke to travel vertically with little resistance. The smoke spread horizontally because the concealed ceiling space over the first floor rooms, corridors and lobby was continuous and extended over smokestop doors.

Thus, once the fire had entered the ceiling space above the first floor there was nothing to stop smoke spread throughout the building. This uncontrolled smoke spread was directly responsible for the four deaths on the second floor, and certainly contributed to the six smoke inhalation deaths on the first floor.

### **Extinguishment**

The Fire Department extinguished the fire in a short time, using less than 1500 gallons of water. However, while the actual fire damage was light (approximately \$175,000) eleven persons lost their lives. Had an automatic sprinkler been present in the room, there is little doubt that it could have confined the fire to the room and prevented ten smoke inhalation deaths. Had a smoke detector been present, possibly an attendant could have responded quickly enough to have saved the patient in the room as well.

### **Summary**

There are a number of lessons, not necessarily new, that are emphasized by analysis of the foregoing scenario. The elderly present a special, unique fire problem. They are responsible for a significant number of fires because of the physical and mental conditions that accompany old age. In addition, the discovery of fire does not necessarily suggest to them the need to alert other occupants of the building or to save themselves. In a fire, the elderly are not only more helpless than the average person trapped by fire; they are often transfixed by the emergency, even refusing to leave their quarters and resisting efforts to remove them from the building. Having been taken out of the building, the elderly are likely to return to the burning structure.

The above analysis suggested the following means to render an existing nursing home more fire-safe.

1. Reduce the amount of combustibles. This applies to finishes, furnishings, and draperies as well as rubbish and trash. There are numerous combustible items that are necessary for the efficient operation of a nursing home (or hospital), e.g. bed linens, patient clothing, towels, mattresses, curtains, disposable paper products. The more of these items that can be discarded or replaced in favor of more fire-safe materials, and the more remaining items that can be made fire retardant, the safer will both patients and nursing home personnel be against fire peril.
2. Select interior wall and ceiling finish materials to have low flame spread and smoke generation ratings .
3. Design and install effective barriers to limit the spread of fire and smoke –

not only into stairway enclosures, but also into concealed spaces above hung ceilings, elevator shafts, utility shafts, etc.

4. Install sufficient smoke detectors (products of combustion detectors) to alert attendants (and the fire department) to the presence of a fire in its early growth stage. This could allow effective action to be taken to save those immediately exposed.
5. Install automatic sprinkler protection to extinguish the fire, or at least confine it to its original location until additional help arrives.

### 3.4.2.4 Nuclear Power Plant Fire

#### Description

A 26-inch-thick reinforced concrete barrier separated the Cable Spreading Room (CSR) from the Reactor Building (RB). Cable trays carrying control and instrumentation wiring from the CSR to the RB butted up to either side of the wall. Cables were placed in sleeves which passed through a steel plate in the wall. To provide an air and fire seal in the sleeves, a polyurethane foam material was stuffed in around the cables. Foamed-in-place polyurethane was used to fill the sleeves; this was followed by application of a fire-retardant silicone rubber to cover the foam and provide a fire seal. The reaction building was maintained at a negative pressure to insure that air flow was inward.

At the time of ignition, polyurethane foam sheeting had been stuffed in around the cables from the CSR side of the wall. An employee used a candle to check for air leaks through the fire wall penetration seal (the candle would flicker if flow was present). Due to the differential pressure across the wall, the candle flame was drawn into the hole towards the reactor building igniting the polyurethane foam. The presence of the differential pressure-induced draft aggravated the flames and the fire was drawn rapidly towards the reactor building. The actual seal was set back into the wall several inches and was a difficult area to reach because of the congested cable trays. Immediate attempts to extinguish the flames by beating them out with a flashlight and smothering them with rags failed.

The cables were predominately polyvinylchloride (PVC) control cables. The PVC started to burn and during approximately seven ensuing hours, about 1700 cables and 27 trays burned for distances up to forty feet. The fire proceeded in several directions after entering the reactor building and was transmitted to other cable trays on all sides of the original tray.

Shortly after the start of the fire, the CO<sub>2</sub> fire suppression system was actuated manually. It appeared to control the fire in the CSR, but had to be reactivated twice more during the incident. Eventually, the fire on the CSR side of the wall was terminated by the use of hand held CO<sub>2</sub> and dry chemical extinguishers.

While the fire was being fought in the CSR, the fire progressed into the reactor building. Within ten minutes after the fire started, firefighting efforts commenced in the reactor building. The burning PVC emitted dense clouds of acrid black

smoke. Burned-out power cables caused a loss of ventilation in the reactor building. The smoke densified and firefighters (already in breathing apparatus) found it more and more difficult to reach and fight the fire. The air packs did not give the fighters time sufficient to find their way to the fire and fight the fire for longer than a few minutes.

Eventually, firefighting efforts were terminated for two hours while partial ventilation was restored to clear some of the smoke. Ultimately, the fire was put out by the use of water hoses. Loss was estimated at more than seventy million dollars.

### **Analysis**

Analysis of the events surrounding this fire teaches lessons that can be utilized to prevent similar incidents at other nuclear plants or other installations employing significant amounts of cables in relatively inaccessible places (e.g., telephone exchanges).

### **Ignition Source and Ignited Material**

While it may have been difficult to anticipate ignition from a candle flame, if this is the standard or a frequent procedure for checking for air leaks, this fact should be known to those responsible for sealant material selection. Care must be taken to select less combustible, or if possible, non-combustible, sealant materials (e.g., inorganic fiberboard, silicone foam). Any material which would ignite under this relatively low level ignition source should be removed and replaced.

### **Flame Spread**

The wide-spread use of combustible nonmetallic cable constructions in nuclear power stations, telephone exchanges, etc., has introduced a fire hazard with enormous dangers. Unless the seriousness of this hazard and its consequences is immediately recognized, additional losses involving many millions of dollars can be expected.

It has been frequently said that grouped nonmetallic cables will not burn or propagate a flame. Unfortunately, users of electrical cable are often led to believe that their tray cable is "nonburning," "non-propagating," "fire resistant" or "self-extinguishing." Recent cable fires and cable tray tests indicate that this is not so.

Cable construction frequently sacrifices flame resistance for improved resistance to moisture, corrosion, oil, radiation and ozone. The result is a cable construction that will burn in almost every conceivable tray configuration. The corrosivity and toxicity of burning cable are often ignored when selecting a cable construction. Whenever PVC, Neoprene, or Hypalon cables are burned, hydrogen chloride (HCl) gas is evolved. Combined with ambient water vapor, the hydrochloric acid will attack building steel, electrical equipment and instrumentation, resulting in a major corrosion loss.

All of the cables under discussion consisted of a polyethylene (PE) or cross-

linked polyethylene insulation and a PVC, Hypalon or nylon overall jacket. A review of the flame-retardant requirements of the cable indicated that: (1) all single and multi-conductor cables No. 8 and larger were required to pass UL Standard No. 83 (vertical flame test); (2) all cables No. 9 and smaller were required to pass the IPCEA horizontal test; (3) single and multi-conductor cables having a nylon jacket were not required to pass *any* test.

Small-scale tests can be very misleading, especially for grouped multi-conductor control and power cables. Users should have insisted on stringent cable fire tests indicative of "real-life" fire exposures. One such test currently being used by some utilities is the IEEE No. 383 flame test. Another option is to insist that fully loaded, tiered trays, be tested, using more severe ignition sources and fire exposures.

Minimal consideration seems to have been given to the burning characteristics of the cables. Had there been concern, it would have been evidenced by more stringent flame tests and better grade fire retardant cable constructions.

### **Smoke and Toxic Gases**

Prompt effective removal of heavy concentrations of smoke and toxic gases is essential when combating a fire. Such removal of heat and smoke enables fire-fighting personnel to gain early access into the fire area to extinguish the fire or to shut down the station and perform emergency rescue work. Also it reduces smoke and acid vapor damage.

Smoke and acid fumes generated by the burning cable were so intense that firefighters were required to wear self-contained breathing apparatus. Fortunately, such equipment was on hand; unfortunately, it did not provide adequate on-site breathing time. Had the ventilation system of the Reactor Building continued to operate unimpaired the fire probably would not have burned for seven hours. Instead, within fifteen minutes of the start of the fire, the ventilation system ceased operating. Apparently, its power supply was located in one of the cable trays involved in the fire.

Running temporary wires to bypass the damaged cables, the ventilation system was turned back on four hours later; it helped to clear the area of smoke and noxious gases and allowed firemen to evaluate their next move.

### **Extinguishment**

Ultimately, as mentioned previously, the fire was put out by the use of water hoses. Prior to that, fifty-one portable fire extinguishers were discharged into the fire, as well as two large cart type extinguishers. One important lesson was that CO<sub>2</sub> and dry chemicals are largely ineffective in fighting large cable fires, since neither cools the cables, Residual heat will repeatedly reflash the fire after the flames are knocked down.

Since plastic electrical fires are Class A materials when they burn, extinguishing agents compatible with Class A fires should be used, e.g., water, light water, multi-

purpose dry powders, etc. Extinguishing agents including carbon dioxide, halon, B:C dry powders and foams that do not have a cooling effect are normally ineffective and should not be used.

Of the systems currently available, automatic sprinkler protection seems to be the recommended choice. It offers the most effective and efficient way of putting out a burning cable fire. By wetting-down and cooling the red hot conductors, the Class A fire can be readily extinguished without much concern over reflash.

### Summary

Analysis of this nuclear power plant fire results in the following suggestions for improved fire safety.

1. The original sealant materials installed in cable penetrations should be replaced with new sealant materials of limited combustibility.
2. A re-evaluation of current cable flammability testing requirements should be made to establish pass-fail criteria for flame propagation in cable tray systems under "real-life" fire conditions. Consideration should be given to employing IEEE No. 383 flame test as a minimum requirement.
3. Existing cable trays could be made more resistant to fire by application of a flame-retardant cable coating to exposed cable surfaces in areas of high cable density, and installation of effective firestops in cable trays.
4. Cables whose insulation does not liberate copious quantities of corrosive gases should be employed whenever practical.
5. Isolation of floors in all buildings should be considered in view of the smoke problems that inhibited firefighting efforts so severely.
6. Approved smoke and heat venting facilities independent of the station's normal ventilation system should be provided throughout areas having a combustible occupancy. Each system should be powered from electrical feeders run outside the fire area and be actuated by products of combustion detector servo systems.
7. Careful evaluation of current self-contained breathing apparatus needs to be performed. The present half-hour time limit was not adequate either for firefighting or local equipment manipulation.
8. Cable tray systems should be protected by automatic water spray sprinkler systems actuated by a fast acting product of combustion type detection servo system.

## 3.5 Conclusions and Recommendations

### 3.5.1 Conclusions

1. Although no two building fires are exactly the same, the development and analysis of fire scenarios assists in the identification of common elements in fires. This allows identification of the critical stages in fire development and suggests opportunities for fire prevention or control.



2. Scenarios should be prepared in such a manner as to permit generalization from that particular incident described.

3. Detailed scenarios should include consideration of the probable effect on fire behavior of various alternative conditions (building design, materials involved, mode of fire initiation, intervention strategies) as contrasted to the actual or initially assumed set of conditions.

4. At present, insufficient use is being made of the fire scenario technique to advance fire safety, particularly as new materials are introduced into building construction.

### 3.5.2 Recommendations

1. Develop a wide spectrum of generalized building fire scenarios, as outlined in this chapter, based on real or credible incidents, by those knowledgeable in fire dynamics and fire safety.

2. Further quantify when necessary the specific fire dynamic elements in these scenarios, e.g., rate of fire spread, rate of heat release, etc., by information obtained from full-scale experiments. The ultimate goal is to develop the capability of employing analytical models to predict fire hazard and thus replace expensive full-scale experiments.

3. Use scenarios for the analysis of fire hazard and for the development of methods to provide increased safety. In particular, these scenarios should contribute to materials selection, design criteria, validation of test methods, promulgation of codes and standards, and research and development objectives.

4. Base the design and construction of any building, among other things, on the development and testing of the design against appropriate fire scenarios.

5. Train fire protection specialists and building designers in the development and use of fire scenarios, so as to enable them to identify critical fire hazard elements and appropriate protective measures.

### References

- Berl, W. G., Fristrom, R. M., Halpin, B. M., "Fire Problems," *APL Technical Digest*, Vol. 14, No. 2, April-June 1975, p. 9.
- Clarke, F. B. III and Ottoson, J., "Fire Death Scenarios and Fire Safety Planning," *Fire Journal*, Vol. 70, No. 3, (May 1976).
- Corman, H., Ignall, E. J., Rider, K. L. and Stevenson, A., *Fire Technology*, Aug. 1976, p. 200.
- Fire Journal, "Fires and Fire Losses Classified, 1975," *Fire Journal*, Vol. 70, No. 6 (Nov. 1976), p. 19.
- Harlow, David W., "International Fire Losses, 1974," *Fire Journal*, Vol. 69, No. 6 (Nov. 1975), p. 43.
- McGraw-Hill Information Systems Co., From F. W. Dodge Div., McGraw-Hill Information Systems Co., New York, N.Y. (1975).
- McGuire, J. H. and Ruscoe, B. E., "The Value of A Fire Detector in the Home," *Fire Study* No. 9, Ottawa: National Research Council of Canada, Division of Building Research, December 1962.
- National Bureau of Standards, "Reducing the Nation's Fire Losses, the Research Plan," Center



## BUILDINGS

- for Fire Research, National Bureau of Standards, January, 1976.
- National Fire Protection Association, A Study of One- and Two-Family Dwelling Fires, NFPA No. FR75-1, National Protection Association, Boston, Mass. (1975) (a).
- National Fire Protection Association, A Study of Mobile Home Fires, NFPA No. FR75-2, National Fire Protection Association, Boston, Mass (1975) (b).
- National Fire Protection Association, Nursing Home Fires and Their Cures, NFPA No. SPP-17, National Fire Protection Association, Boston, Mass. 1972.
- National Fire Protection Association, *Fire Protection Handbook – Fourteenth Edition*, G. P. McKinnon, editor, National Fire Protection Association, Boston, Mass., Jan. 1976.
- National Fire Protection Association, "Multiple-Death Fires – 1975," NFPA Analysis Department, *Fire Journal*, Vol. 70, No. 4, (July 1976), pp. 27–28.
- National Fire Protection Association, "A Study of Fatal Residential Fires,; *NFPA FR-72-1*, National Fire Protection Association (1972).
- National Fire Prevention and Control Administration (Department of Commerce), Highlights of the National Household Fire Survey, U.S. Department of Commerce, National Prevention and Control Administration (1976).
- National Fire Protection Association, *Facts About Fire*, National Fire Protection Association, Boston, Mass., 1976.
- Zentner, R., "Scenarios in Forecasting," *Chemical and Engineering News*, Vol. 53, No. 40 (October 6, 1975), p. 22 and references cited therein.

## CHAPTER 4

### MATERIALS

#### 4.1 Introduction

This chapter is organized into four major sections that look at the fire safety aspects of polymeric materials in buildings from various aspects. In the first section — *Materials Used* — the emphasis is on the various polymers, where and how extensively they are used, and their relationships to fire safety in buildings. The second section — *Building Structure* — covers the various types of construction, the building elements and utilities and services involved, and where and what polymeric materials are used. The third section — *Residential Occupancies* — considers the types of structures used for residence, the contents associated therewith and the contribution of polymeric materials to the fire safety aspects thereof. Considerable emphasis is devoted to residential occupancies since statistics show that the overwhelming majority of building fire fatalities (about 90 percent) occur in residential buildings. The fourth section — *Other Occupancies* — covers the major other occupancies where polymer materials could play a significant role in personnel fire safety. Many of the material-related elements of residential uses are also common to these other occupancies.

#### 4.2 Materials

Materials are discussed under the same general headings used in Volume I, "State-of-the-Art-Materials:" Wood and Wood Products, Plastics, Fibers, Foams, Elastomers and Coatings.

*Wood and wood products* represent by far the largest volume of use in housing. In most uses such as framing, sheeting, flooring, furniture, cabinets, wood can be considered the "conventional" or "traditional" material and consciously or unconsciously one tends to compare other materials with wood in whatever characteristic is being considered (i.e., fire safety). Insulation in the form of fire-retarded shredded waste paper represents a relatively new and growing use of a cellulose material.

Use of *plastic materials* in the building structure and in furnishings is increasing rapidly. There is much concern and confusion as to what materials in what uses may constitute increased fire hazard and what alternatives and tradeoffs are available and desirable.

Increasing use of *fibers* (natural and synthetic) results from a trend to full carpeting of houses. The fire safety aspects of carpeting in residences has received considerable attention and federal standards have been promulgated to cover these products.

Use of *foam*, both flexible and rigid, is increasing for cushioning, insulation and

structural applications. Fire safety of foams is an intensely active area. Regulations have been issued for mattresses and for rigid foam insulation. Regulations are pending for upholstered furniture. Use of structural foam for furniture, trim, panels, cabinets, etc. is rapidly increasing accompanied by frequent change and extensive development. Fire safety of such products is a concern.

The use of *elastomers* (other than foam) in residential buildings (floor tile, sealants and other minor application) is small compared to the total usage.

*Coatings* are widely used both in interiors and exteriors for protection and decoration. They can have either a positive or negative impact on fire safety of a system.

Under each class of material, when applicable, are discussed the specific materials by type and modification, the rationale of use, future trends, and some general fire safety aspects in these uses.

#### 4.2.1 Wood and Wood Products

Wood in the form of lumber has long been a principal material for the construction of housing and furniture. Wood can also be sawed, sliced, chipped, or separated into fibers to be used in the fabrication of laminated wood, plywood, paper, particleboard, hardboard, or fiber insulation board panels. These products are having increased application in housing and furniture. General information on wood and the wood products, fire performance and safety considerations, and fire-retardant treatments and coatings is given in Volume 1, Chapters 2 and 7. The use of wood and wood-based products in buildings is discussed and extensively referenced in the NFPA, "Fire Protection Handbook" (McKinnon 1976).

Table 4.1 summarizes the annual use of lumber and wood-base panel products for residential construction. Some of the specific uses of lumber and wood-base products include the structural framing, floor, roof and wall sheathing, siding and exterior trim, roof shingles and shakes, flooring, cabinets, doors, and interior trim and paneling.

The use of wood and wood-base products in certain types of buildings has been limited because of combustibility. However, such products are extensively used in one- and two-family housing and in moderate-size multi-family residences of three stories or less. Much of the wood framing of the walls and ceiling has been protected with either plaster or gypsum wallboard. There has been regulation of the proper clearances for the wood materials from chimney and fireplace construction, distances from heating devices, and provision of firestops within walls to prevent spread of combustible gases or flames through wall spaces to upper floors or attic.

Wider usage of wood-base interior wall panels, trim, and cabinets presents additional opportunity for ignition and flame spread. The hazard of these lining materials must be considered in relation to the often greater hazard of the contents of rooms. However, codes are starting to limit the flammability of large areas of exposed interior lining materials in housing.

MATERIALS

Table 4.1. Wood Products Used in Residential Construction

Building Structure	One- and Two-Family Housing	Multifamily Housing	Mobile Homes
	Total Weight <sup>1</sup> in 1000 metric tons	Total Weight <sup>2</sup> in 1000 metric tons	Total Weight <sup>3</sup> in 1000 metric tons
Total -- All Uses			
1. Lumber	9,860	3,629	623
2. Plywood	2,200	931	266
3. Particleboard and Hardboard	995	63	278

<sup>1</sup> Computations based on the volume per unit (1968), "Wood Products Used in Single-Family Houses Inspected by FHA," U.S. Department of Agricultural Statistical Bulletin 452, GPO (1970), and the average number of units for 1970-74 as given in "Housing Starts," Bureau of Census, U.S. Department of Commerce.

<sup>2</sup> Computations based on the volume per unit (1969), "Wood Products Used in Apartment Construction," USDA Forest Service, Forest Economics and Marketing Research Paper WO-16, and the average number of units for 1970-74 as given in "Housing Starts," Bureau of Census, U.S. Department of Commerce.

<sup>3</sup> Computations based on the volume per unit (1970), "The Outlook for Timber in the United States," USDA Forest Service, Forest Resource Report 20, (1973), and the average number of units for 1970-74 as given in "Housing Starts," Bureau of Census, U.S. Department of Commerce.

Fire-retarding treatments and coatings are available for use with lumber and wood-base products as described in Volume 1, Chapter 2, Sections 3 and 4.3, and in Chapter 7. The chemical treatments reduce the hazard of initial ignition; decrease the rate of surface flame spread and the initial rate of heat release; cut back the total smoke development; and, render the material less subject to afterflaming and afterglow. These treatments increase the cost of the wood products by 50 to 100 percent, and have some effect on moisture absorption, appearance, strength, and machining, gluing, and finishing characteristics. Most of these treatments are limited to interior applications.

Therefore, while the chemical treatments do decrease the flammability of the wood materials, the costs and effect on properties have limited their use. This is particularly true for use in the one- and two-family residences where the value in the gain in fire safety may be questioned in relation to the uncontrolled presence of combustible contents.

The use of fire-retardant coatings for wood has generally been more limited than the chemical treatments because of limited code acceptance of "on-site" application, need for thick film applied in several coats, opaqueness of the more effective coatings, the need for special care in washing and high humidity exposures.

## BUILDINGS

### 4.2.2 Plastics

An overall picture of the use of plastics (wood, foams, fibers, elastomers and coatings are included in other sections) in construction and furnishings is given by the data in Tables 4.2(1), 4.2(2), and 4.2(3) (Modern Plastics, 1975). Over 95 percent of the total use of plastics is represented by six polymer types namely, polyvinyl chloride, styrene polymers, polyolefins, phenolformaldehyde, urea-formaldehyde, and glass-reinforced polyesters. The use of plastics by application areas is heavily dominated by pipe. Other major uses are electrical insulation (e.g., wire coatings), resin-bonded wood, appliances, and furniture. Such volume distributions, however, do not in themselves give indications of potential fire hazard. For example, much of the pipe is underground and much of the polyvinylchloride is in floor tile; neither of these presents a significant fire hazard in most building applications.

In the following discussions, more information on the types of products and their specific uses are given. More details on the chemistry, flammability characteristics, other properties and general applications for all these plastics are given in Volume 1, Materials-State of the Art, Chapter 5.

**Table 4.2(1) Use of Plastics in Buildings**

RESINS & PLASTIC APPLICATION	PVC	Polystyrene	Polyolefins	Phenol/Form	U-M/F	GRP	Acrylic	Nylon	Epoxy	Polycarbonate	Acetal	
Pipe, Fitting & Conduit	569	207	65			51			2		4	898
Wire & Cable Coatings	194		273					4				471
Resin Bonded Wood				167	301							468
Appliances	20	237	46			27	2	6	4	4	6	352
Furniture	145	75	21	37	7	15						300
Electric/Electronic		79		94	13	48		12	9	9	3	267
Flooring	211								5			216
Insulation				112								112
Panels & Siding	39	5				55	6					103
Vapor Barriers	29		70									99
Profile Extrusions	84		3									87
Lighting Fixtures	5	22					20			2		55
Wall Coverings	54	2										56
Decorative Laminates				26	24							50
Glazing		8					29			4		41
Plumbing & Bath Fixtures		2				27	5				4	39
<b>TOTAL</b>	<b>1350</b>	<b>667</b>	<b>478</b>	<b>436</b>	<b>345</b>	<b>221</b>	<b>88</b>	<b>22</b>	<b>20</b>	<b>19</b>	<b>17</b>	<b>3614</b>
(Numbers given are 1000's of metric tons)												

## MATERIALS

**Table 4.2(2).**

APPLICATIONS	%	100	200	300	400	500	600	700	800	900	1000	
Pipe, Fitting & Conduit	24.8											898
Wire & Cable Cuttings	13.0											471
Resin Bonded Wood	12.9											468
Appliances	9.7											352
Furniture	8.3											300
Electric/Electronic	7.4											267
Flooring	6.0											216
Insulation	3.1											112
Panels & Siding	2.9											103
Vapor Barriers	2.7											99
Profile Extrusions	2.4											87
Lighting Fixtures	1.5											55
Wall Coverings	1.5											56
Decorative Laminates	1.4											50
Glazing	1.1											41
Plumbing & Bath Fixtures	1.1											39
TOTAL												

(numbers given are 1000's of metric tons)

**Table 4.2(3).**

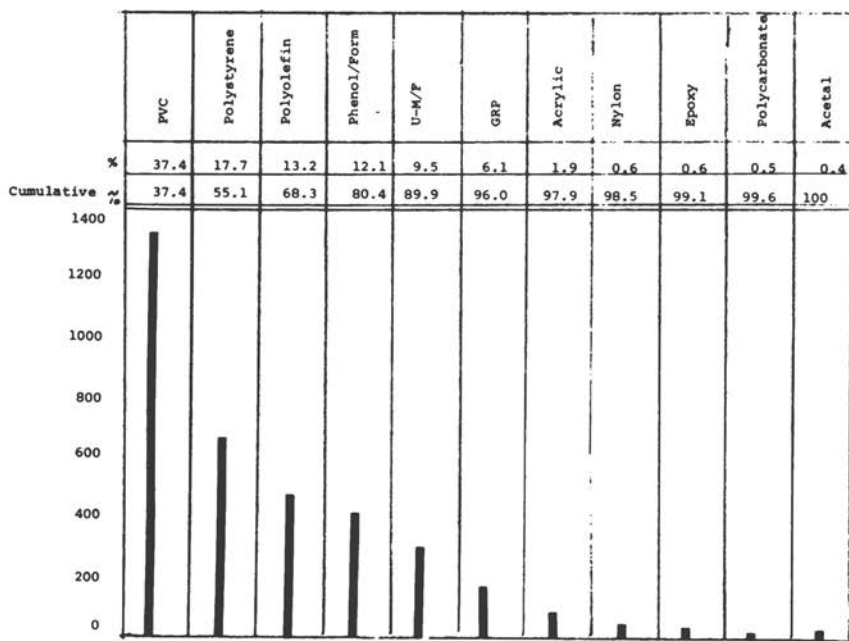

(numbers given are 1000's of metric tons)

#### 4.2.2.1 Polyvinyl Chloride

The flammability and fire retardant methods associated with polyvinyl chloride (PVC) and its formulations have been reviewed in Volume 1, State of the Art, Section 5.3.3. PVC is one of the least expensive of the commercial thermoplastic polymers; it has been sold commercially for more than thirty five years. PVC can be formulated into a wide variety of compositions. Properties vary from soft elastomers to tough rigid polymers. An extensive technology has been developed over the many years of commercial utilization. PVC is the least flammable of the low cost large volume thermoplastics because of its high chlorine content. Flammability of a commercial formulation can vary widely from a relatively low value (in the absence of an outside heat flux) to rapid burning depending upon the amount and nature of additives such as plasticizers, fillers, impact modifiers, reinforcements, etc. The combination of low cost, low flammability and great versatility makes PVC the largest volume polymer currently used in building and construction applications.

The major applications for PVC in building and construction are summarized in Table 4.2(1). By far the largest uses for PVC in these applications are in flooring, pipe, pipe fittings and conduit and wire cable coatings. More recent developments indicate an increasing importance of PVC structural foam profile-extrusions for residential construction. The low density (0.7 g/cc) of these cellular parts not only improves many desirable properties, such as rigidity and flexural strength as a function of unit weight, but also leads to a significant reduction in cost.

PVC is used extensively in mobile homes as floor coverings, wall coverings (much of which is laminated to plywood paneling), upholstery fabric, and decorative trim.

The fire hazard encountered in the proper use of PVC in pipe and pipe fittings applications is low, not only because of the location of the materials in these applications, but also because such formulations generally contain little if any flammable additives and exhibit a relatively high resistance to ignition and burning.

Although PVC wire coating and conduits are used in various applications in homes, no serious problems in fires have appeared. In industrial buildings, group cables containing PVC insulation have led to spreading of fire through walls and floors. These types of fires are reviewed in more detail in 4.3.3.1.

The fire hazard of PVC in flooring will vary depending upon the type and amounts of plasticizers, fillers, fire retardants and other modifying materials generally used in such formulations as well as the substrate on which the flooring is used. About 50 percent by weight of flammable plasticizer is often incorporated in such formulations (Sarvetnick 1969). Generally, the hazard is low due to the heat sink behavior of the substrate and the generally lower heat flux on a floor compared with walls and ceilings.

The flammability of extruded profiles and panels is generally low because of the low amounts of flammable diluents and plasticizers used in formulating. The flammability of higher density foamed extrusions would not be expected to increase significantly. Inorganic fillers are often used. This reduces the flammability of the final product even further.

## MATERIALS

Wall coverings, in contrast to the preceding usage, are generally highly plasticized, often with flammable plasticizer. They can present a fire hazard depending on the composition, the substrate and location of use. Flammability can be reduced by the use of fire retardant plasticizers.

### 4.2.2.2 Styrene Polymers

The general types of commercial styrene polymers and their flammability characteristics are reviewed in Volume 1, Section 5.3.2. Of these various polymers, copolymers, graft polymers and blends, the high impact polystyrenes (HIP) and the blend/graft copolymer of acrylonitrile/butadiene/styrene (ABS), are the most widely used in housing and major furnishings. Fire retarded versions of both of these materials are also used. Such fire-retarded compositions are generally made by adding halogenated additives (chlorinated aliphatics and alicyclics and decabromodiphenyl ether) with or without antimony oxide. Part or all of the halogen component may be incorporated in the form of halogenated polymers, such as PVC, in blends. The better fire retarded materials cost about twice that of the non-fire retarded materials and consequently their application is limited by cost considerations.

Most of the styrene polymers used in housing and furnishings are also used in formulations for pipe and appliances. The major styrene polymer in pipe, fittings and conduits is ABS. ABS pipe is widely used in drain waste and vent (DWV) applications in single family housing. The low weight, easy fitting, low corrosion and competitive costs are major advantages over metal pipe. The fire safety aspects of ABS pipe have been discussed widely and experimentally studied (Benjamin 1972). Obviously underground waste pipe presents no fire hazard. Drain and vent pipe in walls could lead to propagation of fires under some conditions. However, with proper construction (fire stops and due attention to wall composition) this hazard can be largely overcome (Parker, W. J., 1973). The use of fire-retarded ABS can further decrease the hazard of ignition and propagation but at a greatly increased cost using present technology.

The use of styrene polymers in appliances is mainly in refrigerator liners where ABS and HIP are used. The polymers used have not been fire retarded, due to the low probability of ignition or propagation of fire in this application. Other appliance uses include television cabinets, housing and grills for air-conditioners, dehumidifiers, etc. For these uses, fire safety is important and flammability requirements (e.g., TV cabinets) became more stringent in 1975 and may be increased further. Fire retarded versions of styrene polymers are required to meet the more stringent requirements.

Some dense styrene polymers (in addition to structural foam — see Section 4.2.3.2) are used in molded furniture and furniture trim. The volume is considerably less than for pipe and refrigerator liners but the potential for ignition and propagation is larger.



Some styrene polymers have been used in lighting fixtures but this use is decreasing in favor of methacrylate polymers.

#### 4.2.2.3 Polyolefins

Polyolefins, principally low density polyethylene (P.E.), high density polyethylene and polypropylene (P.P.) comprise a U.S. market in excess of ten billion pounds per year; but, less than 0.1% of this is used in building and construction.

The polyolefins can be formulated to provide a range of properties. This includes variations in processing parameters, heat resistance, rigidity, light stability, printability, friction, static properties, foam stability, strength, toughness as well as flammability (see Vol. 1, Sec. 5.3.1).

Electric cable coatings are made from all density grades of polyethylene (P.E.), sometimes crosslinked and sometimes partially foamed for modified dielectric properties.

Cold water pipe, cisterns, tanks and waste pipe are common applications for medium and high density P.E. and P.P. Polypropylene is also often used in drainage fittings.

Appliance design uses polypropylene for large structural and load bearing components; radio cabinets, dishwasher tub and door liners are representative products. Polypropylene is also used for structural components and as the upholstery covering in furniture. Carpet face fibers of polypropylene as well as non-woven polypropylene carpet backing are used in large quantities.

Corrugated PP board is now being used for durable and attractive shipping containers and applications in construction are apparent.

Structural foam extrusions of polypropylene find application in door and window frame trim, baseboards and covers, carpet tack strips and frame moldings.

Chemically, polyolefins are very similar to paraffin wax and they burn in somewhat the same way. They ignite easily, burn with a smoky flame, and melt as they burn. Polyolefins produce less smoke than polystyrene. The degree of melting and dripping can be enhanced or decreased by choice of molecular weight, crosslinking, fillers, additives, etc. The mechanism of burning, products of combustion, and flame retarding formulations have been covered in Volume 1 – State of the Art – Materials, Section 5.3.1.

Flame-retarded formulations are generally produced by blending polyolefins with halogenated aliphatic hydrocarbons in combination with antimony oxide. These formulations have greater resistance to ignition in low thermal energy flux environments. Flame spread rates can also be reduced. All known fire retarded polyolefin compositions burn readily in a fully developed fire.

The greatest fire hazards from polyolefin in buildings probably occur in grouped insulated wire and cables and in some proposed uses of structural foams. Specific hazards have to be evaluated on the basis of the exact use, environment, amount of material, other materials, etc.

## MATERIALS

Polyolefins are being used in large and increasing amounts in building construction and contents; thus, the possible hazard of excessive fuel load is introduced (see also Section 4.2.3.7). In some applications, they are being used in relatively high fire risk situations; for example, a portable gasoline camp stove with a polyolefin structural body has been advertised.

### 4.2.2.4 Phenol-Formaldehyde

Phenol-formaldehyde polymers are thermosetting resins and are practically always used in conjunction with fillers or fibrous reinforcements. The modified polymers are char-forming and do not readily support combustion in the absence of external energy input. (See Vol. 1, Section 5.4.1.)

In buildings and furnishings, the major use of phenolic resins is in resin-bonded wood. This includes plywood for sheathing, flooring, panels, cabinets, furniture and decorative laminates. Generally, such composites are less flammable than corresponding systems based on wood alone. These composites are discussed in Section 4.2.1 (Wood and Wood Products).

The second largest application of phenolic resins in buildings is as a binder in fiberglass insulation. About 10 percent resin (based on the glass) is used to bond the glass fibers to give dimensional stability to the insulating material. In this configuration, with the resin spread over a large surface area on an inert substrate, the resin can burn more readily than in a solid dense form such as a laminate. The system does not readily propagate a flame, but can propagate fire by "punking" or glowing combustion. This "punking" can be overcome by use of various nitrogen-containing reactants (melamine, dicyandiamide, etc.) in the phenolic resin. These compositions are used for special applications but are not generally employed for insulation in residential housing.

Molded phenolic resins have been used extensively in various electrical applications because of their combination of desirable electrical, mechanical and fire resistance properties. In some applications, phenolics are being replaced by special thermoplastics that have lower fabrication cost.

### 4.2.2.5 Urea-Formaldehyde, Melamine-Formaldehyde

The basic chemistry, properties and applications of these amino resins are summarized in Vol. 1, Section 5.4.7. The only significant use of urea-formaldehyde or melamine-formaldehyde resins in building is for resin bonded wood application. These include counter tops, chipboard, furniture and decorative laminate. Their excellent color and high hardness make them particularly desirable for the surfaces of composites.

Like phenolics, these composites, usually with cellulose filler or cellulose plies, are generally less flammable than corresponding all wood systems and have not significantly added to the fire hazard.

#### 4.2.2.6 Reinforced Polyesters

The chemistry, properties and flammability aspects of polyesters are discussed in Volume 1, Section 5.4.2.

As indicated in Table 4.2(1) (Section 4.2.2), glass reinforced unsaturated polyesters (GRP) are one of the smaller (although significant) volume polymers being presently used in building and construction. Because of GRP's fast rate of growth, however, it is predicted that it will be the second largest volume resin system by 1980.

Table 4.2 summarizes the major areas in which unsaturated polyester resins are used in building. Since these resins are used almost exclusively with glass reinforcements and often with additional inorganic fillers, these figures refer to the weight of the total finished formulation. The consumption of resin is considerably lower than indicated in this table.

*Table 4.3. Major Applications for Reinforced Polyesters in Building and Construction\**

Application	Consumption (1000 Metric Tons)
	1975
Glazing and Skylights	7.5
Panels and Siding	47.7
Pipe, Conduit, Ducts and Tanks	52.2
Plumbing and Bath Fixtures	23.0
TOTAL	130.4

\* Anon, Modern Plastics 53 (January, 1975)

More than 80 percent of the reinforced polyester formulations used in building are in the two categories (a) panels and siding and (b) pipe, ducts and tanks. (Table 4.3). Plumbing and bath fixtures are perhaps the fastest growing application. Most, if not all, of the polyester formulations must meet some flammability requirements. The widely used test requirement for glazing, panels and siding is the ASTM E84 tunnel test with the more fire-retardant formulations exhibiting flame spread ratings of 25 or less. The flammability test most generally used for conduits and ducting is the Factory Mutual Approval Standard #4922. This is a fairly stringent test because of the relatively high rate of air-flow required to be drawn down the duct during the test conditions. The flammability test (IATMO PS11-71) required for plumbing and bath fixtures is not as stringent as FMAS #4922. IATMO PS11-71 simulates the exposure of a plumber's blow torch to the backside of the fixture for a limited time. The material is considered to be satisfactory by this test if flame extinguishes within 3 seconds after a second consecutive 30 second ignition of the test specimen using a 1 inch Benzomatic flame. A moderate loading of 50 percent

alumina hydrate in a thin layer of resin applied to the exposed side of the bath fixture is usually sufficient to allow passage of this test.

The flammability hazards associated with GRP materials in construction applications are incompletely defined at this time. Generally, a high degree of fire retardance can be incorporated into unsaturated polyester compositions using present technology.

### 4.2.2.7 Acrylics

Acrylic polymers (polymethyl methacrylate is the most widely used member of the class), are reviewed in Volume 1, Section 5.3.4. Clarity, light and weather stability and ease of fabrication are properties that make these materials attractive. More abrasion-resistant materials have recently been introduced.

Polymethyl methacrylate is comparable, in burning, to polyolefins such as polyethylene. It, however, has a smaller tendency to form smoke and drips less during burning than polystyrene or polyolefins. Halogen and antimony compounds have been used to reduce burning rates and ease of ignition (Howarth, 1973). These tend to increase the level of smoke produced. There has been less emphasis on fire retarding polymethyl methacrylate than many other polymers since excellent transparency and aging characteristics are prime properties for most applications and fire-retarding additives usually detract from one or both of these properties.

In residential housing, the acrylics are used in a limited way as room dividers, in lavatories, in plumbing fixtures and in lighting fixtures. They may be clear or transparent, flat or corrugated, in sheet or molded form. Fire hazards depend on the specific use, configuration, ignition potential, adjacent materials and amount of materials used.

Acrylics are used extensively in commercial displays and in innovative architectural and structural uses. Examples of the latter and the potential fire hazard of some such uses are the recently destroyed U.S.A. pavilion at the Montreal Expo (Anon 1976) and the 1973 Summerland fire on the Isle of Man (Lathrop 1975).

### 4.2.2.8 Nylon

Nylon is the generic name for synthetic polymers with amide groups occurring repetitively in the main chain. (See Volume 1, Section 5.3.5).

The plastics properties of 20 variants of aliphatic nylon are tabulated in the 1974-1975 Modern Plastics Encyclopedia, pages 551-552.

Nylon plastics play a very small role in housing and other buildings. Their use is generally in small molded parts such as window and door hardware, spigots, valves, and components of appliances. Nylon film has been proposed as air ducting.

In many tests, nylon plastics exhibit low flammability. Their ability to self-extinguish after exposure to an ignition source is due to their tendency to drip when ignited; dripping removes the flame front and hot polymer from the burning part. If dripping is prevented, the nylon burns with a smoky flame.

Fire-retarded nylon formulations generally incorporate phosphorus or halogen-containing additives with or without addition of antimony or iron oxides. Under some circumstances, halogens can greatly increase the flammability of polyamides, presumably by greatly accelerating the degradation to volatile fuel fragments. The addition of drip promoters, such as thiourea, has been proposed. Hydrated alumina has also been used as a fire retardant. None of these systems prevents burning in a fully developed fire.

Many molding and extruding compositions contain glass fibers or particulate mineral fillers (as much as 60 percent by weight) to enhance certain engineering properties. Such filled materials can burn more readily than the unfilled counterparts because the fillers tend to reduce dripping. The highly filled materials, however, have lower fuel value.

The nylons are currently used in relatively small items and these have not, in themselves, posed serious fire safety problems. However, as larger items, e.g., tanks, large castings, and other structural applications, are being considered, more attention needs to be given to analysis of the fire hazards that might be introduced.

#### **4.2.2.9 Epoxy**

Epoxy resins as a class of polymers are reviewed in Volume 1, Section 5.4.3. These materials, used in relatively small amounts, are thermosetting resins. They are used principally in sealing of pipe joints, as plastic-based paints, mortar for bonding either new or old concrete and as epoxy composites in electrical applications.

Flammability characteristics can be significantly improved by the addition of halogen and antimony compounds, the former either as an additive or as a copolymer. The halogen compounds generally increase the tendency to smoke during burning. Epoxy resins are frequently filled heavily with inorganic fillers. Hydrated alumina as a filler can lessen flammability.

Little or no fire hazard is introduced by epoxies in construction due to the nature of the compositions, their usage, locations, and quantities.

#### **4.2.2.10 Polycarbonates**

Polycarbonates are a class of polymers generally known to be extremely tough. Particularly, they combine clarity with high impact resistance. These materials are discussed in Volume 1, Section 5.3.9. The polycarbonates are significantly less flammable than unmodified styrene, olefin or acrylic polymers. Their fire resistance has been improved by the addition of halogenated materials in the form of additives or as copolymers.

Polycarbonates are just entering the residential housing market as glazing, beginning with the replacement of the glass in storm doors. Toughness, clarity, and resistance to impact are the key properties that make polycarbonates attractive. They have broader use in glazing in banks or areas of high vandalism such as

schools. Many of the housings, handles, etc. of small appliances and tools are made of polycarbonates.

In applications where large areas of polycarbonate glazing is contemplated, an analysis should be made of the effect of its use on the fire safety of the entire system.

#### 4.2.2.11 Acetals

The acetals are linear polymers of formaldehyde, i.e., polymethylene oxide.

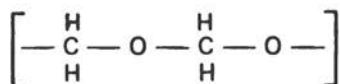

They are used in relatively small amounts in housing. Acetal chemistry and flammability properties are reviewed in Volume 1, Section 5.3.7.

The acetal plastics are strong, stiff and tough. They are considered as engineering resins because of their predictable design, processing and end use characteristics.

Acetal parts find significant residential building applications in plumbing fixtures (ballcocks, faucets, showerheads, etc.) (Baldwin, 1975), window and door hardware, and handles and mechanical components in appliances.

The acetals are easily combustible. They have a low oxygen requirement, burn with little smoke and a non-luminous flame. The amount of dripping depends on resin molecular weight and percent of filler present. The products of combustion are carbon dioxide, water and some carbon monoxide.

Phosphorous based systems have been cited as flame retardants for acetals (Pearce 1973). No commercial success has been achieved in this direction. On the other hand, acetals are used in relatively small parts where they do not present major fire hazards.

There is a trend toward using acetals in larger items, e.g., lavatories. When acetal parts become larger, their fire hazard should not be ignored. There is also increased usage of acetal for water lines in mobile homes.

#### 4.2.3 Foams

The fatal fire in Kansas City in 1972 involving unprotected polyurethane foams, and the ensuing class action suit and Federal Trade Commission action (FTC 1975) were the start of a new awareness and extensive activity with regard to safe use of polymeric materials and particularly foam materials in buildings.

Rigid foams of various types are used in buildings for insulation and increasingly for structural and decorative applications. The increasing need for energy conservation will probably further accelerate the utilization of these efficient insulators. Flexible foams are extensively used for mattresses, furniture cushioning and carpet underlay. Flexible polyurethane foams for cushioning represent the largest application of foams in housing and furnishings. Rigid polyurethane foams for insulation,

polystyrene foam for insulation, structural polyurethane foam, polystyrene foam, polyvinyl chloride foam and polyolefin foam are used in lesser amounts. Foam rubber has been extensively used for mattresses, furniture cushioning and rug underlay but its role in these uses is decreasing. Urea-formaldehyde and phenol-formaldehyde foams for insulation are beginning to appear in housing applications.

#### 4.2.3.1 Polyurethane Foam

##### 4.2.3.1.1 Usage

Polyurethane foams are cellular plastics formulated by the reactions of two liquids (a polyol and a polyisocyanate) in the presence of pneumatogens, catalysts, surfactants, and special additive chemicals such as fire retarding agents. By altering the polyol, the type of isocyanate and other ingredients, widely different foams can be made. They can be flexible, semi-flexible, or rigid with densities ranging from one to more than 60 pounds per cubic foot. The distinction between rigid and flexible polyurethane foams is fundamental in their properties and use, their chemical make up, and the fire safety problems associated with each. (see Volume 1, Chapter 6 and references therein). With the extraordinary variety of formulations possible, polyurethane foams can be produced to meet a broad spectrum of properties. Decisions concerning the type and quality of ingredients, including special fire retardants and foam properties are made by the individual foamers, molders and applicators in response to market demands.

Polyurethanes are currently the most efficient insulating materials on the market and the most widely used cushioning materials. Due to their outstanding functional properties and their cost competitiveness, polyurethanes have broad acceptance and market growth in housing. Table 4.4 gives usage of foams in buildings.

*Table 4.4. Usage of Polyurethane Foams in Buildings  
(Millions of Pounds 1976)\**

<u>Flexible Foams</u>	
Bedding	130
Furniture	421
Carpet Underlay	235
<u>Rigid Foams</u>	
Appliances	59
Construction	170
Furniture	30

\*Urethane '77" The Upjohn Company Polymer Chemicals Division Sales Department 479, P.O. Box 658, LaPorte, Texas 77571



For furniture use, slab flexible foam is generally produced with a density of 1 to 3 pounds/cu ft. It is then cut into cushioning for sofas and chairs. The cushioning market is now dominated by flexible polyurethane foam; it has largely replaced cotton batting, feathers, hair, springs, and foam rubber. Benefits include comfort and low in-place cost.

For bedding, polyurethane foam is reported to exhibit comparable comfort and lower cost than its two competitors, latex rubber and inner springs. It weighs 30 percent less than inner spring mattresses and as much as 50 percent less than foamed rubber. The combustibility of mattress composites is regulated by the Consumer Product Safety Commission standard FF4-72- Flammability of Mattresses.

In carpets, flexible polyurethane foam is used as pads and on foam-backed carpets. Polyurethane foam is less expensive than its competitors and has overall good use properties.

Rigid foams, like flexible foams, have a wide range of formulations, mechanical properties, and uses. For most applications, the density ranges from 1 to 3 pounds per cubic foot (pcf), but furniture and other structural applications may use foams with densities up to 45 pcf. Rigid foam has good dimensional stability, excellent insulating value, high compressive strength, relatively low water absorption, and can be molded into rather intricate shapes. It is easily produced by spray, pour-in-place, molding, continuous slab or laminating techniques and is relatively inexpensive.

For building insulation use, rigid polyurethane foam is durable, competitive in cost, and has extremely low thermal conductivity (k factor 0.18) and low water absorption. Foam has been used successfully as sprayed-on insulation for homes, mobile homes and other structures that are properly protected for fire safety. The SPI Urethane Safety Group recommends covering rigid urethane foam insulation with a suitable flame barrier as soon as possible after installation (SPI-1974).

Rigid polyurethane is the dominant appliance insulating material due to its low thermal conductivity, versatility in application (foamed-in-place, spray or slab) and the strength it provides to the structure when the foam is bonded to the inside and outside panels.

Rigid polyurethane foam is used both structurally and decoratively in densities of 4 to 40 pounds per cubic foot. It has uniform quality, can be mass produced in a variety of densities and textures, and has outstanding impact resistance. It appears in many housing applications — tables, cabinets, chair shells, picture frames, decorative beams, wall panels, etc. Some rigid foam furniture has been formulated to provide a limited degree of flame retardance; numerous programs for studying the combustibility characteristics of such foams are under way.

#### **4.2.3.1.2 Combustibility Considerations**

Presently, all polyurethane foams, whether fire retarded or not, should be considered combustible and handled accordingly (SPI 1974).



**Flexible foam** — Flexible polyurethane foams are inherently more easily ignited than rigid foams. They have an open celled structure and, because of their chemical composition, are more difficult to flame retard than rigid foams. Ignition test results for flexible polyurethane foam vary according to chemical formulation, density, nature of materials used with foam and the nature of the heat source. Some low density nonflame-retarded flexible foams with no fire-protective covering material can be ignited by relatively small heat sources. The ease of ignition of flame-retarded foams of higher density drops significantly. As flame retardance and density are increased, there is often an increase in smoke evolution during fire. Furthermore, there is a substantial cost premium for the fire retarded variety of flexible foam. While flame retarded flexible foam performs relatively well in resisting primary ignition from small ignition sources, its performance as to flame propagation varies with the composition and fire environment. Generally, once ignited, flexible foam (even fire retarded) burns rapidly with a high heat release rate, produces considerable smoke and a brown melt that may continue burning after the heat source is removed. Under other conditions, the foam retracts from the heat source or drips away from the ignition source and self-extinguishes.

**Rigid Foam** — Rigid polyurethane foam can be ignited variously by direct flame, electrical faults, hot metal objects, etc. Fire-retarded grades of rigid foam may not always resist intense heat sources, but will resist sustained combustion and initial fire propagation from small ignition sources. The role of rigid polyurethane foam in propagating a large-scale fire is not completely clear. Rigid foams produce smoke and combustible gases but generally do not melt or drip.

In general, it can be expected that foams will be totally consumed in a large fire environment. However, some fire-retarded rigid foams form considerable char that retards further combustion and insulates the substrate material.

#### **4.2.3.2 Polystyrene**

The various types of polystyrene foams, their methods of processing, their applications and general flammability characteristics are summarized in Volume 1, Section 6.3.3.

The major use of polystyrene foams in buildings is as thermal insulation. This can be in the form of low density foam boards or planks placed under concrete slabs, in various configurations of roof decks and walls or extruded foam laminated between Kraft paper. The latter composite is extensively used in wall sections of mobile homes. Foam beads are also used as fillers in concrete to produce light weight insulative concrete. Low density foam has also been used for ceiling tile.

Higher density foams are being employed in structural and decorative applications. These include TV cabinets, furniture, cabinets, drawers, doors and sidelights, decorative trim, shutters, etc. These applications take advantage of the low cost of fabrication, good appearance, good physical properties, dimensional stability, and durability of these systems.

## MATERIALS

Cellular polystyrene can be ignited by an open flame and burns rapidly with evolution of dense smoke. Even those materials containing fire retardants will burn in the presence of flame sustained by other fuels. However, some fire-retarded cellular polystyrene will not propagate flame when exposed to a small fire source such as a match, a burning cigarette, a hot wire or a bunsen burner. The material tends to "shrink" away from such heat sources prior to ignition, and unless the heat source follows the material, or other energy is applied, no ignition occurs.

Polystyrene foams have no tendency to "punk," or "glow" or smolder, and require oxygen to continue burning. Slow burning internal fires which may later kindle another fire outbreak are not characteristic of cellular polystyrene.

The fuel contribution from insulative cellular polystyrene is low on a volume basis (1400–2800 BTU/board foot vs wood at 27,000 BTU board foot). Structural foams of polystyrene (density 20–40 pcf) have fuel contributions one to two times that of wood.

The major fire hazards from cellular polystyrene are the potential for high burning rate, high smoke production and rapid flame spread. These are, of course, highly dependent on location, geometry, orientation and relationships to other materials. Ignition and burning rates are also affected by composition (flame retardants) ignition source and thermal environments.

### 4.2.3.3 Polyvinyl Chloride (PVC)

Flexible PVC foam finds its greatest utilization in coated fabrics, clothing, and seating applications, in which uses it probably has little effect upon the fire safety of residential buildings. High density foams of varying flexibility are used for flooring in residential and nonresidential buildings. As previously noted, the flammability hazard of PVC in this application varies according to the type and amounts of plasticizer used in the composition (See Section 4.2.2.1, and Volume 1, Section 5.3.3).

More recently, rigid extruded vinyl foamed shapes are finding increasing application in the construction industry as exterior and interior trim, window casing, sandwich core material and siding. About 22,000 metric tons were used in these applications in 1974. Consumption decreased significantly in 1975 (18,000 metric tons) because of the slump in the construction industry (Anon 1976). The flammability of the foamed vinyl extruded shapes is generally low because of the high density and thermal conductivity, the absence of significant amounts of flammable plasticizers and the high concentration of inert fillers generally used in the formulations.

These and similar uses for rigid vinyl foam will probably increase rapidly in the next few years.

### 4.2.3.4 Rubber

Practically any elastomer can be made into a flexible foam. These foams are used

in a variety of furnishings, the most important being mattresses, seat cushioning, rug underlay, and carpet backsizing.

When a chemical blowing agent is used in a dry-compounding recipe, the foam rubber is generally referred to as sponge rubber. Sponge rubber is made mostly from the natural polymer and from styrene-butadiene polymer, although silicone and fluorocarbon sponge rubbers are also available.

Latex foam rubber is made by beating air into compounded rubber latex. Fluorocarbons are used as (additional) foaming agents in some processes. A gelling agent such as sodium silicofluoride or ammonium acetate may or may not be used. Natural or styrene-butadiene rubber, or blends of the two are widely used.

The fire retardation of latex foam has been discussed by Hecker (1968), and that of sponge and latex foam by Fabris and Sommer (1973). The approaches used are generally the same as those employed with the same bulk (i.e., nonfoamed) elastomer. In addition, post-treatments that are similar, in principle, to those applied to wood and wood products are possible because of the cellular nature of foams.

Foam rubber (rubber latex foam) has been used extensively for furniture cushioning, mattresses, and rug underlay for over 30 years. Rubber latex foam presents a fire hazard because of relatively easy ignition, substantial burning rate, considerable smoke production and tendency to smolder. Neoprene rubber foam has been used for special applications where low flammability is required (submarines, hospital beds, etc.) but has been little used in commercial applications. It is considerably more expensive than conventional rubber foam or urethane foam. Neoprene foam is ignited less readily than rubber latex foam, but once ignited, is difficult to extinguish and produces extensive HCl and dense smoke when burning.

The use of rubber foams in housing is decreasing, being replaced in most cases by polyurethane compositions.

#### **4.2.3.5 Urea-Formaldehyde**

Urea-formaldehyde foams are made by mechanically frothing two aqueous reaction streams in a special applicator gun. Foam comes from the gun in fully expanded form. It sets in 10 to 60 seconds, cures in 2 to 4 hours and dries in 1 to 2 days.

The use of urea-formaldehyde foams for insulation of houses or mobile homes is rapidly expanding. The 1974 U.S. consumption was about 500 tons per month with expectations of doubling each year for a number of years. Outstanding properties are: relatively good fire safety (low smoke, low flame spread, and low fuel value), good insulation efficiency ( $k$  factor = 0.18 to 0.20), effective absorption of sound, pest repellent, ability to be injected into the wall in new or old housing, good flow and filling of void space, stability, and no pressure build-up (Wood 1974).

Urea-formaldehyde foams have no significant flexural strength and thus no potential as a building structure material. It is not recommended that urea-formaldehyde foam be left exposed since the material is easily damaged by

mechanical means. The installed cost has been estimated to be about 1/3 that of polyurethane foam insulation.

The fire safety aspects of these polyurea/formaldehyde foams were vividly demonstrated in an October 30, 1974 3-alarm Minneapolis home fire which demolished an attached garage and two cars. The outer wall of the house on the garage side was burned away but the fire went no further. Urea/formaldehyde foam insulation had been used in the walls and roof of the house and served as an effective fire barrier.

#### **4.2.3.6 Phenol-Formaldehyde**

Although phenol-formaldehyde foams have been known for a long time, commercial utilization has been very small. This was due to their friability and corrosivity resulting from the residue of the strong acid used in their preparation. Such foams do exhibit the normal good fire resistance characteristics of phenolic polymers but have a tendency to undergo "punk" glowing combustion. Recently, progress has been made towards overcoming these shortcomings (Wood 1974). Slabstock, spray applications, laminates, and injection molded foams are in various stages of commercial development. These foams vary from 100 percent open-cell up to 80 percent closed-cell and have k values from 0.19 to 0.23 depending upon density and temperature. Phenolic foam roof insulation is reported to be the first plastic foam to obtain a Class 1 rating for an insulated steel roof deck construction. (One hour fire resistance by standard NBS test).

#### **4.2.3.7 Polyolefin**

The outstanding properties of polyolefins as solid plastics, such as toughness, moisture resistance, chemical inertness, ease of fabrication, etc., carry over to foam applications and are responsible for rapidly increasing use of polyolefin foams in building structures and contents. Extruded low density polyethylene foams are used as carpet underlay, furniture underpadding, and community antenna television cables (Kirshenbaum 1976). Flame-retarded and glass fiber-reinforced foam systems are available and under development for frames for upholstered furniture, automatic clotheswasher lids, cabinet fronts, etc. Extruded polypropylene foams are included in the fast growing list of materials for replacing wood molding and other products such as door and window frames trim, cove and base board molding etc. (Hug 1974).

Fire safety aspects of olefin foam depend, as with other materials, on the specific use, the combinations with other materials and the fire loads in the area of use. Any use involving critical flame spread pathways and/or large areas or volumes of materials should be carefully analyzed for fire safety.

#### **4.2.4 Fibers**

Many classes of natural and synthetic fibers are used in the fabrication of in-

terior components of residential buildings (Kaswell, 1963; Harris, 1954). Their use in carpeting, upholstery, drapes, and bedding (mattress components and coverings) consumes a very high percentage of the 10 billion pounds of synthetic fibers (1974) produced annually as well as a lesser percentage of the cotton and wool produced. The rapid increase in the quantities of synthetic fibers used has caused concern as to which of these fibers may contribute to fire hazard, and what alternatives or trade-offs are possible with respect to modifying fibers with fire retardants. In the case of carpeting, some fire safety regulations have been established, and development of fire-resistant, non-toxic, low smoke, fiber-forming polymers for use in carpets has been accelerated.

The classes of fibers most widely used in residential buildings, and related situations are reviewed briefly below with regard to their potential contribution to hazard from fire, toxic gas evolution and smoke. Approaches being taken to improve fire resistance are also indicated.

#### 4.2.4.1 Cellulosics

The cellulosic fibers include cotton, and various forms of rayon. The cellulosic fibers burn, but do not smoke excessively. The toxicity of combustion or pyrolytic products has not been a special problem. The fibers ignite when a flame touches them, and they are rapidly consumed leaving a soft gray ash. Decomposition starts at about 150°C (300°F); this temperature may depend on other materials present, including, for example, the dyes used to color the fibers and finishes.

In many residential building applications, cotton fiber is used by itself, as in mattress padding, some forms of carpets or rugs, or upholstery. In some applications, cotton is blended with other fibers such as acrylics or polyester, e.g., for draperies (curtains), upholstery fabrics, and bedding. Because of the relatively low cost of short, low strength cotton fibers not suitable for textile use, this grade of cotton has been used extensively as padding in mattresses and cushions, either alone or in combination with foams. The ignition of bedding or upholstered furniture by small ignition sources such as cigarettes is a frequent source of accidents, and a well documented origin of many building fires, in some cases involving cotton batting. To minimize the probability of such accidents, fire retardants are necessary. Suggested chemical retardants for cotton batting range from a combination of borax and boric acid (not durable) through phosphate and antimony salts applied with resin binders (semidurable) to complex allegedly carcinogenic finishes such as APO [tris (i-aziridiny)l-phosphine oxide] and THPC [tetrakis(hydroxymethyl)phosphonium chloride] which are durable to multiple laundering. In the case of mattress and upholstered furniture padding, the less durable finishes can be used since the product will not be exposed to laundering. The more durable finishes are needed in applications such as upholstery fabrics, carpeting, drapes and curtains, where laundering or dry cleaning during the life of the material must be expected.

As discussed in Volume 1 — *Materials*, flame-retardant finishes are used exten-

sively but some questions have been raised recently concerning possible toxic gas evolution in the combustion of cotton treated with the more durable APO and THPC finishes. Efforts are currently in progress to establish the toxicity hazard of these finishes.

New fire-retardant finishes for cellulose have been developed recently. Some are reactive phosphonates. One commercial process is based on the polymerization of a vinyl phosphonate on the fabric. Generally, good flame resistance is obtained on cellulose through the insolubilization of 2 to 4 percent phosphorus, depending on the particular fabric treated. Frequently, nitrogen-containing coreactants are used in conjunction with phosphorus compounds.

### 4.2.4.2 Wool

The use of wool fibers in residences has been decreasing steadily. Small volumes of wool fiber are used for carpeting and minor amounts are used for upholstery fabrics. Wool starts to decompose at 135°C (275°F), chars at 300°C (570°F), and melts at higher temperatures. Wool is considered less flammable than the cellulose but will support combustion and can yield toxic products including hydrogen cyanide. Because of the curtailed use of wool, only modest efforts have been made to develop flame retardant treatments for it. Some organophosphorous compounds and some salts of polyvalent metals have proved effective in decreasing the flammability of wool fabrics. The flammability of blends of wool with cellulose and with synthetic fibers is discussed in Section 4.2.4.7.

### 4.2.4.3 Nylon

Nylon is a generic term for linear aliphatic polyamides in which recurring amide groups are an integral part of the polymer chain. There are two commercially important nylon fibers; nylon 6-6, a condensation polymer of hexa-methylene diamine and adipic acid, and nylon 6, made from polymerization of  $\epsilon$ -caprolactam.

Nylon fibers are thermoplastic, and may not support combustion in some configurations, as they tend to shrink away from the ignition source. The melting and dripping characteristics give nylon some resistance to ignition. Improved flame resistance has been claimed for some modified nylons, but not without causing problems of performance, durability, and cost.

### 4.2.4.4 Acrylics

Polyacrylonitrile fibers containing more than 85 percent by weight of acrylonitrile units are covered by the generic term "acrylic." If they contain less than 85 percent by weight of acrylonitrile units, they are termed "modacrylic." Both fiber types are used extensively in upholstery and drapery fabrics, and in carpeting.

The modacrylic fibers currently produced are copolymers of acrylonitrile with halogenated monomers. Modacrylics melt but do not generally support combustion. The acrylics melt and ignite, burning vigorously with a sputtering effect producing a



dense black smoke. As with other nitrogen-containing fibers, the amount of HCN produced on burning is dependent on the burning conditions.

#### 4.2.4.5 Polyesters

Polyester fibers are obtained from linear polycondensation products of a dihydric alcohol with terephthalic acid. As in the case of nylon, thermoplastic polyester fibers tend to melt away from small flame sources, and may self-extinguish by dripout of the molten material. The presence of even a small amount of non-thermoplastic fiber, such as cotton, interferes with this melt-drip phenomenon; burning is then sustained.

Polyester fibers are used in carpeting and to some extent in upholstery fabrics. Blends of polyester and cotton or wool are used for upholstery fabrics and in bedding (sheets, pillowcases, lightweight blankets, etc.). Polyester fibers blended with cotton or wool provide the material for very widely used fabrics. These blends, however, burn as vigorously as untreated cotton (see 4.2.4.7, Fiber Blends). Flame retardants used for polyester fibers have been generally bromine compounds — a modified fiber is available in which a brominated diol replaces part of the ethylene glycol in the polyethylene glycol terephthalate. This approach is effective for some products. Bromine can also be introduced by using an additive in the molten polymer prior to fiber formation, or by applying bromine compounds topically after the fabric is made.

#### 4.2.4.6 Polyolefin

Olefin fibers are composed of recurring units of ethylene, propylene, or other olefins. Polyethylene and polypropylene are produced commercially in fiber form. Polypropylene is finding increasing use in upholstery fabrics. Because of the hydrophobic nature of polypropylene, fabrics made from it are outstandingly stain resistant and easy to clean. Carpets in areas of outdoor exposure, utilize this class of fibers (indoor-outdoor carpet) (Ivett 1964).

Polyolefin fibers melt at low temperature, and rapidly shrink away from the flame source, often curling before the flame touches them. Thus, they ignite with difficulty, but if ignited, can burn rapidly with low viscosity flaming drops. Polypropylene has a higher melting point than polyethylene, but behaves similarly with respect to flammability. No commercially successful modifiers or treatments are currently known which significantly improve flame resistance of olefin fibers.

#### 4.2.4.7 Blends

Many fabrics used today are composed of yarns made by blending two or more fibers. The technology of blends has become an excellent example of the textile industry's skill in the utilization of available materials (fibers) to achieve new and improved fabrics. The flammability of blends has been studied recently as a consequence of emerging regulations and of the textile industry's increasing activity in the area of textile flammability. These studies have shown that the flammability

behavior of blends can not be predicted from knowledge of the flammability behavior of the individual components.

The physical and chemical interactions of different fibers in blends, when exposed to elevated temperature, pose complex problems which are still the subject of extensive investigations.

In residential applications blends of synthetic fibers are found in upholstery and drapery (curtain) fabrics, while blends of synthetic and natural fibers (e.g., polyester/cotton) are primarily used in bedding (sheets, blankets, spreads, etc.). In Volume 1 — *Materials*, problems of various blends are discussed in detail. Suffice it to say that an unsatisfactory situation exists in attaining fire resistance in fabrics made from fiber blends.

#### 4.2.5 Elastomers

The general types of elastomers and their fire safety characteristics have been discussed in Chapter 4 of Volume 1 — *State of the Art: Materials*. The fire safety aspects of elastomers have been reviewed by Fabris and Sommer (1973).

Elastomers play a relatively small role in housing construction where they are mostly used in floor tiles, weather stripping, gaskets, expansion joints, sealants, and electrical insulation. Elastomers are also used as exterior building finishes in roofing applications. In this application, membranes are sprayed on or laid in sheets with lapped bonded joints. Perhaps more important from a fire safety point of view is the use of elastomers in furnishings. In these applications elastomers are used mainly in the form of foam rubbers (see Section 4.2.3.4). Chief uses are in mattresses, cushioning, and carpet underlay. Also, most of the woven fabrics used for upholstery are coated with styrene/butadiene rubber latex.

#### 4.2.6 Coatings

Included in this section are paints, enamels, varnishes and lacquers. Tiles, coated paper, plastic sheet, veneers, etc., are included under the appropriate plastic composition.

Millions of pounds of polymeric materials are used in interior and exterior applications for protection and decoration. There are numerous treatises on the composition and application of coatings in buildings (Myers and Long, 1975). These, however, give little or no consideration to the fire safety aspects of such coatings. Much of the early interest in flame spread measurements of materials was directed at coatings and such data on many coatings applied to various substrates are available (Gross and Loftus, 1958; Eikner and Peters, 1963).

Christian (1974) has pointed out the critical importance of the interior finishing materials (walls and ceilings) on fire safety dwellings. It was reported that fire spread by combustible finishing materials contributed to death in more than half of all fatal fires. Since decorative and protective coatings are a part of most interior finishing systems, it is important that their effects on overall fire safety be defined.



From a fire safety view, coatings can be divided into three general classes: (1) conventional (conventional paints, varnishes and enamels), (2) fire-retardant coatings (generally formulated with halogen-containing binders with or without special fillers), (3) intumescent coatings (designed to foam on application of flame for development of adherent fire resistant insulated cellular char).

Fire safety characteristics of conventional coatings, as measured by laboratory flame spread tests, depend strongly upon the coating composition, type and density of the substrate and the thickness of the coating (Gross and Loftus, 1961). On plywood substrates, lacquers and shellac increased the surface flammability while other decorative coatings had little effect or slightly decreased flame spread (Eickner). With latex and flat alkyd paints in thicknesses above 250 sq ft/gal on a hardboard substrate, the flame spread rate was reduced by factors of 3-5 over the uncoated board. On noncombustible substrates (steel cabinets), flammability increased with the thickness of the coating film.

The advantages and limitations of "Fire-Retardant Coating" have been recently summarized (Clark 1975). A number of very effective intumescent coating systems are commercially available but general use is limited by their relatively high cost, thickness required and shortcoming in some coating properties of some systems. The outstanding advantages of such coatings have been demonstrated in numerous large-scale tests. For example, in 1973, an intumescent system was applied to one stall in a 40-year old race track barn. Three bales of hay were ignited in the stall and allowed to be completely consumed. The flames reached 15 feet but the stall was little damaged and the fire did not spread.

More consideration should be given to the use of such coatings in areas of potential easy ignition.

#### 4.2.7 Asphalt

Asphalt is a black to dark brown solid or semi-solid, usually somewhat sticky. It is predominantly a mixture of high molecular weight hydrocarbons.

Asphalts occur naturally (with or without mineral matter) and are also obtained as a by-product from the refining of certain crude oils. Bitumen is a broader term and includes tar and pitch. Asphalt in the form of shingles, felts, roll roofing and built-up roofs covers most of the roofs in this country. Asphalt shingles and roll roofing usually contain a coating of coarse incombustible mineral granules. These prevent sticking, increase durability by screening ultraviolet light and add to the fire resistance. Aggregate is also used as the top course on coal-tar-pitch built-up roofs for the same reasons.

Asphalt burns with a dense smoke, much like polystyrene. It can spread a fire by flaming drips and can generate combustible volatiles that propagate a fire under a roof.

## 4.2.8 Conclusions and Recommendations

### General Conclusions

Wood is the polymeric material used in the largest volume in buildings and generally makes the biggest fuel contribution in a fully developed fire. However, wood is not necessarily the greatest contributor to hazard. Most often other materials such as paper, fabrics, or synthetic polymers are the first to ignite or are responsible for the initial spread of a fire or may be the source of hazardous combustion products. In general, the fire hazards of wood are recognized and our actions and reactions have adjusted thereto.

The use of synthetic polymers in many areas offers cost savings and added utility, comfort and appearances that would not otherwise be available. This results in a strong and viable pressure for proliferation and expansion of uses of such materials.

Synthetic polymers generally burn differently than the materials they replace and thus present a different fire hazard. The fire hazard from any particular polymeric material, natural or synthetic, is highly dependent on its specific use. This includes design of the system, amount used, location of use, other materials involved, etc. We have learned to control the use and make acceptable risk/benefit judgments with other combustible materials (gasoline, natural gas, wood, candles, paper, cotton, wool, etc.) and need the basis for doing the same with polymeric materials use in buildings and furnishings.

### Specific Conclusions and Recommendations

#### Wood and Wood Products

*Conclusion* — Two problem areas that are not generally recognized are (1) the ease of ignition and high burning rate of unbacked thin plywood and (2) the loss of fire retardancy of shredded waste paper insulation with time and in general, the poor quality assurance of such products.

*Recommendations* — (1) Codes should prohibit use of unbacked or insulation-backed plywood less than 3/8 inch thick on walls or ceilings. (2) Define more specifically the hazards in currently available waste paper insulation products. Develop specifications and quality control methods for a safe product if feasible. If not feasible, ban the use and create incentives for development of a low cost, reliable, fire safe system.

#### Plastics

*Conclusions* — Plastics have many desirable cost and property attributes. The variety of uses and the amounts are increasing. This could lead to potential fire safety problems. Major areas of concern in plastic utilization are: plastic furniture, wall coverings; grouped electrical and communication cable insulation, particularly in vertical chases; and unconventional building construction using large surfaces of plastic.

## BUILDINGS

*Recommendations* — Continue full-scale testing of furniture and systems that contain plastic. Continue development of methods of appraisal of fire safety of wall systems and insure thorough testing of new systems. Develop extinguishment and/or fire-stopping systems for grouped insulated cables. Require large scale testing of new construction systems such as air supported structures and plastic glazed structures.

### Foams

*Conclusions* — Polymers in foam form burn faster than in the solid form. Flexible foam cushioning systems have an excellent cost relative to performance measured by comfort and durability but they have been responsible for much damage and loss of life in fires. This is generally associated with the use of smoking materials. Foam-cushioning systems are being studied extensively from the stand-points of design, materials and testing.

*Recommendations* — Test foam insulation systems on full prototype scale prior to use in buildings. Continue studies directed at safer cushioning systems including cover fabrics, heat sinks, fire barriers and even entirely new foam types. Carefully appraise all structural foam applications for fire safety; test on full prototype scale if necessary to obtain reliable fire safety data.

### Fibers

*Conclusions* — The use of fibers, and especially synthetic fibers, in buildings is increasing, primarily in carpeting, upholstery, and drapes. The flammability characteristics of synthetic and natural fibers vary widely but fire safety is highly dependent on the specific composition, design and use. Prototype or full-scale testing is usually necessary to define the fire safety of fiber-containing systems. Fabrics, especially in upholstery and drapes, are often the "first-to-ignite" and thereby are responsible for initial spread of a fire. Fire resistance is more difficult to attain in fabrics made from fiber blends.

*Recommendations* — Continue flammability studies on systems using upholstering fabrics. Consider the extent of use and types of fiber-containing systems in assessment of the fire safety of specific building occupancies.

### Elastomers

*Conclusions* — Elastomers (other than foams) are relatively little used and present no significant fire hazard per se in building and furnishings.

*Recommendations* — When elastomers are used as adhesives or sealants, the hazardous result of functional failures in a fire situation should be considered. (Examples: adhesively bonded gypsum board falling and exposing a flammable substrate; melted sealants allowing smoke penetration).

### Coatings

*Conclusions* — Coatings can increase flammability depending on the coating and

the substrate. Intumescent coatings can be an effective means to protect flammable substrates.

*Recommendations* — Encourage research and development for improvement in cost and durability of intumescent coatings.

### 4.3 Building Structure

#### 4.3.1 Classification of Building Construction

The determination of the relative risk of a building with respect to fire resistance has been the desired goal of building and code officials and insurance underwriters, for some time. For this reason, the number of construction classifications has proliferated. At one time, there were only two classifications: "fireproof" and "nonfireproof." The term "fireproof" was misleading, however, as it conveyed a false sense of security. Consequently, the term "fire resistive" was coined to promote a more realistic assessment of the resistance of certain buildings to the effects of fire. The development of new materials and new construction methods led to the definition of five generally accepted basic types of construction: fire resistive, noncombustible<sup>1</sup>, heavy timber, ordinary, and wood frame. An additional classification, "unconventional" has been added here to cover the new approaches that are under various stages of development and use.

##### 4.3.1.1 Fire Resistive Construction

Fire resistive construction is defined by NFPA 220 (McKinnon 1976) as... "that type of construction in which the structural members including walls, partitions, columns, floors, and roofs are of noncombustive or limited-combustible materials and have fire resistance ratings not less than those specified. (Test Procedure NFPA 251).

A building, classified as being fire resistive construction, can resist structural damage from fire more than any of the other building construction types.

Buildings of fire resistive construction (4- and 3-hr fire resistance rating, see Chapter 5) are commonly referred to in building codes as Type I and Type II or Type A and Type B.

It must be recognized that fire resistive building construction does not necessarily assure safety to life and property in case of fire. A fire resistive building will not contribute fuel to a fire; also, the probability of collapse due to fire damage is small. However, due to the building contents, interior finish, etc, numerous case histories of fires in fire resistive buildings describe high loss of life and severe property damage, while the building required only redecoration to restore it to full use.

---

<sup>1</sup> The NFPA uses the term "noncombustible/limited-combustible."

#### 4.3.1.2 Noncombustible/Limited-Combustible Construction

The term "Noncombustible".....has been defined as a material which, in the form in which it is used and under the conditions anticipated, will not ignite, burn, support combustion, or release flammable vapors when subjected to fire or heat.

The new term "limited-combustible".....has been defined in terms of potential heat value, flame spread rating and thickness of combustible coating to include gypsum board, painted plaster and comparable materials. (NFPA 220).

In noncombustible or limited-combustible construction, the walls, partitions and structural members are of noncombustible or limited-combustible materials. Although these materials do not contribute fuel to the fire, the unprotected structural members may be damaged by heat. The main feature of noncombustible or limited-combustible construction is its lack of fire spread potential. Typical of unprotected noncombustible or limited-combustible construction are metal-framed, metal-clad buildings. The principal danger from unprotected noncombustible or limited-combustible construction is the potential for collapse.

#### 4.3.1.3 Heavy Timber Construction

In heavy timber construction, the columns, beams, and girders are commonly heavy timber with thick wood floors and roof construction built of heavy timber without concealed spaces.

For a building with wood columns to qualify as heavy timber construction, the columns cannot be less than 8 inches in any dimension. Wood beams and girders cannot be less than 6 inches in the least dimensions, nor less than 10 inches in depth, and floors must be 4 inches thick. Timber arches or trusses may be used to support roof loads if they are of certain minimum dimensions.

In the United States, buildings of this type had their origin in New England to provide satisfactory structures for the textile industry. Heavy timber construction for a time was threatened with obsolescence because of the availability of other structural materials. However, glued laminated lumber structural elements have revitalized this basic construction classification. Some of the modern-day structures employing glued laminated timbers meet or exceed the minimum timber size requirements of the definition. Heavy timber construction, by virtue of the size and mass of planks and timbers, provides a slow-burning structure. Potentially, the weakest points in the fire resistance of heavy timber construction are the edges, joints, and connections of timber members.

#### 4.3.1.4 Ordinary Construction

NFPA 220 defines ordinary construction as: ".....that type of construction in which *exterior bearing walls* or bearing portions of exterior walls *are of noncombustible or limited-combustible* materials and have minimum hourly fire resistance ratings and stability under fire conditions; nonbearing exterior walls are of *noncom-*

*bustible or limited-combustible materials, and roofs, floors, and interior framing are wholly or partly of wood."*

The ability of ordinary construction to withstand an interior fire or to confine the spread of fire to one area is no better than the degree of protection given to the combustible components of the roof, floors and interior framing.

Interior sheathing for wood floor and interior wall framing offers varying degrees of protection for wood or other combustible structural members. For example, some types of gypsum wallboard, when used over wood joist framing will produce an assembly having a fire resistance rating of up to 2 hrs.

Ordinary construction at one time was the most common type for commercial and office buildings, multiple-occupancy buildings (hotels, apartment houses), schools, churches, and other institutional occupancies. Buildings of this type predominate in congested areas of many large U.S. cities and most are deficient in providing protection for life safety.

Building codes place limitations on heights and areas of buildings of combustible construction. Hospitals and other institutional buildings of combustible construction where occupants must be assisted in leaving the building are specific occupancies with height and area limitations.

Typical examples of materials used in exterior bearing walls of ordinary construction are brick, reinforced concrete, and concrete or other masonry units. Framing may be wood columns, beams, girders, and joists. Wood floors consisting of a subflooring overlaid with finish flooring for a total nominal thickness of 2 inches are common in ordinary construction. Subflooring topped with laminated wood sheets and covered with asphalt, rubber, or plastic tile, or other decorative coverings is much in use today.

#### **4.3.1.5 Wood Frame Construction**

Wood frame construction is defined by NFPA as: .... "that type of construction in which exterior walls, bearing walls and partitions, and floors and roofs and their supports are wholly or partly of wood or other combustible material, when the construction does not qualify as heavy timber construction or ordinary construction."

Wood frame construction, commonly called "frame" construction, differs from ordinary construction only with respect to exterior wall construction, ordinary construction requiring noncombustible exterior walls.

The basic form of exterior wood wall construction is vertical wood studs, commonly 2 X 4 inches with 1-inch boards nailed to the studs and with an exterior covering of wood siding (sheathing). There are many variations of exterior wall construction. Various composition boards may be used in place of wood sheathing and many exterior wall covering materials are used.

#### **4.3.1.6 Unconventional Construction**

A number of unconventional building constructions using polymeric materials

have been proposed and some carried to prototype or development status. These include various approaches to continuously foamed structures, geodesic designs using plastic or foam panels, many types of interlocking composite panels, etc.

One of the simplest and most rapidly growing of unconventional structures is the air supported structure. These structures are made from a fabric-reinforced plastic film that is anchored and kept inflated to a pressure of about five pounds per square foot by electric blowers. Standby auxiliary engines are usually available in case of power failure. The films most commonly used have been plasticized polyvinyl chloride reinforced with nylon fabric. Such compositions are reported to last up to 10 years. Greater durability is claimed for fiberglass fabrics coated with fluoropolymers. There are some sophisticated structures that have a double walled insulative airspace, a metallized coating to further enhance thermal efficiency and an exterior of self-cleaning and durable polyvinyl fluoride film.

The use of air-supported structures is increasing rapidly due to the relative low cost per square foot, the large unobstructed floor areas possible and the speed of construction. Current usages range from short-term uses, such as temporary garages, warehouses, and construction area covers, to enclosed tennis courts, other sports facilities, and even schools, shopping malls and exhibit halls. With restraining cables anchored to the foundation to increase resistance to wind forces, ground level air-supported structures are practically unlimited in possible span. One of the largest completely air-supported structures built to date covered a 1.7 acre power plant construction site in Canada.

The use of this type of construction for the more permanent applications will probably increase rapidly as the technology develops and confidence in the durability and maintainability increases with experience.

The fire safety of such structures has received little attention. Certainly, the flammability of some of the composites could be high while others such as fluoropolymer and glass fiber would be low. The total fire load per square foot is relatively very low, but an extremely fast combustion which could occur in such a configuration could impose a severe threat. Also, there is a danger of collapse if a sufficiently large hole is produced by the fire. Some large-scale tests seem indicated to help define the extent of the problem.

#### **4.3.2 Building Elements**

Each new building is unique. The variety and complexity of buildings is great, and the components that are combined in their construction are numerous and varied. Major elements of building construction that are of interest with respect to fire protection are structural frame, exterior walls, interior walls and partitions, floors, and ceilings.

##### **4.3.2.1 Structural Frame**

The structural frame is the skeleton of the building which supports the dead load



of the building itself and superimposed live loads, such as people, building contents, wind, snow, and ice. Building practices have resulted in several reasonably well-defined framing systems that utilize steel, concrete, and wood (McKinnon 1975). These include: A structural steel frame work supporting a reinforced concrete floor or a precast concrete floor; a slab, beam girder, column system cast monolithically of reinforced concrete; large wooden members of heavy timber construction for industrial buildings and warehouses; lightweight, wood frame construction.

### 4.3.2.2 Exterior Walls

The primary function of exterior walls is to protect the inside of the building from the elements. Walls of many buildings also support a vertical load such as floor and roof framing systems.

Load-bearing exterior walls are generally constructed of masonry, such as stone, brick, concrete block, or a combination of these materials. Brick veneer is sometimes used as a facing in wood frame construction. In this case, the wood studs support the applied loads, while the veneer produces an attractive, useful exterior surface.

Exterior walls can also be constructed of reinforced concrete. The reinforced concrete can be either poured in place or precast.

Typical of exterior walls in wood frame constructions are:

**Siding:** Shingles (wood, asbestos-cement), clapboards (wood, plastic, or metal).

**Brick Veneer:** Consists of a single thickness of brick around a wood-framed structure; it depends upon bonding to the wood structure for stability. This gives a building the appearance of standard brick construction, but is not in any way equivalent. It does provide some degree of protection against external exposure, such as from grass fires.

**Metal-Clad Construction:** A sheet metal covering is nailed over wood siding. While the metal covering may prevent ignition of the wood by small flames, it has relatively slight value in protection against exposure to a large-scale fire.

**Asphalt-Composition Siding:** A finish simulating brick or stone that is similar to the material used for roofing. Such compositions have satisfactory fire retardant properties for use as a roof covering, but test data are lacking as to fire retardant properties when used on exterior walls. In this vertical configuration it is more susceptible to ignition and sustained combustion.

**Stucco:** Cement plaster on lath over wood frame construction.

**Prefabricated Plywood Walls:** These walls are substantially the equivalent of the basic type of wood studs, boards, and wood siding.

In many buildings, exterior masonry walls are nonload bearing, i.e., they support only their own weight. The floor and roof framing is supported by columns and framing that transfer the loads to the foundation. Usually, each story of the exterior wall is supported on spandrel beams which frame into the columns.

**Curtain walls:** Curtain walls are nonload bearing, prefabricated exterior wall



panels that are supported by the structural frame of the building. Generally, when a skeleton frame is used, whether it be structural steel or reinforced concrete, curtain walls are used as the exterior walls.

There are a wide variety of materials and types of construction for curtain walls. Aluminum and stainless steel curtain walls are, by far, the most popular. In addition copper and copper alloys, carbon steel, galvanized metals, porcelain enamel finish, concrete, glass, and plastics are used. The types of curtain wall that are of principal concern from the fire safety viewpoint are the various light weight, combustible prefabricated types.

A complete curtain wall consists of a panel with finished outside and inside surfaces, insulation, and means of attachment to the building frame. Broad areas of windows have been common in this type of wall.

Combustible curtain walls or components thereof made of, e.g., acrylic or fiber glass-polyester can lead to rapid vertical propagation of fire up the outside of the building. Also, from a fire safety viewpoint, the method of attachment and the details of construction between the panel and the floor slab are important. There is usually a space between the end of the slab and the inside of the curtain wall. Unless adequately fire-stopped, this space acts as an avenue of vertical fire propagation.

### 4.3.2.3 Partitions

Interior partitions may be either bearing or nonbearing. Bearing partitions are common to older construction systems.

Partitions can be installed using a number of materials. Wood stud and gypsum board or plaster is a very common type of partition. Masonry units, such as concrete block, structural clay tile, terra cotta, and gypsum block are also common. In mobile home construction, partitions are generally thin (less than  $\frac{1}{4}$ " ) plywood directly over metal or wood studs without gypsum board backing. Such partitions can and do spread fire rapidly.

The open space flexibility of much modern nonresidential construction employs interior partitions that can be installed at any location convenient to the occupant. These partitions, called movable partitions, are often made of steel studs and gypsum board. Vinyl coated gypsum board is being increasingly used for this.

In buildings, the interior partitions act as barriers to the spread of fire. However, in order to protect certain areas more completely than would be possible with ordinary partitions, fire walls and fire partitions are constructed.

Proper construction techniques of these barriers can provide effective protection against the spread of fire.

In commercial structures some acrylic, styrenic, glass-polyester, safety glass, and rigid vinyl partitions are used for aesthetic and architectural effects.

### 4.3.2.4 Interior Finish

The interior finish of a structure is one of the main elements determining the fire

## MATERIALS

hazard of a building. By interior finish is meant the exposed surface of wall, ceiling and floor.

There are many types of interior finish materials in general use. These include plaster, gypsum wallboard, wood (and fire retarded wood), plywood (and fire retarded plywood), fibrous (cellulosic) board and tile, vinyl-coated hardboard, vinyl-coated gypsum board, ceramic tile, plastic tiles, decorative glass and a wide variety of wall papers and other coatings. Paints, varnishes, mastics, etc., should also be included along with the substrates to which they are applied. Use of exposed polyurethane or polystyrene foam as an interior surface is now contrary to industry recommendations and most codes and regulations.

Most building fires begin with the ignition of decorative materials or furnishings. After the fire has started and gained some strength, the interior finish can become involved and contribute extensively to spread of the fire. Interior finish plays an important role in the occurrence of flashover (see Chapter 3).

The importance of interior finishes to the fire safety of a building has led to development of a variety of fire tests for such materials (see Chapter 5) and study of the correlation of such tests with actual fire situations.

The properties of interior finishes that contribute to fire problems include their ability to spread fire, contribute fuel to the fire, and develop smoke and toxic gases in a fire situation.

Surface finishes have to be considered in conjunction with the substrate material to which they are applied. Thus, a thin combustible finish applied to a non-combustible substrate may present little hazard but the same finish on a combustible backing can present a much greater hazard. Also, adhesives, used to apply finishes, may play an important role in a fire. Adhesives that soften at a moderate temperature can allow wall or ceiling finishes to drop or peel. This effectively increases the exposed area or exposes the substrate, which if combustible, adds fuel to the fire.

The substrate or lack of substrate can change the response of finishes to fires. For example, thin plywood, directly attached to metal or wood studs, as generally used in mobile homes, will ignite much more easily and spread flame much more rapidly than the same material applied over gypsum board, since flame spread on the backside is suppressed by oxygen deficiency and the cooling effect of the substrate. In general, dense, thermally conductive substrates will act as heat sinks and make the finish more difficult to burn. In contrast, insulative substrates will increase the ease of burning of the finish.

If a substantial area of the interior surface of a room is covered with non-combustible lightweight insulation, the spread of fire is more rapid than in a room with surfaces of brick, plaster or gypsum board. Less heat is absorbed by the lightweight material and more is radiated back to increase the fire spread. In room tests with exactly the same furnishings and arrangements, a room with sprayed asbestos wall-finish took less time to flashover than a room with a combustible finish of two coats of oil paint on hardboard (Avon BRENews, 1976).

In some homes and commercial buildings, the decorator has carried the carpeting part way up the walls. From a fire safety viewpoint, this is poor practice as carpeting in this orientation burns much more rapidly than on a floor. It would compare in fire spread potential to curtains and draperies.

#### 4.3.2.5 Floors

The most common form of residential floor construction (in both wood frame and ordinary construction buildings) consists of wood joists supporting a subfloor of wood, plywood or particle board. (Huntington, W. C., 1963). A layer of building paper (polyethylene or other material) is placed above the subfloor. A finish floor layer is laid on the sheet material. This type of construction is most commonly used in wood frame construction and may be used in buildings with steel frames. Flooring constructed in this manner is quite combustible. If protected on the underside, i.e., in the ceiling of the floor below by plaster or gypsum board, resistance to fire is increased. A wearing surface of wood, asphalt or vinyl tile, carpeting or any of a number of other floor coverings is applied to the finish floor layer.

Floor construction in larger residential and other buildings may consist of reinforced concrete slab, light steel joists supporting thin concrete or reinforced gypsum slab, or, less frequently, of light gage sheet steel cellular panels. A wooden finish floor may be laid on top of the concrete or steel subfloor and a suspended ceiling of metal lath and plaster serves as the ceiling of the floor below and provides fire resistance.

Mobile home floors consist of the steel frame or carriage on top of which wood joists are laid. These joists support a particle board subfloor. A layer of thermal insulation is installed below the particle board. The finish floor of both larger residential buildings and mobile homes is covered with a wearing surface of wood, resilient rollgoods, resilient tile or carpet.

Basement floor and the first floors of buildings may be laid on a concrete slab. A layer of plastic film between the concrete and the aggregate base of the house serves as a liquid and vapor barrier. A coating of bituminous material or portland cement containing a water repellent is used between the concrete base slab and the concrete floor in the case of living space. Additional rigid waterproof insulation is provided at the edges of this type of floor to prevent condensation in residences constructed in cold areas. Resilient tile or wall-to-wall carpeting is commonly used as the wearing layer on a concrete slab (Figure 4.1).

A number of polymeric materials other than wood are used in floor construction (Skeist 1966, Davies 1965). The plastic used in largest volume in the covering of floors is poly(vinyl chloride). This is used as the wear surface of resilient flooring and is the flooring material of choice in kitchens and bathrooms, as well as being utilized on other floors of the house. Vinyl resilient flooring has found widespread acceptance because of its resistance to wear and ease of cleaning, as well as its poor flammability. Vinyl resilient floor covering is fabricated in various types of construction:

## MATERIALS

$$H_e = F P (t - t_o)$$

$t - t_o$  indoor temperature less outdoor temperature in °F  
 $P$  perimeter of floor slab in feet  
 $F$  edge loss factor (See details below.)

### Edge Insulation or Perimeter Heating ( $F = 0.55$ )

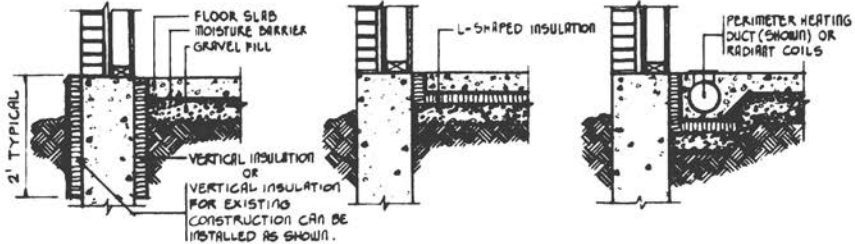

Note: To prevent cold floors always provide insulated slab edges. Typical width of 2 in. thick moisture resistant insulation is 2 ft below the outside grade line (or to 1 ft under the floor slab).

### No Edge Insulation ( $F = 0.81$ )

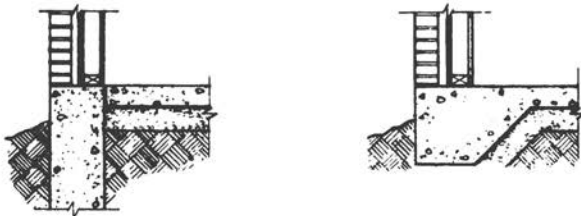

Note: For heat gain analyses, assume no heat gain through floor slab (and below-grade walls) in summer as ground temperature is generally equal to, or less than, room air temperature.

Figure 4.1. Building heat loss/gain-floor slabs.

In winter, the heat loss to the ground through basement floor slabs and walls depends on the temperature of the adjacent earth (or ground water). Estimate this heat loss at about 2 Btuh/sq ft through floor slabs and 4 Btuh/sq ft for basement walls. The heat loss of the floor slab edge, however, is affected by the outdoor air temperature and can be greatly reduced by edge insulation and/or perimeter heating. Floor slab edge heat loss ( $H_e$ ) can be found by the formula shown above.

M. David Egan, CONCEPTS IN THERMAL COMFORT, 1975, p74, Reprinted by Permission of Prentice-Hall, Inc., Englewood Cliffs, NJ.

Vinyl asbestos tile represents approximately half of the floor covering area produced.

Loose-lay rotogravure printed vinyl laminates represent approximately 20 percent of the resilient floor covering area.

The remainder of the vinyl flooring market is divided between:

## BUILDINGS

1. Vinyl yard goods.
2. Foam cushion yard goods.
3. Solid vinyl tile.

### 4.3.2.6 Roofs

*General Construction Details* (Davies 1966, Huntington 1963).

The fundamental purpose of a building's roof is the protection of its contents from the weather and the collection and disposition of precipitation. In addition to design requirements such as weatherproofing, structural integrity and thermal insulation, fire protection must be considered. The building roof should not aid in the spread of a conflagration, either by catching fire from surrounding buildings, by serving as a source of fire for neighboring structures, or by carrying a fire from one part of a building to another part of the same building. The roof structure must be sufficiently strong during fire exposure so that it will not fail prior to the failure of other structural members. The latter type of failure would result in the almost instantaneous spread of fire over the whole structure.

A roof consists of structural or supporting members which carry the weight of other portions of the roof as well as any snow load; the roof deck, that portion of the construction which transmits the roof load to the supporting members; roof covering, the top surface of the roof which is exposed to the weather; thermal insulation; and provision for the drainage of precipitation.

In ordinary one- and two-story residential construction, the structural framework and the roof deck are identical, i.e., the deck supports the weight of the roof. In multistory construction, girders, trusses, rigid frames and the ribs of arches and domes may serve as supporting members distinct from the roof deck. Multistory buildings are usually constructed with a flat roof and the floor construction system is also employed in the roof structure. Sloping roof decks consist of the internal structural framework, i.e., trusses, purlins and rafters and the sheathing which forms the solid top surface. In most residential wood-frame construction, the deck components are wood timbers and plywood. Less frequently, boards are used in the top sheathing. Free-form, shells or vault-shaped roof structures are used infrequently in residential construction.

Roof covering (roofing), is fastened to the top of the deck. This is the weather-proof top covering of the building and may consist of an overlapping mosaic type of construction (e.g., wood, asphalt, or asbestos-cement shingles, or clay or slate tiles) or of layers of sheet material (e.g., flat sheet metal, corrugated metal sheet, overlapping multi-layered, bituminous-saturated roofing felt cemented together with bituminous roofing cement or rolls of roofing felt pre-coated with asphalt). Plastic or asbestos-fiber containing asphalt mastics are sometimes applied as coatings which form an impermeable membrane, as are plastic films which are cemented onto the roof deck.

Insulation and vapor barriers are placed in a roof structure to reduce heat loss

## MATERIALS

and heat gain and to control condensation on interior surfaces. The insulation usually consists of expanded polystyrene beads or board, polyurethane board, glass fiber batts, loose expanded mineral or fire-retarded cellulose (ground newspaper). Layers of low moisture permeability, i.e., water repellent paper, plastic film or aluminum foil serve as vapor barriers.

Gutters and downspouts are used to collect and disperse condensation. These may be constructed of wood, metal (e.g., anodized aluminum) or rigid plastic (e.g., PVC). The intersection of sloping roof with vertical surfaces must be flashed to prevent leakage. Metal, plastic or felt placed in a bituminous matrix are employed for this purpose.

Mobile home roofs are constructed of wood trusses upon which galvanized steel or other metal sheets are laid to serve as both roof deck and roofing.

A relatively new development to roofs for large unobstructed areas is air-supported plastic-coated fabric with or without auxiliary cables. The Pontiac Silverdome Stadium, a recent example of such a roof, is a 10-acre air-supported domed structure using Teflon-coated fiber glass fabric.

A number of polymeric materials are used in roof construction (Maslow 1974, Prane 1966).

### 4.3.2.6.1 Wood in Roofs

Wood is the material used in largest quantity in single and small multifamily residential roof construction. It is found as timbers in the structural members of the roof deck, as boards or plywood sheets in the sheathing of the deck, as wooden shingles and as wooden gutters.

Untreated wood shingles may be readily ignited by small sparks from chimneys or exposure fires, by radiated heat, or by burning brands.

Treatment of wood shingles with fire-retardant coatings has been proposed at various times but has not proved practical because ordinary flame-resistant applications lose effectiveness with continued exposure to the weather. Wood shingles impregnated with a fire retardant are available.

Untreated wood shingle roofs are prohibited by law in the congested sections of practically all large cities.

### 4.3.2.6.2 Asphalt in Roofs

Asphalt, a byproduct of petroleum refining, and, less commonly now, coal tar, obtained as byproduct in coke manufacture, is widely used in roof construction because of its low cost and waterproofing character. The most important use of bituminous roofing material in small residential construction is asphalt used in asphalt shingles. These are made of a heavy rag, paper or wool fiber felt, saturated and coated with asphalt. One surface of the tile contains embedded crushed slate or rock to form a weather-resistant, colored surface. In larger, multistory residences, built up roofing, composed of overlapping layers of asphalt-saturated roofing felt

cemented together with asphalt roofing cement, may be employed. Alternatively, felt, already impregnated and coated with asphalt, is used as roll roofing. Asphalt roof coating containing asbestos fibers is used as a patching material and in flashing and can be obtained in either solvent-based formulations or as a water-based latex.

Roofing felts which comprise the substrate of builtup roofing are normally prepared from graded rags with some admixture of other organic and asbestos fibers. Felts used in asphalt shingles and flashings may be composed of rag, paper, or wool fiber. Paper is used as the outer layer of many glass-fiber insulation batts.

#### 4.3.2.6.3 Plastic Components of Roofs

Plastics used in building roofs are:

Poly(vinyl chloride) — is used in gutters, downspouts and flashings; some plasticized sheet is used as a moisture barrier.

Polyurethane, polyisocyanurate, and polystyrene foams — are used as a core of expanded polymer in panels or foamed-in-place as thermal insulation. These have normally been used over the deck and under the waterproof membrane. The deck must be fire retarded to prevent penetration from a fire under the roof that could ignite the flammable elements of the roof insulation.

Polyethylene — extruded film is used as moisture barrier.

Phenol-formaldehyde resin — is used as a binder in fiberglass thermal insulation and in plywood.

Elastomers (polysulfide, silicone, butyl, Neoprene, Hypalon) — small quantities are used as elastomeric caulking compounds for patching and in flashing.

Some experimental and developmental application of synthetic polymers to roof construction are:

Cellular PVC — used as structural members in roof decks.

Glass Fiber Reinforced Polyester — used in panels in modular constructed homes. The polyester sheet is applied as a sandwich with gypsum board and paper or backed with rigid polyurethane foam.

Plasticized PVC Sheet or Film — used as a membrane and as the top surface of flat residential roofs.

Expanded Polystyrene — used in wood-faced sandwich construction, as panels in modular homes, or spun into domes with a PVC skin.

Elastomers (Neoprene, Hypalon, Silicones, polysulfide) — used as a weather surface on flat roofs (the sheets are glued onto the roof deck). They are also used as a watertight zipper to close joints between foam insulated metal roofing panes.

Poly(vinyl fluoride) — Tedlar coated film applied to asbestos felt sheet impregnated with an elastomeric binder has been used as a weather surface for contoured roofs.

Tapered interlocking foamed polyurethane components are used to give a slope (for drainage), furnish insulation, and be a water barrier in a single system.



## MATERIALS

"Inverted roof" wherein the insulative styrene or urethane foam is put *on top* of the membrane and covered with aggregate. The aggregate holds the foam down, protects the foam from ultraviolet radiation, and protects the foam from fire. This is claimed to have much longer life since the membrane does not have a wide temperature fluctuation such as is experienced when it is on top of foam.

### 4.3.2.7 Insulation

Thermal insulation is used overhead, in the walls and under the floor of many residential buildings and other constructions. The increasing cost of energy has resulted in greater use of insulation in new construction as well as use of additional insulation in older buildings.

Common types of insulation are asphalt-bonded cellulosic fiber, expanded mineral, fiber glass batting, ground waste paper (fire retarded) and synthetic foams (polyurethane, polystyrene and urea-formaldehyde polymer).

Various types of insulative board stock (fiber board, polyurethane and polystyrene) are used under slab floors and around the perimeters between the walls and slab floors. In mobile homes, fiber glass is generally used under the floor.

Wall insulation takes many forms. Fiber board and various polyurethane and polystyrene board stock are used as sheeting over the frame. Some siding has a foamed backing. Foam boards are used inside the frame as a plaster base or over lathe or other covering. Sprayed on polyurethane foam, polyurethane or polystyrene board stock, fiber glass batts, foamed in place ureaformaldehyde foam, or blown in mineral or waste cellulose are used in the cavities within the frame structure. Insulating wall boards of various types are also used as finished walls.

An *exterior* insulation system employing protected foamed polystyrene panels has been developed (Balkowski, Horbach 1968) and employed abroad. In this system, foam panels are adhered to the outside of wood sheathing, block or concrete walls and an exterior plaster coat applied over a reinforcing fabric. Results of large-scale fire tests have been reported to be satisfactory. A U.S. Department of Housing and Urban Development (HUD) Materials Release (#883) has been issued on this system.

Probably the largest, and most effective use of insulation is in the ceilings and roofs of buildings. Most generally used are fiber batts, mineral insulation and some fire-retarded waste paper. In the past, 5–6" of insulation was considered adequate but now 9–12" of insulation is considered better practice. Spray-on foams and gypsum-bonded mineral insulation and various types of board stock are used under roofs and in built-up roof construction (see Section 4.3.2.6). Fiber tiles and boards and foam tiles are also used as insulative finished ceiling.

The fire safety aspects of insulation vary with the material and the details of its application. Obviously, there is no fire hazard in insulations of any kind under a concrete slab. On the other hand, exposed polyurethane or polystyrene foam on the walls has been recognized as a severe hazard and is generally outlawed. In



studies on foam insulation in the walls, fire hazard was not increased if the covering on the foam had adequate fire resistance and there was no penetration. However, it is desirable that new configurations and combinations of materials be tested thoroughly in full-scale tests.

The extensive experience with fiber glass in walls and ceiling has been quite satisfactory. There is, however, a tendency for some resin-backed fiberglass to "punk" or undergo glowing combustion of the phenolic binder. As an example, an electrical short circuit over a ceiling containing fiber glass could start such punking and cause a slow spread of an undetected fire. Additives are used in some industrial fiberglass insulation to prevent this.

Ground waste paper (generally newsprint) is a low cost source of an insulative material and is becoming more widely used. The capital requirements for making this type of insulation are low as are the cost of raw materials and labor. This, together with ecological benefits, is prompting the entry of a large number of small manufacturers into the market. This material, when properly formulated and applied, is quite fire resistant at least initially. However, there have been a significant number of fires that were attributable to this type of insulation. Ignition generally resulted from malfunction of electrical systems (Jones 1977). From two years of tests on cellulose insulation by the Oregon Fire Marshal's Office, it was concluded that (1) there is much difficulty in maintaining quality control during production of this product and (2) under most climatic conditions, there is definite "leaching" of the fire retardant material (Jacobs 1976).

Urea-formaldehyde foam has shown good fire resistance in wall structure and has, in some cases, given significant protection against a fire that penetrated one side of the wall. Its use as exposed foam in an attic should also be relatively safe. However, certain test results (Rossiter 1977) indicate two problem areas with foams based on urea-formaldehyde resin. These are (a) shrinkage and (b) disintegration after exposure to elevated temperature and humidity (e.g., after 14 weeks at 40°C and 92 percent relative humidity, three samples of four disintegrated).

Probably one of the greatest fire hazards from insulation is apt to arise from the "do-it-yourself" or the "quick-fix" by a commercial, industrial or other occupant in their attempt to conserve energy and increase comfort. For example, many home owners and others apply foamed boards to basement and other walls with no fire protective covering. One municipality boasted of covering the inside of most of their large windows in the municipal building with polystyrene foam boards. As the energy crisis intensifies, such hazardous practices will probably increase. (See appropriate recommendations in Section 4.3.4).

### 4.3.2.8 Ceilings

Hot gases rise in a fire; the temperature at the ceiling of a room is much higher than it is even a foot or two below the ceiling. The ceiling material is obviously an important aspect of fire safety in a room.

## MATERIALS

Finished ceilings of most older residential housing are plaster or paint over gypsum lath or board. Also, many ceilings have some type of acoustical tile glued onto gypsum board. Such tile can be mineral, cellulose fiber-based or plastic foam. Mineral tile since it does not burn, offers good resistance to fire; but, as indicated for insulative wall finishes, would return more heat to the room than denser ceilings such as plaster. The same applies to fibrous tile. In addition, fibrous tile, although treated to reduce flaming combustion, can smolder and slowly spread fire across the ceiling. Many fires, thought to have been extinguished, have reappeared due to smoldering in the ceiling tile. Foamed thermoplastic tile usually softens and collapses or falls off the ceiling before it ignites. Thus, it does not insulate the ceiling and return heat to the room. However, if such tile is painted or otherwise treated so it does not readily melt the drip or fall, it can become a means for rapid propagation of flame across the ceiling.

A common type of ceiling is one that is suspended from ceiling joists by metal hangers. The ceiling material can comprise metal panels (with or without holes and with or without an insulative backing), fibrous composites or plastic panels. The latter are used when fluorescent lighting is installed behind the ceiling. The plastics used are glass-reinforced polyester, styrenic polymers, acrylics, and unplasticized polyvinyl chloride. Of these, polyvinyl chloride is the most fire resistant. The thermoplastic acrylics and styrenes tend to fall from the hanger, rather than spread fire across the ceiling. The fallen panels can burn on the floor but this is less a hazard than on the ceiling. The glass-reinforced polyester is more likely to stay in place and burn.

### 4.3.2.9 Doors

Doors play an important role in the spread of many fires. The materials used for doors and types of construction vary widely. Wood is the most common and is found in panel, solid core, hollow core, foam core, mineral core and chipboard doors. Dense wooden door structures such as solid core and mineral core are obviously the most resistant to burn through, other things being equal. Metal doors with or without mineral cores are used for even greater fire resistance.

Recently doors of molded structural foam that simulate the texture and appearance of wood have become available. These doors should be carefully appraised for their impact on fire safety. This should be done from the viewpoint of control of fire spread from one area to another as well as the contribution to fire load and tendency to flash over.

### 4.3.2.10 Trim

Interior trim has generally been wood but increasing use is being made of extruded rigid structural foam. This is appearing in cover molding, base molding, door and window trim and various other decorative applications.

Much of this trim is rigid unplasticized high density polyvinyl chloride foam that contributes little to flammability or flame spread.

Simulated wood beams made of molded polyurethane foam are used for decoration. Fire hazard depends on the extent and location of their use and how the area is used. As with other exposed combustible foams, extensive use in public buildings seems inadvisable.

### 4.3.2.11 Skylights and Glazing

There are three polymeric materials in common use for skylights and glazing: acrylic, polycarbonate and fiber glass-reinforced polyester. Acrylic is the most used; it has good clarity and light transmission. Although easily scratched, it is tough enough to withstand substantial impact. Due to ease of forming and some flexibility, acrylics are often used in shaped sections. Standard round domes are readily available up to 10 feet in diameter and rectangular domes up to 10 feet by 12 feet.

Polycarbonate is also completely clear and is considerably tougher. It is preferred where vandalism is a problem; particularly for flat sheet applications such as in regular windows. (However, it should be noted that a glowing cigarette can melt a hole through a polycarbonate pane).

Fiberglass-reinforced plastic (FRP) skylights offer the ultimate in toughness. Clarity of course, is much less than in the previous two materials but actual light transmission is very high, from 75 to 85 percent according to whether the skylight is single or double skin. Because of their toughness and lower thermal expansion, FRP skylights are able to be made self flashing. This offers considerable economies of installation (Monaghan 1975).

Increased use of plastic glazing is projected due to improved products with special coatings that greatly increase the scratch resistance of acrylic and polycarbonate glazing. Also, some localities are legislating safety storm doors and there is increasing use in areas of high vandalism.

The higher costs of energy and increasing needs for storm glazing is increasing the use of various films and sheets (polyethylene, polyvinyl chloride, polystyrene and acrylics) for temporary and permanent use. The fire hazard from use of such materials as a barrier *inside* the regular glazing could be comparable to that from draperies of the same chemical composition. A major fire threat comes from the possible propagation of fire from a lower floor to a higher floor by combustion of exterior plastic glazing.

### 4.3.3 Utilities and Services

#### Introduction

This section includes discussion of the uses of polymer materials in the electrical, ducting, piping, plumbing and lighting systems of buildings. These applications are important from a fire safety viewpoint due to nearby potential ignition sources and the rapid replacement of metal and ceramics in piping and plumbing systems by plastics.

#### 4.3.3.1 Electrical Conductor Insulation

Since about 1938, PVC has been used in almost all residential installations as the primary electrical conductor insulation. Prior to this date, insulation consisted of a rubber compound covered with an asphalt-impregnated cotton braid. Flame-retardant waxes were used in some instances. In commercial buildings such as hospitals, offices, high rise and multiple dwellings, etc., PVC is also used in more than ninety percent of the installations. PVC insulation is required to pass a vertical flame test (UL83, Para. 74), FR-1 not being required (see Table 5.2-1, Chapter 5).

For service rated above 600 volts, PVC is not generally used; rubber-neoprene or crosslinked polyolefin insulation is used.

Crosslinked polyolefin insulation is employed in about five percent of buildings because flammability codes or design engineers specify these products to improve protection against overloads, high temperature ambients, or voltage surges. The crosslinked polyolefins are required to pass a horizontal flame test (UL44, Para. 3.0) (see Chapter 5).

Large industrial complexes and utilities use crosslinked polyolefin insulation in armored cables exclusively for power distribution circuits. The armored cable provides improved crush resistance. In those instances where high reliability, high ambient temperature, and high current density are design parameters, higher cost materials can be justified. Passage of a horizontal test (UL44, Para. 3.0) is required but passage of a vertical test FR-1 (UL44, Para. 74) is optional. Non-armored neoprene-hypalon jackets are used for control circuits. PVC is used in about 75 percent of the instances (UL83, Para. 74). Crosslinked polymers (UL44, Para. 74) are installed where higher reliability is required.

Silicone insulation is found in areas like steel mills where conductor temperatures above 90°C are found. Also, in rewiring old buildings where space is limited, silicone rubber is used to justify a higher conductor operating temperature. This insulation is required to pass a horizontal flame test (UL44, Para. 3.0) and in some instances a vertical flame test, FR-1, (UL44, Para. 74).

In electric generating stations, the insulation must pass a vertical flame test FR-1 (UL44, Para. 74) and the IEEE 383 Vertical Tray test. Ethylene Propylene Copolymer (EPM) or crosslinked polyolefins with Hypalon or Neoprene jackets are used in fossil fuel electric generating stations. EPM or crosslinked polyolefins containing halogenated additives with Hypalon or Neoprene jackets are used in nuclear installations. Thermoplastic fluoro-olefin polymers are beginning to find increased use in nuclear power plants.

#### Grouped Cables

Cables are frequently grouped in trays, conduits, etc., in large industrial plants, hospitals, commercial establishments, electric generating stations, etc., and are often almost inaccessible. A fire under these circumstances can lead to loss of power, dense smoke, and destruction of considerable cable. Yet, many of the

## BUILDINGS

standard flammability tests are performed on single insulated conductors.

Two relatively recent fires, i.e., the World Trade Center (Lathrop-1975a) and Telephone Exchange (Lathrop 1975b) fires in 1975, emphasize the special hazard of vertical and grouped cableways. In the case of the World Trade Center, the fire reportedly began in a file room that contained open shelf files. Opening onto the file room was a telephone closet with a metal door that contained louvers. Inside the closet, plywood boards had been mounted on the walls; telephone terminal boards were attached to the plywood. In the floor slabs above and below the telephone closets on each floor was a hole approximately 12 inches by 18 inches through which six large cables ran. This series of telephone closets terminated on the forty-first floor. No firestopping was provided.

The fire spread not only within the office suite on the eleventh floor where it originated but also into the telephone closet, where it ignited the plywood, plastic terminal strips and PVC insulated wire. Once the large PVC insulated cables were ignited, there was nothing to stop the fire from spreading. The fire spread downward to the tenth floor, where it burned out the telephone closet on that floor and did some damage to the area near the closet. The fire burned upward as high as the sixteenth floor, and created minor damage outside the closet on the twelfth floor. Fire Department actions prevented the spreading fire from producing more extensive damage.

The Telephone Exchange fire apparently originated in a basement cable vault. The fire extended to the first floor through the slot provided to feed cables to the main distribution frame. It then traveled to the second floor by way of cables in the vertical cable racks. The cables in the vault had three types of sheathing — lead, polyethylene over metal, and PVC over metal. There was paper pulp or PVC insulation on the conductors. The cables on the first and second floors were mainly older cables and had various types of insulation. There was, however, a considerable amount of sheathed PVC cable with PVC insulation on the conductor.

After the cables extended through the slot, asbestos-cement cover plates were fitted over the remaining openings. Cables to upper floors were run through a terra-cotta block wall located against an exterior wall. Smaller cables ran between floors by way of vertical cable racks. The small openings between floors were protected by flame retardant treated cotton bags. The bags were filled with mineral wool. They were somewhat effective in retarding the spread of fire. There was no sprinkler protection in the area of the fire. Ionization-type smoke detectors were provided in the power room and main frame room on the first floor. As in the World Trade Center fire, the vertical spread of fire was by way of cable insulation.

The practice of grouping cables presents a serious fire hazard. The conditions for flame propagation are very different when cables with flame retardant insulation or covering are grouped in large numbers. Some safeguards (Hedlund — 1976) include installation of automatic sprinklers, smoke detectors, use of improved flameproof coverings and an automatic carbon dioxide flooding system.

A recent National Academy of Science Workshop, *Workshop on Flammability, Smoke, Toxicity, and Corrosive Gases of Electrical Cable Materials* (1977), has reviewed this subject in some detail. A report (NMAB-342) containing the talks and Conclusions and Recommendations will be published by NMAB in the near future.

### 4.3.3.2 Ducting

Ducting comprises heating ducts, air conditioning ducts, vents for driers, industrial fume and ventilation ducts, and multi-purpose flexible ducts. The plastics generally used are glass-reinforced polyesters, glass-reinforced epoxies, various olefin polymers, rigid and flexible polyvinyl chloride, and neoprene. Advantages of plastic ducting over metal ducting lie in greater corrosion resistance and easier application.

Fire safety aspects center primarily on industrial and specialized uses. Consideration has to be given both to propagation of fire within a duct where ample air is available and to propagation by combustion of the external surface of the ducts. The flammability test most generally used for ducting is the Factory Mutual Approval Standard #4922.

### 4.3.3.3 Piping

Piping technology has advanced considerably since the start of the thermoplastic pipe industry in the United States in 1948. There has been a gradual improvement in impact strength, durability and material uniformity through quality control and introduction of product standards. Improvements in these areas and development of design specifications for particular applications have led to an increasing acceptance by designers, contractors, and building code officials. The standards and other information on thermoplastic piping in residential plumbing was reviewed recently (Wyly 1975).

Thermoplastic piping has different characteristics from piping made from the traditional metals. Some of these characteristics yield advantages, but others lead to difficulties under some conditions. Characteristics not related to fire safety will not be covered here.

Thermoplastic materials are used in building construction for water service and water distribution piping; for drain, waste and vent (DWV) piping; for electrical conduit; and for gas service. Although over 25 different plastics have been used in various pipe applications, only four are now widely used for residential plumbing: (1) acrylonitrile-butadiene-styrene (ABS) and (2) Poly(vinyl chloride) (PVC), both used where plastics are approved for DWV systems (PVC to a lesser extent than ABS) (3) chlorinated polyvinyl chloride (CPVC) recently introduced for use in hot and cold water distribution systems, and (4) polyethylene (PE) for underground and water service piping.

Two significant concerns arise from the use of thermoplastic piping for plumbing. These relate to the potential for (a) fire spread and (b) spread of smoke and toxic gas in a burning building.



ASTM D635 has been used to determine relative burning characteristics of plastic materials expressed in the terms "time of burning" and "extent of burning." This test, while appropriate for comparing the relative burning characteristics of bar specimens under stated test conditions, does not provide an evaluation of the fire performance of a plumbing system, as affected by the many and varying parameters of construction introduced in building system design and installation. ASTM Standard D635 is not intended to be a criterion for fire hazard.

When thermoplastic pipe burns — (a) it releases relatively large quantities of smoke and gases; (b) it provides heat for increasing the intensity of the fire; (c) it may provide a path for flame spread along its surfaces; and (d) it may leave open holes at wall or ceiling penetrations; during the fire these holes could provide a route for the passage of hot flame and gases between rooms. These events must be considered when evaluating the fire risk associated with the use of thermoplastic pipe and pipe fittings in the water distribution and DWV systems in buildings. Attention has been directed toward the design of installations which would minimize the risks outlined above. This work has been recently reviewed (Wyly 1975). For example, in full scale fire tests on thermoplastic piping at NBS (Parker 1973), fire endurance tests were performed on wall and plumbing chases containing ABS, PVC, and metallic DWV systems. In each case there were back-to-back laterals connected to the stack through a double reducing sanitary tee. One lateral passed through the surface of the wall exposed to the test furnace while the other lateral penetrated the opposite wall surface. Both laterals (simulating sink drains) were terminated by water-filled traps as under normal service conditions. Thus a direct path was provided for the fire to progress through the wall or chase.

It was found that the fire endurance of a plumbing chase containing a 4-inch ABS stack with 3-inch ABS laterals was reduced to a value significantly less than the fire rating of the chase, whereas in a chase with a 4-inch PVC stack with 1½-inch laterals the fire endurance was judged not significantly less than the chase rating. Tests showed that the situation with the ABS could be corrected by connecting the laterals to the stack by means of a wye so that they penetrated the chase wall at a downward angle of 45 degrees and were enclosed in steel sleeves extending downward from the point of penetration. This illustrates the importance of good design practice when employing polymeric materials in new situations.

The endurance of a one-hour fire rated 2 X 4-wood-stud-and-gypsum-board wall was less than one hour with both ABS and PVC DWV systems using a 2-inch stack and 1½-inch laterals. However, when the depth of the wall was increased by using 2 X 6 wood studs, both ABS and PVC systems passed the one-hour test successfully. But this success was contingent upon adequate sealing of the holes through which the laterals penetrated. It was also found very important that the lateral hubs of the stack-to-lateral junction fitting not penetrate through the surface of the wall.

An undesirable effect of smoke is to reduce the visibility thereby obscuring

## MATERIALS

escape routes and making it difficult for firemen to locate the fire. Although it is unlikely that the smoke contributed by thermoplastic pipe in a chase or wall cavity would be comparable to the smoke produced elsewhere in the room of fire origin, the smoke in a chase could find its way to other parts of the building.

The amount of thermoplastic pipe used in the plumbing system is usually small compared to the amount of thermoplastic and other combustible materials used in the furnishings and structure of a building. Furthermore, the pipe is less likely to be ignited because of its location and function.

However, concern continues to be expressed that thermoplastic pipe and fittings in a building fire situation may contribute to the loss of life and property. Such fire hazard may be reduced to an acceptable level by the use of proper design considerations and installation procedures.

### 4.3.3.4 Plumbing Fixtures

Plastics are rapidly taking over the quality sanitaryware field (Wood 1975). Major applications are: acrylic and polyester in simulated marble for bathroom fixtures and vanity tops with integral bowls; polyester-glass and combinations of polyester-glass and acrylics for tub and shower units; and ABS for toilet tanks, toilet components, shower heads, faucets, etc. Other resins, e.g., acetals, Noryl, nylon, polycarbonate, polyolefins, and poly(vinylchloride) are beginning to be used in small quantities in various applications (Table 4.5).

*Table 4.5. Consumption of Plastics in Bathroom Applications (Wood 1975)*

---

	1000 metric tons)	
	1975	1980 (est.)
Polyester	90	180
Acrylic	10	40
ABS	26	50
Other	4	8

---

The question of fire safety in such uses of plastics has received attention and studies are continuing. The greatest potential hazards are with the tub and shower units due to the vertical surfaces and large areas. Significant improvements have been made in reducing the hazard from such units. Bowls, vanity tops and small plumbing parts offer less hazard. The Department of Housing and Urban Development has proposed interior standards for tub and shower units that set flame spread and smoke limits. Considerable efforts are under way both on the testing and improvements in fire safety of such components. Such work needs to continue with due consideration being given to the total system (flooring, walls, etc.).



#### 4.3.3.5 Lighting

The polymeric materials generally used for lighting fixtures, diffusers, lighting panels, globes, etc., are polymethyl methacrylate, polystyrene, rigid polyvinyl chloride, polycarbonate and some polyolefins. Acrylic polymers and polycarbonates are displacing polystyrene in most fluorescent light diffusion systems and lighting panels because of improved light stability. Poly (vinyl chloride), originally widely used for light diffusion panels has better fire resistance but poorer color stability than the acrylics. Polycarbonate, because of its toughness, is used for outdoor light globes in areas of high breakage potential.

A critical fire safety analysis should be made where large areas of panels or diffusers are used. Where vertical panels are used, the flammability of adjacent materials and potential for propagation should be considered. Lighting panels are generally used on the ceiling; thermoplastic polymer panels often soften and fall to the floor rather than burning in place on the ceiling.

#### 4.3.4 Conclusions and Recommendations

##### Construction

###### *Conclusions:*

- The fire safety aspects of the various classes of conventional building construction are generally known and good practices are well documented in various codes.
- New approaches to construction, e.g., air-supported structures, are continually being proposed; fire safety is not usually given high priority in judging the acceptability of the concept.

###### *Recommendations:*

- Evaluate more thoroughly the fire safety of the various types of air-supported structures.
- Require fire safety analysis and large scale testing on new building concepts before approval of occupancy.

##### Building Elements

###### *Conclusions:*

- The use of large areas of flammable materials on outside walls (curtain walls, glazing, etc.) can lead to propagation of fire from floor to floor.
- Thin unbacked plywood and flammable plastic wall coverings and partitions can be very significant fire hazards.
- Most critical elements of construction are generally controlled by codes and standards with varying degrees of success.
- Ground or shredded waste newsprint for insulation is economically and ecologically very attractive. However, poor quality control and lack of permanency of the fire retardance of some systems introduces a potentially severe fire hazard.

## MATERIALS

- The "energy crisis" has fostered a number of do-it-yourself energy conservation measures. Many of these create potential hazards (e.g., interior plastic storm glazing, foam sheets over windows and interior walls, etc.).

### *Recommendations:*

- Require proof of acceptable safety of systems that use large areas of flammable polymeric materials on outside walls or for glazing.
- Through full scale testing, define more accurately the relative hazards of the various types of interior wall coverings that employ polymeric materials, including plywood.
- Recognize and assess the problems in current waste paper insulation systems so that the situation may be remedied or the use banned as may be indicated.
- If indicated, initiate a government-funded program to develop a low cost, effective, reliable, permanent fire retardant treatment for utilization in insulative waste paper.
- Educate the public (such as by point of sale warnings) as to the hazards of certain "do-it-yourself" insulation systems.

## Utilities and Services

### *Conclusions:*

- The use of plastic piping offers numerous advantages in material and installation costs; but, such use can add to the fire hazard in buildings.
- The fire hazard from use of plastic pipe can be reduced to an acceptable level by proper design considerations and installation procedures.
- Plastic plumbing fixtures offer certain advantages over ceramic and metal fixtures but introduce a significant fire hazard. The public and some builders are not generally aware of the hazard.
- There are considerable variations in the ease of ignition and rate of fire propagation in the various materials used for plastic plumbing fixtures.
- Large areas of lighting panels or diffusers can be significant hazards.
- Electrical conductor insulation in grouped cable installation can pose a considerable fire hazard.

### *Recommendations:*

- Where necessary, revise building codes to allow use of plastic piping when installed in accordance with defined safe practices.
- Continue studies on the testing and improvement of plastic plumbing fixtures.
- Require prominent, factual statements on labels and in commercial literature on the fire hazards of plastic fixtures.
- Where large areas of lighting panel and diffusers are used in public buildings, require a critical fire safety analysis and appropriate action.
- Develop improved fire stopping and fire protection systems for grouped cable installation, particularly in vertical chases.

#### **4.4 Residential Occupancies**

This section is concerned with the types of structures used for residential occupancies, the contents associated therewith and the contribution of polymeric materials to the fire safety thereof. Emphasis is placed on residential occupancies since about 90 percent of all building fire deaths occur in residences (Section 3.2). Particularly, the contents of residential occupancies will be covered in some detail since the contents play such an important role in the fire safety of residences.

Included in this section are single-family and multi-family low-rise and high-rise residences. Other types of occupancies are discussed in Section 4.5 ff.

##### **4.4.1 Structures**

The majority of single family and small multi-family houses and apartments are of "wood frame construction" (Section 4.3.1.5) with some being "ordinary construction" (Section 4.3.1.4). Larger apartments and condominiums and high-rise apartments are of fire resistive construction (4.3.1.1) or non-combustible/limited combustible construction (Section 4.3.1.2).

Building elements used in housing are covered in the general section on building structure; most of these appear to greater or less extents in residential building.

The fire safety aspects of building elements for residential housing are covered by many codes and standards (HUD, NFPA, Local and State Codes). However, it should be remembered that there are many residences, that for one reason or another, do not conform to the level of safety prescribed by these documents.

The most frequently used polymeric material in the structure of residential buildings is wood. The fire safety aspects of this material are well known and will not be elaborated upon here. Synthetic polymeric materials are employed as exteriors (e.g., vinyl siding), plywood adhesives, curtain walls (proposed in some high rise buildings), window frames, thermal insulation, glazing, electrical insulation, piping, plumbing fixtures, lighting panels, trim and interior finish. The interior finish is one of the main construction elements that determine the fire hazard of a residence.

##### **4.4.2 Contents**

###### **4.4.2.1 Furniture**

Plastics in furniture construction have been reviewed (Breitenbach 1974) and a materials survey of the furniture industry was conducted by the Bureau of Standards (Schmulling 1974). The amount of wood used in furniture construction was estimated to be about 15 billion pounds, plastics 1 billion pounds, cotton 500 million pounds, and rayon, jute, paper, cardboard about 300 million pounds. The furniture industry is fragmented, having about 3600 manufactureres. The smaller manufacturers tend to be makers of upholstered furniture.

#### 4.4.2.1.1 Furniture Types and Construction

##### Upholstered Furniture

Upholstered furniture can be defined as a unit of the interior furnishings. It is filled with a resilient padding or filling, covered wholly or in part with a fabric, and designed, intended and promoted for seating. The predicted average life of a piece of upholstered furniture varies from 5 to 14 years. This means that a large portion of the furniture manufactured over the past 10 years is still in service and that the furniture being manufactured now will be in service for many years to come.

The typical upholstered piece of furniture of current manufacture will have a wood frame, polyurethane cushion, cotton and polyurethane in the arms, backs and decks, and a choice of many cover fabrics. The future trends in frames show wood being replaced by steel or plastics, such as polystyrene, polyolefins, ABS, and polyurethane. In cover fabrics the traditional cotton and rayon are slowly being replaced by nylon, polypropylene, and polyvinyl chloride.

*Frames* — Approximately 95 percent of the frames used in upholstered furniture are made of wood that is basically solid; but, up to 15 percent of the wood might be plywood or particle board. The remaining 5 percent of the frame material would include steel, polystyrene, polyolefins; ABS, and rigid polyurethane foam as load bearing parts. Rigid foamed polyurethane, polystyrene, and filled polyester appear as small trim parts. Increasing use of plastic in frames appears to be a future trend in the furniture industry. An economic advantage exists in molding an entire side of a frame especially where arms are not upholstered, or even the complete frame in a single molding operation.

*Cushioning, Back, Arm, and Deck Construction* — The bulk of the material used are flexible foamed polyurethane and cotton batting. (255 million pounds of polyurethane and 165 million pounds of cotton were used in 1972). It should be noted that to fill a given space takes about 3 to 4 times the weight of cotton as polyurethane. In addition, about 20 million pounds of polyester batting are used to cover polyurethane cushions and for other padding applications.

To gain perspective, it is necessary to discuss types of construction. The typical upholstered piece will have loose cushions that are about 90 percent polymeric, upholstered arms that are 86 percent polymeric, and an upholstered back that is 63.3 percent polymeric. Loose cushion seats are about 95 percent flexible polyurethane foam with about 70 percent of this foam being wrapped with ½ to 1 inch of polyester batting. In upholstered arms the padding composition is about two-thirds cotton and one-third polyurethane with a small amount being cotton-over-polyurethane. Upholstered backs use about half cotton and half polyurethane; but, this combination of materials is about a third of the total upholstered backs. Cushion backs, are mostly of cotton and polyurethane, shredded polyurethane, and slab polyurethane foam. Up to now little flame retarded materials have been used in any of these cushioning materials.

## BUILDINGS

*Cover Fabrics* — This is the most varied area of upholstered furniture. About 80 percent of the cover fabrics are wovens and the rest are coated or laminated fabrics. The materials used in face fabric in 1972 are listed in Table 4.6.

Table 4.6. Face Fabric Consumption in 1972

Material	Percentage	Fabric Type
Rayon	29	woven
Cotton	22	woven
PVC	20	coated or laminated
Nylon	13	woven
Olefins	9	woven
Acetate	4	woven
Polyurethane	2	coated or laminated
Other	1	woven

A significant trend in woven fabrics is a decrease in cellulosic materials utilization between 1968 and 1973 and a corresponding increase in use of polyolefin fabrics. Woven fiber utilization is complex in that more than one half of the face fibers are blends. At least 75 percent of the woven fabrics are backed with latex rubber (mostly styrene-butadiene rubber). If a typical cover fabric had to be chosen, it would be a velvet composed of cotton and rayon fibers. But to represent 85 percent of the market would require including vinyl, olefin, nylon, and blends of these fibers.

Until recently little consideration was given to fire retardancy. Only in the case of contract work, sales to agencies such as the Port Authority of New York and New Jersey, or others with special requirements, has it been considered. In order to meet the vertical burning tests, most upholstery fabrics require a flame retardant backing plus an impregnation of the fiber. These treatments can affect hygroscopicity adversely, increase hand, (make cloth stiffer) change color, increase powdering, reduce tear and tensile strength, change dimensions, and increase corrosivity.

*Fabric in Dust, Spring, and Deck Covers* — The dust cover (cambric) is generally cotton or non-woven polyolefin cloth. The spring cover is still mostly jute but woven polypropylene is now coming into wider use. The deck cover is mostly cotton denim but non-woven polyolefins are starting to be used as a replacement.

### Case Goods

Case goods are mainly dining room and bedroom furniture, desks, bookcases, headboards, etc. They have traditionally been made from wood. The average life for case goods is considerably longer than for upholstered furniture; therefore, current production will last for a long time; it is mostly wood.

## MATERIALS

In 1972, of the materials used in the manufacture of case goods about 85 percent were wood, 14 percent were plastic and 1 percent were steel. The trend of plastics replacing wood has continued. The wood is used as 30 percent solid for framing, dividers, and drawers; 60 percent particle board for cores, veneers, and laminating; and 10 percent fiber and hardboard for paneling, dust partitions, casebacks, and drawer bottoms. About 5 percent of the case goods are finished with a vinyl overlay. The use of melamine laminate tops on case goods is substantial. The 14 percent plastic materials in case goods comprises about 55 percent polystyrene, 25 percent rigid polyurethane foam, and 20 percent polyester (thermoset). Plastics are predominantly used in styles such as Mediterranean and Traditional, but can also appear as ornate pieces for legs, headboards for beds, mirror frames, and small raised decorative designs in other styles. Lower fabrication costs are the incentive.

Polystyrene is molded primarily as a solid piece; but up to 10 percent probably is structural molded foam. It is used where there is sufficient volume to justify making expensive injection-molding molds. Polystyrene is usually finished to simulate wood; however, if not properly done, it has a higher sheen than the wood. With a proper prime coat, it finishes like wood and is not easily distinguished from wood.

Rigid foamed polyurethane is used in detailed drawer fronts, door fronts, headboards, and mirror frames. It is the least expensive way of making ornate pieces if volume is not high enough to justify an injection mold. It is much easier to finish like wood than polystyrene and it feels like wood. The polyurethane used in non-loadbearing decorative applications has a density of 18 lbs/cu ft or less; for mirrors and other loadbearing structures it has a density of about 24 lbs/cu ft.

Polyester filled with about 15 percent pecan or walnut flour is used in up to 10 percent of table and dresser edges, small raised decorative designs, some ornate table and chair legs, and in making ornate prototype furniture for introductory shows.

### Occasional Furniture

Here are included shelving, desks, bookcases, room dividers, and parsons tables, coffee tables, and end tables. The type of construction and materials used for occasional furniture follows closely that for case goods. The only trend observed seems to be a slightly greater inroad of plastics and, possibly, a measurable amount of metal replacing wood.

The inclusion of patio and recreation room furniture into this classification increases the plastics use to about 30 percent, including contemporary-styled lounge chairs, loveseats, parsons tables, end tables, etc. Polystyrene is the predominant used resin, but smaller volumes of polypropylene, ABS, acrylic, and polyvinyl chloride are also used.

### Kitchen Furniture

*Chairs and Tables* — Kitchen chairs and tables have rigid frames made mostly from steel with some plastic and wood. The surface areas are plastic and

composition board. The glass-filled reinforced plastics predominate, but ABS, acrylic, polypropylene, and some impact polystyrene can be found, especially in the chairs. A few of the tables have glass tops but most tops are composition board covered with melamine laminate. The padding and cushioning are a relatively small portion of the chairs; they do not fall into the definition of upholstered furniture. The padding is about 75 percent foamed flexible polyurethane, 20 percent cotton, and 5 percent other materials. The cover materials were considered under upholstered fabrics. Plastics use is increasing at the expense of wood and steel.

*Cabinets* — Kitchen cabinets are included with other cabinets. Cabinets are similar to furniture and are made predominantly of wood. (80 percent wood, 5 percent metal, and 15 percent plastics). The market is large. About 40 million cabinets were made in 1973. These figures include bath and mobile home cabinets which would be slightly over 10 percent of the total. The wood portion is about 2/3 plywood and composition board; the rest is solid wood. The plastic used is for finishing; it is mostly a melamine laminate with some vinyl overlay. Polystyrene doors have been introduced into cabinet design; in some cases all-polystyrene cabinets are made.

The use of rapidly combustible doors or cabinets in the kitchen and especially over a range is an unnecessary fire hazard.

### **Bathroom Furniture**

In vanities, cabinets, and space saver units, the material used is divided into 60 percent wood, 25 percent plastic and 15 percent metal. Plastics used are PVC, ABS, polystyrene, acrylic and laminated thermoset materials. The trend is toward increased use of plastics.

#### **4.4.2.1.2 Fire Safety of Furniture**

Upholstered furniture has been pinpointed as one of the major contributors to fatal fires in residential occupancies and in many cases of commercial occupancies. The U.S. Department of Commerce has published a "Notice of Findings That Flammability Standards for Upholstered Furniture May Be Needed" (Federal Register, Vol. 37, No. 320, Nov. 19, 1972) and the National Bureau of Standards is working on a proposed standard. The California Bureau of Home Furnishings has issued proposed performance standards [Bull. 116, 117 (1964) and Home Furnishing Act, Article 7, Reg. 19161, Sec. 1374] Final California Performance standards issued in 1975 require all filling materials in upholstered furniture to pass open flame and cigarette tests and finished furniture to pass cigarette tests.

Programs on the fire safety of furnishings are underway in a number of laboratories. At the Bureau of Standards, the types of construction and materials used in furnishings that are going into the American home are being evaluated. Work by the Rubber and Plastics Research Association of Great Britain continues on the flammability of cushioning, upholstering, individual items of furniture and large scale



burns of furnished rooms (Taylor 1976). The Flammability Research Laboratory of the California Department of Consumer Affairs continues studies on upholstered furniture (Damont 1976) and a variety of studies on the fire safety aspects of furnishings are conducted at the University of California at Berkeley (Williamson 1976). Much work appears to be conducted by polymer producers, fabricators and others. For example, a filled neoprene sheet has been introduced for use between flexible foam cushioning and the covering fabric. This is said to greatly decrease the ease of ignition of the foam by small ignition sources such as cigarettes (Aron 1976). In this connection the duPont Vonar systems should be noted. (DuPont Magazine, Jan.—Feb. 1978, p. 17 ff.)

The results of these studies show conclusively that there are strong interdependencies between the filling material, the cover fabric, the ignition source and geometry of the system. Since cigarettes have been shown to be a major ignition source for upholstered furniture much attention has been given to this type of ignition. Not surprisingly, however, for many sub-systems (e.g., filling, cover, frame, welt, etc.) there is little correlation between cigarette and flaming ignition. Damant (1976) from his extensive work on components and prototypes of upholstered furniture concluded:

- The use of flame retardant filling in many furniture systems can reduce the incidence of cigarette-induced smoldering combustion, reduce the spread of flaming combustion and retard the progress of any ongoing large scale combustion.
- In many systems the use of flame retardant cotton batting can provide significant increased protection over non-fire retardant batting.
- Overall, polyester battings perform better than cotton in cigarette tests.
- Some flexible polyurethane foams are more likely to sustain smoldering combustion than others.
- The exterior fabric has an important influence on whether or not a cigarette causes ignition in a furniture system.
- Fabrics based on cellulose are the most hazardous in terms of cigarette-induced smoldering combustion.
- Most thermoplastic fabrics perform well in cigarette tests.
- Smoldering combustion of thermoplastic fabric covered system may be induced.
- Vinyl and expanded vinyl fabrics perform well in cigarette tests.
- Flame retardant finishes on cellulosic fabrics are usually not effective in prevention of smoldering combustion.
- The choice of welt cord can be critical. Synthetics perform better than cellulose.
- Tight seat construction has a greater tendency to ignite than loose cushion construction.
- The use of heat sinks with the cover fabric shows tremendous promise.



- There may be limitations in predicting the behavior of furniture that does not correspond to the geometry and orientation of the mock-up systems tested.

Another area of concern is the increased use of structural foam and dense plastic for case goods, occasional furniture and kitchen cabinet fronts. The simulation of the appearance and feel of wood with polymer foams and composites has become so good that it is difficult to detect the simulation. Plastic compositions used in these applications generally increase the fire hazard over the wood they are replacing. This is primarily due to the higher rate of combustion and associated higher rate of heat, gas and smoke production. This has been vividly demonstrated in a test showing the rapid burning of a structural foam baby crib (Williamson 1976). Polymer systems that burn no faster than comparable wood products are possible; the economics may or may not be satisfactory for furniture applications.

As a minimum, the public should be made aware of the flammability of the products it purchases and, as a maximum, "flammability" no greater than that of the previously available counterpart should be defined and required. However, the need for this level of flammability would depend on a number of factors that vary from person to person and use to use. The amounts, locations, occupancies and specific items could have major bearing on whether the use posed a significant fire hazard or not.

#### 4.4.2.2 Floor Coverings

During the past 15 to 20 years, the manufacture and use of carpeting has undergone large changes. The introduction of the tufting method for carpet construction and the development of man-made fibers specifically for carpet applications have made quality carpet available at low cost. The improved aesthetics, acoustical and insulation properties and ease of maintenance account for the appeal.

Carpets consume 15 to 20 percent of total synthetic fiber output in any given year. In the peak year of 1973, 1.7 billion pounds of fibers were used to produce in excess of 1 billion sq. yds. of carpets and rugs (Anderson 1976). Synthetics account for 98.5 percent of the carpet fiber market; nylon is the overwhelming leader with 76 percent of the market, polyester is second, and acrylic is third. Table 4.7 summarizes recent annual consumption by fiber and makes projections ahead to 1980 to show the expected industry growth and shift in fiber preferences. Fiber availability, performance, economics and fire safety regulations account for the observed dramatic shifts in fiber usage.

The face-fiber represents less than half of the materials content of the carpet assembly that includes an underlay or attached cushion. When a carpet is installed by the direct gluedown method, without underlay, the face fiber is the dominant constituent. The essential elements of a tufted carpet/underlay assembly are identified in Figure 4.2.

The *face fiber* may be a single fiber or, quite often, a two-component blend of the fibers cited in Table 4.6.

## MATERIALS

*Table 4.7. Fiber Consumption in Carpeting (Anderson, 1976)*

Millions of lb	Fiber Consumption*							
	1970	1971	1972	1973	1974	1975**	1976**	1980**
<b>SYNTHETIC</b>								
Acrylic	153	158	149	171	129	100	105	150
Nylon bulk continuous filament	320	400	534	602	562	535	620	900
Nylon staple	206	323	479	599	533	515	590	860
Polyester staple	184	190	187	194	142	135	165	275
Polypropylene bulk continuous filament and slit film	36	42	45	51	64	50	60	70
Polypropylene staple	47	42	45	51	44	30	33	40
Rayon and acetat	78	61	47	26	5	3	3	2
<b>NATURAL</b>								
Cotton	16	15	13	12	4	3	3	2
Wool	80	78	79	43	19	15	16	40
Other	5	5	5	5	5	4	5	6
<b>TOTAL</b>	<b>1125</b>	<b>1314</b>	<b>1583</b>	<b>1754</b>	<b>1507</b>	<b>1390</b>	<b>1600</b>	<b>2345</b>

\*Face fiber only; doesn't include carpet backing.

\*\*CSEN estimates.

Source: Textile Economics Bureau.

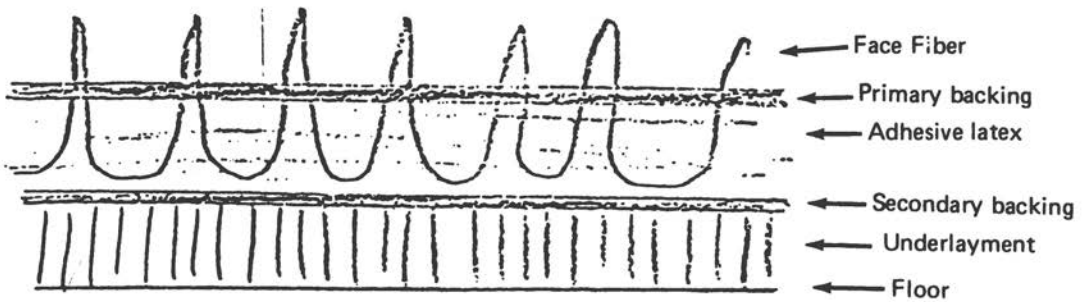

*Figure 4.2. Schematic diagram of carpet assembly.*

The *primary backing* is most often woven jute or nonwoven polypropylene.

A typical *adhesive latex*, which locks the tufts into the primary backing, consists of a carboxylated styrene butadiene rubber (CSBR) filled with 3 parts of calcium carbonate to 1 part CSBR. Recent flammability regulations have led to replacement

of some or all of the  $\text{CaCO}_3$  by alumina trihydrate (ATH). Another adhesive latex material is polyvinyl acetate emulsions (Private Communication, Dr. W. Novius Smith, 1977).

The *secondary backing* may be jute, nonwoven polypropylene, an integral layer of foam rubber, polyvinyl chloride, or polyurethane which then also serves in place of underlayment in an integral construction.

The *underlayment* is most often a rubberized hair, foamed rubber or polyurethane. When the secondary backing is a foam no further underlayment is used.

Variables in the *construction* of a carpet include the face fiber weight (oz/sq yd), pile height, and a variety of style features, i.e., loop, plush, shag, twist, textured, cut-uncut level loop, etc.

### Fire Hazard of Floor Coverings

Since 30 percent of the floor space in the United States is carpeted, it is probable that a significant amount of relatively easily ignited carpet is in use, and, therefore, carpets could likely be involved in major fires. When a carpet is installed by a contractor to an architect's specifications, it must be evaluated like other building materials in accordance with codes for fire hazards. Several dramatic nursing home fires in which floor coverings were implicated have encouraged numerous local, state and federal authorities to establish arbitrary flammability standards; ASTM E-84 (Underwriters Laboratories Steiner Tunnel Test) is the test usually cited in current codes and standards (Figure 4.3).

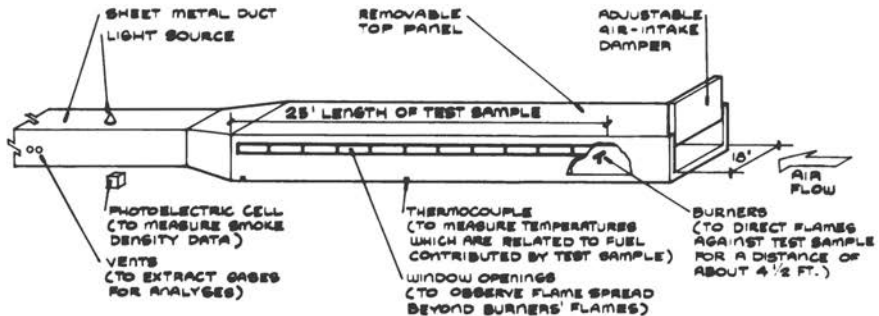

#### TEST REFERENCE

"Test for Surface Burning Characteristics of Building Materials," ASTM Method E 84.

Figure 4.3. Flame spread tunnel apparatus.

Source: M. David Egan, CONCEPTS IN BUILDING FIRE SAFETY, 1978, p. 17, Reprinted by Permission of John Wiley & Sons, Inc., New York, NY.

Two main types of ignition condition must be considered.

1. A small heat source such as burning match or cigarette.
2. Intense heat flux from an established conflagration.

## MATERIALS

The Methenamine Pill test (Federal Register, 1970) (U.S.D.O.C. FF 1-70) appears to be serving well as a screening test for eliminating unreasonably hazardous floor coverings that might ignite and spread flame from a small heat source (Tu and Davis 1976). Because carpets which pass the "Pill Test" can still be hazardous to life and property, methods for measuring response to intense heat flux are discussed in the following section.

The available statistics from reports in the NFPA Fire Journal and from "Flammable Fabrics Accident Case and Testing System" (FFACTS) have been reviewed for incidents of major contribution of carpets to fire spread (Quintiere, et al. 1974). Other recent data analyses from the United Kingdom are also cited. Carpet fire incidents are very rare, e.g., only seven cases were recorded which indicated a major contribution to fire spread by carpets that pass the Pill Test (D.O.C. FF 1-70, discussed below). The five most severe of these fires, from the point of view of loss of life, involved corridors; and one of these was spread by a carpet on the walls without involving the floor covering to any significant extent.

Findings such as the above led the National Bureau of Standards to conduct a series of full-scale fire experiments in a corridor configuration (Denyes, et al. 1973; Fung, et al. 1973). From this program, it was concluded that the major hazard to be addressed is the rapid total involvement of flameover of a carpet assembly, generating large quantities of sight obscuring smoke and toxic gas, and trapping occupants in areas away from the fire source (Huggett 1973). Gas-phase dynamics and radiant heating of the flooring, e.g., by radiation from the heated corridor ceiling, appear to contribute to rapid flame spread in a major way. Thus, a test method to measure the flame spread behavior of a material should involve a radiant heat parameter.

Quintiere and Huggett (1974, 1973) have described and characterized a variety of such test methods:

- ASTM E-84 Tunnel Test.
- ASTM E-162 Radiant Panel.
- UL 992 Chamber Test.
- NBS Model Corridor.
- NBS Flooring Radiant Panel (Benjamin, et al. 1976;  
Hartzell 1974).

They find that the Flooring Radiant Panel (FRP) offers the most promise of obtaining a meaningful design parameter related to building fire hazard. The procedure measures the minimum external radiant flux level necessary to sustain flame spread on flooring materials. The principal elements are shown in Figure 4.4. The horizontally mounted 100 cm long floor covering specimen receives radiant energy from an air-gas fueled radiant panel mounted as shown in the figure. A pilot burner ignites the specimen. The test continues until the specimen self-extinguishes. The distance burned is converted to critical radiant flux, watts/sq cm by reference to the calibrated flux profile chart.

## BUILDINGS

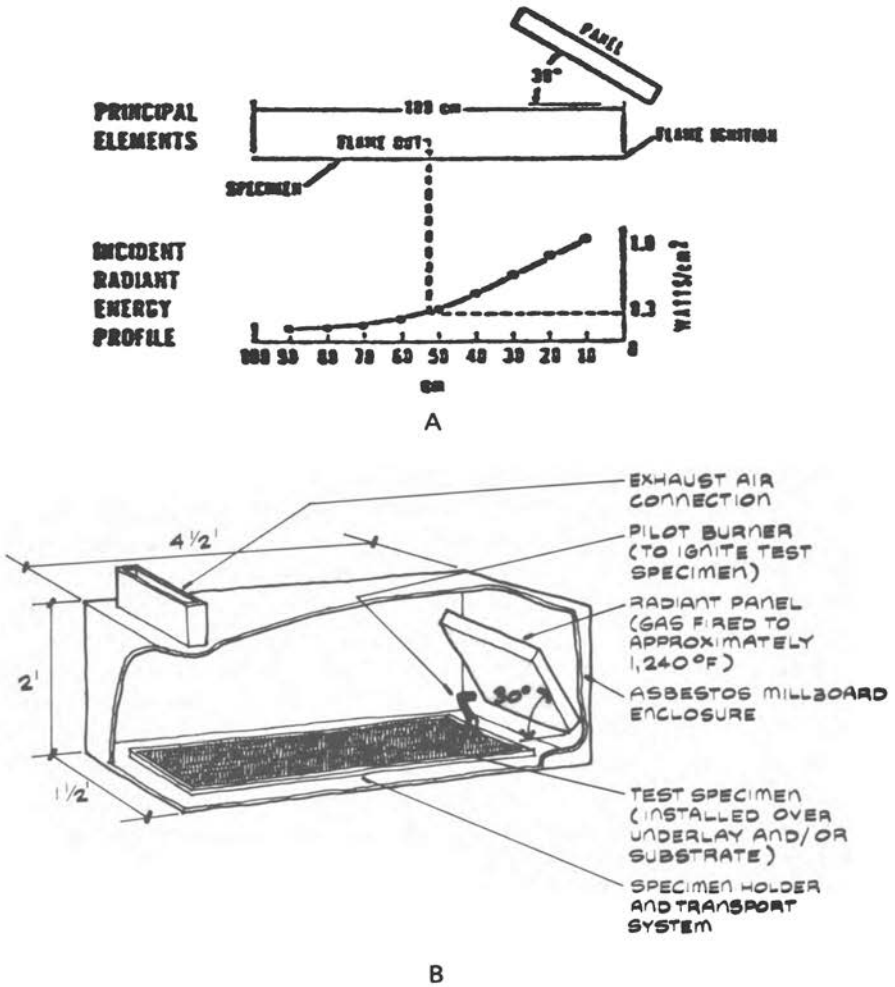

*Figure 4.4 A & B\*. The flooring radiant panel test.*

\*Source: M. David Egan, *CONCEPTS IN FIRE SAFETY*, 1978, p. 23, Reprinted by Permission of John Wiley & Sons, Inc., New York, NY.

FRP tests on floor coverings known to have contributed to building fires were found to have critical irradiance levels of less than 0.1 watts/sq cm (Benjamin, et al. 1976). The critical radiant flux for oak flooring ignition has been determined to be about 0.35 watts/sq cm. Thus, the selection of 0.25 watts/sq cm for residential and commercial occupancies, with specified fuel load levels, seems reasonable to reduce the number of floor covering fire spread incidents. A level of 0.5 watts/sq cm. at the same specified fuel load levels is suggested to accommodate the special problems of institutional occupancies. These values are suggested for corridors, not for

## MATERIALS

rooms or compartments, and may not be necessary when automatic extinguishment systems are installed. Caution must be exercised, however, in using the test in instances where the fuel loading is anticipated to exceed 5 pounds per square foot or there are other combustibles in the corridor. It has been estimated that 36 percent of carpets sold in the contract market would be excluded by a 0.25 watts/sq cm criterion, and 50 percent would be excluded by 0.50 watts/sq cm.

### Factors Affecting Fire Safety of Carpet Assemblies

It is not possible to be definite about the effects of composition and construction details on the fire safety of floor covering assemblies without specifying the test and the fire environment to which the assembly is subjected. Fire safety parameters include the ease of ignition (using a timed burning pill or critical radiant energy), flame spread rate, maximum temperature, rate of temperature rise, total heat evolved, smoke obscuration and toxicity. However, certain generalizations can be made. (Figure 4.5).

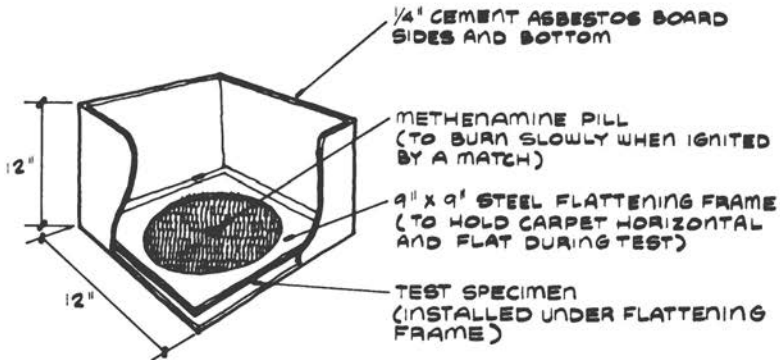

Figure 4.5. Pill test assembly.

Source: M. David Egan, CONCEPTS IN FIRE SAFETY, 1978, p. 22, Reprinted by Permission of John Wiley & Sons, Inc., New York, NY.

Day, et al. (1974) showed a high degree of parallelism among the Pill Test, a modified oxygen index test, and a limiting Radiant Heat test of their own design; all three tests include parameters related to ease of ignition. Day, et al., presented data on 40 carpets with variations in fiber composition and construction. Because of the large number of variables represented, these authors were reluctant to draw firm conclusions. However, one can make a gross ranking of ease of ignition, after allowing for carpet face fiber weight:

#### Ease of Ignition of Carpet Face Fibers (After Day et al.)

Most Difficult to Ignite	Wool or Polypropylene
	Nylon
	Polyester
Easiest to Ignite	Acrylic

Flame spread rate, cm/min., while being radiated at 6.2 watts/sq cm appears to be a face fiber characteristic:

**Flame Spread Rate of Carpet Face Fibers (After Day et al.)**  
(Radiated at 6.2 watts/sq cm)

Slowest Flame Spread	Polyester or Nylon or Polypropylene (approx. 2.5 cm/min Wool or Acrylic (Approx. 7.5 – 10 cm/min.)
Fastest Flame Spread	Viscose (Approx. 125 cm/min.)

Total heat output versus face fiber composition upon combustion under 6.2 watts/sq cm incident radiation is summarized in Figure 4.6

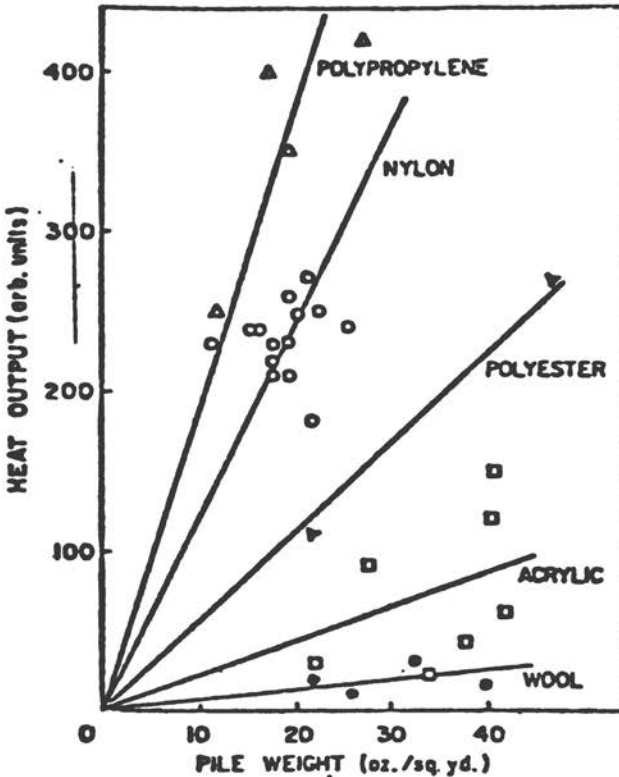

Figure 4.6. Effect of carpet pile weight on the heat output for the following pile fibers: (o) Nylon; (□) Acrylic; (◊) Wool; (Δ) Polypropylene; (▽) Polyester (Day, 1974).

## MATERIALS

In Figure 4.6, the high heats observed for polypropylene and nylon related to their melting and involvement of the total carpet assembly. The low values for acrylic and wool are due to their tendencies to burn rapidly across the surfaces of the pile without consuming the entire carpet assembly.

Carpet construction details play a large role in fire safety. The following factors will decrease flammability as measured by the above tests:

1. Higher face fiber weight.
2. Lower pile height.
3. Jute primary backing rather than polypropylene.
4. Greater weight of latex application.
5. Very even application of latex
6. Alumina trihydrate filler in latex.
7. Direct laying on floor without underlayment.
8. Gluing to the floor to avoid buckling.

Denyes (et al. 1973) observed the very important role of underlay in his model corridor experiments, and attributed the effect to the thermal insulation provided. In his critical experiment a rapidly accelerating flame front was extinguished by the presence of a ½ in. thick by 12 in. wide aluminum under plate.

Flame retardation modifications (FR) of the face fiber have been discussed in Volume 1, State of the Art — Materials, Chapter 3, Section 3.3. The possibilities are to use:

- modified polymers
- chemical additives during fiber formation
- chemical finish treatments to fiber or assembly.

The FR system must be wash resistant, have no adverse effects on aesthetics or physical properties, be toxicologically safe and low in cost (Stoddard, et al. 1975). Stoddard cautions that carpet modifications for attaining other functional properties such as soil resistance, antistatic properties, durability, dyeability and aesthetics may increase flammability.

The Floor Radiant Panel test has shown that the total floor and floor covering assembly is an important factor; the difference in critical radiant flux between a carpet glued to the floor and one laid loose over separate underlay exceeds that of almost any fiber composition variation.

Finally, the location of the carpet installation must be mentioned. While carpet is installed on the floor it can burn only from its top and it can only spread horizontally. Carpets on walls and, more commonly, on staircase treads and risers are exposed to the much greater hazard of vertical burning in an upward direction. The probability is slight that any commercial carpet available today would self-extinguish after ignition while mounted vertically, even in the absence of any incident radiation.

### Future Trends in Carpets

The above discussion has centered on ignition and burning parameters. Smoke



and toxic fumes are of obvious concern, since burning carpets produce large amounts of smoke and gas and more than half of all fire victims are actually toxic gas victims. Light obscuration methods for smoke measurement from carpet specimens are available and in use; the most widely used standards are based on measurements made during the Underwriters Laboratory Steiner Tunnel Test. Fire toxicity measurements represent the frontiers of our knowledge. The test methods (principally "animal titrations"<sup>2</sup>) are as yet insufficiently defined and interpretations of the results insufficiently understood to allow development of meaningful regulations.

Fire-safe carpets to meet the toxicity challenge will probably be derived from thermally stable polymers in which flame resistance is attained through char formation rather than halogen evolution; such materials are known, but they are not yet available in quantities and at low enough prices for widespread use. Aramid (aromatic polyamide, e.g., Nomex®) fiber has been commercially available for a decade. Current volume for all end uses is about 15 million pounds/year. It appears to lack certain aesthetic properties, e.g., light fastness, that are generally deemed essential; its selling price was about twice the general carpet fiber price range at the time this was drafted (1976).

Interim measures for fire safety of carpets comprise education of the public to the hazards, detection by modern fire and smoke detectors, and control by properly designed and installed sprinkler extinguishing systems.

#### 4.4.2.3 Mattresses

Of the furnishings in a typical residence, bedding is one of the items most frequently involved in fires. In one study (see Chapter 3), seventeen percent of single-fatality fires were found to be caused by smoking in bed or smoking in upholstered furniture. In most cases, the fire smoldered during the early stages and the victim was killed by the heated gases or the combustion products, rather than burns. In a series of full-scale tests (Hafer and Yuill 1970), a single cigarette caused ignition in eight out of twenty-two bedding tests. In four of the tests in which a single cigarette caused ignition, heat and carbon monoxide levels were reached that would cause death after a 5-minute exposure and in all cases these levels were reached in 30 minutes. In the twelve tests in which ignition was by an open flame, complete obscuration occurred in 20 minutes or less at a 5-foot elevation.

The National Bureau of Standards (Frye 1972) made a survey and analyzed data on mattress fires. From this they concluded that there was a "need for a national flammability standard for mattresses....." They also concluded that cigarette ignition was an appropriate ignition source on which to base a test method. A standard was developed (Mattress Flammability Standard FF-4-72) and became effective in

---

<sup>2</sup> "Animal titrations" is a method of estimating concentration of toxic substances by the observed effects on standard laboratory animals for a stated period of time.

## MATERIAL

January 1973 (under the provisions of the 1967 Flammable Fabrics Act). Basically this standard requires that mattresses resist ignition by lighted cigarettes. They do not necessarily have to resist ignition by a flame.

In 1970 (Hafter 1970), the market breakdown by mattress type was: inner spring 80-85 percent; polyurethane foam 10-12 percent; latex foam 5-8 percent. Neoprene foam is used in some institutional bedding. Mattress ticking was generally rayon (90 percent) with some rayon-cotton, and other cotton blends.

A generalized inner spring mattress structure is shown in Figure 4.6.

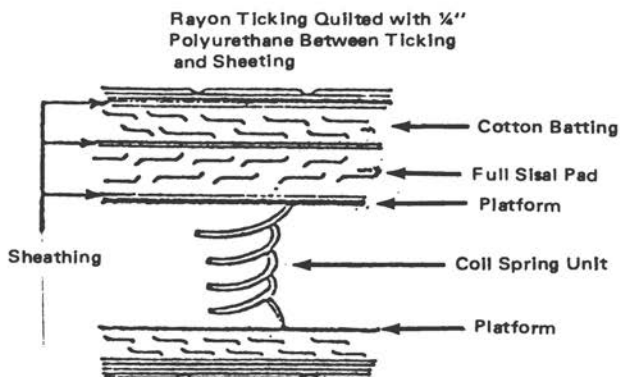

Figure 4.6. Inner spring mattress structure.

A number of studies have been made on the cigarette ignition of cotton mattresses. Boric acid has been claimed (Knoepfler 1976) to be superior to phosphorus compounds or sodium borate in giving resistance to smoldering combustion.

Thin polyurethane foam pads on top of cotton batting have been designed to melt and retract from an ignition source, thus not contributing to ignition.

Standard FF-4-72 became effective in January 1973. Since mattresses have a relatively long life, most of the mattresses in use today do not comply with this standard. Since this is an ignition standard aimed at decreasing incidents of ignition by cigarettes, it does not mean that the mattresses will not burn or that they will not be readily ignited by other ignition sources.

#### 4.4.2.4 Curtains and Draperies

A survey (Moore 1975) was made of 281 fire accident case histories in which curtains and draperies (C/Ds) were involved. The survey included a review of relevant fire incidents contained in files at the National Bureau of Standards, the Bureau of Epidemiology - National Electronic Injury Surveillance System - of the Consumer Product Safety Commission, and National Fire Protection Association as well as those from a literature search. In summary, this survey showed: (1) a major

portion (41 percent) of the home fires started in the living room with bedroom and kitchen incidents comprising 35 percent and 15 percent of the total respectively; (2) Cotton was the most frequently involved fabric with blends of rayon and acetate, cotton and rayon, as well as fiberglass also significantly represented; (3) When C/Ds were involved in a fire, 64 percent of the time they were the first furnishings to be ignited; (4) The match was the most common source of ignition; (5) In cases where C/Ds were involved in the fire sequence, they appeared to play an important part in spreading the fire, often to produce a serious incident. Other surveys strengthen the conclusions above — especially the last one. One survey examining 355,916 fire accident cases lists C/Ds as the highest contributor to "Most Fire Spread," "Severest Hazard in the Home," and "Greatest Property Loss." By contrast, a Bureau of Census survey listing approximately 2,500 fire cases placed C/Ds low on the frequency of occurrence list.

In a number of fires in public places which have taken a heavy toll of human lives, draperies or fabrics used as wall or partition covers have been cited as contributing to very rapid flame spread and generation of panic among the inhabitants. The following are examples of these instances (Moore 1975):

Sao Palo, Brazil, 1974 — Flames reaching up from a lower floor shattered glass in windows above setting curtains afire which in turn promoted spread of fire to that particular floor. This was a vertical chain reaction that helped pass the fire from floor to floor (188 died).

Greek Night Club "Oscar," 1973 — Overhead electrical wires on the floor under synthetic velvet type floor covering ignited the floor covering. Fire spread to walls which were profusely covered with combustible curtains of several kinds (32 died).

Night Club, Detroit, 1929 — Fire of unknown cause started at the foot of a stairway. Entrance hall and stairway were lined with flammable draperies and decorations. Fire traveled swiftly up the stairs to the main dance hall on the second floor (22 died).

Watervliet, Michigan Nursing Home, 1954 — A glassed-in porch was lined with combustible draperies. They were ignited by a portable heater and the two-story wooden nursing home was destroyed (8 died).

Restaurant, New York City, 1936 — Flames ignited draperies and wall hangings decorating the walls and ceiling of a restaurant and caused 150 persons to panic. Nine were killed and 34 injured when they rushed for the only stairway (9 died).

Nursing Home, Billings, Montana, 1953 — Nursing home was destroyed when curtains were accidentally ignited (6 died).

#### 4.4.2.5 Major Appliances

For the purpose of this volume, major appliances are defined as dishwashers, refrigerators, freezers, clothes washers, television sets, electric and gas ranges, electric and gas clothes dryers, room air conditioners, garbage disposers, trash compactors, and electronic ovens. These can be more generally defined as stationary as

## MATERIALS

contrasted to portable units. The consumption of plastics in all U.S. appliances is estimated to have been 0.2 billion pounds in 1960, 1.1 billion pounds in 1975, with projected usage of 1.9 billion pounds by 1980. The rapid growth can be attributed to freedom of design, flexibility of application, ease of fabrication and molding, customer appeal, overall performance and lower energy consumption. The major appliance industry is the fourth largest consumer of plastics in the United States.

Table 4.8 is representative of the broad use of a wide variety of plastics in the appliance industry.

*Table 4.8. Estimated Consumption of Plastics in Appliances*

	<u>Millions of Pounds</u>		
	<u>1971</u>	<u>1973</u>	<u>1980 (est.)</u>
Acrylic	4	4	8
Phenolic	45	48	64
Polypropylene	54	101	223
Polystyrene	232	247	334
ABS	90	158	403
PVC	23	28	74
Polyester	14	32	110
Polyurethane Foam	65	100	210
Acetal	6	6	10
Cellulosics	3	3	4
Nylon	5	5	8
Polycarbonates	4	6	12
Polyethylene	3	4	8
TFE	<u>1</u>	<u>1</u>	<u>2</u>
	549	743	1470

The "major appliances" are estimated to account for at least 75 percent of the total pounds used (see Table 4.9). ABS is certainly one of the fastest growing materials due in large part to its continued and expanded use in refrigerators. The gas and electric ranges use the least amount of plastic and the refrigerators consume the largest quantity.

Specific major applications showing the different types of plastics currently used are given below:

### **Refrigerator**

- ABS and Impact Polystyrene — inner liners, grills, compartment shelves and control housings
- Polyurethane — foam insulation
- PVC — gasketing and breaker strips
- Acetal and Nylon — gears
- Polypropylene — breaker strips, outer parts

## BUILDINGS

### Color TV

FR High Impact Polystyrene and Noryl – housing  
(case) and back

FR Polypropylene – yoke, antenna bracket, tuner  
bracket

FR Thermoset Polyesters – internal functional  
electrical parts

### Dishwasher

Polypropylene – tub

Plasticized PVC – tub coating

### Clothes Washer

Polypropylene – agitator, functional and plumbing  
parts

### Room Air Conditioner

FR Glass-reinforced Polyester – internal  
structures, external housing

Polycarbonate – external housing (one manufacturer  
for small window units)

*Table 4.9. Plastic Content of Major Appliances*

---

<u>Appliance</u>	<u>lb. Plastic/Unit (Industry Average)</u>
Refrigerator	38
Color TV	12
Dishwasher	10
Freezer	10
Clothes Washer	9
Compactor	7
Room Air Conditioner	4
Electronic Oven	4
Disposer	3
Clothes Dryer (Gas/Electric)	1
Electric Range	0.5

---

The "Standards of Safety" are given in UL standard numbered documents for each appliance such as UL484 for room air conditioners. There is widespread use of UL94 *Standard for Safety – Tests for Flammability of Plastics Materials for Parts in Devices and Appliances*. In addition, UL746.50, 746.51, 746.52, etc., cover guides to requirements for applications of polymeric materials in stationary and portable appliances.

In the appliance industry the television segment undoubtedly has received the greatest attention by the Consumer Product Safety Commission with respect to safety requirements. This Commission subpoenaed the industry for its TV Accident

Reports. The Underwriters Laboratory was contracted to prepare a proposed Safety Standard for Television. A committee was formed to prepare this document, which consisted of UL members, consumers, manufacturers, private labelers, flammability experts, etc. The first draft has been presented to CPSC.

In the interim CPSC established a V-2 rating (see Section 5) by July 1, 1975 and a V-1 rating by July 1, 1977 for flammability compliance by the industry with respect to the thermoplastic cabinets. A V-0 level was proposed as a future goal, but no specific date given.

### 4.4.3 Conclusions and Recommendations

#### *Conclusions:*

- The greatest fire hazards from polymeric materials in residential buildings lie in the contents of the building.
- Smoke detectors offer the most cost and time effective way of increasing fire safety in residential buildings (e.g., by providing early warning allowing increased time for occupants to reach safety).
- Upholstered furniture is one of the most hazardous items – usually associated with use of smoking materials.
- Flexible polyurethane foams make a large contribution to the furniture problem.
- Ease of ignition varies greatly with design, cover fabric, and other components used in upholstered pieces.
- Structural foam offers numerous advantages in furniture and other construction and its use is increasing; some proposed applications present significant fire hazards.
- There is a trend toward the use of larger amounts of thermoplastic polymers in major appliances.
- The "Pill Test" (U.S., D.O.C. FF 1-70) aims to eliminate unreasonably hazardous floor coverings that might ignite and spread flame from a small heat source.
- Flammability of carpets is highly dependent on the carpet construction, the substrate on which it is laid, installation variables and location (floors, walls, steps) as well as fiber compositions.
- Neither the customer nor the merchandiser has any significant basis or information on which to base his assessment of safety of carpeting types in various use situations.
- "Smoking-in-bed" mattress fires are a large contribution to fire deaths. Mattresses that do not meet the new, more stringent standard are going to be in use for many years to come.

#### *Recommendations:*

- Continue study and development of safer cushioning systems.

- Require more buyer education by the manufacturers (e.g., through use of labels, literature, etc.) of the fire hazards of foam cushioning.
- Through large scale and mixed contents testing, define more precisely the hazards of structural foam furnishings and components.
- Continue testing and appraisal of flammability of major appliances.
- Define the hazard from use of carpeting on stairways.
- Develop fire safety guidelines for use by merchandisers and customers in selecting residential carpeting.
- Intensify the educational campaign on hazards of smoking in bed.

#### 4.5 Other Occupancies

This section covers major occupancies other than residential where polymeric materials could play a significant role in fire safety. Included are: hotels, motels and dormitories; mobile homes; office buildings; hospitals, nursing homes and related care centers; retail stores, malls, etc.; restaurants, clubs, etc.; auditoria, theaters, exhibition halls, arenas, transportation terminals; educational buildings and industrial buildings. Many of the fire safety materials-related elements of the residential occupancies discussed previously are also common to many of these "other occupancies."

##### 4.5.1 Hotels, Motels, Dormitories and Rooming Houses

Hotels, motels and dormitories are buildings designed to serve as lodgings for transient occupants. The most important priority in fire and life safety for a hotel is the protection of the occupants who, in the event of a fire incident, are likely to be asleep or disoriented in unfamiliar surroundings.

Hotels serve conglomerate functions; i.e., they will generally include shops, restaurants, night clubs, ball rooms and exhibit halls in addition to sleeping accommodations for transients. These other facilities are often a greater fire threat (i.e. due to higher fire load from contents) than the guest rooms. Most codes require that such occupancies be isolated by specified fire resistive walls. The restaurant, club, store and public assembly occupancies are covered specifically in subsequent sections.

##### Structure

Any type of structure may be found in use as a guest accommodation. Examples run the gamut from a fire-resistive high rise hotel to the *wood frame* mansion converted to a college dormitory.

Fire resistive construction is now required for all hotels and dormitories. The use of an existing wood frame dwelling for a high occupancy rate lodging is generally an opportunistic enterprise fraught with danger because structural involvement in a fire may be faster than the occupancy evacuation rate.

The structural elements, and the materials of which they are made (including polymers), are covered in Section 4.3.2.

### Interior Partitions

Interior partitions, discussed in 4.3.2.3, are an important aspect of hotel fire safety. They act as barriers to the lateral spread of fire. Non-flammable masonry walls or poured concrete offer the best barrier. Gypsum board on steel studs is often used; vinyl coated gypsum board combines function and aesthetics. Polymeric foams or sound absorbing blankets or batts of low density anelastic fibers may fill spaces between studs for sound absorption.

All new hotels are required by NFPA Life Safety Code to have 1-hour fire resistance ratings for the corridor walls unless the hotel is equipped throughout with an automatic sprinkler system. Guest room doors are required to have a 20-minute rating. No other openings in corridor partitions; e.g., transoms, grills, are permitted. This assists in controlling the flow of smoke and toxic fumes between sleeping rooms and corridor area.

If a door to a sleeping room is left open in a fire emergency, the remainder of the hotel occupancy could be exposed to smoke, toxic fumes and fire. The NFPA Life Safety Code now requires that all doors to corridors be self-closing. This measure goes a long way toward facilitating the evacuation of guests and ingress of firemen for the majority of hotel fire incidents. However, a fire report by Lathrop (1976) indicates that an enclosed dormitory stairwell was contaminated when an automatic door closer was not strong enough to function against the positive pressure of the draft of combustion products emanating from a corridor fire. Hence an appropriate performance standard for door closers must accompany the Life Safety Code.

### Interior Finish

The interior finish of a structure; i.e., the exposed surfaces of walls, floors and ceilings, is an important factor in the fire safety of a building. A fire starting in the contents of a room eventually may involve the surface finish; then, depending on radiation from the surroundings and its flammability characteristics, the finish may contribute to the fuel load, emit smoke and toxic gases, and spread the fire away from the point of origin.

In new construction, or where new interior finish is applied to existing construction, Class A, B or C finish (Flame Spread Rating up to 200) is permitted in guest rooms. Class A or B (Flame Spread Rating up to 75) is permitted in exits, lobbies and corridors.

The actual flame spread performance of an interior finish material depends on where it is used. The following quotation is from the previously noted report of a fatal dormitory fire (Lathrop 1976): "The destruction of the corridor wall covering was considerable... However, when the fire reached the wide area (central lobby) the spread stopped, indicating the radiation between the corridor walls was a factor... The vinyl wall covering had a flame spread rating of zero, according to the E162 Radiant Panel Test.



## BUILDINGS

The fire properties of surface covering systems are highly substrate-dependent (Waksman and Ferguson 1974). Products evaluated by Waksman included varnishes, epoxy paints, nylon paints, textured spray coatings, vinyl and acrylic-vinyl sheets, jute fabric, prefinished plywood and gypsum wallboard. Substrates used were asbestos cement board (ACB) and painted plywood. Thicknesses of finish were varied. Some of the covering materials which had low flame spread ratings (ASTM E 162) on ACB yielded values in excess of 200 on painted plywood. Smoke density values obtained on coverings applied to painted plywood were much higher than those obtained on ACB. Relatively thick coverings of vinyl yielded relatively high concentrations of HCl in a fire. Thus, results measured for a finish on essentially noncombustible ACB (as presented in the test) are not applicable when applied on a more combustible surface or at another thickness.

### Dormitories

The fire and life safety provisions presented above for hotels (and motels) are considered by NFPA to provide a suitable level of safety for dormitory occupancy. In new buildings construction is limited to non-combustible materials. Vertical openings (stairwells) are required to have appropriate fire resistive enclosures. Unprotected vertical openings may be present in existing buildings of not more than two stories if the buildings is protected by an automatic sprinkler system.

### Lodging or Rooming Houses

Rooming houses represent an occupant loading greater than normally found in one- and two-family dwellings, but generally less than that of hotels or dormitories. The NFPA Life Safety Code requirements in these cases are scaled to provide an intermediate level of fire and life safety.

### Contents

The contents of hotel rooms are essentially the same as found in private residences and discussed earlier —

- Furniture
- Floor Covering
- Mattresses
- Curtains and Drapes

Hotel room contents differ from private dwellings in that the guests bring in only a few personal possessions (mostly clothes) in contrast to the accumulation of sundry items one finds in a private home. For the most part the contents are controlled by the management.

Hotels also differ from private dwellings in that if fire safe furnishings become available at realistic costs, they would be readily adopted, either voluntarily or by regulation.

Traditionally, furniture, upholstery and fabric decor have been made from natural

## MATERIALS

materials; i.e., wood, cotton, wool, rubber, whose burning characteristics, though not fire safe, are well known and accepted risks. Fires involving foamed plastic furniture have reportedly grown faster than those involving traditional materials. From a realistic point of view, furnishings of either natural or synthetic polymers are the weakest link in the chain of hotel fire safety.

Current programs on the fire safety of furnishings are covered in 4.4.2.

Within the present state-of-the-art of materials, there is much that can be done to improve the fire resistance of chair coverings and cushions. In fact, current development programs have already produced cushion materials and covering materials of substantially higher resistance to ignition and flame spread. The National Bureau of Standards is developing new testing methods that measure the response of materials to cigarette type ignition sources. Moreover, the Consumer Product Safety Commission is considering the promulgation of a mandatory standard which would eliminate easily-ignited upholstered furniture from the market place.

### Occupants

Hotel guests in high rise hotels know the elevator as the only way out. The use of automatic elevators during a fire sometimes has a fatal ending because the automatic features in some systems cause the elevators to move to the floor with the most fire and smoke (Watrous 1972). Aside from the warnings not to use elevators in a fire emergency, efforts should be devoted to modify the automatic controls to eliminate the problem. (Other significant elevator problems during a fire emergency comprise: a) smoke migration into elevator shafts, b) distortion of door mechanisms, and c) warping of guiderails).

Hotel guests occupy individual rooms behind closed doors. For fire safety reasons there are no transoms or other openings between the individual rooms and the corridors. Fire starting in any one room would be confined to that room for a time without activating a smoke detector/alarm located in the corridor. Bukowski (1977) estimates that the sleeping occupant would not be warned in time to escape the lethal conditions in the bedroom unless there were also a detector in the bedroom. Smoke detectors are discussed in Chapter 6, Section 6.2.2.1.3. Sprinklers to suppress an individual fire are desirable, but may not act before the accumulation of toxic fumes becomes lethal in the room of fire origin.

It is common in hotel fires for guests to pay little attention to fire alarms, thinking that the sounds are annoyances that do not concern them (Fire Protection Handbook, 1976). Voice inter-communications to transmit alarms and evacuation instructions throughout the building are under consideration in new installations.

### New Developments

Work sponsored by NASA at Battelle Memorial Institute (Hillenbrand and Wray 1974) was conducted to assess the potential of materials with improved fire

## BUILDINGS

**Table 4.10. Furnishings and Materials in Four Room Fires**

	Typical Room	Improved Room	Space-Age Room	Mixed-Load Room
<b>Mattress (single bed size)</b>				
Cover	Cotton	Nomex®	Durette 400-1®	Durette 400-1®
Padding	Cotton felt; sisal pad	HR Foam® (3-pound)	HR Foam® (2-pound) plus Refset L-3203-6®	HR Foam® (2-pound) plus Refset L-3203-6®
<b>Box spring</b>				
Cover	Cotton	Nomex®	Durette 400-1®	Durette 400-1®
Padding	Cotton felt; sisal pad	HR Foam® (3-pound)	HR Foam® (2-pound) plus Refset L-3203-6®	HR Foam® (2-pound) plus Refset L-3203-6®
Frame	Wood	Kem Gard Latex Paint® (fire-retardant) on wood	Refset L-3203-6® on wood	Refset L-3203-6® on wood
<b>Hollywood frame Headboard</b>				
	Metal	Metal	Metal	Metal
	Wood (pecan)	Formica 3855® on	Norgan Laminated with FX-Impregnated Fiberglas®	Norgan Laminated with FX-Impregnated Fiberglas®
<b>Bedspread</b>				
Two sheets; one pillow cover; Blanket	Cotton 50% cotton-50% polyester	Nomex® Nomex®	Beta Glass Durette 400-6®	Beta Glass Durette 400-6®
Pillow	Polyester fiber; cover: 50% cotton-50% polyester	HR Foam® (3-pound); Ticking: Nomex®	Needle Batt Durette 400-11®. Between two plies of Durette 400-2® HR Foam® (2-pound) plus Refset L-3203-6®; cover: two plies of Durette 400-6®	Needle Batt Durette 400-11®. Between two plies of Durette 400-2® HR Foam® (2-pound) plus Refset L-3203-6®; cover: two plies of Durette 400-6®
<b>Auxiliary furniture</b>				
<b>End tables</b>				
	Pine	Formica 3855® on pine treated with Kem Gard Latex Paint® (fire-retardant)	Refset L-3203-6® plus Scheuffelin paper on pine	Pine
<b>Lamps</b>				
Lamp shades	Ceramic	Ceramic	Ceramic	Ceramic
Upholstered chair	Paper parchment	Fiberglas®	Durasan®	Paper parchment
<b>Upholstery</b>				
	Polypropylene	Fontant® (Proban treated wool)	Durette 400-6®	Polypropylene;
Frame	Oak	Kem Gard Latex Paint® (fire-retardant) on oak	Oak plus Refset L-3203-6®	Oak
Padding	Polyurethane	HR Foam® (3-pound)	HR Foam® (2-pound) plus Refset L-3203-6®	Polyurethane
Bureau	Pine	Formica 3855® on pine. Pine coated with Kem Gard Latex Paint®	Refset L-3203-6® plus Scheuffelin paper on pine	Pine
Bookcase	Pine	Formica 3855® on pine. Pine coated with Kem Gard Latex paint®	Refset L-3203-6® plus Scheuffelin paper on pine	Pine
<b>Floor covering</b>				
Carpet	Nylon with jute backing	Untreated wool	Fiberglas®	Nylon with jute backing
Pad	Fiber pad	HR Foam® (3-pound)	HR Foam® (2-pound) plus Refset L-3203-6®	Fiber pad
<b>Wall covering</b>				
	Latex paint	Palusol® (sodium silicate board) Fiberglas® covering	Laminite® (14-in.) plus Durasan® (5-mil) covering	Latex paint
Ceiling	Latex paint	Ceramagard® tile	Laminite® (14-in.) plus NASA-Ames wood panels plus Cellulose-Urea Formaldehyde Formulation foam panels	Latex paint-cotton
Drapes	Polyester-cotton	Fiberglas®	Beta Glass	Polyester-cotton
Door	Hollow core, birch	Solid wood	Norgan Laminated with FX-Impregnated Fiberglas®	Hollow core, birch

properties, produced by advanced technology, for use in bedroom furnishings. There were four full-scale fire tests (Table 4.10):

1. Furnishings from conventional retail sources.
2. Materials selected from among the best commercially available.
3. New materials possessing improved fire retardant properties and not yet commercially available; i.e., space-age furnishings (Space-Age Room).
4. Furnished as in the first test, except that the bed and bedding materials were as in the third test.

Table 4.10 describes the materials used.

## MATERIALS

- (1) The *typical room* ignited easily and burned rapidly.
- (2) In the *improved room* there was slower fire spread, but the room was consumed; and a larger amount of smoke was produced.
- (3) The *space-age room* did not ignite under the common ignition condition, but could be made to burn, relatively slowly, by a larger ignition source.
- (4) The *mixed room ensemble* demonstrated the reduction in fire spread attainable by placing fire retardant materials in the important paths for fire spread.

The hazard due to smoke and toxic gases became severe in all but the space-age room in 3–5 minutes. Table 4.11 shows the gaseous combustion products encountered. Note the moderation of hazard obtained by the controlled fire of the mixed-load room.

**Table 4.11. Summary of Gaseous Component Concentrations Comparison with Published Values for Hazardous Concentrations**

	Danger <sup>a</sup> Level	Typical Room <sup>a</sup>	Improved Room <sup>a</sup>	Space-Age Room <sup>a</sup>	Mixed-Load Room <sup>a</sup>
Carbon Dioxide (%)	> 8	8	3–4	1	3(7)
Oxygen (%)	<14	12	17	20	16
Carbon Monoxide (%)	0.1–0.2	1.5	0.5	Small	1
Hydrocarbons (ppm)	—	50,000	150	—	5,000
Sulfur Dioxide (ppm)	50–100	100(400)	200	Small	50(100)
Oxides of Nitrogen (ppm)	100–150	150(300)	100	15	100(300)
Hydrogen chloride (ppm)	1000–2000	92	280	7	23
Hydrogen fluoride (ppm)	50–250	3	0.7	0.8	0.2
Hydrogen cyanide (ppm)	100–200	710	105	2.3	5.6
Particulate (mg/m <sup>3</sup> )	—	5.0	3.3	0.057	0.37
Aldehydes (ppm)	—	120	1,410	42	210

<sup>a</sup> Sources of the danger level estimates are listed in the *Final Report*, p. 65.

<sup>a</sup> Values in parentheses indicate peak values; others are average values during first ten minutes for those measured continuously, and for the entire fire for those measured as a single integrated sample.

### Conclusions:

- Hotel structures with fire resistive elements and compartmented with walls having code-specified endurance ratings rarely contribute to fire hazard.
- Even though interior finish materials; i.e., wall and floor coverings may have low nominal flame spread ratings, they sometimes burn and spread flame, smoke and toxic combustion gases. The safest practical materials obtainable are not always required by codes in all locations in a hotel.
- Furniture, bedding and textile decor are the most flammable components in a hotel fire. Except for carpets and mattresses, there are no regulatory specifications. In most furniture applications, there are no commercially available completely fire safe materials, though there are materials and constructions which are less hazardous than some that are in use.

**Recommendation:** Develop better criteria for selection of fire safe interior finishes and furnishings and require use of the safest practical materials.

### 4.5.2 Mobile Homes

For a number of years the percentage of single family residential houses repre-

sented by mobile homes has increased sharply. They now constitute about 20 percent (about 300,000/yr) of the new single family homes. This percentage can be expected to increase as the cost of new housing continues to increase. Today the average mobile home contains 600 lbs of synthetics. In 1975 over 90,000 metric tons of polymers went into 330,000 units and consumption is expected to reach 250,000 metric tons by 1988 (Martino 1976). Innovative use of plastics is frequently first seen in mobile homes.

The construction of mobile homes and their fire statistics are discussed separately here because they are substantially different from conventional one and two family homes.

Mobile homes are generally 8 to 14 feet wide and up to about 70 feet long. Some are transported in half-width sections and put together on site to give finished homes up to 24 feet wide. The homes are constructed on a steel I-beam frame to give rigidity during over-the-road transportation. They have wood floor joists, generally with particle board subflooring. The walls are framed with 2" X 4" wood studs, or metal studs, on 16" centers. The walls have various types of sheathing and siding. Plastic foam backer-board or sheathing can be used (HUD-standards) if it has a flame spread rating of less than 75 and is separated from the interior by at least 2 inches of mineral insulation. Siding is generally aluminum but vinyl siding is being strongly promoted for its resistance to denting during transportation and ease of maintenance. Plywood and other wood siding is also used.

*Interior walls* have generally been 3/16" plywood. In most cases this has been applied directly over the studs but some builders are now backing it with gypsum board. Others use vinyl coated gypsum board. The reasons for not using gypsum board heretofore have been added weight and cracking during transportation.

*Partitions* are generally 3/16" plywood on 2" X 3" studs. As with the walls, some builders are now using gypsum board in the partitions.

*Insulation* is generally glass fiber between the studs, under the floor, and between the rafters. Foam laminates are sometimes used over the rafters. One builder has sprayed polyurethane foam on the back of gypsum board on metal studs before adding sheathing and siding.

*Ceilings* are usually fiber board tiles or planks directly on the joists. The roof framing is wood truss construction with wood sheathing and metal covering. Ceiling heights are generally 7' 6" or less.

The *heating units* are generally wall units or units in small closets.

*Furnishings* are considered to be the same as discussed for other residential occupancies.

*HUD Construction and Safety Standards* and various codes now control many fire safety aspects of mobile home design and construction such as protection around the furnaces, hot water heater, kitchen stove; location and type of insulative foams, and heating tapes used on under-the-floor plumbing lines. Smoke detectors are also now required. However, it should be kept in mind that many thousands of

## MATERIALS

units were constructed prior to issuance of these regulations; these units will continue to be occupied at hazard for many years.

Statistics (NFPA No. FR 75-2) show that heating, cooling, and electrical equipment provide the *ignition source* in a much higher percentage of the fires in mobile homes (85 percent) than in conventional homes (less than 50 percent). The largest percentage (27.6 percent) of mobile home fires start in the kitchen, whereas the largest percentage (37.2 percent) of conventional home fires start in the living room. Heating tapes were responsible for 12 percent of the electrical equipment ignitions.

*Interior finish* seems to have a much greater part in fire spread in mobile homes than in conventional homes. It was the "material-first-to-ignite" in 41.3 percent of the cases compared with 25.2 percent for conventional homes. A characteristic feature of most fire reports on mobile homes (NFPA-No. FR-72-2) is the speed with which the fire spreads throughout the structure. The wood paneling is generally given as the reason for this. Other factors that contribute to rapid spread are lower ceilings, relatively long and narrow halls, generally smaller rooms, and fewer heat sinks in walls, furniture, floor, etc.

*Future trends* in mobile home construction are towards use of more synthetic polymeric materials (Martino 1976). These uses include vinyl siding, plastic tub and shower units, plastic piping, various composite panel wall and partition structures, more carpeting in place of vinyl tile or roll goods, structural foam furniture and cabinetry, plastic window frames, and plastic glazing. Although these changes would add fuel load or, more importantly, add potential for *rapid* fire spread, there are other trends that should greatly reduce the fire hazard of mobile homes. Some of these are: the HUD requirement for smoke detectors, better fire resistance in areas around heaters and stoves, safer electrical heating tapes, and the increased use of gypsum board in the interior finish. This latter item could be the biggest factor in increased fire safety of mobile homes.

### *Conclusions:*

- Construction of mobile homes is considerably different from that of conventional housing and undergoes continual change. It is often the first place where new housing applications of polymeric materials appear.
- Interior finish plays a dominant role in the spread of fire in mobile homes. Unbacked thin plywood over large areas of the inside of a structure is a serious fire threat.

### *Recommendations:*

- Require thorough large scale testing on systems that incorporate new applications of polymeric materials in mobile homes. The scenario approach should be used to assist in designing "realistic" tests.
- Conduct detailed studies to define the potential hazard of currently used interior finish systems. Consider requiring all walls and ceilings to be made of gypsum board or comparable materials.

- Promote (by suitable incentives, etc.) use of smoke detectors and upgrading of fire protection around furnaces, heaters and stoves in older mobile homes.

### 4.5.3 Office Buildings

Many of the aspects of construction, design and contents discussed under hotels, motels, dormitories and rooming houses (Section 4.5.1) hold equally well for office buildings. A major difference is that office building occupancy is generally during the day whereas hotels, etc. present the greatest fire hazard to occupants during hours they are asleep. Like hotels, office buildings frequently are a conglomerate of functions including shops, restaurants, clubs, etc. Many of these are often a greater fire risk than the office occupancy.

All types of building structure can be found in the broad category of office buildings. They vary from converted residences of wood frame construction to fire resistive high rise structures. The elements of construction such as outside walls, partitions, interior finish, insulation, etc., along with the design aspects such as exits, compartmentation, air handling system, elevators, penetrations, detectors, alarms, communication systems and extinguishment systems are all extremely important aspects of fire safety in office occupancies.

Relative to polymeric materials the items most often involved in or responsible for the initiation and growth of office building fires are interior finishes, furnishings (particularly upholstered pieces), thermal insulation, electrical insulation, floor covering and draperies.

The following descriptions of two actual office building fires serve to highlight the interaction and importance of building elements, design factors and materials usage in the overall fire problem.

On August 5, 1970 the One New York Plaza fire occurred. The fire occurred on the 33rd floor of the building. It was detected by a guard who pulled the fire alarm box and then took the elevator to the first floor to notify the building guards of the fire. Several people took an elevator to the 39th floor to notify employees of the fire. Their elevator automatically stopped at the 33rd floor and smoke and flames rushed in. The individuals on the elevator perished. Within the next few minutes while evacuation of the building was occurring smoke was drawn in the air conditioning system and the smoke detection equipment at the fan shut down the supply fans and sounded an alarm, finally, in the fire company. It took five hours for the fire to be brought under control. Two lives were lost and thirty men were injured, and ten million dollars damage was caused. One New York Plaza is a typical modern skyscraper completed early in 1970. It is 50 stories above grade and three stories below grade. It has reinforced concrete center core. This core contains elevator shafts, stair towers, rest rooms, utilities, and air conditioning supply and return air shafts. Steel beams connect the core to the columns at the outside wall. The walls are made of aluminum panel window sections. The inside face of the curtain wall was insulated with a polystyrene foam board. The foam board was in turn covered by gypsum board only where visible. Hung ceilings were acoustical



## MATERIALS

tile. The space below between hung ceiling and the floor contained a number of items, for example, air supply ducts, lighting fixtures, power lines in conduit, telephone cables, and communication cables. Many of these were insulated with polyvinylchloride. A heated and cooled air distribution system was present in the building. All of the air supply fans were protected by a fire alarm. The fire was first detected in the concealed ceiling space of the 33rd floor. This happened to be in the vicinity of the telephone equipment room. The exact point at which the fire originated was not identified. This space contained a number of cables having plastic insulation. Fire apparently spread to the exposed polystyrene foam in the walls and caused flaming droplets or flaming gases. From this point it appears that the furniture was involved and the fire was accelerated by the flammable gases given off by the foamed polyurethane. The fire spread to the 34th floor through openings into the electrical and telephone closets, from concealed spaces and other openings such as the mail chute, and electrical connections in the floor. Damage was extensive to the building. The outer skin of the building and aluminum flashings were melted above the 33rd floor. Furniture and equipment was completely destroyed on the 33rd floor. The bases of office chairs were melted and steel beams were either twisted or deflected on that same floor. The telephone and electrical equipment was completely destroyed by melting of plastic parts, burning of insulation and shorting. On the 34th floor damage occurred to the furniture, and beams were also deflected and distorted. (This information was from a report issued by the New York Board of Fire Underwriters Bureau of Fire Prevention and Public Relations and written by W. Robert Powers).

The World Trade Center fire occurred in New York City on February 13, 1975. The fire was reported in the North Tower, from the 9th to the 19th floor. The fire was discovered by a porter finishing his chores on the 12th floor. The alarm was turned on, it alerted the fire department. One minute after the manual alarm was received smoke detector and air conditioning alarms operated. Fresh air was being blown into the core area to keep it free of smoke and air. The fire on the 11th floor became difficult to extinguish. It was not recognized immediately that the fire had spread to other floors, but it had apparently gone to the 12th and 13th floors igniting files in these office areas. It apparently had spread through telephone closets. This was the case also for the 9th through the 19th floor. All of these fires were readily extinguished. On the 11th floor, the telephone panels were completely burned out, and wiring in the telephone closets on the three floors had been burned out. There was severe damage on eight other floors. Four steel bar trusses were distorted slightly. On the 11th floor there was an executive office furnished with wooden desk and credenza, sofa, four chairs and two lamp tables. Cushioning was of foamed polyurethane with dacron covering and the rug was wool pile on rubberized felt. The remainder of the floor contained other private offices and open office areas with usual desks, chairs, files, file room and lunchroom. The stuffed furniture burned fiercely and the fire spread as a result. The fire entered the file room where



numerous records were stored. All of the shutters were opened and so the records were destroyed. In addition, a gallon can of duplicating fluid was set afire. Flash-over occurred breaking several windows. The outer skin of the building suffered no smoke and heat damage because the air flow was inward. Telephone cables were ignited. There were some openings around the cables where they passed through the telephone closet walls. Because of louvers in the telephone closet door, fire penetrated the closet to ignite telephone panel blocks and cables as a result of the fire spread to upper and lower floors. There was no fire stopping for spaces around the cables. Polyethylene and polyvinylchloride cable insulation and plastic panel blocks burned quite readily so that all combustibles including the fire retarded wood paneling on the telephone closet walls were destroyed. The Twin Towers were unique construction-wise. The exterior walls are load-supporting walls. Large steel trusses are connected to the interior core and are part of a four inch concrete floor they support. The core contains elevator, stairs, rest rooms and building services and consists of numerous steel columns with concrete floors. The interior face of the exterior columns is protected by plaster. The spandrel beam is sprayed with vermiculite plaster to provide vertical fire separation between windows. The steel bar trusses were sprayed with asbestos fiber to protect them from fire. There was a manual fire alarm box on each floor that provides two-way communication with the police desk in the basement. At the time of the fire smoke detectors were being installed. Telephone power and pipe shafts are located in the outer section of the core. Wiring is in conduit or vented ducts with fire-stopping at each floor. Openings around conduits in walls and floors are fire-stopped with plaster and mortar. Telephone shafts have louvered doors. Cables insulated with polyethylene and polyvinylchloride passed through an opening in the ceiling to the closet above and through holes in the wall to other telephone closets on the same floor. None of these openings were fire-stopped; they were the cause of fire spreading vertically from one closet to another. (The previous information was developed by W. Robert Powers in the report entitled, "One World Trade Center Fire," report by the New York Board of Fire Underwriters).

*Conclusions:*

- The polymeric materials most often involved in or responsible for initiation and growth of office building fires are interior finishes, furnishings, electrical insulation, floor covering and draperies.

*Recommendations:*

- Increase use of detectors and sprinkler systems.
- Develop better methods and criteria for definition and selection of interior finishing and furnishings that are more fire safe.

#### **4.5.4 Hospitals, Nursing Homes, Related Care Centers, and Other Custodial Buildings**

These occupancies have in common the low mobility, relatively high density and unreliability of action of many of the occupants. Modern hospitals are of fire

## MATERIALS

resistive construction and codes and standards delineate many aspects of design related to fire safety (NFPA No. 101). Older small hospitals and nursing homes that are structures converted from old large residences lack many of these features. Thus, present-day usage ranges from converted frame residences with a wide variety of walls, ceilings, inside partition types, etc. to fire resisting structures with fire rated partitions, ceiling, doors, etc. with advanced elements of design for fire safety (ref. Cook 1975 VA concept). However, in the numerous disastrous nursing home fires that have been documented since 1970, most of the deaths have not occurred through failure of the structure, but from exposure to combustion products from the interior finishes and the contents of patients' rooms. Many patients in these same fires suffered no harm since the doors to their rooms were closed and the room was not invaded by fire or fumes (Degenkolb 1976).

Ignition frequently occurs through use of smoking materials. Ease of ignition could be decreased by selection of more fire resistive bedding, metal waste containers, fire resistive chairs and fire resistive drapes or curtains (or none). There is controversy over requiring smoke-triggered self-closing doors on patients' rooms; but, there seems to be uniformity of opinion that the patients' rooms are the best first refuge and closed doors (not necessarily fire rated doors) can save many lives from fires in these occupancies. Particularly in older structures sprinklers and detectors should be used to the extent possible to decrease fire hazard.

With current trends in institutional care to make the surroundings as "home-like" as possible the added fire hazard of many "home-like" furnishings like upholstered furniture, drapes, structural foam furniture, etc. should be kept in mind. (See 4.3).

Disposable items represent a high and increasing use of polymeric materials in hospitals and nursing homes. This covers a wide range of items such as gowns, sheets, basins, bed pans, food service, laboratory ware, etc. This, to date, has not proved to be a fire problem and most codes require storage of these items in fire resistant and sprinklered areas. In smaller, older institutions and converted residences such practices are probably less prevalent. The hazard from such materials is primarily in furnishing a potential "first to ignite" material that will burn rapidly with a high rate of release of heat, smoke and fumes.

The polymeric materials, regularly found in the rooms, are mattresses, bedding, pillows, furniture, draperies (if used), carpeting or other flooring, interior finish of walls and ceilings, doors, trim, etc. These are essentially the same as might be found in residential bedrooms (see Section 4.4.2).

### *Conclusions:*

- A large percentage of fire deaths in health care facilities are patients in rooms near the room of fire origin (and often containment) who are killed by toxic combustion products.
- The high use of combustible disposables now used in most health care facilities has not as yet been a significant factor in fires.

- Patient room fires frequently occur through use of smoking materials.

*Recommendations:*

- Develop a system solution to bedding fires in health care facilities considering use of different materials, detector systems, extinguishment systems and/or better means of control of smoking materials.
- Develop practical systems for closing patient room doors in event of a fire in a room or nearby room.

#### 4.5.5 Retail Stores, Malls, etc.

Supermarkets, department stores, drug stores, shopping centers, etc., are considered to be mercantile occupancies, i.e., the facilities which sell and display merchandise.

As in the case of educational facilities, the people (customers) are generally highly mobile, and can be expected to respond rapidly to any fire emergency. The types of design and construction in place are obviously many and quite varied, with the long history of buildings built specifically as stores and the many dwellings converted at least in part to stores. The content of the combustible materials in stores varies even more when one considers furniture stores, carpet stores, drug stores, paint stores, clothing stores, etc.

Egress, i.e., safety of life, is of prime importance; saving the structure is important, but secondary.

A review of large loss-of-life fires in stores (12 or more deaths) shows only five such events within the United States since 1900. Four of these resulted from explosion — natural gas, LP-Gas, sewer gas leakage, or gun powder. This clearly does not imply that store fires do not occur, but containment of the fire and greatly improved egress have led to a considerably lower loss of life. This record is not repeated in foreign countries where major fires occurred even in the 1960's and 1970's. These, however, involved stores without sprinkler systems.

The U.S. Model Building Codes now are more stringent in their requirements for both the construction and automatic fire protection of stores located within urban areas. This is further reflected in the automatic sprinkler requirements of the NFPA Life Safety Code. The ultimate effect of both the Building Codes and the NFPA Life Safety Code has been the remarkable life safety record of American stores.

This has led to most sizable stores in the United States being of fire resistive construction with the additional requirement of an automatic sprinkler system. The NFPA Life Safety Code does require total sprinkler protection in all of the following types of mercantile occupancies<sup>3</sup>:

---

<sup>3</sup> Relatively small stores that are either less than 15,000 sq. ft. in area if one story in height, or less than 30,000 sq. ft. gross area if over one story in height, are not required to meet either stringent construction requirements or the provision of an automatic sprinkler system. These do not represent a severe threat to life safety nor a significant threat to property protection.

## MATERIALS

1. In all one-story buildings over 15,000 sq. ft. in area.
2. In all buildings exceeding 30,000 sq. ft. in gross area.
3. Throughout floors below the street floor exceeding 2,500 sq. ft. in area when used for the sale, storage, or handling of combustible goods and merchandise.

Interior finish is limited to the following components. The interior finish of exits must be Class A or Class B. This allows materials of up to 75 flame spread rating to be used in all exits. In sizable mercantile occupancies (Class A and Class B stores), interior finish of the ceiling material must be Class A or Class B (up to 75 flame spread) unless a sprinkler system is present. Where sprinkler protection is provided, the ceiling material may be permitted to be Class C (up to 200 flame spread). The permissible construction for the exposed surface of walls in Class A and Class B stores is restricted to Class A, Class B, or Class C interior finish materials (up to 200 flame spread). Further, in any mercantile occupancy, exposed portions of structural members complying with the requirements for heavy timber construction may be permitted. Laminated wood, if provided, must not delaminate under the influence of heat. Class C stores are permitted to have Class A, B, or C interior finish (up to 200 flame spread) throughout the store, with the exception of the exit construction previously discussed.

Hazardous areas used for heating, air conditioning, or maintaining the facility, in many cases, provide the source of ignition for fires. The following requirements are imposed on areas housing such occupancies:

1. Any area used for general storage, boiler or furnace rooms, fuel storage, janitor closets, maintenance shops including woodworking and painting areas, and kitchens must be separated from the remainder of the mercantile occupancy by construction having a fire resistance rating of not less than one hour.

2. All openings into these areas must be protected by self-closing fire doors of suitable rating for installation in fire resistive construction of one hour. These requirements are waived in mercantile facilities that are protected by automatic extinguishing systems.

3. Any areas that house high hazard content are required to be isolated by fire resistive construction and protected by automatic sprinkler protection.

The covered small shopping center in some ways is a collection of individual mercantile facilities combined under a single roof. This approach to merchandising grew very rapidly in the sixties and early seventies and with it came the requirements for new codes. These codes are now established and relate first to the safety of individuals.

The covered mall and all buildings connected thereto are to be provided throughout with an electrically supervised automatic sprinkler system in accordance with NFPA requirements.

The mall must be provided with smoke control in accordance with NFPA requirements: Under fire conditions, any build-up of smoke in a tenant store could ultimately find its way into the covered mall due to the open storefront configuration. Effective means of smoke control in the covered mall proper are essential in

order to assure its continuous use as a smoke-free primary way of exit access.

### *Conclusions:*

The merchandise in retail stores represents potentially a very significant fire hazard. However, the statistics on the loss-of-life in stores (12 or more deaths) show only five such events in the United States since 1900. The safeguards, i.e., smoke detectors, sprinkler systems etc., appear to have been effective in reducing large losses. Statistics on smaller stores, i.e., one family stores, etc., are not readily available.

### *Recommendations:*

Promote by insurance incentives, educational campaigns, etc., the installation of smoke detectors, sprinkler systems, etc., in small, older family-owned type of mercantile stores.

Continue the successful record of low loss in fires in retail stores by constantly updating the requirements as new approaches to fire safety become available.

### **4.5.6 Restaurants and Nightclubs**

According to NFPA statistics in 1975 there were 23,700 fires in restaurants, taverns and nightclubs which resulted in \$62,400,000 estimated property loss (Fire Journal, Nov. 1976). Because of the special problems of this type of occupancy, multiple deaths in fire situations are a serious concern.

Table 4.12 shows the causes of restaurant fires: incendiary, electrical, cooking and smoking. The incendiary ignitions reflect a changing society; in 1950-55 less than 2 percent of restaurant fires were of incendiary origin, whereas in 1971-72 32 percent of reported restaurant fires were set deliberately (Ottosan 1973).

### **Structural**

Restaurants and nightclubs can be found in any type of building, e.g., at the street level in a fire-resistive high rise building, in the pent-house of a fire-resistive hotel, a one-story building of ordinary construction alongside the highway, or in a renovated wood frame building. One multiple fatality restaurant fire occurred aboard a 226 foot long floating steel pontoon (Stone 1973).

### **Stair Enclosures**

Fire resistive enclosure of stairs and self closing doors are a vital defense against vertical fire spread. Alternatively, automatic sprinkler systems should be installed and finish materials of low fire spread rating should be used on stairways. In the fire reports that follow in this section, the prices paid for ignoring this guide will be very apparent.

### **Interior Finish**

As in all the previous occupancy discussions, interior finish plays a key role in spreading a fire. The NFPA Life Safety Code requires Class A materials (Flame

## MATERIALS

*Table 4.12. Causes of Restaurant Fires*

Incendiary (Suspicious)		32.3%
Igniting flammable liquids	21.3%	
Igniting papers or trash	4.7	
Igniting other or unknown materials	6.3	
Electrical Causes		22.7
Faulty wiring	13.4	
Electrical appliances (except cooking and heating)	9.3	
Cooking		15.8
Igniting grease or fat not in fryers or ducts	6.3	
Involving deep-fat fryers	5.5	
Involving gas	2.4	
Other	1.6	
Smoking		14.2
Igniting paper or trash	11.0	
Igniting furnishings	3.2	
Exhaust Ducts		7.1
Ignition of grease in duct	6.3	
Other	0.8	
Heating Equipment		6.3
Other Causes		<u>1.6</u>
TOTAL		100.0%

Table 4.13 and 4.14 show when and where the fires occur.

*Table 4.13. Operating Status of Restaurants When Fires Occurred*

Open for business	20.0%
Closed, staff present	8.7
Closed, no one known to be present	<u>71.3</u>
	100.0%

*Table 4.14. Place of Origin of Restaurant Fires*

Kitchen	30.4%
Dining Area	14.8
Basement or Heater Room	13.0
Storage Area	9.6
Concealed Space	9.6
Rest Rooms	1.7
Other Areas	<u>20.9</u>
	100.0%

spread 0-25) in all exit paths, Class B (Flame spread up to 75) or Class C (Flame spread up to 200) in dining areas. Drapes, curtains and other decorative textiles are required to be inherently non-combustible or flame retardant treated; flammability of textiles is covered in Section 4.2.4, and in more detail in Volume 1 – State of the Art: Materials, Chapter 3. If better materials are available, it is not clear why the codes consider Class C finish materials acceptable in these high occupancy applications.

### **Exit Hardware**

Security is an important consideration for the property owner. Unfortunately, security safeguards, such as locked doors, barred windows, minimum number of available exits and unbreakable glazing, are not always compatible with fire safety. According to the NFPA Life Safety Code, doors must have no lock or latch; they may be equipped with panic hardware. While the need for security measures is real, compatible measures should be possible.

### **Occupants and Contents**

Restaurants have a high density occupant load; typically codes require a minimum of 3 sq. ft. per person in waiting areas, 7 sq. ft. per person in dance halls and 15 sq. ft. per person in dining areas. These establishments are often fully occupied while in partial darkness. The high density, clutter of tables and chairs, darkness and unfamiliarity with the facility are conducive to panic during a fire emergency.

Nightclubs frequently violate the requirement for proper access to exists. Regulation of table and chair layouts is important and should be enforced.

### **Cooking Equipment**

The danger of fire in cooking areas can be reduced by adhering to the standards of NFPA No. 96, dealing with the removal of grease-laden vapors. Grease flue fires can be prevented by requiring appropriate separation from combustibles, use of sufficiently heavy gauge duct materials and scrupulous cleanliness around and inside hood and ducts. Built-in extinguishing systems are highly desirable.

Tablesides cooking, flame cooking and flaming sword devices have been a contributing cause of fires and should be discouraged.

### **Fire Reports**

The following are abstracts of actual fire reports. These reports highlight how failure to follow the design guidelines presented above, failure to provide protective systems, and improper use of natural and synthetic materials contributed to the catastrophies.

Lisle, III., 3/16/76 (Fire Journal, Mar. 1977)

A steak house was located in a one story wood building with brick and wood



## MATERIALS

exterior. An explosion at 4:30 a.m. in the dining room ignited carpeting, booths, and decorations. The alarm was delayed 30 min. Sprinklers only in the basement, below the fire, proved ineffective. The loss was \$448,000.

Framingham, Mass., 8/2/76 (Fire Journal, Mar. 1977).

A restaurant functioned in a two story non-combustible building. The water-fire-operated alarm was discovered at 12:08 a.m. Six automatic sprinkler heads had operated and extinguished the fire with little damage. The fire had been caused by arson; a plastic container of gasoline had been placed on an operating hot plate.

New York, N.Y., 2/24/76 (Lathrop 1976)

A nightclub was on the first floor of two adjacent five-story buildings of ordinary construction (wood flooring, steel beams, and masonry walls). Apartments were located above the club. The decor included clear plastic columns, decorative fabrics, reflective walls and plastic trees. There were no emergency lights, sprinklers, smoke detectors or evacuation alarms in the club. There were sprinklers in the entrance to the apartments and in the basement. The fire had its origin in an electrical distribution box. Smoke was noticed at 1:30 a.m., but the fire was not observed until stage drapes flared up at 2:00 a.m. The lighting failed, smoke thickened rapidly, and patrons delayed in the coat room for their belongings. Some took refuge in the ladies' room. There were seven deaths due to smoke poisoning. The fatal errors were a lack of leadership by the staff in conducting the evacuation, lack of realization of the threat of the toxicity of combustion products, in addition to the shortcomings of the facilities.

Montreal, 9/1/72 (Watrous 1973)

Lounges were on both the first and second floors of a two story building. The building (built in 1910) had unprotected steel columns, wood joists and floors, and brick and masonry exterior walls. The walls were covered with wood paneling, the floors with rubber tiles, the ceilings were made of acoustical tile on the first floor and low density pressed wood strips on the second floor. The chairs were wood and metal, padded, vinyl covered. Draperies were hung at the metal framed windows. There were no sprinklers, no emergency lighting. The fire was started by gasoline at the foot of the open stairs to the second floor. The egress path through the kitchen to the rear exit was inadequate. A central stairway led many of the occupants into a locked doorway trap. Panic ensued and 37 died.

Alabama, 2/29/67 (Juilbrat and Gaudet 1967)

A restaurant in a modern penthouse addition to a 10-story apartment house had only one stairway exit adjacent to the elevators, although each of the other floors of the building had two exits. Fire near the exit fed on combustible interior finish materials. The patrons were late in realizing the danger; they were barred by fire from the exit; 25 were killed.

Hong Kong, 10/30/71 (Stone 1973)

The Jumbo Restaurant on a floating steel pontoon was under construction and



nearly completed. It had three steel decks, open end balconies, and elaborate Chinese-style pagoda decor. It contained dining areas (1056 seat capacity), bars, dance hall, stage, machinery room, storage areas, and an aquarium. The entire internal steel structure had been covered with plywood on 1" X 3" battens, leaving hollow spaces to the steel of 4 to 18 inches. Ceilings were plywood with emulsion paint and PVC trim strips. For some decks the interior finish was painted embossed plastic panel of polyester on fiberglass; this same plastic panel covered almost the entire exterior. Imitation rock archways framing the entrances to the aquarium were formed of fiberglass reinforced polyester resin on wire screening. The fire started when molten metal from an electric welding operation ignited the imitation rock. The fire spread rapidly, fueled by the combustible finishes and decorations, and spread up the open stairways to engulf the entire ship. Thirty four died and the loss was \$9 million.

Would the Jumbo have been safe after completion? The wood paneling and plastic rocks would have had two coats of fire retardant paint, life jackets would have been available and hydrants connected. Still there would have been open stairways, combustible, smoke-generating decorations and finishes, and no sprinkler system.

Floating restaurants present some of the limited egress problems of high rise buildings. As such they should be made of fire resistive construction, including interior finish and decorations. Vertical openings (stair wells, etc.) should be enclosed. Sprinkler systems, detectors, alarms, hose stations should be provided. Compartmentation should be designed. Safe refuge vessels should be provided.

New Orleans, 6/24/73 (Willey 1974).

A cocktail lounge was on the second floor of a three-story, brick, wood-joisted building. Fire was deliberately set on the stairway of the main entrance. Wood paneling, burlap fabric wall covering, paper decorations and carpeted tread in the stairway led the fire up into the lounge. The interior finish in the lounge comprised rayon-fiber-flocked wallpaper on plaster, wood paneling, glass-fiber ceiling and carpet cemented to a wood floor. The fire spread so rapidly that most patrons could not locate the alternate exit, and could not get out the barred windows. Thirty two died.

*Conclusions:*

- Because of the high occupancy density in restaurants and nightclubs there are frequently many casualties in a fire emergency. Patrons are often trapped by the extreme rapidity with which the fire is spread by the interior finish materials and furnishings.
- The frequent violation of well established fire safety principles contributes heavily to the life and property losses in restaurant and club fires.

*Recommendations:*

- Develop better test and criteria to define and select safer interior finish and decorative materials used in large or contiguous surface areas of rooms with high occupancy density.

- Extend the knowledge of fire-safe textiles, developed since imposition of the Federal Standards for Children's Sleepwear, to textile applications for function and decor in restaurants.
- Consider intumescent coatings as a means for reducing the flame spread rate of wood and synthetic polymer interior finishes and furnishings already in place.
- Find means to enforce fire safety code principles. Keep such codes and standards up-to-date as safer practical materials become available and as better tests for defining safe usage are developed.

#### **4.5.7 Public Assembly Occupancies — Auditoria, Theaters, Exhibition Halls, Arenas, Transportation Terminals, Etc.**

The factors common to these occupancies are: high density of people and relatively slow evacuation in a fire emergency. Most new constructions in these categories are of fire resistant construction and generally sprinkled. Some older structures do not meet the current requirements. Many of the considerations discussed in the previous section on restaurants and nightclubs also apply to theaters and auditoria. The low incidence of fires in theaters and auditoria is probably due to rather strict enforcement of no-smoking regulations in most such occupancies and the general lack of kitchens. In theaters the closely spaced and high volume of foam cushioning has a potential for a very rapidly spreading and disastrous fire.

In exhibition halls, arenas, etc. the large open spaces and relatively high ceilings make fire growth from contents less of a problem. However, some poor designs and improper use of materials have led to tragic and spectacular fires. The U.S. pavilion at the Montreal Exposition was a large geodesic type dome made with acrylic panels. A workman's torch ignited one of the panels and in a matter of minutes the entire structure was involved. Fortunately it was unoccupied at the time and there was no loss of life. The McCormack Place fire of 1967 is a classic example of a non-combustible but not fire-protected steel structure. An electrical malfunction caused ignition in this 350' X 1130' exhibition hall during an exhibition. The fire load was not excessive (less than 10 lbs/sq ft) but there was a large surface area, rapid conflagration, and the heat from the fire caused collapse of the roof.

As described under 4.3.1.6 the use of air-supported structures for enclosing large areas is growing rapidly. "Tennis bubbles" have become an increasingly familiar sight. The Pontiac Silverdome is roofed with such a supported fabric structure and some predict that all stadia roofs of the future will be air supported. Air-supported structures for exhibit halls and traveling shows could be the modern version of the "big tents." Without consideration being given to fire safety the fire hazards could be comparable.

#### **Polymeric Materials Usage**

The major contributions of polymeric materials to the fire threat are:

- Seating — from wood benches to plush polyurethane foam seats with a wide variety of combinations of wood, plastic and metal in between. Polyurethane and latex rubber foam seating supported a large fire in the BOAC terminal, Kennedy Airport, New York (Schafran 1974).
- Draperies — for decoration, sound control and screening. Additional hazard arises from their vertical position, and their relatively large area.
- Temporary partitions — especially in exhibition halls. Such partitions, frequently of lightweight and combustible materials, could account for relatively rapid fire spread through a large hall. The partitions might be wood, foam composites, draperies, paper on wood frames, etc. Temporary thin plywood partitions are often used in airport passageways during construction. These "tunnels" with low ceiling, carpeting over plywood, and smokers "lighting up" as they exit from flights are a hazard with a potential for rapid fire spread.
- Decorations — In addition to draperies, various other plastic decorations are frequently used. These may be relatively large surface area items of lightweight or structural foam, large vacuum formed shapes, lighted panels or signs, manikins, scenery, etc.
- Contents — particularly with exhibition halls, the contents cover a wide range of hazards and can be quite varied. For example, auto shows, home shows, hobby shows, recreation vehicles, boats, etc. present significant hazards.

*Conclusions:*

- The hazard of serious fire in public assembly occupancies is very variable but can be quite high in many cases.
- New and innovative designs are often used for some of these occupancies disregarding fire safety.
- Each structure, its use and functions, has to be analyzed on an individual basis for fire safety.

*Recommendations:*

Require detailed fire safety analyses of the system including materials, design, use, detection, suppression and communication systems, etc. employing a variety of realistic scenarios.

#### 4.5.8 Educational Occupancies

Educational centers include schools, universities, colleges and academies. These can be part-time facilities such as nursery schools where the students are preschool age. The occupants are awake and alert. They can easily recognize the many initial warnings of a fire and are capable of rapid egress. Frequent and unannounced fire drills take place, thereby providing established routines and better organized departures in case of an actual conflagration.

The materials of construction and design of educational institutions have improved with time and help minimize fire risks to life. The ability to confine a fire

## MATERIALS

within a restricted area, thus facilitating evacuation, is found in the more modern structures. One fire has been cited, however, in which a relatively new, modern, noncombustible building had corridor ceilings that contained combustible materials that limited egress via the corridors.

Modern elementary schools have relatively few risks. On the other hand, junior and senior high schools have facilities such as laboratories and shops; these increase the risk. Codes generally require that shops, laboratories, food preparation centers, storage rooms, etc., be separated from other school areas by construction having a fire rating of 1 hr. Stages require a noncombustible separation with a fire resistance of 2 hours.

Colleges and universities encompass a large variety of facilities including dormitories. Fire drills are rare. Therefore, the approach to fire safety is dictated by what is required for each different type of occupancy.

Flammable materials in an educational institution range widely from wooden or plastic seats to the very large volume of books and papers required by students and faculty.

Interestingly, vandalism is the largest single cause of fires in school. This is deduced from the fact that most of the fires occur in the middle of the night, on weekends, or during vacations.

Table 4.15 lists the causes of 155 school fires which were reported to the National Fire Protection Association in 1971 and 1972.

*Table 4.15. Causes of School Fires 1971-1972*

	All School Fires
Incendiary — all types	76.1
Faulty and misused equipment	15.8%
All other known causes	8.1%

In most of the instances the buildings lacked sprinkling equipment and some even did not have an automatic fire detector whose signal will alert the fire department.

Proper design of educational buildings, considering containment of fire, ease of rapid egress, and automatic sprinkler systems, provide the most effective safeguards against loss of life and property.

### *Conclusions:*

Vandalism (occurring principally after school hours) is a major source of fires in elementary, intermediate and high school buildings.

Universities are composed of essentially all types of buildings (dormitories, auditoria, stores, classrooms, dwellings, hospitals, etc.). Fire hazards of each of these types of occupancies exist.

## BUILDINGS

*Table 4.16. Where School Fires Start*

	All School Fires
Classroom	25.4%
Closet, Storage Room	17.0
Office	11.0
Auditorium, Stage, Dressing Rooms	10.1
Basement, Furnace, Utility Room	6.8
Library	5.1
Hallway	5.1
Shops, Labs	5.0
All Other Areas	14.5
Total	100.0%

*Table 4.17. Details of School Fire Ignition Sources*

	All School Fires
Incendiary — All Types	76.1%
Books and Papers	33.7
Unknown Agents	16.3
Flammable Liquids	15.2
Furniture	4.4
Other Materials	6.5
Faulty and Misused Equipment	15.8%
Electrical Wiring	6.5
Electrical Appliances	1.1
Heating Equipment	4.4
Cooking Equipment	2.7
Other	1.1
All Other Known Causes	8.1%

The most effective safeguard against loss of life and property results from the proper design of educational buildings including containment of fire, ease of egress, coupled with automatic sprinkler systems.

*Recommendations:*

Based on technologic developments maintain a continuing updating of codes and regulations to improve the fire safety of educational buildings.

### 4.5.9 Industrial

Industrial building structures could be any of the types described in Section 4.3.1, from the old heavy-timber construction to innovative air or cable-supported "bubble" construction. Most industrial buildings are fire-resistive or non-com-

## MATERIALS

bustible/limited combustible constructions; but, many old small industrial buildings, particularly remodeled ones, are of ordinary or even wood frame construction. A major hazard of the non-combustible/limited combustible construction is structural collapse of unprotected steel in the presence of intense fires.

Industrial occupancies of buildings are too varied to be covered in detail here. We note some general uses of polymers and potential fire safety problems created by the use of polymers. Not included here are the special fire problems of the manufacture, compounding, fabrication and storage of polymeric materials.

Generally in industrial occupancies, in contrast to residential and some commercial occupancies, safety procedures, controls, detection, response and extinguishment capabilities are at a more effective level. In most cases the fire hazards introduced by materials usages are recognized and appropriate steps taken to minimize risks. However, there have been some glaring oversights and errors made in industrial use of polymeric materials.

Improper use of foams or lack of appreciation of the possible hazard of their use probably presents the greatest potential fire hazard from polymeric materials in industrial buildings. Foam uses include building insulation, pipe and tankage insulation, refrigerated area insulation, movie and television set construction, and acoustic applications.

The foams used vary from very flammable flexible polyurethanes and polystyrene foams to more fire resistant materials like phenolic and urea-formaldehyde foams. In spite of the increased fire hazard of exposed foams, many such installations are in existence. The energy crisis and pressures for better insulation have increased the improper and unsafe use of such foams. An example is the "do-it-yourself" quick-fix application of foamed sheet to the inside of buildings.

There have been a number of fatalities from insulation fires in refrigerated storage areas. Ignition is usually caused by electrical malfunctions or workers with torches or other ignition sources.

The MGM movie-set fire in 1974 (Lathrop 1974), is a classic example of the lack of appreciation of the potential hazard from the use of large volumes of exposed flammable foam.

Polymeric materials have replaced metal in many industrial uses to overcome corrosion problems. These include tankage, piping, fume hoods and ducting. Generally employed are glass-reinforced polyester, reinforced epoxies, rigid polyvinyl chloride and polyolefins. Flammability can vary from high (polyolefins) to low (polyvinyl chloride). Fire hazard is also very dependent on the specific uses, environments, procedures and regulations, detection and extinguishment capabilities.

Reinforced polyester, acrylic ABS, and other polymeric panels are often used for curtain walls particularly in a corrosive environment. These, due to vertical orientation, can be a means of rapid fire spread.

Cable insulation, particularly where there are large groups of insulated con-

ductors in vertical chases, can be a means of fire spread as well as extensive damage due to disruption of service. The telephone exchange fire in New York City (Lathrop 1975) is a recent outstanding example (see Section 4.3.3.1).

Synthetic polymers are replacing wood in a number of industrial applications. Structural foam (usually polyolefin) pallets have been found to be very durable and cost effective in many areas. Structural foam bins, racks and similar applications are increasing. The fire safety of such materials varies with a wide variety of factors and these factors must be carefully evaluated when making a material choice.

*Conclusions:*

The use of polymeric materials in industrial equipment, tankage, piping, ducting, pallets, partitions, siding, roofing, insulation (electrical, thermal acoustical) etc. will continue to expand.

Fire hazards introduced by use of such materials varies widely.

*Recommendations:*

Encourage or require detailed fire safety analyses of total systems considering materials, design, use, ignition sources, detection, suppression systems, etc. with consideration of a variety of scenarios. Require this in industrial applications where large numbers of people are involved either directly in the plant or indirectly by loss of function of the plant (telephone exchanges, power plants, etc.).

Promote development and dissemination of fire safety information at materials and sub-system distribution level so that the small individual users with less access to advanced technology can give consideration to fire safety in their uses and purchases.

**References**

- Anderson, E. V., "Year of Recovery for Carpet Fibers," in: C. & E.N., pp. 8-10, 26 January 1976.
- Anon "Fire Destroys Worlds Fair Pavilion," *Engr. News, Record* May 27, 1976, p. 11.
- Anon, British Research Establishment News 38, p. 10 (Jan. 1976).
- Anon. - *Chem. Eng.*, p. 73, 21 June 1976.
- Baldwin, N. C., Society of Plastics Engineers, 33rd Annual Technology Conference, Atlanta, Ga., May 1975.
- Balkowski, D., "The Protection of Exterior Thermal Insulating Finishes" from *Kunststoffe Im Bau* Vol. 12 Strassenbau, Chemie in Technik Verlagsgesellschaft m.b.H 69 Heidelberg.
- Benjamin, I. A. and Adams, C. H., "The Flooring Radiant Panel Test and Proposed Criteria," in: *Fire Journal*, pp. 63-70, March 1976.
- Benjamin, I. A., and Parker, W. J., "Fire Spread Potential of ABS Plastic Plumbing," *Fire Technology*, Vol. 8, No. 2, pp. 104-119, May 1972.
- Breitenbach, J.; Huber, H. and Kuhn, H., "Plastics in Furniture Construction," *Kunststoffe* 64, pp. 590-600, 1974.
- Christian, W. J., "The Effect of Structural Characteristics on Dwelling Fire Fatality," *Fire Journal*, Vol. 68, No. 1, pp. 22-28, January 1974.
- Clark, E. S., Jr., "Fire Retardant Coatings," *Construction Specifier*, pp. 21-26, May 1975.
- Cook, J. A., "VA Hospital Building System," *The Construction Specifier*, pp. 36-42, May 1975.
- Damant, G. H., "Cigarette Induced Smoldering of Flexible Polyurethane Foams," *State of*



## MATERIALS

- California, Department of Consumer Affairs, Laboratory Report No. SP-75-2, February, 1975.
- Damant, G. H., "Flammability Aspects of Upholstered Furniture," State of California, Department of Consumer Affairs, Laboratory Report No. SP-76-1, January 1976.
- Davies, R. L. and Petty, D. J., "Building Elements," The Architectural Press, London, p. 178, 76, 1966.
- Davies, R. M., Ed., "Plastics in Building Construction," Blackie and Sons, Ltd., London, 1965.
- Day, M.; Mitton, M. T. and Wiles, D. M., "Carpet Flammability: A Pill Ignition Test Procedure Employing Auxiliary Radiant Heating," in: *J. Fire & Flammability*, pp. 268-288, Vol. 5, October 1974.
- Degenkolb, J. G., "Life Safety in Hospitals and Nursing Homes," *Construction Specifier*, pp. 19-29, July 1976.
- Denyes, W. and Quintiere, J., "Experimental and Analytical Studies of Floor Covering Flammability with a Model Corridor," NBSIR 73-199, p. 1-105, May 1973.
- Dietz, A. G. H., "Plastics for Architects and Builders," The M.I.T. Press, Cambridge, 1969.
- Eickner H. W. and Peters, D. C., "Surface Flammability of Various Decorative and Fire-Retardant Coatings for Wood as Evaluated in FPL 8-Foot Tunnel Furnace," *J. of Paint Tech. & Engn., Official Digest*, pp. 800-812, August 1973.
- Engineering News Record 192, p. 137 (April 30, 1974).
- Fabris, H. J. and Sommer, J. G., "Flame Retardation of Natural and Synthetic Rubber," in "Flame Retardancy of Polymeric Materials," Karyla and Pupa eds., Vol. I. Dekker, New York (1973).
- Federal Trade Commission, "Cellular Plastics Products, Disclosure of Combustion Characteristics in Marketing and Certification" *Federal Register*, Vol. 40 No. 142, July 23, 1975, p. 30842.
- Federal Register, "Standard for the Surface Flammability of Carpets and Rugs," 35 (74), 16 April 1970.
- Fire Prevention Handbook, 14th Edition, National Fire Protection Assoc., Boston, 1976.
- "Flame Retardancy of Polymeric Materials," Vol. I, Dekker, New York, 1973.
- Fung, F. C. W.; Suchomel, M. R. and Oglesby, P. L., "The NBS Program on Corridor Fires," in: *Designing Buildings for Fire Safety*, NFPA Pub. No. SPP-24, 30-37.
- (a) Gross, D. and Loftus, J. J., "Flame Spread Properties of Buildings Finish Materials," *ASTM Bulletin No. 230*, pp. 56-60, May 1958.
- (b) Gross, D. and Loftus, J. J., "Surface Flammability of Fire Retardant and Conventional Paint Assemblies," *Fire Research Abstracts and Reviews*, Vol. 3, No. 3, pp. 151-157 September 1961.
- Harris, M. J., *Handbook of Textile Fibers*, 1954.
- Hartzell, L. G., "Development of a Radiant Panel Test for Flooring Materials," NBSIR 74-495, 1-74, May 1974.
- Hecker, K. C., *Rubber World*, 159 (3), 59, 1968.
- Hedlund, C. F., "Grouped Combustible Wires and Cables," *Fire Journal*, March 1966.
- Hillenbrand, L. J. and Wray, J. A., "Space Age Contribution to Residential Fire Safety," *Fire Journal*, 68, March 1974.
- Horbach, E., U.S. Patent 3,389,518 (1968).
- Howarth, J. T.; Lindstrom, R. S.; Sheth, S. C. and Sidman, K. R., "Flame Retardant Additives," *Plastics World*, pp. 64-74, March 1973.
- Hug, D. P., "Polypropylene Foams," *Modern Plastics Encyclopedia*, p. 129, 1974-1975.
- Huggett, C., "Carpet Flammability and the NBS Corridor Fire Program," in: *ASTM Standardization News*, pp. 16-20, May 1973.
- Huntington, W. C., "Building Construction, 3rd Edition," John Wiley and Sons, New York, p. 562 ff.
- Huntington, W. C., "Building Construction,, Third Edition," John Wiley and Sons, New York 1963, p. 524 ff.



## BUILDINGS

- Ivett, R. W., *Polypropylene Fibers-Properties and Applications*, Symposium on Polypropylene Fibers, Southern Research Institute, 1964.
- Jacobs, D. M., "Investigation-Re: Household Insulation Potential for Substantial Hazard," Letter to W. T. Lang, DEN-AO CPSC, February 13, 1976.
- Jones, R., CPSC Petition No. CP-77-1 February 22, 1977.
- Juillierat, E. E. and Gaudet, R. E., *Fire Journal*, 61, p. 5, May 1967.
- Kaswell, E. R., *Wellington Sears Handbook of Industrial Textiles*, 1963.
- Kirshenbaum, G. S., *Modern Plastics Encyclopedia*, p. 65, 1976-77.
- Lathrop, J. K., *Fire Journal*, 68 (6) p. 16, November 1974.
- Lathrop, J. K., *Fire Journal*, 70, pp. 50, 51, 71, November 1976.
- Lathrop, J. K., *Fire Journal*, 70, pp. 7-13, Nov. 1976.
- Lathrop, J. K., "Telephone Exchange Fire," *Fire Journal*, July 1975.
- Lathrop, J. K., "The Summerland Fire " *Fire Journal*, pp. 5-10, March 1975.
- Lathrop, J. K., "World Trade Center Fire " *Fire Journal*, July 1975.
- Martino, R., *Modern Plastics*, pp. 48-50, February 1976.
- Maslow, P., "Chemical Materials for Construction," Structures Publication Co., Farmington, Michigan, p. 398 ff, 1974.
- McKinnon, G. P. (editor), *Fire Protection Handbook*, 14th edition, National Fire Protection Association #FPH1476, Sec. 3, Chap. 1, 1975.
- McKinnon, G. P. (editor) (b) *Fire Protection Handbook*, 14th edition, etc. Sect. 6, Chap. 5 p. 37 (c) Sect. 6, Chap. 4, p. 18.
- Meyers & Long - (Coatings book).
- Modern Plastics*, 49, p. 62 (September, 1972).
- Modern Plastics*, 50, p. 38 (July, 1973).
- Modern Plastics*, 50, p. 82 (October, 1973).
- Modern Plastics*, 52, p. 44 (January 1975).
- Modern Plastics*, 54, p. 43, January 1976.
- Modern Plastics*, 52, (production data), January 1975.
- Monaghan, J. F., *Plastics in Building Construction*, #4, p. 20, April 1975.
- Moore, L. D. and Vickers, A. K., "A Survey of Fire Accidents Involving Curtains and Draperies," National Bureau of Standards, Final Report No. NBSIR-75-902, December 1975.
- National Fire Protection Association Bulletin NFPA No. FR73-1, *A Study of School Fires*, 1973.
- NFPA-101, Life Safety Code, pp. 101-127, 1976.
- Osmon, H., private communication.
- Ottosan, J., *Fire Journal*, 67, pp. 89-91, January 1973.
- Palmer, K. N. and Taylor, W., "Fire Hazards of Plastics in Furniture and Furnishings," Building Research Establishment, Borehamwood, England, Reports Nos. CP 18/74, CP 3/75, CP 21/76.
- Parker, W. J., "Fire Endurance Tests on Walls and Plumbing Chases Containing Metallic or Nonmetallic DW & V Systems," National Bureau of Standards, NBSIR 74-449, November 1973.
- Pearce, E. M. 1973.
- Prane, J. W., "Plastics in Roofing," in *Plastics in Building*, I. Skeist, Editor, Reinhold Publishing Corp., New York, pp. 359 ff, 1966.
- Quintiere, J. and Huggett, C., "An Evaluation of Flame Spread Test Methods for Floor Covering Materials " National Bureau of Standards Special Publication 411, 59-89, November 1974.
- Sarvetnick, H. A., *Polyvinyl Chloride, Reinhold Plastics Application Series*; Reinhold Publishing Co., New York, p. 219, 1969.
- Schafran, E., *Fire Journal*, pp. 36-39, March 1974.
- Skeist, I., Ed., "Plastics in Building," Reinhold Publishing Corp., New York, 1966.

## MATERIALS

- SPI *Urethane Plastics*, Report from Urethane Safety Group, The Society of Plastics Industry, 250 Park Avenue, New York, New York, 1974.
- Rossiter, W. J.; Mathey, R. G.; Burch, D. M. and Pierce, E. T., "Urea-Formaldehyde Based Foam Insulation," NBS Technical Note 946, July 1977.
- Stoddard, J. W.; Pickett, O. A.; Cicero, C. J. and Saunders, J. H., "Flame-Retarded Nylon Carpets," *Textile Res. Journal*, pp. 474-483, June 1975.
- Stone, W. R., *Fire Journal* 67, pp. 55-59, July 1973.
- Time*, November 17, 1975, p. 84.
- Tu, K. M. and Davis, S., "Flame Spread of Carpet Systems Involved in Room Fires," NBSIR pp. 67-1013, 1976.
- U.S. Department of Commerce, "Construction Review," 21, No. 4, May, 1975, pp. 18-25.
- U.S. Department of Commerce, "Statistical Abstract of the United States, 1974."
- Waksman, D. and Ferguson, J. B., *Fire Technology*, 10, No. 3, pp. 211-20, August 1974.
- Watrous, L. D., *Fire Journal*, 66, pp. 5-8, Jan. 1972.
- Watrous, L. D., *Fire Journal*, 67, pp. 6-9, January 1973.
- Willey, A. E., *Fire Journal*, 68, January 1974.
- Williamson, R. B., Tutorial presentation to committee (1976).
- Wood, A. S., "Bathroom 'Also-Ran' Now Sets the Pace," *Modern Plastics*, pp. 40-43, March 1975.
- Wood, A. S., *Modern Plastics*, pp. 64-65, June 1974.
- Wyly, R. S., et al., "Review of Standards and Other Information on Thermo Plastic Piping in Residential Plumbing," NBS Building Science Series 68, May 1975.

## CHAPTER 5

### TEST METHODS AND STANDARDS

#### 5.1 Introduction

The field of fire hazard testing of materials is in a state of ferment at the present time. The relevance of old, well established test methods is being questioned and new concepts of performance testing are being discussed. This situation is due largely to two factors: the influx of new materials and products, principally based on synthetic polymers, into modern building design and an increased emphasis on life safety in fire regulations.

Until about 10 years ago the emphasis of fire safety regulations, fire test methods, and fire research was on the protection of property. The test methods used were developed on the experience that test designers were able to relate to the specific problem at that time. Experience was mainly limited to fires involving cellulosic materials. Primarily these tests ranked materials relative to a given cellulosic standard (e.g., red oak). The experience of the test designers essentially led to a measure of the hazard of these materials in the end-use situation. Thus, a few well established tests served to characterize the behavior of new applications and new construction techniques. In today's era of synthetic materials the tests that were formerly adequate may no longer be appropriate or valid today.

With the recognition that the human cost of fires, in terms of deaths and injuries, might equal or exceed the direct property loss, and with increased emphasis on the safety of the public, the main thrust of fire safety has shifted from the protection of structures and property to the protection of building interiors and their occupants. This has focused attention on the fire properties of a new class of hazard: the many consumer products, materials, and furnishings that create the environments of modern structure interiors. These provide numerous opportunities for ignition, rapid fire growth, and the spread of smoke and toxic gases. They pose a threat to human safety out of proportion to their contribution to structural damage and property loss in most fires.

Many of these new products are made of polymeric materials. A great variety of new materials whose widely differing fire performance properties are not known or not widely recognized have been introduced. Fire performance tests designed to evaluate the structural fire performance of traditional materials were inappropriate for these new materials and applications. As a result, there has been a proliferation of new small scale test methods. Most of these methods originated as *ad hoc* tests in development laboratories; the tests were designed to permit the convenient comparison of experimental material formulations. Their relevance to the performance of products under use conditions was seldom a factor in test development. A few of these tests have achieved recognition as standard test methods by virtue of their endorsement by ASTM, NFPA, Underwriters' Laboratories and other organizations.

These small-scale tests are attractive since they are economical to conduct in comparison to tests on full-scale replications of rooms, corridors, buildings, etc. The major problem, however, is that there is a general lack of correlation between small-scale laboratory test results and real-life large-scale fire behavior.

The action of the Federal Trade Commission against the cellular plastics industry (FTC 1975) triggered a massive reexamination of the ability of existing fire test methods to predict the performance of materials, products, and systems in fires. While the FTC action provided the impetus, recognition of the problem had been building up in the fire research community for a number of years.

In this chapter, current test methods and standards employed to measure the flammability characteristics of materials used in buildings will be listed and discussed. In particular, their usefulness to evaluate synthetic polymeric materials will be addressed.

### 5.2 Test Methods

The tests described and listed in Table 5.1 are significant or widely used in the evaluation of fire performance of materials used in buildings. It is not feasible to give a detailed description of each test here; however, each test is referenced so that a full description can be easily obtained.

### 5.3 Standards and Codes

#### 5.3.1 Fire Safety Provisions in Building Codes

Building construction codes and standards are the responsibility of local governments, which may be a city, county or state. Local governments may develop their own codes or they may adopt a model code published by a code making organization. There are four such codes and organizations:

- Basic Building Code, published by the Building Officials and Code Administrators International, Inc., Chicago, Illinois.
- National Building Code, published by the American Insurance Association, New York, New York.
- Standard Building Code, published by the Southern Building Code Congress International, Inc., Birmingham, Alabama.
- Uniform Building Code, published by the International Conference of Building Officials, Whittier, California.

Generally, each of these model codes is used in a specific geographic area of the country. But any city, county or state may adopt any code. Local governments may adopt a model code in whole or in part, or may make regional exceptions or modifications. The basic building code covers the fire, life and structural safety aspects of buildings and related structures. Some model code organizations publish other related codes such as:

- Mechanical codes covering installation and maintenance of heating, ventilating, cooling and refrigeration systems.

BUILDINGS

Table 5.1. Fire Tests for Building Materials, Components and Furnishings

Test Method	Sample Size	Application	Test Results
<b>1. Ignition Tests</b>			
ASTM D-1929	3 ± 0.5g	all organic materials	measures flash-ignition temperature in a hot-convective air furnace
DOC FF-1-70 (ASTM D-2859)	230 x 230 mm	textile floor coverings, i.e., carpets	measures the char length from a methenamine tablet ignition flame; specimen rated resistant to flammability if char does not extend beyond 178 mm from ignition point; passage of test reduces probability of carpet ignition
DOC FF-4-72	production unit	mattresses	measures char lengths from 18 cigarette ignition sources placed on mattress test surface; mattress passes test if char length on surface is not more than 5.1 cm in any direction from nearest cigarette
Proposed standard for upholstered furniture (PFF 6-76)	varies depending on surface location to be tested; mockup assembly or finished upholstered furniture item		
ASTM E-136	38 mm x 51 mm x 38 mm	all organic and inorganic materials	materials reported as noncombustible if meet temperature rise, flaming and weight loss criteria
<b>2. Flame Spread Tests</b>			
ASTM E-84 Tunnel Test	20 in x 25 ft x actual thickness	interior finish materials (e.g. paneling, ceiling tile etc.) sheathing, thermal/acoustic insulation	primarily measures surface flame spread; values range from 0 for for "non-combustibles" such as asbestos cement board to 100 for red oak and higher for other materials; also measures smoke generation and fuel contribution
ASTM E-162 Radiant Panel	6 in x 18 in x 1 in max. thickness	generally used as a screening test; may be used for applications of E-84	measures flame spread factor and temperature rise; values originally intended to be similar to ASTM E-84
Floor Radiant Panel Test	100 cm long	floor covering systems installed in building corridors and exitways	measures minimum radiant flux necessary to sustain flame propagation on the flooring surface, acceptance criteria: 0.25 W/cm <sup>2</sup> for residential and commercial occupancies, 0.50 W/cm <sup>2</sup> for institutional

(Continued)

TEST METHODS AND STANDARDS

Table 5.1. Fire Tests for Building Materials, Components and Furnishings (Continued)

Test Method	Sample Size	Application	Test Results
<b>2. Flame Spread Tests (continued)</b>			
ASTM D-635	125 mm x 12.5 mm x supplied thickness	laboratory screening test test of relative flammability of self-supporting plastics in form of bars	measures horizontal burning rate when flame proceeds 100 mm, or time and extent of burning other- wise
ASTM D-1692	150 mm x 12.5 mm x up to 13 mm thick	laboratory screening pro- cedure for rigid or flexible cel- lular plastics roof coverings	measures horizontal rate of burning or extent of burning
ASTM E-108 (UL 790 for limits)	1 m x 1.3 m 1 m x 4.0 m		measures response of roof deck to intermittent flame, measures flame spread distance, and subjects the roof deck to burning brands. Roof covering materials are rated Class A (best), Class B, and Class C de- pending on performance in these tests
UL 94	127 mm x 12.7 mm 152 mm x 50.8	plastic parts in devices and appliances	measures burning rate in the hori- zonal and vertical configurations de- pending on classification. Test essen- tially employs ASTM D-635 and D-1692 for horizontal burning test and ASTM E-162 Radiant Panel Test. Also includes an ig- nition test
UL 44	depends on paragraph	rubber-insu- lated wires and cables	measures burning extent and time, ignition of cotton underneath from dripping
UL 83 (flame test)	approx. 46 cm	thermoplastic insulated wires	measures flame spread and flamm- ing resistance of vertically mounted wire specimen
IEEE 383 (flame test)	multiple cables mounted in a tray 3 in deep x 12 in wide x 8 ft long	Class IE electric cables	cables which propagate the flame and burn the total height of the tray above the flame source fail the test. Cables which self-extin- guish when the flame source is removed or burn out pass the test

(continued)

BUILDINGS

Table 5.1. Fire Tests for Building Materials, Components and Furnishings (Continued)

Test Method	Sample Size	Application	Test Results
<b>2. Flame Spread Tests (continued)</b>			
FM 4922	7.2 m	air and fume handling ducts	to pass the test flaming must not proceed from the ignition fire to other end of the duct, interior duct temperatures are limited to 1000°F during the test and maximum one-minute heat release rate of duct interior must not exceed 200 Btu/ft <sup>2</sup> min
NFPA 701	small-scale test 7 cm x 25 cm; large-scale test 12.7 cm x 2.1 m 0.6 m x 2.1 m	flame resistance textiles and films; used in the interior furnishings of buildings and transport facilities, protective clothing, and for protective outdoor coverings such as tarpaulins and tents	test limits specimen flaming time, vertical flame spread, and flaming of drippings
<b>3. Rate of Heat Release Tests</b>			
ASTM E-84	20 in x 25 ft x actual thickness	interior finish materials (e.g. paneling, ceiling tile etc.) sheathing, thermal/acoustic insulation	reports <i>total</i> heat release, not <i>rate of</i> , and provides information relative to red oak only
NBS Calorimeter	11.4 cm x 15.2 cm	same as ASTM E-84	measure heat release rate as a function of time; typically reports peak, 1-min, 5-min and 10-min averages, for heat release rates
OSU Calorimeter	25.4 cm x 25.4	same as ASTM E-84	same as NBS Calorimeter
FM Calorimeter	4.5 ft x 5 ft x actual thickness	composite roofing assemblies	measures heat release rate as a function of time; roof classification depends on peak rate

(Continued)

TEST METHODS AND STANDARDS

Table 5.1. Fire Tests for Building Materials, Components and Furnishings (Continued)

Test Method	Sample Size	Application	Test Results
<b>4. Tests for Oxygen Requirement</b>			
ASTM D-2863 (LOI)	depends on plastic form e.g. self-supporting 6.5 mm x 3.0 mm x 70–150 mm	various forms of plastics including film and cellular plastic	measures the oxygen index (minimum concentration of oxygen in flowing O <sub>2</sub> /N <sub>2</sub> mixture to just support flaming combustion; also descriptions of charring, dripping, bending, etc.
<b>5. Extinguishment Test Methods – None</b>			
<b>6. Tests for Smoke Evolution</b>			
NFPA 258	3 in x 3 in. x 1 in max. thickness	all organic and inorganic solid materials and assemblies	measures maximum optical smoke density under flaming and smoldering conditions under an external radiant flux of 2.5 W/cm <sup>2</sup>
<b>7. Tests for Toxicity – None</b>			
<b>8. Tests for Fire Endurance</b>			
ASTM E-119	Walls > 100 ft <sup>2</sup> ; Floor/ceiling > 180 ft <sup>2</sup>  Column length > 8 ft Beam/girder length > 12 ft	complete walls; floors/ceilings  individual structural elements (e.g. columns, beams, girders, etc.)	determines ratings in hours. Failure criteria: flame penetration on unexposed face, back surface average (single point) temperature rise > 250° F (>325° F), structural collapse  When applied design loading can no longer be sustained or when steel surface temperature reaches a predetermined level.
ASTM E-152	Full-scale door and frame installations, test assembly > 100 ft <sup>2</sup>	doors	determines ratings in hours; no flame penetration on unexposed face. Door must also remain in place during hose-stream test immediately following fire endurance test
ASTM E-163	Windows and shutters installed; test assembly > 100 ft <sup>2</sup>	windows	must withstand fire endurance test for 45 min. and hose-stream test that follows
<b>9. Full-Scale Fire Tests</b>			
ASTM E-603	8' x 8' x 12', 10 x 10'; with 8' ceiling	rooms (materials, products, systems)	time to flashover, total rate of smoke production, extent of flame spread for a low energy ignition source required to produce flashover

(Continued)



## BUILDINGS

*Table 5.1. Fire Tests for Building Materials, Components and Furnishings (Continued)*

Test Method	Sample Size	Application	Test Results
<b>9. Full-Scale Fire Tests (continued)</b>			
Factory Mutual Building Corner Fire Test	Walls 50' x 24' — 9" 37' — 9 x 24' — 9" Roof/ceiling 20–26 gauge corrugated steel	interior finish materials	material tested is considered acceptable if it does not produce a self-propagating fire within the limits of the structure as evidenced by flaming or material damage
University of California Berkeley—Corner Test	Corner 6' x 6' x 8' high ceiling 6' x 6'	interior finish materials	measures extent of flame travel and damage

*(Concluded)*

- Fire codes covering provisions regulating the storage, use and handling of hazardous substances and processes such as cellulose nitrate motion picture film, cellulose nitrate plastics, explosives and blasting agents, fireworks, transportation pipelines, etc.

None of these codes are intended to stand alone, as each may reference many other codes or standards such as the National Plumbing Code developed by the American Society of Mechanical Engineers and the National Electrical Code sponsored by the National Fire Protection Association (NFPA). There are many standards published by NFPA covering installation of fire protecting equipment, alarm systems, etc. that are referenced by the model codes.

Model code fire safety measures are generally concerned with:

1. Egress regulations based on the number of occupants, their physical condition, and the time required for them to leave a building or reach an area of safe refuge.
2. Provisions to protect structural members, so as to prevent premature collapse. Protection is generally in the form of a noncombustible insulation barrier such as concrete, masonry, plaster or gypsum; duration of protection is measured by a standard fire resistance test. The required time (hours of fire resistance) is based on fire loading, type of occupancy, and height and areas of building. Hospital construction codes require structural members to have a high degree of fire resistance, even though the fire load is low, because of the relative immobility of the people being housed.
3. Provisions to prevent fire and smoke spread by subdividing the building into limited areas through the use of fire resistive walls, floors and ceiling assemblies and doors.
4. Provisions with respect to combustibility, e.g.:
  - a. Combustible buildings (unprotected and protected wood) are limited in area or not permitted for some occupancies such as hospitals and nursing homes.

## TEST METHODS AND STANDARDS

- b. Flame spread of interior surfaces walls, ceiling and floors is limited according to use. For example, a flame spread value of 25–75 (ASTM E 84 Test) is prescribed for public egress routes, 200 for apartments, 75 for patient rooms, etc.
  - c. Smoke generation criteria for interior finishing materials in the model codes attempt to screen the use of the very high smoke producing materials. Normally the limiting criterion is 450 using ASTM E 84; however, some Federal agencies are using 450 with NFPA 258 which is more restrictive.
  - d. Some of the model codes require that the products of combustion of interior finishes be no more toxic than the burning of untreated wood under similar conditions.
5. Provisions for fire detection and alarm systems. These vary as to occupancy. Since about 1974, smoke detectors of the single station type have been required in every newly constructed residential living unit and hotel room, in certain jurisdictions. In 1976, Montgomery County, Maryland, passed a law requiring that a smoke detector be installed in all new and existing dwellings. However, only about 3 percent of living units in this country currently have a smoke detector.

A manual fire alarm system is generally required for schools, hospitals, nursing homes and other occupancies where the buildings are over three stories in height.

Retail stores, office buildings and apartment buildings with floors more than 75 feet above the lowest level of fire department vehicle access are required by some model codes to have a voice alarm system, voice communication system, smoke detectors located in every mechanical equipment room, and in return air systems that serve floors other than the floor on which the exhaust equipment is located. Fire detectors are required in elevator lobbies on each floor of high rise buildings so that they can program elevators to bypass the fire floor and return to the ground floor for fire department manual operation.

6. Requirements for fire extinguishing systems. These vary with occupancy, floor area, and access by the fire department: e.g., they are frequently required in basements or cellars; in place of assembly or educational purposes; in all hospitals, nursing homes, in residential and hotel buildings of more than a specified height. Model code provisions for fire extinguishment capability however are not consistent.
7. Provisions for permitted height and area. These vary with type of occupancies, type of construction (fire resistive, protected noncombustible, noncombustible, heavy timber and wood frame) and requirements for fire extinguishing systems. Generally fire resistive construction is unlimited in area and height.

In the past and to some extent today, development of building code fire safety

provisions has been primarily revision of existing codes based on a catastrophic fire incident, rather than as a result of systematic analysis.

Adoption of improper or unbalanced fire protection provisions in a building code can nullify many of the fire protection endeavors, or it may severely economically penalize new and existing construction without providing commensurate fire safety. A means of checks and balances is needed to assure that fire protection and safety measures in building codes are technically sound and economically feasible.

### 5.3.2 Specific Standards and Code Criteria Relating to Polymeric Materials

The following typifies model code requirements concerning fire safety standards for polymeric materials:

- Foamed and solid plastics are required to be no more toxic than those of untreated wood when burned under similar conditions.
- Flame spread limit for plastic foam is 75 and smoke 450, tested in accordance with ASTM E 84.
- Flame spread limit for solid plastic is 225 and smoke 450, tested in accordance with ASTM E 84. Some codes allow an optional smoke density limit of 75 tested in the thickness intended for use by ASTM D2843, "Density of Smoke from Burning Plastics."
- Plastic foam insulation is permitted in the cavity of masonry walls, and on or in frame walls or ceilings, only when protected from the interior by a thermal barrier of ½ inch thick gypsum board or other material having a rating of not less than 15 minutes as determined by the ASTM E 119 fire test.
- Ordinary roof covering is allowed over foamed plastic insulation when the foam is separated from the interior of the building by ½ inch plywood sheathing bonded with exterior glue. The codes do not cover the use of exterior wall foamed plastic sheathing other than as siding backer board. Foamed plastic siding backer board is limited to 3/8 inch in thickness, must not produce more than 2,000 Btu per square foot, and must be separated from the interior of the building by not less than 2 inches of mineral wool insulation.
- Interior foamed plastic trim, covering not more than 10 percent of the wall or ceiling area, is permitted, provided such trim has a density of not less than 20 pounds per cubic foot, has a maximum thickness of ½ inch, has a maximum width of 4 inches, and has a flame spread rating no greater than 75.
- Use of plastic window glazing is permitted in buildings that are equipped with an automatic fire extinguishing system. The glazing is limited in area and size; vertical separation is specified between floors. Plastic glazing is not permitted in places of assembly; nor in places used for storage and handling of hazardous and highly flammable or explosive materials.
- Exterior plastic veneer which meets the requirements for noncombustibility (a structural base of noncombustible material with a surfacing material, not over 1/8 inch thick, which has a flame spread of 50 or less) is unlimited as to height

and length of veneered area. Other plastic exterior veneers are limited to 35 feet in height, an area of 200 square feet, and separation of a minimum of 4 feet.

- The codes cover other uses of plastic for such components as skylights, plastic light diffusers in ceilings, electrical lighting fixtures, awnings, patio covers, greenhouses and canopies.

### 5.3.3 Mobile Home Standards

As of June 15, 1976, mobile home construction was required to meet Federal standards published by the Department of Housing and Urban Development. This was the first Federal mandatory construction code in this country. Mobile home manufacturers lobbied for this standard because of the diverse local and State requirements. (Local and State authorities can not pre-empt the Federal standard). Fire safety in this standard (Mobile Home Construction and Safety Standards) is limited to: egress requirements for two exterior doors located remotely from each other; an egress window-located in each bedroom; a smoke detector located near each bedroom area; flame spread limitation of 200 (by ASTM E-84) for wall and ceiling finishing material to protect furnace and water heater enclosure and cooking unit.

The mobile home standard covers the use of foamed plastics as follows:

- (a) General. Foamed plastic thermal insulating materials shall not be used within the cavity of walls or ceiling or exposed to the interior of the mobile home, unless otherwise specifically approved by HUD, based on accepted tests including full scale room fire testing.
- (b) Specific requirements. Foamed plastic having a flame spread rating of 75 or less may be used as siding backer board or sheathing with a maximum of 3/8-inch thickness when separated from the interior of the mobile home by a minimum of 2-inches of mineral wool insulation or equivalent fire protective material.

## 5.4 Discussion of Test Methods

In this section test methods to measure various aspects of polymer flammability are discussed. In particular, the usefulness of current tests to evaluate the flammability characteristics of synthetic polymeric materials will be addressed. Additional discussion of test methods can be found in Chapter 5 of Volume 2 of this series.

### 5.4.1 Ignition Tests

Ignition of a combustible material is the first stage in any fire. Once the fire is started, ignition delay times of other materials, coupled with flame spread, affects the rate of fire spread and growth. Hence, ignition is crucial to fire prevention and control.

Most polymeric materials will ignite and burn if sufficiently heated in the presence of air or other atmosphere containing sufficient oxygen. Consequently, from the point of view of fire safety, it is desirable to know how long it takes a

particular polymer to ignite, or whether or not it will ignite when exposed to a given oxygen containing environment and a given heating rate.

The ignition of a polymer is an extremely complex process depending on heat and mass transfer, thermal degradation, and chemical reactions. It is generally agreed that for most polymers, flaming ignition occurs in the gas phase above the polymer surface and involves an exothermic reaction between oxygen and the pyrolysis products of the fuel. Hence the degree of air motion or turbulence, as well as access to oxygen, is important. The heat transfer process from the ignition source of the polymeric material, which may be some combination of conduction, convection and radiation heat transfer, will also influence the ignition process.

The thickness and thermal properties of a material are vital in determining the time required to achieve ignition, given a specific heat flux and environmental conditions. The time to ignition for a "thermally thick" specimen (see Section 3.3.3 of Volume 4) is independent of the thickness and is controlled by the "thermal inertia," which is the product of the thermal conductivity and the heat capacity per unit volume. For a "thermally thin" specimen, the time to ignition is proportional to the product of the thickness and the heat capacity per unit volume (fabrics are generally in this category). Whether the specimen behaves in a "thermally thick" or "thermally thin" manner depends not only on the physical thickness, but also on the heating rate, the heating time and the "thermal diffusivity," which is the ratio of thermal conductivity to heat capacity per unit volume.

In the case of a thin flammable material (carpet, paneling, etc.) in thermal contact with an underlying material, the thermal properties of the underlying material can strongly influence the ignitability by the degree to which the underlying material acts as a heat sink.

Configuration and orientation of the polymeric material can also be of great importance. Ignition tends to occur more readily in crevice or fold, at an edge or corner, etc., rather than in the middle of a flat surface.

The complexities of ignition phenomena make it impossible to devise a single test that will determine the ease of ignition of different materials for a variety of end-use situations. It has already been pointed out that ignitability will depend on specimen thickness and geometry, the type and method of application of the ignition source, ventilation and environmental conditions. Consequently, most ignition tests are of limited value. Many of the ignition tests currently employed (e.g., ASTM D-1929, ASTM D-229, UL ignition temperature test, UL hot wire ignition test, etc.), expose a specimen to heated air and measure the temperature (and/or time) required for ignition. This so-called "ignition temperature" is not an intrinsic property of the material, but depends strongly on ventilation rate, test specimen size and obviously on the heating conditions in the test. Yet these "ignition temperatures" are frequently reported, and used to rank materials.

Two recently developed ignition tests, designed to simulate cigarette ignition, have avoided the complexities mentioned above by employing an actual burning

cigarette with materials in the specific application, i.e., as a mattress or as covering and padding for upholstered furniture. Despite the simplicity of the test, once the optimum arrangement and location for placing the ignition source was determined, the results are a good indication of the hazard for these common occurrences. Obviously the test does not simulate fire performance of these materials when exposed to a flaming ignition source.

A similar approach is taken in ASTM D-2859. This test measures the resistance to burning of carpets from a small ignition source, an ignited methenamine tablet; passage of this test indicates a reduced probability of carpet ignition from small ignition sources, e.g. a spark, a burning ember, etc.

There seems to be little current work to develop additional ignition tests for materials used in buildings. In view of the complexities of the ignition phenomena, it would seem that future ignition tests should be directed towards determining whether or not ignition occurs from a given source, e.g., match flame, grease pan kitchen fire, etc., to a given item, e.g., drapes, kitchen cabinets, etc. This approach, determining ignitability in a specific instance, could be based on fire statistics data of the most probable "ignition source — ignited item" combinations and would give an accurate measure of the ease of ignition under the specific circumstances of the test. An alternate approach would be to measure some ignition property, e.g., ignition time, in a carefully controlled experiment. Then, recognizing that the quantity measured is not an intrinsic property of the material, attempt to establish some relationship of this "property" to fire safety in actual situations.

#### **5.4.2 Flame Spread Tests**

Unless a person is in intimate contact with the ignited item, a fire is not apt to do much harm until it has grown by spreading some distance from the point of ignition. The rate of flame (and fire) spread is very important in the history of a fire, because it controls the time, after ignition, until the fire reaches a dangerous size. The "dangerous size" relates to the rate of heat release, to the rate of generation of toxic and smoky products, or to the difficulty of extinguishment. The ability to detect, fight, or escape from the fire depends on the time before the fire reaches a dangerous size and hence, on the spread rate.

The propagation of a flame over a combustible solid is an extremely complex process. A large body of test methods have evolved over the past thirty years designed to measure the rate of flame spread. Many of these tests were developed without allowing for the numerous factors influencing the flame spread rate. Efforts have been largely fragmented and the test methods developed yield results that are generally not consistent and do not adequately reflect behavior in actual fires.

Results from many experimental investigations have been summarized by Friedman (1968) and Magee and McAlevy (1971). They indicate that the flame spread velocity is affected by many physical and chemical parameters such as:

## BUILDINGS

### Physical and geometrical parameters including:

- orientation of surface
- direction of propagation
- thickness of specimen
- specimen size
- surface roughness
- presence of sharp edges or crevices
- initial fuel temperature
- environmental pressure
- flow velocity of environment
- external radiant flux
- humidity

### Chemical parameters including:

- composition of solid
- composition of atmosphere
- composition of fuel pyrolytic products

It is essential that individuals involved with test method development and those responsible for selecting tests to serve as a basis for material specifications recognize how strongly some of these physical and geometrical parameters affect the flame spread rate. For example, vertical flame spread is a continuously accelerating process; for small specimens, the upward flame spread rate is at least an order of magnitude faster than downward vertical or horizontally spread rate. Also, horizontal flame spread over specimens with exposed edges occurs approximately five times as fast as when the edges are not exposed. Raising the initial temperature of polymethylmethacrylate from 25°C to 150°C doubles the horizontal flame spread velocity. Increasing the specimen thickness for "thermally thin" specimens lowers the flame spread rate proportionally; since for "thermally thin" specimens the flame spread velocity varies inversely with the specimen thickness. These examples and others (Magee and McAlevy 1971) show how important an understanding of the factors influencing flame spread is when either developing or selecting an appropriate flame spread test.

Since heat must travel ahead from the flame to the unignited material (possibly augmented by radiation from the surroundings) in order to propagate the flame, certain heat transfer modes must be involved. However, with regard to the flame spread rate, as chemical and physical parameters are varied, changes occur in the magnitude and relative importance of conduction or convection in the gas phase, conduction in the condensed phase, and radiation in the gas phase. Thereby, the flame spread velocity is affected. Thus, tests which presume to establish relative flame spread characteristics of polymeric materials in a definitive manner are valid only for the particular conditions of the test and may give misleading results if extrapolated to other conditions.

Small-scale laboratory screening tests in this potentially misleading category



## TEST METHODS AND STANDARDS

include ASTM D-635, D-1692 and UL94. All of these tests are claimed to be useful for determining the relative or comparative burning characteristics of materials. Actually they compare the behavior of materials only under the unique conditions of the test. Changing the specimen size, thickness, orientation or initial temperature, or changing any of the environmental conditions, changes the magnitudes and relative importance of the heat transfer modes involved and thus changes the flame spread velocities and, very likely, the relative flame spread characteristics of various materials. Also, since none of these tests simulates the important energy feedback from the surroundings that occurs in real fires, the magnitude of the observed spreading flame velocity is unrealistically low. It cannot be assumed that any of these small-scale laboratory screening tests meaningfully "rank" the flame spread characteristics of materials in any other size, geometry, and "fire" condition but the precise one tested.

When a material is used as an interior wall or ceiling finish material, it will affect the fire hazard at the place of use according to the extent to which it permits spread of flame over its surface, contributes fuel to the fire, or generates smoke and toxic gases when burning. In the United States, the Steiner Tunnel Test (ASTM E 84) is the most widely used procedure to measure the potential hazard of room lining materials. While this test reports measurements of fuel contribution, smoke density and rate of flame spread, it is primarily used to determine flame spread. Despite considerable discussion and objection regarding technical details of the test, the ratings resulting from this method have widespread use. They are used in several national model building codes, many local codes, and by various regulatory bodies primarily as means for limiting the use of combustible interior finish materials in buildings.

ASTM E 84, developed by Steiner in the early 1940's, was predicated on measuring the hazard resulting from fire propagating up a wall or along a ceiling in a room or corridor. The need for an interior wall finish material test was demonstrated by several fires in which the interior finish was the key factor in life loss. The test was developed with the intent of reproducing conditions which would create performance consistent with field experience. Such conditions were created by adjustments of the fuel and air supply until the fire hazard properties of known materials were properly ranked. At that time, experience was solely with wood and similar cellulosic materials, and the test was developed to provide a basis for comparison of the flame spread hazard of these materials.

ASTM E 84 seemed adequate until the development and use of certain types of synthetic polymeric materials such as low density polyurethane and polystyrene foams, and several types of thermoplastics. The test method does not provide a satisfactory rating for materials which soften, melt and drip or are of very low density.

Thermoplastic foams rapidly melt in the vicinity of the impinging gas flame and pull away from the roof support. This physical phenomenon prevents flame spread down the tunnel and consequently the material is given a low flame spread rating.



Meanwhile, the drippings continue to burn on the tunnel floor, yet this obvious hazard in real life situations is not reflected in the calculation of flame spread classification, although it is recorded as an observation in the test report.

The low density of these foams also results in a misleading indication of fire hazard in this test. Due to low density and hence a low thermal conductivity, only a thin surface layer of foam is heated by the hot gases in the tunnel. Thus, the rate of production of combustible pyrolysis gases is low and the gases are swept away before burning. In a room fire however, these combustible pyrolysis gases would be confined and eventually burn, augmenting the fire intensity in the room. Thus, some materials actually burn in a very hazardous manner whereas the test indicates that they should not.

Therefore, ASTM E 84 should not be employed as the sole criterion for fire hazard of interior finish materials until such time as the test is modified to correct for the above mentioned shortcomings.

Work on the utility of this test for synthetic polymers, especially foams, is underway. For example, Christian and Waterman (1970) in a series of tests for the Society of the Plastic Industry, employed a corridor to evaluate the correlation of the ASTM E 84 flame spread classification for materials used on the walls and ceiling with fire behavior. The fire was originated in a 10 X 15 ft (3.1 X 4.6 m) room with an 8 ft (2.4 m) high ceiling adjacent to the corridor. They measured the time for various linings to burn the length of the corridor. They concluded "It is clear that placement of the materials in the order of ascending tunnel test flame spread ratings does not quite place them in the order of increasing flame spread rate or decreasing time in the full-scale corridor."

In a recent series of tests conducted at Underwriters Laboratories (Castino et al. 1975), the flashover characteristics of rooms lined with low density foamed plastics and other common building materials used for interior finishes were investigated. Various ignition sources were employed. It was concluded that:

"Total incident heat flux levels in the test flame area of the 25 ft tunnel test are comparable to heat fluxes in the flame area of a 20 lb. burning wood crib ignition source in a corner geometry."

A major conclusion of this report is:

"The flame spread classification of materials developed in the standard 25 ft tunnel test corresponds with the performance of those materials in corridor, corner and vertical-wall full-scale building geometry tests."

This conclusion was based on a criterion for acceptance, namely the determination of whether the room reached flashover conditions as evidenced by a ceiling maximum temperature greater than 649°C (1200°F) or whether full ceiling involvement occurred.

However, if the time to flashover is employed as the criterion for hazard, then a different conclusion would be reached. Specifically, studying Table 5.2, constructed from data in the Underwriters Laboratory report one readily sees little correlation of time to flashover with flame spread classification — in fact, for

## TEST METHODS AND STANDARDS

*Table 5.2. Time to Full Ceiling Involvement (with 20 lb crib)*

Sample	Material	Room Tests	
		E-84 FSC	Time:min:sec
S	Polyisocyanurate foam, FR	22	1:20
A	Polyisocyanurate foam, FP	23	1:40
G	Treated plywood	23	--*
H	Untreated plywood	178	4:20
Corner Tests			
J	Untreated fiber board	54	10:10
O	Polyurethane foam, FR	59	1:22
AD	Polyurethane foam, FP	75	0:40
AE	Red Oak	100	8:45
U	Untreated particle board	156	3:15
K	Untreated plywood	159	4:00
AC	Polyisocyanurate foam, FR	364	1:25
D	Polyurethane foam, FR	925	1:30
O	Polyurethane foam, FR	1735	0:22

\* Not reached in 20 minutes  
FR - flame retardant

materials with the same classification, flashover times can vary by an order of magnitude. Also, these data indicate that cellulosic materials used as room linings, produce a different (and seemingly lesser) degree of hazard than polymeric foams having the same flame spread classification.

The examples in Table 5.2 show that the ASTM E 84 test does not consistently measure the hazard from wall and ceilings linings, particularly when some new synthetic plastics are employed. Much additional work is required to determine to what extent and for which materials this test can adequately measure fire hazard.

In the late 1950's, the National Bureau of Standards developed the radiant panel test with the specific objective of providing a relatively simple and reproducible method for measuring the surface flammability of materials. It was expected that if such a test method could be provided it would be widely used for research and quality-control purposes in the manufacture of building finish materials. This test method was recognized by ASTM in 1960 (E-162). E-162 is being used increasingly in building codes and material specifications even though the standards includes a statement that it is not intended for such purposes.

The test recognizes two important factors in characterizing surface flammability: (1) the critical energy flux necessary to propagate the flame and (2) the rate of heat liberated during flame spread. Moreover, the radiant-panel test method permits separate measurement of these two properties during a single test. The proportionality constant used in the calculation of flame spread index was selected to

provide some measure of agreement between the resulting index and that derived from the ASTM E 84 tunnel method, particularly over the range of flame-spread indices of about 10 to 150. However, data with synthetic polymeric materials indicates that the correlation between these two tests is uncertain.

It seems fair to suggest that use of both the Steiner tunnel test and the radiant-panel method has provided a considerable advance to our understanding of the flammability behavior of solids. However, a need still exists to conduct carefully planned research on the relevance of currently used surface flame spread ratings to determine fire hazard particularly in the case of synthetic polymeric building finish materials. Prior to the completion of such research, it seems premature to assume that these or any other surface flame spread test methods are capable of rating materials correctly.

Some tests in which flame spread is a factor have been developed to measure a specific hazard. For example, ASTM E 108 measures the surface flammability of roof coverings, in the configuration and under exposure conditions which might be typical of a real fire. This test, and UL 790 that specified the acceptable limits, seems to be a reasonable approach to classifying roof coverings.

In a recent case, fire dynamics considerations were used in the development of a test for fire spread along a corridor with a combustible floor covering, e.g., carpeting. In this case, fire experiments were performed in a corridor. The radiation from the ceiling, as well as from the burning gases just below the ceiling was identified as critical in promoting a "flameover condition" (propagation rates of the order of a foot per second) over the floor covering. Thus a test method was developed, the Flooring Radiant Panel Test, involving radiant heat impinging on a floor-covering sample, with piloted ignition at one end. In this test, the flame starts in a region of high radiation flux and propagates to regions of progressively lower radiant flux; then, at some point, the flame ceases to advance. The acceptance criterion is the radiant flux level below which propagation must not occur. This critical flux, in the range of 0.25 to 0.5 watts/sq cm, is set depending on the occupancy considered. Fire dynamics studies established the importance of radiation flux and provided guidance as to a proper value for the critical flux. This test method offers an excellent example of how a test method should be developed and demonstrates a rational relationship to the hazard it is designed to control.

Flame spread is important from a fire safety aspect in polymeric coated cables. To evaluate the hazard properly it is essential that heat feedback to the burned and unburned cable be simulated realistically. Typically single strands of cable exhibit low flammability when tested in the open (e.g., UL 44 and UL 83), But, they have been shown to have contributed significantly to fire spread in a wall cavity. IEEE Test 383 addresses the deficiency mentioned above and, hence, is an improvement; however, the committee feels that this test still does not insure total safety.

In summary, the surface flammability characteristics of materials are important and should be evaluated. However, since the flame spread process is strongly con-

trolled by the magnitude and relative importance of the heat transfer modes involved, small-scale tests designed to provide relative comparisons of hazards have very limited meaning because they fail to model thermal energy feedback correctly.

On the other hand, small-scale tests developed to simulate a specific surface flammability hazard (e.g., flooring carpet test) can be quite effective in controlling the particular hazard. At this time it is not clear what is the most effective approach for classifying the hazard posed by wall and ceiling finish materials. ASTM E 84 (or possibly ASTM E 162) and the corner test (to be discussed later), in contrast to a complete full-scale burn, may be useful for evaluating these materials.

Much work must be done to correlate surface flammability test ratings to full-scale fire behavior hazard; but, it is unlikely that any one flame spread test will allow prediction of the surface flammability hazard of all materials in all situations.

#### 5.4.3 Rate of Heat Release Tests

In recent years, there has arisen growing support of the concept that the rate at which heat is released during burning is an important criterion for evaluating the fire hazard from a particular material. It is considered to be a significant "characteristic" of room linings, and it must also be an important parameter of room contents that could contribute to early fire growth.

Since the rate of heat release is thought to be most important during the "steady" burning period following flame spread, it is a measure distinct from ignitability or surface flame spread potential, and is considered to be of greatest significance in the stage of fire growth preceding flashover.

The rate of heat release from initially ignited material(s) has a significant influence on local fire intensity and hence on the subsequent development of a fire since 1) the intensity of the fire strongly influences the probability of secondary ignition of nearby objects; 2) the fire intensity determines the rate of buildup of smoke and toxic gases in the room of fire origin as well as throughout the building containing the fire; and, 3) all fire suppression techniques become ineffective once the fire intensity has grown beyond some critical level. Thus a basis for the importance of the rate of heat release concept is readily established.

The concept of rate of heat release had its origins in the earlier work of Steiner (1943) when he described the measurement of "fuel contributed" along with flame spread rate in his newly developed tunnel test (ASTM E 84). While Steiner did not describe his plot of flue-gas temperature vs time as a rate of heat release curve, it was, in fact, a measure of the rate of heat release during the stages of surface flame spread and subsequent burning of the specimen. Thirteen years later, Robertson, Gross, and Loftus (1956) in what is now ASTM E 162, combined a flame spread rate with a factor involving the rate of heat generated by the material under test to determine a flame spread index for that material. Both of these are essentially tests for surface flame spread, and, when evaluating heat release, these tests only report total heat release, and only provide information relative to red oak (ASTM E 84)

or hardboard (ASTM E 162). However, reference to the time-gas temperature data could yield rate of heat release measurements. These measurements would include heat released during flame spread and steady state burning, in contrast to current proposed measurements which focus primarily on the steady burning period.

The first instrument designed specifically to determine rate of heat release was the FM Construction Materials Calorimeter developed at Factory Mutual Laboratories (Thompson and Consima 1959). Recently, instruments have been developed at the National Bureau of Standards (Parker and Long 1972), Ohio State University (Smith 1972), Stanford Research Institute (Amero et al. 1974) and Forest Products Laboratory (Branden) to measure the rate at which heat is released from a burning material.

In a typical heat release rate calorimeter (HRRC), a sample of material, of known physical and chemical composition, is exposed to a controlled air flow and an external radiant heat flux simultaneously. In some instances, a pilot ignition source is provided at the bottom edge of the sample. The back surface of the specimen is either insulated or water-cooled. In the latter case, the temperature rise of the water stream is used to calculate the heat "released" through the specimen back surface. A secondary gas burner may be present in the flue stack. Once the specimen is ignited, heat is released as a function of time. This released heat may be measured directly or by substitution, by operating the calorimeter in either an isothermal or adiabatic mode.

The HRRC is an attempt to duplicate the path taken by materials in their consumption during a fire. Hence, the heat release rate measured with the HRRC is an extrinsic property of the test method which is affected by a number of factors, e.g., the specimen geometry and orientation, the availability of air and the air flow velocity, external heating, heat losses to the calorimeter walls, dripping, charring, etc. Since the rate of heat release is *not* a fundamental physicochemical property of a material, one would properly expect that employing different "fire conditions" in different HRRC's would yield different measures of rate of heat release.

The development of a test method generally includes three stages: the evolution of a concept, the design and development of an instrument to measure a quantity based on the concept, and the application of the measurements to a specific situation. These methods for rate of heat release are presently at the second stage; consequently little if any data are available that correlate rate of heat release measurements with large scale fire behavior. This step should follow soon. Criteria can then be developed, based on rate of heat release data, to improve the fire safety of materials in use. Meanwhile, more data are needed to fully evaluate the performance characteristics and reproducibility of the currently available instruments; the design is still in a state of flux. Rate of heat release measurements should be standardized by ASTM or other appropriate organizations.

#### 5.4.4 Tests for Oxygen Requirement

Since its introduction (Fenimore and Martin 1966), the Oxygen Index Test has

achieved wide popularity as a means of characterizing the flammability of materials. Its desirable attributes include simplicity of equipment and ease of operation, good reproducibility, good differentiation among materials, versatility, and the use of small, easily prepared test specimens. It has become a valuable tool for use in the preliminary stages of product development and for quality control purposes. The standard version of the Oxygen Index Test, ASTM D2863, is applicable to plastics including solid, cellular, and film forms. A similar procedure has been used extensively for textile materials.

In ASTM D2863, the sample is ignited at the top and burns downward with a small candle-like laminar flame. Energy from the flame is dissipated to the cool surroundings and there is little energy feedback to support the combustion of the sample. This is in sharp contrast with the hot turbulent radiative environment characteristic of most real fires. For these reasons, the test is of little value in characterizing the behavior of materials under conditions encountered in real fires.

Numerous variations of the standard test have been used for experimental purposes. Ignition of the sample at the bottom with upward burning gives a substantially lower value for the critical oxygen concentration than does the conventional top burning configuration (Stuetz et al. 1972). This is due to more effective heating of the sample by the flame plume and, perhaps, better mixing of oxygen with the fuel gases. It has been found that a standard oxygen index of approximately 27 is needed to assure that a small sample of material will be self-extinguishing when ignited at the bottom in air (20.9 percent oxygen).

Thermoplastic materials present problems in the standard test because of melting and dripping. The melt carries heat away from the combustion zone so a higher oxygen concentration is needed to maintain the heat balance at the burning surface. To avoid this problem, wicks or cup type sample holders have been used to hold the melt in place. Good correlations of oxygen index with polymer viscosity have been observed (Reimschuessel et al. 1973). This may be important in studying the effects of additives on polymer flammability characteristics. Additives which lower the melt viscosity may increase the oxygen index, giving a false indication of flame retardant action not supported by other tests.

The oxygen index decreases with an increase in the initial sample temperature since less energy feedback is needed to maintain the burning surface of the sample at the required temperature. This can be a cause of error when the apparatus becomes heated from successive tests.

Routley (1973) has suggested making use of this effect by measuring the oxygen index as a function of temperature and taking the temperature at which  $OI = 20.9$  (burning in air) as a measure of material flammability. This appears to be a useful suggestion since almost all real fires involve pre-heated fuels at an oxygen concentration at or below that of air. The oxygen sensitivity, the rate of change of  $OI$  with temperature in the atmospheric oxygen concentration region, may be another useful measure of flammability.



While the Oxygen Index Test provides a way of comparing the relative flammability of similar polymeric compositions under closely controlled laboratory conditions, recourse must be had to test methods providing a much more severe fire exposure in order to predict the performance of a material under conditions likely to be encountered in real fires.

#### 5.4.5 Extinguishment Tests

There are no current test methods to evaluate the ease of extinguishment of polymeric materials. However it is useful to highlight what is currently known about the extinguishment of polymeric materials and to consider the potential for extinguishment tests.

##### 5.4.5.1 Portable Extinguishers

In terms of extinguishment, combustibles are classified by NFPA in four categories:

- Class A: "ordinary combustible materials, such as wood, cloth, paper, rubber, and many plastics"
- Class B: "flammable liquids, gases, and greases"
- Class C: "energized electrical equipment"
- Class D: "combustible metals, such as magnesium, titanium, zirconium, sodium, and potassium."

As is well known, more than half the tonnage of synthetic polymers in current use consists of materials which fuse on application of heat to produce a low-viscosity melt. Polyethylene and polystyrene are major examples. On the other hand, some polymers produce a rather viscous melt which tends to stay in place rather than flow (e.g., polymethylmethacrylate), and yet others char rather than melt (e.g., phenol-formaldehyde).

Furthermore, different solids of the same size and shape which are fully ignited will burn at different rates. For example, Magee and Reitz (1975) found that, for horizontal square slabs of 317 cm<sup>2</sup> area, the burning rate (gm/cm<sup>2</sup>-sec) was three times as great for polystyrene as for polyethylene. Char-forming materials burn even slower relative to polystyrene, which is the fastest burning unfoamed solid of more than a dozen tested. On the other hand, liquid styrene monomer burns more than three times as fast as solid polystyrene, under certain conditions (Tewarson 1975).

There is no standardized way of rating ease of extinguishment of various combustibles which takes into account the factors of different burning rate and different tendency to form a fluid melt, except in the sense of a Class A versus a Class B classification. As the quoted definitions suggest, plastics are generally taken to be Class A combustibles. Portable (hand-held) extinguishers intended for Class A fires are tested by approval agencies (Underwriters Laboratory, Factory Mutual) for their ability to extinguish a specified stack of hard-wood pallets, after a specified

preburn time. (Excelsior (wood shavings) is sometimes used to represent a Class A combustible in these tests).

Class B combustibles are simulated by a square steel pan containing n-heptane. The larger the capacity of the extinguisher, the larger the area of test fire which must be extinguished in an approval test. For example, using a 6 kg extinguisher containing dry chemical agent, an experienced operator should be able to extinguish a test fire of 1.8 square meters.

It is probable that a fire involving a polymer which forms a fluid melt can be controlled by an extinguisher intended for Class B fires. Application of water to such a fire could cause spattering and temporary augmentation of burning rate, but continued application of water would cool the polymer to a nonburning state. Note that the heat of gasification of a molten polymer is several times as high as that of organic liquids such as heptane or benzene. Further, the flash point of the polymer is much higher, so molten polymer fires would be considerably less difficult to extinguish than heptane fires. On the other hand, if the polymer is a smoldering cellular material, the fire being deep-seated, attack with a Class A extinguisher (rather than Class B) would appear to be more appropriate.

The foregoing paragraph is a summary of the fire protection engineer's knowledge about fighting polymer fires with hand-held extinguishers. There are no standardized test methods to determine the best extinguisher for a particular polymeric combustible, or, conversely, to determine the relative ease of extinguishment of a series of polymeric combustibles by a given extinguisher. Such test methods might be useful, but the value would be limited severely by two factors. First, a given portable extinguisher may be used to fight fires of a wide variety of materials, making optimization difficult. Second, the difficulty of fighting a fire depends more on the size of the fire than on the type of combustible. Therefore, factors such as spread rate, time of detection, ready availability of extinguisher, etc., may be much more important than specific effectiveness of a given extinguishing agent on a given polymeric fire. Hence, the need for better test methods in this area would appear to have low priority.

### **5.4.5.2 Automatic Sprinklers**

Automatic sprinklers to protect buildings are specified on the basis of the delivered water density (generally between 0.1 and 0.6 gallons/min-square foot) and the maximum foreseeable water demand (sometimes as large as several thousand gallons/min). The cost of installing the sprinkler system is highly dependent on these design parameters.

The water density required to control a fire obviously depends on the type, quantity, and arrangement of combustible present (Magee and Reitz 1975). Polymeric materials in some cases, because of high burning rates, may present especially severe challenges to sprinkler systems. However, in general, fire loss to property, especially commercial and industrial property, has been tremendously reduced when automatic sprinklers have been present. Insurance statistics show that the



expected loss due to fire in sprinklered properties is about \$2 per year per \$10,000 value. Data suggest that it is about an order of magnitude higher for unsprinklered property.

Private residences are virtually all unsprinklered, because of cost. A minor proportion of hotels, school dormitories, etc. are sprinklered. A greater proportion of nursing homes, restaurants, etc. are sprinklered, depending on local ordinances. An accurate knowledge of the minimum water application rate and quantity required to control fires of polymeric materials would be of great value in judging cost effectiveness of introducing sprinklers versus modifying or banning polymeric combustibles to achieve a desired level of fire safety.

In contrast to industrial fires under high ceilings, there is very little experience bearing on the minimum sprinkler requirement for a fire in a normal-size residential room. There is reason to believe that very little water may suffice to control such a fire. However, if it is necessary to spray the water directly on the burning object, there is difficulty in locating a sprinkler head so that the spray will impinge on every potential combustible in the room; if several sprinkler heads are needed per room the installation cost is obviously high. Kung (1975) has developed data relevant to another concept — i.e. spraying the sprinkler water into the fire gases and onto the hot ceiling and walls so as to generate steam which may extinguish the fire by inerting. Less than 0.05 gal/min-square foot may be adequate. Much testing is needed with realistically furnished rooms before standards can be specified.

The action of the sprinkler to control the fire is in part by inerting (both by steam and by entrained combustion products), in part by direct wetting of the pyrolyzing solid, in part by pre-wetting not-yet-ignited materials, in part by cooling the fire gases and thus reducing radiative transfer to combustibles, and in part by creating a fog which itself blocks radiative transfer. In view of these multiple effects, there seems to be little chance that a small scale test method evaluating any one of these effects will suffice to determine minimum water application rate for a given polymeric commodity.

#### **5.4.6 Tests for Smoke Evolution**

Tests for smoke evolution are important to fire safety because the presence of smoke affects the ability of occupants to escape from a burning structure and the ability of firefighters to control and extinguish the fire. Most existing smoke methods are concerned with vision obscuration, and therefore seek to measure smoke density by either optical or gravimetric techniques. No smoke method presently in use addresses an important aspect, the lachrymatory and irritant characteristics of smoke which can obscure vision even more effectively than optical density in the atmosphere.

The NBS smoke density chamber is a widely used apparatus for measuring smoke density. This chamber represents a means of evaluating the relative smoke-producing characteristics of a material in terms of obscuration, and much of the

discussion here will address it because there is only one other test method which could be considered a serious contender, the ASTM D 2843 test.

The NBS smoke density test method, also designated NFPA 258, exposes a specimen 3 inches square to a radiant heat flux of  $2.5 \text{ W/cm}^2$ , either in the presence or in the absence of a pilot flame (flaming or smoldering mode, respectively). The smoke evolved is accumulated in an enclosure with a volume of  $18 \text{ ft}^3$ , and optical density is measured along a vertical light path 3 ft long. The results are expressed in values of specific optical density (Ds), and the maximum value is designated as Dm.

It is when the use of the test method is expanded from its basic function of obtaining comparable data on materials that some aspects become questionable. As examples, consider the following:

1. The maximum value of specific optical density, Dm, is corrected by subtracting the optical density due to soot deposited on the optical system. This procedure favors heavy soot-depositing materials such as polystyrene to the possible detriment of fire safety. The soot deposited on the exposed surfaces of the optical system was obviously in the atmosphere obstructing vision at some time during the test, and its propensity for depositing on an exposed surface makes it even more likely to obscure vision through irritation and lachrymation, yet the correction procedure rewards rather than penalizes this characteristic behavior. The FAA proposal to use Ds values at 1.5 and 4.0 minutes is to be commended because it avoids the correction step. Fortunately for public safety, the Dm values for heavy soot-depositing materials are so high even with the correction that these materials are still recognized as hazardous.
2. Specific optical density is a useful scale for expressing relative smoke density. Its use in extrapolating values to larger enclosures, however, can be questionable. As smoke density increases, multiple scattering effects can become appreciable. It is generally agreed that multiple scattering is not significant at Ds values up to 16, but extrapolating Ds values over 200 to larger enclosures gives dubious results.
3. The vertical specimen position permits materials to melt and thereby yield unrealistically low values. This is because the molten material either is subject to less heat in the specimen holder trough or overflows the trough and escapes exposure entirely.

The NBS chamber offers the advantages of considerable versatility, such as the addition of controlled ventilation, continuous specimen weight monitoring, and analytical bioassay devices for measuring toxicity. It offers one-dimensional heat flux, which is essential for evaluating composite structures which are expected to encounter heat flux on only one side.

The ASTM D 2843 test is a useful laboratory screening test, and can distinguish gross differences between materials at substantially less cost than with the NBS smoke chamber. The horizontal photometer light path at a fixed height tends to

favor materials which produce dense smoke that may not rise to the level of the light path.

The ASTM E 84 test is primarily a test for surface flame spread, however in the past a great many materials have been tested for smoke evolution by this test method. It is desirable that smoke evolution be measured in a test specifically designed for this measurement since important parameters for smoke development testing are not controlled in ASTM E-84.

#### **5.4.7 Tests for the Assessment of the Toxicological Aspects of Pyrolysis and Combustion Products**

In general, smoke and toxic gases are far more important than heat and flame as causes of building fire fatalities. According to our present knowledge, carbon monoxide is the chief toxicant. However, with the introduction of new synthetic polymeric materials and products into building construction and furnishings, the potential for the production of new toxicants, e.g., HCN or HCl now exists. The situation is further complicated by the use of fire retardants to inhibit ignitability and surface flame spread. During combustion certain retardants under some conditions can combine with elements in the polymer to form extremely toxic airborne products. It has been reported (private communication, M. M. Birky, U.S. National Bureau of Standards) that the French Government (Salt Lake City, Utah 1976), in an attempt to reduce this hazard, had promulgated a "toxicity standard," which simply sets an upper limit to the quantities of various elements, (chlorine and nitrogen), permissible in materials in a given building volume. This approach is much too simplistic to insure control of toxic products. For a more sophisticated discussion the reader is referred to Volume 3 of this study.

When a polymeric material is thermally decomposed, under either oxidative pyrolysis or flaming combustion conditions, a mixture of substances comprising gases, aerosols, particulates and chars is produced. It is difficult to establish whether the intoxication syndrome (the signs and symptoms of intoxication produced on exposure to these decomposition products) is produced as a consequence of the action of one, some, or all of the substances present in these products. Furthermore, combustion toxicology is inherently complex because relatively minor variations in testing procedure frequently result in major changes in the actual dose of toxicants produced. Such testing variations include the level of incident heat flux used, the duration of heating, whether combustion is flaming or non-flaming, the physical configuration of fuel, the relative mass of the material degraded, amount of air flow used, etc. Essentially these variations represent a sampling of the various parameters which constantly are changing in a real life fire.

The purpose for investigating the toxicity of a material's pyrolysis and combustion products is to permit the evaluation of potential hazards that might arise from the use of that material in a product or system. Fire safety toxicity standards for materials have largely ignored the complexity of the problem and are many times grossly over-simplified. A statement such as "shall be no more toxic than

wood," used in some building codes, is virtually meaningless. It does not indicate how this determination should be made, nor whether the proposed material is used in comparable amounts or under equivalent conditions. Further, the toxicity of the decomposition products of wood varies greatly depending on species and combustion conditions. The present situation is confused and may even be described as chaotic.

### **Approaches to Toxicity Assessment**

Tests for toxic gas assessment use one, or both, of two approaches: 1) identification and analysis of the chemical compounds in the decomposition products, and 2) exposure of laboratory animals to the decomposition products; in summary, analysis or bioassay.

The analytical approach is based on the philosophy that if only a limited number of chemical compounds are responsible for essentially all the toxic effects, then analysis for these particular compounds would permit prediction of essentially all the toxic effects which could be expected. However, the analytical approach suffers for the following reasons. First, a basic weakness of the analytical approach is the assumption that knowledge of the complex mixture of decomposition products produced under a given set of fire conditions can lead to a satisfactory prediction of their combined toxic effects. Second, the biological activity of a compound may make it of great importance in the production of the intoxication syndrome, but its concentration may be very low and consequently not suspected to be significant, or it may not even be detectable by "common" techniques.

For these reasons it should be mandatory to use laboratory animals during a first-tier screening assessment of combustion product toxicology.

Where the analytical approach calls for analysis followed by prediction of toxic effects on the basis of incomplete data for pure gases, the bioassay technique directly measures the effect of the combustion products on a biological system, and bypasses all the intervening uncertainties. Since human beings cannot be used in such experiments, a choice of test animal must be made; mice and rats are the species of choice in most tests. There are differences of opinion as to which species, and which strain of that species, is more suitable for predicting human responses. Rats are the preferred species for general toxicologic studies since they provide a more ready supply of blood for analysis. Mice are recommended for sensory irritation studies and some behavioral tests.

### **Apparatus and Procedure**

Although many apparatuses and procedures have been developed, there is no standard apparatus and/or procedure utilizing the bioassay approach which is widely accepted. The available test apparatuses differ in size, location of the test animals, method of toxic product production, and amount of air flow used. A major problem in animal toxicity testing, in addition to the means of combustion gas production, is the need to separate the animals from the burning polymer to

minimize heat stressing. The result is that the combustion products must travel some distance before reaching the animal. The time of travel and the accompanying heat losses can drastically affect the composition of the toxic species to which the animals are eventually exposed. Furthermore, reactions with and/or condensation on the exposed surfaces of the apparatus may also affect exposure conditions.

An appropriate screening test procedure should incorporate both a behavioral end point (loss of avoidance or other means of evaluating the animals incapacitation) and a bioassay (appropriate monitoring of the physiological status of the animal such as blood chemistry, heart rate, breathing rate, etc.). Time of death is frequently taken as an end point because of convenience, but incapacitation may bear a more meaningful relation to fire hazard.

It seems apparent that the use of only one set of combustion conditions to evaluate a material or to attempt to compare different materials at a single condition may be inadequate. There is no *a priori* reason to expect that the behavior of a material under any one set of conditions is representative of its behavior under other sets of conditions.

Thus a matrix must be used to provide an appropriate set of exposure conditions which may then be used to assess a material's potential toxicological hazard. The material must be exposed to nonflaming as well as flaming conditions so as to be able to evaluate its contribution to hazard in the smoldering state, at the point of flaming ignition, and during the post-flaming state. In addition to varying the heat flux and nature of the combustion conditions, the matrix must also provide data pertaining to concentration-response or dose-response. (A dose indicates the amount of chemical administered at a specific interval of time). The simplest procedure is to select a sample weight, perform the test, count the number of dead animals at the end, and report percent mortality. This provides one scale of comparison, from 0 to 100 percent; however, when a wide range of materials are tested at a single exposure level many tend to fall either at 0 or 100. The single result of either 100 percent death or 100 percent survival tells relatively little about the lowest dose likely to be lethal and how the material under consideration compares with other materials. Preferably, comparison should be made on the basis of response at several dose levels, as shown in Figure 5.1, which illustrates the type of graph resulting from doses plotted on a log scale against percent mortality for two substances identified as A and B. From the graph it is clear that at dose X, both A and B are equally lethal, whereas at dose Y, A is more lethal than B, and at dose Z, B is more lethal than A. No single point would give this information. Incapacitation data can be treated similarly.

### Summary

In typical, uncontrolled fire, conditions are continually changing, resulting in varying exposure conditions, e.g., heat flux, air flow, etc. The toxic environment is continually changing as well. Small scale tests are designed to give a measure of the specific toxicity (toxicity per unit mass consumed) of a material. In a real fire the

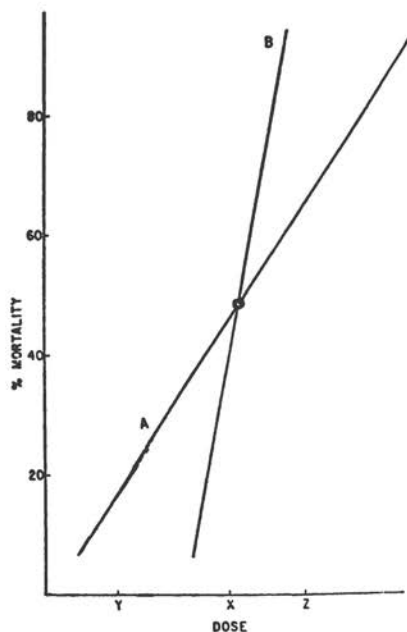

Figure 5.1. Comparison of mortality produced at dose levels X, Y, and Z by substances A and B.

toxic hazard will depend on the concentration of combustion products in the atmosphere, i.e., on the quantity of material burned, the rate at which it burns, and the volume of the system in which the products are dispersed, as well as on the specific toxicity of the material. Thus it is erroneous to expect that simple toxicity tests offer a precise hazard evaluation. Rather, well developed small-scale tests may be profitably used to screen comparable candidate materials under specified degradation conditions and permit the recognition of toxicologically unique pyrolysis or combustion products.

#### 5.4.8 Tests for Fire Endurance

Building fires usually start with one small item, such as a wastepaper basket or a chair. In a serious fire, the small fire eventually grows to involve the whole room. The instant of total room involvement is called "flashover."

The chain of events that leads to a serious fire can be broken in many places. Often the probability of a fire reaching flashover is very small, but a sequence of improbable events can lead to flashover in even the best protected areas. The realization that the worst eventuality is not impossible must lead to an evaluation of how a building would respond to a sustained high-intensity fire, i.e., a "post-flashover" fire.

Fire endurance may be defined as the resistance by a component or assembly to the passage of fire. This characteristic is related to the fire containment per-



formance of a wall, ceiling or floor section. Usually it is assumed that the fire has reached full involvement in one space; fire endurance relates to *how long* the barriers will resist the passage of fire. The fire endurance tests must generally be imposed on all elements of construction; doors, walls, floor/ceiling assemblies, columns and other structural elements. In the final analysis this property is related to the ability of an element to contain a fire. Fire endurance tests are intended to measure this property. It should be noted that this property is sometimes very sensitive to construction details and the real world durability of the construction. Penetration in the walls or ceiling for the passage of pipes, cables or other services should be so designed that their presence does not decrease the fire endurance.

A number of factors, such as ventilation, fuel load, and thermal properties of the structure, have a controlling influence on fire intensity at any instant. The historical development of the standard fire exposure which forms the basis for all fire endurance tests in the United States is reviewed in Volume 2, Chapter 5.

The most common test for fire endurance is ASTM E 119, which measures the fire endurance of complete wall assemblies, floors/ceilings, and individual structural elements (e.g., columns, beams, girders, etc.). The tests for doors and windows, ASTM E 152 and ASTM E 163, are essentially the same as ASTM E 119; now, however, full-scale doors and windows are installed in walls of different constructions.

The most important aspect of the ASTM E 119 fire test and all similar post-flashover tests is that the test purports to allow the evaluation of performance of a structural element under a standard fire exposure. The test is not used to evaluate whether the structural element will contribute to the propagation of a fire within a compartment, but rather the fire containment performance of the element.

The ASTM E 119 test can be used to compare various building structural components. Polymeric materials have been used in many assemblies that have passed the ASTM E 119 test for periods from twenty minutes to two and even three hours. In most cases the polymeric material has been protected by a thermal barrier, such as gypsum wall board, and the polymers were not involved until the later portion of the test period.

Maintenance of a positive pressure within the furnace would probably improve the ASTM E 119 test method, but at this time there are no requirements for measuring or regulating the relative pressure between the inside and outside of the furnace. Some laboratories conduct the test with a negative pressure over the entire face of the specimen which results in room temperature air being drawn through any openings in the unexposed surface of a wall or floor specimen. This means that any flaming within the assembly would have a tendency to be drawn into the furnace rather than out through the opening. Under actual fire conditions in fully involved compartments, a positive pressure exists in the upper two thirds of the compartment. It is particularly important that E 119 tests be conducted with a positive pressure on at least the upper two thirds of wall specimens if there are openings in the wall. An important example of this is when pipe and conduit

penetrations are being tested in the E 119 test. Another important case is when doors and windows are tested by ASTM E 152 and ASTM E 163. As with pipe penetrations it is important to conduct the test with a positive pressure at the top of the door or window to simulate actual fire conditions.

#### 5.4.9 Full-Scale Fire Tests

Full-scale fire experiments have been the traditional precursors of standardized fire tests. Some of the earliest experiments were conducted in the 1790's (Hamilton 1959) and there were extensive efforts in the late 1890's to develop quantitative measures of post-flashover fire performance. These led to the standardization of the fire endurance tests such as the ASTM E 119 discussed in the preceding section. There were subsequent full-scale experiments conducted by Ingberg in the 1920's and 30's at the National Bureau of Standards to further establish the meaning of fire endurance.

More recently there has been increased activity in the use of full-scale tests, particularly to evaluate the contribution of synthetic polymeric materials to early fire growth. In most cases, these tests have been *ad hoc* evaluations of fire performance which have not been based on any standardized procedure.

Recognition of the need for large-scale tests has grown with realization that the existing small-scale tests are not adequate to evaluate fire hazard consistently for all materials. The discrepancy between simulated real-life situations and small-scale tests has been well documented. The problem was brought to a head when the Federal Trade Commission issued its proposed rule on cellular plastics products (FTC 1975). The Commission said, in effect, that the "Standard Method of Test for Surface Burning Characteristics of Building Materials," variously denoted as ASTM E 84, UL 723, NFPA 255, did not, alone, constitute a reasonable basis for certification, since it did not determine the combustion characteristics of the materials under actual fire conditions.

As a result of the FTC action there has been an intensified search by industry and the building code community to determine what is a reasonable basis for substantiating fire performance of materials. The end result of this search has more or less centered on the concept of using a room test for the evaluation of wall and ceiling linings in lieu of, or as a supplement to, the existing E 84 test procedure. ASTM Committee E 39<sup>1</sup>, in response to the need for a standard room test established a taskgroup to develop a recommended practice. As a result, Task Group 4 of ASTME-39.10.01 developed a Guide for Room Fire Experiments (ASTM E-603-77) to provide direction to the research or testing agency. The purpose of the Guide is to provide a document based on the information and experiences now available from those actively engaged in this type of testing. The task group hesitated to attempt to develop a test method, since the state of the art is still not settled.

---

<sup>1</sup> Now merged into ASTM E 5.



However, the document that was produced attempted to give in detail the various factors which should be taken into account in the design of a room or compartment test.

The task group discussed in their Guide such things as room size and shape, ventilation, specimen description, ignition source, instrumentation, and safety considerations. These represent an important range of choices which must reflect to some degree the nature and type of fire scenario to be protected against. For example, just looking at the decisions to be made on the size, nature and type of the ignition source, indicates the complexity involved in deciding on the nature of a room test.

The ignition source in any fire will have a large effect on the total performance in the room. In fact, the ignition source may become a critical factor in determining how and when a lining may be involved in a fire. In some of the earliest work on evaluating linings, Carson and Lucas (1950) did an extensive study of ignition sources, preparatory to conducting a series of full-scale room tests to evaluate linings and wall constructions. The tests were conducted in a 14' X 20' room 12' high. A series of wood cribs were used of 5, 7½, 10, 20 and 30 lbs. weight. The heat release of the fire was measured; the temperatures developed in the room and the maximum flame height were recorded. For a room of this height it took a 20 lb. crib for the flames to reach the ceiling.

Whether the flames reach the ceiling during a test will determine the relative importance of the combustibility of the wall and ceiling linings. If the flames do not touch the ceiling then the combustibility of the wall linings determines if the ceiling material will become involved, since the fire can only reach the ceiling by traveling up the wall lining. If however the flames reach the ceiling because of the size of the ignition source then the combustibility of the wall linings will be a lesser or negligible factor in determining if ignition and spread occurs on the ceiling. To illustrate this point, in work done by Fang (1975) it was found that the importance of the wall in relation to the ceiling lining depended upon the size of the igniting fire. For an igniting fire that did not touch the ceiling — simulating a small upholstered chair — the combustibility of the wall lining became a major factor in the time to flashover in the room. However, when a larger simulated upholstered chair was used, which produced flames that impinged directly on the ceiling, the effect of the wall lining became far less important and the combustibility of the ceiling lining governed the time to flashover. In this case the choice of the size of chair can lead one to differing conclusions on the importance of the wall vs. the ceiling lining.

The room test concept has also been adopted by the International Conference of Building Officials. In Section 1717c, in a recent amendment of their building code, they state that plastic foam may be specifically approved, based on approved diverse tests such as, but not limited to, tunnel tests, fire tests related to actual end use such as a corner test, and an ignition temperature test. As a result of this change the Research Committee of the Uniform Building Code has been attempting to

develop a standardized corner test to be used in conjunction with the application of their code.

A room test can serve many different purposes: two common objectives are:

1. As an acceptance test to qualify products or constructions for use as wall and ceiling linings.
2. To establish the validity of various small-scale tests, which in turn may be used in lieu of the large-scale room test as acceptance tests.

Obviously, the desired objective would be the second one, but until suitable small-scale tests can be found which can be correlated to large-scale fire behavior, room tests may be the only means to adequately evaluate the hazard from interior finish materials.

It has long been suggested by many workers in fire research that the corner formed by the intersection of a ceiling and two walls represents a critical configuration for evaluating the flammability of interior finish materials. For example, a "corner-wall" fire test was one of the comparative tests used at the Forest Products Laboratory (USDA-FPL 1962) to relate the 8-foot tunnel furnace to realistic fire situations. More recently, Maroni (1972) at the Factory Mutual Research Laboratory has reported a large-scale corner test to represent an industrial situation, and Williamson reported on a corner fire test to simulate residential fires (1973). Results from the latter test indicate that some polymeric materials, e.g., polyurethane foam, which obtained low flame spread ratings in the 25-foot tunnel test (ASTM E 84), exhibited intense combustion and high fire hazard when tested in the corner test. Williamson concludes that the corner test is a meaningful test procedure for evaluating the hazard of the newer polymeric building materials. He now reports that the University of California, Berkeley can run this test for the same cost as the 25-foot tunnel test (Private Communication, Williamson 1976).

It would seem that, until better test methods are developed which more accurately measure the fire hazard from interior finish materials, large-scale fire tests, e.g., room tests and corner tests, should be used to evaluate materials and products for acceptability.

## 5.5 Conclusions and Recommendations

### *Conclusions:*

1. In the past, test method development and the formulation of codes and standards to control the fire hazard from building materials has proceeded in a largely unstructured and sometimes haphazard fashion.
2. Test methods have long been developed with limited understanding of the phenomena of fire growth. Knowledge has advanced considerably in the last decade; the development of more meaningful test methods based on fire dynamics can now be attempted.
3. Many test methods and criteria for fire hazard used today were developed on prior experience with cellulosic materials. These tests are not necessarily adequate for the evaluation of fire hazard of synthetic polymers.

4. No single test is adequate to completely evaluate the fire hazard of a particular material.
5. The complexity of *ignition* phenomena makes it impossible to devise a single test for the evaluation of ease of ignition which is applicable to different materials and end-use situations.
6. The rate of *flame spread* is strongly dependent on many physical and geometrical parameters. Thus, tests which presume to establish relative flame spread characteristics of polymeric materials in a definitive manner may be valid only for the particular conditions of the test. They may give misleading results if extrapolated to other conditions.
7. The rate at which *heat is released* during burning is an important criterion for evaluating fire hazard from a particular material. Therefore, tests measuring rate of heat release can be of great significance.
8. The *oxygen index test* provides a handy laboratory diagnostic technique for the development of new materials; however, since it does not model energy feedback realistically, it is not sufficient for characterizing fire hazard, or for basing standards or regulations.
9. There are no standardized test methods for determining relative *ease of extinguishment* for different polymeric materials. In view of the many factors influencing extinguishment, there seems to be little chance that a small-scale test method could be developed to adequately determine, for example, minimum water application rate for a given polymeric material.
10. Tests for *smoke evolution* are important since the presence of smoke is an important parameter of fire hazard. Available tests for smoke evolution yield results which depend greatly on the conditions of testing (e.g., ventilation, heat flux level, sample orientation, etc.).
11. Fire safety *toxicity standards* for materials have largely ignored the complexity of the problem. No accepted toxicity tests are currently available.
12. Current available tests for *fire endurance* are generally satisfactory.
13. *Large-scale tests* are necessary as acceptance tests for polymeric materials and products which incorporate these materials, and to establish the validity of small-scale tests.

*Recommendations:*

1. Require that new tests and standards demonstrate a rational relationship to the hazards they are designed to control.
2. In the development of tests for *ignitability*, simulate well-defined ignition sources and end-use conditions.
3. Continue work on tests for fire hazard of interior finish materials; the currently used ASTM E 84 test must be improved or replaced.
4. Correlate *surface flammability* test ratings to full-scale fire hazard.
5. Continue the current development of tests for *rate of heat release*.
6. Place high priority on the development of more meaningful tests for *smoke evolution*.

## TEST METHODS AND STANDARDS

7. Mandate the use of laboratory animals during a first-tier screening assessment of combustion product *toxicology*.
8. Incorporate both a behavioral end-point and a mortality count in an appropriate *toxicity* screening test.
9. Run the ASTM E 119 *fire endurance* test with a positive pressure on at least the upper two thirds of the furnace wall specimens if there are openings in the wall so as to better correlate the test with actual fire conditions.
10. Reflect the nature and type of fire scenario to be protected against when designing *large-scale* room tests.

### References

- Amaro, A. J., Kanury, A. M., Lipska, A. E. and Martin, S. B., "Thermal Indices from Heat-Release-Rate Calorimetry," Paper No. 37, Presented at the Western States Section of the Combustion Institute Fall Meeting, 1974.
- The American Society for Testing and Materials, E-603-77 — "Guide for Room Fire Experiments."
- Bremden, J. J., "An Apparatus Developed to Measure Rate of Heat Release From Building Materials," Research Paper FPL 217, Forest Products Laboratory, U.S. Department of Agriculture, Madison, Wisconsin.
- Christian, W. J. and Waterman, T. B., "Fire Behavior of Interior Finish Materials," *Fire Technology*, Aug. 1970.
- Carson, R. C. and Lucas, W. R., "Life Hazard of Interior Finishes," Factory Mutual Laboratory Report No. 11760, June 1950.
- Castino, G. T., Beyreis, J. R. and Metes, W. S., "Flammability Studies of Cellular Plastics and Other Building Materials Used for Interior Finishes," Underwriters' Laboratories, Inc., June 13, 1975.
- Fang, J. B., "Fire Buildup in a Room and the Role of Interior Finish Materials," NBS Technical Note 879, June 1975.
- Federal Trade Commission, "Cellular Plastic Products, Disclosure of Combustion Characteristics in Marketing and Certification," *Federal Register*, Vol. 4, No. 142, July 23, 1975, p. 30842.
- Fenimore, C. P. and Martin, F. J., "Candle-Type Test for Flammability of Polymers," *Modern Plastics*, 43, p. 141 (Jan. 1966).
- Forest Products Laboratory Report 2257, "Surface Flammability as Determined by the FPL 8-foot Tunnel Method," U.S. Department of Agriculture, 1962.
- Friedman, R., "A Survey of Knowledge About Idealized Fire Spread Over Surfaces," *Fire Research Abstracts and Reviews*, 10, pp. 1-8 (1968).
- Hamilton, S. B., "A Short History of the Structural Fire Protection of Buildings Particularly in England," (Dept. of Scientific and Industrial Research, Special Report No. 27) HMSO, London, 1959.
- Kung, H. C., "Residential Sprinkler Protection Study," Factory Mutual Research Corporation Serial 22442, November 1975.
- Magee, R. S. and MacAlevy, R. F., III, "The Mechanism of Flame Spread," *J. Fire and Flammability*, 2, pp. 271-297, 1971.
- Magee, R. S. and Reitz, R. D., "Extinguishment of Radiation Augmented Plastic Fires by Water Sprays," Fifteenth Symposium (International) on Combustion, Combustion Institute, Pittsburgh, 1975, pp. 337-347.
- Maroni, W. F., "Rigid Cellular Wall Insulations," *Fire Journal*, Nov. 1972, p. 38.
- Parker, W. J. and Long, M. E., "Ignition, Heat Release, and Non-combustibility of Materials, ASTM STP 502, American Society for Testing and Materials, Philadelphia, 1972, pp. 135-151.

## BUILDINGS

- Reimschuessel, H. K., Shalaby, S. W. and Pearce, E. M., "On the Oxygen Index of Nylon 6," *J. Fire & Flammability*, 4, 299-308, 1973.
- Robertson, A. F., Gross, D. and Loftus, J., "A Method for Measuring Surface Flammability of Materials Using a Radiant Energy Source," *Proc. Am. Soc. Testing and Materials*, 56, pp. 1437-1453, 1956.
- Routley, A. F., "The Development of the Oxygen Index Concept for the Assessment of the Flammability Characteristics of Materials," Central Dockyard Laboratory, HM Naval Base, Portsmouth, Report No. 573, 1973.
- Smith, E. E., "Heat Release Rate of Building Materials,"
- Steiner, A. J., "Method of Fire Hazard Classification of Building Materials," *ASTM Bulletin* No. 121, pp. 19-21, 1943.
- Stuetz, D. E., Barnes, B. P., DiEdwardo, A. and Zitomer, F., "Flammability as an Intrinsic Property of Polymers," Presented at the 42nd TRI Annual Research and Technology Conference, New York City, April 5-7, 1972.
- Tewarson, A., "Flammability of Polymers and Organic Liquids - Part I. Burning Intensity," Factory Mutual Research Corporation Report RC 75-T-6, February 1975.
- Thomson, Norman J. and Cousins, E. W., "The FM Construction Materials Calorimeter, *NFPA Quarterly*, 52, No. 3, pp. 186-96, Jan. 1959.
- Williamson, R. B. and Baron, F. M., "A Corner Fire Test to Simulate Residential Fires," *J. of Fire and Flammability*, Vol. 4, April 1973, p. 99.
- Williamson, R. B., Department of Civil Engineering, University of California, Berkeley, Private Communication, 1976.

## CHAPTER 6

### ELEMENTS OF FIRE SAFETY AND DESIGN

#### 6.1 Introduction

Fire protection engineers are rapidly improving analytical techniques that will allow a designer to better anticipate and evaluate the fire safety of a building. The approach builds on the current systems of building design with their strong historical ties and yet it can be used in relatively new fields like aircraft design. A format that exhibits this characteristic has four essential parts:

- A. OBJECTIVES for fire safety — simply stated.
- B. CRITERIA to meet the objectives — defined in a rational manner.
- C. TESTS — to determine compliance of given designs to the criteria.
- D. RESEARCH — as required to improve the capability to meet the criteria.

The above format is meant to be general in nature. By necessity fire protection codes and standards must be more specific; however, detailed criteria and test methods related back to a set of valid objectives will establish the basis for rational design specification standards.

Fire safety objectives will usually involve some combination of: (1) prevention of death or injury; (2) prevention of property loss; and (3) maintaining continuity of operations. These objectives need to be measurable.

These objectives may be addressed by establishing one or more of the following building criteria:

1. *Prevention of Ignition*: The frequency of unwanted fires is controlled before ignition. The probability of fire initiation is kept below some assigned value.

2. *Retarding Fire Propagation Within Interior Spaces*: The rate of fire spread through any interior space from a given source of ignition should be slow enough to give a high, pre-assigned probability of either evacuation or control.

3. *Containment of Fire in Interior Spaces*: The walls, floors, ceiling, and other building elements should be able to *contain* the fire for a period of time sufficient to permit evacuation of occupants. Where evacuation is not feasible, the principal objective is to allow a period for firefighting and damage control while the occupants remain in the building.

4. *Maintaining Structural Integrity*: The building should retain its structural integrity for enough time to permit evacuation. If evacuation is not feasible, the building should retain its integrity long enough for firefighters to bring the fire under control. A more difficult criterion would be that the structural integrity is sufficient to be retained through complete burnout of a fraction of the building. This latter criterion would be valuable in an earthquake or air raid situation where firefighting was restricted.

5. *Detection and Suppression*: The building should be provided with equipment

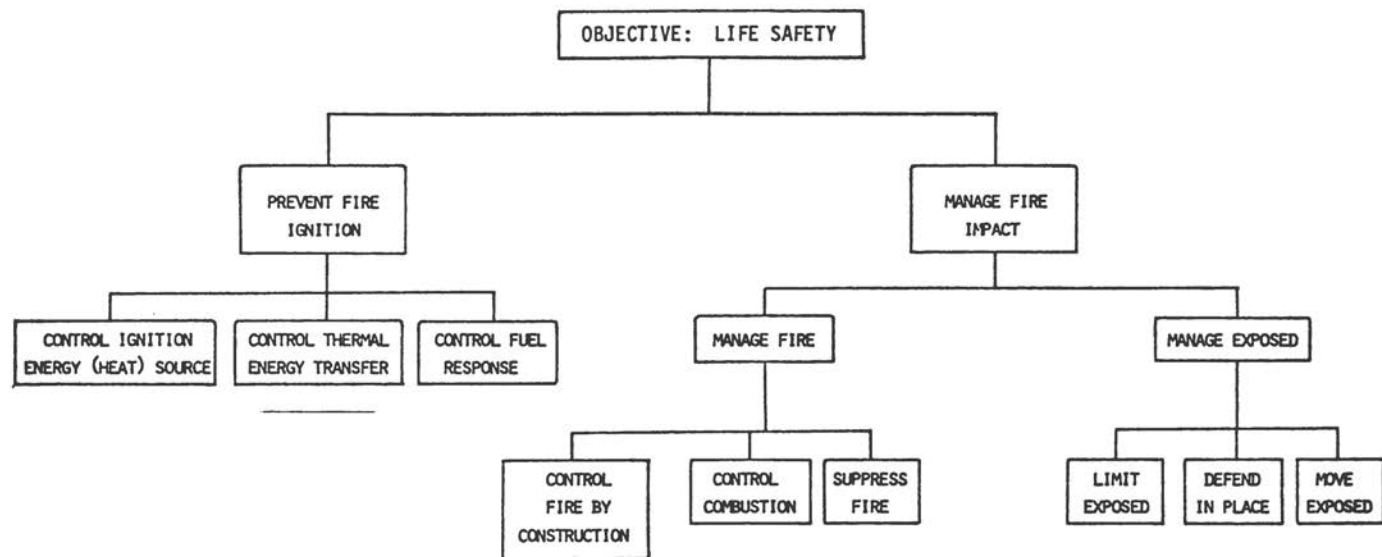

Figure 6.1. Building Criteria – Organization Chart.

for reliable timely detection and, in certain cases, either manual or automatic suppression systems with demonstrated high probability of effectiveness.

6. *Toxic Threat of Products of Combustion:* The building contents and construction should minimize materials that produce excessive amounts of smoke or toxic gases that would threaten the life of occupants.

7. *Movement and Safety of Occupants and Firemen:* The safe emergency movement of building occupants should be planned for any conceivable fire in the structure. In very tall buildings a communications system may be required to direct the movement of occupants to safe areas of refuge; also emergency elevators for both fire service and evacuation use may be required. Some control is an important aspect in tall buildings.

A way of illustrating the logical organization of these criteria is shown in Figure 6.1. Assume one of the objectives listed above is placed at the head of Figure 6.1. Then one considers the possible alternate means of reaching the objective. It is obvious from Figure 6.1 that a variety of means is available to achieve the objective of life safety from fire, such as: prevent ignition, suppress fire, control fire by construction, move exposed, etc. The reliability of a successful design with its attendant redundancies must then be evaluated.

The present state-of-the-art does not provide the quantitative reliability information needed to calculate the cost-effectiveness of a proposed design. Fire protection engineers traditionally have judged the worth of a design based on general experience, component test results, full-scale fire tests when available, and very limited statistical data. There is a strong need to increase this knowledge base. As the knowledge base increases, the use of a quantitative design approach to fire safety in buildings can be expected to increase.

## 6.2 A Systems Approach to Design

In all its aspects, a building provides the ingredients of an operating system. Functionally the building provides shelter, environmental control and quarters for many facets of daily habitation, including work areas, storage areas, recreational facilities, possible sleeping facilities, and sanitation facilities. Because of the many functions that the building must provide, and the different age levels, training, and capabilities of the individuals utilizing the building, a systematic approach to fire safety design is essential.

### 6.2.1 Prevent Fire Ignition

One view of the prevention of ignition is that it is simply the separation of heat energy sources from potential fire load. Heat energy sources may include electrical appliances, building heaters, gas and electric stoves, oily rags, and especially cigarettes and matches. Most equipment sources of ignition are governed by local, regional or national codes. Beyond this, the isolation of the unit from its surrounding area can be accomplished by the judicious use of fire resistant material. These



materials can take the form of metals, glass, ceramic tiles, asbestos or other non-combustible materials commensurate with the functional use of the area. Heat energy sources which are not an integral part of the building system are obviously much more difficult to control.

### 6.2.1.1 Control Ignition Energy Source

Preventing unwanted fire ignition concerns the elimination of ignition energy sources or control of the rate of heat release from such sources to adjacent combustibles.

Electricity is a general source of energy in buildings. Electrical systems which will favor a safe environment are ones that are designed and constructed in accordance with the National Fire Protection Association's National Electrical Code #70. However, due to the use of improper materials or improper workmanship electrical fires do occur. Surveys indicate that wiring is the source of ignition for 8 percent of household fires (U.S. Department of Commerce 1976).

Ignition energy sources such as furnaces, water heaters, cooking ranges and electrical equipment are designed to meet certain safety standards published by Underwriters Laboratories, American Gas Association and National Fire Protection Association. Most of these standards are voluntary, but become mandatory when they are incorporated into local or State codes.

Heat producing appliances are designed with enclosures to limit the rate of energy release to adjacent combustible materials such as wood. Materials with an ignition point less than wood may be a fire hazard when used adjacent to these appliances.

Appliances (cooking units, hair dryers, toasters, portable heaters, etc.) account for 62 percent of the ignition sources in household fires (U.S. Department of Commerce 1976). Of all household fires that involve appliances, more than half involve cooking.

Very common ignition sources are smoking materials and matches. Respectively, in household fires they rank 7 percent and 4 percent as ignition sources in unwanted fires (U.S. Department of Commerce 1976). However, smoking materials rank high as the cause of death, 27 percent, which is over five times other ignition sources. It is apparent that the majority of fire ignition sources can be traced to human carelessness.

Control of careless use of ignition sources can only be attained by educating the user; e.g., not to smoke in bed or not to leave a range unattended while cooking ignitable foods. However, these ignition sources might be further controlled by redesign; e.g., a cigarette can be designed to self-extinguish when not being puffed before it ignites bedding or furnishing materials. Alternatively, bedding or seating material could be redesigned to resist cigarette ignition, as in the previously noted recent mattress standard.

### 6.2.1.2 Control Thermal Energy Transfer

In an environment containing fuels and ignition sources, preventive steps must be taken to control heat transfer from potential ignition sources to fuels. This may be accomplished by: (a) preventing movement of the ignition source to a location where ignition can occur (through the interposition of either a material barrier or a space), (b) achieving safe rate at which the fuel receives heat from the ignition source, by controlling all the transfer mechanisms (conduction, convection, and radiation), and (c) preventing the movement of the fuel to a location where ignition can result (through the interposition of either a material barrier or space).

Typical examples of building construction safeguards relative to thermal energy transfer are contained in the following list of the National Fire Protection Association's standards:

- 31 Installation of Oil Burning Equipment
- 54 Installation of Gas Appliances and Gas Piping
- 70 National Electrical Code
- 70A Dwelling Electrical Code
- 82 Incinerators and Rubbish Handling
- 85 Prevention of Furnace Explosions in Fuel Oil and Natural Gas-Fired Watertube Boiler-Furnaces with One Burner
- 85B Prevention of Furnace Explosions in Natural Gas-Fired Multiple Burner Boiler-Furnaces
- 85D Prevention of Furnace Explosions in Fuel Oil-Fired Multiple Burner Boiler-Furnaces
- 85E Prevention of Furnace Explosions in Pulverized Coal-Fired Multiple Burner Boiler-Furnaces
- 86A Ovens and Furnaces, Design, Location and Equipment
- 86B Industrial Furnaces for Processing Materials, Design, Location and Equipment
- 86C Industrial Furnaces Using a Special Processing Atmosphere
- 89M Clearances for Heat Producing Appliances
- 90B Installation of Warm Air Heating and Air Conditioning Systems
- 96 Installation of Equipment for the Removal of Smoke and Grease-Laden Vapors from Commercial Cooking Equipment
- 211 Fire-Safe Construction and Installation of Chimneys, Fire-Places and Vents
- 802 Fire Protection Practice for Nuclear Reactors

Generally, these standards aim at (a) Maintaining exterior surfaces of heat producing equipment and appurtenances to a temperature below 160°F by insulating the equipment enclosure or by ventilating the surrounding space, and (b) Arranging safety control devices such as shutoff fuel valves to close in the event of failure of combustion air, excessive combustion air pressure, flame failure, excessive

temperature, excessive fuel pressure, too low fuel pressure and failure of electric current.

These standards are generally mandated by City, County, State or Federal codes or regulations. Building codes require heat producing equipment and safety devices to be tested and listed by an independent testing laboratory, which may in turn establish criteria governing the construction of this equipment.

### **6.2.1.3 Control Fuel**

One means of accomplishing the element of fire safety design is to eliminate all fuel. This is not a very practical solution for many environments. A more feasible approach is to specify the nature, quantity, and geometric arrangement of fuels to be permitted. It is often practical to provide the fuel with an inert coating or to store it in an inert container. In some cases chemical modifications (fire retardants) are sufficient. The humidity of the environment may influence the ignitability, and thereby provide a route for control. Substantial quantities of combustibles, which may be found in storage areas of a building, should be isolated by compartmentation.

### **6.2.2 Manage Fire**

Most fires begin as small fires and in their early stages are easily controlled. The noxious products are minimal and not yet widely distributed. The earlier that a fire can be detected, the better are the chances of escape for persons in potential danger and the sooner suppression methods can be brought to bear on the fire.

#### **6.2.2.1 Control Fire By Construction**

Control of fire by construction is the traditional approach used in most building codes. Control is provided by the degree of fire endurance or fire resistance of building construction components (columns, walls, beams, floors, etc.). The degree of fire endurance further varies in relation to the quantity of combustible material normally found in the occupancy for which the building is designed and to the height of the building. Tall buildings are constructed of noncombustible components having a high degree of fire endurance; whereas single family dwellings are usually constructed of combustible components having very low fire endurance. The fire control rationale for this is that a dwelling fire may be readily attacked from the ground level whereas tall buildings require considerably more time to evacuate. Structural elements of tall buildings are designed to remain in place during a fire even when the furnishings and other combustible contents are completely consumed by the fire. The degree of fire endurance required is established by building codes based on empirical determinations. Fire resistance of a building assembly is determined by ASTM E119, in hours of protection. The duration of the test fire is related to the "fire load" (weight of combustibles per sq. ft. of floor area), i.e., one hour endurance corresponds to a fire load of 10 lb./sq. ft. of

combustible material having a calorific value of 8,000 Btu/lb.

In a fire, structural integrity alone does not assure safety of occupants. The movement of the fire needs to be controlled to give the occupants time to escape and time for firefighters to reduce property loss. This is accomplished by dividing the building into fire resistive compartments designed to contain the fire within a small area. In a residential multifamily building this compartment may be as small as an apartment. The movement of fire is further controlled in an apartment by the rate of flame spread across the surface of walls, ceiling and floors. Egress routes in tall buildings such as corridors and exit stairways are designed with enclosures (floor/ceilings and walls) of high fire endurance and with surfaces of low flame spread. Several test methods are available for classifying materials as to their surface flame spread flammability; the most widely used is ASTM E 84-Surface Burning Characteristics of Building Materials. (The drawbacks of this test method were discussed in the previous chapter).

Some building mechanical components that control fire movement by containment are doors with closers which may be held open by a device that will release upon activation of a smoke detector, or fire dampers in air handling ducts that pierce fire resistive constructions.

The possibility of fire spread from building to building is reduced by providing a safe separation distance relative to type of exterior wall, type of windows (protective or nonprotective), window area and fuel loading (light, moderate or severe). Building-to-building spread of fire is generally due to radiative heat transfer. NFPA 80A depicts a geometric method of determining safe building separation distances based on empirical findings. However, most building codes provide prescriptive requirements according to construction types and occupancies.

Combustion products can be more hazardous than the heat from the fire in tall buildings. A small fire on the second floor of a tall building may completely fill the upper floors with smoke and toxic gases even when the fire is confined to the second floor. This is caused by the stack or flue effect in tall buildings. Smoke movement in tall buildings is still a subject of research, but mechanically induced air pressure systems have had some success by positive pressurization of stairwells, by providing 100 percent exhaust to the outside of the fire floor or area, and with the core of the building receiving a 100 percent fresh-air supply.

One effective method of smoke and heat control is to vent the fire to the outside. This is most efficient in one story buildings with openings in the roof that open automatically in the event of a fire. The venting not only retards the horizontal spread of fire by release of heat to the outside but it also allows immediate access to firefighters.

#### **6.2.2.2 Control Combustion**

Control of fire by retarding the combustion process is not widely practiced at present. It is conceived that this method of fire management is accomplished by

controlling the availability of ventilation, humidity or oxygen. An example would be locating an automatic roof vent directly above a likely fire source. Another example would be shutting off the air supply to a fire in a windowless room by closing the door. This not only tends to smother the fire but it also confines the toxic products and smoke to the room of origin. As noted earlier, the door could be closed automatically by a suitable fire sensor.

### 6.2.2.3 Detection

In the present state-of-the-art of detection technology, fire detection can be achieved within milliseconds of fire inception. It is possible, though not always cost effective, to provide nearly any level of response time desired (Custer and Bright 1974).

Detection is the essential preliminary step to either moving out the exposed people or suppressing the fire (Fire Detection for Life Safety 1977). Time is an important factor. Time is needed to alert the occupants and time is needed for them to reach an area of refuge. Throughout this period it is essential that an escape route be passable. Where the risk to life is minimal and property loss reduction is the consideration, longer detection times are often tolerated for the sake of minimizing needless alarms.

Model building codes and many state and local jurisdictions are requiring that each sleeping area be protected by a minimum of one smoke detector in each new dwelling unit of the multifamily and one- and two-family types. A study by McGuire and Roscoe (1962) of the circumstances surrounding 342 dwelling fire deaths in Ontario, Canada, indicated that the use of smoke detectors could have resulted in a 41 percent saving of life; the use of thermal detectors could save 8 percent. During certain hours of sleep, some people are not awakened by the smell of smoke; this accounts for the larger number of deaths in this time period.

The common detection devices are listed below. As detectors go up on the scale of speed of response, they also generally become more sensitive to normal environmental conditions. Without proper care in design, installation and maintenance, an unsatisfactory, false-alarm-prone system can result.

*Fixed Temperature:* These detectors operate when they are heated to specific temperature. They commonly employ bi-metal thermostats, fusible elements, or liquid-containing glass bulbs. To be effective, the detector should be located above and near any potential source of fire. Even then the fire may be well under way before detection occurs.

*Rate-of-Rise:* These detectors sense rapidly changing temperature conditions. Their speed of response is a function of the rate-of-temperature-rise. They typically work in the fifteen to twenty degree Fahrenheit per minute range. They can also be equipped with fixed-temperature detector elements. These detectors employ a pneumatic principle that converts pressure to mechanical action by a flexible diaphragm.

*Ionization Type:* The basic detection mechanism of an ionization detector consists of an alpha or beta radiation source in a chamber containing positive and negative electrodes. Alpha radiation sources are commonly Americium 241 or Radium 226. Nickel 63 is used as a beta source. The radiation in the chamber ionizes the oxygen and nitrogen molecules in the air between electrodes, causing a small current to flow when voltage is applied. When aerosols (smoke particles) enter the chamber, they reduce the mobility of the ions, thereby reducing the current flow. This triggers an alarm at a predetermined level of aerosol in the chamber. False alarms can be triggered by the presence of cooking fumes in kitchens.

*Photoelectric Type:* These detectors utilize a light source, a collimating lens system, and photosensitive cell offset in a dark chamber. The presence of an aerosol (smoke) scatters the light and the light is reflected into the photocell/relay assembly which triggers the alarm mechanism. Manufacturers are converting from the use of incandescent bulbs which had to be replaced every three to five years to light-emitting diodes which provide a reliable long-lasting source of illumination with low current requirement.

*Solid State Type:* Originally developed as a gas leak detector, the operating element utilizes a heated semiconductor surface. These detectors are reported to fail to respond rapidly to certain types of fires, and their adequacy as fire detectors has not been fully established. False alarm problems exist.

*Resistance — Bridge Type:* The sensing element consists of a glass plate on which is deposited a high resistance grid. When the grid is exposed to products of combustion, the resistance decreases due to absorption of materials on its surface. This change is used to initiate an alarm. These detectors have had difficulty with false alarms from moisture and airborne contaminants.

*Infra-Red Detectors:* These sense the infra-red energy of flame and operate only when there is an accompanying flicker. The flicker of the flame modulates the infra-red. This detector is blind to steady infra-red. It must be mounted within line-of-sight of the fire.

*Ultra-Violet Detectors:* Ultra-violet energy is in the frequency range just above that of visible light. Flames give off significant amounts of ultra-violet energy. Other heat sources do not generally give out much ultra-violet energy; however, sunlight does. Line-of-sight mounting would be required.

The selection of detection devices depends upon the type of fire anticipated, the environmental considerations, ultimate uses of the signal and cost-effectiveness. Signals are typically used to initiate evacuation, alert firefighting personnel, initiate extinguishing systems, to control elevators or air handling systems, close fire doors, etc.

Full-scale fire tests conducted in a variety of abandoned residential single family dwellings indicate that smoke detectors (photoelectric or ionization types) should be located at the head of each stairway, outside every sleeping area, and on every level of a multi-level dwelling. Smoke detector sensitivity of 1 percent obscuration

per foot allowed adequate escape time in those tests. Fixed temperature or rate-of-rise heat detectors in the room of origin proved ineffective as an early fire warning device (Bukowski et al. 1976).

NFPA Standard No. 74 provides detailed information on recommended location of detectors in buildings.

#### 6.2.2.4 Suppress Fire

Once detected, a fire may be suppressed in any of three ways: (a) by personnel already on the scene; (b) by professional firefighters, with specialized equipment, who arrive later; or (c) automatically, usually by sprinklers.

If the fire is detected at an early stage, the first person on the scene may be able to control the fire by smothering, removing the burning object from the building, using small amounts of water, or using a portable extinguisher. However, if the fire has grown to a substantial size before discovery, such actions will usually be ineffective.

If the fire is too large for the discoverer to handle, then a further time lag of up to ten minutes (more in isolated locations) must occur until professional firefighters can arrive. If the growth rate of the fire is not too great, and if smoke has not obscured the ability to locate the fire in the interim, the professional firefighter can often control the fire shortly after arrival.

The paragraphs above contain a series of "ifs." Those fires which are discovered too late or grow too fast will do substantial damage before being controlled. (Fire growth is often observed to follow an exponential law; doubling every 30 seconds has been observed). Accordingly, suppression by manual action, while highly effective in the great majority of cases, will not always be fast enough.

Automatic suppression systems provide an optional means for rapid control of fires. These systems apply an agent, usually water, as soon as they detect a fire, usually by a thermally sensitive element mounted near the ceiling. The most common suppression system is the automatic water sprinkler, first introduced 100 years ago.

Automatic systems for releasing dry chemicals, halogenated hydrocarbon gases and liquids, or carbon dioxide are also available, but their use is primarily limited to special situations because of cost and the "one-shot" nature of the application. There is an asphyxiation hazard from carbon dioxide and the vapors of halogenated hydrocarbon gases and liquids. (See Volume 3 of this report).

The automatic sprinkler, connected to a substantial water supply, has been proved to be highly effective in controlling fires. It is estimated that approximately seven million sprinklers were installed in the United States in 1975, primarily in industrial and commercial buildings. Building codes in a minority of cities and states require automatic sprinklers in specific types of buildings, such as nursing homes, restaurants, auditoriums, retail sales buildings, high-rise buildings, etc. Other building codes permit choices between sprinklers and increased compartmentation



in high-rise buildings. The great majority of existing buildings in the United States are not sprinklered. Even for nursing homes, where perhaps the strongest case can be made for sprinklers, it was recently stated by the General Accounting Office that less than half are sprinklered. Sprinklers are essentially non-existent in single-family residences; National Fire Protection Association Standard 13-D, pertaining to residential sprinklers, was first issued in 1976.

The universal use of sprinklers has been opposed by three arguments: (1) cost; (2) possible water damage; (3) slowness of response, especially to a smoldering fire.

The cost is primarily that of installing the piping system. An installation of threaded steel pipe, conforming to industrial standards, currently costs about one dollar per square foot of protected space. A less rugged system using flexible (copper or plastic) tubing and much smaller water flow rates might be adequate for residential use at much lower cost, but such a system has not yet been completely evaluated for operating effectiveness. Research is necessary to determine minimum water rates and maximum sprinkler spacing, to design a truly minimum-cost system of predictable effectiveness for the residential home.

The water-damage argument applies especially to buildings containing electrical equipment (computer centers) or to libraries or record-storage areas. However, insurance company experience shows that the cost of drying out and reclaiming such items is far less than the additional fire damage to be expected in the absence of an automatic suppression system.

It is known that a smoldering fire often will not generate enough heat to activate a thermally responding sprinkler, but may generate lethal quantities of toxic smoke. Also, if a flaming fire is spreading across a bed containing an immobile occupant, a sprinkler in the room may not respond before severe burns occur (NBS Technical Note 836, "Detector Actuated Automatic Sprinkler System — A Preliminary Investigation"). The sprinkler however would confine the fire to the room of origin in this case.

Standards for acceptable sprinkler protection of commercial and industrial properties have been developed and are continually being refined by insurance companies, e.g., Factory Mutual. Refinement comes partially from full-scale fire tests and partially from loss experience. In a few cases, modeling experiments have been helpful. However, it must be recognized that more information is available on industrial and commercial combustibles than on residential combustibles.

To illustrate a difference in the burning of wood versus expanded polystyrene under sprinklers, the following data from Factory Mutual Research Corporation are quoted:

*Common Conditions:* Pallets made of either wood or expanded polystyrene, stacked six feet high, (9 stack in square arrangements), with sprinkler density of 0.3 gal/min-square foot, top of array 9-feet below ceiling, 165°F sprinkler links spaced 10' X 10' on ceiling.

*Results — Wood:* Seven sprinklers opened; maximum ceiling temperature above



fire was 565° F. The fire spread was controlled.

*Results — Polystyrene:* 59 sprinklers opened; maximum ceiling temperature above fire was 2100° F. Fire burned intensely until melting caused collapse of the pile.

For very intense fires, especially under a high ceiling, the upward velocity of the fire plume prevents penetration of water droplets. By modifying sprinkler design to increase production of larger drops, penetration can be dramatically improved. By operating sprinklers above a closely controlled fire plume and measuring water arrival at floor level, one can measure penetration efficiency as a function of sprinkler parameters. Factory Mutual Research Corporation is currently attempting to develop sprinkler standards based on these considerations.

One of the most severe fire challenges known, other than flammable liquids or gases, is that of plastic commodities which are stored in factories, warehouses or retail outlets, in configurations reaching substantial heights. The maximum tolerable height of stored commodities under ceiling sprinklers has been empirically determined by Dean (1975) for various commodities. This height is much less for plastics than for cellulosic materials. Among various plastics, Dean found trends as follows:

polystyrene — vigorous burning  
polyethylene, polypropylene — intermediate  
polyvinyl chloride — relatively mild

However, he noted that exceptions to such rankings commonly exist because of effects of detailed geometry, packaging material, or polymer additives, especially plasticizers.

It may be remarked that it is possible to store polymeric materials safely at greater heights than those permitted under ceiling sprinklers by installing additional sprinklers at intermediate levels, preferably below horizontal barriers. Alternatively, a development program is underway at Factory Mutual Research Corporation to use unconventional sprinkler heads of greater penetrating power at ceiling level. Use of such heads would permit relaxation of either the storage height requirement or total water demand.

### 6.2.3 Manage "Exposed"

The fire impact can be managed either by managing the fire or by managing the "exposed" or both. The "exposed" may be people, property, or functions depending on the design aspects being considered. The "Manage Exposed" activity can be successful either by limiting, defending, or moving the exposed (Fire Protection Handbook 1976).

In managing materials of value that may be exposed to a fire, considerations should be given to (a) determining an acceptable risk of total loss and separating this into fire areas, (b) putting these materials in an area that is inert or can be defended by fire extinguishing systems, (c) providing a warning system and manu-

ally suppressing the fire, or (d) separating material into acceptable fuel packages by enough space so that the fire will self-terminate.

Managing people exposed to fire is a different matter and it is difficult to establish an acceptable risk. How much is a life worth? The answer will help make important decisions in the providing of defence against a fire in place (warning and manually or automatically suppress the fire) or providing means of escape (warning and safe egress routes) all under economic restraints. If a residential building were to incorporate every conceivable fire safety measure, only the very affluent would be in a position to use it. Society must make decisions on trade-offs between fire safety measures and comfort, livability, visual appeal and luxurious surroundings.

### 6.2.3.1 Limit Amount of "Exposed"

Exclusively limiting the exposure achieves success only to the extent that the maximum amount of the "exposed" (i.e., people, contents, structure) does not exceed the amount described by the fire safety objectives. This element of design assumes that if a fire occurs and the contents of the building or a certain part of a building is destroyed, this is an acceptable risk. This has been the case of the single family dwelling.

The whole house and everything in it was deemed "dispensable" to a high degree. But, developments (such as early warning fire detectors) suggest that society will seek significantly reduced levels of life loss.

This element of design probably would be better applied to a warehouse that contains contents which are dispensable. These perishable items, not "dispensable" are divided into lots that are considered an acceptable risk and placed in separate fire areas.

### 6.2.3.2 Defend In Place

This approach has to do with protection of the "exposed" by (a) preventing intrusion from fire products evolving outside the space; (b) protection from a fire within the space containing the "exposed;" and (c) assurance that the environment containing the "exposed" remains tolerable to the "exposed" whether that is a person, a commodity, or a facility with utilitarian value. For example, valuable computers are housed in a space that is protected from outside fires by walls, floors, and doors with high fire resistance and protected from fires within the space by fire detectors that trigger fire extinguishing systems such as a halon gas system.

### 6.2.3.3 Move "Exposed"

Moving "exposed" generally involves people to be moved or people to do the moving. This involves communication components, structural and mechanical components, and assuring the completeness of the system. All of these interface directly with the involved people. A complete pre-fire analysis and instruction to those responsible for moving the "exposed" — either themselves, others, or property is

required. In addition, suitable facilities must be furnished to provide a complete, protected path and a safe destination through which and to which the "exposed" can be moved.

Having provided instructions and safe facilities, the system then becomes dependent on at least three other elements — a fire, timely detection of the fire and post-ignition communications, including signalling the need.

An example of what has been discussed would be a hospital incorporating trained nurses, early fire warning devices in patient rooms, protective construction that encloses corridors, and a safe refuge area.

### 6.3 Future Elements in Design

Much consideration has been given to the fire hazards in present-day dwellings and industrial and custodial buildings. The questions that now must be answered are:

- How should future structures be designed to take advantage of what has been learned at such great cost?
- Is it possible to bring together all of these factors so that the constantly rising toll of life and property will be reversed? Whatever is projected to improve the situation must consider the following factors; the increasing use of polymeric materials in construction and furnishings, the rising costs of labor and materials, trends toward multiple high-rise dwellings and their attendant complexities, and the slowness with which legislation for improvement is adopted or present regulations updated.

This section will present some of the future elements that must be considered to make the buildings of tomorrow significantly more fire-safe. If only part of these concepts are adopted, the results should appear as welcome improvements in fire statistics.

#### 6.3.1 Materials

In a given potential fire situation, if that material which is most easily ignitable and which contributes most to the heat load is removed or replaced by another material which is more fire-resistant, then the fire-safety of the system is improved disproportionately to the weight ratio of that material in the system. In other words, the removal or replacement of the most hazardous material produces a beneficial effect that is significantly greater than the relative proportional presence of the material in the system.

The increasing general use of plastics in building construction and in building furnishings as well as the increased substitution of plastics for metals and ceramics makes it imperative that each new material be evaluated with great care to ascertain that it does not add to the ease of ignitability of other materials already present. This can be done in some measure by requiring flammability characteristics to conform to rigid specifications it can also be done by minimizing the amount of

plastic used, for example, the use of thin plastic-coated metal-based structures rather than total plastic or fiber-reinforced plastics. Permanence of fire retardants in plastics should also be required.

The potential flammability, smoke, and toxic gas evolution of each new material that is marketed must be considered. Industry should be encouraged to do the necessary research and development to discover new polymer composites or flame retardants that could be used to maximize fire-safety for the life of the structure that uses the material.

New materials appear on the market almost daily; it is impossible for an individual to learn all their properties, let alone evaluate them relative to his needs. A possible solution to this problem is the use of a single computerized data bank which would be maintained and continually updated. Using presently available technology, an individual would be able to have access to the data bank by the use of a proper terminal. The pertinent material data could be stored by usage category and would include the names of the manufacturers, followed by the pertinent characteristics: physical and mechanical properties, durability, maintainability, flammability, smoke and toxicity properties, all according to standard test procedures. Cost information and regulations regarding use would also be given. In preventing this data, the information in any category can be given in ascending or descending order of any of the characteristics. This, in effect, gives an order of merit. The user thus would have available to him most of the information needed to design his structure or select his furnishings.

### 6.3.2 Structures

Aesthetics and serviceability are generally the paramount operators in the design of a dwelling or other building. These are followed by comfort. Safety is generally a last consideration. With the current societal awareness of fire and other safety hazards, designers, architects and engineers now have an opportunity to reverse this order with safety of the occupants as the primary consideration.

Once the structure has been designed to maximize safety (structural integrity, ease of egress, etc.), the architect has the opportunity to select the materials of construction, which he could do with greater assurance if he had the assistance of a computerized information data bank as discussed in the preceding section.

Since many fires originate from faulty or overloaded electrical wiring systems, future design calls for greater attention to be paid to this area. An electrical wiring system should be designed with the best of modern technology to anticipate heavier use with time, as predicted by past trends. The wiring system should resist overloads. It should be made difficult for amateurs to tamper with the wiring system.

The design of large multi-occupant buildings and especially tall buildings should include special ventilation features for control of smoke movement. Key needs are preservation of escape routes and isolation of smoke in the fire region from the rest of the building.

Construction regulations related to fire safety must be updated on a continuing basis.

### 6.3.3 Early Fire Detection

Much has been written on the subject of fire detectors and there are indeed many to choose from. The selection of the particular system will depend on many factors, and guidelines have been developed to assist the architect. It is hoped that other states will follow the example of the few states which currently have laws requiring the inclusion of smoke detectors in new residential buildings. This regulation should be made retroactive to older buildings and extended to all buildings.

In addition, it may be possible to connect fire detectors into the local fire station. This would enable the fire departments to be alerted to fires in dwellings or buildings which are unoccupied at the time of the fire, or in which the occupants have been overcome by smoke inhalation.

### 6.3.4 Fire Suppression

Future design for fire suppression would extend the requirement for water sprinklers far beyond present requirements. A few states require all buildings over 70 feet in height to be sprinklered. This is related to the feasible height for fire aerial ladder apparatus. Such a rule should be adopted for all states. A strong argument can be made for sprinklering all places of public assembly, especially restaurants, bars, and nightclubs, as well as hotels and custodial facilities. The question of whether private residences can feasibly be sprinklered is currently the subject of study by Factory Mutual Research Corporation, the National Fire Prevention and Control Administration, and others.

## 6.4 Conclusions and Recommendations

### *Conclusions:*

1. The knowledge base provided to fire protection specialists and building designers needs to be greatly increased. Significant areas of required augmentation include component test results, full-scale tests, and statistical data.
2. Fire protection specialists and building designers have traditionally judged the worth of a design based on general experience, component test results, some full-scale tests and limited statistical data rather than on a systems analysis.
3. Statistics indicate that the majority of building fire ignitions are due to human carelessness.
4. Building construction safeguards are available through NFPA Standards for a wide spectrum of construction disciplines.
5. The earlier in its development that a fire can be detected, the better are the chances of (a) escape for persons in potential danger and (b) suppressing the fire before serious damage is incurred.
6. Most building codes emphasize the traditional approach of controlling the fire by construction.
7. Combustion products can be more of a hazard than the heat from the fire, especially in a tall building; upper floors may be filled with smoke and toxic

## ELEMENTS OF FIRE SAFETY AND DESIGN

gases even when the fire is contained to a lower floor.

8. Full-scale fire tests indicate that smoke detectors should be located at the head of each stairway, outside every living area and on every level of a multi-level dwelling.
9. Fire growth is often observed to follow an exponential law; accordingly, suppression, especially by manual action, may not always be initiated early enough to be effective.

### *Recommendations:*

1. Increase the knowledge base provided by fire protection specialists and building designers through the performance of additional component tests, full-scale tests, and tabulation of statistical data.
2. Judge the fire safety of building design from the perspective of a systems analysis rather than from general personal experience aided by limited test and statistical data.
3. Provide a system for rapid communication of emergency instructions in all public buildings.
4. Modify the design of cigarettes so that they are not capable of igniting upholstered furniture and bedding materials.
5. Provide automatic elevator deactivators that will direct elevators to a safe floor level upon fire detector signal.
6. Provide automatic fire-actuated room door closing devices in health care facilities where room occupants are unable personally to initiate this action.
7. Provide ventilation systems in large buildings which are specifically designed for control of smoke movement.
8. Critically review the surfaces (floors, ceilings, walls) of all egress routes in buildings, i.e., corridors and stairwells, for fire-spread characteristics.
9. Continue research towards the development and evaluation of home sprinkler systems, looking to safety and economy.
10. Promote by educational campaigns, insurance incentives, etc., the installation of smoke detectors in existing residential buildings and require installation in new buildings.
11. Expand fire safety education efforts at the community level to provide citizen awareness of the problems and the necessary solutions.

### **References**

- Bukowski, R. W., Waterman, T. E. and Christian, W. J., "Detector Sensitivity and Siting Requirements for Dwellings," National Bureau of Standards, 1976.
- Commerce, U.S. Department of, "Highlights of the National Household Fire Survey," National Fire Prevention and Control Administration, U.S. Department of Commerce, 1976.
- Custer, Richard, L. P. and Bright, Richard G., "Fire Detection: The State-of-the-Art," National Bureau of Standards, Technical Note 839, 1974.
- Dean, R. K., "Stored Plastics Test Program," Journal of Fire and Flammability, Consumer Product Flammability Supplement, Vol. 2, pp. 248-313, December 1975.
- National Academy of Sciences, "Fire Detection for Life Safety (a symposium, March 1975), ISBN 0-309-02600-8, pp. 245.
- National Fire Prevention Association, Fire Protection Handbook, 14th Edition, NFPA, Boston, Mass., January 1976.

## CHAPTER 7

### REVIEW OF MAJOR POLYMERIC MATERIAL FIRE HAZARDS IN BUILDINGS

#### 7.1 Introduction

This chapter includes recapitulation of highlights to be found in other chapters and attempts to set priorities for selected conclusions and recommendations. The choice of material to include in this chapter is more subjective than the rest of the volume. The reader should be cognizant that additional hazard situations not mentioned in this chapter are discussed throughout the volume, and especially in Chapter 4.

#### 7.2 Seating and Bedding Items Containing Flexible Foam

The widespread use of flexible foam, primarily polyurethane, as a replacement for cotton in upholstered furniture and mattresses over the past decade is probably the single materials application of greatest concern from the viewpoint of life loss in building fires. The reasons are: (1) once flaming combustion is initiated in such an item, burning is very rapid; (2) the combustion characteristically produces heavy smoke and generally other toxicants in addition to carbon monoxide; (3) some polyurethane foams in combination with certain covering materials can sustain smoldering; (4) furnishings containing flexible foam may now be found in virtually every dwelling in the United States.

An effective step that could be taken to control the hazards of flexible foam, in the long run, would be to increase the resistance of these furnishing items to ignition by small ignition sources, especially cigarettes. The Federal government has already issued a mattress standard; a standard for upholstered furniture is under serious consideration at this time of writing. Current information suggests that present technology is adequate to find cost-effective constructions which would satisfy such a standard. However, it has been argued that there would be a substantial cost of testing and enforcement. Also, many non-smoking households object to paying any significant premium for cigarette-resistant furniture.

Furthermore, it would be a number of decades before all the present upholstered furniture and mattresses could be replaced by ignition-resistant items, and in the interim, thousands of lives would be lost from fires involving these items. This life loss might be minimized by a more widespread use of smoke detectors, especially in residences<sup>1</sup>.

---

<sup>1</sup> Good smoke detectors presently cost about \$30.00 retail and about half as much if purchased in large wholesale quantities (as by local government).



Another approach to dealing with this hazard might be to modify cigarettes so that they self-extinguish more readily. This is not likely to appeal to smokers; but, it has three advantages: (1) it would start saving lives immediately (rather than requiring decades to replace furniture); (2) it appears to be technologically quite easy to accomplish; and (3) it puts the burden on the potential fire initiator rather than on the non-smoking segment of the public.

More widespread use of automatic sprinkler systems, particularly in high occupancy buildings, would have a powerful effect in preventing multiple casualties from fires starting in seating or bedding, even if the sprinklers were not to actuate fast enough to save the initial victim who perhaps fell asleep while smoking. The wisdom of providing sprinklers in every residence should be given further study.

It must be noted that even after seating and bedding are made resistant to small ignition sources, they may still be vulnerable to larger ignition sources such as a wastebasket full of trash. Thus, other defenses such as smoke detectors and automatic sprinklers are still relevant.

### 7.3 Interior Finish Materials

Interior walls, floors, and ceilings of buildings are often covered with combustible materials (paneling, carpets, vinyl wall coverings, ceiling tiles, etc.). Such materials are generally resistant to ignition by a small ignition source (with the exception of certain drapery materials) but, once a fire is established, they may make a major contribution to fire growth and particularly to fire propagation down corridors or in stairwells. Improper choice of interior finish materials is a major factor in fatal building fires; it ranks just behind flexible foam bedding and seating.

For quite some time, building codes have taken cognizance of the problem of interior finish materials. They have specified degrees of fire resistance for such materials as determined by test methods, such as ASTM E 84. However, this approach, while helpful, is not completely adequate, for two reasons. In the first place, the present test methods have been frequently found to be unreliable measures of hazard. (See Chapter 5). In the second place, there is no effective way of applying building codes to residents of private dwellings who buy and install finish materials themselves.

Inadequate test methods should be the subject for research. Validating test methods in terms of actual or realistic fires is a high priority need. These are difficult technical problems and will require systematic long-range study, utilizing, *inter alia*, the methods of fire dynamics (see Volume 4).

Or, one might ban the *manufacture and sale* of high-hazard interior finish materials. In most cases this approach might be very hard to justify, because the hazard depends not only on the intrinsic properties of the materials but also on the quantities used in any one place and the ways in which they are used. A given material may be highly hazardous in one application and negligibly so in another. Important hazard factors are: the presence or absence of a backing material which may act as a

heat sink; the exposed surface area in relation to room size; vertical versus horizontal configuration; possibility of radiant interchange between two or more surfaces; presence or absence of automatic sprinklers; degree of mobility of the occupants.

Labeling of interior finish products to warn the public of hazard when products are used in certain ways, combined with public education, would be desirable to minimize fire hazard.

### 7.4 Structural Foam Furniture

Many furniture items such as tables, cabinets, chests, bed headboards, bookcases, etc., which have traditionally been made of wood, are now being made of dense rigid foamed plastics, predominantly polystyrene, with simulated wood grain, so that the user may be unaware that substitution has occurred.

Such items are ignitable by a small ignition source much more readily than wood. When burning, they melt and drip, while wood chars. They burn much more rapidly than wood and liberate much more heat per unit of mass (see Volume 1). The smoke produced during combustion of polystyrene items is very much denser than that from a wood fire. In summary, the structural foamed polystyrene items are much more flammable than the wood furniture items they replace.

As a first step, the use of structural foam furniture for certain obviously unsuitable applications should be controlled. These applications would include: cabinets over kitchen ranges (unless properly shielded), simulated wood mantles over fireplaces, baby cribs, furniture for hospitals or nursing homes. A perfect mechanism for control is not obvious. One factor which may restrain manufacturers from making inappropriate products is product liability.

Additionally, any product which looks like wood but is actually more flammable should be appropriately labeled.

Looking to the time when most rigid furniture items are made of structural foam plastics, it can be anticipated that building fires will certainly be more severe, unless cost-effective means of decreasing the hazard are discovered.

### 7.5 Insulation

The growing energy shortage is causing increasing use of insulating foams. It is now well established that use of *exposed* polyurethane or polystyrene foam is, in general, not acceptable. This is so regardless of fire retardant which may be present, because fire from another source can induce rapid propagation over the exposed surface. Properly covering insulation foams with an inert barrier is acceptable.

Unfortunately, it is not easy to get this information to the "do-it-yourselfer." Also, small contractors may be uninformed or unscrupulous. The problem here is how to spread the word. Perhaps it would be helpful if local fire services would validate the services offered by insulating contractors and particularly in areas where building codes are deficient. Appropriate labeling of styrene foam board is recommended.

A rapidly growing type of low-cost home insulation is ground waste-paper, e.g., newsprint, to which fire retardant has been added. There is evidence that it is difficult to control the quality of this locally produced item. Furthermore, it appears that after installation, the fire retardant may be leached out after a period of time. The hazards of quality control and leaching should be specifically investigated. Then, depending on results, either specifications and quality control methods should be upgraded or the product usage should be restricted or banned.

### 7.6 Mobile Homes

Mobile homes constitute about 20 percent of single-family homes built in the last 5 years; they deserve special consideration. A feature of their construction has been the use of thin plywood paneling unbacked by gypsum board, leading to rapid fire spread. The design and particularly the necessarily compact arrangement of components has led to a higher incidence of ignition by malfunctioning heating, cooling, and electrical equipment than is found in conventional homes.

Recent Department of Housing and Urban Development Construction and Safety Standards for mobile homes specify improvements in these aspects, and also require smoke detectors in each new mobile home. However, a hazard exists in the millions of mobile homes built prior to introduction of these upgraded standards.

New uses of polymeric materials continuously appear in mobile homes, usually before they appear in conventional homes. More large-scale realistic testing to validate such use is needed.

### 7.7 Electrical Cable Fires

Industrial fires cause major property damage but little life loss. Financial and insurance pressures provide a beneficial influence toward industrial property conservation; governmental action is generally not needed.

However, in an exceptional case, cable fires may be sufficiently serious to be called to public attention. A relatively small fire involving a group of control cables may completely disrupt a nuclear power plant, a telephone exchange, a computer center, a steel mill, a paper mill, etc. The direct and indirect cost to society, while hard to measure precisely, is often enormous.

One approach to the electrical cable fire hazard is to use cables made of materials with high intrinsic fire resistance whenever critical applications are involved. However, it is probable that present test methods are inadequate to verify this required high fire resistance with groups of cables in complex geometries. This is especially true for cables in confined spaces such as cable tunnels, which may concentrate the heat of a fire. Thus, improvements in cable test methods are needed.

Other means for protecting cables are fire-resistant coatings and provision of automatic fire suppression systems. To determine the most economic solution in each case, more detailed information is needed than now exists on the effectiveness of each of these approaches.

A special feature of the cable problem is the traditional reluctance of the electrical designer and the professional firefighter to permit the use of the most effective agent, water, in firefighting. This reluctance exists even though application of water in certain modes produces no shock hazard to personnel and negligible water damage to equipment, according to arguments of the insurance industry.

### 7.8 Future Trends

There is every reason to anticipate that economic factors will continue to cause the replacement of wood-based products in buildings by synthetic polymeric materials. In addition, the energy crisis will produce an additional impetus for the use of polymeric materials, both in the area of insulation, discussed previously, and in the area of residential solar heating. It may be anticipated that components of solar heating systems, such as solar collectors, piping, reservoirs, etc., will be predominantly made of polymeric materials. In the initial rush to install such systems, fire safety aspects may be overlooked.

In spite of the many hazards discussed in this volume, the committee predicts no significant increase of fire fatalities due to increased use of polymeric materials in the next decade. No increase has been noted in the past decade. As noted previously, the materials hazard can be and, in many cases, is being diminished by a variety of means. These means comprise improved materials, more vigorously specified materials applications, more widespread use of automatic devices such as smoke detectors, sprinklers, door closers, etc. In the next decade, it may be hoped that major improvements in fire test methods and in systematic building design principles will make important contributions to material selection and usage.

Putting the problem in perspective, present and easily foreseeable efforts are probably sufficient to keep the building fire fatality figures from growing. However, many feel that the present United States situation, with thousands dying and tens of thousands seriously injured each year in building fires, is not acceptable at this point in our history. This is particularly so in view of much better fire records in Europe and Japan. Vigorous pursuit of the recommendations in this report should lead to a significant reduction in fire fatalities without unreasonable cost to society.

ic-  
st  
in  
le

e  
c  
e  
f  
-  
-

