

Drilling for Energy Resources (1976)

Pages
83

Size
8.5 x 10

ISBN
0309346703

Ad Hoc Committee on Technology of Drilling for Energy Resources; Energy Engineering Board; Assembly of Engineering; National Research Council

 [Find Similar Titles](#)

 [More Information](#)

Visit the National Academies Press online and register for...

- ✓ Instant access to free PDF downloads of titles from the
 - NATIONAL ACADEMY OF SCIENCES
 - NATIONAL ACADEMY OF ENGINEERING
 - INSTITUTE OF MEDICINE
 - NATIONAL RESEARCH COUNCIL
- ✓ 10% off print titles
- ✓ Custom notification of new releases in your field of interest
- ✓ Special offers and discounts

Distribution, posting, or copying of this PDF is strictly prohibited without written permission of the National Academies Press. Unless otherwise indicated, all materials in this PDF are copyrighted by the National Academy of Sciences.

To request permission to reprint or otherwise distribute portions of this publication contact our Customer Service Department at 800-624-6242.

Copyright © National Academy of Sciences. All rights reserved.

**DRILLING
FOR ENERGY RESOURCES**

**AD HOC COMMITTEE ON TECHNOLOGY
OF DRILLING FOR ENERGY RESOURCES**

**ENERGY ENGINEERING BOARD
ASSEMBLY OF ENGINEERING
NATIONAL RESEARCH COUNCIL**

**NATIONAL ACADEMY OF SCIENCES
Washington, D.C. 1976**

**NAS-NAE
JAN 4 1980
LIBRARY**

76-2080
c.1
(repl.)

NOTICE

The project that is the subject of this report was approved by the Governing Board of the National Research Council, whose members are drawn from the Councils of the National Academy of Sciences, the National Academy of Engineering, and the Institute of Medicine. The members of the committee responsible for the report were chosen for their special competences and with regard for appropriate balance.

This report has been reviewed by a group other than the authors according to procedures approved by a report review committee consisting of members of the National Academy of Sciences, National Academy of Engineering, and the Institute of Medicine.

This study was supported under Contract No. NSF-C310, Task Order 308, between the National Science Foundation and the National Academy of Sciences and was undertaken at the request of the National Science Foundation, Department of the Interior, and the Energy Research and Development Administration.

Available From:

The Energy Engineering Board
Assembly of Engineering
National Research Council
2101 Constitution Avenue
Washington, D. C. 20418

PREFACE

In response to a request from the National Science Foundation (NSF), the Department of the Interior, and the Energy Research and Development Administration (ERDA) for an assessment of the technologies used to drill for energy resources, the Assembly of Engineering of the National Research Council established an ad hoc Committee on Technology of Drilling for Energy Resources. The objectives of the committee were to: assess the state of the art in drilling technology; identify research and development priorities in the field; and, if appropriate, construct a framework for a national research and development strategy to improve the technology for recovering oil, natural gas, coal, shale oil, water, nuclear fuels, and geothermal energy.

At the outset, the committee sought an understanding of the role of drilling in the recovery of energy resources as well as the conditions under which drilling takes place. Thus, in examining specific drilling technologies, the committee attempted to determine the state of the art and to identify the technical constraints. On the basis of the information gained during its assessment, the committee narrowed its attention to the specific problems. The committee's appraisal of these problems provides the basis for the recommendations in this report.

While the committee was considering the technical factors for improving drilling techniques, it found that major nontechnical constraints often are decisive to drilling for energy resources. Accordingly, the committee found it necessary to consider the nontechnical constraints which cross a whole spectrum of energy issues. These include capital availability, environmental protection requirements, antitrust and patent policies, and availability of government land for exploration and development. Because these are recognized today as constraints affecting drilling technology, the committee has concluded that a study of these concerns in greater depth is needed to explore their full ramifications for increasing the domestic supply of energy resources.

The committee found that there is a broad range of opinions on these issues and a meager amount of substantiated fact. Both the perceived problems and the possible solutions are so diverse that the committee recognized that, like society at large, it would not be able to reach a consensus.

In the matter of land availability, for example, some committee members argued for strict land leasing regulations and environmental controls, while others suggested that such actions would inhibit the development and production of energy resources, and that the delays that would inevitably result would seriously hamper capital investment and, therefore, energy recovery.

In the matter of price regulations, opinions ranged from the belief that regulation of market prices limits profits and, therefore, capital investment, to a disbelief of any industry statistics and statements regarding profits and investments.

Antitrust and patent policies received a greater degree of agreement. The possibility of antitrust action, which was raised by the committee members from industry, is recognized at the administrative level by most major government agencies. As far as patent policies are concerned, the committee observed that past government practices have been restrictive, particularly in requiring the release of background patents and proprietary information. Statements obtained by the committee from ERDA officials reflect a sensitivity to the need for more flexible regulations in the future.

After addressing these problems in a general way, the committee agreed not to assess them in its report. Committee members recognized that they were not selected for their expertise and experience in nontechnical matters relating to the issue. Moreover, a study of six-months duration would not have allowed sufficient time to analyze nontechnical questions and place them in the proper perspective. Finally, conflicting viewpoints--as to the proper amounts and types of government regulation of the energy industry--could not be resolved by this committee.

The committee would like to note that nontechnical constraints are considered to have a decisive effect in limiting the rate of exploration and exploitation of the nation's energy resources. Even if the drilling rate is made more effective and efficient through technology, substantial increases in this rate will not be directly reflected in a comparable improvement in the whole energy resource recovery system because of nontechnical restraints. Nevertheless, the committee feels it is important to go ahead with the recommended technical improvements.

In order to perform the study effectively, the committee gathered information on the state of the art in drilling technology by conducting a Drilling Technology Workshop at Park City, Utah, between June 25-27, 1975. The participants included experts from all segments of the drilling industry as well as from the government, universities, and private research laboratories. The background papers and discussions that were part of the workshop have been published earlier (NRC, 1975). The workshop material and subsequent discussions with numerous government and industry experts provided the base material for the overview of the drilling industry and the descriptions of current drilling technology.

Although the report covers gaseous, fluid, and solid energy resources, the emphasis is on the equipment and techniques used to drill for petroleum, natural gas, and geothermal resources. The committee recognized, both during the workshop and in subsequent meetings, that with few exceptions the major technical complexities and problems of drilling for energy resources lie in the equipment and techniques used to drill very deep holes through a broad range of strata. Also, oil and gas drilling technology provides a convenient standard against which other drilling technologies can be gauged. The only substantive purpose of describing the technology is to set forth the state of the art for those unfamiliar with the industry.

SUMMARY

Drilling is integral to the exploration, development, and production of most energy resources. Oil and natural gas, which are dependent on drilling technology, together account for about 77 percent of the energy consumed in the United States. Thus, the limitations of current drilling technology also restrict the rate at which new energy supplies can be found, extracted, and brought to the marketplace. The purpose of the study reported here was to examine current drilling technology, suggest areas where additional research and development (R&D) might significantly increase drilling rates and capabilities, and suggest a strategy for improving drilling technology.

This report provides an overview of the U.S. drilling industry. It describes the drilling equipment and techniques now used for finding and recovering oil, natural gas, coal, shale oil, nuclear fuels, and geothermal energy. Although by no means exhaustive, these descriptions provide the background necessary to adequately understand the problems inherent in attempts to increase instantaneous and overall drilling rates.

State of the Art

More than \$4 billion will be spent this year drilling for energy resources in the United States--double the expenditure of only three years ago. This represents only about 2 percent of the \$200 billion spent annually by the U.S. energy industry. Clearly, drilling is a vital link in the chain of exploration, discovery, and production. The development rate for most energy resources depends directly on the capabilities and capacities of the drilling industry.

In drilling for oil and gas, more than 95 percent of the work is done by some 10,000 companies, usually operating under contracts with the big energy producers. By contrast, mining companies generally do more of their own drilling, usually on a continuing basis as they discover and recover such resources as coal or uranium.

While the government has helped support, at a relatively low level, the development of mining technologies, the technology of oil and gas recovery has been left almost entirely to the energy industry. During the era of cheap and abundant energy, this system generally worked well. However, several significant--perhaps fundamental--events have had an effect on drilling technology in recent years: inflation has escalated the costs of manpower and equipment; national and state environmental protection laws have accelerated costs and slowed development rates for some energy resources; dependence upon higher-priced foreign energy sources has increased sharply, leading to a

national policy to decrease the vulnerability to foreign political and economic decisions by raising domestic energy production; and federal price controls and allocation programs have affected some forms of energy.

Recovering oil, natural gas, and geothermal energy requires different drilling equipment and techniques from recovering solid or semi-solid resources such as coal, uranium, shale oil, and tar sands. Moreover, climatic and environmental conditions such as permafrost in the Arctic and ocean currents, waves, and corrosion effects bear upon the equipment, technology, rate, and cost of drilling for energy resources.

Limitations and Opportunities

Chapter 3 contains discussions of (1) the current technical limitations, (2) the areas offering the greatest potential for technical innovation, and (3) the committee's recommendations for government assistance to supplement industry's R&D efforts in the areas. In the recovery of oil, gas, and geothermal resources, for instance, the limitations range from a shortage of available drilling rigs and personnel to the need for improved drill bits, downhole testing and telemetry systems and better basic understanding of rock mechanics. These problems are compounded in the Arctic and offshore environments, where protection is required for personnel and machinery, and more stringent pollution controls must be applied.

Geothermal drilling, although performed almost exclusively on land, presents some unusual problems. The strata generally consist of hard, abrasive, fractured rock that causes a substantial shortening of the usual life of drill bits, results in unintentionally deviated or angled holes that wear the drill pipe rapidly, and contributes to frequent losses of drilling fluid circulation to underpressurized formation fluid zones. Additionally, the heat and brine in geothermal zones lead to metal fatigue, corrosion, and erosion problems as well as problems with seals, lubricants, and other materials.

For minable resources, the primary drilling problems concern methods of controlling the strata and formation fluids. Although small hole drilling equipment and techniques (such as those used for blast holes) are well developed, drilling of rock bolt holes for tunnel ceiling support is still hazardous to equipment operators. Equally hazardous is the potential flooding of the mine by formation fluids during raise drilling (holes drilled upward) or up-reaming (upward enlargement of pilot holes). Current R&D efforts aimed at mitigating these problems include providing remotely controlled, pumpable rock bolt placement systems and methods of shutting off formation water prior to raise drilling or up-reaming.

Lightweight and mobile mechanized tunneling equipment for cutting noles of varying shapes and sizes in medium hard and hard rock is

not available at present, although such equipment has been sought for many years. A prototype tunneling machine that combines the use of high-pressure water jets with conventional mechanical cutters is now being developed, and it may significantly increase penetration rates. However, significant emphasis should be brought to bear on developing better tunneling machines.

Recommendations

Government support of drilling R&D is probably necessary if substantial increases in instantaneous and overall drilling rates are to be effected in the near future. Generally speaking, increased drilling costs and the need to put most of the available capital into exploration and development of such high-risk, high-pay off areas as the continental shelf and the Arctic, discourage the private funding of drilling R&D. Also, the need to rapidly commercialize all innovations throughout the entire industry either prevent the normal leasing arrangements that allow companies to recover a portion of their R&D costs or price the innovations beyond the financial capabilities of the small companies that constitute the bulk of the drilling industry. In either case, the purpose--to increase energy resource recovery by increasing drilling rates--is not served.

If drilling is to advance to meet the nation's energy needs in the next decade, government-supported R&D will need to complement the large, ongoing efforts of the industry. Decisions on funding levels for specific aspects of the technology and for basic studies in science and engineering need to be made by joint government-industry teams of experts on the basis of the perceived problems and priorities. As a guideline for such an activity, the committee recommends that federal funding in the range of \$100 million to \$200 million should be devoted in the next five years to an R&D strategy in the following ways:

- o To supplement the industry's efforts in developing new equipment such as downhole motors and telemetry systems, \$10 million to \$20 million;
- o To support studies in universities and research organizations of basic drilling mechanics and new materials, \$6 million to \$12 million;
- o To accelerate the development of promising advanced or novel drilling systems on land and in deep water, particularly in the Arctic, and to support research on permafrost and cold weather conditions, \$17 million to \$29 million;

- o To foster technical training programs in school and industry in order to increase the number of skilled workers, as well as additional scientists and engineers in the field, \$4 million to \$8 million;
- o To develop and improve high-temperature equipment and fluids needed for recovering geothermal steam, \$5 million to \$15 million;
- o To help offset the risks that industry is bound to encounter in adopting new drilling technology, \$20 million to \$30 million;
- o To improve upon drilling methods, particularly for large holes and raise bores, rotary-percussion and horizontal techniques, and to develop lightweight and mobile mechanized tunneling machines for recovering coal, uranium, and oil shale, \$15 million to \$30 million;
- o To speed up work on cutting drills and materials, and develop and commercialize new mining methods such as water-jet cutting of coal, \$17 million to \$34 million; and
- o To increase the current level of support by the Bureau of Mines and the National Science Foundation for innovative drilling equipment and techniques in mining, \$10 million to \$20 million.

Joint government-industry planning in this program is considered essential by the committee if federal funding is not to become a reason for the industry to cut back or eliminate substantial portions of its R&D efforts.

Research and Development Strategy Framework

In terms of implementation, the committee recommends that ERDA should take the initiative in formulating a communication and coordination plan for government and industry that will assure that the projects undertaken have good prospects of achieving results calculated to be attractive to the drilling industry. This plan, moreover, will need to extend to the whole energy research and development effort, not just to a single technology such as drilling. Such cooperative efforts should include jointly funded R&D projects as well as information transfer, identification of technologies heretofore overlooked, and areas in which additional public or private participation might facilitate the research and development or deployment of technology that has been or is being developed.

Such a communication and coordination effort is necessary to overcome the proprietary tendencies ingrained in competing companies and the mutual suspicions of government and industry. Of the major agencies having actual or implied authority in the energy field, ERDA provides the best means of developing full cooperation among the diverse participants because of its primary mission and central position in the field.

One of the criteria and, indeed, one of the tests of successful R&D efforts is commercialization. Even for industry, this is very difficult to practice. Commercialization will be even more difficult to accomplish in government-industry relations. Therefore, for successful commercialization, the committee recommends that, at the outset, a market analysis reflecting the views of the potential buyers should be performed particularly by individuals not associated with the proposed research and development; that each program be designed from initiation to commercialization to provide a product that possesses the characteristics derived from the market analysis; that program performers be selected who are recognized as among the best in that field of activity; and that agreements and funding for each program be arranged to provide the program with a good chance to succeed.

Because government laboratories contain a wealth of testing and evaluation capabilities that should be used in pursuit of better drilling technologies, the committee recommends that the government establish a program wherein private companies could use the appropriate government test facilities on an incremental cost basis, when such projects are in the national interest. This would avoid expensive duplication of such facilities by industry, foster additional cooperative efforts between government and industry technical personnel, and promote full use of the test facilities. This program could be administered by a board made up of representatives of government, industry, and public interest organizations.

Finally, the committee recommends that the National Academy of Sciences-National Academy of Engineering-National Research Council plan a program of symposia in which the work, plans, and programs of government and industry would be delineated in order to help advance effective communication and joint goals for all participants in the energy field. Such an activity is needed to adequately explain the proposed joint ventures to the highly fragmented energy industry and to reach those segments of government and industry that, though not directly associated with specific technologies, may help alleviate nontechnical constraints. If nothing more, this effort should make all participants and interested observers fully aware of the directions and potentialities of the various R&D efforts currently under way, which is the starting point for cooperative efforts.

AD HOC COMMITTEE ON TECHNOLOGY
OF DRILLING FOR ENERGY RESOURCES

Members:

*John S. Foster, Jr., Committee Chairman
Vice President, TRW Inc.
General Manager, Energy Systems Group
Redondo Beach, California

*Robert F. Bauer
Chairman of the Board
Global Marine Inc.
Los Angeles, California

*W. Kenneth Davis
Vice President
Bechtel Power Corp.
San Francisco, California

Kenneth E. Gray
Department of Petroleum Engineering
University of Texas
Austin, Texas

*Claude R. Hocott
Division of Chemical Engineering
University of Texas
Austin, Texas

Lionel Kestenbaum
Bergson, Borkland, Margolis & Adler
Washington, D.C.

William C. Maurer
Maurer Engineering Inc.
Houston, Texas

Stanley C. Moore
Chairman of the Board
Smith International, Inc.
Houston, Texas

N. Allen Riley
President
Chevron Oil Field Research Co.
La Habra, California

*Members of the National Academy of Engineering

Irvin L. White
Department of Political Science
Science and Public Policy Program
University of Oklahoma
Norman, Oklahoma

Robert L. Whiting
Department of Petroleum Engineering
Texas A & M University
College Station, Texas

Staff:

John O. Berga
Executive Director
Energy Engineering Board
Assembly of Engineering
National Research Council
Washington, D.C.

Jack W. Boller
Executive Director
Marine Board
Assembly of Engineering
National Research Council
Washington, D.C.

John B. Cheatham
Professor of Mechanical Engineering
Rice University
Houston, Texas

Mark Elder
Associate Director
Office of Research Administration
University of Oklahoma
Norman, Oklahoma

Sidney J. Green
President
Terra Tek, Inc.
Salt Lake City, Utah

Virginia Lyman
ad hoc Committee on Technology of Drilling
for Energy Resources
Assembly of Engineering
National Research Council
Washington, D.C.

CONTENTS

TABLES AND FIGURES.....	xii
CHAPTER 1. INTRODUCTION.....	1
CHAPTER 2. CURRENT DRILLING TECHNOLOGY FOR ENERGY RECOVERY.....	4
Oil, Gas, and Geothermal Drilling Technology.....	4
Coal, Uranium, Oil Shale, and Tar Sands Drilling Technology.....	27
CHAPTER 3. TECHNICAL LIMITATIONS, OPPORTUNITIES, AND RECOMMENDATIONS.....	37
Oil, Gas, and Geothermal Limitations and Opportunities.....	37
Recommendations for Oil, Gas, and Geothermal Drilling.....	46
Coal, Uranium, and Oil Shale Limitations and Opportunities.....	50
Recommendations for Coal, Uranium, and Oil Shale Drilling.....	52
CHAPTER 4. IMPLEMENTATION.....	55
GLOSSARY OF TERMS.....	60
REFERENCES.....	63
A SELECTED BIBLIOGRAPHY.....	66

CHAPTER 1

INTRODUCTION

More than \$4 billion will be spent this year drilling for energy resources in the United States--double the expenditure of only three years ago. This represents only about 2 percent of the \$200 billion spent annually by the U.S. energy industry. Clearly, drilling is a vital link in the exploration, discovery, and production chain. Development rates for most energy resources depend directly on the capabilities and capacities of the U.S. drilling industry.

Most energy resource drilling is done by private drilling companies under contracts with the energy-producing companies. More than 95 percent of oil and gas wells in the U.S. are drilled by some 10,000 companies, ranging in size from very small firms with only local or regional operations to large firms with worldwide operations. In contrast, companies that produce resources by mining generally do more of their own drilling. In the production of minable energy resources, drilling is a continuing activity. In the production of oil, gas, and geothermal energy, drilling is a major activity only at the outset of production.

The differences in drilling for liquid, gaseous, and solid resources point up the range of purposes for which drilling technologies are used in energy production. Drilling is the major tool used in the exploration, definition, and development of oil, gas, and geothermal resources. The recovery of these resources requires deep holes of relatively small diameters, and thus similar drilling equipment and techniques can be used. The exploratory and definition stages for minable resources may require holes similar to oil or gas wells (although normally much shallower). However, at the development stage very large-diameter access and ventilation shafts may be required. Drilling requirements at the production stage may range from very small diameter, very shallow blast holes to large tunnels. These quite different requirements necessitate a wide range of drilling equipment and techniques.

Since the mid-1920's the development and commercialization of oil and gas drilling technologies have been left almost entirely to the energy industry. However, the government has been an active participant in the

development of mining technologies, although at a relatively low level of expenditures. So each of these industries has determined, largely on its own, what is economically and technologically feasible.

During the period of cheap and abundant energy, this system generally worked well. However, several significant and perhaps fundamental events have altered the situation in recent years. Inflation has escalated the costs of manpower and equipment; national and state environmental protection laws have increased costs and slowed development rates of some energy resources; dependence upon higher-priced foreign energy sources has increased sharply; federal price controls and allocation programs have been imposed; and a national policy has been adopted to decrease dependence on foreign sources by increasing domestic energy production. In combination, these factors have resulted in a much more active government role in energy resource development, including the development and commercialization of new and improved drilling technologies.

The Committee has observed in the course of its study that the lack of adequate mechanisms for cooperation and coordination between industry and government is a major barrier to the development and utilization of new or improved drilling technologies. Government experience in large-scale research and development has, for the most part, been in areas such as national security, outer space, and nuclear energy, where the government was the customer. Government's role in energy, except for nuclear and perhaps solar, will be to expedite development and widespread utilization of technologies which can contribute to the achievement of national objectives. Consequently, government and industry need to be involved from the inception of development programs if technologies are going to be transferred effectively from a government research and development program to the energy industry.

Other nontechnical considerations also affect the development and commercialization of new and improved drilling technologies for energy resource development, although most are not peculiar to drilling or to energy. These include the availability of capital and land as well as resource management, antitrust and patent laws, and taxing policies. These and other nontechnical considerations require attention. However, the committee's charge was to focus its attention on drilling technology.

Although the technical limitations identified relate primarily to the capabilities of drilling rigs, a shortage of rotary drilling rigs and of trained personnel exists. Most of the technological problems concern instantaneous drilling rates for specific formations and methods for increasing the overall drilling rate for each rig, such as by reducing

the percentage of nonproductive time spent in changing bits, coring, and surveying. For example, instantaneous drilling rates can be increased by improving drill bits, drilling fluids, and knowledge of rock mechanics. Overall drilling rates can be increased by improving bit life, developing downhole instrumentation, and improving component reliability.

Technical progress can be accelerated by the combined research, development, and commercialization efforts of government, industry, universities, and private research laboratories. A number of existing government-industry-university interfaces can be used to facilitate these efforts, but others must be created. For example, government funding of university research projects is well established in such areas as rock mechanics. Only the amounts of funds and priority areas need to be changed. Also, government funding of cooperative university-industry, government-industry, and government-industry-university projects have numerous precedents. The new interfaces will result primarily from bringing together groups that have not previously worked with each other. These interfaces should be created and the groups formed on the basis of specific tasks.

Commercialization of the new equipment, supplies, and technologies resulting from these R&D efforts will be necessary to increase the total annual footage drilled for energy resource recovery. Thus, in some cases government action will be needed to foster the capitalization of new equipment and techniques.

CHAPTER 2

CURRENT DRILLING TECHNOLOGY FOR ENERGY RECOVERY

Although drilling activities vary widely, the equipment and techniques used can generally be divided into those applicable for recovering fluid and gaseous resources (petroleum, natural gas, and geothermal water/steam), and those for recovering solid and semi-solid (minable) resources (coal, uranium, shale oil, and tar sands). The first category is dominated by rotary drilling equipment and techniques developed for drilling relatively small-diameter holes to great depths. The second category uses percussive, rotary, and rotary-percussive equipment and techniques primarily to drill either small, shallow holes (as for planting explosive charges) or large, deep shafts (as for mine entrance and exit, and ventilation).

Oil, Gas, and Geothermal Drilling Technology

In 1973, there were 26,244 oil and gas wells drilled in the United States, totaling 136.7 million linear ft. As shown in Table 1, the average depth of these wells was 5,207 ft. The average cost was \$117,152 per well or \$22.50 per ft drilled. Of those wells, 60 were drilled to depths of more than 20,000 ft at an average cost of more than \$2 million per well. The cost of drilling increases with depth and in adverse environments, such as in the Arctic and offshore. (See Table 2)

Improved drilling technology more than doubled the average annual footage drilled per rig from 1945 to 1973, as shown in Table 3. But the total annual footage drilled dropped by about 40 percent from 1955 to 1973 because of a 55 percent decline in the number of rigs operating. (Brantly, 1971; Letter, S.C. Moore to John Foster, Oct. 3, 1975). Since the oil embargo in the winter of 1973-74, this decline has been reversed. During 1975, an estimated 35,000 new wells were drilled by an average of 1,600 rigs (Garrison, 1975; Hughes Tool Company, 1975). Almost all available drilling rigs are currently in use.

Table 1. U.S. Total Estimated Costs of Oil and Gas Drilling for 1973.

<u>Type</u>	<u>Wells No.</u>	<u>Total Footage (x10⁶)</u>	<u>Total Costs, Millions of Dollars</u>	<u>Average Depth Feet</u>	<u>Average Cost per Well,* Dollars</u>	<u>Average Cost per Ft.* Dollars</u>
Oil	9,705	44.7	1,007	4,602	103,758	22.54
Gas	6,427	36.3	998	5,654	155,272	27.46
5 Dry Holes	10,112	55.7	1,070	5,504	105,778	19.22
Total	26,244	136.7	3,075	5,207	117,152	22.50

Joint Association Survey of the U.S. Oil and Gas
Producing Industry for 1973 (1975).

*Includes all costs for drilling and equipping wells through the "Christmas Tree."

Table 2. Estimated Costs of Drilling Oil and Gas Wells in the United States During 1973.

<u>Depth Interval (feet)</u>		<u>No. Wells</u>	<u>Total Cost x10⁶ (\$)</u>	<u>Average Cost per Well x10³ (\$)</u>
5,000- 7,499	U.S. Total	5421	536	99
	U.S. Total Offshore	179	75	420
	Alaska	4	3.5	887
7,500- 9,999	U.S. Total	3334	613	184
	U.S. Total Offshore	271	153	563
	Alaska	8	12	1467
10,000-12,499	U.S. Total	1544	525	340
	U.S. Total Offshore	199	150	751
	Alaska	14	15	1096
12,500-14,999	U.S. Total	622	391	628
	U.S. Total Offshore	129	129	1000
	Alaska	1	6	6145*
				(Dry Hole-No Oil or Gas)
15,000-17,499	U.S. Total	295	254	862
	U.S. Total Offshore	33	46	1408
	Alaska	3	5.5	1843
17,500-19,999	U.S. Total	84	107	1278
	U.S. Total Offshore	2	3	1466
	Alaska	0	0	0
20,000 and over	U.S. Total	60	120	2008
	U.S. Total Offshore	0	0	0
	Alaska	0	0	0

Joint Association Survey of the U.S. Oil and Gas Producing Industry for 1973 (1975).

Table 3. Oil and Gas Drilling Statistics.

Year	Total New Wells Completed	Total Footage Drilled (x 10 ⁶ ft)	Average Depth (feet)	Record Well Depth (feet)	Average No. of Rotary Rigs Running in U.S.	Average Annual Footage per Rig
1945	26,649	92	3,489	16,655	1,744	52,752
1955	56,850	230	4,044	21,482	2,687	85,597
1965	40,374	178	4,415	25,340	1,388	128,242
1973	26,244	137	5,207	31,411	1,200	114,167

Joint Association Survey of the U.S. Oil and Gas Producing Industry for 1973 (1975).

Rotary Drilling

The major rotary drilling components are surface equipment, the drill string,* testing and evaluation tools, and well-completion equipment. The surface components produce and transmit power, hoist and rotate the drill string, and circulate the drilling fluid. Figure 1 shows the basic components of a rotary drilling rig.

Power is usually produced by diesel- or gasoline-fueled engines that drive the rig equipment mechanically by means of chain and belt drives or electrically by use of generators and electric motors, as show in Figure 2. Heavy-duty rigs for 20,000 ft or deeper holes usually have 3 or 4 engines with a typical combined capacity of 3,000 hp. However, only 20 to 40 mechanical hp is transmitted to the rock by the drill bit in conventional rotary drilling (Maurer, 1968).

The majority of equipment on a rig is monitored and controlled from the driller's station. This station normally contains levers and valves that allow adjustment of engine speed, fluid pressure, weight-on-bit (assumed to be the difference between the total weight of the drill string and the suspended weight) and the blowout preventer (which closes the annular space between the casing and drill pipe or the open hole when the pipe is not in the hole). The station also contains instrumentation that displays the current state of rig components.

Rig instrumentation is extensive. Tachometers indicate engine speed, and manifold pressure gauges and/or cylinder temperature gauges indicate engine power. On an electric rig, rotary torque is indicated by an ammeter, which shows the current being drawn by the rotary table motor. The weight indicator is a hydraulic-type instrument that shows the weight of the drill string suspended from the derrick.

A pressure gauge measures the circulating fluid pressure. Pit level indicating instruments and fluid-flow sensors indicate fluid gains or losses. These instruments warn the driller of conditions that may result in a loss of pressure control in the well, which could result in a blowout.

*The drill bit and pipe. (For an explanation of technical terms, see Glossary.)

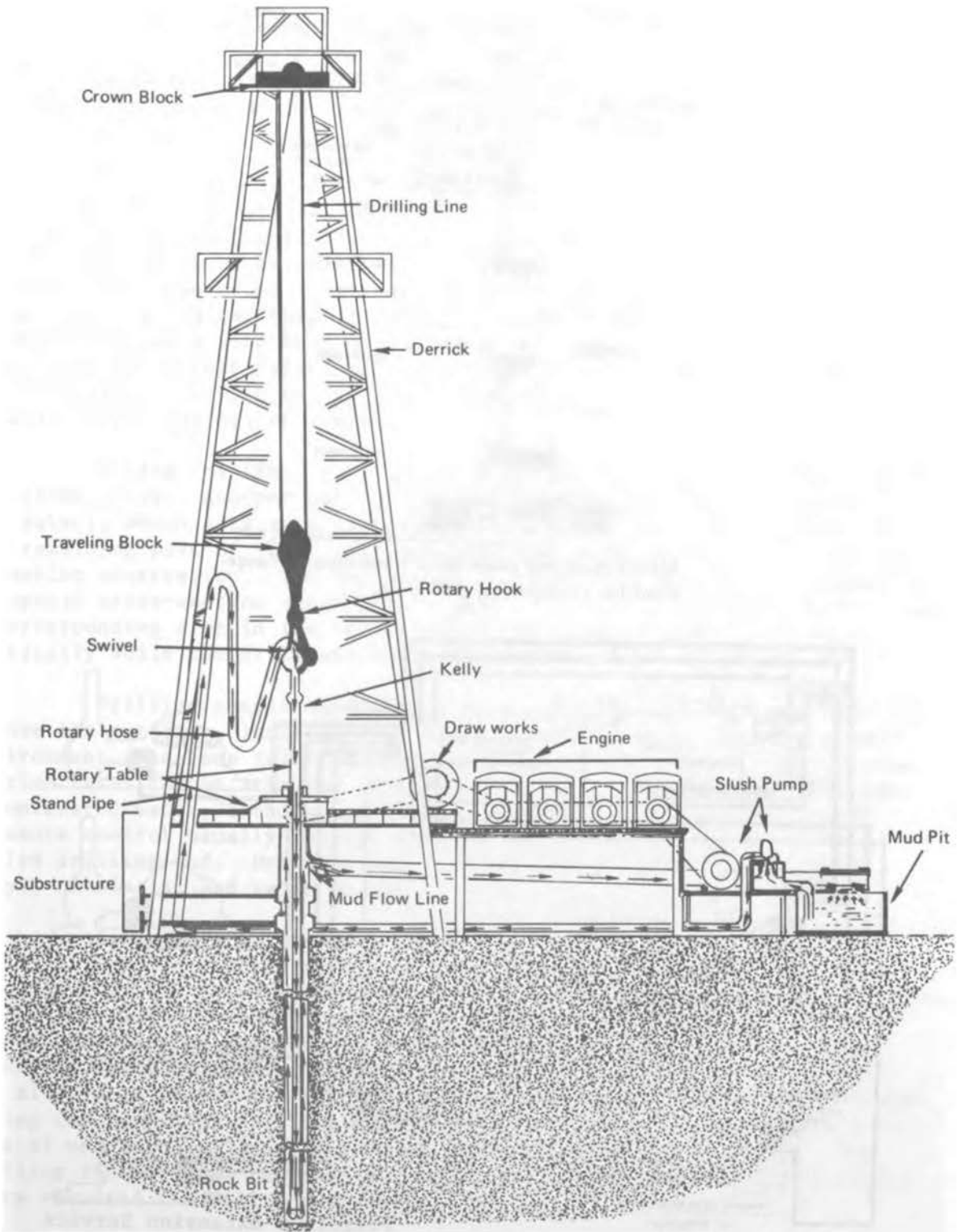
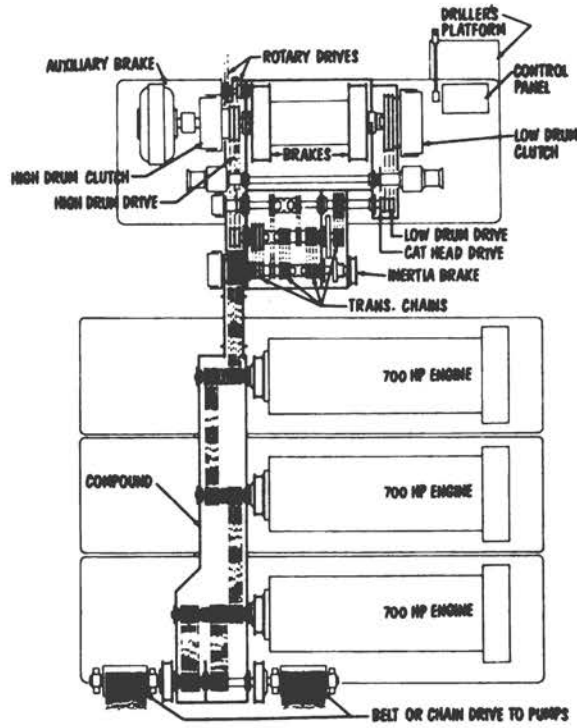
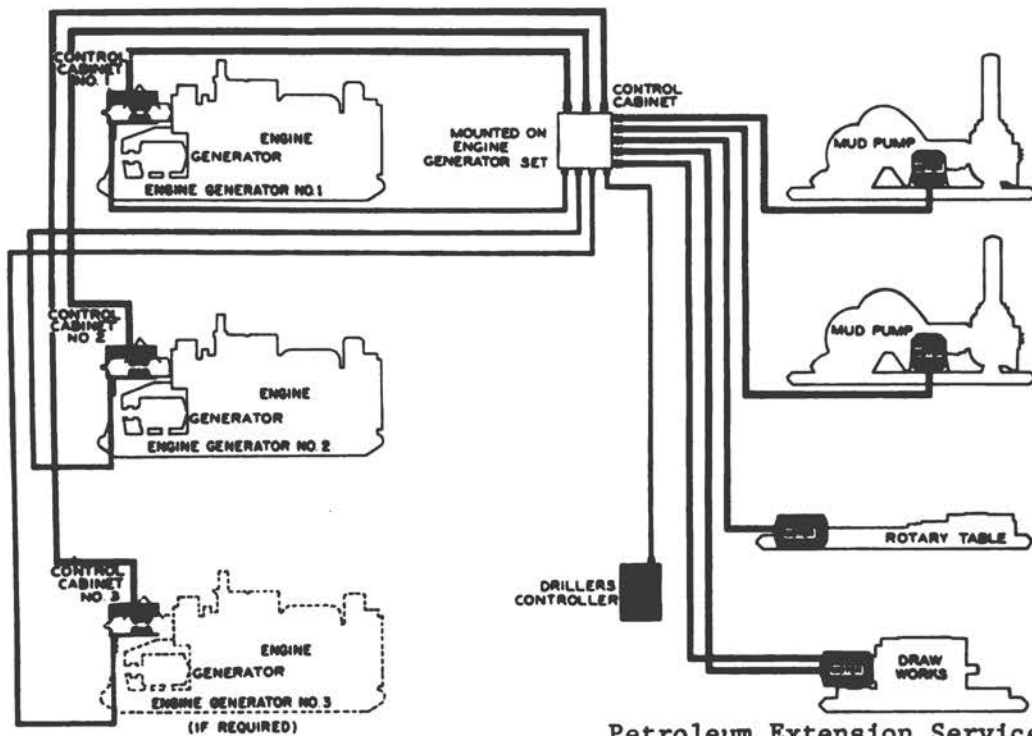

Figure 1. Basic Components of a Rotary Drilling Rig



Multi-engine and chain drive transmission arrangement for a mechanical drilling rig.



Petroleum Extension Service
University of Texas at Austin

Figure 2. Diesel-electric System for Power and Transmission

Using the controls and instrumentation described above, the driller (instructed by the tool pusher or drilling engineer) attempts to select combinations of weight-on-bit, rotary speed, and fluid circulation that will give the most favorable penetration rate for the formation being drilled.

The derrick is a load-bearing structure that must be capable of supporting the drill string and heavy casing strings. Standard derricks were originally permanent structures made of wood. These derricks have now largely been replaced by steel masts, which are portable derricks that can be raised and lowered as a unit without disassembly. For deep wells (20,000 ft or more), a typical mast is capable of supporting a vertical load of 1,500,000 lb and a wind load of 130 mph. The draw works (Figure 1) consists of a large winch that raises and lowers the drill string by means of the drilling line. A brake on the winch drum controls the lowering of the load of drill pipe, casing, or tubing.

During drilling, part of the drill string weight is supported by the crown block. Another part of the drill string weight is supported by the swivel, which acts as a rotating pressure seal for the drilling fluid. The remaining part of the drill string weight rests on the bit to facilitate formation penetration. The top section of the drill string is a square or hexagonal cross-section steel pipe called a "kelly." The kelly fits through a corresponding slot in the rotary table, which allows the kelly to move vertically while the drill string is rotated and the bit deepens the hole.

Drilling operations require a circulation system in the hole to remove the cuttings, lubricate the drill string and bit, maintain a safe environment, and keep friction heat within allowable levels. Faster penetration rates can be achieved in most formations by circulating air, gas, or untreated water, although problems of borehole stability and fluid-pressure control usually require a chemically treated thixotropic fluid called drilling mud. Drilling mud is a mixture of weighting materials, clays, chemicals, and water or oil.

Figure 3 illustrates a typical drilling fluid system. The drilling fluid is circulated by mud pumps (Figures 2 and 3) with typical capacities of 600 gal/min and up to 4,000 lb per square inch (psi) pressure. Mud is circulated downward through the drill string and bit and returned through the annulus between the borehole and drill string to the shale shaker (a set of vibrating screens that shunt cuttings to a refuse pile but allow most of the mud to drain into a settling pit for eventual reuse). During the course of drilling a typical 15,000-ft well, approximately 110 tons of mud are used and 950 tons of drill cuttings are produced. The drilling fluid system represents a major part of the equipment and supply costs required to drill a deep well.

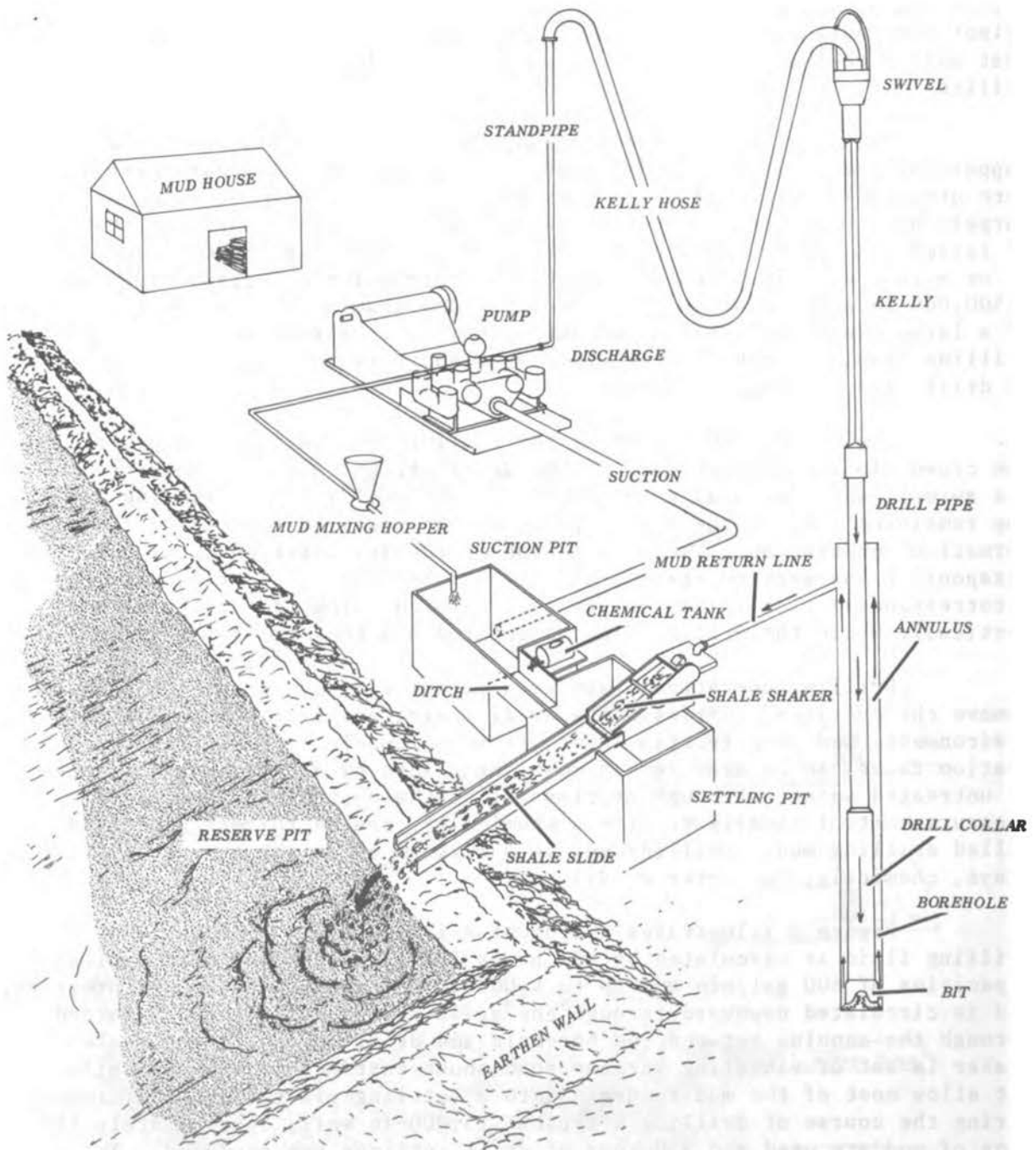

Petroleum Extension Service
University of Texas at Austin

Figure 3. Rotary Rig Fluid Circulation and Mud Treating System

Drill String

The drill string is the entire rotatable drilling column: the kelly, drill pipe, and drill collars (Figure 3). The steel drill pipe sections, which are male and female threaded for easy assembly or disassembly, are made in various sizes to meet various needs but are commonly 5 in. in diameter and 30 ft in length. Conversely, the drill collars, which transmit thrust to the bit, may be as large as 12 in. in diameter to add weight to the bit.

As the hole is deepened, additional sections of pipe are added to the string. This procedure, called "making a connection," involves stopping the rotary table and mud pumps and supporting the drill string from the rotary table while a section of pipe is added between the kelly and the rest of the drill string.

When a bit becomes dull, or a different bit type is required, a "round trip" is made, which consists of removing all the drill string from the hole, changing the bit, and returning the drill string to the hole. The pipe is usually removed in three-section lengths of approximately 90 ft each called "stands," because these sections stand (are stored) in the corners of the derrick until reinserted in the hole. In a deep well, a round trip may require 10 to 15 hours.

The actual penetration of the formation being drilled is done by the drill bit. Bits vary in size, cutting surface materials, and cutting action, but all have openings for the fluid circulation system. The particular bit type used in a given drilling operation depends on the properties of the formations to be drilled, drilling fluid properties, depth, potential drilling rate, and cost and expected life of the bit. For example, drag-type bits, which drill by a scraping action, can be used in soft (weak and nonabrasive) formations. These bits have high drilling rates, but they wear so rapidly that they are infrequently used.

Most rotary drilling is performed with three-cone roller bits of the type illustrated in Figure 4. These bits drill by breaking the rock and crushing the pieces between the bit teeth. Soft-formation roller bits have long teeth, and the cones are skewed to produce some gouging instead of a pure rolling action. Roller bits used to drill strong and abrasive formations have shorter teeth, larger bearings, and cone angles that give a pure rolling action. The teeth on these bits are normally made of, or tipped with, tungsten carbide. Both roller and journal (sleeve) bearings are used in roller bits, and the bearings are often sealed within a

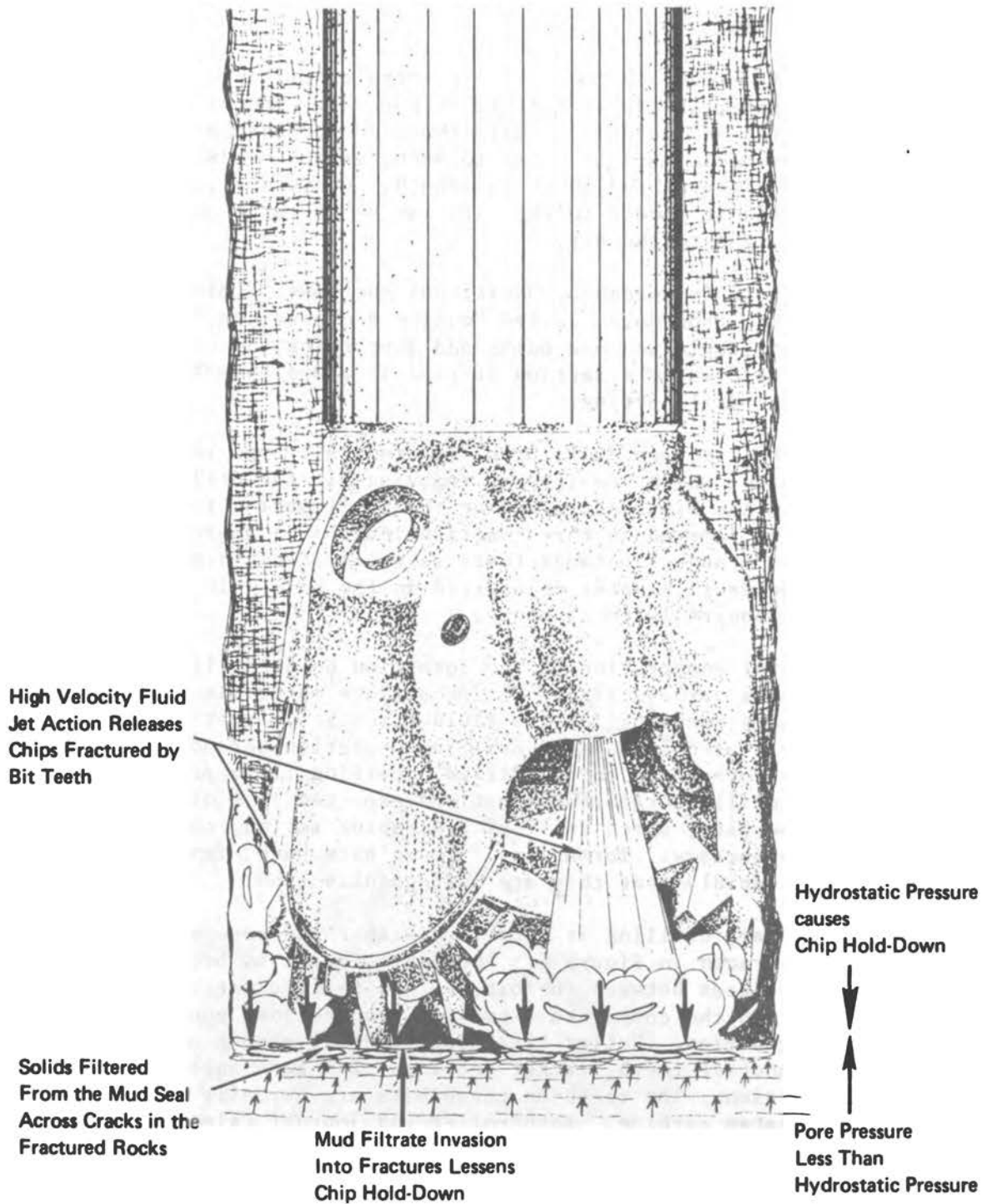

Petroleum Extension Service
University of Texas at Austin

Figure 4. Roller-cone Rock Bit

lubrication reservoir. Some roller bits have jet nozzles (as shown in Figure 4) that direct a high velocity fluid stream against the hole bottom to aid in removal of the drill cuttings.

Diamond bits may be used under special circumstances. These bits contain small diamonds set in a matrix which cut the rock with a grinding action. In very hard and abrasive formations, a diamond bit may drill more footage than a roller bit but at a lower drilling rate. In very deep wells, the higher cost of the diamond bit may be offset by the reduced number of round trips required for changing bits.

Instantaneous drilling rates decrease as the strength of the formation increases (Figure 5; Maurer, 1968). Further, as depth increases, drilling rates for almost all formations decrease because the greater pressures make the rocks more plastic and thus harder to fracture.

Although no hole is exactly vertical, those with less than a 5-degree inclination are usually considered to be vertical (Jenner, 1973; Garrison, 1975). The control of vertical hole deviation (Figure 6) is part of the art of drilling.

Corrections are made primarily by a trial-and-error procedure which is based partly on experiences in wells previously drilled in the same field. The hole angle is increased, maintained, or decreased by various combinations of bit weight, rotary speed, and stabilizer positions on the drill collars to increase or decrease their pendulum effect. To prevent sudden changes of hole direction (called "dog legs"), particularly when drilling into inclined layered formations, packed-hole assemblies are frequently used. These collars provide very small clearances in the borehole and thereby resist hole direction changes. In extreme cases, undesirable angle buildup may be prevented by using low weight-on-bit. However, this low weight also reduces penetration rates significantly.

"Directional drilling" refers to holes that are intentionally angled, although an unintentionally deviated hole can be considered as directionally drilled (Jenner, 1973; Garrison, 1975). Until recently, jet deflection techniques and/or a tapered wedge called a "whipstock" were used to push the bit in the desired direction depending on the hardness of the formation. As shown in Figure 7, the whipstock uses a smaller bit to drill a directional pilot hole. After the pilot hole is enlarged to accommodate the full-gauge drilling bit, the whipstock is pulled out and reset as needed to achieve sufficient angle buildup. This procedure requires numerous round trips and can produce unwanted dog legs.

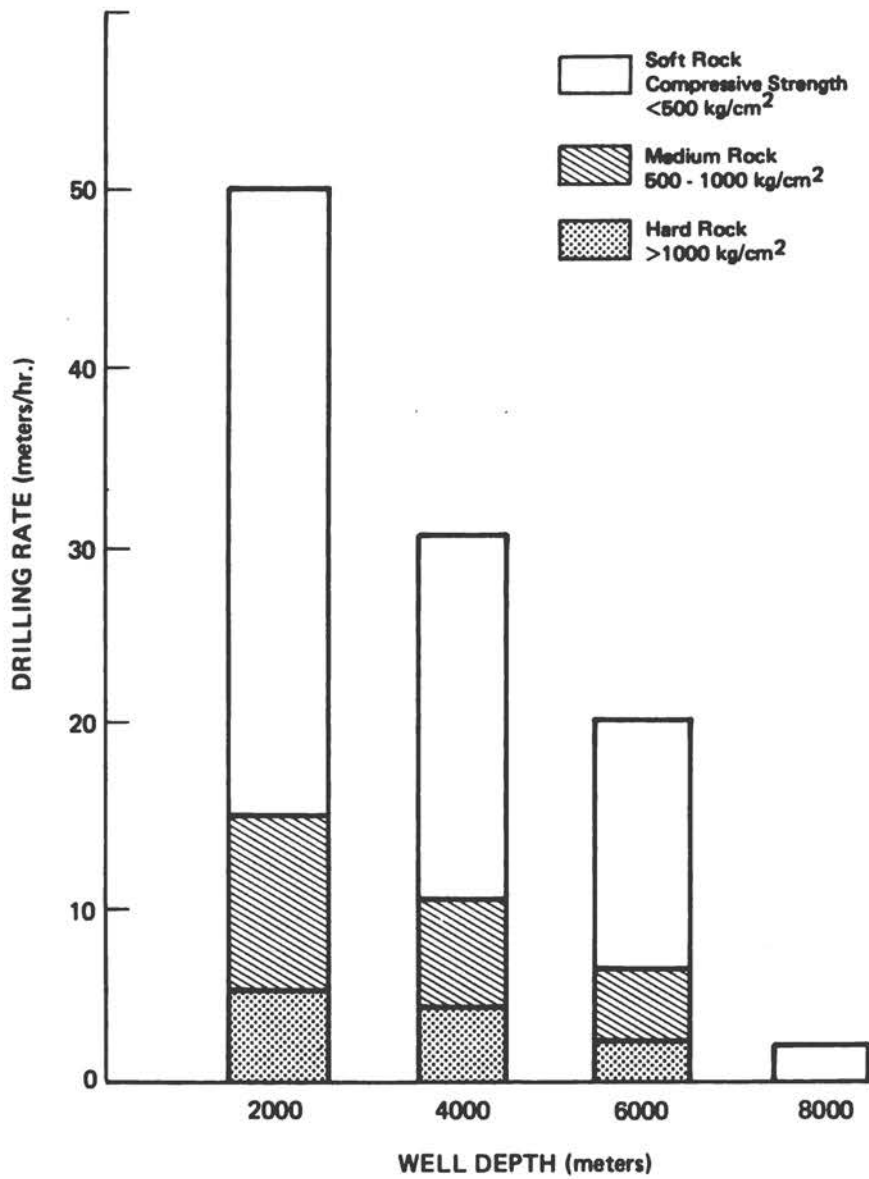

Maurer, 1968

Figure 5. Oil and Gas Well Drilling Rate Versus Depth

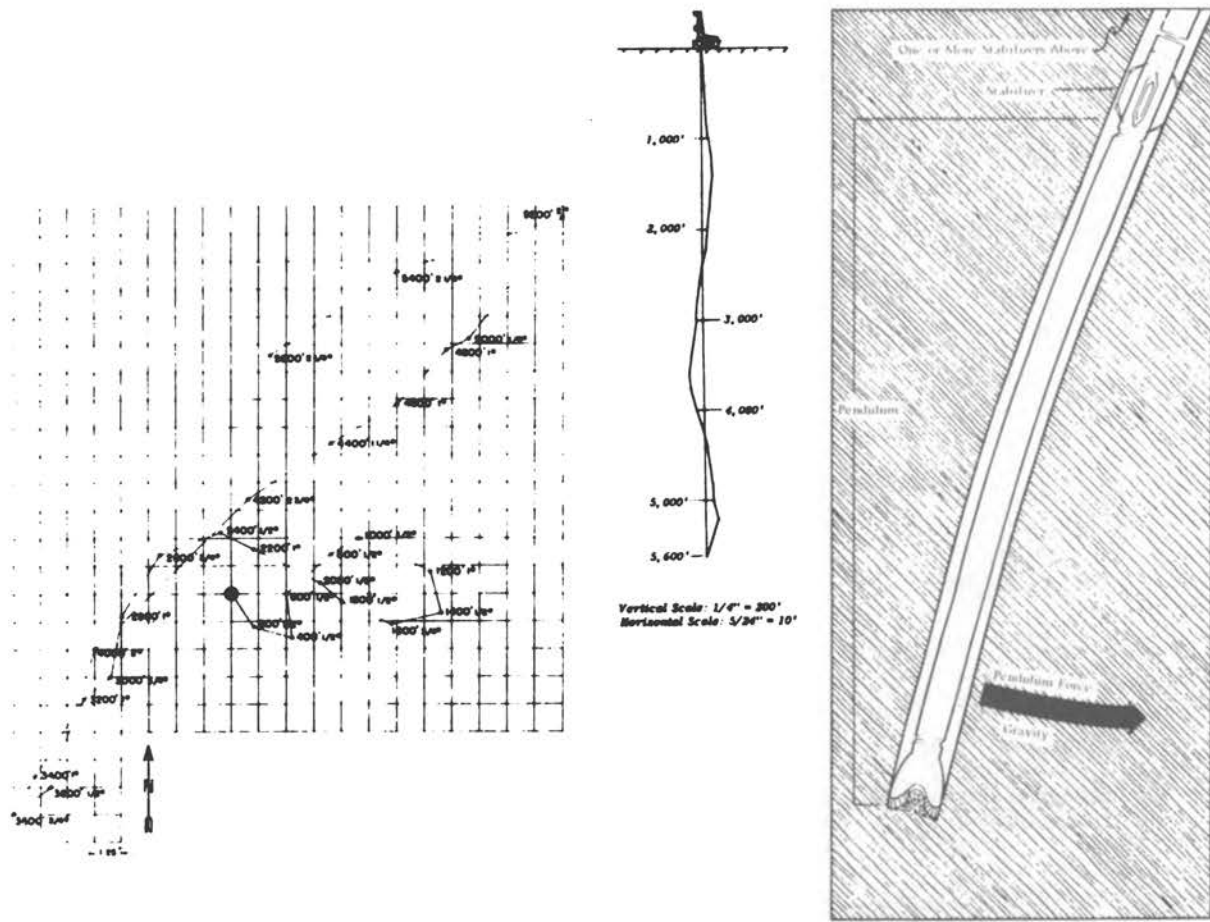

Petroleum Extension Service
 University of Texas at Austin

Figure 6. Typical Pattern of Hole Deviation from Vertical

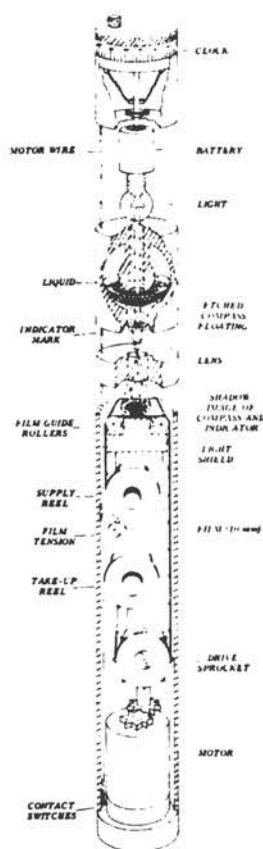

Multishot Survey Instruments with Floating Compass.

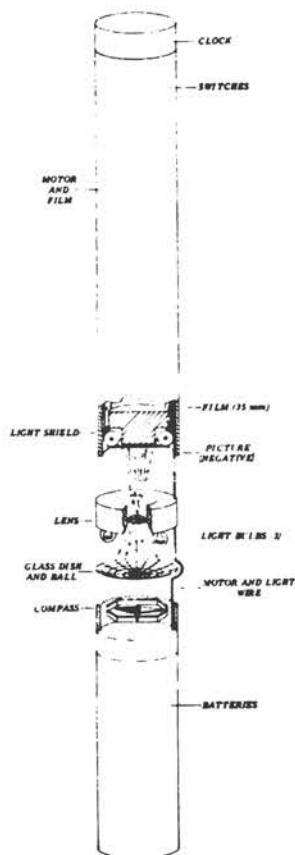

Multishot Survey Instrument with Ball in Dish to Indicate Direction of Deviation

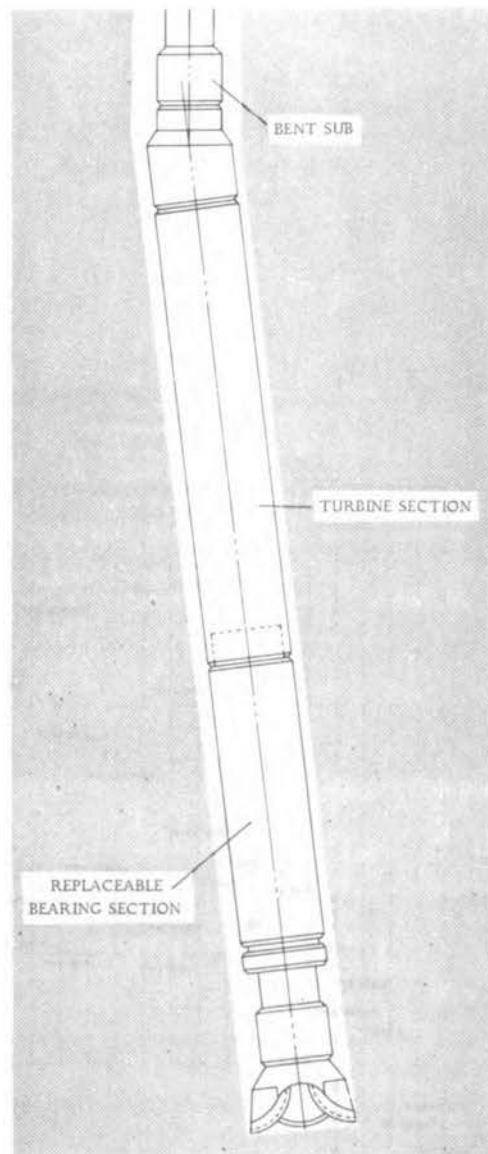

The figure above (left) shows instruments used to survey directionally drilled wells. On the right is a turbodrill with a bent sub assembly which may be used to drill the curved section of directional wells. Below (right) is an illustration of the whipstock method for directional drilling.

Petroleum Extension Service
University of Texas at Austin

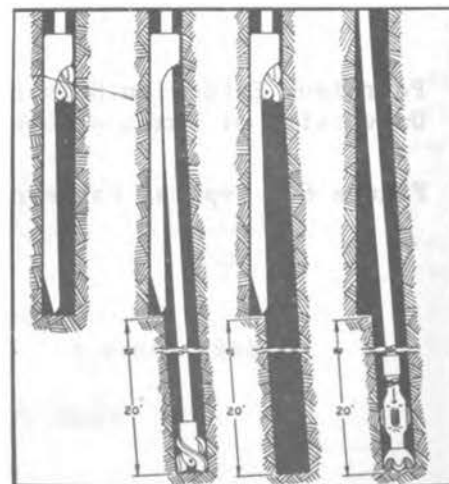

Figure 7. Instruments Used in Directional Drilling

A more current method of directional drilling, also shown in Figure 7, uses a downhole motor or turbine with a 1/2- to 3-degree bent sub and a full-gauge bit. A nonmagnetic drill collar permits the use of magnetic survey instruments (primarily a refined plumb bob and compass system) to indicate inclination and direction. Usually, a survey is made each 30 to 60 feet. An angle buildup rate as great as 5 degrees per 100 feet can be achieved, with a final angle of as much as 70 degrees from vertical (Garrison, 1975).

Crooked holes, collapse of formations, differential pressure sticking in porous formations, and fatigue failures can cause the drill pipe to twist off, leaving a broken section of "fish" in the hole. When this occurs, fishing operations are performed to recover the severed pipe, part of a bit, or other nondrillable materials left in the hole. When a fish cannot be recovered without extensive or uneconomic operations, it may be covered with cement and the hole redrilled or "sidetracked" past the fish.

Testing and Evaluation

Geologists and reservoir engineers use formation rock and fluid samples and measurements that permit determination of formation properties in their evaluations of the potential of a well. The samples and measurements are obtained by coring, drill stem tests, and logging.

Laboratory measurements of the porosity, permeability, and fluid content of cores are used in evaluation of reservoir conditions. Bottom-hole coring is normally done by a bit and tube assembly attached to the lower end of the drill string. However, this method requires a round trip for each 30- to 60-ft core taken. Conversely, up to 30 sidewall cores can be taken simultaneously by a sampler that fires hollow projectiles into the borehole wall, then retrieves the projectiles and samples.

Drill stem testing consists of allowing formation fluids to flow into a special tool attached to the bottom of the drill pipe. In addition to providing oil, gas, or water samples, this procedure also provides pressure data.

Logging consists of making surface recordings of downhole measurements taken by a variety of electrical instruments to evaluate formation lithology, porosity, permeability, and fluid content. The common logs are the electric survey, induction log, acoustic log, and gamma ray and neutron logs (which are radioactivity surveys). A different type of test, mud logging, analyzes the cuttings caught at the shale shaker for indications of the presence of gas or oil.

Well Completion

After a well has been drilled to final depth and logs have been taken, a decision must be made concerning well completion. If the well is not capable of producing oil or gas in commercial quantities, as determined by flow measurements and other tests, it is termed a dry hole and is plugged and abandoned. If the well is capable of commercial production, a final string of production casing is run and cemented in place by filling the annulus around the lower part of the casing with a cement slurry as shown in Figure 8. One type of completion operation then requires shooting holes through the casing and cement into the production zone, using either steel bullets or a shaped-charge explosive fired electrically from the surface.

After the flow path is established, low-permeability carbonate rocks may be "acidized" by pumping acid under pressure into the formation to create greater porosity and permit oil to flow into the well more freely. If the permeability of a sandstone is too low to permit adequate flow of oil or gas, the well may be hydraulically fractured. This operation, called a "frac" job, is performed by forcing a sand and fluid slurry into fractures created by high fluid pressures. The sand grains remain in the formation where they hold the cracks open and thereby improve the formation permeability.

Arctic Drilling

The primary problems associated with Arctic drilling operations concern personnel and logistics (Bartlett, 1975). Because temperatures reach -60°F in winter, all drilling rigs must be completely enclosed and winterized (Figure 9) to protect the equipment and workers. Even then, operations are frequently shut down by "white outs" in which snow, driven by winds of 70 to 80 mph, obscures all outside visibility. In relatively good weather, moving a conventional rig to a new exploratory location can take as long as 60 days because of adverse terrain and low temperatures.

Arctic drilling technologies are similar to those described for onshore oil and gas well drilling. The primary difference in Arctic drilling is the presence of permafrost, a mostly frozen, unconsolidated gravel system, which may extend to a depth of approximately 2,000 ft (Bartlett, 1975). Rotary drilling rigs generate sufficient heat to melt the permafrost and cause a loss of support for the rig. Pilings are therefore frequently used to support the rigs. A thick layer of gravel is applied prior to moving the rig on location to serve as insulation between the permafrost and the heat from the rig floor. Roads are also built on 5 to 6 ft of gravel to prevent thawing of the underlying permafrost.

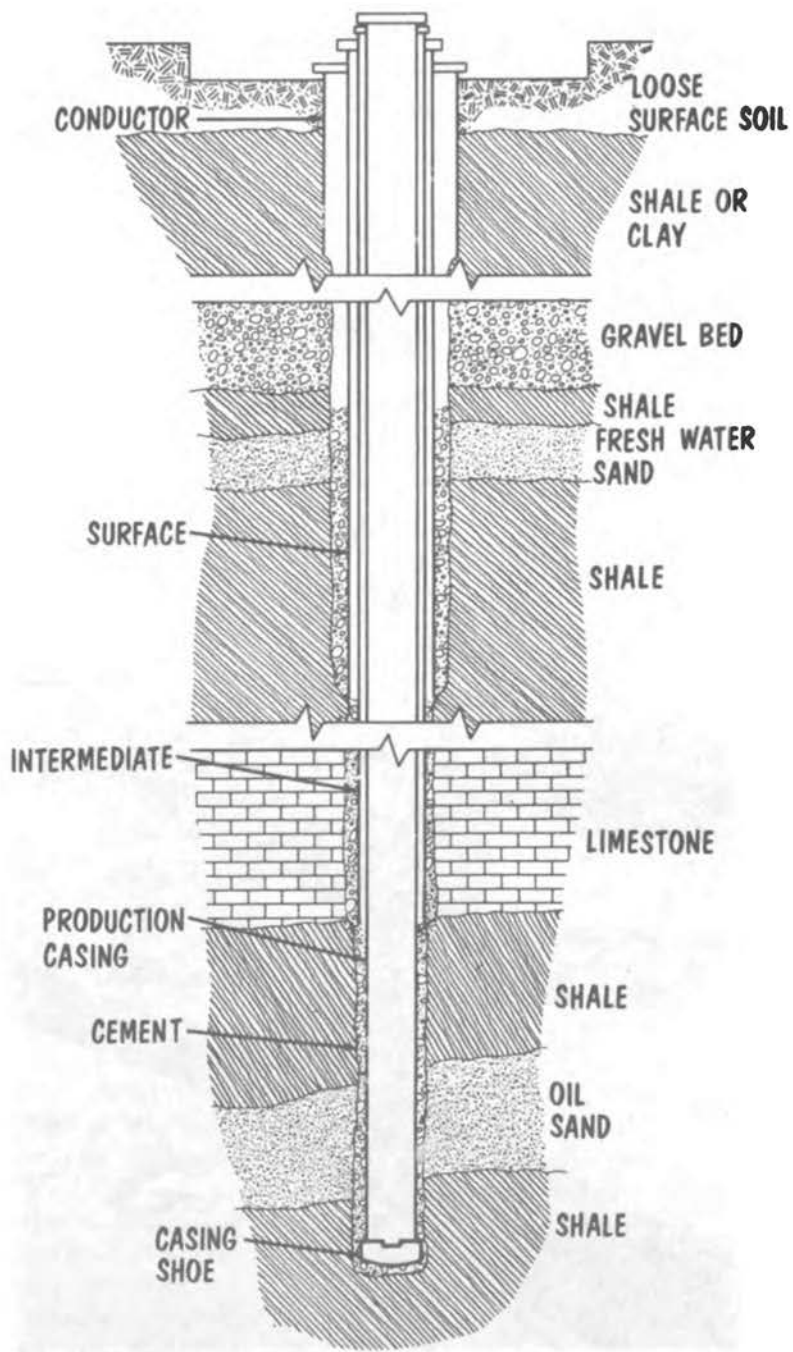

Petroleum Extension Service
University of Texas at Austin

Figure 8. Casing Strings and Pipe Used in an Oil Well



Figure 9. Cook Inlet Monopod

Offshore Drilling

Offshore drilling technology has evolved from an extension and modification of onshore drilling procedures and techniques (Blenkarn, 1975; Geer, 1975). The basic difference is that a support platform must be provided offshore. The first specially constructed steel structure for offshore drilling was built in 20 ft of water in the Gulf of Mexico in 1947. Currently, there are approximately 2,800 fixed platforms world-wide in water depths to 400 ft. Because exploratory wells rarely achieve commercial production, drilling companies cannot afford to construct a fixed platform at each well site. Thus, the industry has developed mobile offshore drilling structures such as the jackup barge (Figure 10), which is supported by the ocean floor, and floating platforms and ships (Figure 11).

Exploratory units have drilled in water depths exceeding 2,000 ft, and several new rigs under construction are designed to operate in 3,000 ft of water. Ocean floor sediment cores and hard-rock samples have been obtained by the drilling ship Glomar Challenger in water depths of over 20,000 ft as part of the Deep Sea Drilling Project (Petroleum Engineer International, Sept. 1975). Drilling rigs on the larger exploratory units are rated for hole depths of 25,000 ft (Petroleum Engineer International, Oct. 1975). Operating costs of these units range from \$12,000 to \$70,000 per day.

The single most important item in a floating drilling system is the marine riser (Figure 11) which conducts the drilling fluid from the sea floor to the drilling vessel. A deep-water riser can cost as much as \$2 million. The riser is in constant danger of buckling because it lacks sufficient strength to support itself and is subjected to pull from the ship and ocean currents. Tensioning devices on the vessel can pull on the riser with axial forces of 50,000 to 150,000 lb, but even this is insufficient to support the longer risers. When a long riser is used, 54- to 60-in. diameter flotation members may be distributed along the riser to provide positive buoyancy. However, should the ball joint at the seafloor blowout preventer fail, the positive buoyancy can cause the riser to float to the surface and cause possible damage to the surface unit.

When storm conditions threaten, the riser must be retrieved and stored on the vessel. Further, this operation must be performed before the sea becomes rough, because of the difficulty in pulling the riser up in heavy seas. Thus, at times, operations are secured in anticipation of severe weather that does not materialize. This unproductive time contributes to the overall cost of drilling from floating vessels.

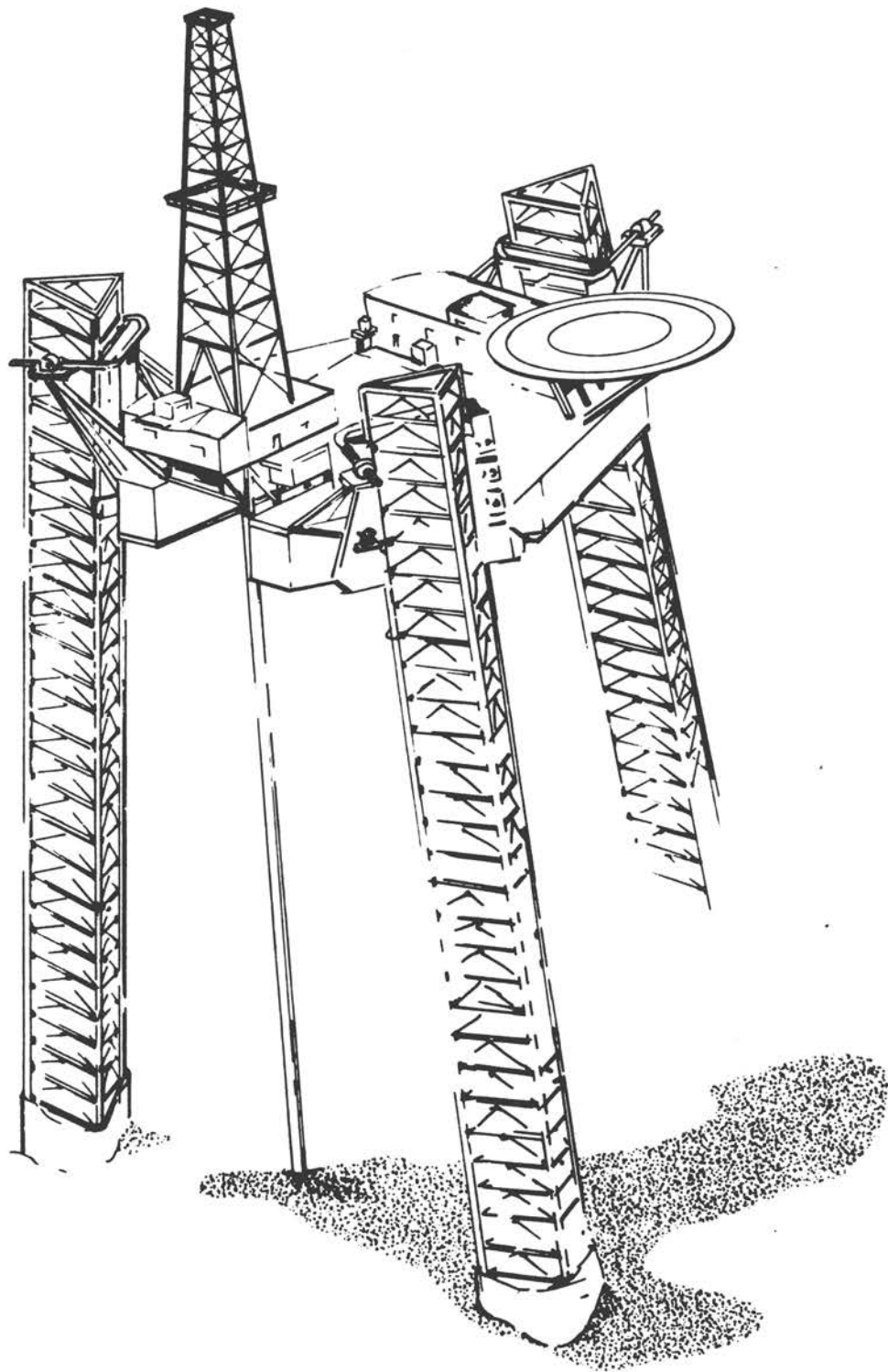

Figure 10. Mobile Drilling Platform

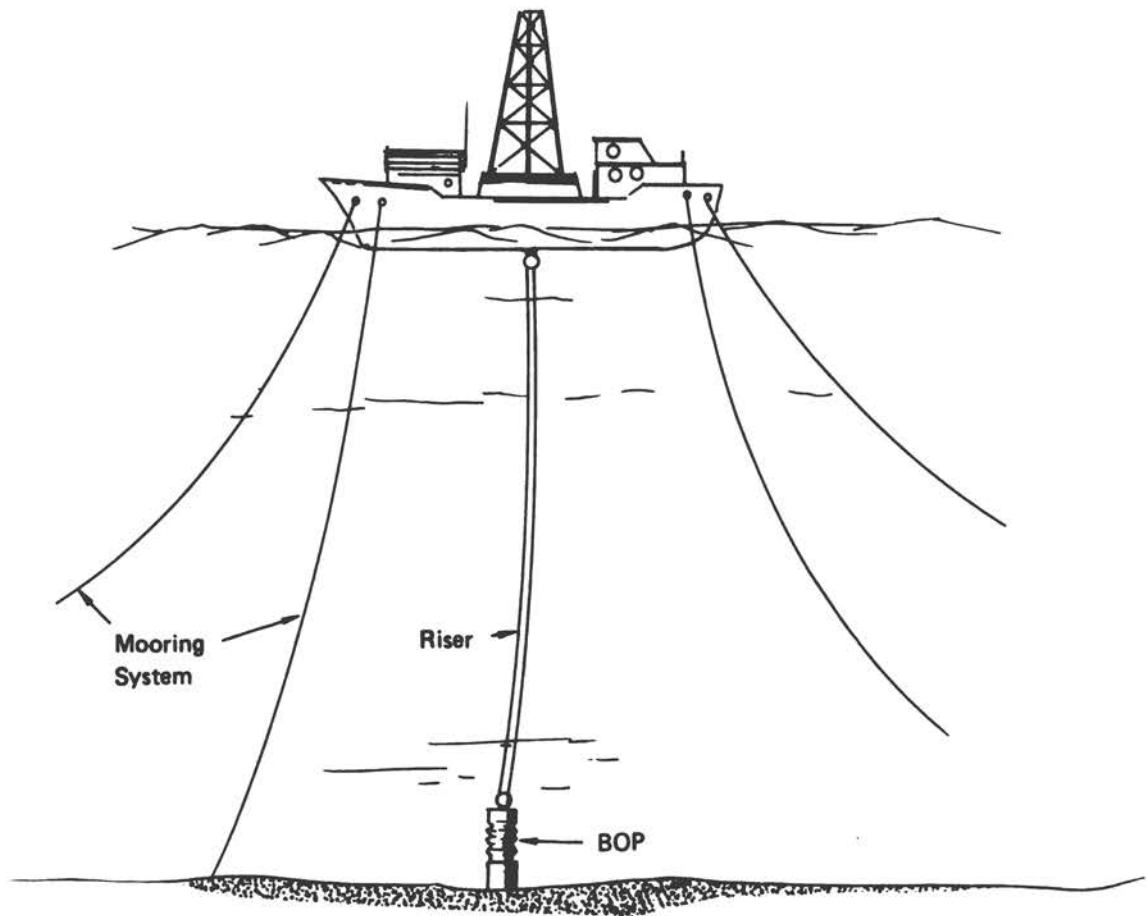

Figure 11. Floating Drilling Ship

The influx of high-pressure formation gas into a well while drilling is normally prevented by the use of a drilling mud with sufficient density to counterbalance the downhole formation pressure. However, if the mud pressure gradient becomes too high, the hole walls will fracture, causing a loss of the drilling fluid and creating difficulties in balancing the high bottom-hole gas pressure. Offshore, the pressure-versus-depth relationships are altered by the overlying depth of water. As the water depth increases, the amount of initial open hole that can be drilled without setting casing decreases. These conditions can be handled by drilling the first 1,000 to 2,000 ft of hole without return of fluids and cuttings to the vessel (i.e., seafloor return). This technique can permit drilling from floating vessels that could not be done with conventional circulation.

Development drilling is normally done from fixed platforms, but occasionally from man-made islands. Up to several dozen wells may be drilled from a single platform depending on the oil reservoir and water depths. One platform is being constructed for water depths to 1,000 ft. These platforms must be designed to withstand forces imposed by winds, waves, currents, ice flow, and earthquakes.

Work currently in progress to develop submerged well heads and production systems could offer an alternative to the use of platforms for drilling production wells.

Geothermal Drilling

Geothermal resources are defined here as the effluent of wells drilled for the purpose of producing either in situ superheated fluids or injected fluids. These resources include wet, dry, and injected steam, as well as in situ, abnormally pressured hot water.

Currently, Italy, New Zealand, Japan, Mexico, and the United States have active geothermal projects. In the United States, approximately 100 geothermal wells have been drilled in the West. The known geothermal reserves consist of approximately 1,500 megawatts electric (Mwe) in the Geysers area of California and larger quantities in Imperial Valley, California, Valles Caldera, New Mexico, Roosevelt, Utah, and other areas of the western United States. ERDA has established a goal of 8,000 Mwe of equivalent energy production from geothermal resources by 1985,--a goal that, if realistic, would require the drilling of 3,000 to 5,000 new production wells.

The formations encountered in drilling geothermal wells are of two varieties: sands of primary porosity, and fractured, hard, abrasive igneous

rocks. In the igneous formations, the usable life of the best hard-rock bits with tungsten carbide teeth may be 200 ft or less. Thus, using current technology, a geothermal well in igneous rock may take 50 days to drill, compared to 18 days for an oil or gas well of equal footage. Thus, more rigs may be required to drill geothermal wells than equivalent oil and gas wells, if the igneous resources are exploited, during an equal time period. Further, increased material and labor costs have doubled the cost of a geothermal well during the last two years to \$300,000 to \$600,000 per well, depending on rock types and depth requirements (Jet Propulsion Lab Report, 1975).

In addition, geothermal formations normally subject the downhole drilling components, such as bits, seals, packers, drilling fluids, and cements, to temperatures greater than those normally experienced in oil and gas drilling, which are usually 350°F or less. Although these temperatures greatly reduce the length of equipment life and have other deleterious effects, conventional drilling techniques and equipment are used where downhole temperatures do not exceed about 500°F.

Coal, Uranium, Oil Shale, and Tar Sands Drilling Technology

Drilling for the recovery of coal, uranium, oil shale, and tar sands requires different equipment and techniques from those needed for oil and gas.

Role of Drilling in Coal Mining Operations

Surface and underground coal mining requires a wide variety of drill holes for many different purposes. These holes range in length from a few inches to more than a mile, and in diameter from less than 1 in. to as large as 25 ft. The smaller holes are used for rock bolts to provide ground control in underground mines, for coring, for drainage, and for blast-holes in both surface and underground mines (Hustrulid, 1975). Large holes are normally used for access and ventilation shafts in underground mining.

Small Hole Drilling

Small holes, of 1 to 6 in. in diameter, are drilled by percussive, rotary, or rotary-percussive machines. The percussive drills remove rock by making a series of indentations, the rotary drills by a planing or cutting action, and the rotary-percussive drills by a combination of indenting and

cutting. All these machines operate on pressure supplied by an air compressor or hydraulic pump driven by an internal combustion or electric power source. The energy is transmitted by the drill rod to the bit. Fluid is used to remove the cuttings from beneath the bit, although it may not flow through the drill rod as it does in large drill strings.

The percussive drilling machine contains a piston that is driven by air or hydraulic fluid. The piston impacts on the steel drill rod which transfers energy to the bit to produce rock breakage. The piston then moves back up the cylinder and the bit is rotated for the next blow. For shallow holes of less than 4-in. diameter, percussive drills are used predominantly in all materials, and are used exclusively for hard-rock drilling. A small percussive drill is shown in Figure 12.



McGahan and Adams

Figure 12. Small Percussive Crawler Drill

Rotary drills, which combine high thrust with bit rotation, are used primarily in soft, nonabrasive materials. If the thrust is not sufficient to produce penetration, the rotation only produces abrasion between the bit and the rock without generating the large chips necessary for effective drilling.

Rotary-percussive drills deliver a percussive blow superimposed on the rotary drilling action, combining the advantages of rotary drills with the hard, abrasive rock drilling capabilities of percussive machines. The potential of the rotary-percussive machine was described in 1955, but little progress has been made in the United States since to realize its potential (Hustrulid, 1975). Although some U.S. companies produce rotary-percussive drills, the straight percussive drill is much more extensively used, especially in hard rock and underground mining.

Comparisons of the drilling speed of the three types of drills are not generally available because they are seldom used to drill the same type of rock. Instead, a particular drill is selected to suit specific rock conditions. Typical penetration rates for mounted and power-thrusted drills for 1-1 1/16-in. diameter holes are:

Percussive:	55 in./min in granite
Percussive:	125 in./min in dolomite
Rotary-percussive:	90 in./min in dolomite
Rotary:	60 in./min in shale

The overall efficiency of the pneumatically driven percussive rock drill depends on the efficiencies of the individual components. Air compressors have efficiencies of about 70 percent, but less than 25 percent of the available energy is transformed into kinetic energy of the piston in its forward stroke and only about 80 percent of this, in turn, is transferred to the rock. Thus, the overall efficiency from the electrical energy input to the final rock breakage is about 9 percent. Currently available hydraulic drills have considerably greater efficiencies than air drills because of the incompressibility of the fluid and the closed loop fluid system.

Blast-Hole Drilling for Surface Mining

Open-pit and area surface mines often require that overburden be fractured by blasting for efficient removal. Typically, overburden blast-hole diameters range from 12 to 15 in., as compared with 3 to 6 in. in coal

mines. If the overburden is composed of light shales or soft rock, the blast holes are usually drilled with drag bits. Roller-cone bits are used in harder formations and for larger holes. Percussive bits are used in very hard abrasive formations. A typical rig for drilling 15-in. diameter blast holes weighs 250,000 lb and requires a 750-hp engine to drive its 2,000-cfm, 55-psi compressor. The thrust capability of such a rig is 120,000 lb.

Typical costs of overburden blast holes range from \$.54 per ft for 6-in. diameter holes to \$1.15 per ft for 15-in. diameter holes. These costs represent less than \$.30 per ton for a typical coal strip mine. In 1973, an estimated 112 million ft were drilled in coal overburden at a cost of \$90 million. The corresponding estimates for 1985 are 261 million ft at a cost of \$210 million (McGahan and Adams, 1975).

Horizontal and Directionally Drilled Holes

Long horizontal holes are drilled for exploratory purposes (such as geological mapping prior to driving tunnels), for mine access and ventilation, and for water and coal gasification drainage (Dowding, 1975; Harding, 1975). These holes vary from less than 3 to 12 in. in diameter. The longest horizontal hole to date (6-3/4 in. in diameter and 5,300 ft. long) was drilled for a tunnel project in Japan during 1971-1972. A current wire-line horizontal coring project in South Africa is expected to be drilled to 5,000 ft using a 2.36-in. core drill. Horizontal holes are guided by surveying and steering, using such oil and gas drilling techniques as the magnetic survey instrument and either whip-stocks or downhole motors with bent subs. The costs of long horizontal holes can vary from approximately \$10 to \$80 per ft, depending on such factors as hole size and total length to be drilled.

Techniques for drilling curved holes vertically from the surface into horizontal coal beds are being developed for use in the in situ coal gasification processes. Underground ore-sampling experiments have used 4-in. diameter holes drilled with a 125 ft radius arc from the vertical to the horizontal (Letter, H.V. Sears to J.B. Cheatham, Oct. 3, 1975).

Large-Hole Drilling

Holes to 25 ft in diameter are drilled for hydroelectric power development and underground mining (Robbins, 1975). These holes include vertical shafts from the surface, vertical and inclined raises driven upward

to the surface or between mine levels, and tunnels for development haulage ways, ventilation shafts, and production development areas.

Blind-hole shaft drilling uses oil-field techniques and equipment scaled up to drill 8- to 12-ft diameter holes. Muck is removed by reverse fluid circulation up the center of the drilling string. The practical upper limit for this technique appears to be 12-ft diameter holes for depths exceeding 2,000 ft. Figure 13 is a schematic drawing illustrating blind-hole drilling.

Raises (holes drilled upward) to 14 ft in diameter are currently bored through more than 2,000 ft of hard rock. Recent improvements in raise head and cutter designs have often made raise-drilling costs competitive with conventional raise-blasting techniques. Also, raise drilling has significant speed and safety advantages over blasting. Figure 14 shows a raise boring machine.

Up-reaming consists of drilling a small-diameter pilot hole from the surface into the underground mine workings and then reaming a large diameter hole upward (see Figure 15). Tension in the drill pipe is provided by the drilling rig at the surface, and the pilot hole stabilizes the drill pipe along its entire length. Cuttings fall into the opening below and are handled by conventional mining methods. Where up-reaming can be used, it is the most economical method of drilling large-diameter holes. Up-reaming of a 9-ft diameter hole has been performed from a depth of 1,155 ft (Reed Mining News, Jan. 1976).

Tunneling equipment which is small, lightweight, mobile, and mechanized is available for cutting openings of varying size and shape in soft rock and coal, but has not performed successfully in moderately hard, abrasive rock. All hard-rock mechanized tunneling has been achieved by applying very high loads on rolling cutters to crush the rock at the tunnel face. These hard-rock rolling cutters require rigid mounting on a cutterhead which is well-centralized and stabilized against the lateral forces resulting from the cutting action. The modern hard-rock tunnel boring machine is an efficient tool for boring long tunnels with large radius curves, but it cannot be used to cut stopes, crosscuts, inclines, and declines (Robbins, 1975).

Mining Systems

Continuous-mining machines perform both cutting and loading operations and eliminate the need for blasting of the mine face (Carnegie-Mellon University, 1973), thus increasing productivity and reducing dust

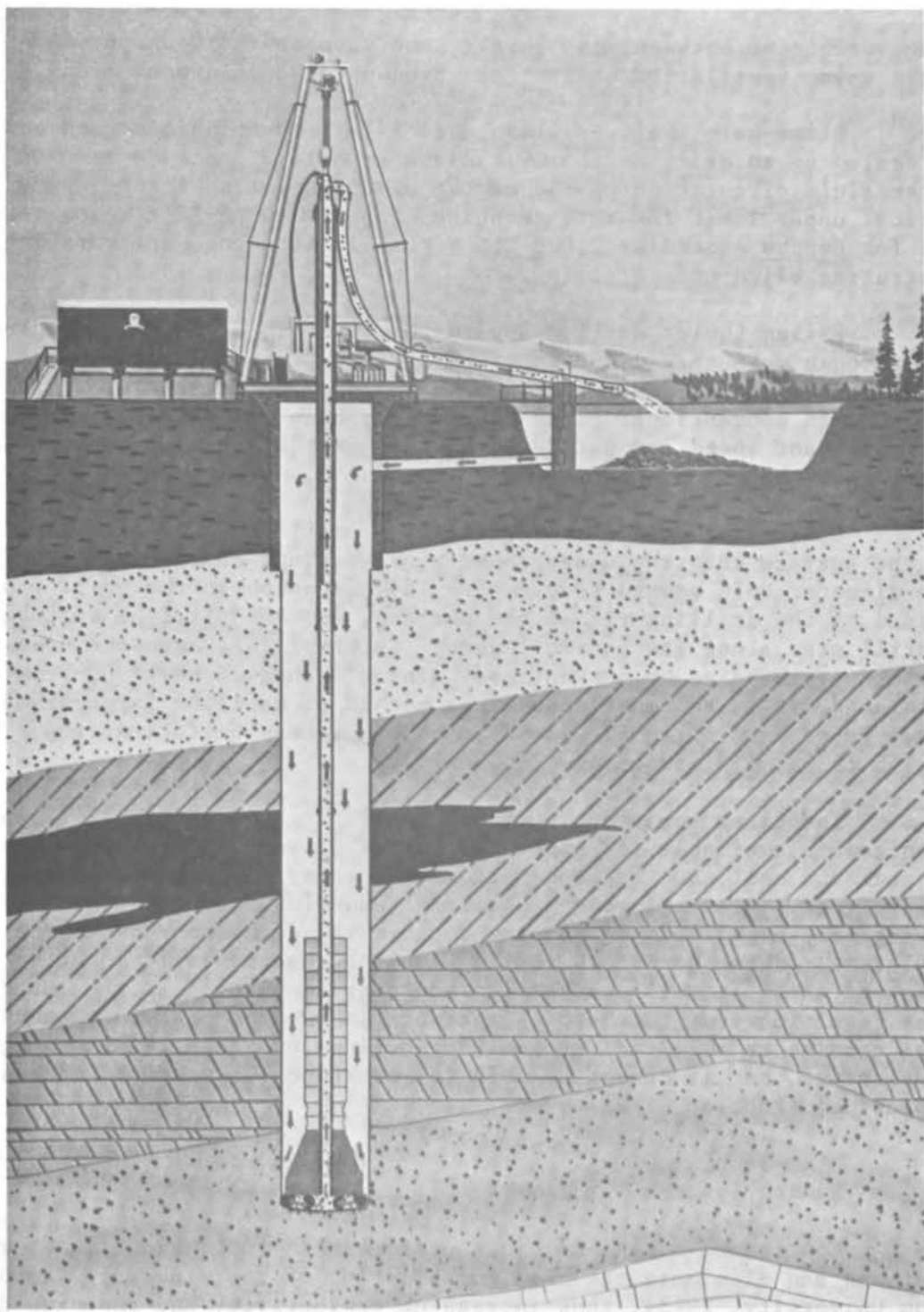

Teton Exploration Drilling Co., Inc.

Figure 13. Schematic Drawing of Blind-Hole Drilling

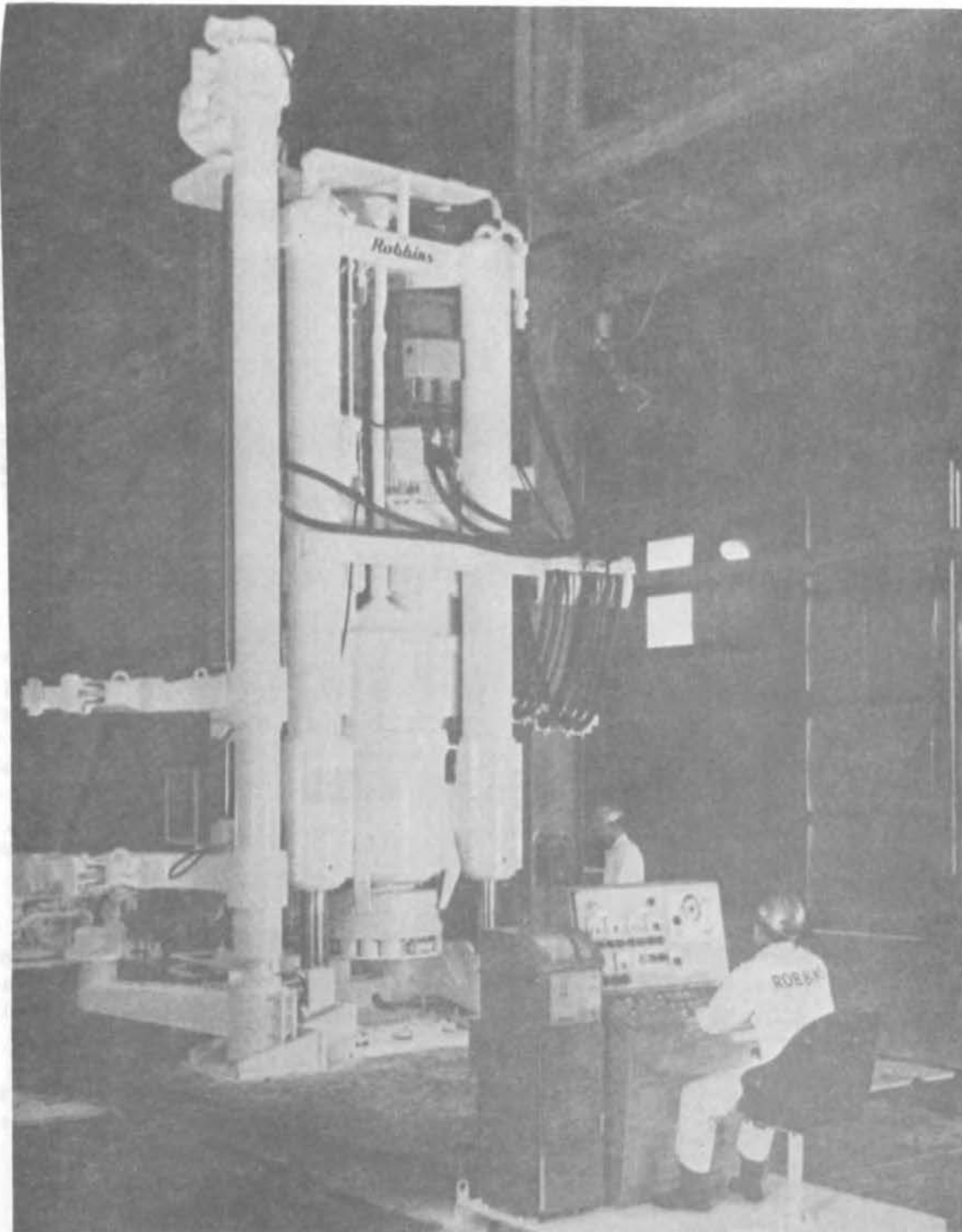

Teton Exploration Drilling Co., Inc.

Figure 14. Raise Boring Machine

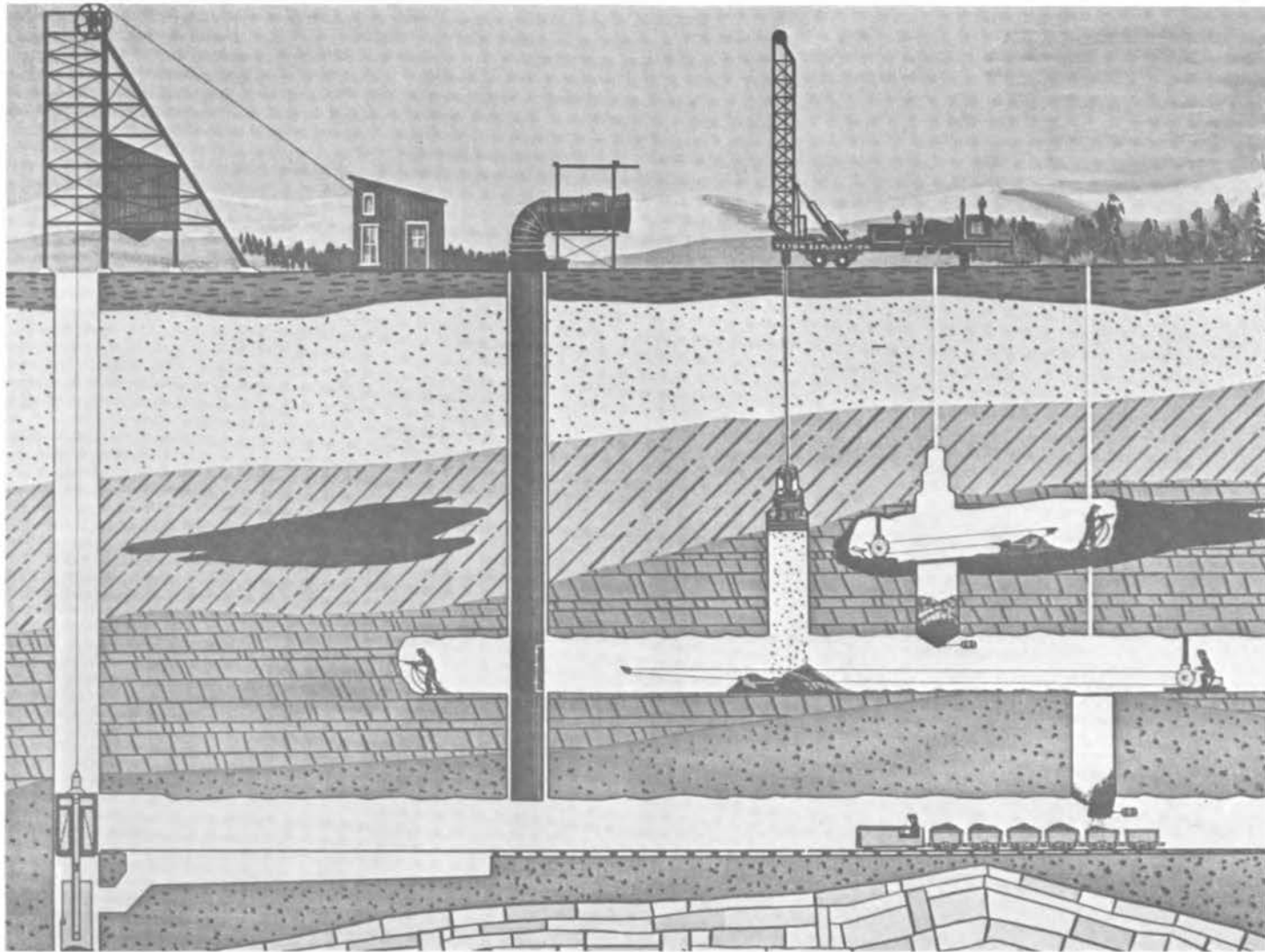

Figure 15. Schematic Drawing of Up-reaming

Teton Exploration Drilling Co., Inc.

and maintenance problems compared to conventional mining procedures. Continuous miners, which could potentially double productivity while reducing labor and material costs, are most efficiently used with the longwall mining system. Used primarily for extracting coal, longwall mining consists of establishing a relatively long seam face across which the continuous miner moves back and forth, shearing coal from the seam and loading it onto conveyors or carts. No roof-support pillars are left, as in the more common roof-and-pillar coal mines. The workers are protected by a hydraulically operated steel roof support, which is moved forward as mining progresses. The mine roof is allowed to collapse behind the support.

Although the predominant system in Europe, few coal mines in the United States use the longwall method because it requires much greater capital investments and because of differences in American and European coal seams. However, longwall mining can significantly improve mine productivity at lower depths, as well as leave less of the resource in place (Carnegie-Mellon University, 1973).

Drilling for Uranium Production

Uranium mining companies have essentially followed the mining practices developed for other metals and coal. However, uranium mines are generally quite small, compared with coal and metal mines, and the mining methods are slow and inefficient. Approximately equal quantities of uranium ore are produced from surface and underground mines (McGahan and Adams, 1975). Total production in 1974 was nearly 12,000 tons of uranium ore in concentrate. That same year, exploratory, development, and production drilling totaled approximately 22 million ft--90 percent of this footage in holes of less than 2,000 ft deep.

In uranium mining, most of the overburden is broken by ripping--only about 8 percent of the rock is drilled or blasted. However, a large amount of drilling is done at surface uranium mines to assess the potential of each area of the mineral deposit. These holes, typically about 5 1/2 in. in diameter, are normally drilled by blast-hole rigs.

Underground uranium mines have the continuous problem of hazardous radioactive materials and radon gas. Radon gas contamination is currently controlled by the extremely costly process of spraying the walls with chemicals and by greatly increased air ventilation.

Drilling for Oil Shale and Tar Sands Production

Oil shale development foresees the use of both underground and surface mining, and possibly in situ retorting methods. Tar sands development will be dominated by heavy oil stimulation techniques. For both these resources, the present exploratory drilling, coring, and logging techniques should be adequate.

Tar sands drilling for production operations has the same problems as conventional petroleum drilling. Again, present technology should be adequate.

Oil shale production from surface mines will be limited to relatively small geographic areas where formation thickness approaches 1,000 ft and the overburden ratios are 1 or less. Open-pit technology, as practiced in the copper industry, appears applicable. Although the scale of operations will be large and the amount of drilling for the placing of explosives extensive, present technology is applicable and efficient.

Underground mining of oil shale will use room-and-pillar techniques to mine high-grade zones varying from 50 to 150 ft thick. Drilling will be required for the placing of explosives and roof bolts. The necessary special drilling equipment already has been developed during the past 25 years by both the government and industry. Although current technology is adequate, improvements are anticipated when oil shale mines become operational. Drilling costs are one of the less important factors in the economics of shale oil production.

In situ shale oil production concepts envision both modification of many current oil field practices (for example, drilling, fracturing, fluid injection, and fire-flooding) and mining to prepare a rubble chimney for underground combustion. No new drilling techniques are required.

Machines that can bore large shafts of up to 25 ft in diameter have been suggested for mining oil shale. Small-scale tests have been promising, but the cost of building and testing an operable machine has inhibited further development. Existing tunneling and raise-boring machines will be adapted to oil shale when production is initiated.

CHAPTER 3

TECHNICAL LIMITATIONS, OPPORTUNITIES, AND RECOMMENDATIONS

In reviewing current drilling technology, the committee examined drilling as a system and identified high-leverage areas where improvements would have maximum effect. These areas may be limited by nontechnical as well as technical factors, but the technical opportunities are sufficient to make significant gains possible even if the non-technical limitations do not change.

When formulating its recommendations, the committee attempted to ensure that the proposed R&D efforts to be funded by the government both supplemented and complemented current or planned industry efforts. The intent was that proposed government actions would not compete with private programs, but would strengthen and expedite them. Basically, the committee's attitude was that industry should continue to perform the bulk of the drilling R&D efforts--government-funded work should be confined to areas where industry does not plan to or is not capable of supporting the levels of effort needed to achieve significant results in the near future. Time and again throughout this study, the committee noted that close industry-government cooperation was needed to prevent government funding from causing reductions or curtailments in industry programs. This could occur if a company adjusted its planning to take advantage of government funding that failed to materialize in a timely way.

Oil, Gas, and Geothermal Limitations and Opportunities

For the rotary drilling equipment and techniques used for oil, gas, and geothermal energy recovery, the most significant improvements will be those that decrease the time that the rig is not drilling. Current estimates are that operating time spent in actual drilling is only about 40 percent for

all onshore wells and 25 percent for all offshore wells, where more directional drilling occurs (Hammett, 1975). A time distribution analysis of well drilling in Texas and Louisiana is shown in Table 4. In directionally drilled holes, equal time is commonly spent in drilling and surveying.

The overall drilling rate is reduced by such necessary operations as drill stem testing, mud conditioning, surface equipment maintenance, running casing, coring, logging, etc. Additionally, drill pipe fatigue failures, worn out bits and bearings, and similar equipment problems also limit productive drilling time. Thus, equipment or technique improvements that reduce nonproductive drilling time will increase the overall drilling rate.

Improvements in the instantaneous drilling rates will also improve the overall drilling rate. In directionally drilled wells, instantaneous drilling rates are often reduced by friction drag of the drill pipe on the side of the hole. Vertical wells with deviation problems can suffer reduced drilling rates because of the need to reduce bit forces when using the pendulum effect (See Figure 5).

Generally, instantaneous drilling rates increase with increased bit force and rotary speed. Thus, instantaneous drilling rates can be increased by equipment or technique improvements in such areas as bit design, drilling mud properties, and circulation conditions.

In addition to the overall and instantaneous drilling rates, the total annual footage drilled depends on two major factors: the number of rigs available and the trained personnel to man them. At the end of 1975, only about 1,800 rotary drilling rigs were available for drilling oil and gas wells, and almost all of these were in use. The facilities for manufacturing new rotary rigs are limited, and the delivery time of some rig components is as long as three years. Thus, any immediate, substantial increase in the total annual footage drilled must result from improvements in the overall drilling rate.

Furthermore, only about 6,300 drillers, 2,000 toolpushers (supervisors), and 500 engineers were in the trained-labor pool for drilling oil and gas wells during 1975, and essentially all of these were employed. Thus, any substantial increase in the number of rotary drilling rigs available will result in a shortage of trained personnel to operate those rigs unless appropriate training programs are developed concurrently with rig manufacturing.

Table 4. Time Distribution Analysis for Well Drilling.

REGION	WEST TEXAS		TEXAS COAST		OFFSHORE	
STATE	TEXAS		TEXAS		LOUISIANA	
COUNTY	REAGAN		JEFFERSON			
TOTAL DEPTH, ft.	7550		11043		12280	
ROCK BITS USED	5		14		20	
	<u>TIME: DAYS (%)</u>					
DRILLING	17.0	(89.3)	16.3	(29.0)	10.8	(21.6)
TRIPS	0.7	(4.0)	11.7	(20.8)	12.8	(25.5)
RUNNING CASING, CEMENTING, WOC	0.3	(1.5)	4.3	(7.7)	1.2	(2.4)
<u>OTHER</u>	<u>1.0</u>	<u>(5.2)</u>	<u>23.9</u>	<u>(42.5)</u>	<u>25.3</u>	<u>(50.5)</u>
	19.0	(100.0)	56.1	(100.0)	50.2	(100.0)
RIG COST/DAY	\$3100		\$3400		\$5700	

Loffland Brothers Company

One limitation to implementing new technology is the difficulty in field testing new equipment and procedures. Because of the high costs of such programs, the financial risks are frequently greater than any one private company can afford to take. A cooperative effort is probably needed to overcome this limitation.

Another difficulty is that private industry may not have adequate incentives for development of new drilling technology requiring large investment. This is because the drilling services are provided principally by independent companies, which include companies of relatively modest financial resources. The energy resource companies have limited incentive since any innovation would be available to all in the industry by means of the drilling firms. Therefore, novel or high-cost research and development may require government support.

Drilling rigs which automatically handle drill pipe are currently being developed by industry. These rigs offer the promise of reducing the time required for round trips and other drilling procedures.

The development of reliable downhole telemetry systems that transmit data to the surface will allow such advantages as:

- Surveying and logging while drilling.
- Measurement of downhole drilling parameters, such as bit force, torque, and rotary speed.
- Detection of incipient bit bearing failure.
- Early detection of gas influxes that could lead to blowouts.

At least 14 companies currently have active development programs aimed at obtaining downhole measurements while drilling (Heilhecker, 1975; McDonald and Ward, 1975). Government programs on data telemetry should be coordinated to supplement these industry efforts.

The proposals range from mud-pulse systems (Figure 16) to hard-wire telemetry systems (Figure 17) to electromagnetic methods (McDonald and Ward, 1975). Successful downhole telemetry systems will open up a new technology area in oil and gas well drilling. The economic incentives are great, and some systems should be commercially available within about three

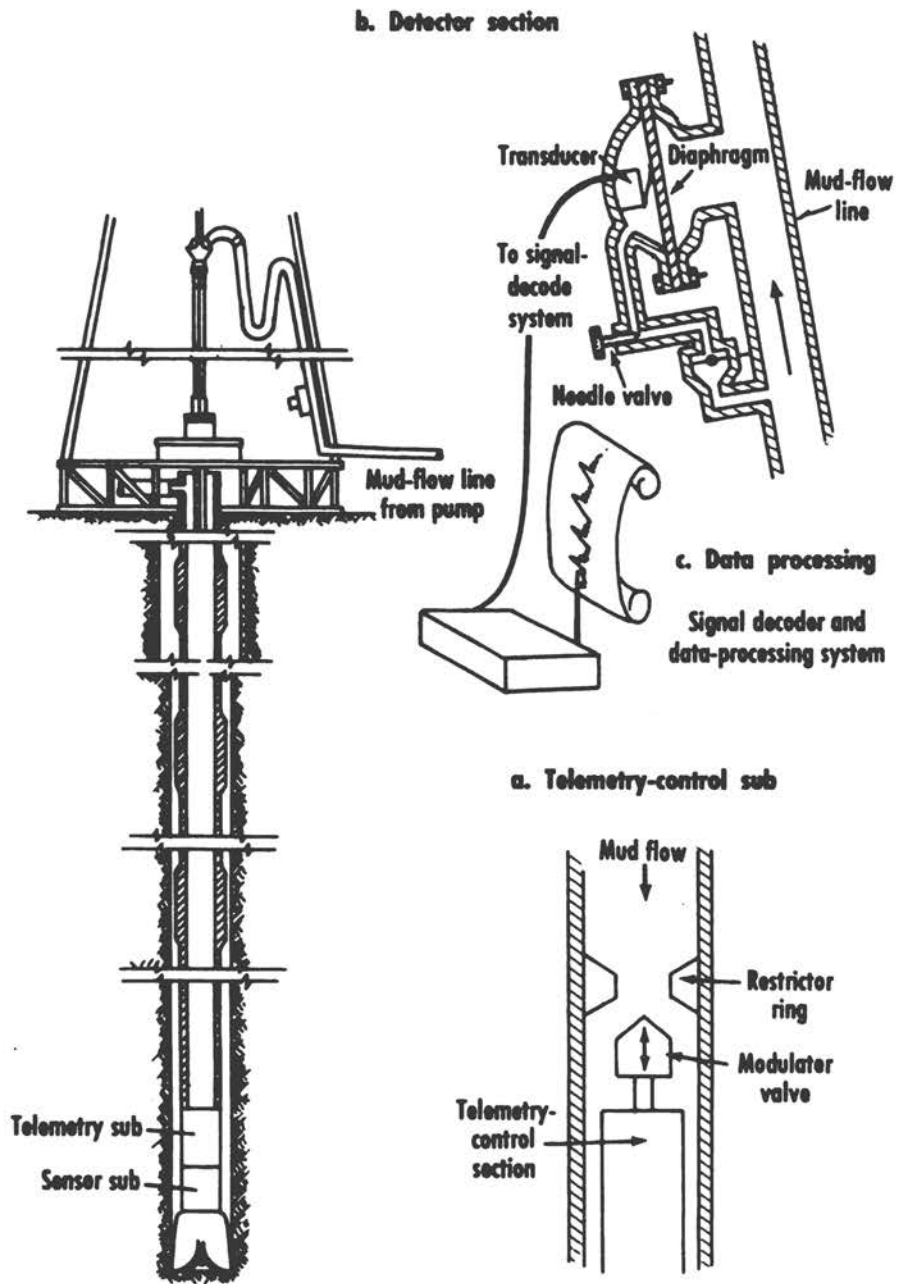

McDonald and Ward

Figure 16. Mud-pulse Telemetry System

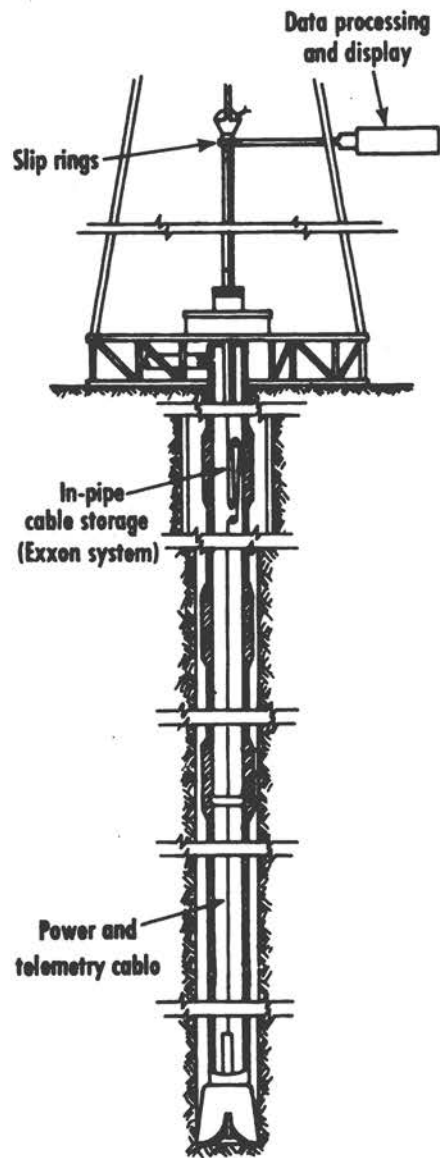

McDonald and Ward

Figure 17. Hard-wire Telemetry System

years (McDonald and Ward, 1975). The development of a reliable downhole communication system will only mark the beginning of far-reaching applications that will influence nearly every phase of drilling activities.

Downhole drilling motors are now used primarily for changing direction in directional wells. They are not used extensively for straight-hole drilling because of their limited motor life. Development of a reliable, long-life downhole motor could:

- Permit the drill pipe to remain stationary, thereby reducing fatigue-failure problems and twist-offs.
- Increase instantaneous drilling rates.
- Reduce drill pipe and casing-wear problems in highly deviated wells.
- Allow the development of a remotely guided drilling system when coupled with a data telemetry system.

Instantaneous drilling rates can also be increased by developing an improved understanding of downhole drilling mechanics. For example, research on drilling mechanics in the 1940's led to the development of jet bits which doubled the then existing drilling rates in the oil industry.

Improved materials could lead to the development of longer life bits, and more reliable downhole tools in reservoirs containing highly corrosive fluids. Specifically, elastomers and improved steels are needed for use in hydrogen sulfide environments and high-temperature geothermal wells.

Offshore Drilling

Problems unique to offshore drilling for oil and gas arise from the necessity for operating at various water depths from fixed or floating platforms. Winds, waves, and currents generated by storms impose large forces on offshore structures. Accurate weather forecasting is necessary to allow sufficient time to permit securing drilling operations to withstand these severe conditions.

The marine riser, which permits fluid circulation between the platform and the ocean floor, is a critical item in a floating drilling system. In particular, there are problems related to the support of deep-water risers. At present, buoyant sleeves are used around the riser, in

addition to tensioning devices. Even with these buoyant sleeves, the amount of tensioning needed in deep water becomes prohibitive if heavy (dense) drilling fluids must be used. Adequate riser design techniques are needed for water depths of 5,000 ft and more.

One technique, considered first in the Mohole Phase II Project and also used in an industrial project currently under way, consists of using lower and upper risers. The lower riser is suspended from a buoy located, for example, 600 ft below the surface. The upper riser is conventional; however, in any case of a break of the lower riser, the buoy could rise and possibly damage the surface unit. Research is being conducted currently to investigate further the design of deep-water risers.

Inadequate technology for predicting, detecting, or otherwise guarding against fatigue failures result in additional operating costs, especially offshore. For example, in some areas associated with marine risers and appurtenances, the costs of failures could total hundreds of thousands of dollars per rig per year. Finally, casing and drill-pipe failures, especially in directional wells, can result in a well having to be plugged and redrilled. Although the industry is making efforts to engineer individual systems with available machine design and materials-usage practices, improved designs to combat fatigue failures are badly needed.

Development of improved riser technology could lead to:

- o Use of smaller, lighter risers permitting smaller drillsnips.
- o Oil and gas production in deeper waters.
- o Safer drilling operation.
- o Increased mobility, thereby increasing overall drilling rates.

All offshore day-to-day operations use short-range weather forecasts with predictions ranging from a few hours to a few days. Operations far from a shore base are particularly dependent on these forecasts. At present, commercial weather services provide forecasts based on government-supplied weather maps and a knowledge of local conditions. Longer range weather forecasting is needed for more efficient offshore drilling operations.

Arctic Drilling

In addition to the general limitations related to drilling described above, the hostile environment of the Arctic causes unique problems. Personnel and equipment must be protected from the cold, and insulation is necessary to prevent thawing of the permafrost under roads and rigs. Casing can be subjected to collapse pressures if the surrounding permafrost thaws and then refreezes. Offshore Arctic structures are frequently subjected to strong forces from ice floe movement, and the disposal of drilling mud and cuttings without damage to the environment is a problem.

Layers of gravel are commonly used as insulation between permafrost and rigs, buildings, or roads. However, adequate supplies of gravel may not be available for future, expanded operations. Industry is currently searching for economical materials that have the strength and insulation properties required to serve as gravel substitutes for foundations on the permafrost.

The cost of drilling Arctic wells is currently high because of the remoteness of the area and because this is a newly developing technology. Consequently, emphasis should be placed on research and development efforts which could have immediate application or reduce costs.

Geothermal Drilling

Current geothermal drilling requirements at temperatures below 500°F are essentially the same as those for high-temperature oil and gas well drilling, and some of the existing drilling technology can be extended to the 500°F limit. However, rubber components in seals, packers, and down-hole motors are limited to maximum temperatures of 300°F to 350°F, and conventional drilling muds and cements are generally limited to temperatures below 350°F. Water or air is frequently used as the drilling fluid when drilling into hot zones. However, the abrasive cuttings in a high-velocity air stream can cause serious damage to the drill string. As much as 50 percent of the drill pipe may have to be replaced after drilling only one well, as in the Geysers (Jet Propulsion Laboratory, 1975).

The fractured rock encountered in geothermal drilling causes a number of problems. These fractures cause deviations and crooked holes that can wear the drill pipe. Directional drilling under these conditions

is extremely difficult. The fractured rock and the presence of under-pressured formation fluid zones cause frequent loss of the circulatory fluid. When encountered, these zones must be sealed to restore circulation before drilling can continue.

Industry efforts are presently limited to providing longer lasting bits for drilling the hard, abrasive rocks and solving downhole fatigue, corrosion, and erosion problems. Industry efforts should also be directed at providing drilling fluids, cements, and downhole tools, and establishing completion techniques for use at temperatures up to 500°F.

Current government funded research efforts are confined to development of novel drilling systems, such as the subterrene drill that melts the rock. This drill, although requiring large quantities of power, is thought to have some potential for drilling in deep, hot dry rocks where conventional drilling systems have significant limitations.

Long-range research and development efforts are required to overcome drilling problems at temperatures above 350°F. Metallurgical studies are needed to combat the fatigue, corrosion, and erosion problems in high temperature drilling. Additional research and development is needed to develop seals and lubricants for use at temperatures greater than 350°F and to provide drilling fluid and cementing systems for use at temperatures in excess of 400°F. Exploratory projects are needed immediately to reduce the lead time required to solve these long-range problems.

Like Arctic drilling, geothermal drilling is a newly developing technology. Consequently, R&D is needed and could produce rapid results in increased productivity and reduced drilling costs.

Recommendations for Oil, Gas, and Geothermal Drilling

All of the following recommendations are based on the assumption that the individual programs under review are using groups and procedures described in the implementation discussion in Chapter 4. The federal funding that is considered necessary to advance drilling technology should be dependent on the detailed government/industry arrangement. The committee holds that the dollar sums for this effort are only indicative of the magnitude that is judged to be helpful. In some cases, substantially more federal money may be required to assure a successful program.

Downhole Telemetry Systems

Industry has developed and commercialized telemetry systems. The fact that it is continuing this development is supported by at least 14

companies that are currently working on such systems. Government support of telemetry R&D should supplement industry efforts and provide funds for testing these systems.

The committee recommends that the government spend \$5 million to \$10 million on the development and demonstration of downhole telemetry systems over the next five years.

Testing and Evaluation

The process of applying new technology involves substantial risks, which the government would do well to help underwrite. Test facilities at laboratories, field sites, or standard and offshore rigs, need to be made available for the use of industry, when needed, to test and evaluate new equipment, instrumented tools or rigs, new techniques, and other elements of drilling technology. The government should make available these facilities for industry use and the incremental cost incurred by the test, would be partly or totally underwritten by the drilling industry. These test and evaluation experiments should be selected by an industry screening group.

To help implement this cooperative procedure for testing and evaluation the committee recommends that the government spend \$20 million to \$30 million on such testing equipment and programs over the next five years.

Downhole Drilling Motors

Further development of downhole drilling motors is needed, and while the industry is now engaged in such development, substantial government R&D support is needed to supplement industry efforts and assist in the testing of new motors.

The committee recommends that the government allocate \$5 million to \$10 million on downhole drilling motor development and demonstration over the next five years.

Drilling Mechanics

Better understanding of basic drilling mechanics is needed to increase instantaneous drilling rates and to lower drilling costs. Much of this work could be done within universities and private or nonprofit research organizations.

The committee recommends that the government spend \$2 million to \$4 million on drilling mechanics research over the next five years.

Application of New Materials

Much basic research has been performed by universities, government laboratories, industry, and private research laboratories to develop and characterize new drilling materials. Government assistance is needed in the application of these materials, particularly in hostile drilling environments where hydrogen sulfide gas and extreme heat can be encountered. Fatigue failure, abrasive wear, and seal materials are material-application problems which need to be supported by the government to the extent of providing industry with materials information.

The committee recommends that the government spend \$4 million to \$8 million on drilling materials research over the next five years.

Advanced Drilling Systems

Although the majority of drilling improvements are expected to be evolutionary, the government can help to accelerate the development of relatively promising advanced or novel drilling systems. Government support in this area should undergo frequent critical review, and drilling systems that do not continue to appear relatively promising would be dropped.

The committee recommends that the government spend \$5 million to \$10 million on advanced drilling systems over the next five years.

Technical Training

Government aid is needed for university programs, industry-attended schools, or industry in-house schools to train rig crew personnel and supervisors. This need arises because of the highly transient nature of many workers, which discourages employer-paid training programs. This situation is recognized by industry groups, such as the International Association of Drilling Contractors. The industry also needs more scientists and engineers.

The committee recommends that the government spend \$4 million to \$8 million on training programs over the next five years.

Deep-Water Technology

Although environmental problems pose the greatest and most urgent needs, drilling and production in deep water, particularly in the Arctic, present as yet unsolved economic and technical problems. R&D is needed to

measure loads on offshore structures in current use, to demonstrate some known concepts, and to determine the feasibility of others. Joint industry programs should support these efforts, except for government aid in forming the programs and in determining feasibility of advanced concepts.

The committee recommends that the government spend \$10 million to \$15 million on deep-water technology over the next five years.

Deep Permafrost Coring

Because no adequate engineering analysis can be made without a knowledge of the media involved, a deep permafrost coring research program is needed that includes sufficient core testing to characterize the ice-permafrost-soil system. This program should be supported by joint industry efforts, and only government "seed" money should be considered to aid the formation of the joint industry efforts.

The committee recommends that the government spend \$1 million to \$2 million to start research on the permafrost system over the next five years.

Arctic Environmental Problems

Arctic environmental data, mud disposal methods, acceptable spill handling, a gravel substitute, and cold weather materials are needed. Because of the varied disciplines involved and the general applicability to many companies, government aid could be helpful. R&D programs that include direct input from industry for program definition and guidance should be supported.

The committee recommends that the government spend \$1 million to \$2 million on Arctic environmental problems over the next five years.

Geothermal Equipment and Techniques

Geothermal energy development will require R&D efforts on high-temperature equipment and techniques which, because of uncertainties in the marketplace, industry will not undertake. Thus, government support is needed to develop high-temperature drill bits, drilling fluids, instrumentation, and other components. The programs should be aimed at immediately needed improvements to prove geothermal resources, because once the geothermal

market is established, industry will likely continue the needed R&D. Close interaction with industry is essential because of the latter's knowledge and experience in these programs.

The committee recommends that the government spend \$5 million to \$15 million on geothermal drilling R&D over the next five years.

Coal, Uranium, and Oil Shale Limitations and Opportunities

Ground control failures represent the greatest single hazard in coal mining (Carnegie-Mellon University, 1973). There is at present no reliable pumpable (epoxy resin) rock bolt placement system that will set the bolts without requiring the machine operator to go near unsupported ground. Automated rock bolt drilling and placement machines, with remote viewing and override controls for operator and mine safety, are needed. However, the costs of developing a reliable system of this type would probably be high.

The Bureau of Mines has estimated that perhaps as much as \$4 million per year is spent in programs on the problem of ground-control failures. Experimental drilling of small-diameter (1 in.) rock bolt holes is currently under way in an effort to improve the reliability and decrease the costs. A prototype of the pumpable rock bolt has been developed and is currently being tested in coal mines.

The Bureau of Mines is spending perhaps as much as \$2 million per year on developing efficient and economic hydraulic mining systems. Hydraulic mining machines have faster penetration rates, longer life, reduced power requirements, and reduced noise. Also, these machines can be combined with hydraulic transport equipment to create a more efficient total mining system.

In the near future, major changes in small-hole underground drilling will result from the use of hydraulically operated percussive drills now becoming operational. These tools will enable more rapid mine development by providing increased drilling power and rig mobility.

The use of guided horizontal and curved holes for exploration, methane gas and water drainage, and coal gasification is limited by inadequate control techniques and guidance systems that substantially increase hole costs. Thus, drillers need a telemetry system that will provide information on hole location and orientation as well as on rock properties. The Bureau of Mines is at present spending perhaps as much as \$1.5 million per year on control techniques and guidance systems for horizontal drilling.

The costs and technical problems of drilling big holes increase rapidly (sometimes almost geometrically) with hole diameter increases and hole deviations. Thus, the establishment of realistic minimum hole sizes and deviations for a variety of specific uses could increase footage drilled while saving money and time. Such standards can be developed from assessments made by big-hole contractors without creating new technology.

A major problem frequently encountered in big-hole drilling concerns the shutoff of formation water. For example, the flow of water in up-reaming can flood the mine below. Also, the loss of fluid circulation during blind-hole drilling can endanger the hole and the mine below.

At present, the hole liner must be designed to withstand the full hydrostatic pressure of the formation fluid. However, if the water zones could be sealed off from a pilot hole before drilling the big hole, and if the strength of the formation around the hole could be employed, lighter liners could be used, resulting in considerable savings. Up-reaming can be made more competitive by improved methods for water shutoff in drilling big holes, thereby also improving efficient access to the working face of the mine.

Since big-hole bits represent only about 3 percent of the total bit market, bit manufacturers have little incentive to invest in research and development. Current bits are adaptations of those developed for oil well drilling. Compared with oil well drilling practices, however, both the weight-on-bit and fluid-circulation rates are considerably lower in big-hole drilling. This causes powdered rock to adhere to the bit (called "bit balling"), thereby preventing the teeth from properly penetrating the rock. Improved bit design and drilling fluid systems specifically formulated to combat bit balling are needed.

Lightweight and mobile mechanized tunneling equipment for cutting holes of varying shapes and sizes in medium-hard and hard rock is not available at the present time. The mining industry has needed such equipment for many years.

A tunneling machine that combines the use of high-pressure water jets with conventional mechanical cutters is now being developed through combined government-industry efforts. A prototype has been built and tests are now being conducted (Robbins, 1975). This machine has the potential to significantly increase penetration rates.

Long-term efforts by both industry and the Bureau of Mines are aimed at automation of underground mining techniques. Such automated systems offer possibilities of increasing productivity and improving mine safety.

Recommendations for Coal, Uranium, and Oil Shale Drilling

Improvement of Existing Drilling Methods

Substantial cost savings and increased energy resources recovery would result from improved drilling methods, if they were widely used. These methods include:

- Improved big-hole drilling and raise boring.
- Small-hole drilling for roof control.
- Increased use of rotary-percussion drilling.
- Better horizontal drilling capability.

A combination of government and industry support is needed to commercialize these generally known concepts, with program definition and guidance from industry.

The committee recommends that the government spend \$15 million to \$30 million in this area over the next five years.

Drill Materials

Since some drilling applications are limited by materials capabilities, improved drill steels or other cutting materials are needed. Government aid is needed to develop materials information so that industry can make improvements.

The committee recommends that the government spend \$2 million to \$4 million on materials for mining bits and drills over the next five years.

Advanced Drilling Methods

Government support is generally needed to develop and commercialize innovative drilling equipment and techniques because the economic risks are too great for industry. Underground safety requirements add substantially to technical uncertainties, and market uncertainty is particularly great for drilling applications in oil shale and for uranium. The current level of effort on advanced drilling methods by the Bureau of Mines and the National Science Foundation/ Research Applied to National Needs Program (NSF/RANN) should be increased.

The committee recommends that the government spend \$10 million to \$20 million on advanced drilling methods over the next five years.

New Mining Methods

Several new mining concepts offer substantial cost reductions and increased energy resource recovery if they can be developed and commercialized. For example, water-jet cutting of coal has been proven technically feasible but must be made commercially practical before it will be widely used. Feasibility studies are needed on continuous-tunnel machine mining of oil shale and on water erosion drilling and extraction of uranium ore. Each of these techniques promises substantial improvements in productivity if commercialized.

The committee recommends that the government spend \$15 million to \$30 million on new mining methods over the next five years.

Total R&D recommendations are shown in Table 5.

Table 5. Total R&D Recommendations

	<u>Total Five-Year Budget (millions of dollars)</u>
<u>Oil, Gas, and Geothermal</u>	
1. Downhole Telemetry Systems	\$5-10
2. Testing and Evaluation	20-30
3. Downhole Drilling Motors	5-10
4. Basic Drilling Mechanics	2-4
5. Application of New Materials	4-8
6. Advanced Drilling Systems	5-10
7. Technical Training	4-8
8. Deep-Water Technology	10-15
9. Deep Permafrost Coring	1-2
10. Arctic Environmental Problems	1-2
11. Geothermal Equipment and Techniques	<u>5-15</u>
Subtotal	\$62-114
 <u>Coal, Uranium, and Oil Shale</u>	
1. Improvement of Existing Drilling Methods	\$15-30
2. Drill Materials	2-4
3. Advanced Drilling Methods	10-20
4. New Mining Methods	<u>15-30</u>
Subtotal	\$42-84

The total of these recommendations is expressed by the Committee as \$100 to \$200 million.

CHAPTER 4

IMPLEMENTATION

Drilling research, development, and production activities have been almost exclusively left to industry. Drilling for oil and gas is conducted as a service to the primary energy industry and any potential improvement or novel development in goods and services has to be directed to that customer. Over the years, close relationships have developed between drillers and their customers, and these relationships have helped to make cheap energy abundantly available in the United States. In the course of this study, the committee has identified at least four reasons for the government to participate more actively in the development and commercialization of technologies for drilling for energy resources.

1. The government has evolved new national goals regarding the development and production of energy sources.
2. The Congress has created ERDA and appropriated funds to several government agencies for the purpose of accelerating energy research and development efforts including commercialization.
3. Government participation can help to facilitate the transfer of technology throughout the energy industry.
4. Nontechnical regulations, controls, and procedures established by federal, state, and local governments usually affect drilling development and operations, such as health and safety requirements, conflict of interest laws, land rights, data rights, and environmental policies. A government agency interested in accelerating

a particular drilling activity can help to reconcile the policy objectives which led to these various rules and requirements and the objectives of the drilling technology program involved.

Government participation and the contribution which government can make should be shaped by a recognition that the federal government is neither a major user nor a major consumer of these technologies. Yet in making contributions to the development of technologies that will be employed by the private sector, the government must demonstrate that it is acting in the public interest and not engaging in a giveaway of the taxpayers' money. In areas such as defense and space, the government was the customer and it decided on the objectives, formulated the plans, directed the activities, paid the bills, and used the products. Protecting the public interest was more easily defined--to get the best product for achieving the established objective at the lowest dollar cost.

In energy research, if the federal government is to make a positive contribution to the national drilling effort, two sets of criteria must be met. One involves the requirement that the end product must have to be successful in the marketplace and the procedures to achieve the proper characteristics for such success; while the second involves the government's need for program review and approval, and accountability of tax dollars. Generally, sufficient flexibility in policies and practices exists to permit accommodation of the interests and requirements of both industry and government. Although either party can provide reasons why accommodation would not be acceptable, the nation needs a cooperative effort if the new energy goals are to be met. Sooner or later government and industry will have to work out arrangements that provide for successful efforts.

Drilling technologies are only one, albeit an important, component of larger systems of energy resource development. Indeed, much, if not most, drilling research is conducted as a component of energy research and development programs focused on these larger systems. With few exceptions, this is clearly the pattern characterizing the federal government's energy research programs; that is, government drilling R&D programs tend to be fragmented among and within agencies. The implementation strategy discussed in this section has been devised with this fragmentation in mind.

Not unexpectedly, the committee found that the main barriers to the more expeditious development and widespread utilization of new and improved drilling technologies which could contribute to the

discovery, definition, and development of the nation's energy resources are nontechnical. At the outset some members of the committee identified the primary problems as centering on government--government policies, the lack of adequate economic incentives, and antitrust and patent policies, for example. Further examination led to agreement that both the public and private sectors must and can work together to effectively promote and conduct coordinated RD&D programs and that such cooperative efforts are essential to meeting national energy goals.

The committee thus recommends an implementation strategy which stresses establishing and nurturing institutional arrangements for ensuring effective public-private coordination and cooperation in planning and conducting drilling research and development, as well as in implementing significant technological improvements which these efforts might produce.

Government's Energy Research, Development, and Demonstration Programs

The committee recognizes the inherent difficulties associated with any attempt to institutionalize effective communication and coordination among and within agencies of the federal government (or any large, complex organization for that matter), and is aware of the generally poor record of many past efforts undertaken with these goals in mind. Nevertheless, the committee recommends that an effort be made to provide more effective communication and coordination among those who plan, conduct, and oversee drilling RD&D programs.

Better communication and coordination would ensure that projects undertaken have good prospects of achieving results that will be accepted by the drilling industry. But the effort should not be limited to drilling; rather, the successful communication and coordination of programs for single systems components, such as drilling, likely depend upon the development of an overall system for coordinating all energy RD&D programs. Public Law 93-577 designates ERDA as the federal agency responsible for integrating and coordinating energy research, development, and demonstration. The committee believes that ERDA must take the initiative in formulating a communication and coordination plan for the federal government's energy RD&D programs.

Coordinated Public-Private Energy Research, Development, and Demonstration

Government energy RD&D programs should be planned with the aid of the specialized knowledge of experts from the drilling and energy industries. Moreover, the public and private sectors need to be well informed concerning their respective energy RD&D activities. While it is not altogether desirable to eliminate competitive or overlapping efforts, it is desirable to identify areas that are being overlooked, where joint funding might be required, and where additional public or private participation might facilitate the research or the deployment of a technology that has been or is being developed.

To insure the achievement of these goals, the committee recommends that an appropriate advisory committee structure be established. These advisory committees should include environmentalists, conservationists, and consumers, as well as energy experts. These committees would review the drilling R&D programs to insure they are complete, not excessively redundant, and to help the government assess the commercial value of projects.

Providing for Successful Commercialization

To improve the chances for successful commercialization, the committee suggests the following steps be taken prior to initiating research, hardware development, or test and evaluation activities.

1. Perform a market analysis particularly by individuals not associated with the proposed research and development which would reflect the views of those who are expected to buy the products. Specifically, this analysis should generate the range of characteristics required to assure commercial success of the proposed products or services.
2. Design the total program--from development to commercialization--to provide a product that possesses the characteristics derived from the market analysis. If this is not possible or the risk of success is judged too high, the program should not be initiated.
3. Identify and select performers who are recognized as among the best in that field of activity.
4. Negotiate arrangements and funding terms that give the program a good chance to succeed.

None of these steps are new to government agencies or the energy industry. They are generally recognized as necessary to success, yet too often they are not followed. Correction of this situation requires not only that the government formulate and direct such procedures, but it requires the use of people who realize the necessity of such measures and are motivated to implement them.

Test and Evaluation Facilities

Some potential technological advances are not pursued because of a lack of test and evaluation opportunities. The committee recommends that the government establish a program to provide adequate test and evaluation opportunities for both public and private energy RD&D programs. Since ERDA's laboratories possess considerable test facilities, these assets should be considered. A board should be established and made responsible for deciding when use of these test and evaluation facilities is in the national interest. Membership on the board should include both public and private experts, as well as representatives of public interest groups.

Facilitating Effective Communication

Presently, the communication within and between industry and government is not particularly effective. In an attempt to improve communication, and as a consequence of the successful workshop held as a part of this study, the committee, partly at the recommendation of workshop participants recommends that the National Academy of Sciences-National Academy of Engineering-National Research Council plan a program of symposia. This program, funded by industry and government, would be aimed primarily at the transfer of detailed information concerning the work, plans, and programs of both government and private institutions.

GLOSSARY OF TERMS

- annular space: The space surrounding a cylindrical object within a cylinder. The space around a pipe suspended in a wellbore is often termed the annulus, and its outer wall may be either the wall of the borehole or the casing.
- annulus: See annular space.
- blowout preventer: Equipment installed at the wellhead for the purpose of controlling pressures in the annular space between the casing and drill pipe, or in an open hole during drilling and completion operations.
- BOP: See blowout preventer.
- Christmas Tree: The assembly of valves, pipes, and fittings, usually high pressure, used to control the flow of oil and gas from the casing head.
- directional drilling: To drill at an angle from the vertical. Controlled directional drilling makes it possible to reach subsurface points laterally remote from the point where the bit enters the earth.
- dogleg: A term applied to a sharp change of direction in the wellbore.
- elastomer: Any of the various elastic substances resembling rubber.
- fire-flooding: A process of burning part of the oil in place to raise the temperature of the remaining oil for production purposes.
- fish: Any object accidentally left in the wellbore during drilling or workover operations.
- fishing: An operation to recover from a wellbore any equipment accidentally left there during drilling operations. Also, an operation to remove from an older well certain items of equipment so that the well may be reconditioned.
- hard-wire telemetry: The use of sampling/measurement devices connected by a "hard-wire" (cable as versus radio channel) to readout instrumentation on the surface.
- instantaneous drilling rate: The rate at which the drill is penetrating the formation.

kelly: The heavy square or hexagonal steel pipe which is suspended from the swivel through the rotary table and connected to the upper end of the drill pipe to turn the drill string. The kelly transmits torque from the rotary table to the drill string and permits a free vertical movement for making the hole.

mud: The thixotropic liquid that is circulated through the wellbore during rotary drilling and workover operations.

overburden: A layer of material, usually earth, that lies above a strata to be mined.

packed hole: Oversized portions of drill collar that almost fill the borehole.

rubble chimney: Fractured particles of oil shale that form an underground "chimney" for in situ retorting.

sidetracking: Directional drilling past a fish that cannot be efficiently or economically recovered from the hole and has usually been covered with cement.

slurry: A plastic mixture of portland cement and water that is pumped into the well to harden, after which it supports the casing and provides a seal in the wellbore to prevent migration of underground fluids.

stope: A steplike underground excavation for the removal of ore that is formed as the ore is mined in successive layers.

sub: Short, threaded pieces used to connect parts of the drill string which cannot otherwise be screwed together because of differences in thread size or design.

thixotropic: The property of various gels of becoming fluid when shaken.

twist-off: To twist a joint of drill pipe in two by excessive force applied by the rotary table.

weight-on-bit: The difference between the total weight of the drill string and the suspended weight.

whipstock: A long steel casting using an inclined plane to cause the bit to deflect from the original borehole at a slight angle. Whipstocks are used in controlled directional drilling for straightening crooked boreholes and for sidetracking to avoid unretrieved fish.

W.O.C.: Waiting on cement. A term used in drilling reports referring to that time during which drilling or completion operations are suspended to enable the cement in a well to sufficiently set-up or harden.

REFERENCES

- Bartlett, L., Drilling Operations in the Arctic. National Research Council, 1975. Background Papers for a Drilling Technology Workshop, Ad Hoc Committee on Technology of Drilling for Energy Resources, Energy Engineering Board, Assembly of Engineering, Washington, D.C.: National Academy of Sciences, pp. 36-49.
- Blenkarn, K.A., Drilling Operations for Offshore Oil and Gas Wells. National Research Council, 1975. Background Papers for a Drilling Technology Workshop, Ad Hoc Committee on Technology of Drilling for Energy Resources, Energy Engineering Board, Assembly of Engineering, Washington, D.C.: National Academy of Sciences, pp. 55-75.
- Brantly, J.E., 1971. History of Oil Well Drilling. Gulf Publishing Co., Houston, Texas.
- Carnegie-Mellon University Workshop on Advanced Coal Technology, 1973. A Program of Research, Development, and Demonstration for Enhancing Coal Utilization to Meet National Energy Needs. Carnegie-Mellon University, Pittsburgh, Penn. October.
- Dowding, C.H., Horizontal Drilling Potential. National Research Council, 1975. Background Papers for a Drilling Technology Workshop, Ad Hoc Committee on Technology of Drilling for Energy Resources, Energy Engineering Board, Assembly of Engineering, Washington, D.C.: National Academy of Sciences, pp. 352-376.
- Garrison, E.P., Directional Drilling and Downhole Motors. National Research Council, 1975. Background Papers for a Drilling Technology Workshop, Ad Hoc Committee on Technology of Drilling for Energy Resources, Energy Engineering Board, Assembly of Engineering, Washington, D.C.: National Academy of Sciences, pp. 304-325.
- Geer, R.L., National Needs, Current Capabilities, and Engineering Research Requirements. Offshore Petroleum Industry. National Research Council, 1975. Background Papers on Seafloor Engineering, Volume I, Committee on Seafloor Engineering, Marine Board, Assembly of Engineering, Washington, D.C.: National Academy of Sciences, p. 1-74.

- Hammett, D.S., National Research Council, 1975. Background Papers for a Drilling Technology Workshop, Ad Hoc Committee on Technology of Drilling for Energy Resources, Energy Engineering Board, Assembly of Engineering, Washington, D.C.: National Academy of Sciences, p. 128.
- Harding, C., Long Horizontal Drilling in Rock and Gouge Materials. National Research Council, 1975. Background Papers for a Drilling Technology Workshop, Ad Hoc Committee on Technology of Drilling for Energy Resources, Energy Engineering Board, Assembly of Engineering, Washington, D.C.: National Academy of Sciences, pp. 377-398.
- Heilhecker, J., Telemetry and Drill-Stem Problems. National Research Council, 1975. Background Papers for a Drilling Technology Workshop, Ad Hoc Committee on Technology of Drilling for Energy Resources, Energy Engineering Board, Assembly of Engineering, Washington, D.C.: National Academy of Sciences, pp. 279-291.
- Hughes Tool Company, 1975. Rig Report for October 1975.
- Hustrulid, W., Drilling Small-Diameter Holes. National Research Council, 1975. Background Papers for a Drilling Technology Workshop, Ad Hoc Committee on Technology of Drilling for Energy Resources, Energy Engineering Board, Assembly of Engineering, Washington, D.C.: National Academy of Sciences, pp. 81-126.
- Jenner, J.W., 1973. Modern Petroleum Technology, Chap. 4. Eds. G.D. Hobson and W. Pohl. Applied Science Publishers, Ltd., Essex, England.
- Jet Propulsion Laboratory Report, 1975. Status Report, Geothermal Program Definition Project Part II: Geothermal Energy Development Status. Jet Propulsion Laboratory, Pasadena, Calif., April 4.
- Joint Association Survey of the U.S. Oil and Gas Producing Industry - 1973, 1975. API, IPAA, and Mid-Continent Oil and Gas Association, Washington, D.C.
- Maurer, W.C., 1968. Novel Drilling Techniques. Pergamon Press, London.
- McDonald, W.J., and C.E. Ward, 1975. Borehole Telemetry System is Key to Continuous Down-Hole Drilling Measurements. Oil and Gas Journal, Sept. 15, 1975. p. 111.

- McGahan, W., and J.W. Adams, Blast-Hole Drilling. National Research Council, 1975. Background Papers for a Drilling Technology Workshop, Ad Hoc Committee on Technology of Drilling for Energy Resources, Energy Engineering Board, Assembly of Engineering, Washington, D.C.: National Academy of Sciences, pp. 171-204.
- National Research Council, 1975. Background Papers for a Drilling Technology Workshop, Ad Hoc Committee on Technology of Drilling for Energy Resources, Assembly of Engineering, Washington, D.C.: National Academy of Sciences.
- Petroleum Engineer International, 1975. Deep Sea Drilling Project Continued, p. 17. September.
- Petroleum Engineer International, 1975. International Offshore Rig Register, p. 19. October.
- Petroleum Extension Service, University of Texas at Austin, 1970. Third Edition. Primer of Oilwell Drilling. University of Texas at Austin.
- Petroleum Extension Service, University of Texas at Austin, 1968. Lessons in Rotary Drilling - Making Hole. University of Texas at Austin.
- Reed Mining News, January 1976. Teton Drilling World's Longest 12-Foot Shaft. p. 1.
- Robbins, R., Big-Hole Drilling, Raise-Boring and Tunneling. National Research Council, 1975. Background Papers for a Drilling Technology Workshop, Ad Hoc Committee on Technology of Drilling for Energy Resources, Energy Engineering Board, Assembly of Engineering, Washington, D.C.: National Academy of Sciences, pp. 218-247.

A SELECTED BIBLIOGRAPHY

- Bechtel Corporation, 1975. Research Program Plan for Meeting Tomorrow's Needs in Tunneling and Excavation. Report prepared for the National Science Foundation (RANN). Bechtel Corporation, San Francisco, Calif., February.
- Bradley, W.B., 1973. Deviation Forces from the Penetration Failure of Anisotropic Rock. ASME Paper No. 73 — Pet-8. Presented at ASME Petroleum Division Conference at Los Angeles, Calif., Sept. 16-20.
- Gatlin, Carl, 1960. Petroleum Engineering: Drilling and Well Completions, Prentice-Hall, Inc., Englewood Cliffs, N.J.
- Gravley, W., Drilling Mechanics of On-Shore Wells. National Research Council, 1975. Background Papers for a Drilling Technology Workshop, Ad Hoc Committee on Technology of Drilling for Energy Resources, Energy Engineering Board, Assembly of Engineering, Washington, D.C.: National Academy of Sciences, pp. 5-28.
- Lubinski, A., and H.S. Woods, 1953. Factors Affecting the Angle of Inclination and Dog-Legging in Rotary Bore Holes. API Drilling and Production Practices. p. 222.
- Maurer, W.C., Novel Drilling Concepts. National Research Council, 1975. Background Papers for a Drilling Technology Workshop, Ad Hoc Committee on Technology of Drilling for Energy Resources, Energy Engineering Board, Assembly of Engineering, Washington, D.C.: National Academy of Sciences, pp. 330-346.
- Rowley, D., Vertical and Horizontal Coring and Sampling. National Research Council, 1975. Background Papers for a Drilling Technology Workshop, Ad Hoc Committee on Technology of Drilling for Energy Resources, Energy Engineering Board, Assembly of Engineering, Washington, D.C.: National Academy of Sciences, pp. 134-165.

Simpson, J., Drilling Fluids and Environments. National Research Council, 1975. Background Papers for a Drilling Technology Workshop, Ad Hoc Committee on Technology of Drilling for Energy Resources, Energy Engineering Board, Assembly of Engineering, Washington, D.C.: National Academy of Sciences, pp. 254-275.

Tidwell, D.R., and W.T. Ilfrey, 1970. Drilling Risers. Mechanical Engineering, March, 1970. p. 21.

Woods, H.B., and Arthur Lubinski, 1955. Use of Stabilizers in Controlling Hole Deviation. API Drilling and Production Practices. p. 165.

